



## **NRC Reactor Concepts (R-100)**

Welcome to the Nuclear Regulatory Commission's Reactor Concepts (R-100) web-based training. This course is open to all NRC personnel and provides a baseline of knowledge of what NRC does in relation to nuclear power plants and how it maintains the protection of people and the environment.

The mission of NRC is to license and regulate the Nation's civilian use of byproduct, source, and special nuclear materials in order to protect public health and safety, promote the common defense and security, and protect the environment. After completing the course, you will be able to speak knowledgeably and with confidence to the general public in relation to the mission of NRC.

[Begin Course](#)

[Videos](#)

[Acronyms](#)

[Glossary](#)

[Resources](#)

[Training Page](#)

# Nuclear Power for Electrical Generation

## Chapter Introduction

[Go To Top](#)

## Chapter Overview

The purpose of a [nuclear power plant](#) is to generate electricity from steam created by nuclear heat. It should not be surprising, then, that a nuclear power plant has many similarities to other electrical generating facilities using steam. Conversely, nuclear power plants have some significant differences from other plants.

Throughout this chapter, we will examine: how to generate electricity using steam energy, the most common ways for producing commercial electricity in the United States (U.S.), and the significant ways that nuclear power plants differ from other power plants. We will also explore the differences and similarities between the two types of commercial nuclear plants in the U.S.



## Objectives

After completing this chapter, you will be able to:

- Describe the role of nuclear power in generating commercial electrical power in the U.S.
- Describe the process for generating electrical power using steam.
- Identify the most common sources and costs of commercial electrical power generation in the U.S.
- Identify characteristics unique to nuclear power generation.
- List the barriers to the escape of fission products from the fuel.
- Identify the types of nuclear power plants used for commercial electrical power generation in the U.S.

**Estimated time to complete this chapter:**

35 minutes

## Basic Electrical Generation Using Steam



### Commercial Generation of Electricity

Commercial generation of electricity requires large-scale production of electricity in an economical and cost-effective manner. As both a primary consumer and producer of electricity, the U.S. has multiple options and methods for producing electricity. By far, the most prevalent is a steam electric power plant.

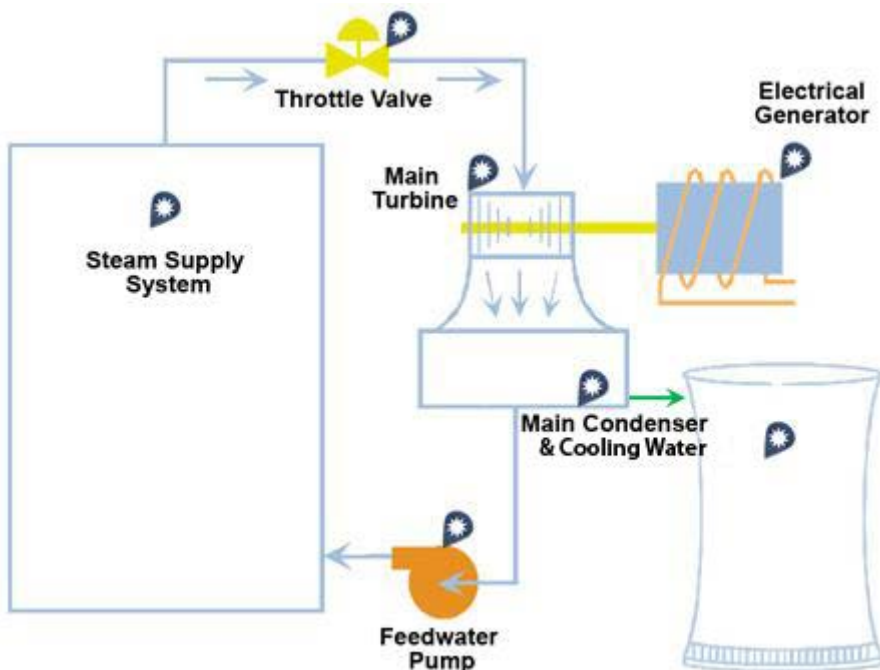

The steam supply system includes the boiler. The boiler provides the heat that produces the steam. All steam electric power plants have a boiler, regardless of the nature of the fuel used to generate the steam.

The main turbine provides the force used to turn the rotor of the electrical generator. The turbine includes a rotary engine made with a series of curved vanes on a rotating shaft. Turbines are considered the most economical means to turn large electrical generators.

The electrical generator is an electromagnetic device that converts mechanical (rotational) energy into electrical energy. The electrical generator includes the rotor and the stator.

The main condenser is a large heat exchanger designed to cool exhaust steam from a turbine to below the boiling point so that it can be returned to the heat source as water. The heat removed from the steam by the condenser is transferred to a circulating (cooling) water system and is exhausted to the environment, either through a cooling tower or directly into a body of water.

The position of the throttle valve allows the operators to control the amount and rate of steam going to the turbines. The position of the throttle valve is directly related to the amount of electricity a plant produces at any given time.

The feedwater pump guarantees that cool water continuously enters the boiler. Most of the water comes from the condenser, while additional water may be added from an outside source.

## Components of a Steam Power Plant

First, let's consider the basics of a **steam** power plant. All steam power plants, regardless of fuel type, have the same basic functionality and use many of the same components.

Select the components of a basic steam power plant for an explanation of its function or role.

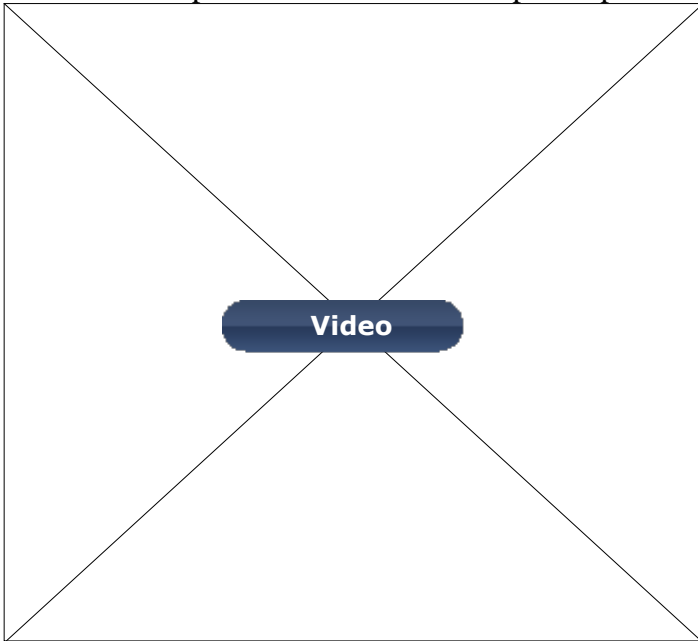

## Electrical Generator

Steam electric power plants can use a number of fuels to create the steam, but all require an [electrical generator](#) to produce the electricity. In most large-scale electrical generators, a magnet (rotor) revolves inside a stationary

coil of wire (stator). The magnetic lines of flux ‘cut,’ or flow, through the stator and create a flow of electrons inside the wire. This flow of electrons is electricity.

Some mechanical device (wind turbine, water turbine, steam turbine, diesel engine, etc.) must be available to provide the force for turning the rotor.

Select Play to view an electrical generator creating electricity. (View [transcript](#).)

Show me a [rotor](#) and [stator](#) used in commercial power plants.

The rotor (magnet) is centered in the coiled wires of the stator. An outside force spins the magnet within the stator, creating a magnetic field, which in turn generates an electric current.

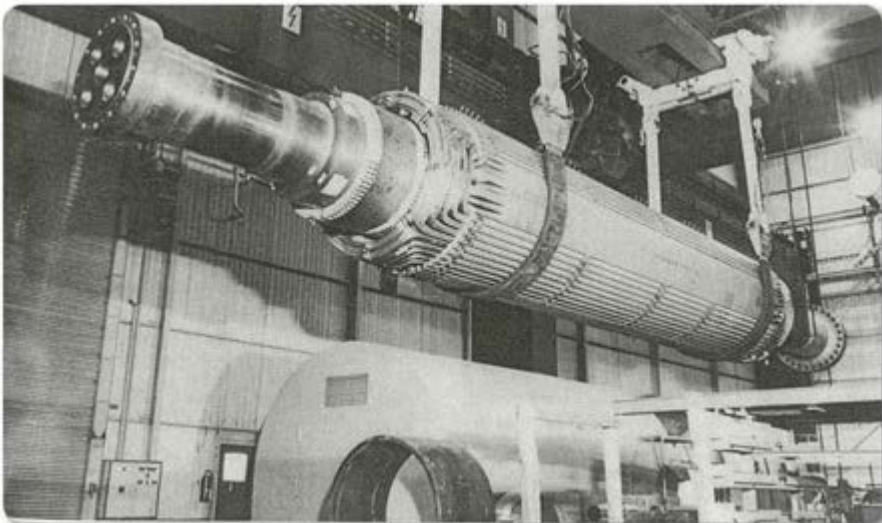
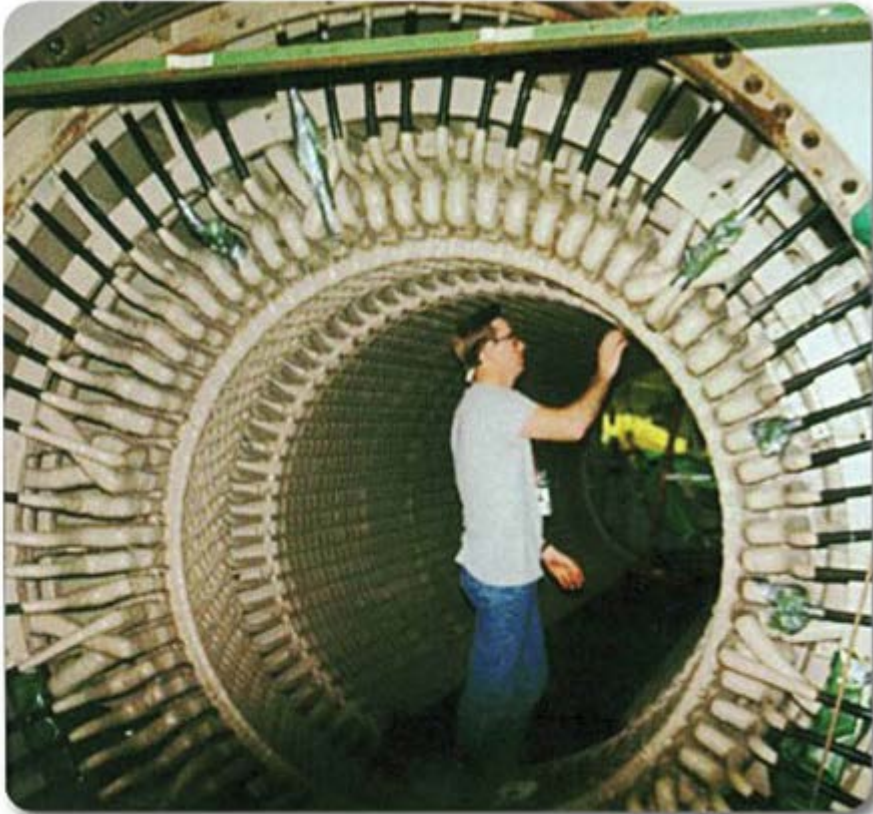

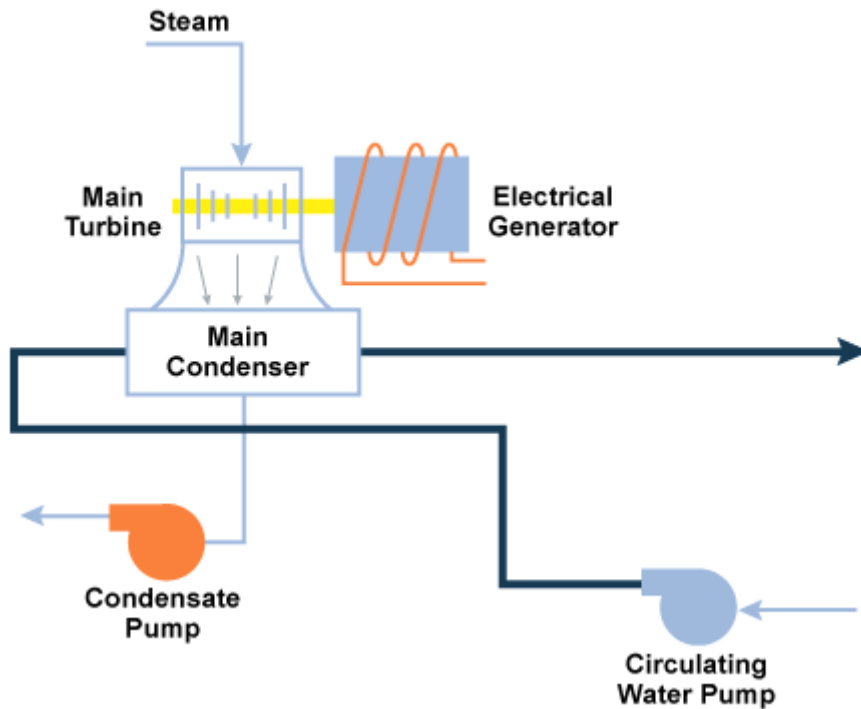

## Cooling with Circulating Water

To operate properly, steam plants need a circulating water system to remove excess heat from the steam system. The steam exiting the turbines enters the condenser and its heat is transferred to the environment.

The circulating water system pumps water through thousands of metal tubes in the plant's condensers. Steam exiting a plant's turbine is cooled and condensed back into water as it comes into contact with the much-cooler tubes. Since the tubes provide a barrier between the steam and the environment, there is no physical contact between a plant's steam and the cooling water.

The condenser is maintained at a vacuum since that will increase the amount of energy that the turbine can extract from the steam. Because a condenser operates at a vacuum, any tube leakage in this system will produce an inflow of water into the condenser rather than an outflow of water to the environment.

There are three [methods for cooling with circulating water](#).

Select a tab for an explanation of each method.

[Body of Water](#)[Forced Draft Tower](#)[Natural Convection Tower](#)

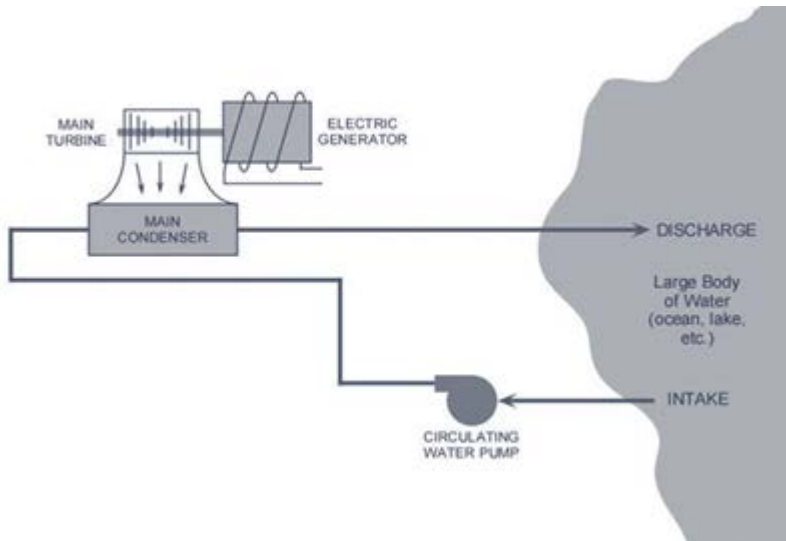

Power plants located on large bodies of water often discharge their circulating water directly back to the ocean or other body of water under strict environmental protection regulations. The discharge water temperature and chemical composition is regulated by the states. The expected temperature increase from circulating water inlet to outlet is about 5 to 10 degrees Fahrenheit.

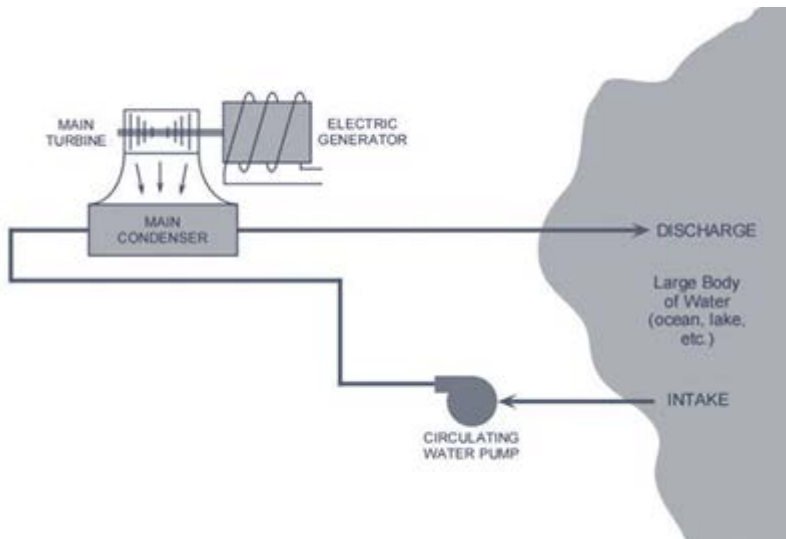

Power plants located on large bodies of water often discharge their circulating water directly back to the source under strict environmental protection regulations. The discharge water temperature and chemical composition are regulated by the states. The expected temperature increase from circulating water inlet to outlet is about 5 to 10 degrees Fahrenheit.

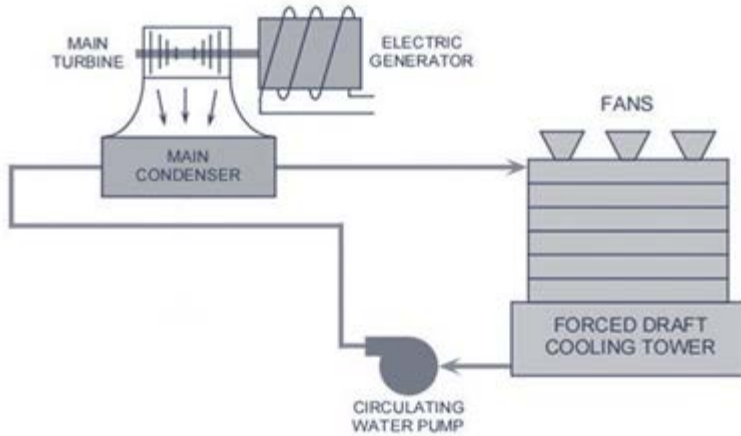

With a forced draft cooling tower, the circulating water is pumped into the top of the tower after passing through the condenser and allowed to splash downward transferring some of its heat to the air. Several large electrical fans, located at the top of the cooling tower, provide forced air circulation for more efficient cooling.

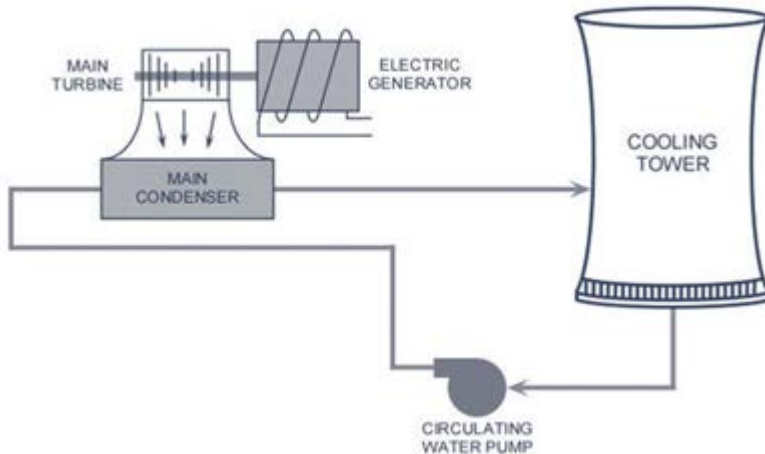

The tall, hourglass-shaped, natural convection cooling towers do not require fans to transfer the excess heat from the circulating water system into the air. Rather, the natural tendency of hot air to rise removes the excess heat as the circulating water splashes down inside the cooling tower. These towers are typically several hundred feet tall. The "steam" vented from the top of a cooling tower is really lukewarm water vapor.

As the warm, wet air from inside the cooling tower contacts the cooler, dryer air above the cooling tower, the water vapor that cannot be held by the cooler air forms a visible cloud. This is because the colder the air is, the lower its ability to hold water. The released cloud of vapor will only be visible until it is dispersed and absorbed by the air. However, that released water vapor represents a significant 'loss' of volume from the circulating water system. Plants need to make up tens of thousands of gallons of water per hour to accommodate these losses.





## Check Your Knowledge

- **Which items describe using steam to generate electrical power?**

Select all that apply, then select Done.

1. correct: Steam power is the most widely used method of large-scale power generation.
  2. Steam power plants are very limited in the types of fuel that can be used to create the steam.
  3. correct: Basic components of steam power plants include the steam supply system, the cooling system, the turbine and throttle valve, the electrical generator, and the feedwater pump.
  4. The water used to create the steam and the water used for cooling mix freely in the cooling system.
  5. Only nuclear power plants have environmental regulations regarding their cooling system.
- Correct. Steam power is the most efficient means of large-scale power generation and can use a variety of fuels to create the steam. Regardless of the fuel used, the basic components of steam power plants include the steam supply system, the cooling system, the electrical generator, the throttle valve, and the feedwater. All steam electric plants keep the boiler water and the cooling water isolated from each other in order to conform with strict environmental regulations.
  - Incorrect. Steam power is the most efficient means of large-scale power generation and can use a variety of fuels to create the steam. Regardless of the fuel used, the basic components of steam power plants include the steam supply system, the cooling system, the electrical generator, the throttle valve, and the feedwater. All steam electric plants keep the boiler water and the cooling water isolated from each other in order to conform with strict environmental regulations.

## Types of Power Plants



### Types of Power Plants Used for Large-Scale Power Production in the U.S.

Recall that most of the electrical power in the U.S. is created from steam electric power plants. There are numerous types of steam electric plants, including:

- Coal
- Oil
- Natural gas
- Petroleum
- Nuclear

In addition, a number of alternative sources are being explored for large-scale adoption. At this time, however, hydroelectric is the only non-steam based method that is comparatively cost effective.

Let's take a look at the various types of power production facilities in the U.S. We'll start with hydroelectric.

## Hydroelectric Power Plants

In a hydroelectric power plant, water flows from a higher level to a lower level. The natural, downward flow of the water turns the blades of a water turbine, which causes the rotor of the attached electrical generator to spin and produce electricity. Hydroelectric power has a production cost of approximately \$0.0085 per kilowatt hour (kwh) (current data through 2009). Basically, once the cost of building the plant is expended, the cost of producing the electricity is incredibly small.

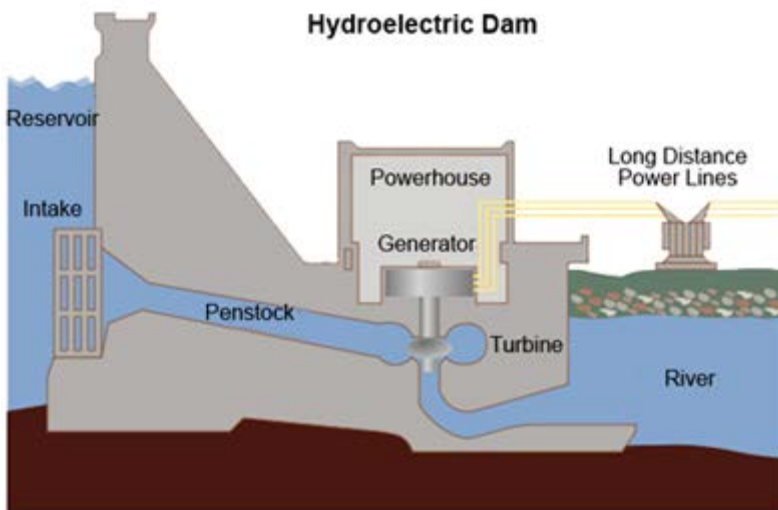

## Fossil Fuel Power Plants

Fossil fuel power plants are steam electric power plants. A fossil-fueled power plant burns coal, natural gas, or oil to supply the necessary steam. The **approximate** cost per kwh for coal is \$0.03; oil is \$0.12, and gas is \$0.05. These costs are highly variable due to the volatility of the fuel cost. (data through 2009).

Electric costs can be misleading based on various government subsidies that exist.

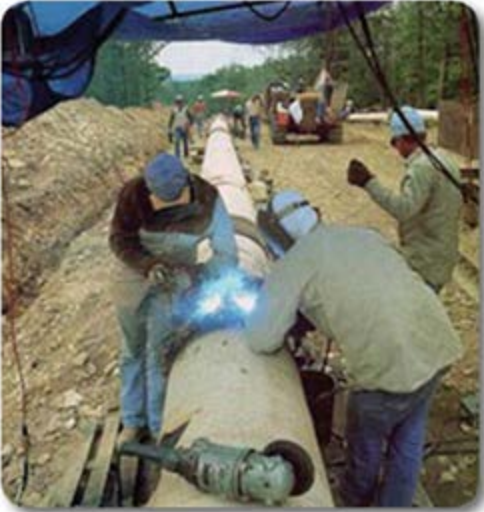



## Nuclear Power Plants

In a nuclear power plant, many of the components are similar to those in a fossil-fueled plant, except that the steam boiler is replaced by a [Nuclear Steam Supply System](#) (NSSS). The NSSS consists of a nuclear reactor and all of the components necessary in supporting the reactor's production of high-pressure steam, which will be used to turn the turbine for the electrical generator. The nuclear core is simply a heat source harnessed to boil water for spinning a steam turbine.

The cost per kwh hour for electricity generated through a nuclear power plant is approximately \$0.02 (data through 2009). Nuclear plants generally have very high capital costs to build, but relatively low fuel costs.

## Alternative Sources

With the increase in environmental concerns, the volatility in the cost of fossil fuels, and concerns regarding dependence on foreign fuel sources, interest is growing in alternative sources for large-scale electrical power generation. The most common and popular include solar and wind farms, at this time, with research into bio-fuels as an alternative for fossil fuel steam plants in its infancy. However, the comparative costs per kwh for solar and wind farms are not competitive with fossil fuels. Solar power costs per kwh are approximately \$0.50, while power from wind farms costs approximately \$0.05 to \$0.08 per kwh (2009 data). The chief concern with these alternative sources is bringing cost down while increasing capacity (how much electricity is generated).

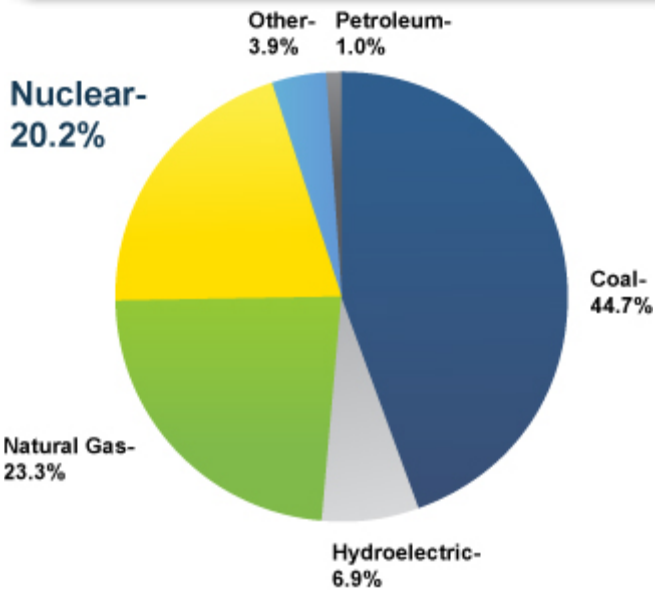

### Net Generation by Source

Commercial nuclear power plants generate approximately 20% of the electricity produced in the U.S. The total generation is approximately 4,200 thousand gigawatt-hours.

For comparison purposes, nuclear generation accounts for the following of the total electrical production in some other countries: 75% in France, 46% in Sweden, 43% in Ukraine, 39% in South Korea, 30% in Germany, and 30% in Japan.

The electricity produced in the U.S. from nuclear power is equivalent to 31% of the world's total nuclear-generated electrical power. This compares with 16% for France, 13% for Japan, 7% for Germany, 5% for Russia, and 4% for South Korea and the United Kingdom.

So, even though only 20% of our power comes from nuclear power, that number represents the largest portion of the global total of power generation by commercial nuclear plants.



## Check Your Knowledge

- **What are the most common types of power plants used for large-scale power production in the U.S.?**

Select all that apply, then select Done.

1. Solar farms
  2. correct:Hydroelectric
  3. correct:Nuclear power
  4. correct:Fossil fuel steam power plant
  5. Bio-fuels
- Correct. The most common types of large-scale power production in the U.S. are hydroelectric power plants and nuclear and fossil fuel steam power plants. Although alternative sources such as solar and wind farms and bio-fuel steam plants are gathering more interest, they are not large-scale contributors.
  - Incorrect. The most common types of large-scale power production in the U.S. are hydroelectric power plants and nuclear and fossil fuel steam power plants. Although alternative sources such as solar and wind farms and bio-fuel steam plants are gathering more interest, they are not large-scale contributors.

## Characteristics Unique to Nuclear Power Generation

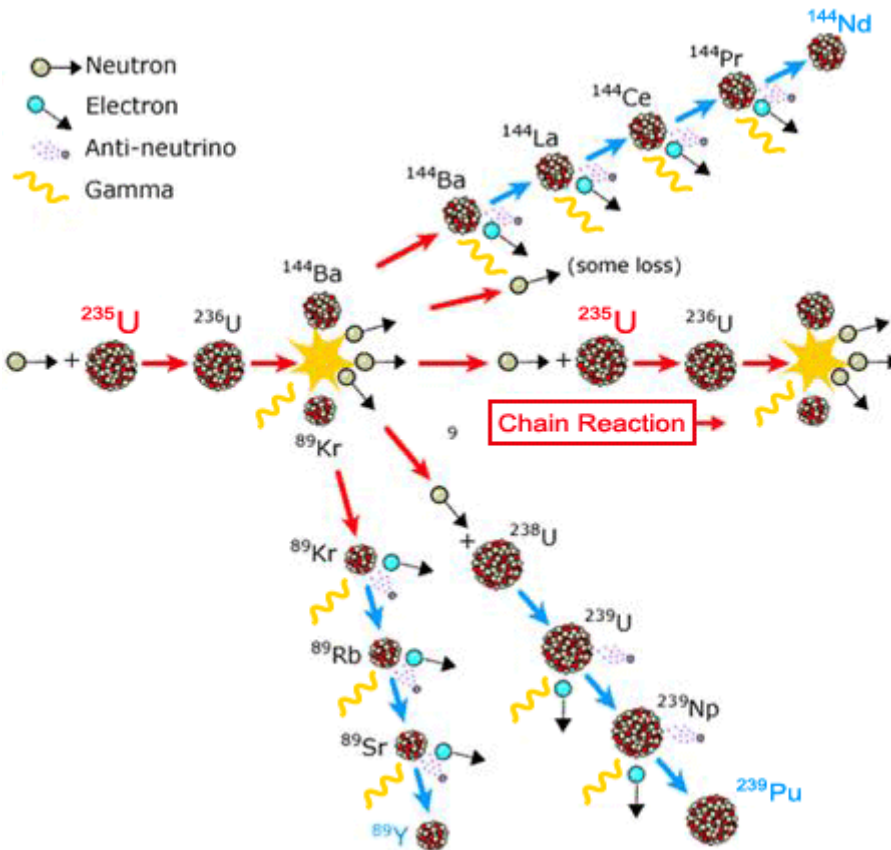

## Chain Reaction Creates Heat to Create Steam

Like a fossil-fueled plant, a nuclear power plant is a steam power plant and boils water to produce electricity. Unlike a fossil-fueled plant, a nuclear plant's energy does not come from the burning of fuel but from the fissioning (splitting) of fuel atoms. The bulk of the energy is from the kinetic energy (motion) of the fission products released from the uranium [nucleus](#) after it splits.

In short, every time an atom splits in the core, it releases heat energy. That heat energy is used to generate the steam. By creating a [chain reaction](#) in the reactor core, heat energy is consistent and constant. As a result, the steam generation—and by extension the generation of electricity—is predictable and controllable.

Chapter 2: Fission Process & Heat Production looks at fission and heat in more detail.

## Nuclear Fuel

The most common fuel for the production of electricity by reactor plants in the U.S. is [Uranium](#). The level of enrichment (concentration of U-235) in U.S. power reactors is significantly lower than in Naval reactors and nuclear weapons. Commercial U.S. nuclear power reactors will **not** explode like a nuclear bomb.

Move the tab along the slider bar for information about the processing of uranium into nuclear fuel.

For non-sighted users, please use these skip links to access the items on the slider.

- [Uranium-235 and Uranium-238](#)
- [Uranium Processing](#)

- [Fuel Pellets](#)



## Uranium-235 and Uranium-238

The uranium starts out as ore and contains a very low percentage (or low enrichment) of the desired atoms (U-235), approximately 0.7% by weight. The U-235 is a more desirable atom for fuel, because it is easier to cause the U-235 atoms to fission (split) than the much more abundant U-238 atoms.



## Uranium Processing

After mining, the uranium ore goes to a mill that chemically and mechanically increases the percentage of U-235 from 0.7 percent to anywhere from 3.5% to 5%, depending on the design of the fuel. This process is known as enrichment.

During the process, the U-235 is extracted and recovered in a concentrated form. This concentrate is called yellowcake and contains about 80% of U-238.





## Fuel Pellets

Once the uranium is enriched, it is further processed into fuel pellets. The fuel pellets are then heated to very high temperatures to achieve ceramic properties. All fuel pellets are consistent in size and shape. The consistency allows for greater control over a reactor's processes.

Finally, the fuel pellets are inspected to guarantee their consistency in size, shape, and enrichment.

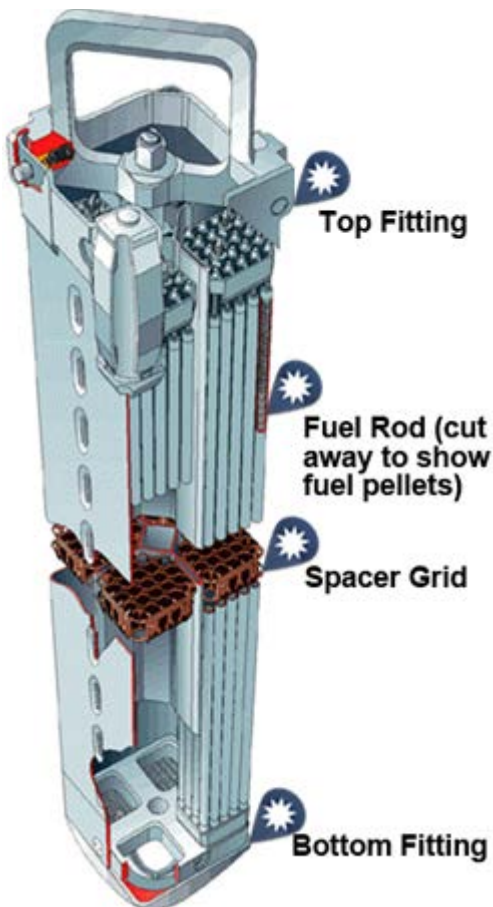

The upper and lower end fittings serve as the upper and lower structural elements of the assemblies. The lower fitting (or bottom nozzle) directs the coolant flow to the assembly through several small holes machined into the fitting. There are also holes drilled in the upper fitting to allow the coolant flow to exit the fuel assembly. The

upper end fitting also has a connecting point to which the refueling equipment attaches for moving the fuel assembly with a crane.

The upper and lower end fittings serve as the upper and lower structural elements of the assemblies. The lower fitting (or bottom nozzle) directs the coolant flow to the assembly through several small holes machined into the fitting. There are also holes drilled in the upper fitting to allow the coolant flow to exit the fuel assembly. The upper end fitting also has a connecting point to which the refueling equipment attaches for moving the fuel assembly with a crane.

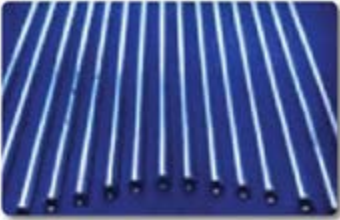

The fuel rods contain the ceramic fuel pellets. The fuel rods are approximately 12 feet long and contain a space at the top for the collection of any gases that are produced by the fission process. These rods are arranged in a square matrix ranging from 17 x 17 for pressurized water reactors to 10 x 10 for boiling water reactors.



The spacer grids separate the individual rods with pieces of metal. This provides rigidity to the assemblies and allows coolant to flow freely through the assemblies and around the fuel rods.

## Reactor Fuel Assemblies and Control Rods

Commercial reactor fuel assemblies consist of the same major components. These major components are the fuel rods, the spacer grids, and the upper and lower end fittings.

In all cases, the reactor coolant (water) flows through the reactor fuel assemblies, on the outside of the fuel rods, from bottom to top. As the coolant removes the heat from the fuel, it grows progressively hotter from the bottom to the top of the core.

All reactors also have control rods. Control rods are used to control the chain reactions inside the reactor by absorbing neutrons that normally are absorbed in the fuel to produce fission.

A pressurized water reactor (PWR) incorporates control rod tubes in the fuel assemblies, while a boiling water reactor (BWR) intersperses the controls rods between the fuel assemblies.

Select the component of the fuel assembly for an explanation of its function or role.



## Check Your Knowledge

- **Which of the following items are unique characteristics to nuclear power plants?**  
Select all that apply, then select Done.
  1. Steam generation
  2. correct:Nuclear chain reaction
  3. correct:Uranium-235
  4. correct:Ceramic fuel pellets
  5. correct:Fuel assemblies
- Correct. All of these items are unique to nuclear plants except for steam generation. Nuclear power plants are similar to fossil-fuel plants in that they both use steam to generate electricity.
- Incorrect. All of these items are unique to nuclear plants except for steam generation. Nuclear power plants are similar to fossil-fuel plants in that they both use steam to generate electricity.

## Barriers to Prevent the Escape of Fission Products

Earlier, we mentioned that the fission processes were a unique characteristic of nuclear reactors. One concern with the fission process is the potential for fission products, which are radioactive, to escape outside of the fuel assemblies and reactor, and into the environment. To prevent this, there are three barriers to fission product escape. The three barriers that fission products would encounter are:

1. Fuel Rod Cladding - [Cladding](#) refers to the zirconium alloy (stainless steel) tubes that house the fuel pellets. The zirconium cladding retains most of the fission products. The cladding helps contain the fuel and fission products within the fuel assembly.
2. [Reactor Coolant System](#) (RCS) - The RCS includes the reactor vessel and attached piping that contains the coolant, usually water, which flows through the core. The coolant transfers the core's fuel heat to the feedwater to produce steam for the turbine. If fission products escape through the fuel rod cladding, they are generally contained within the RCS.
3. [Containment](#) Building - The containment building is the final barrier to the escape of fission products. Containment buildings are designed to prevent the escape of fission products to the environment and general public, should both the fuel rod cladding and the RCS fail.



## Check Your Knowledge

**In what order would escaping fission products encounter the barriers?**

Enter numbers (1 for first through 3 for last) in the correct order, then select Done.

- Containment
- Cladding
- Reactor Coolant System (RCS)

## Types of Nuclear Power Plants



### Two Types of Commercial Nuclear Power Plants in the U.S.

There are two basic types of reactor plants being used in the U.S. to commercially produce electricity: the [boiling water reactor](#) (BWR) and the [pressurized water reactor](#) (PWR).

Both BWR and PWR plants in the U.S. are designed for optimal safety. In other words, they will tend to shut themselves down in accident conditions. As such, regardless of the type, all commercial U.S. reactors require human intervention to keep the reactor **running**.

In the event of various abnormal occurrences, the reactor is designed to be automatically shut down. Nuclear plants are also designed with three barriers that prevent fission products from escaping to the environment, thus limiting potential risk to the surrounding environment and general public.

Most nuclear power plants around the world follow the same basic design as the plants in the U.S. but there are some significant differences, particularly in the former Soviet Union. Chapter 12: The Chernobyl Accident discusses some of those differences.

Let's take a look at the basic similarities and differences between a BWR and PWR. We'll start with the BWR.

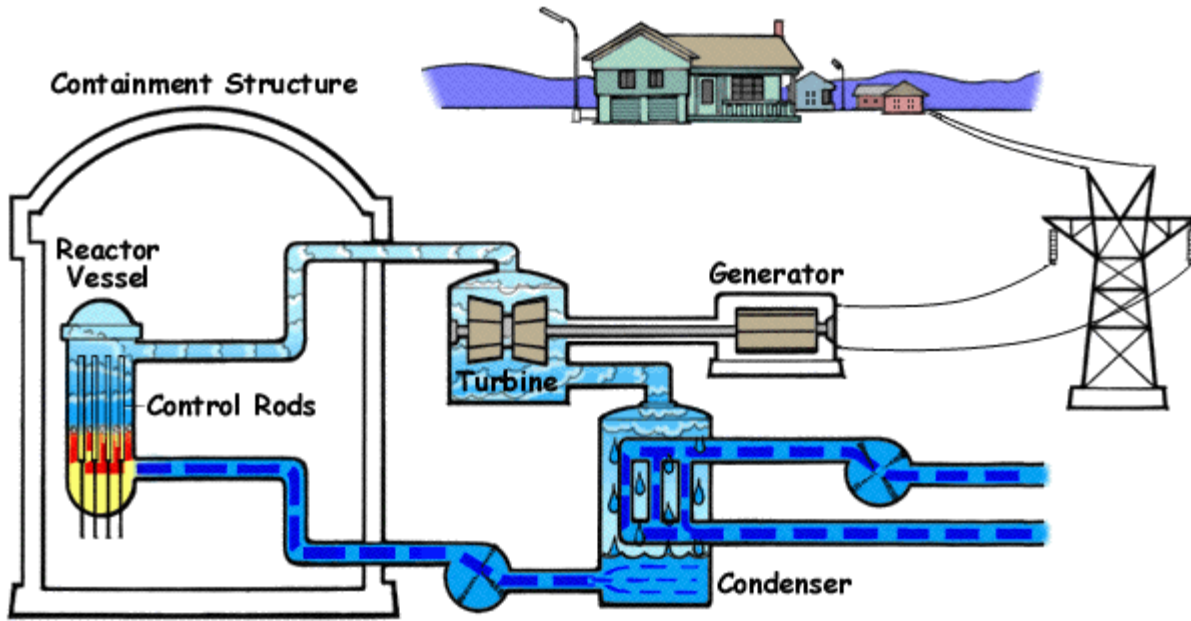

### BWRs

BWRs currently comprise about one-third of the commercial power reactors in the U.S.

Inside the reactor vessel, the reactor pressure is low enough to allow steam formation within the core area. The steam that forms in the core area turns the turbine to generate electricity.

**The steam that is used to turn the turbine of a BWR has come in direct contact with the reactor core.**

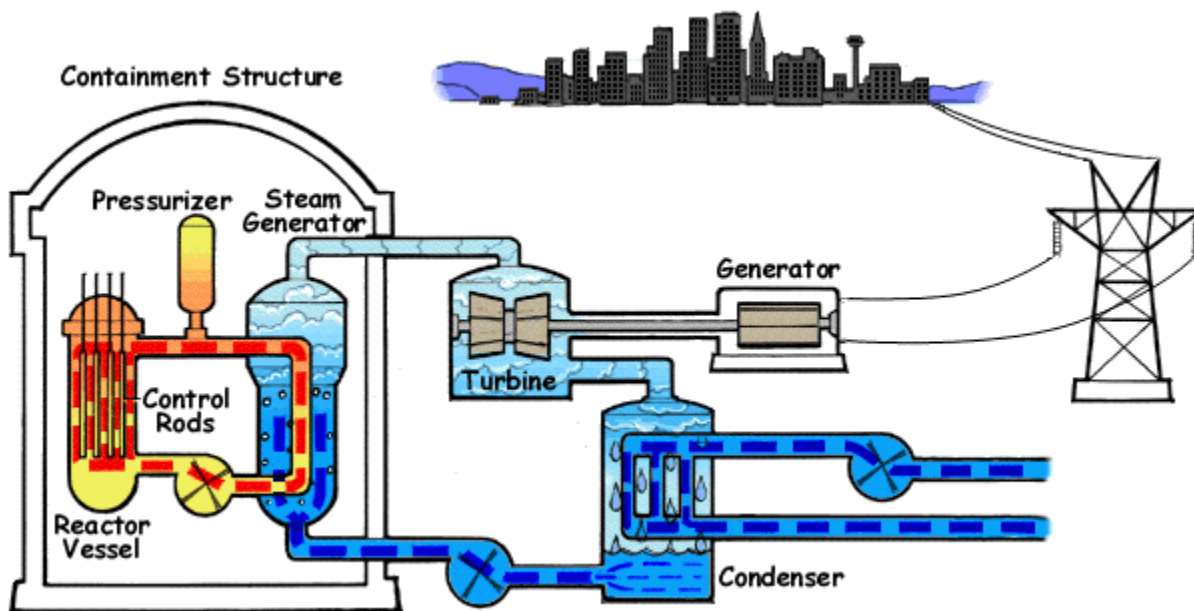

### PWRs

PWRs make up about two-thirds of the power reactors in the U.S.

In a PWR, steam is produced in a separate steam generator rather than in the reactor vessel. A [pressurizer](#) keeps the coolant water in the reactor vessel under very high pressure, which prevents the coolant from boiling.

The hot coolant flows through tubes in the steam generator, where the heat is transferred to the lower pressure feedwater on the outside of the steam generator tubes. The feedwater turns into steam for turning the turbine.

**The steam that turns the turbine of a PWR does not come in direct contact with the reactor core.**



### Check Your Knowledge

**Which items identify the different types of nuclear power reactors?**

Enter the number from the Answer Options in the corresponding field, then select Done.

Answers Options:

1-Boiling water reactor (BWR)

2-Pressurized water reactor (PWR)

- The steam that turns the turbine never comes in contact with the core.
- The steam that turns the turbine comes in direct contact with the core.
- Approximately 1/3 of the nuclear power plants in the U.S. are this type.
- Approximately 2/3 of the nuclear power plants in the U.S. are this type.
- The water and steam are kept under very high pressure.
- The water and steam are kept under low pressure.



### Check Your Knowledge

- **Which items describe nuclear power generation in the U.S.?**

Select all that apply, then select Done.

1. correct:Nuclear power is efficient for large-scale power generation.
2. Nuclear power provides about 47% of the electricity in the U.S.
3. correct:Nuclear power plants are steam electric power plants.

4. Nuclear power plants use raw uranium ore for fuel.
  5. Nuclear fissioning itself generates the electrical output of a nuclear power plant.
- Correct. A nuclear power plant, like other power plants that use steam to generate electricity, is efficient for large-scale power production. Nuclear power plants provide approximately 20% of U.S. power generation. Nuclear fuel assemblies include highly processed uranium in the form of ceramic fuel pellets.
  - Incorrect. A nuclear power plant, like other power plants that use steam to generate electricity, is efficient for large-scale power production. Nuclear power plants provide approximately 20% of U.S. power generation. Nuclear fuel assemblies include highly processed uranium in the form of ceramic fuel pellets.

## Chapter Summary



### Key Points Regarding Basic Electrical Generation Using Steam

- Steam electric power plants are the most efficient type of power plant for commercial production of electricity.
- Basic components of a steam electric plant include:
  - Steam supply system for creating the steam
  - Throttle valve for controlling the rate and amount of steam going to the turbine
  - Turbine for providing the motion to the electrical generator
  - Electrical generator for creating the electrical charge
  - Main condenser and cooling system for cooling the steam back into water form, prior to returning it to the steam supply system
  - Feedwater pump for pushing the cooled water back to the steam supply system
- An electrical generator includes a rotor and a stator. The rotor is a magnet that is centered in the coiled wires of the stator. The rotor spins within the stator, creating a magnetic field, which in turn generates an electric current.



### Key Points

- There are three common methods for cooling a steam electric plant with circulating water. They are:
  - Body of water
  - Forced draft cooling towers
  - Natural convection cooling towers
- The most common power plants in the U.S. are:
  - Fossil fuel: including coal, oil, and natural gas
  - Nuclear
  - Hydroelectric
- Alternative sources are being researched, but are not yet feasible, for large-scale power production. Alternatives sources include:
  - Solar farms
  - Wind farms
  - Bio-fuels



### Key Points

- Although similar to other steam electric power plants, a nuclear power plant has some unique characteristics. They include:
  - A nuclear power plant's energy comes from the fission of fuel atoms.
  - Uranium-235 is the preferred reactor fuel because it is easier to initiate the fission chain reaction.
  - Significant processing must occur to convert the raw ore to usable fuel.
  - Reactor fuel assemblies have the same components regardless of the type of reactor. The components are the fuel rods, the spacer grids, and the upper and lower end fittings.
- Due to the potential ill effects of radiation on the surrounding environment, U.S. nuclear power plants include three barriers to the escape of fission products. The three barriers are the:
  - Cladding
  - Reactor Coolant System (RCS)
  - Containment Building



### Key Points



- Nuclear power plants in the U.S. are designed for safety. They require the intervention of people to continue operation and in the event of a serious accident, are designed to automatically shut down.
- There are two types of nuclear power plants in the U.S.:
  - Boiling water reactors (BWRs) account for approximately 1/3 of the power plants in the U.S. The reactor pressure is low enough to allow steam formation within the core area. In a BWR, the steam that turns the turbine has direct contact with the reactor core.
  - Pressurized water reactors (PWRs) account for approximately 2/3 of the power plants in the U.S. A pressurizer keeps the coolant water in the reactor vessel under very high pressure to prevent the coolant from boiling, even at temperatures of more than 600°F. With a PWR, the steam that turns the turbine never comes in direct contact with the reactor core. Rather, the hot primary coolant passes through a separate steam generator where it gives up its heat to the feedwater and returns to the reactor core.

# Fission Process & Heat Production

## Chapter Introduction



## Chapter Overview

The Uranium atom has a unique ability to split apart and release great quantities of energy. This splitting of the Uranium atom is called fission. Incredibly large numbers of fissions occur every second in order to produce the high temperature, high-pressure steam for the production of electrical power.

This chapter begins by exploring the atomic structure that makes Uranium a useful fuel in harnessing energy within a nuclear reactor. We will continue by examining how a self-sustaining fission reaction is created, maintained, and used to generate large amounts of heat energy. The chapter concludes with a view of the reactor systems designed to support and sustain fission while protecting the environment and the reactor components.



## Objectives

After completing this chapter, you will be able to:

- Describe the relationship between fission and heat production.
- Identify the basics of atomic theory.
- Describe the fission reaction.
- Describe how the fission reaction is used to generate heat.
- Describe the role of fission and heat production in nuclear power generation.

### Estimated time to complete this chapter:

45 minutes

## Review of Atomic Theory

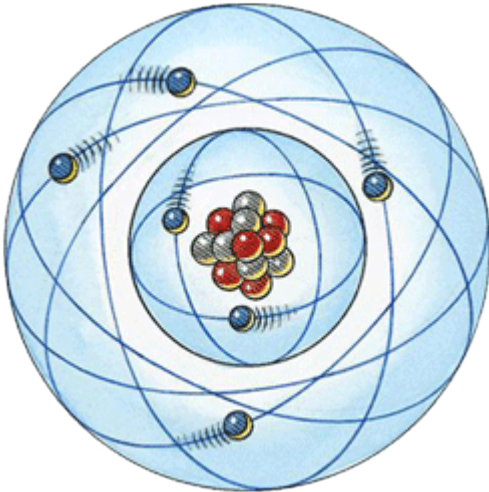

### Inside the Atom

The [atom](#) is the smallest building block for all manner of substances. An atom is composed of positively charged [protons](#), negatively charged [electrons](#), and [neutrons](#). Its structure is similar to a model of our solar system: planets orbit around our central sun. In an atom, the electrons orbit around the atom's nucleus of protons and neutrons.

### Inside the Atom (continued)

The simplest atom is hydrogen, generally composed of one proton and one electron. Because it has just one proton, its [atomic number](#) is 1. A larger atomic number, representing the increasing number of protons, results in a different element (different kind of atom).

Helium, for example, has an atomic number of 2. Two electrons orbit around a nucleus of two protons and two neutrons. Each unique number of protons (positively charged particles in a nucleus) represents a different chemical element.

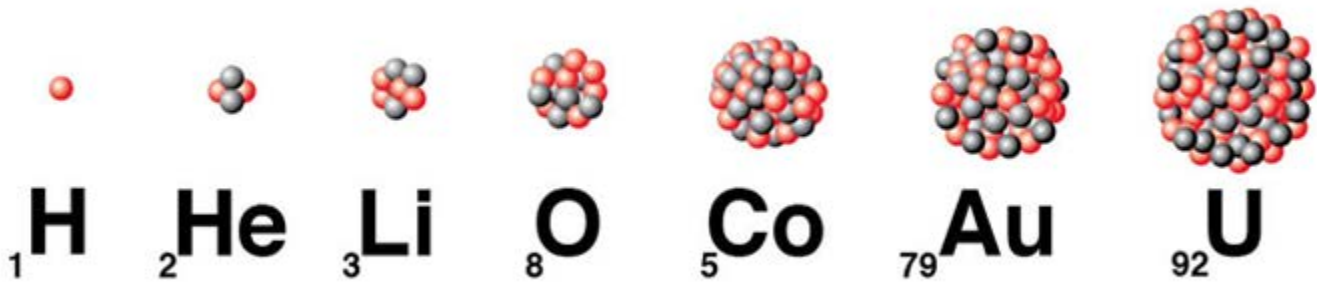

**Periodic Table of the Elements**

Atomic masses in parentheses are those of the most stable or common isotope.

## Periodic Table of the Elements

Each element has a chemical symbol. Elements are listed by increasing atomic number and grouped by similar chemical characteristics in the [Periodic Table of the Elements](#).

A group, or family, is a vertical column in the periodic table. Groups are considered the most important method of classifying the elements. In some groups, the elements have very similar properties and exhibit a clear trend in properties down the group. Groups of elements contain the same number of electrons in their outer shell (orbital); this tends to dictate how they react chemically.

A period is a horizontal row in the periodic table. Although groups are the most common way of classifying elements, there are some areas of the periodic table where the period (horizontal) trends and similarities in properties are more significant than vertical group trends.

	1 IA	New Original	2 IIA
1	1 <b>H</b> Hydrogen 1.00794		
2	3 <b>Li</b> Lithium 6.941		4 <b>Be</b> Beryllium 9.012182
3	11 <b>Na</b> Sodium 22.989770		12 <b>Mg</b> Magnesium 24.3050
	2 <b>He</b> Helium 4.002602		

### Periodic Table of the Elements (continued)

When elements are displayed in a visual format, the chemical symbol appears with a number both above and below the symbol. The number below the symbol represents the isotopic or [mass number](#). This number is a combination of the protons and neutrons within the nucleus of the atom. Sometimes, this number is a whole number representing the most common isotopic mass, or a number showing the *average* weight of all the isotopes of that particular element.

The element helium, for example, is represented as He with a **mass number** of approximately 4.

The number above the symbol is the **atomic number**, or just the number of protons. Often, the atomic number for a specific element will be omitted since this number will never change.

## Electrostatic Force

Similar to the static electricity you would find in clothes pulled from a residential clothes dryer, electrostatic forces act on the particles within an atom. **Like** charges repel and **opposite** charges attract. In elementary school, you may remember pushing pairs of magnets toward each other; the northern magnetic poles would repel each other, as would the southern poles. However, placing a northern and southern magnetic pole near each other would cause them to stick together (attract).

Previously, we explained that all protons within the nucleus of the atom are positively charged. Complex atoms exist with large numbers of protons packed relatively close together. Since like charges repel, some type of force must be present to prevent the like-charged protons from repelling each other and pushing the nucleus apart.

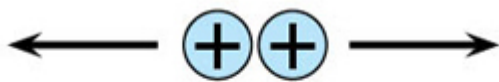

Like Charges Repel



Opposites Attract

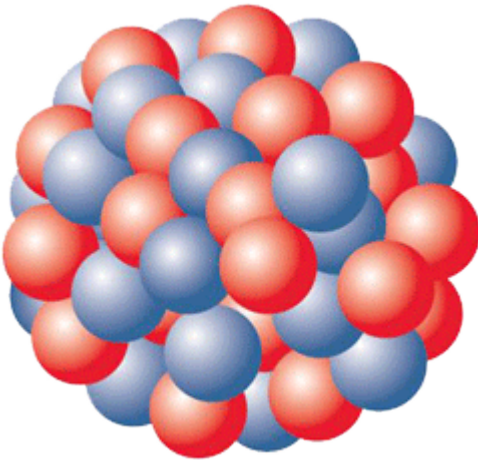

## Neutrons

Electrostatic forces between the positively charged protons in the nucleus try to push them apart. Neutrons, with no electrical charge, provide an attractive—also called binding—nuclear force to offset the repulsive electrostatic forces. This binding force, or nuclear glue, is what holds the nucleus of atoms together.

All atoms found in nature, except the basic hydrogen atom, have one or more neutrons in their nuclei. The number of neutrons in atoms of the same element can vary, creating different [isotopes](#) of that element. As the atomic number increases (more protons in the nucleus), even more neutrons are required to overcome the repulsive electrostatic forces. Once the size of the nucleus increases to a certain size, the elements tend to become less stable: more likely to undergo a transformation. The ratio of neutrons to protons in an atom is directly related to its stability.

Next, we will explore naturally occurring isotopes.

## Isotopes

Many elements have naturally occurring isotopes. Isotopes have a different number of neutrons for each specific element. Listed below are the naturally occurring isotopes of the element carbon. Each isotope has one additional neutron.

The isotopic, or mass, number (shown to the upper left hand of the chemical symbol) is the sum of the number of protons and the number of neutrons in the nucleus of an atom.

Since isotopes exist for all elements, the use of mass numbers is necessary to distinguish one isotope from another. Although the placement of the isotopic number in the upper left is technically correct, many variations are encountered.

The number of protons (representing the atomic number of the element) is located to the bottom left of the chemical symbol.

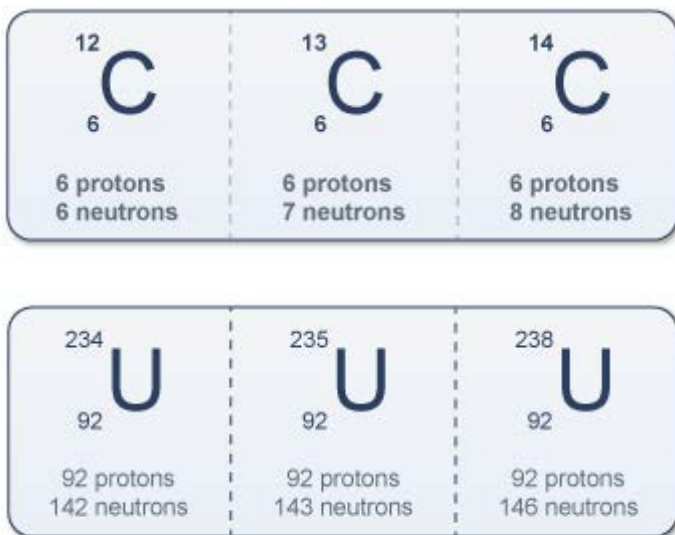

## Naturally Occurring Uranium

The element [Uranium](#) also has naturally occurring isotopes: U-234, U-235, and U-238.

Power reactors in the United States (U.S.) use uranium as fuel. About 99.3% of all uranium atoms in nature are the isotope U-238; most of the remaining 0.7% of the uranium atoms are U-235. Trace amounts (far less than 1%) of U-234 can also be found. Another isotope, U-233, does not exist naturally but it can be manufactured and used to fuel some types of reactors.

We use U-235 for power reactor fuel, as this simplifies the [fission](#) process. Other kinds of isotopes can be induced to undergo fission, but it is generally easier and more practical to use U-235.



## Enrichment

There are facilities that mechanically increase the percentage of U-235 found in naturally occurring uranium (0.7%) to between 3.5 to 5%. This enriched uranium is used to make the fuel pellets in a reactor. This process is called [isotopic enrichment](#).

Naval reactors and nuclear weapons are enriched to much higher levels. The level of enrichment of U.S. power reactors is such that they physically **CANNOT** explode like a nuclear bomb.

The graphic shows U-235 fuel pellets that have been enriched from natural ore.



## Check Your Knowledge

- **Which items accurately describe atomic structure and theory?**

Select all that apply, then select Done.

1. The variation in number of neutrons within the nucleus has little to do with the characteristics of the atom.
2. The isotopic, or mass, number is the combination of the protons and electrons within the nucleus of the atom.



3. correct: The number of neutrons in atoms of the same element can vary, creating different isotopes of that element.
  4. U-235 is selected as fuel in nuclear power plants because it is the most abundant isotope.
  5. correct: Nuclear weapons are enriched to a much higher level of uranium than fuel for nuclear reactors.
- Correct. The isotopic, or mass, number is the combination of the protons and neutrons within the nucleus of the atom. The number of neutrons in atoms of the same element can vary, creating different isotopes of that element. We use U-235 for the fuel, as this simplifies the fission process. Other kinds of isotopes can be induced to undergo fission, but it is easiest to use U-235.
  - Incorrect. The isotopic, or mass, number is the combination of the protons and neutrons within the nucleus of the atom. The number of neutrons in atoms of the same element can vary, creating different isotopes of that element. We use U-235 for the fuel, as this simplifies the fission process. Other kinds of isotopes can be induced to undergo fission, but it is easiest to use U-235.

## Fission and Heat

### Fission and Heat

We have learned that the naturally occurring isotope U-235 is a desirable fuel for nuclear reactors due to its high probability of absorbing a neutron, which then results in fission. Once enriched, U-235 can more easily sustain a fission reaction releasing great quantities of energy and more neutrons.

Let's explore the fission reaction in detail.

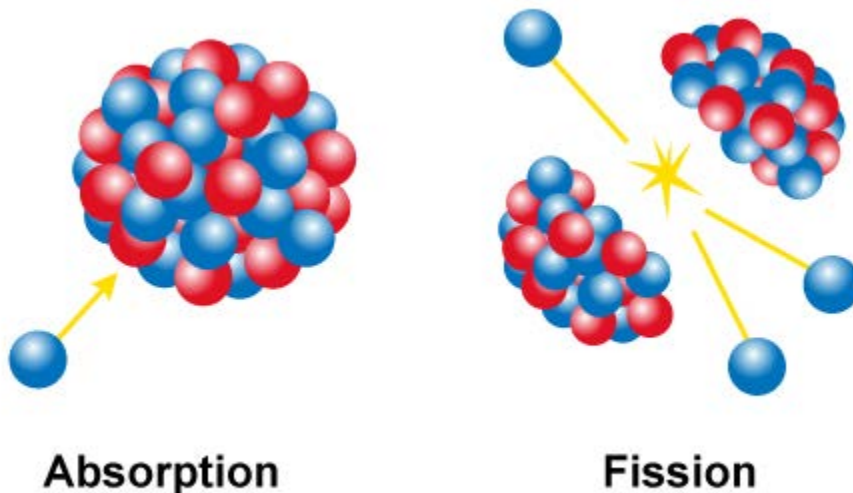

### Fission of the Uranium Isotope

Isotopes are the key to the fission reaction. We will now explore how Uranium-235 is useful as a reactor fuel.

#### Absorption

U-235 is useful as a reactor fuel because it will readily absorb a thermal (lower energy) neutron to become the highly unstable isotope U-236. Due to its unstable nature, 80% of all U-236 isotopes will fission (split).

## Fission

The fission of U-236 releases energy (mostly in the form of kinetic energy of the fission products), which is used to heat the reactor coolant water, produce high-pressure steam and, ultimately, electricity.

On the downside, however, this fission process releases fission products that are highly [radioactive](#) and can linger for a long time, up to tens of thousands of years. The fission products will decay, which also produces more heat. This heat must be continually removed even after the reactor is shut down.

## Supporting the Fission Reaction

U-235 has a relatively high probability of absorbing a neutron. However, the probability increases even more if the neutron is moving more slowly. Therefore, in the reactor, it is desired to slow the neutrons down and then let the U-235 absorb them. This slowing down process is accomplished by the same water used to remove the heat from the fuel. Therefore, the water circulating through the reactor (called the reactor coolant) has two important functions: heat removal and thermalizing, or slowing, neutrons.

### Heat Exchange

First, the water removes the heat from the reactor core to produce the steam used in the turbine. This also prevents the fuel from becoming too hot, which could lead to fuel damage.

### Thermalization

Most neutrons created by fission are born as fast, or high energy, neutrons. The fissioning of U-235 is best accomplished with thermal, or slow, neutrons. Therefore, the neutrons must be slowed down, or thermalized. The “slowing down” process is called [thermalization](#) or moderation.

The coolant water is used to control the fission process by slowing the neutrons down and by acting as a reflector to bounce back any high energy (fast) neutrons that try to escape. This conserves the neutron population so that even more fissions may occur.

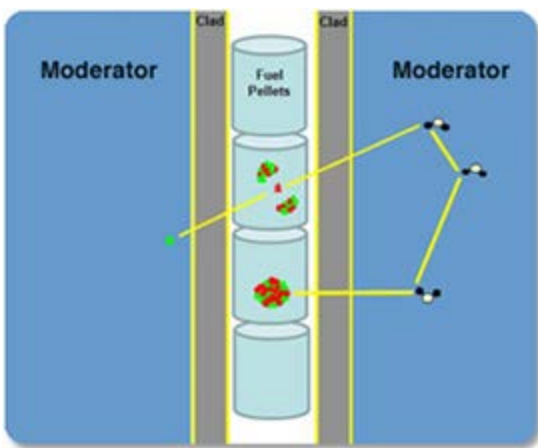

## Neutron Life Cycle

Inside the fuel pellets, U-235 absorbs a neutron, creating an unstable U-236 isotope. Fission of the U-236 isotope releases energy, radiation, and generally two to three new neutrons. The released neutrons are then

available to be thermalized and absorbed by other U-235 isotopes; thus the fission reaction can continue on its own.

Slower moving neutrons stand a greater chance of being absorbed by U-235. Water inside the reactor slows down a neutron through collisions, increasing the probability of it being absorbed.

The water circulating through the reactor (called the reactor coolant) serves two important functions. First, the water carries the heat from the reactor core to produce the steam used in the turbine preventing the fuel from becoming too hot, potentially leading to fuel damage. Second, the water is used to control the fission process by slowing the neutrons down and acting as a reflector to bounce back any high energy neutrons that try to escape. This conserves the neutrons so that even more fissions may occur.

Imagine: On a pool table, a cue ball that strikes another cue ball will transfer more of its energy and slow down faster than if it strikes a bowling ball. We use water to slow the neutrons since the nucleus of the water's hydrogen atoms are protons: essentially the same size as a neutron.

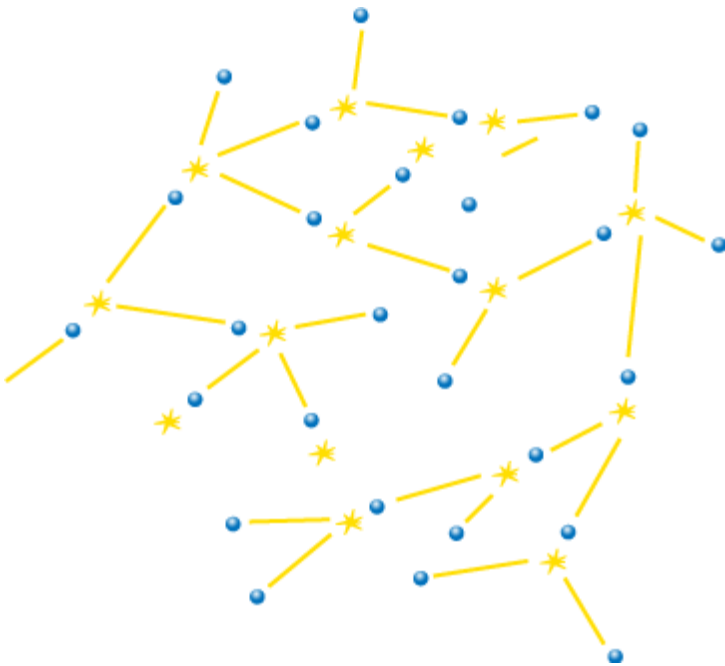

## Fission Chain Reaction

Every fission event releases a tiny amount of heat. Therefore, an incredibly large number of fissions are necessary to produce the high-temperature, high-pressure steam for the production of electrical power. The rate at which the uranium atoms are fissioned determines the rate at which heat (and power) is produced.

Since neutrons are necessary to cause the fission event, and since each event of fission releases more neutrons, there is the potential to set up a self-sustaining chain reaction. For this to occur, there must be sufficient material (fuel) capable of fissioning, and the material must be arranged so that the neutrons will reach other fuel atoms before escaping.

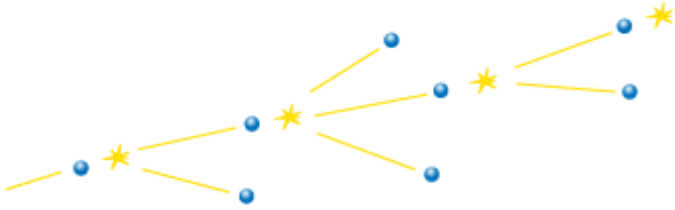

## Criticality

If conditions in the reactor core are suitable, the chain reaction reaches a self-sustaining state. At this point, for each fission event that occurs a second fission will occur. This point of equilibrium is known as [criticality](#).

If you remember from before, each fission of U-235 produces 2 or 3 new neutrons. If each of these neutrons causes a subsequent fission, you can see that the chain reaction would proceed exponentially and power would become uncontrollable. However, most of these neutrons ‘born’ from fission will either leak out of the core area or be absorbed by some material that will not result in a fission.



## Check Your Knowledge

- **Which items accurately describe the process of fission within a nuclear reactor?**  
Select all that apply, then select Done.
  1. correct:The water circulating through the reactor has two important functions: heat exchange and thermalization of neutrons.
  2. correct:Fission of the U-236 isotope releases energy, radiation, and from two to three neutrons.
  3. Since few neutrons are lost during fission, a small number of neutrons are needed to reach criticality.
  4. correct:U-235 is useful as a reactor fuel because it will readily absorb a neutron to become the highly unstable isotope U-236.
  5. Heat production is limited during fission and must be captured quickly for the generation of electricity.
- Correct. U-235 is useful as a reactor fuel because it will readily absorb a neutron to become the highly unstable isotope U-236. Due to its unstable nature, 80% of all U-236 isotopes will fission producing mostly heat. Fission of the U-236 isotope releases energy, radiation, and from two to three neutrons. The reactor coolant water is used for heat exchange and thermalization of neutrons. A large amount of neutrons is needed to balance out absorption and leak out.

- Incorrect. U-235 is useful as a reactor fuel because it will readily absorb a neutron to become the highly unstable isotope U-236. Due to its unstable nature, 80% of all U-236 isotopes will fission producing mostly heat. Fission of the U-236 isotope releases energy, radiation, and from two to three neutrons. The reactor coolant water is used for heat exchange and thermalization of neutrons. A large amount of neutrons is needed to balance out absorption and leak out.

## Fission in a Nuclear Reactor

### Lost Neutrons

As stated earlier, a single neutron can cause U-235 to fission, thus releasing around 2–3 more neutrons. One can see, then, that all the neutrons produced by the fission process do not end up causing subsequent fissions or the chain reaction could take off uncontrollably (like at Chernobyl). The majority of neutrons produced by the fission process are not absorbed by U-235, causing further fissions; most either leak out of the fuel area or are absorbed by materials in the core that do not fission. Materials that absorb neutrons without causing fission are called neutron poisons.

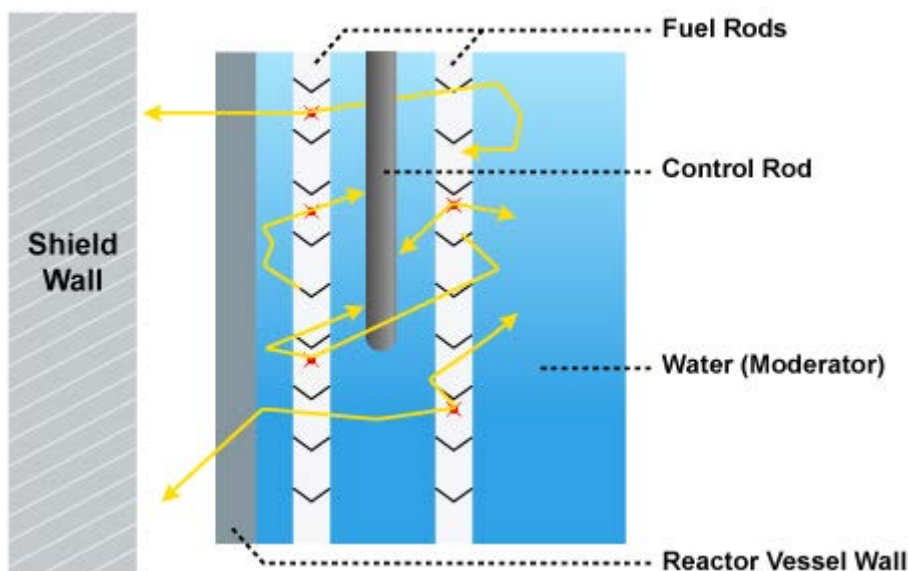

### Neutron Leakage Out of Core

Some of the neutrons released by fission leak out of the reactor core area and are absorbed by the dense concrete shielding around the reactor vessel. Instruments that detect neutrons are placed in this shielding around the reactor vessel, allowing operators to estimate the power being produced by the core. The neutrons that remain within the core area are absorbed by the materials from which the various core components are constructed (U-235, U-238, steel, control rods, etc.). Some of these neutrons absorbed in the various core materials cause fission; however, most are absorbed in non-fissile materials.

The graphic to the right shows the path (in yellow) of neutrons traveling through the core. They bounce off of various materials, especially the hydrogen in the water/coolant. The neutrons may completely escape the core, be absorbed in fuel creating more fissions, or be absorbed in neutron poisons (e.g., rods) or other non-fissioning materials.

**Neutron Poisons:** 

- Control Rods
- Soluble Boron
- Fission Products
- Uranium-238
- Structural Components

## Neutron Poisons

Any material that absorbs neutrons and does not fission is a [poison](#) to the fission process. The reactor vessel, structural components, and the reactor coolant all absorb neutrons. The new elements formed from the splitting of the large U-235 nucleus, known as [fission products](#), also absorb neutrons. Xenon-135 and samarium-149 are two important examples of these uranium fission products that readily absorb neutrons. When these poisons absorb neutrons they impact the number of neutrons available to cause fission of uranium, impacting the power produced by the core. These fission product poisons can affect core power without the operator doing anything; therefore, their effects must be monitored closely.

In both BWRs and PWRs operators can insert and withdraw control rods that absorb neutrons, thus affecting power level.

Also, in pressurized water reactors (PWRs), operators routinely add or subtract the element boron to the reactor coolant. This dissolved boron in the reactor coolant will readily absorb neutrons, making it a strong poison.

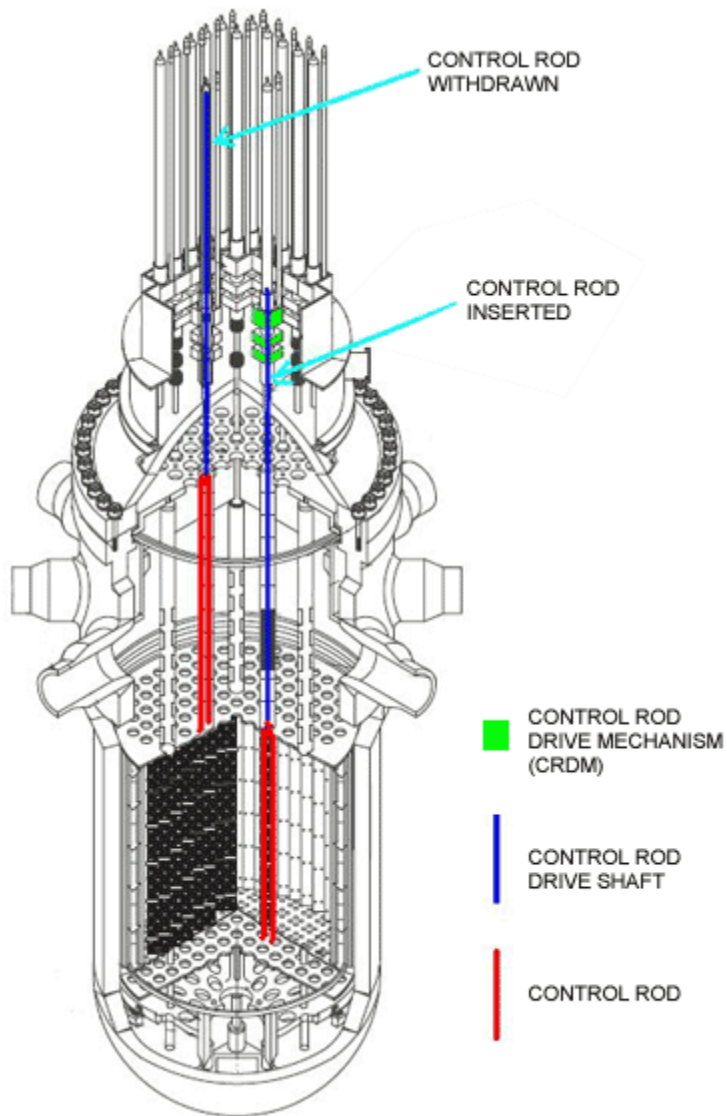

## Control Rods

[Control rods](#) are concentrated neutron absorbers (poisons) that can be moved into or out of the core to change the rate of fissioning in the reactor.

Rods IN - Fewer Neutrons - Power Down

Rods OUT - More Neutrons - Power Up

Rod insertion adds neutron poisons to the core area, which makes fewer neutrons available to cause fission. This causes the fission rate to decrease, resulting in a reduction in heat production and power. Pulling the control rods out farther has the opposite effect: it increases available neutrons, causing heat and power to rise.

The graphic to the right shows the control rod arrangement for PWRs. In the BWR chapter, you will see that control rods insert from the bottom, up.

## Reactor Coolant Water

[Coolant](#) water helps produce a steady rate of reactor power. Water reflects escaping neutrons back into the core and slows neutrons down just enough to facilitate absorption by the U-235 isotope. Despite water's effectiveness as a moderator it also can absorb neutrons, thus causing the removal of neutrons from the fission chain reaction.

First, water has some capacity to absorb neutrons—thus acting as a neutron poison. More importantly, the physical characteristics of the water dramatically affect its success as a [moderator](#).

## Moderating Effects of Coolant Water

Have you noticed water vapor rising from a hot cup of tea or coffee? As the water is heated it becomes less dense, turns to vapor, and rises up through the cooler surrounding air.

The same temperature-to-density relationship is true for the coolant water inside a reactor. If the reactor coolant temperature increases, the water becomes less dense. This means that the water becomes less effective at slowing and reflecting the neutrons. Conversely, as the coolant temperature decreases, its density increases, improving its moderating potential.

If the only action to occur was a change in the temperature of the moderator, power would also change. This moderator temperature effect is a major factor in the control of the fission process and heat production of the reactor.

Remember this when you review the Chernobyl Accident in Module 11. You will see that this water density change characteristic had a huge effect on that accident.

## Voids

There is a point where the temperature of water dramatically affects the fission reaction rate and power production. As the coolant reaches the boiling point, steam bubbles begin to form creating [voids](#) in the reactor coolant. A void is an area of very low density water, or steam.

Water at the bottom of the core is far more dense than the water-steam mixture at the top. Therefore, neutron moderation is much better toward the bottom of the core. The effect of voids on moderation, and therefore power, are large in a BWR.

A [pressurized water reactor](#) (PWR) avoids the issue of void effect by maintaining pressure in the reactor coolant high enough to prevent boiling. Therefore, the effects of voids on the power production in a PWR are minimal.

## Inherent Stability of Light Water Reactors (LWR)

Previously we explained that the temperature/density relationship is an important safety feature of U.S. [light water reactors](#) (LWRs). For example, as fission intensifies in a boiling water reactor (BWR), more heat is generated and then transferred to the reactor coolant water. As fission increases, more coolant water boils. This



creates voids (steam bubbles), allowing more neutrons to escape from the core or to reduce the slowing down (thermalization) of neutrons that don't escape. Fewer neutrons would then be feeding the fission chain reaction, reducing the power and therefore the amount of heat generated.

Coolant water flow can also be increased to lower the temperature and reduce voids. As mentioned previously, the cooler water has a positive moderating effect, thereby increasing reactor power.

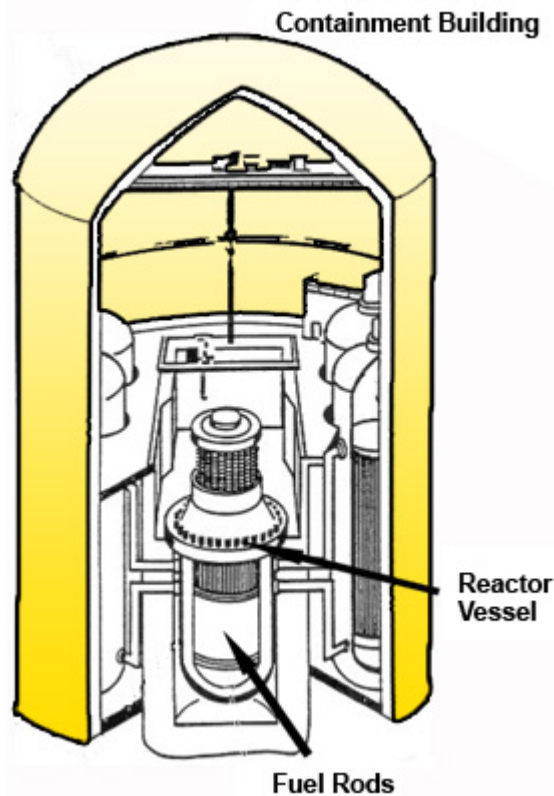

## Fission Product Decay

As discussed previously, fission products are smaller atoms formed when larger uranium atoms are split during the fission process. Many of these fission products that are neutron absorbers (poisons) must be compensated for by removing some of the controllable poisons. In addition to being neutron poisons these byproducts release heat and radiation, which must be contained or eliminated by the reactor systems.

The fission products are usually highly radioactive. They emit a large amount of radiation, therefore they must be contained within the plant. A system of barriers has been developed to prevent these atoms from escaping into the environment. These barriers are the fuel [cladding](#), the reactor coolant system pressure boundary including the vessel, and the [containment](#).

## Fission Product Decay

### Decay Heat

[Radioactive decay](#) of fission byproducts releases a large amount of energy. This energy, called [decay heat](#), can build in the fuel and must be removed by cooling the irradiated fuel even after the reactor fission process is

stopped. An excessive buildup of decay heat in the reactor fuel caused the Three Mile Island core melt-down, which will be further explained in Chapter 10.

Redundant safety systems are designed into the plant to remove this heat after the plant is shut down. Radiation, decay heat, and fission product barriers will all be discussed in greater detail in subsequent sections of this course.

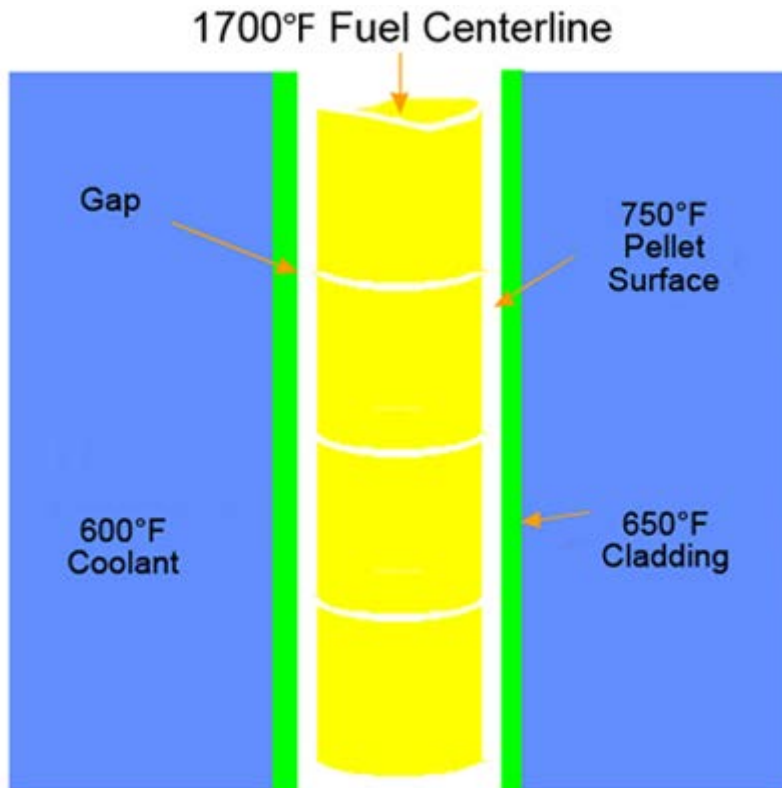

## Fuel Rod Temperatures

When a reactor is operating at full power, under normal conditions, the fuel pellet has an average temperature of about 1400°F. It is about 1700°F at its centerline and 750°F at the pellet surface. Heat is transferred through the gas-filled gap between the fuel pellet and clad, and the outer clad surface is about 650°F.

The melting temperature of the ceramic fuel is approximately 5200°F. The fuel cladding can be damaged by temperatures in excess of 1800°F. Significant clad damage can be expected at sustained temperatures above 2200°F, including a reaction between the clad and water that produces flammable hydrogen gas.

If conditions approach an operating limit, the reactor protection system will rapidly insert the control rods to shut down the fission chain reaction, which removes the majority of heat production. This rapid insertion of rods into the core to shut down the reactor is called a reactor [trip](#) or [scram](#).

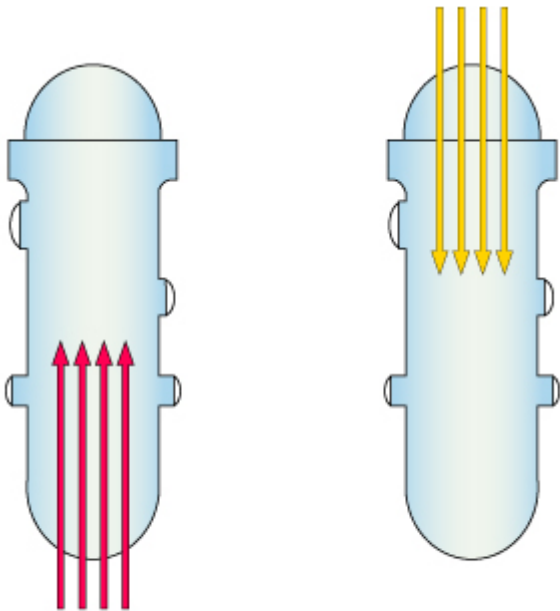

**Rapid insertion  
of control rods**

**Shuts down fission  
chain reaction**

## Reactor Scram

A reactor scram or trip, is the rapid (2 to 4 seconds) insertion of the control rods into the core to stop the fission reaction. Even though fissions are not completely stopped the chain reaction is reduced to below a self-sustaining level, causing a significant decrease in reactor power in just a few seconds. As reactor power is reduced, the heat it produces is also reduced. Plant systems can then easily remove potentially dangerous heat levels produced by the decay heat from fission products.

The most immediate method of reducing the power level in the core is to insert all control rods. The graphic at the right shows a BWR with its rods inserting from the bottom of the vessel, and a PWR with its rods inserting from the top of the vessel.



## Check Your Knowledge

- **Which items accurately describe the process of fission within a nuclear reactor?**

Select all that apply, then select Done.

1. correct:Control rod movement can add or remove neutron poisons.
2. The characteristics of water have little to do with the fission chain reaction, except removing heat.
3. A reactor scram or trip involves circulating great quantities of water to slow the fission reaction.
4. correct:Self-regulation within a BWR is an important safety feature.

- Correct. Control rod insertion adds neutron poisons to the core area, which makes fewer neutrons available to cause fission. Water reflects escaping neutrons back into the core and slows neutrons down just enough to encourage absorption. The temperature/density relationship within water is an important safety feature of U.S. LWRs. The rapid insertion of rods into the core is called a reactor trip or scram.
- Incorrect. Control rod insertion adds neutron poisons to the core area, which makes fewer neutrons available to cause fission. Water reflects escaping neutrons back into the core and slows neutrons down just enough to encourage absorption. The temperature/density relationship within water is an important safety feature of U.S. LWRs. The rapid insertion of rods into the core is called a reactor trip or scram.

## Chapter Summary



### Key Points of Atomic Theory

- Atoms are composed of positively-charged protons, negatively-charged electrons, and neutrons.
- Elements are listed by increasing atomic number and grouped by similar chemical characteristics in the Periodic Table of the Elements.
- Electrostatic forces act on the particles within an atom. **Like** charges repel and **opposite** charges attract. Neutrons provide the binding nuclear force that holds the nucleus of atoms together.
- Isotopes have a different number of neutrons for each specific element. Since chemical elements can have different numbers of neutrons, the use of mass numbers is necessary to distinguish one isotope from another.
- The element uranium also has naturally occurring isotopes: U-234, U-235, and U-238. U-235 is the preferred fuel for the fission process in commercial reactors.
- Fuel enrichment chemically or mechanically increases the percentage of U-235 found in naturally occurring uranium; enrichment takes it from 0.7% to between 3.5 to 5%. This concentrated uranium-235 is used to make the fuel pellets that power U.S. commercial reactors.



### Key Points of Fission and Heat

- U-235 is useful as a reactor fuel because:
  - U-235 will readily absorb a thermal/slow neutron.

- The fission of U-235 releases large amounts of energy, used to produce high-pressure steam for generation of electricity.
- Fission also releases from two to three additional neutrons, which causes other fissions and establishes a self-sustaining chain reaction.
- The reactor coolant water has two important functions:
  - The water absorbs the heat from the reactor core to produce the steam and prevents the fuel from becoming too hot.
  - The water moderates the fission process by slowing the neutrons down and acts as a reflector to help bounce back higher energy neutrons that try to escape. This process is also called thermalization.
- The fission chain reaction will reach a self-sustaining state. Fission of U-235 releases neutrons, which sustains subsequent fissions. This point of neutron equilibrium is known as criticality.

## Key Points of Fission in a Nuclear Reactor

- Materials that absorb neutrons without causing fission are called neutron poisons.
  - Some of the neutrons leak out of the reactor core and are absorbed by the concrete shielding or other components/materials.
  - Neutrons in the core area will be absorbed by the various core components (U-235, U-238, steel, control rods, etc.).
- Control rods are concentrated neutron absorbers (poisons) that can be moved into or out of the core to change the rate of fissioning.
- The physical characteristics of the reactor coolant water dramatically affect its success as a moderator.
  - As the reactor coolant temperature increases the water becomes less dense, reducing its moderating effectiveness.
  - Conversely as the coolant temperature decreases its density increases, which improves its moderating potential.
  - As the coolant reaches the boiling point, steam bubbles or voids begin to form. A PWR mitigates this problem by maintaining pressure to increase the boiling point, limiting steam production.
- The temperature/density relationship is an important safety feature of U.S. LWRs.
  - As fission increases, more coolant water boils allowing neutrons to escape the chain reaction. This reduces the amount of heat/power generated.
  - Coolant water flow can also be increased to lower the temperature and reduce voids. The cooler water has a moderating effect by increasing reactor power.

## Key Points of Fission in a Nuclear Reactor (continued)

- The fission products are usually highly radioactive. A system of barriers has been developed to prevent these atoms from escaping into the environment. These barriers are:
  - Fuel cladding
  - Reactor coolant system pressure boundary
  - Containment
- Radioactive decay of fission byproducts releases a large amount of decay heat, which can build in the fuel pellets or other parts of the barrier systems. Safety systems are designed into the reactor to remove this heat after the plant is shut down.
- Fuel rods and other reactor components can be damaged by excessive heat.
  - Normal Operating Temperatures:
    - Fuel pellet average = 1400°F
    - Clad surface = 750°F
  - Accident Conditions Temperatures
    - Ceramic fuel pellet melting point = 5200°F (decreases with age)

- Fuel cladding damaged at temperatures above 1800°F
  - Significant fuel clad damage results at sustained fuel clad temperatures above 2200°F, which can release fission products from the fuel rods.
- A reactor scram or trip is the rapid (2 to 4 seconds) insertion of the control rods into the core to stop the fission chain reaction.

# Boiling Water Reactor (BWR) Systems

## Chapter Introduction



## Chapter Overview

Recall that [boiling water reactors](#) are one of two types of nuclear power plants in use in the United States (U.S.), and that approximately one-third of the currently active reactors are BWRs. The first commercial nuclear power plant, activated in 1955, was a BWR. Since then, BWRs have evolved as technology and commercial needs have changed. There are currently six different designs of BWRs, five of which are in use in the U.S.

Remember the key differences between a BWR and PWR. With a BWR:

1. The steam that turns the turbine comes in **direct contact** with the reactor core.
2. The water in the reactor core is kept at a relatively low pressure to allow it to boil and produce steam.

In this chapter, we will look at an overview of BWRs; consider the purposes of some of the major systems; and identify components associated with the major systems of a BWR.



## Objectives

After completing this chapter, you will be able to:

- Describe BWR systems, to include the purposes of major subsystems and components.
- Explain commercial electric power generation by a BWR nuclear power plant.
- Identify the primary subsystems of a BWR system.
- Identify the purpose of the key subsystems of a BWR system.

### Estimated time to complete this chapter:

30 minutes

## Overview of BWR Systems

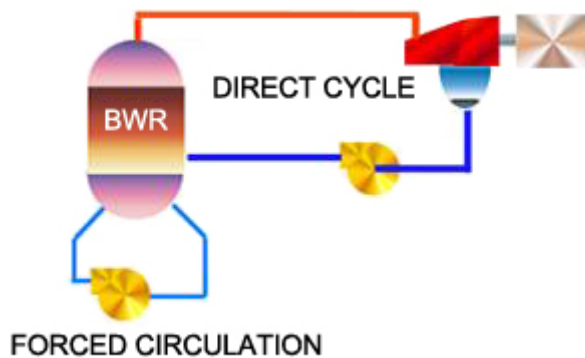

### Evolution of Forced Circulation

As mentioned earlier, BWR designs have evolved over time. In the earliest designs, the flow of water through the core was driven by natural convection. As water was heated and boiled, it rose and incoming colder water replaced it at the bottom of the reactor vessel.

Current BWRs, however, use forced circulation because it allows more direct control of the power in the core. With forced circulation, the amount of power generated by a BWR may be increased by using a mechanical pumping system to force the water through the core.

In this design, a portion of the coolant is taken outside of the vessel into recirculation loops, where it is increased in pressure by means of recirculation pumps. Water at increased pressure is pumped from the recirculation loops back into the reactor pressure vessel.

Recall that the number and size of steam [voids](#) affects neutron moderation and, therefore, power. In a BWR, increasing forced circulation decreases the steam voids, which causes an increase in power.



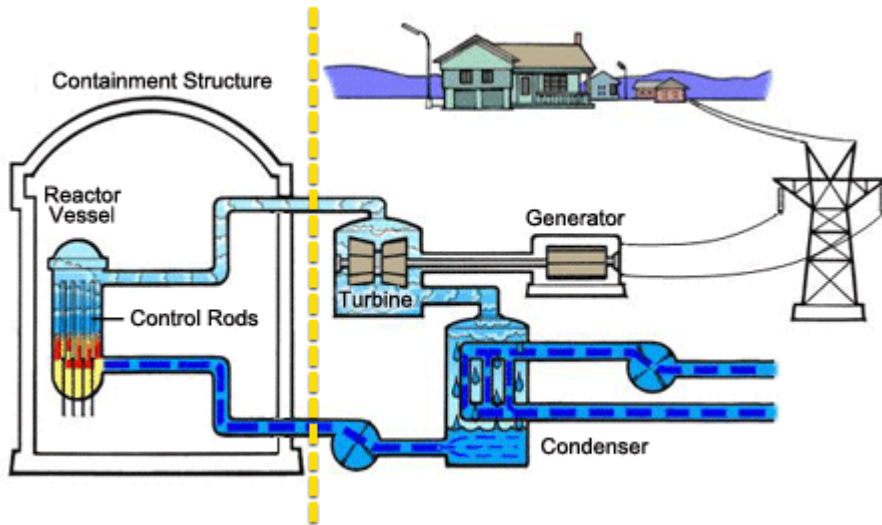

## Primary and Secondary Systems of a BWR

All nuclear power plants can generally be divided into what are known as primary and secondary systems. With a BWR, however, the true dividing line between the two is not as concrete as with a PWR.

For our purposes, we will refer to primary systems as those being within the containment building and secondary systems as those being outside of the containment building. Realize that there may be some systems that don't exactly meet this criteria, or that cross the dividing line.

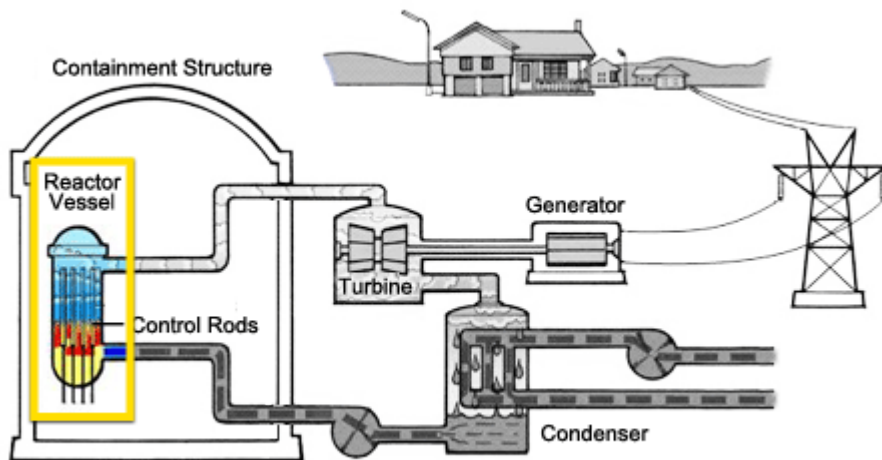

## Basic Functionality of a BWR: Steam Production

Steam production occurs within the primary system. Inside the reactor vessel, a steam/water mixture is produced when very pure water (reactor coolant) flows upward through the core absorbing heat. The reactor pressure is low enough to allow this coolant to change to steam within the core area.

The recirculation and jet pumps allow the operator to vary coolant flow through the core, which changes reactor power by affecting the amount of steam bubbles present.

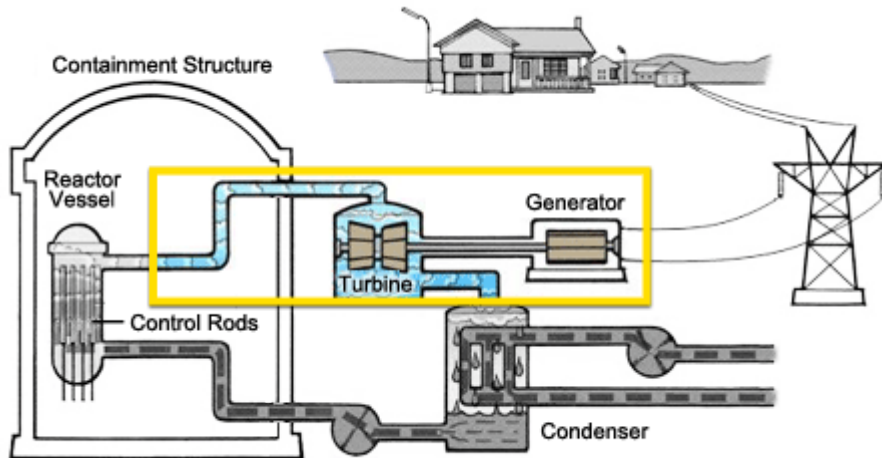

### Basic Functionality of a BWR: Electrical Generation

The steam/water mixture exits the top of the core and enters two stages of moisture separation. Moisture separation occurs within the primary system. Here, the liquid water is removed before the steam is allowed to enter the steam line and is mixed back with incoming feedwater.

The steam exits the reactor vessel (primary system) through the main steam lines and enters the secondary system. In the secondary system, the steam is directed to the main turbine causing it to spin. The spinning turbine is directly connected to the electrical generator; this motion then generates an electro-magnetic potential (voltage) in the attached electrical generator.

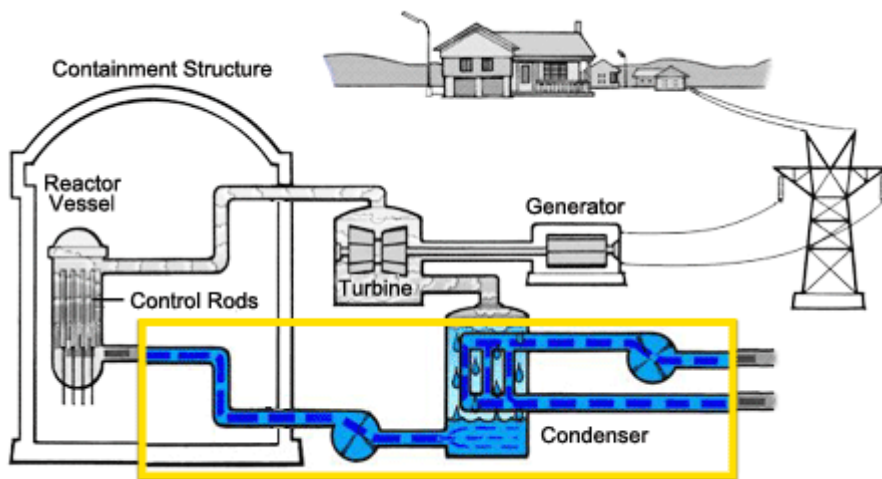

### Basic Functionality of a BWR: Exhaust Steam

The used steam, exhausted from the turbines, is directed to the condenser where it is cooled and condensed back into water. The resulting water (condensate) is pumped out of the condenser with a series of pumps and back to the reactor vessel, as feedwater, to start the process over again.

As you can see, a BWR is a closed system. The water pumped into the reactor becomes the steam for electrical generation. This steam is then recaptured, condensed back into water, and returned to the reactor vessel again as feedwater.



## Check Your Knowledge

- **Which items explain how BWRs generate commercial electricity?**

Select all that apply, then select Done.

1. The steam/water mixture is kept under very high pressure (greater than 2000 psi).
  2. correct: The steam/water mixture is heated within the reactor core.
  3. The operator increases or decreases the reactor power by manipulating the pressure.
  4. correct: The steam that turns the turbine has come in direct contact with the core.
  5. correct: A BWR is a closed system.
- Correct. A BWR system is a closed system. Inside the BWR system, the steam/water mixture is heated within the reactor core, at a pressure that allows it to boil at normal operating temperatures. After coming in direct contact with the core, the steam powers the turbines used to generate electricity.
  - Incorrect. A BWR system is a closed system. Inside the BWR system, the steam/water mixture is heated within the reactor core, at a pressure that allows it to boil at normal operating temperatures. After coming in direct contact with the core, the steam powers the turbines used to generate electricity.

## Functional Systems and Subsystems of a BWR



## Basic Functional Systems

All BWR plants have the same basic functional systems. A functional system may include subsystems that are in the primary system, the secondary system, or both. The basic functional systems of a BWR include:

- Reactor coolant system (RCS)
- Emergency core cooling systems (ECCS)
- Containment system (CONT)
- Process instrumentation & control systems (I&C)
- Secondary systems (SEC)

Let's take a look at each of these systems in more detail. We'll start with the RCS. Keep in mind that different designs of BWRs will have slight differences in the layout and types of these systems; however, they all basically operate the same way.

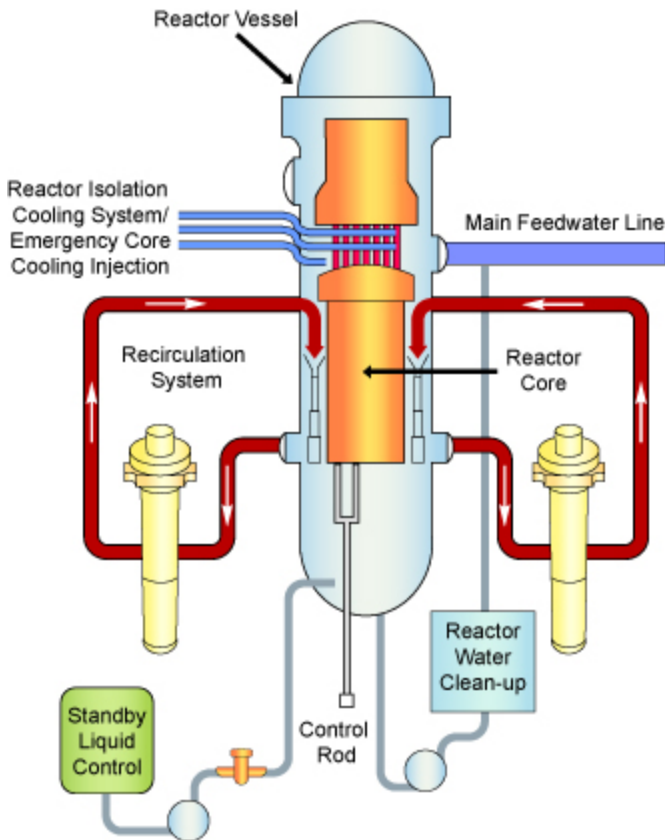

## Reactor Coolant System (RCS)

The RCS allows the operators to maintain and control optimal temperature in the reactor core. Subsystems of the RCS include:

- Reactor vessel & core
- Recirculation system
- Reactor core isolation cooling system
- Reactor water cleanup
- Standby liquid control
- Control rods



## RCS: Reactor Vessel & Core

The reactor vessel assembly consists of the reactor vessel and its internal components. The functions of the reactor vessel assembly are to:

- House the reactor core
- Support and align the fuel and control rods
- Provide a flow path for circulation of coolant past the fuel
- Remove moisture from the steam exiting the core, and direct the steam to the vessel outlet

The reactor vessel is vertically mounted and consists of a cylindrical shell with an integral rounded bottom head. The top head is also hemispherical and can be removed to facilitate refueling. The head is kept in place by massive nuts and bolts. The entire vessel assembly is supported on its lower, hemispherical head by the circular vessel support skirt, which is mounted to the reactor vessel support pedestal.

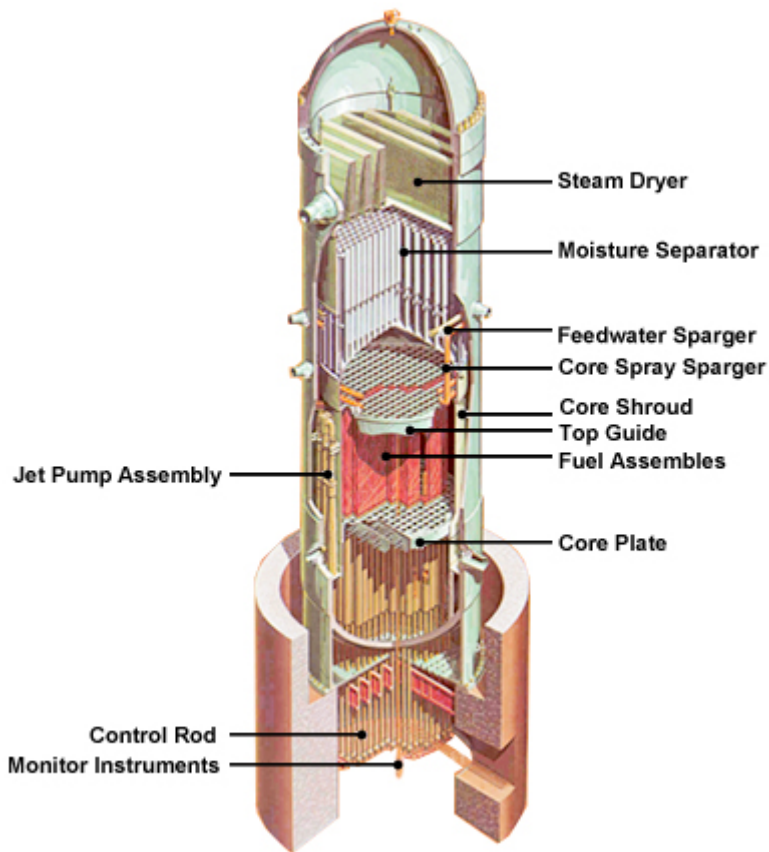

## RCS: Reactor Vessel and Core Components

The components of the reactor core and vessel are:

- Steam dryer
- Moisture separator
- Feedwater spargers
- Core spray spargers
- Top guide
- Jet pump assemblies
- Core shroud
- Fuel assemblies
- Core plate
- Control rods
- Monitoring instruments

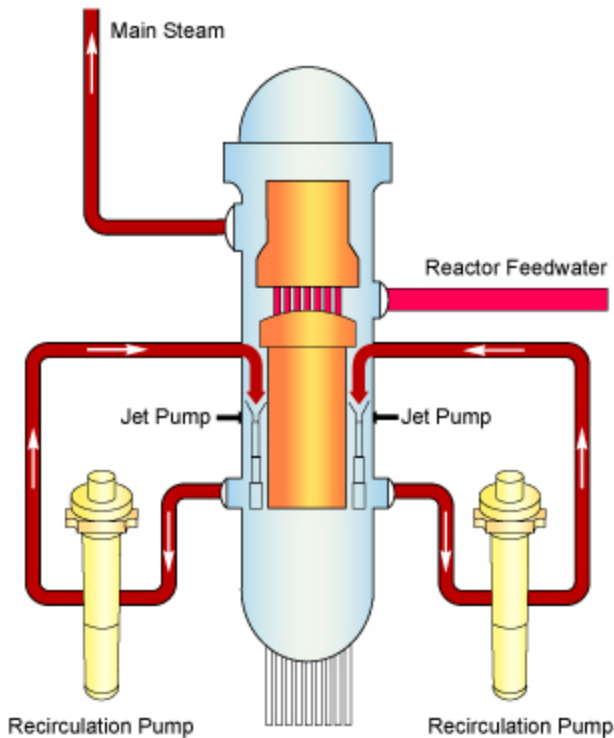

## RCS: Recirculation System

The recirculation system pumps water through the core. Incoming reactor feedwater is mixed with the moisture stripped out of the steam in the vessel moisture separators. A portion of this feed is taken out of the reactor vessel and its pressure is increased by a recirculation pump. The discharge of this pump is re-introduced into the vessel through jet pumps that pick up more feed and push it into the core at higher flow rates than can be achieved with natural circulation alone.

As the flow through the core is increased, the mass/size of the steam bubbles/voids is reduced. This allows better moderation (slowing or thermalization) of the fission neutrons, which increases reactor power. Operators will vary recirculation flow in order to control reactor power and steam flow to the main turbine.

## RCS: Reactor Core Isolation Cooling

The reactor core isolation cooling (RCIC) system supplies high-pressure makeup water to the reactor vessel when the reactor is isolated from the main condenser, and/or when the reactor experiences a loss of the reactor feed pumps.

Basically, following a plant trip, the main steam valves to the turbine will shut, stopping the normal method of removing core heat. The RCIC system will supply steam from the reactor to a separate turbine-driven pump that will add feedwater into the reactor through its normal feed line. This provides a method for removing decay heat and adding coolant to the core.

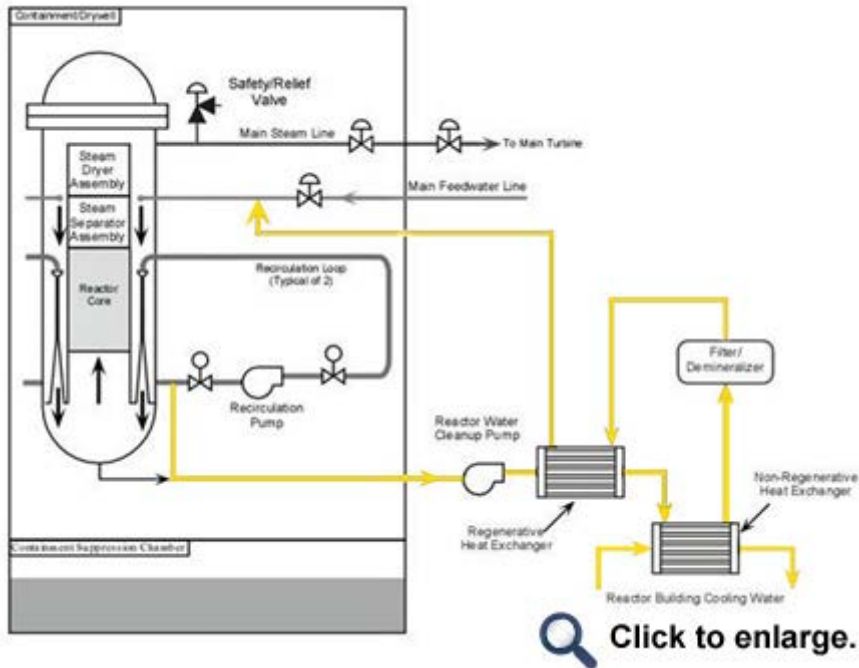

## RCS: Reactor Water Cleanup

The reactor water cleanup (RWC) system maintains high reactor water quality by removing fission and corrosion products and other soluble and insoluble impurities.

The RWC pump takes water from the recirculation system and the vessel bottom head. It then pumps the water through heat exchangers to cool the liquid. Cooling the liquid protects the filter and demineralizer resin. The cooled water is sent through the filter and demineralizers for cleanup.

After cleanup, the water is reheated and returned to the reactor vessel via the feedwater piping.



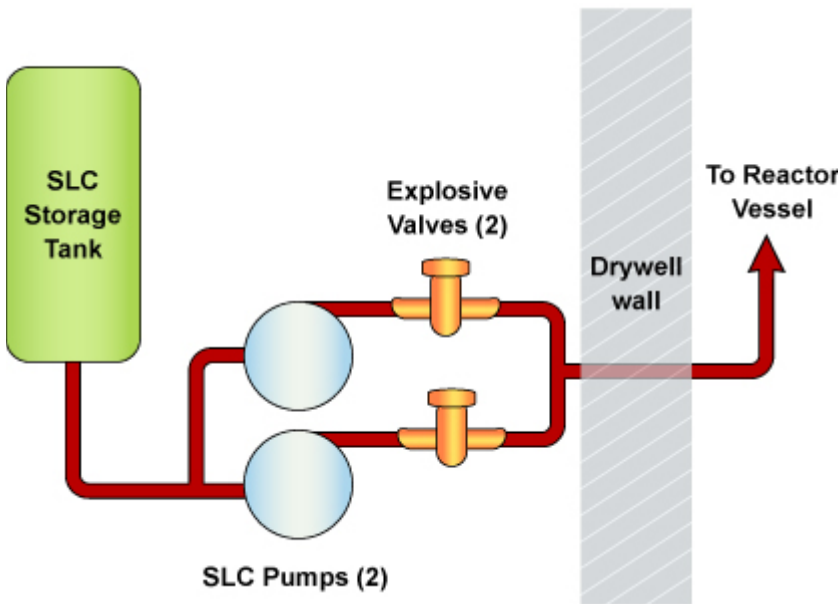
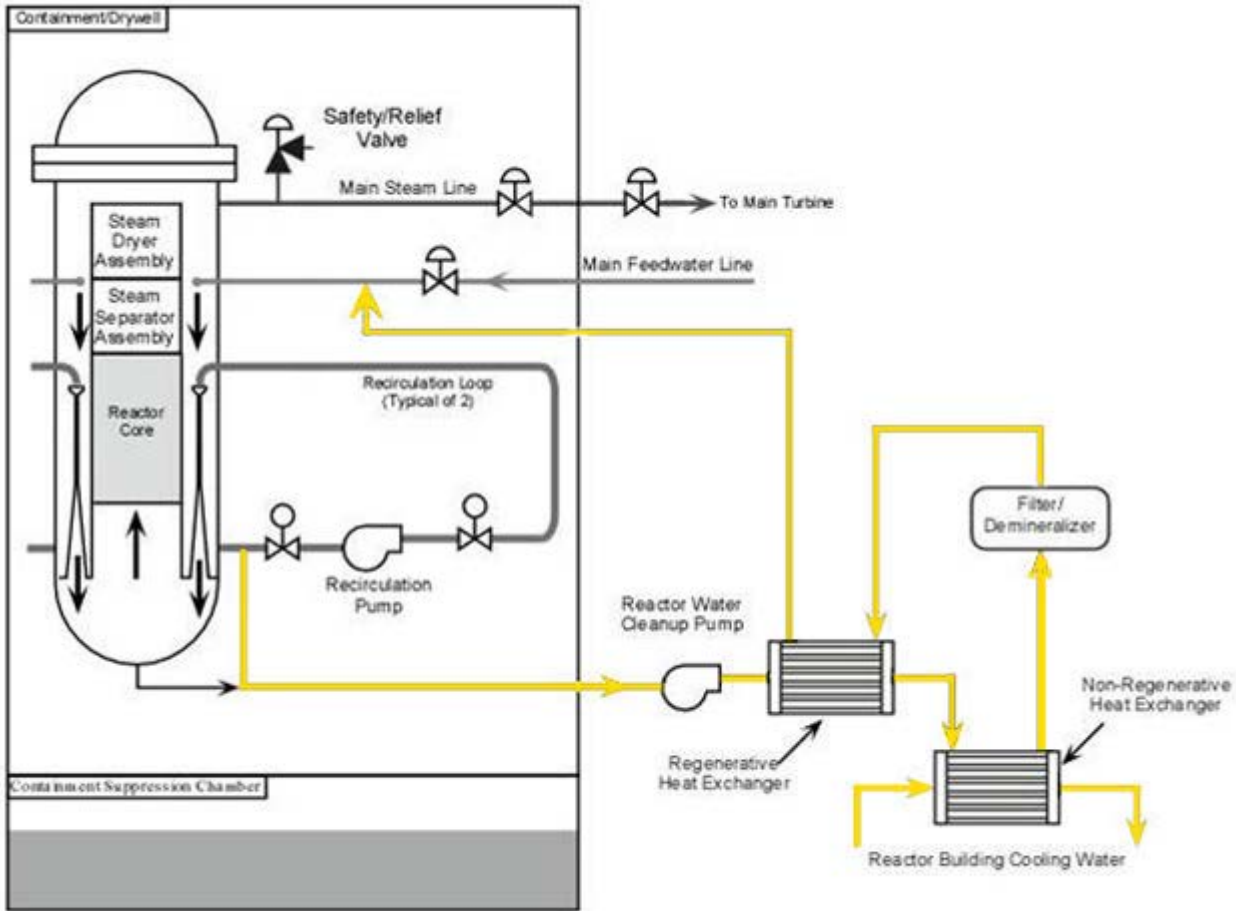

**RCS: Standby Liquid Control (SLC)**

Normally, BWR plants use pure water as coolant, with no boron added, as in PWRs. When it is necessary to shut down the reactor, all control rods are inserted. This is sufficient to make the core subcritical.

In the event of an emergency, operators have the ability to manually add large quantities of boron (a neutron poison/absorber) to the RCS, using the SLC system, to ensure the core is shut down.

The SLC system consists of:

- A heated storage tank containing boron
- Two positive displacement pumps
- Two explosive (squib) valves
- Piping that directs the boron to the reactor vessel



## RCS: Control Rods

In a BWR, except for a few peripheral fuel assemblies, the fuel is arranged in the vessel into control cells. Each control cell consists of a control rod and four fuel assemblies immediately surrounding it.

The four fuel assemblies are supported by a fuel support piece. Around the outer edge of the core, the peripheral fuel assemblies that are not in a cell are supported by individual support pieces.

## Control Rod Drive System

The control rod drive system makes changes in core reactivity by moving the neutron-absorbing control rods in response to the reactor manual control system (RMCS) signals. It rapidly inserts all control rods to shut down the reactor in response to reactor protection system (RPS) signals or a manual SCRAM as called for by operators.

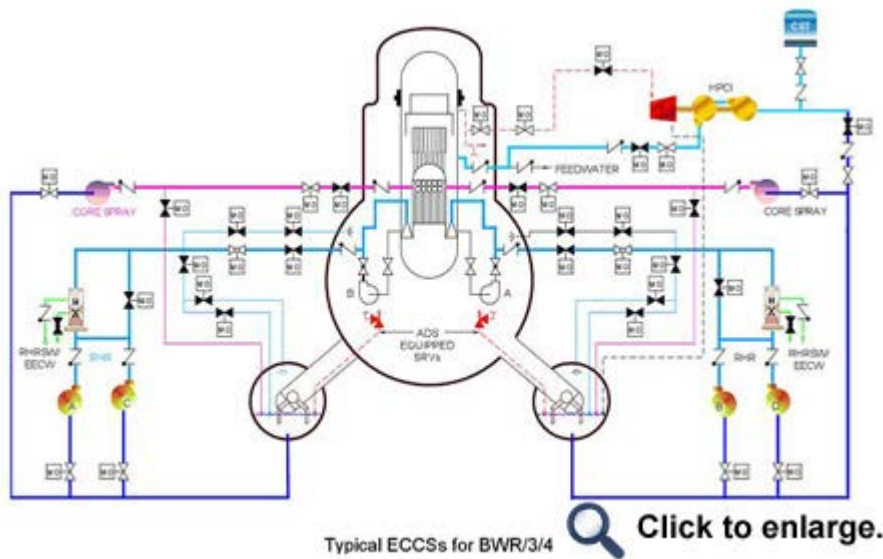

## Emergency Core Cooling System

The emergency core cooling system (ECCS) provides core cooling under loss of coolant accident (LOCA) conditions to limit fuel cladding damage. The ECCS consists of two high pressure and two low pressure systems. Together, the subsystems of the ECCS allow the operators to maintain and control optimal temperature in the reactor core. Subsystems of the ECCS include:

- High pressure systems
  - High pressure coolant injection (HPCI)
  - Automatic depressurization system (ADS)
- Low pressure systems
  - Low pressure coolant injection (LPCI)
  - Core spray (CS)

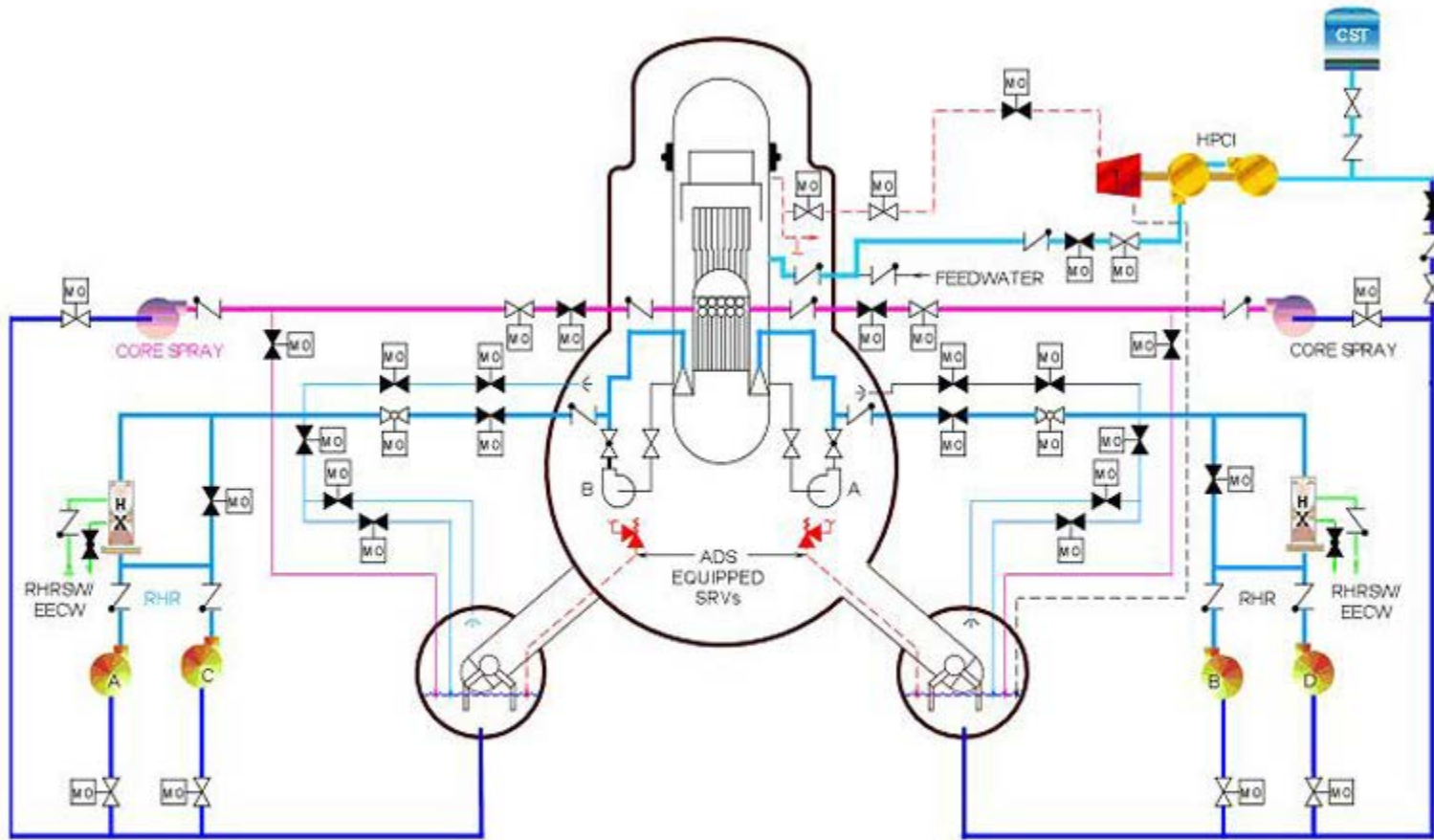

Typical ECCSs for BWR/3/4

 Click to enlarge.

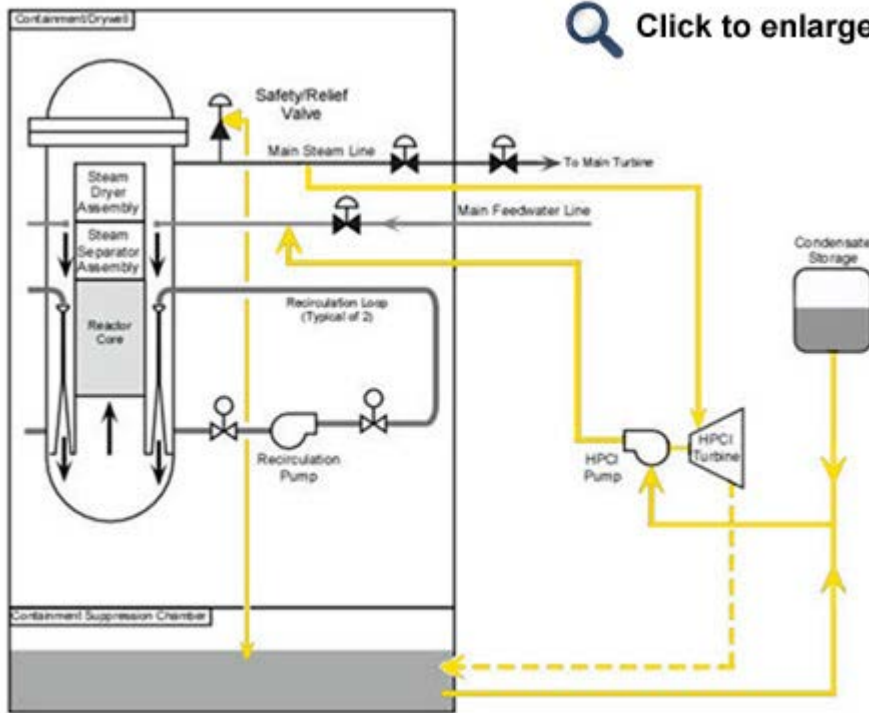

**ECCS: High Pressure Systems**

**High Pressure Coolant Injection**

The high pressure coolant injection (HPCI) system is an emergency core cooling system requiring no AC power, plant air, or external cooling water. It is independent so that a failure of other ECCS systems would not affect its ability to function. The power for running the HPCI pump is steam from the reactor, created by the decay heat of the core.

The HCPI system provides make-up water to the reactor vessel for core cooling for relatively small- and medium-sized LOCAs (leaks). It supplies make-up water from a large storage tank to the reactor at pressures above normal down to where the low pressure ECCS systems eventually can inject.

### Automatic Depressurization System

The automatic depressurization system (ADS) consists of a control system that will open select safety relief valves, as required. Opening the valves depressurizes the reactor for small- or intermediate-sized LOCAs in case the high-pressure injection system is not available or cannot sufficiently recover the reactor vessel water level.

Simply put, the ADS releases steam from the RCS so that pressure drops low enough for the ECCS pumps to inject water into the RCS for cooling.

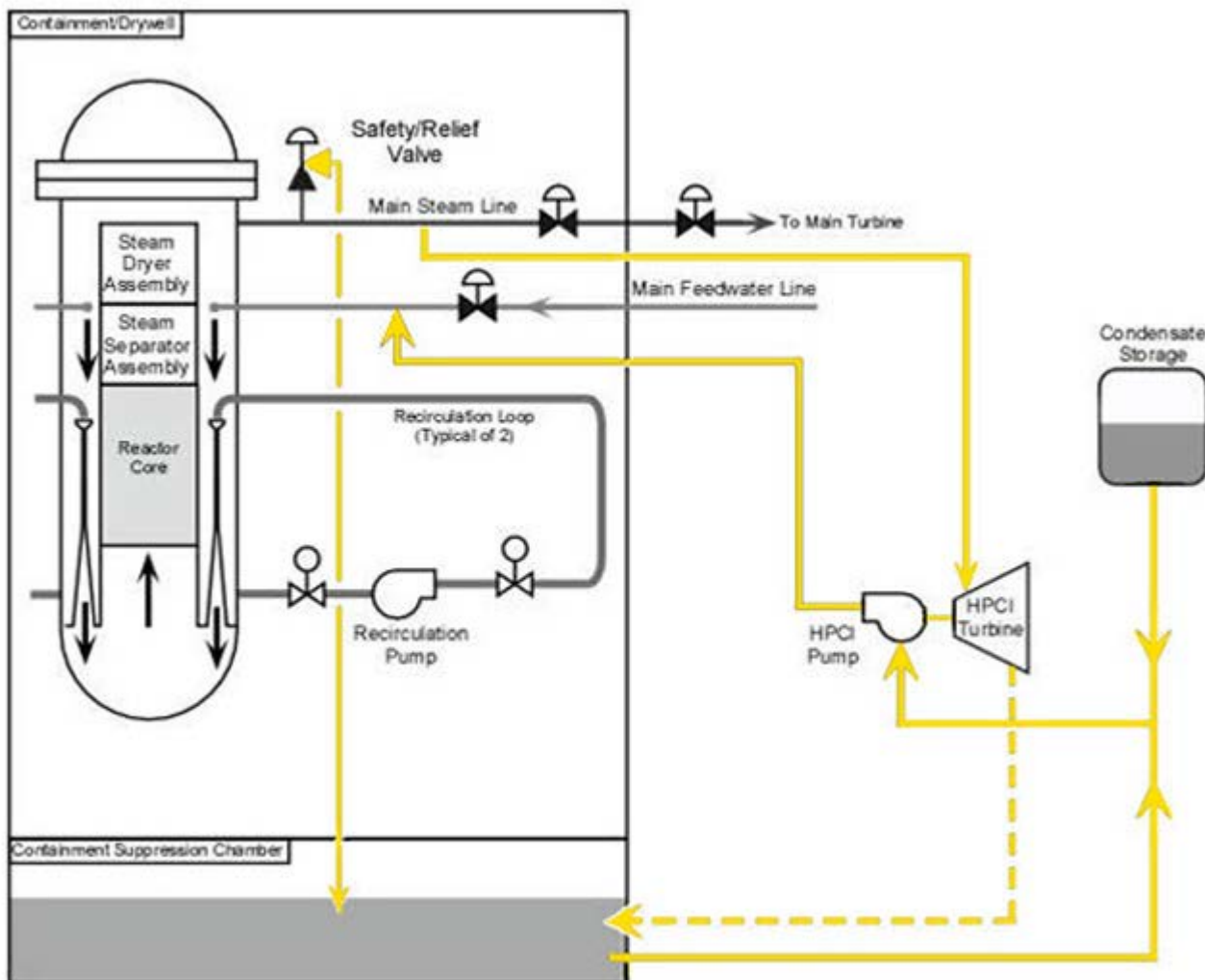

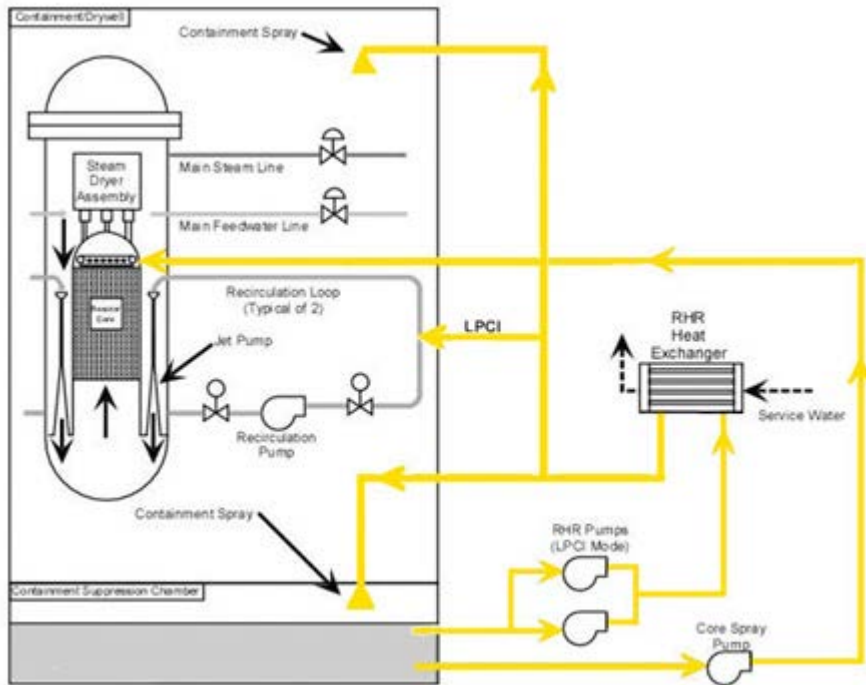

## ECCS: Low Pressure Systems

### Low Pressure Coolant Injection and Residual Heat Removal System

The residual heat removal (RHR) system is a multipurpose system with several operational modes, each utilizing the same major pieces of equipment. The low pressure coolant injection (LPCI) system is the dominant mode and is the normal valve lineup configuration of the RHR system. The LPCI system is used during normal operations.

The LPCI system provides make-up water to the reactor vessel for core cooling under intermediate and large break LOCA conditions. The LPCI mode operates automatically to restore and, if necessary, maintain the reactor vessel coolant inventory to preclude fuel cladding temperatures in excess of 2200°F. During LPCI operation, the RHR pumps take water from the suppression pool and discharge it to the reactor vessel.

The other mode of the RHR system is for during and after shutdown to maintain an appropriate temperature.

### Core Spray

The core spray (CS) system consists of two separate and independent pumping loops, each capable of pumping water from the suppression pool into the reactor vessel. Core cooling is accomplished by spraying water on top of the fuel assemblies.



## Check Your Knowledge

### Which subsystems belong to which main systems?

Enter the number from the Answer Options in the corresponding field, then select Done.

Answer Options:

1 - Reactor Coolant System (RCS)    2 - Emergency Core Cooling System (ECCS)

- Low pressure coolant injection (LPCI)
- Recirculation system
- Reactor water cleanup (RWCU)
- Automatic depressurization system (ADS)
- Core spray (CS)

## Containment System

The containment system (CONT) provided for a particular product line is dependent on the vintage of the plant and the cost-benefit analysis performed prior to plant construction. Over the years the CONT evolved for BWRs, resulting in three progressive designs.

The major containment designs are the Mark I, Mark II, and the Mark III. All three containment designs use the principle of pressure suppression for loss of coolant accidents and include the following subsystems:

- Primary containment
- Secondary containment
- Standby gas treatment

### CONT: Primary Containment

The primary containment is designed to:

- Condense steam and contain fission products released from a loss of coolant accident so that offsite radiation doses specified in 10 CFR 100 are not exceeded
- Provide a heat sink and water source for certain safety-related equipment

For non-sighted users, please use these skip links access the items on the slider.

- [First Image](#)
- [Second Image](#)

## MARK I/II CONTAINMENT

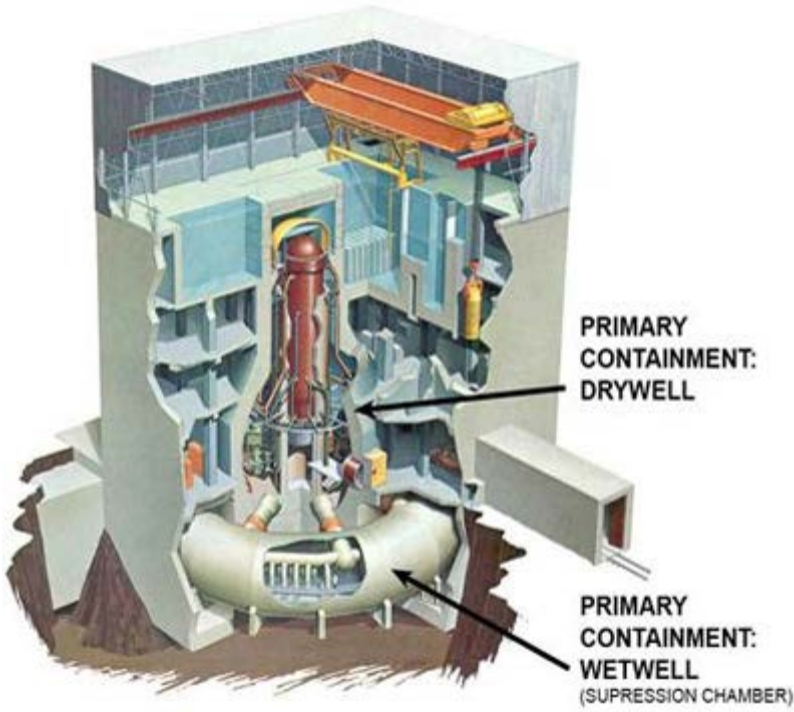

### Mark I and Mark II

Primary containments for the Mark I and Mark II designs include a drywell and a wetwell. The wetwell functions as a suppression chamber.

## MARK III CONTAINMENT

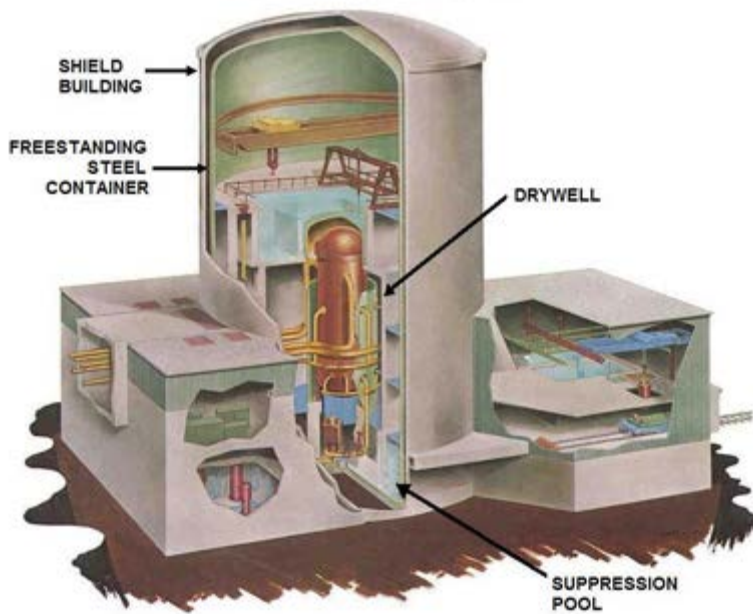

### Mark III



The primary containment for the Mark III design utilizes a suppression pool, versus a wetwell. The function is largely the same: heat energy from the reactor, if not removed by steam to the turbine, can be directed to a large pool of water that can absorb the heat.

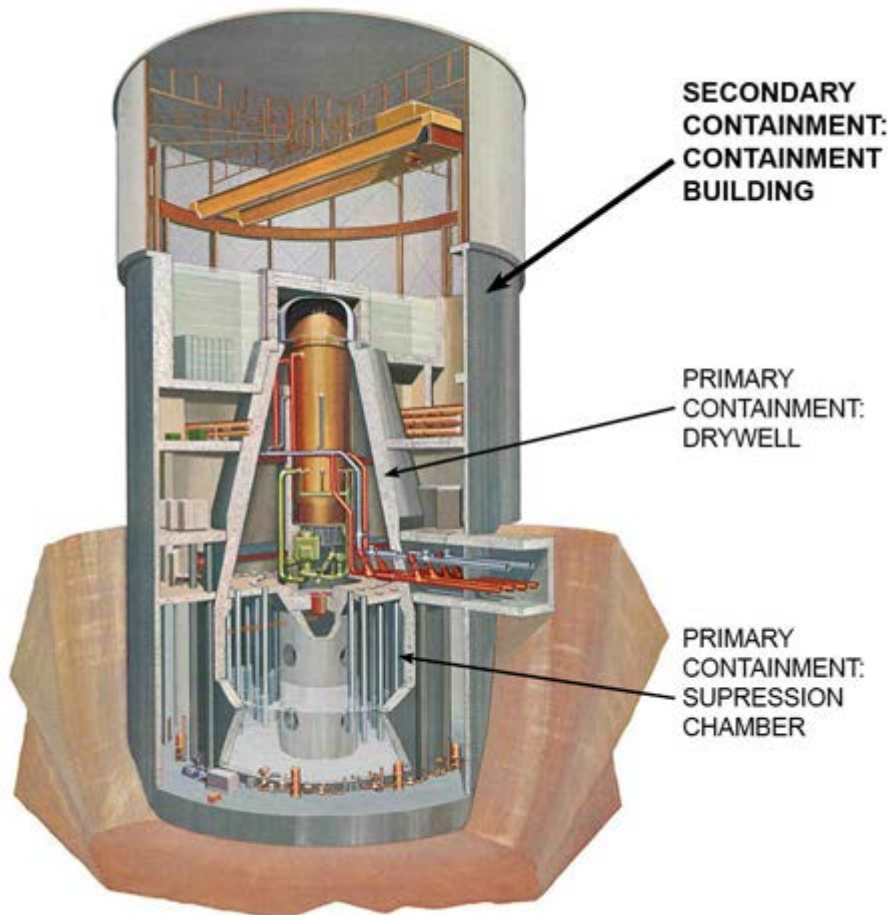

### **CONT: Secondary Containment**

Secondary containment is also known as the reactor building. It surrounds the primary and delineates and houses the spent fuel pool and emergency core cooling systems.

Secondary containment delineates between the primary and secondary systems of a BWR.

All three CONT designs (Mark I, II, and III) include some type of secondary containment.

### **CONT: Standby Gas Treatment (SGTS)**

The SGTS processes exhaust air from the secondary containment during an accident in order to limit the dose rates to the public to within allowable limits. It also maintains a negative pressure in the secondary containment following loss of the normal ventilation system so any leakage is inward, away from the environment. It can also be used to perform containment leak tests and to purge (clean) the primary containment.

The atmosphere inside the Mark I and II containment is made inert with nitrogen gas. This reduces the possibility of an explosion following a loss of reactor coolant. Large amounts of hydrogen can be generated in the reactor vessel if the core becomes uncovered and remains dry for a period of time.

In the Mark III containment design a leak tight, steel containment vessel surrounds the drywell and suppression chamber to prevent gaseous and particulate fission products from escaping. No nitrogen gas is used.



## Process Instrumentation & Control Systems

The process instrumentation and control systems (I&C) allow the operators to effectively monitor the reactor processes and all support processes, and to make corrections to the system when needed.

I&C subsystems include:

- [Reactor protection system \(RPS\)](#)
- [Electro-hydraulic control \(EHC\)](#)
- [Neutron monitoring](#)
- [Feedwater control](#)

The Feedwater Control System regulates the flow of feedwater to the reactor vessel in order to maintain reactor water level. The Feedwater Control System measures and uses total steam flow, total feedwater flow, and reactor vessel water level signals to carry out its function.

Remember that water level in the reactor vessel is important to heat removal from the core.

The purposes of the Neutron Monitoring System (NMS) are to monitor reactor core neutron flux (power level) and provide indication during all modes of reactor operation, and to provide trip signals to the Reactor Protection System (RPS) and the Rod Control System.

The Electro Hydraulic Control System maintains a constant reactor pressure for a given reactor power level; controls the speed and load on the turbine generator, and provides protection for the main turbine.

In essence, as reactor power goes up, the steam valves to the turbine open more, so electrical load goes up. For BWR plants, this is termed: slaving the turbine to the reactor.

The purposes of the Reactor Protection System (RPS) are to automatically initiate a reactor scram to protect the fuel cladding, to preserve the integrity of the reactor coolant system, and to minimize the energy which must be absorbed following a loss of coolant accident (keep the containment intact).

Multiple, redundant systems monitor key plant parameters and will quickly shut the reactor down if conditions deteriorate. The system requires more than one of the same parameters to be bad in order to prevent a failed instrument from causing a scram.

test

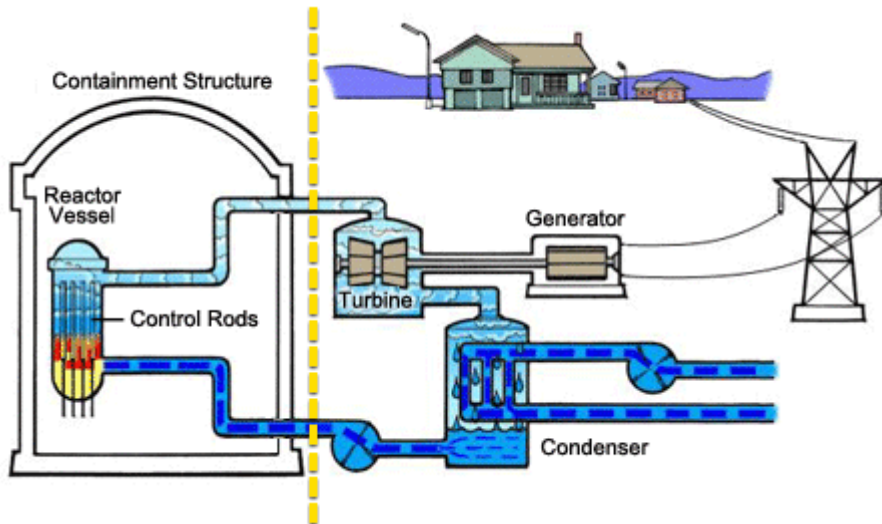

## Secondary System

As discussed earlier, the secondary system (SEC) of a nuclear power plant includes those systems that are outside the containment building. In a BWR, the secondary system includes the:

- Main steam system
- Condensate and feedwater system
- Cooling water system

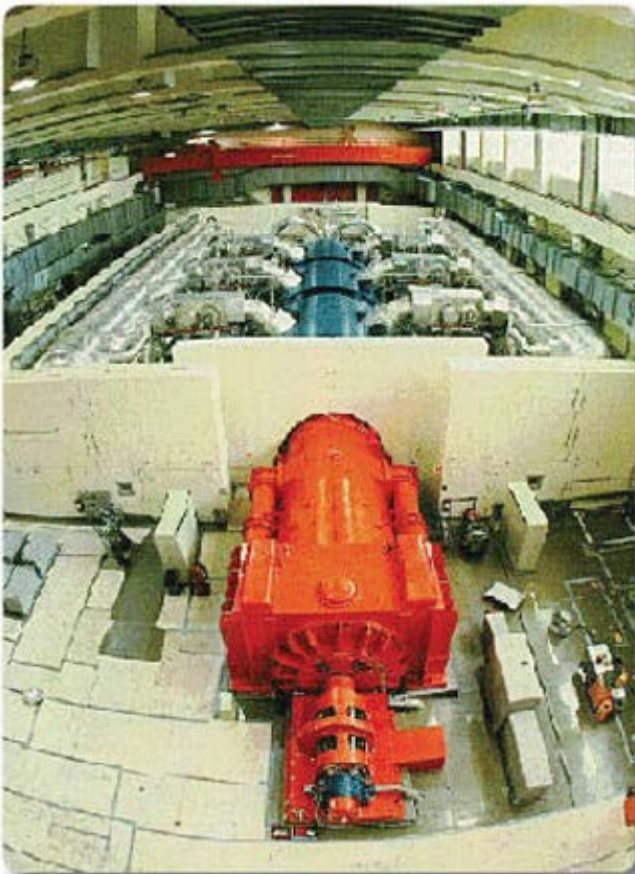

## SEC: Main Steam System

The main steam system directs steam from the reactor vessel to the:

- Turbine generator
- Bypass valves
- Reactor feed pump turbines
- Other selected balance of plant loads

It also directs steam to certain safety-related systems under abnormal conditions and provides overpressure protection for the reactor coolant pressure boundary.

Additionally, the main steam system also provides steam to places that need heating (i.e., feedwater heaters, condenser spargers, and others).

(Note in the graphic to the right: BWR turbine components are shielded for radiation. PWR turbines are not.)

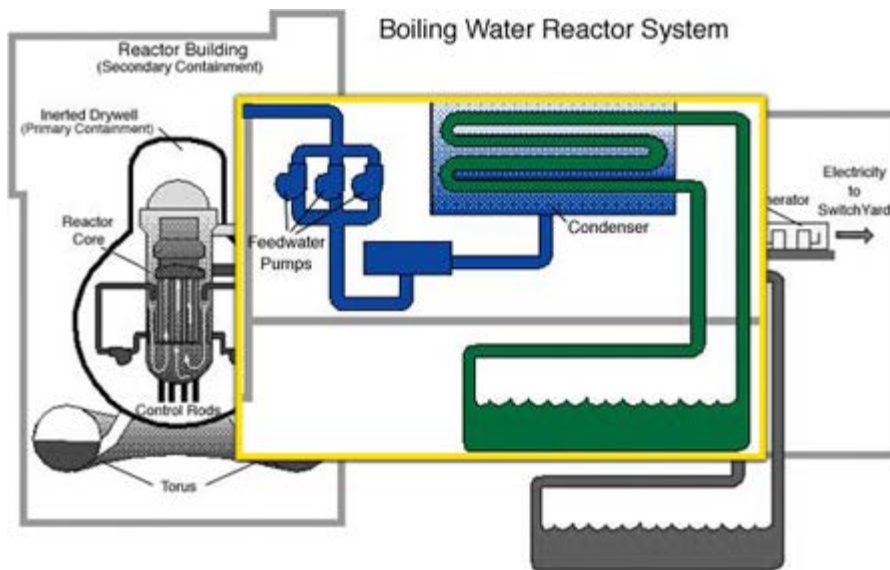

## SEC: Condensate & Feedwater System

The condensate and feedwater (FW) system performs numerous functions. The FW system:

- Condenses turbine exhaust and bypass steam
- Removes impurities
- Heats the feedwater
- Delivers the water back to the reactor vessel at the required rate

The FW system is integrated into other systems and links them together. The feedwater piping also provides a means to discharge water to the reactor vessel for the:

- Reactor water cleanup (RWCU) system
- Reactor core isolation cooling (RCIC) system
- High pressure coolant injection (HPCI) system

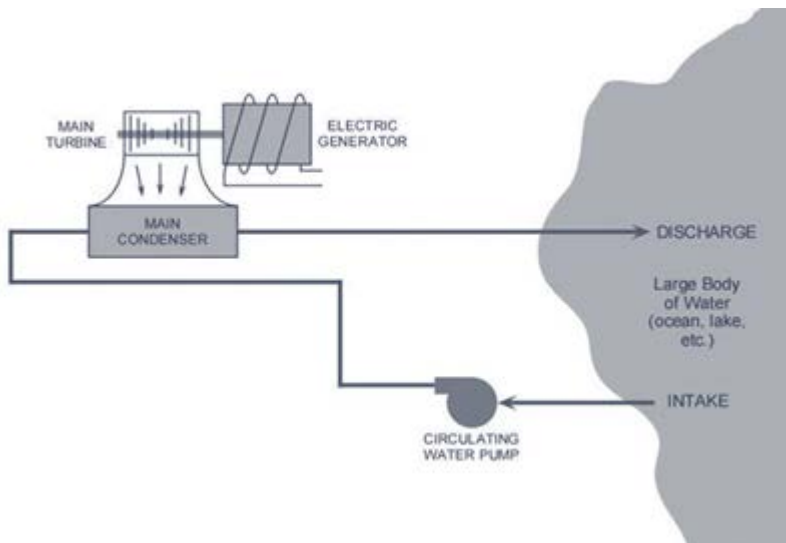

## SEC: Cooling Water System

The cooling water system interacts with the FW system, but is not a part of it. Recall that the FW system sends cool water to the reactor vessel and the other primary systems. The cooling water system pulls water from an external source (e.g., a river or ocean, or a cooling tower of some type on the site) to pass through the condenser and cool the steam that has been exhausted from the turbines and other secondary components.

The water in the cooling water system never mixes with the water in the condenser/secondary system. The piping for the cooling water system is separate from the piping of the secondary system. The cooling water condenses the steam back into feedwater in the condenser.



## Check Your Knowledge

### Which subsystems belong to which main systems?

Enter the number from the Answer Options in the corresponding field, then select Done.

Answer Options:

- 1 - Containment system (CONT)                      3 - Secondary System (SEC)  
 2 - Process instrumentation & control system (I&C)

- Main steam system
- Feedwater control system
- Standby gas treatment
- Reactor protection system (RPS)

-  Cooling water system

## Chapter Summary



### Key Points

- With a BWR:
  - The steam that turns the turbine comes in **direct contact** with the reactor core.
  - The water in the reactor core is kept at a relatively low pressure to allow it to boil and produce steam.
- Modern BWRs use forced circulation to increase control in maintaining a consistent temperature in the reactor core.
- The primary systems of a BWR are those inside the containment building. The secondary systems of a BWR are those outside of the containment building.
- The three primary functions of the systems in a BWR are:
  - Steam production
  - Electrical generation
  - Steam exhaust



### Key Points

- All BWR plants have the same basic functional systems. The subsystems of basic functional systems vary, based on the design and manufacturer. A functional system may include subsystems that are in the primary system, the secondary system, or both. The basic functional systems of a BWR include:
  - Reactor coolant system (RCS)
  - Emergency core cooling systems (ECCS)
  - Containment system (CONT)
  - Process instrumentation & control systems (I&C)
  - Secondary systems (SEC)



## Key Points

- The reactor coolant system (RCS) allows the operators to maintain and control optimal temperature in the reactor core. Subsystems of the RCS include:
  - Reactor vessel & core
  - Recirculation system
  - Reactor water cleanup
  - Standby liquid control
  - Control rods



## Key Points

- The emergency core cooling system (ECCS) provides core cooling under loss of coolant accident (LOCA) conditions to limit fuel cladding damage. Subsystems of the ECCS include:
  - Reactor core isolation cooling (RCIC)
  - High pressure coolant injection (HPCI)
  - Automatic depressurization system (ADS)
  - Low pressure coolant injection (LPCI)
  - Core spray (CS)



## Key Points for Containment

- Over the years, the BWR CONT evolved resulting in three designs. The major containment designs are the Mark I, Mark II, and Mark III.
- All three containment designs use the principle of pressure suppression for loss of coolant accidents and include the following subsystems:
  - Primary containment
  - Secondary containment
  - Standby gas treatment



## Key Points

- The process instrumentation and control (I&C) systems allow operators to monitor the reactor and support processes and make controlled corrections to the system. I&C subsystems include:
  - Reactor protection system (RPS)
  - Electro-hydraulic control (EHC)
  - Neutron monitoring
  - Feedwater control
- The secondary (SEC) systems are those that are outside of the containment building. In a BWR, the SEC systems includes the:
  - Main steam system
  - Condensate and feedwater system
  - Cooling water system



# Pressurized Water Reactor (PWR) Systems

## Chapter Introduction



## Chapter Overview

The other type of nuclear power plant in the United States (U.S.) is the [pressurized water reactor](#) (PWR). Approximately two-thirds of the commercial nuclear power plants in the U.S. are PWRs. There are currently five major PWR designs in use in the U.S.

Recall the key differences between a PWR and a boiling water reactor (BWR). With a PWR:

1. The steam that turns the turbine does **not** come in direct contact with the reactor core.
2. The water in the reactor core is kept at a very high pressure so that it does **not** boil in the core.

In this chapter, we will look at an overview of PWRs; consider the purposes of some of the major systems; and identify components associated with the major systems of a PWR.



## Objectives

After completing this chapter, you will be able to:

- Describe PWR systems, to include the purposes of major subsystems and components.

- Explain commercial electric power generation by a PWR nuclear power plant.
- Identify the key subsystems of a PWR system.
- Identify the purpose of the key subsystems of a PWR system.

**Estimated time to complete this chapter:**

40 minutes

## Overview of PWRs

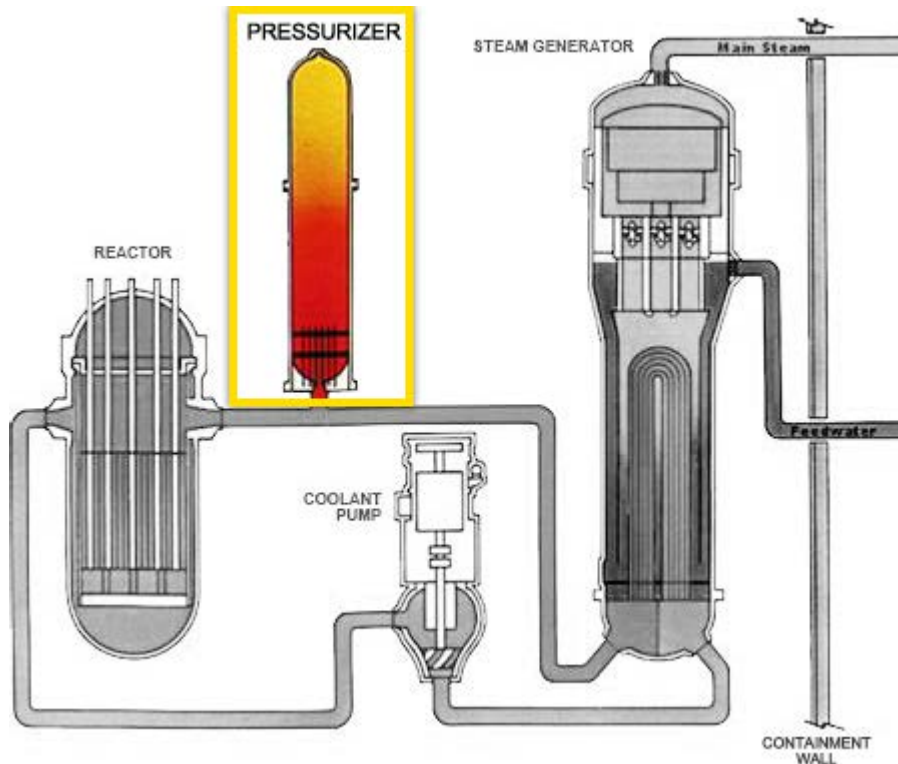

### Inclusion of a Pressurizer

Unlike BWRs, PWRs have not changed much in their basic design. PWRs have always used forced circulation, and include a [pressurizer](#) that keeps the coolant under high enough pressure to prevent boiling of coolant anywhere in the Reactor Coolant System (RCS).

The forced circulation is used to transfer the reactor heat from the core to the steam generators (SGs) rather than to control voids in the core. There are virtually no voids in a PWR core due to the high pressure.

The major item that operators use to control reactor power in a PWR is steam flow out of the SGs. Increased steam flow out of the SG cools off the reactor coolant more; the colder reactor coolant thermalizes/moderates neutrons better, so core power goes up.

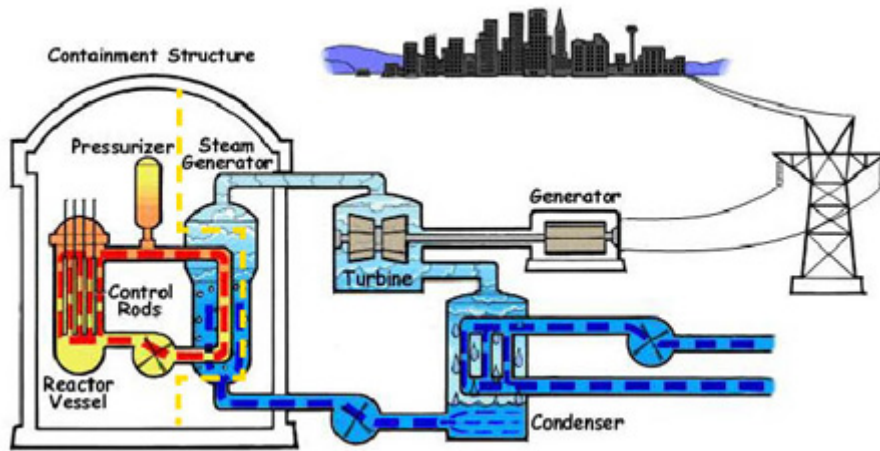

## Primary and Secondary Systems of a PWR

As with a BWR, a PWR nuclear power plant is also divided into primary and secondary systems. The dividing line between the two is a little more concrete in a PWR than in a BWR.

With a PWR, the [steam generator](#) (SG) provides the dividing line between the primary and secondary systems. More specifically, the tubes inside the SG constitute the line between primary and secondary. Primary coolant is inside the tubes; secondary water (incoming feedwater mixed with moisture stripped from the steam) is on the outside of the tubes.

The primary systems have direct contact with, or offer direct support to, the core. The secondary system provides support to the turbine, condenser, and feedwater to the SG.

The steam generator is the heat exchanger used in PWR designs to transfer heat from the primary (reactor coolant) system to the secondary (steam) system. Liquid from both the primary system and the secondary system pass through the steam generator, but they are isolated from each other.

The liquid and steam of the secondary system is kept in tubes. This design permits heat exchange with little or no contamination of the secondary system equipment.

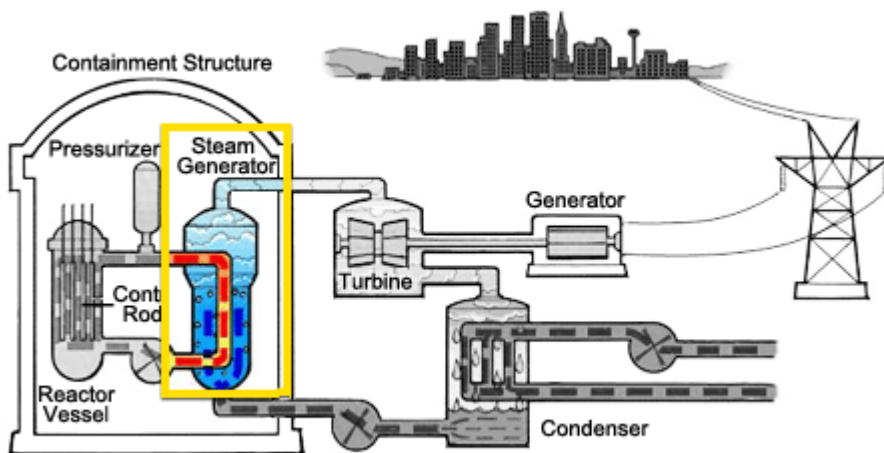
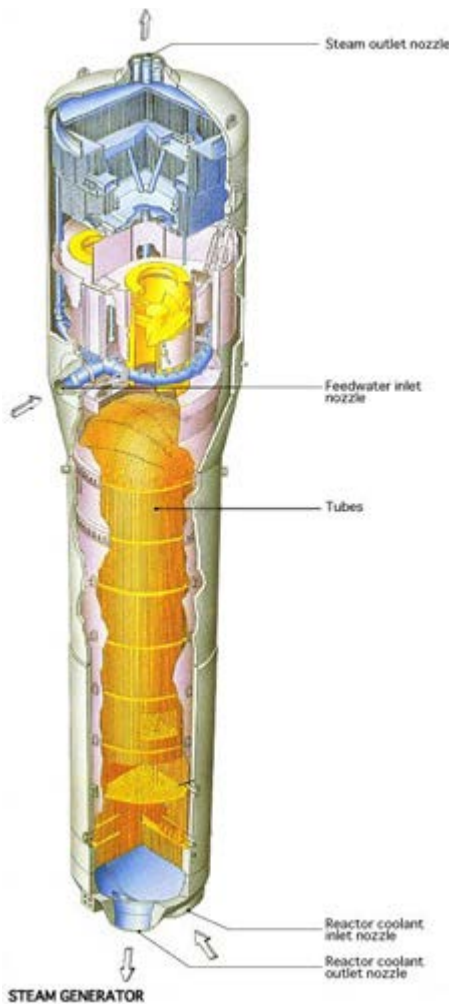

## Basic Functionality of a PWR: Steam Production

In a PWR, steam is produced in the SG, which is outside of the reactor vessel.

The [reactor coolant system](#) (RCS) is kept under very high pressure, more than 2,200 pounds per square inch. This high pressure prevents the primary coolant in the RCS from boiling, even at operating temperatures of more than 600°F. Contrast this with the BWR where reactor/steam pressure is only about 1,000 pounds per square inch, allowing the reactor coolant to boil within the core area.

Reactor coolant pumps (RCPs) push the hot coolant from the core through thousands of tubes in the SGs and back to the core for reheating. The heat of the reactor coolant inside these tubes (primary side) is transferred to the lower pressure feedwater, which is on the outside (secondary side) of the tubes. Since the SG secondary side pressure is relatively low (1,000 pounds), the feedwater boils to produce steam.

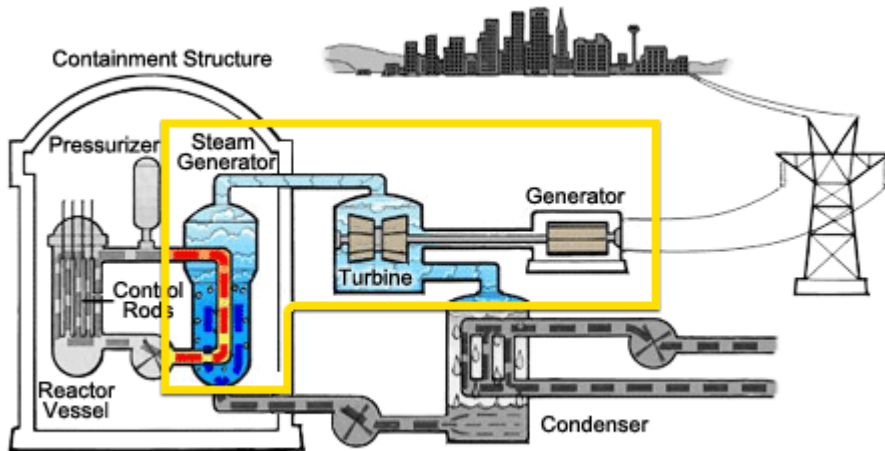

### Basic Functionality of a PWR: Electrical Generation

Remember that the SG, with the exception of the tubes, and the turbine are part of the secondary system.

In a PWR, the feedwater of the SG turns into steam to spin the turbine and generate electricity.

Other than the actual location of where the steam is produced, the generation of electricity in a PWR is almost exactly the same as with a BWR.

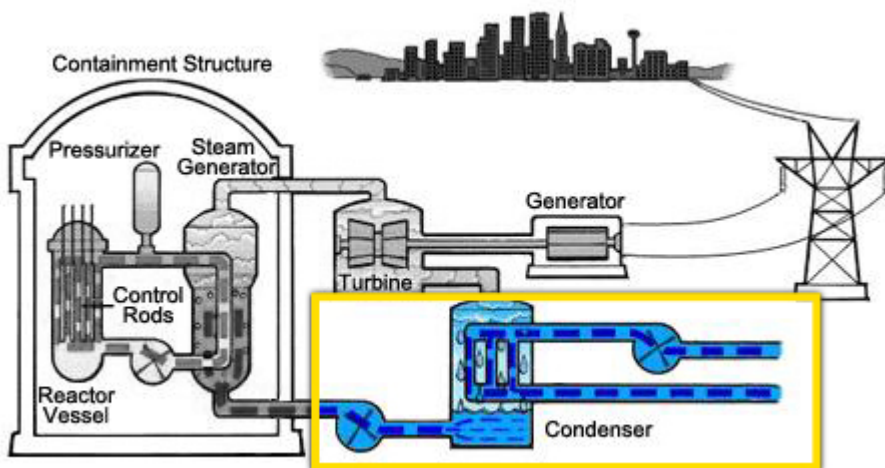

### Basic Functionality of a PWR: Exhaust Steam

The exhaust steam from the turbine goes to the condenser, is cooled, and then returns to the SG to start the cycle over again. Remember, this is different from the BWR where returning feedwater is sent directly back to the reactor core.

The PWR consists of two closed systems—unlike the single, closed system of the BWR. The advantage of this arrangement is that the steam for turning the turbine is never in direct contact with the core, so it is less radioactive. BWR turbines require shielding but PWR turbines do not.



## Check Your Knowledge

- **Which items can be used to explain how PWRs generate commercial electricity?**  
Select all that apply, then select Done.
  1. correct: The primary system is kept under very high pressure.
  2. The steam is generated within the reactor core.
  3. The operator increases or decreases the reactor power by manipulating the reactor pressure.
  4. correct: The steam that turns the turbine does **not** come in direct contact with the core.
  5. A PWR is a single, closed system.
- Correct. A PWR has two closed systems, with the primary system kept under very high pressure and the steam generated in the SGs of the secondary system. It is through the manipulation of the steam load that the operators can increase the power output of the plant.
- Incorrect. A PWR has two closed systems, with the primary system kept under very high pressure and the steam generated in the SGs of the secondary system. It is through the manipulation of the steam load that the operators can increase the power output of the plant.

## Functional Systems and Subsystems of a PWR



### Basic Functional Systems

Recall that all nuclear power plants have the same basic purpose—to create steam that turns the turbine and creates electricity in the electrical generator. As such, PWR nuclear plants have the same basic functional

systems as BWRs. Likewise, the subsystems of those systems vary, based on the design and/or manufacturer. A functional system may include subsystems that are in the primary system, the secondary system, or both. The basic functional systems of a PWR include:

- Reactor Coolant System (RCS)
- Emergency Core Cooling Systems (ECCS)
- Containment System (CONT)
- Process Instrumentation & Control Systems (I&C)
- Secondary Systems (SEC)

Let's take a look at each of these systems in more detail. We'll start with the RCS.

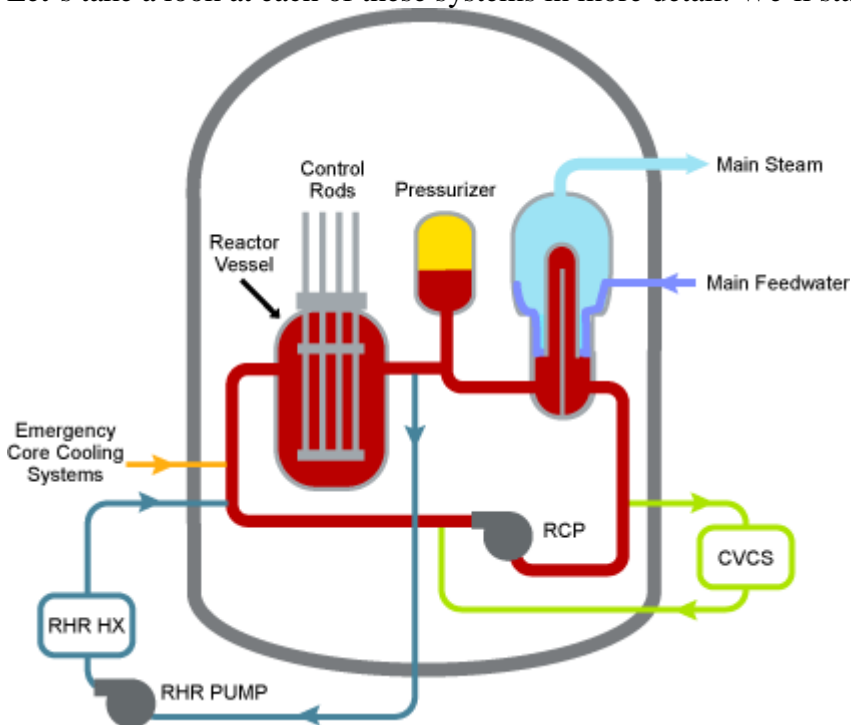

## Reactor Coolant System (RCS)

As with a BWR, the RCS allows the operators to maintain and control optimal temperature in the reactor core. Subsystems of the RCS include:

- Reactor Vessel & Core
- Pressurizer (PZR)
- Reactor Coolant Pump (RCP)
- Chemical & Volume Control (CVCS)
- Control Rods and Control Rod Drive System
- Residual Heat Removal (RHR)

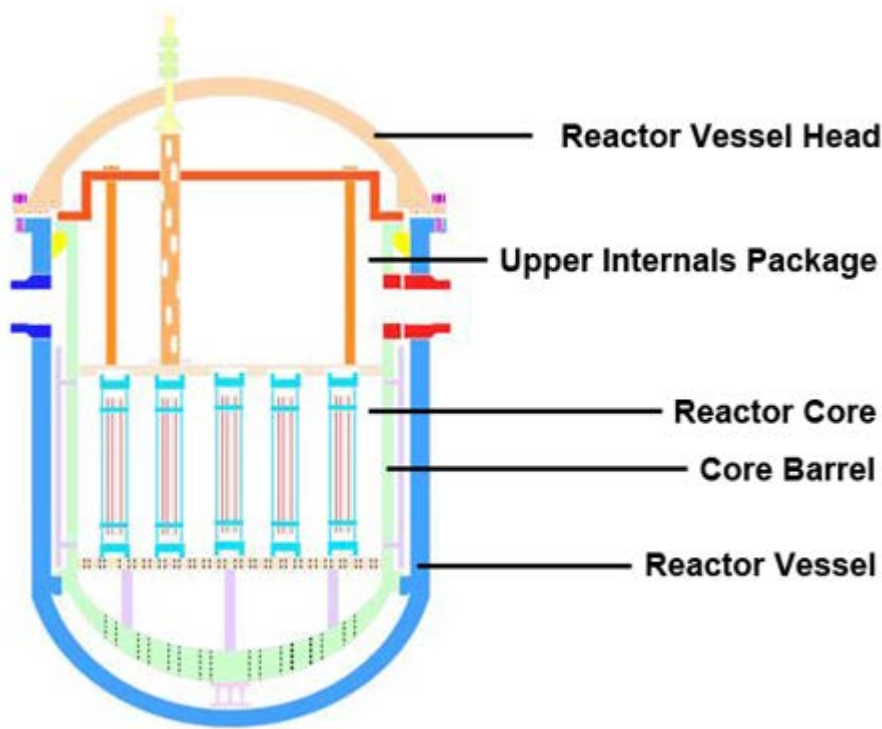

### RCS: Reactor Vessel and Core

The reactor core, and all the associated support and alignment devices, is housed within the reactor vessel. The major components are the:

- [Reactor vessel and vessel head](#)
- [Core barrel](#)
- [Reactor core](#)
- [Upper internals package](#)



The reactor vessel is a cylindrical vessel with a hemispherical bottom head and a removable hemispherical top head. The top head is removable to allow for the refueling of the reactor. There will be one inlet (or cold leg) nozzle and one outlet (or hot leg) nozzle for each reactor coolant system loop. The reactor vessel is constructed



of a manganese molybdenum steel, and all surfaces that come into contact with reactor coolant are clad with stainless steel to increase corrosion resistance.



The core barrel slides down inside of the reactor vessel and houses the fuel. Toward the bottom of the core barrel, there is a lower core support plate on which the fuel assemblies sit. The core barrel and all of the lower internals actually hang inside the reactor vessel from the internals support ledge. On the outside of the core barrel will be irradiation specimen holders in which samples of the material used to manufacture the vessel will be placed. At periodic time intervals, some of these samples will be removed and tested to see how the radiation from the fuel has affected the strength of the material.



The upper internals package sits on top of the fuel. It contains the guide columns to guide the control rods when they are pulled from the fuel. The upper internals package prevents the core from trying to move up during operation due to the force from the coolant flowing through the assemblies.

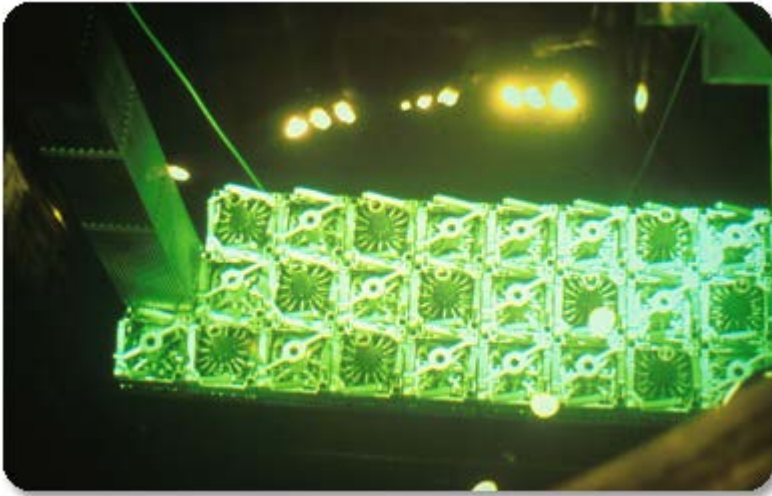

The reactor core includes the fuel assemblies and control rods.

### **RCS: Reactor Vessel and Core Flow Through**

Move the tab along the slider bar to learn about the flow path of the reactor coolant.

For non-sighted users, please use these skip links to access the items on the slider.

- [reactor coolant](#)
- [coolant enters the reactor vessel](#)
- [core barrel](#)
- [bottom of the reactor vessel](#)
- [fuel assemblies](#)
- [upper internals](#)

The reactor coolant (water) enters from the cold leg and leaves via the hot leg.

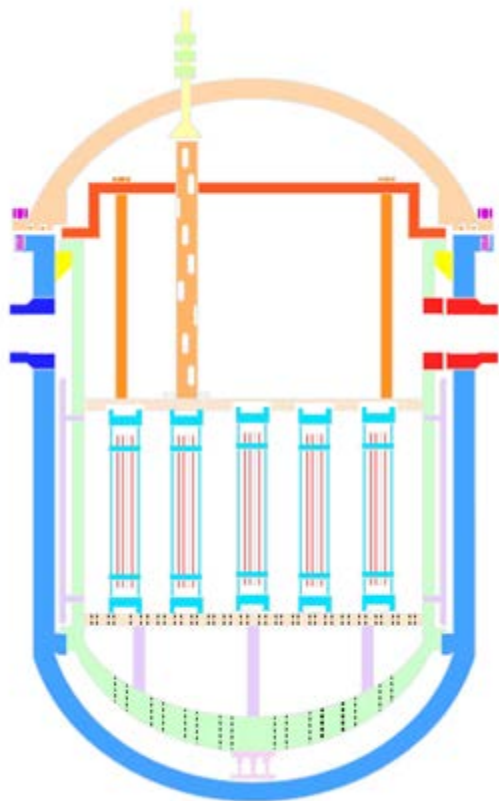

The coolant enters the reactor vessel at the inlet nozzle and hits against the core barrel.

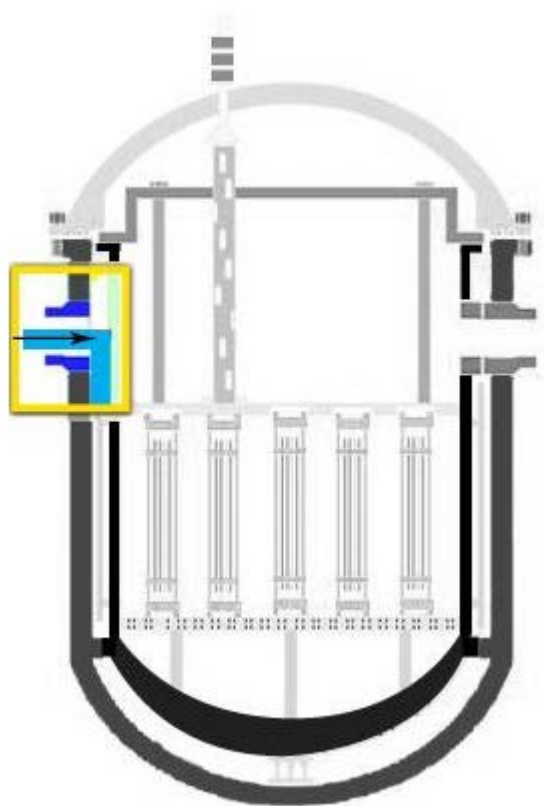

The core barrel forces the water to flow downward in the space between the reactor vessel wall and the core barrel.

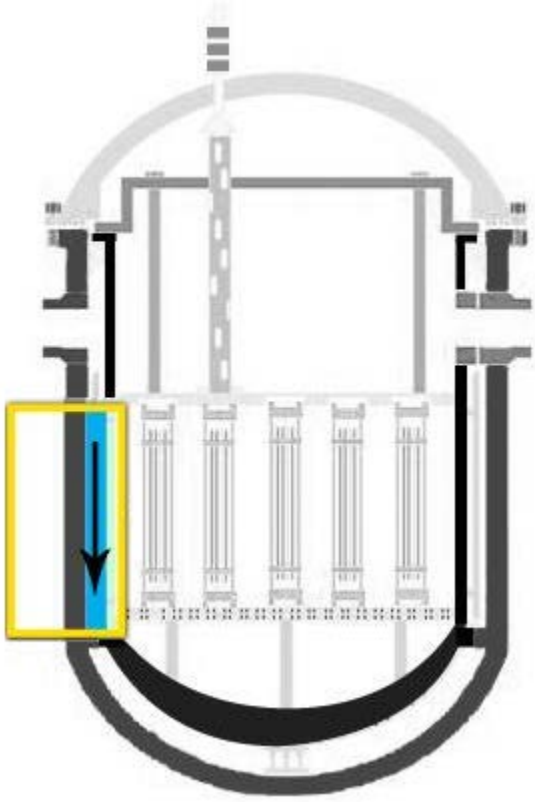

After reaching the bottom of the reactor vessel, the flow is turned upward to pass through the fuel assemblies.

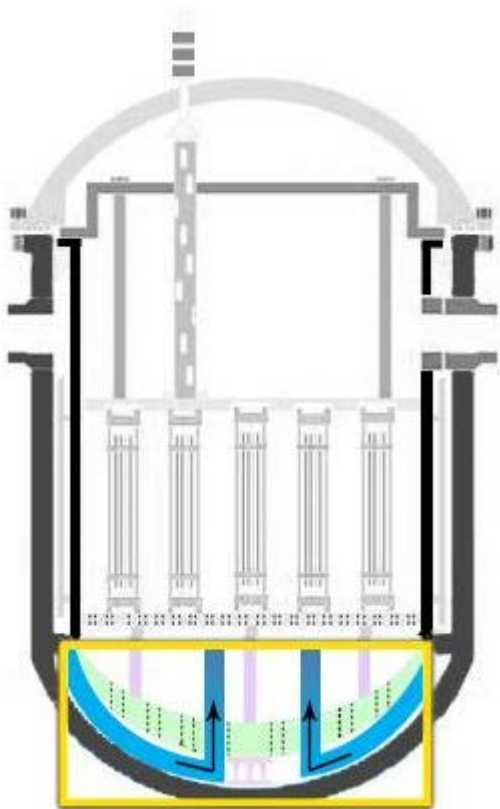

The coolant flows all around and through the fuel assemblies, removing the heat produced by the fission process.

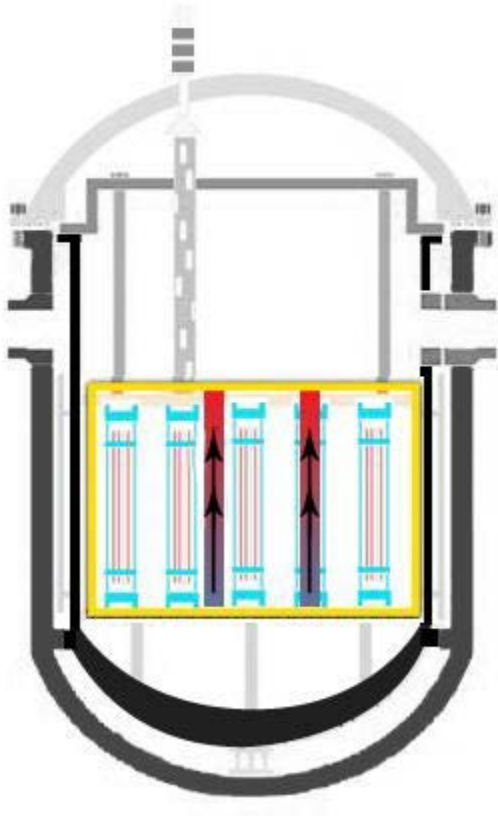

The now hotter water enters the upper internals region, where it is routed out of the outlet nozzle and moves on to the SG.

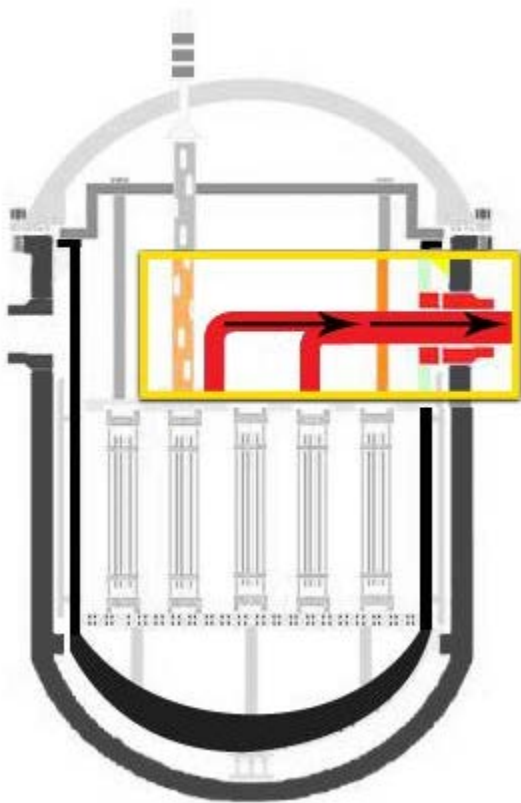

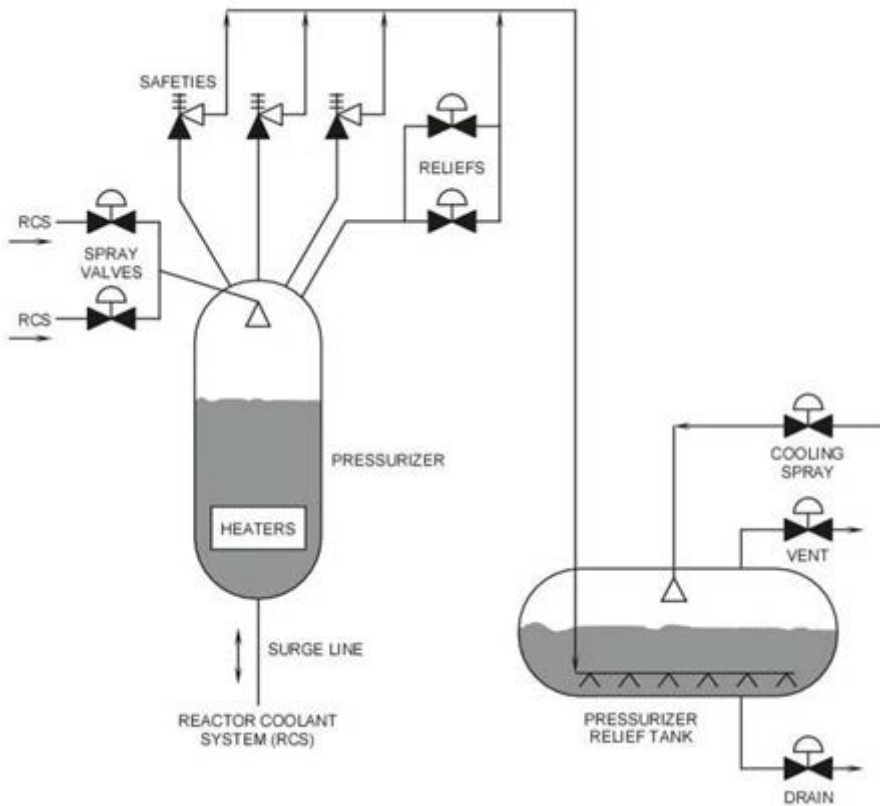

## RCS: Pressurizer (PZR)

The PZR provides a means of controlling the system pressure and reactor coolant water level. Pressure is controlled by the use of electrical heaters, pressurizer spray, power-operated relief valves, and code safety valves. Level is controlled by the charging and letdown system (CVCS).

The PZR operates with about a 50/50 mix of steam and water. Pressure deviation is normally associated with a change in the temperature of the RCS. If the temperature starts to increase, the density of the reactor coolant decreases and the water expands. Since the PZR is connected to the RCS via the surge line, the water expands into the PZR. This causes the steam in the top of the PZR to be compressed and pressure increases. The opposite effect occurs if the RCS temperature decreases. The water becomes denser and shrinks. The level in the PZR decreases, which causes a pressure decrease. For a pressure increase or decrease outside of a programmed band, the PZR components operate to bring pressure back to normal.

For example, if pressure increases above the desired set point, the spray line sprays relatively cold water from the discharge of the RCP (cold leg) into the steam space. The cold water condenses the steam into water and reduces pressure (steam takes up about six times more space than the same mass of water). If pressure continues to increase, the power operated relief valves open and dump steam to the pressurizer relief tank (PRT). If this does not relieve the pressure, the safety valves lift and discharge to the PRT. If pressure starts to decrease, the electrical heaters are energized to boil more water into steam, and therefore increase pressure. If pressure continues to decrease, and reaches a predetermined set point, the reactor protection system trips the reactor.

The PRT contains water with a nitrogen atmosphere. The water condenses any steam discharged by the safety or relief valves. Since the RCS contains hydrogen, the nitrogen atmosphere prevents the hydrogen from creating an explosive mixture.

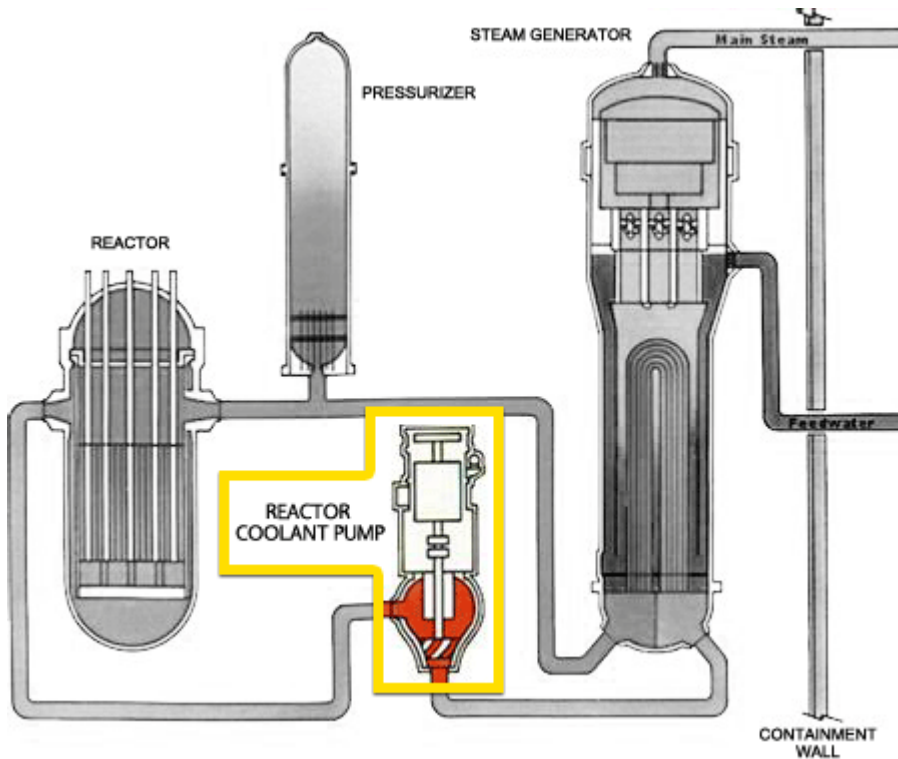

### RCS: Reactor Coolant Pumps (RCPs)

PWR RCPs are very large, centrifugal pumps that push the reactor coolant through the core and SG tubes.

The discharge (outlet) of the RCP is sent through an RCS pipe called the cold leg. The coolant enters the reactor vessel and is then directed through the core to pick up heat. The coolant exits the vessel through the hot leg and is sent to the SG tubes. After giving up its heat, the coolant leaves the SG and goes back to the suction (inlet) of the RCP, where the cycle starts over again.

As stated, the RCPs are very large pumps. A [typical RCP](#) is characterized as:

- Upwards of 10,000 Horsepower (for comparison, a souped-up Mustang GT might produce 300 to 400 hundred horsepower)
- High voltage (6 to 13 thousand volts)
- Weighs 40 to 50 tons
- Produces around 100,000 gallons per minute of flow

Due to the pump design and RCS high pressure, the pumps have special seals on their shafts to keep primary water leakage low. These seal packages have special cooling and lubricating systems. Some new PWR plant designs are moving to specially designed RCPs that will not require seals.

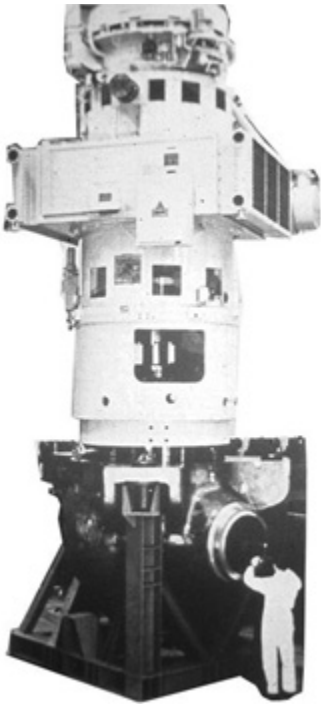

A technician prepping an RCP for installation.

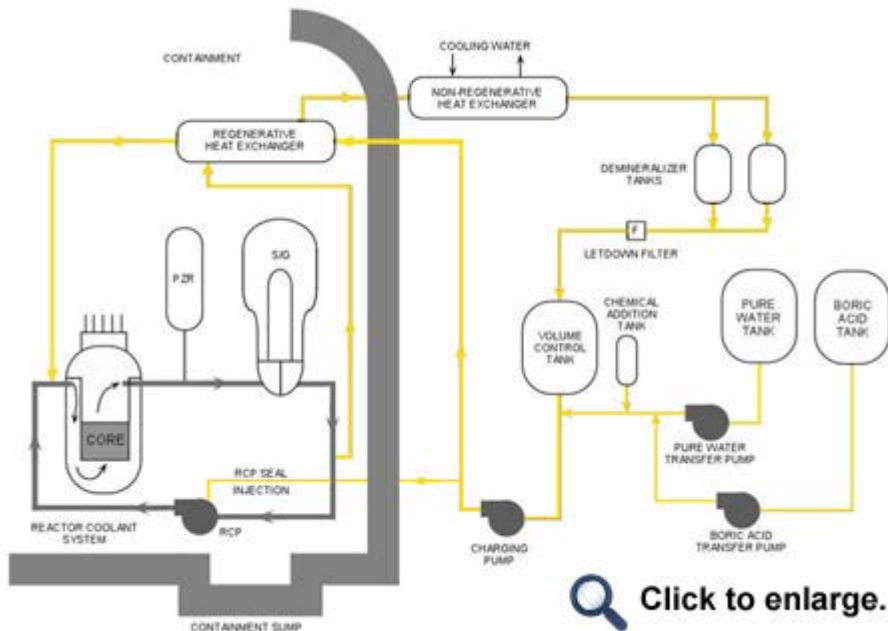

## RCS: Chemical & Volume Control System (CVCS)

The CVCS is a major support system for the RCS. Some of its functions are:

- Purification of the RCS coolant using filters and ion exchangers/demineralizers
- Control of boron added to the coolant for neutron absorption
- Controlling the volume of water in the RCS, hence controlling the water level in the PZR

PWRs routinely allow a small amount (75 gallons per minute) of RCS to be routed out of the primary into the CVCS system. This letdown is depressurized and cooled down, then sent to the cleanup system and collected for re-use in a Volume Control Tank (VCT).



Operators can add various chemicals to the coolant in the RCS upstream of the charging pumps, and then send the coolant back into the RCS. Chemicals such as hydrogen gas for oxygen scavenging, boric acid for neutron absorption, and lithium hydroxide for pH control are routinely used.

Some of this clean and relatively cool charging water is sent to the RCP seals for cooling and lubrication.

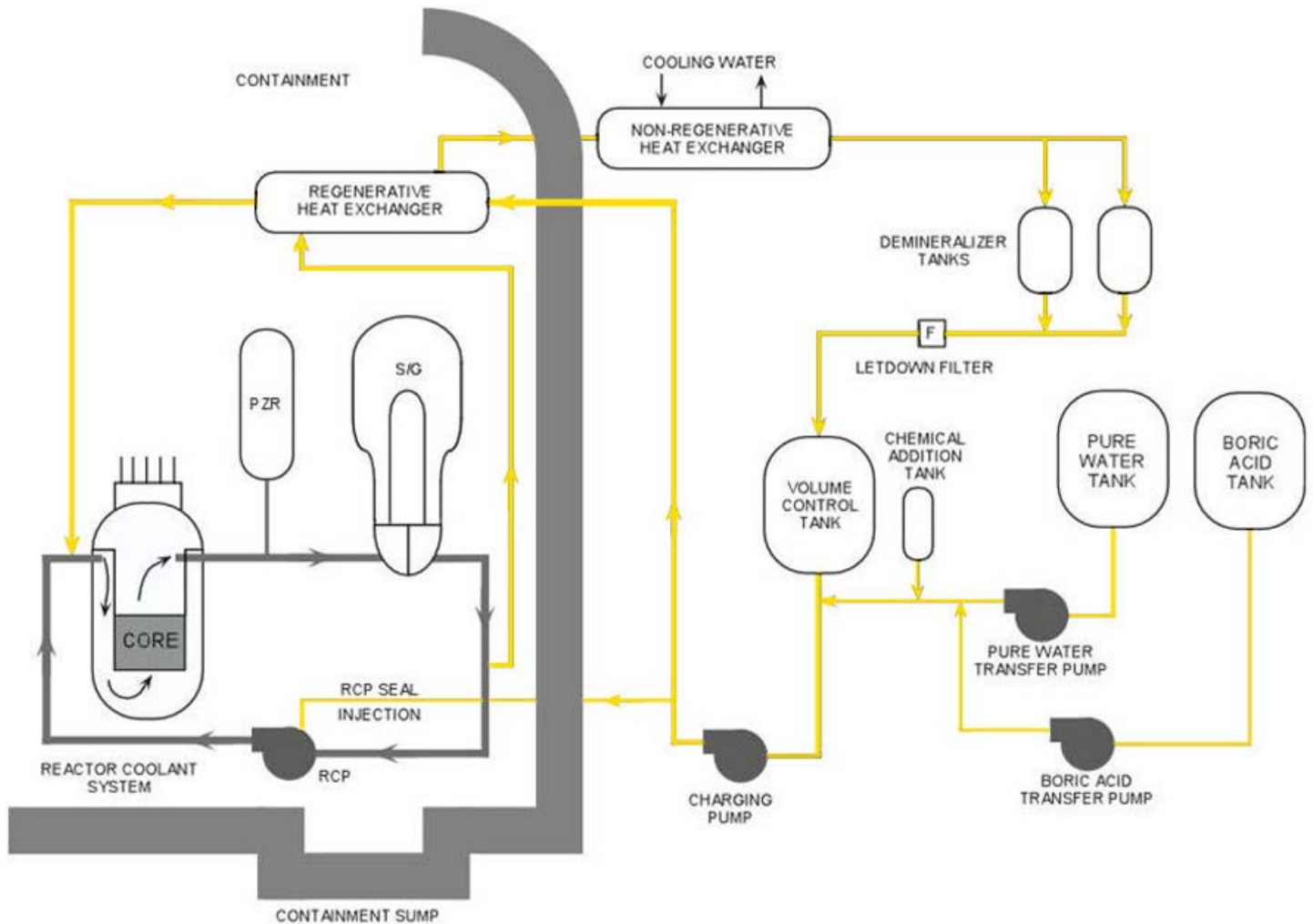

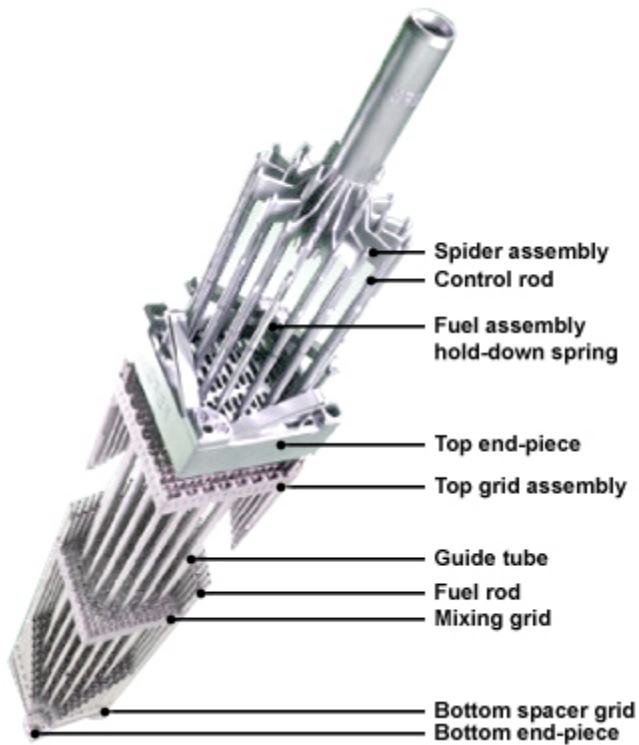

## RCS: Control Rods

Recall that control rods are neutron [poisons](#). These strong neutron absorbers are connected to a cluster assembly that can be moved in and out of the core to control the nuclear fission process. PWR control rods consist of a silver-indium-cadmium or a boron carbide mixture sealed inside stainless steel tubes.

In a PWR, the control rod fingers are attached to a spider assembly. The spider provides the connection between the control rod and the control rod extension shaft. The extension shaft extends up through the vessel head where the control rod drive system can move the shaft and rod.

Rod Cluster Control Assembly (RCCA) is the formal name for grouped control rods and the spider. (These are generally Westinghouse terms; Babcock & Wilcox and Combustion Engineering use similar components with different terminologies.)

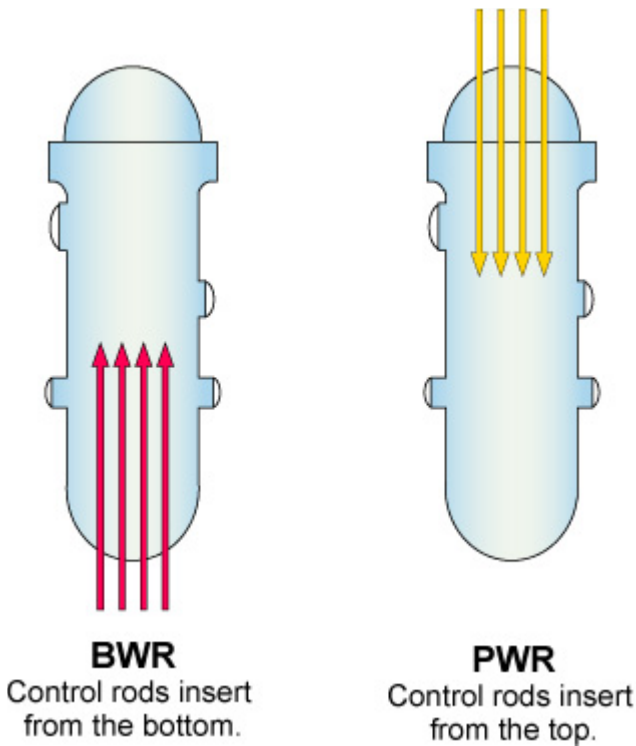

### RCS: Control Rod Drive System

PWR control rod drive systems are very different from those of BWR plants. PWR rod drive systems penetrate the core through the upper reactor vessel head. Since PWR system pressure is so high, these rod drive systems must be inside the pressure boundary of the RCS. This requires a special method to actually move the rods.

Since there is no physical connection between the control rod and its drive system, the PWR rod control system uses magnetism to create the movement. Devices known as grippers are inside the RCS boundary and can be controlled or moved by magnetic fields. The magnetic fields are produced **outside** of the RCS boundary by the rod control system drive. If a plant trip is required, the magnetic fields are de-energized; the grippers let go of the control rod extension shaft; and the rods drop into the core, shutting down the fission process.

### RCS: Residual Heat Removal

Just as with BWR plants, PWR fuel will produce significant amounts of decay heat even after PWRs are shut down. This heat must be removed to keep the core safe.

Normally, PWRs use the SG to cool the core. The operator ‘dumps’ steam from the SG to the condenser via turbine bypass valves. However, once the RCS cools down far enough, there is insufficient heat to produce much steam.

At this point, operators use the low pressure, high flow pumps (RHR) from the ECCS systems to remove the decay heat. Once primary pressure is reduced to less than about 200 pounds per square inch, operators realign the lower pressure ECCS subsystem to remove water from a RCS hot leg; pump it through coolers cooled by safety-related cooling systems; and then return it to the RCS via piping connected to the cold legs.

Flow through the core is maintained in its normal direction, and the decay heat can be removed to keep the core cool. The decay heat is ultimately directed out to the environment through the safety related cooling system.

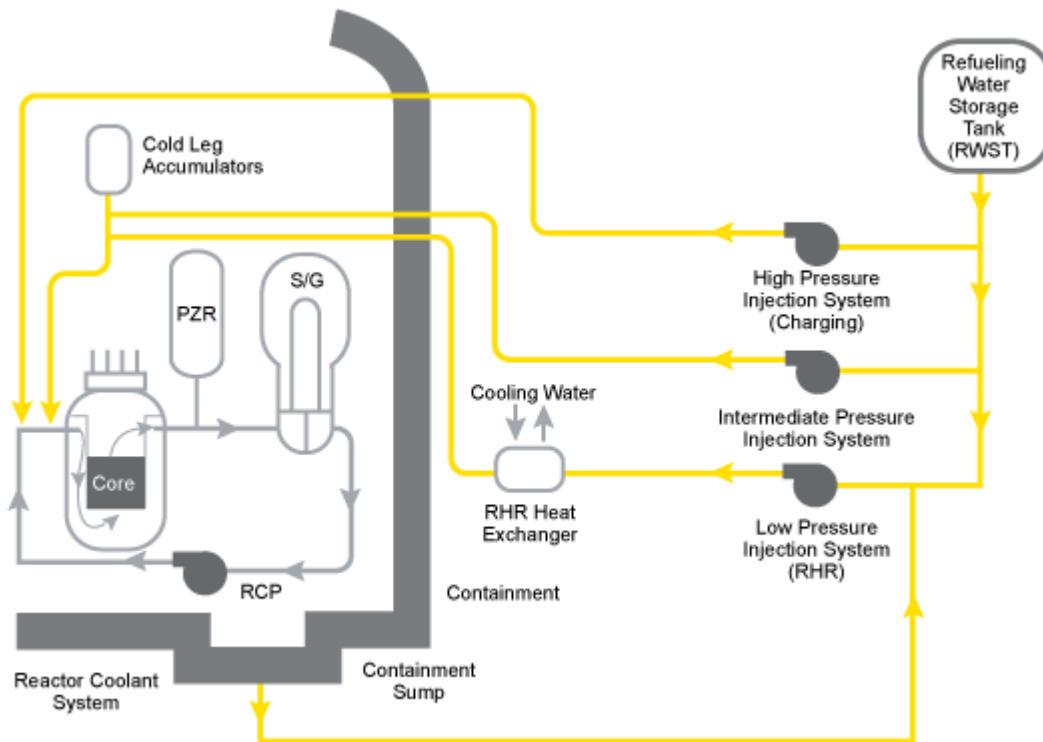

## Emergency Core Cooling System (ECCS)

The ECCS of a PWR is much like a BWR in that its main function is to provide cooling to the core in an emergency. However, due to design differences, a PWR must also ensure that the core remains subcritical in case of a steam leak (PWRs rely on boron, in addition to control rods, to stop the fission process in certain accidents). The ECCS subsystems accomplish this by injecting highly borated water into the core. Recall from an earlier chapter that boron is an extreme poison to the fission process.

PWR ECCS subsystems are generally comprised of:

- High Pressure Coolant Injection (HPCI) Pumps
- Intermediate or Medium Pressure Coolant Injection (MPCI) Pumps
- Low Pressure Coolant Injection (LPCI) Pumps, also known as RHR pumps (dual duty)
- Passive Accumulators (ACC)
- Containment Spray (CS) Pumps

These systems are generally aligned to automatically start in certain emergencies, but they will not inject into the RCS unless pressure drops sufficiently down to their operating point.

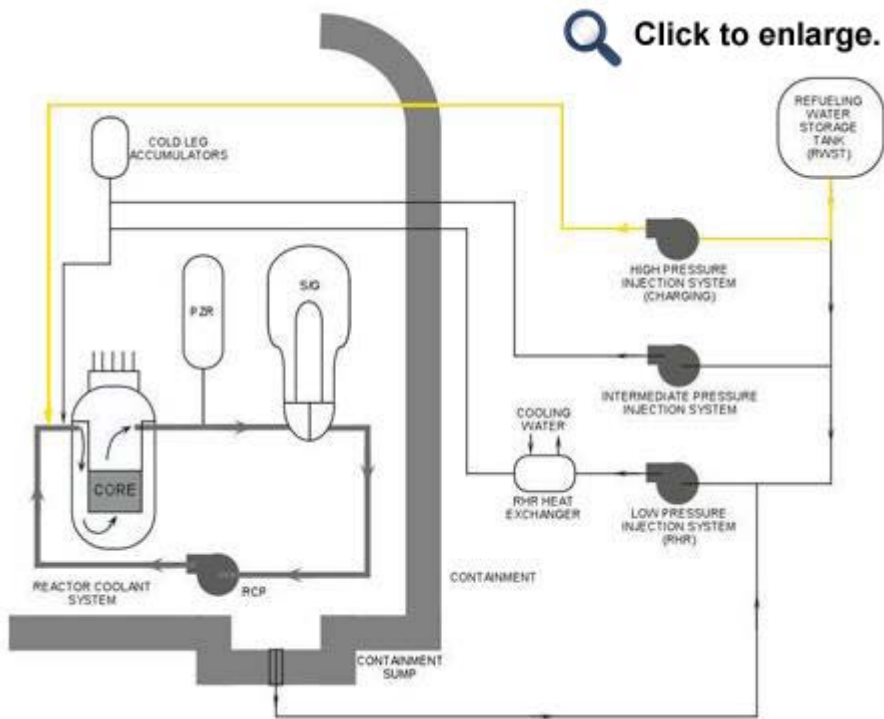

### ECCS: High Pressure Coolant Injection (HPCI)

The HPCI system uses the pumps in the chemical and volume control system. After receipt of an emergency actuation signal, the system automatically realigns to take water from the refueling water storage tank (RWST) and pump it into the RCS.

The HPCI system provides water to the core during emergencies in which RCS pressure remains relatively high (such as small breaks in the RCS, steam break accidents, and leaks of reactor coolant through an SG tube to the secondary side). Most HPCI systems, though, are lower flow systems.

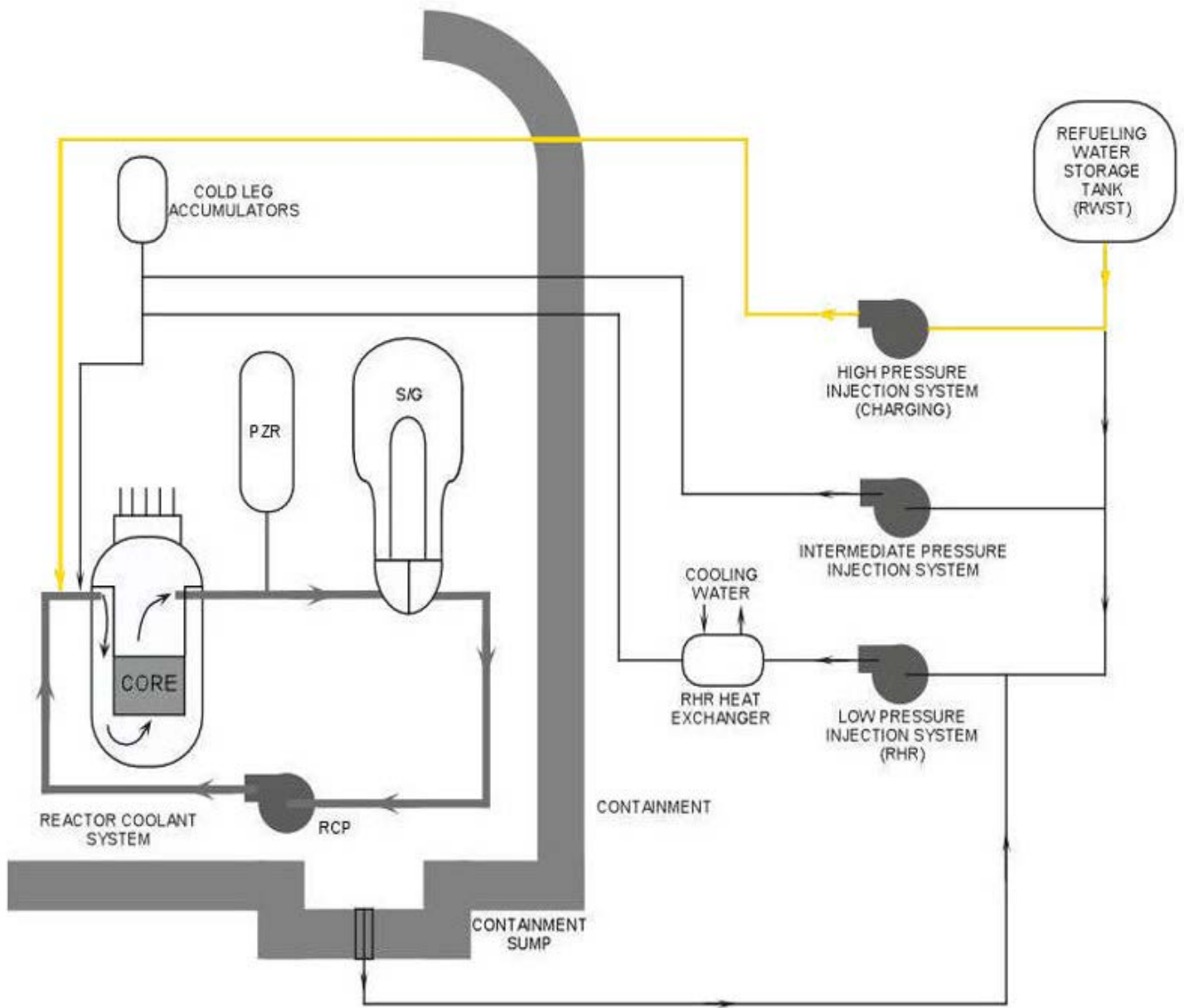

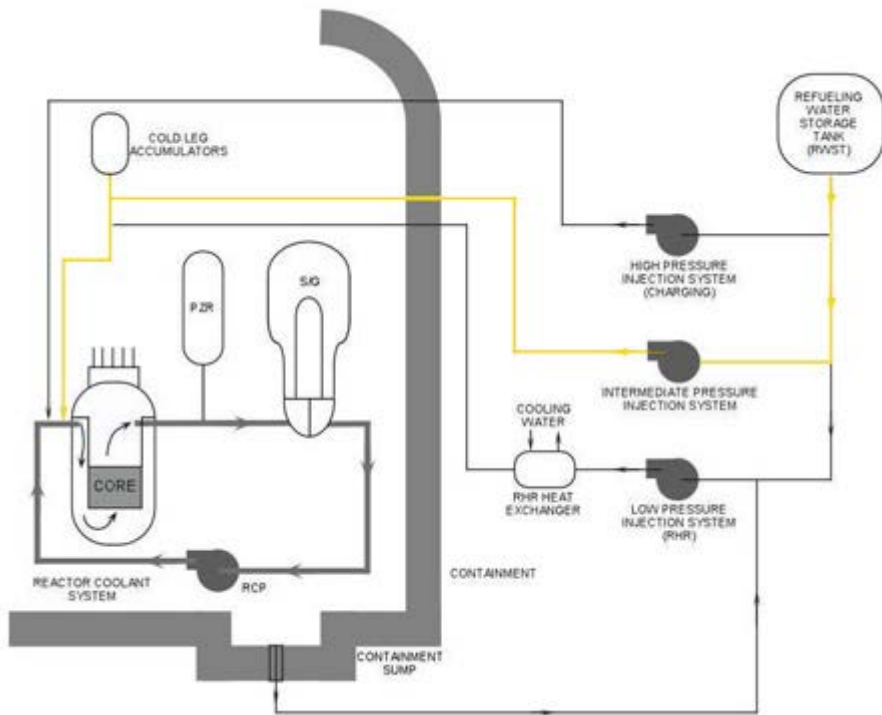

## ECCS: Intermediate Pressure Injection System

The intermediate pressure injection system is also designed for emergencies in which the RCS pressure stays relatively high, such as small to intermediate size primary breaks. After an emergency start signal, the pumps take water from the RWST and pump it into the RCS.

Because PWR plants operate at high primary pressures, they use pumps to inject water into the RCS in an accident. These pumps require electricity; if electric power is lost, a different method of injecting water is required.

The intermediate injection pumps will produce more flow than the high pressure ones, but they will not pump against as high a pressure.

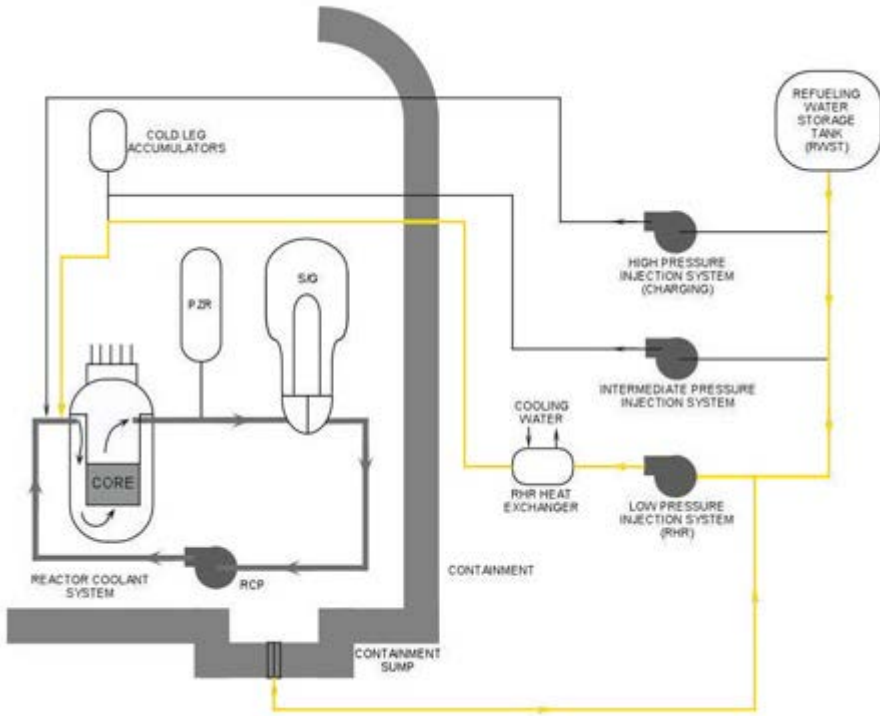

### ECCS: Low Pressure Injection System

The low pressure injection system is commonly referred to as the residual heat removal, or RHR, system. During power operations, it will be lined up to automatically inject water from the RWST into the RCS during large breaks that cause a very low RCS pressure.

In addition, the RHR system has a feature that allows it to take water from the containment sump, pump it through the RHR system heat exchanger for cooling, and then send the cooled water back to the reactor for core cooling. This method of cooling would be used when the RWST empties after a large primary system break. It is called the long-term core cooling or recirculation mode.

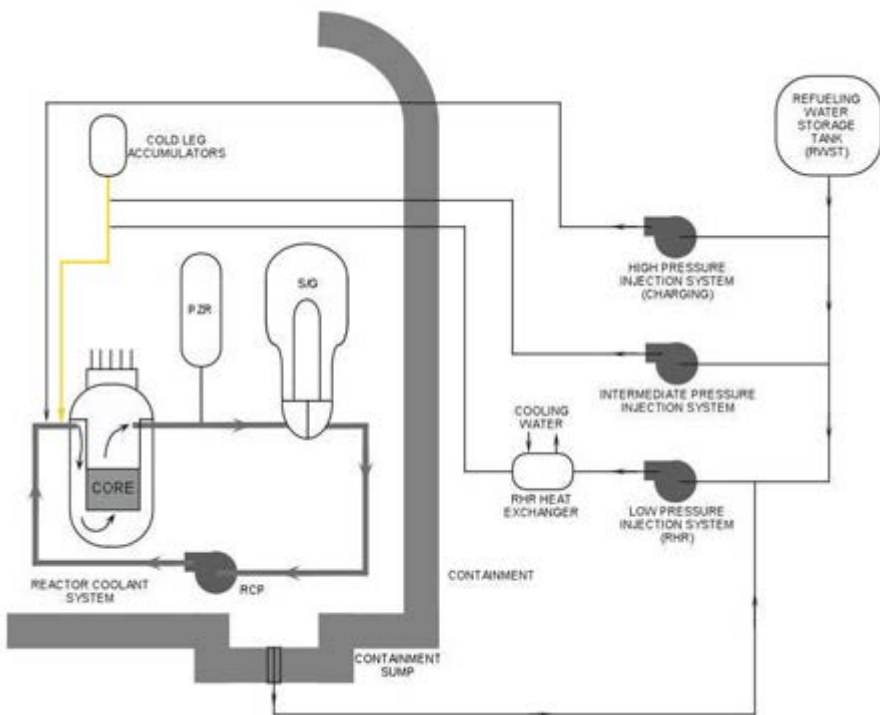



## ECCS: Passive Accumulators (ACC)

The cold leg accumulators, also called passive accumulators, do not require electrical power to operate. These tanks provide borated water to the RCS during emergencies in which the RCS pressure drops very rapidly, such as with large primary breaks.

The ACCs contain large amounts of borated water with a pressurized nitrogen gas bubble in the top. If the primary pressure of the RCS drops lower than the nitrogen gas pressure in the accumulators, then the nitrogen forces the borated water out of the tank and into the RCS and core.

Since PWR plants normally operate at high primary pressures, they use electric pumps to inject water into the RCS in an accident. The ACCs provide a method of injecting water if electric power is lost.

Use of ACCs is not a permanent solution to a large primary break. PWR plants have emergency diesel generators for times where electric power is lost. The ACCs allow core cooling during the 10 to 30 seconds it takes for the diesel generators to start and provide power to ECCS pumps.

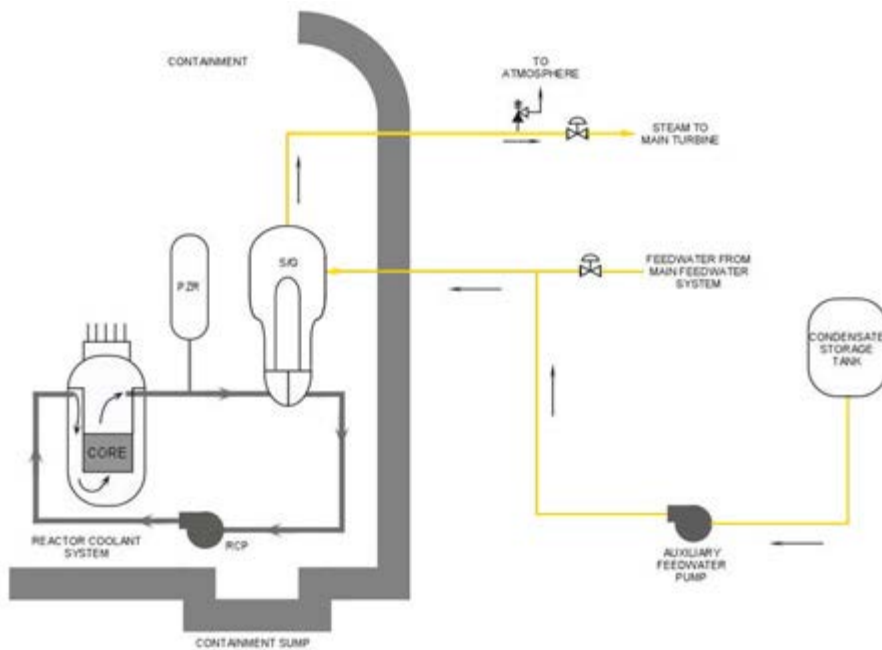

## Auxiliary Feedwater (AFW) System

In a PWR, the preferred method of removing reactor core heat is by taking steam out of the SG. In order to ensure that steam can be produced, there must be a reliable way of getting feedwater into the SG. The AFW system is a safety-related system that can inject clean and cool feedwater into the SGs in an emergency, ensuring a viable method of removing core heat.

While the AFW system is not a true ECCS system, it is the preferred method for the operator to use to add feedwater to the SG in order to remove core heat in an emergency.

Plants usually have a large tank of ultra-pure water available for the AFW system. The AFW system draws water from the tank and adds it to the SG. However, for plants that do not have the safety-related condensate storage tanks, they will fill the SG from the safety related service water system. The operators then send the steam to the condenser for reclamation, or in an emergency the steam is sent out the roof via atmospheric dump valves, thus removing the decay heat.



## Check Your Knowledge

### Which subsystems belong to which main systems?

Enter the number from the Answer Options in the corresponding field, then select Done.

Answer Options:

1 - Reactor Coolant System (RCS)    2 - Emergency Core Cooling System (ECCS)

- Reactor Coolant Pump (RCP)
- Control Rods and Control Rod Drive System
- Intermediate or Medium Pressure Coolant Injection (MPCI) Pumps
- Chemical & Volume Control (CVCS)
- Passive Accumulators (ACC)



## Containment System (CONT)

PWR and BWR plants must have a [containment](#) building. However, because of the high pressure of the PWR primary and the relatively larger quantity of water in systems inside the containment, the PWR containment building must be stronger than that of a BWR.

PWR containment buildings are generally very large. Sometimes they contain over 1 million cubic feet of internal volume. The walls are reinforced concrete more than 3 feet thick. They are reinforced with metal lattices of 2 to 3 inch rebar. Some PWR containment designs are a little different: with sub-atmospheric pressures (slight vacuum) or with ice condensers inside (steam from a leak contacts ice with boron to reduce heat and pressure).

PWR containments also have tendons running through them. Containment tendons are very large, metal-wire bundles almost 6 inches thick that run through the walls. These tendons are stretched using special hydraulic tensioners so that the tendon squeezes the walls of the containment inward. These pre-tensioned cables allow the containment to withstand much higher internal pressures than one made with only rebar.

Imagine how much more pressure a can of Coke can withstand if you wrap something around it that is squeezing the walls **inward**.

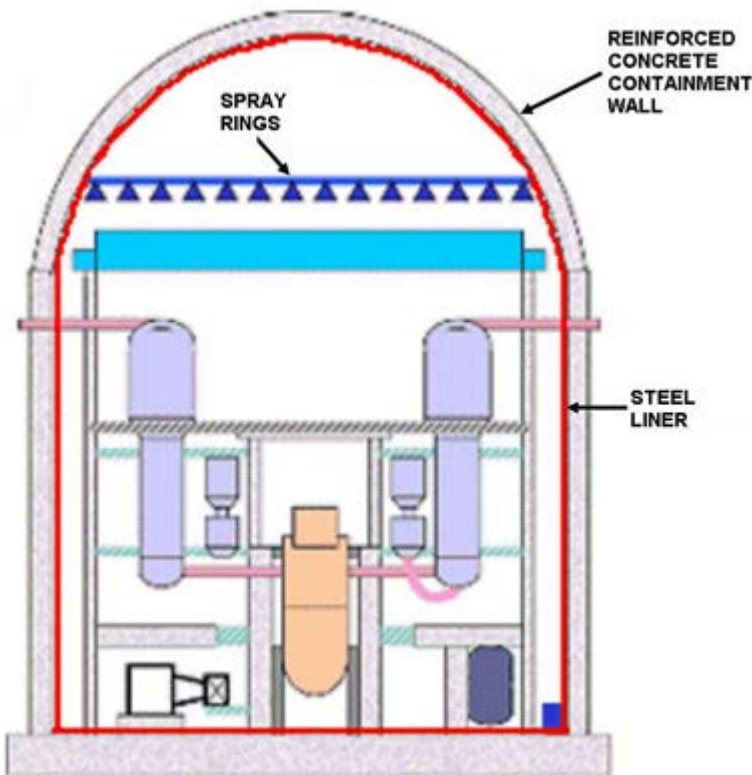

## CONTAINMENT

PWR containments are designed to withstand the pressures and temperatures that would accompany release of a high energy fluid (i.e., the primary coolant, steam, or feedwater). However, the exposure to high temperature and pressure over a long period of time could degrade the concrete.

If a break occurred in the primary system, the released coolant could contain [fission products](#). If the concrete developed any cracks, the high pressure in the containment would force the radioactive material through the relatively porous concrete containment wall, and into the environment.

To limit leakage following an accident, a steel liner covers the **inside** surface of the containment building. This liner acts as a vapor- and liquid-proof membrane to prevent any gas from escaping through cracks that may develop in the concrete. Some newer design PWR containments have a space, or annulus between this liner and the concrete wall. In this design, the liner provides both the pressure and leakage boundary, while the concrete shell provides protection from various external hazards.



## Process Instrumentation & Control (I&C) Systems

PWRs also include extensive process I&C systems. As in a BWR, the process I&C systems allow the operators to effectively monitor the reactor processes and all support processes, and make corrections to the system when needed. Many of the systems are similar to those in the BWR, but there are a few differences.

I&C subsystems include:

- [Reactor protection system \(RPS\)](#)
- [Neutron monitoring](#)
- [SG water level control](#)
- [Pressurizer pressure and level control](#)

The purposes of the Reactor Protection System (RPS) are to automatically initiate a reactor scram to protect the fuel cladding, to preserve the integrity of the reactor coolant system, and to minimize the energy which must be absorbed following a loss of coolant accident (keep the containment intact).

Multiple, redundant systems monitor key plant parameters and will quickly shut the reactor down if conditions deteriorate. The system requires more than one of the same parameters to be bad in order to prevent a failed instrument from causing a scram.

The purposes of the Neutron Monitoring System (NMS) are to monitor reactor core neutron flux (power level) and provide indication during all modes of reactor operation, and to provide trip signals to the Reactor Protection System (RPS) and the Rod Control System.

In a PWR, the steam generators serve as the preferred method of removing core heat. The SG water level control system automatically adjusts feedwater flow to balance it with steam flow so the water level is maintained at an optimal level.

The pressurizer pressure and level control systems provide automatic controls to keep pressure and level at optimal values. The pressure control system either energizes heaters in the pressurizer or sprays its steam space

with cool water to maintain pressure. The water level control system adjusts the charging and letdown flow in the CVCS system to optimize pressurizer level.

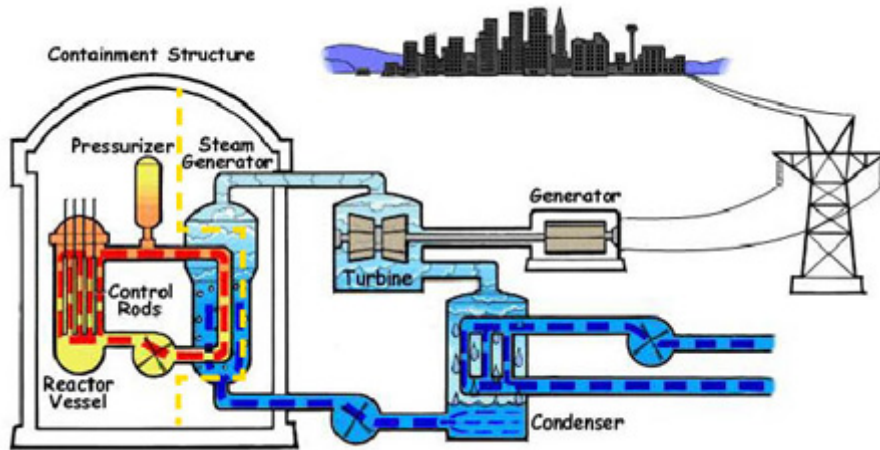

## Secondary Systems (SEC)

Recall that with a PWR, the SG is the dividing line between the primary and secondary systems. Specifically, the tubes inside the SG constitute the dividing line between primary and secondary.

The subsystems in the secondary plant are:

- Steam Generator
- Main Steam
- Turbine
- Condenser

Another important point to remember when discussing the SEC of a PWR is that the steam that turns the turbine does **not** come in direct contact with the reactor core. Therefore, because the steam used throughout the entire SEC does not come into contact with the core it has a lower chance of contaminating the plant.

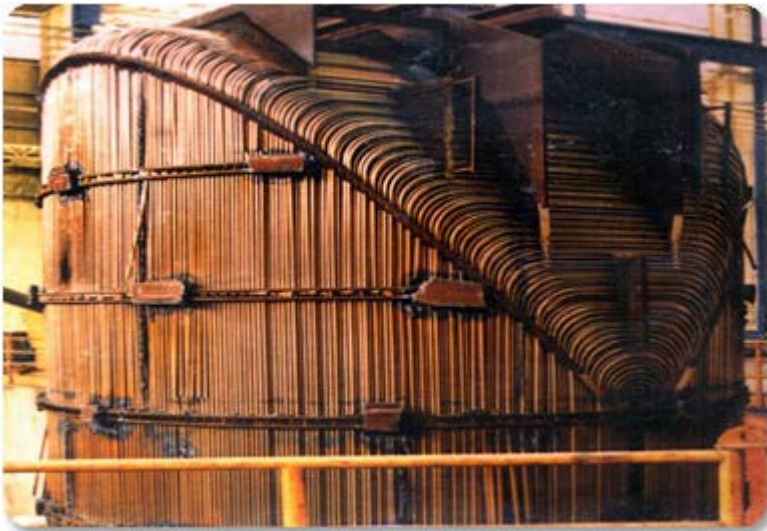

## SEC: Steam Generator (SG)

In a PWR, the [steam generator](#) (SG) is the focal point for separating the primary system from the secondary system.

The SG transfers the heat of the reactor core to relatively cool feedwater, allowing it to boil and produce steam for turning the main turbine. As such, the SG is the primary method that operators rely on to remove reactor heat—including decay heat.

Hot coolant exiting the core is directed into thousands of tubes in the SG. This hot coolant gives up its heat across the tube walls to the feedwater on the secondary shell (outside) side of the tubes. The pressure in the shell side is equivalent to that in a BWR, so the feedwater is allowed to boil and become steam.

After giving up its heat, the now-cooler reactor coolant is pumped back into the reactor vessel by RCPs, where it is reheated and the cycle begins again.

There is a moisture separation system in the top area of the SG much like that in the top of a BWR vessel. Steam is able to make the twisting path through the various dryers, but the water cannot and it drains back down to mix with the incoming feedwater.

Most PWR SGs are U-tube types; a limited number are straight-tube, or once-through, types.



## SEC: Main Steam System

The main steam system of a PWR is almost exactly like that of a BWR. Steam from the SG is directed to the main turbine and to certain other loads (i.e., the feedwater pump turbines, steam dumps, etc.). The steam pipes are generally pretty large and are insulated.

In an emergency, since PWR steam does not come into direct contact with the core, the operator can release or dump steam directly into the environment through valves known as atmospheric dump valves. Normally, the operator prefers to dump steam to the condensers to recover the water and contain any potential radioactivity that might be in the PWR steam.

Main steam can also be used to drive safety-related auxiliary feedwater turbines, providing the operator with an emergency method of pumping feedwater back into the SG. As long as the plant has a way of filling the SG with feed and sending its steam somewhere, the core can be kept cool.

## SEC: Turbine

The turbine is a big, fan-like component that is turned by steam produced by the SG. It takes the thermal energy of the steam and converts it to motion in order to drive the electrical generator. Most power plants use a high pressure turbine, driven by main steam, and coupled to two or three low pressure turbines that are driven by dried and re-heated exhaust steam from the high pressure turbine. There is virtually no difference between PWR and BWR turbines, other than shielding concerns with the BWR.

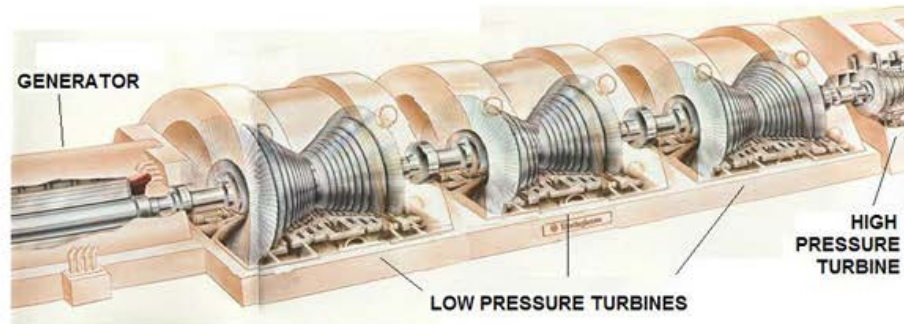

## SEC: Condensate System

Except for the obvious difference that BWR feedwater is sent directly to the core while PWR feedwater is not, the other aspects of the feedwater and condensate systems are virtually identical.

Turbine exhaust steam is collected in large shells known as [condensers](#). The steam is on the outside of thousands of tubes that carry cool circulating water. The hot exhaust steam is cooled and converts back into liquid water that collects at the bottom of the condenser. The liquid is referred to as [condensate](#).

The condensate is then pressurized and heated before it is returned to the secondary side of the SG where it is reheated and boiled. Condensate and feedwater pumps are used to increase the pressure so that the condensate can re-enter the SG. Feedwater heaters, using steam collected from various parts of the secondary plant, warm the condensate and feedwater in stages. By the time the feedwater re-enters the SG, it is ready to boil with little additional heat required.



## Check Your Knowledge

**Which subsystems belong to which main systems?**

Enter the number from the Answer Options in the corresponding field, then select Done.

## Answer Options:

- 1 - Containment system (CONT)                      3 - Secondary System (SEC)  
 2 - Process instrumentation & control (I&C) system

- SG water level control
- Pressurizer pressure and level control
- Steel liner
- SG
- Tendons

## Chapter Summary



### Key Points about System Basics

- With a PWR
  - The steam that turns the turbine does **not** come in direct contact with the reactor core.
  - The water in the reactor core is kept at a very high pressure so that it does **not** boil in the core.
- The division between the primary systems and the secondary systems in a PWR is more concrete than in a BWR. In a PWR, the steam tubes and cooling tubes inside the SG constitute the dividing line between primary and secondary systems. The primary systems have direct contact with, or offer direct support to, the core. The secondary systems provides support to the turbine, condenser, and feedwater for the steam generator.
- The three primary functions of the systems in a PWR are:
  - Steam production
  - Electrical generation
  - Steam exhaust



### Key Points about Subsystems



- PWR plants have the same basic functional systems as BWR plants. The subsystems of those systems vary based on the design and/or manufacturer. A functional system may include subsystems that are in the primary system, the secondary system, or both. The basic functional systems of a PWR include:
  - Reactor Coolant System (RCS)
  - Emergency Core Cooling System (ECCS)
  - Containment System (CONT)
  - Process Instrumentation & Control (I&C) Systems
  - Secondary Systems (SEC)



### Key Points about the RCS

- The reactor coolant system (RSC) allows the operators to maintain and control optimal temperature in the reactor core. Subsystems of the RCS include:
  - Reactor Vessel & Core
  - Reactor Coolant Pumps (RCPs)
  - Chemical & Volume Control System (CVCS)
  - Control Rods and Control Rod Drive System



### Key Points about the ECCS

- The main function of the ECCS is to provide cooling to the core in an emergency. Unlike a BWR, a PWR must also ensure that the core remains sufficiently subcritical (fission reaction shutdown) in case of a steam leak. The ECCS subsystems accomplish this by injecting highly borated water into the core.
- PWR ECCS subsystems are generally comprised of:
  - High Pressure Coolant Injection (HPCI) Pumps
  - Intermediate or Medium Pressure Coolant Injection (MPCI) Pumps
  - Low Pressure Coolant Injection (LPCI) Pumps, also known as RHR pumps (dual duty)
  - Passive Accumulators (ACC)
  - Containment Spray (CS) Pumps
- These systems automatically start in emergencies, but will not inject into the RCS unless pressure drops to specific, low enough levels.



### **Key Points about Containment**

- The high pressure of the PWR primary system and the relatively large quantity of water in systems inside the containment require the containment building to be stronger than the containment of a BWR.
- PWR containment structures include:
  - Concrete over a lattice of rebar
  - Large, tensioned tendons comprised of bundles of metal cables
  - Steel inner liner



### **Key Points about I&C**

- PWRs, like BWRs, include extensive process I&C systems that facilitate monitoring and corrections to the system.
- I&C subsystems include:
  - Reactor protection system (RPS)
  - Neutron monitoring
  - SG water level control
  - PZR pressure and level control



### **Key Points about Secondary Systems (SEC)**

- With a PWR, the SG is the dividing line between the primary and secondary systems. Specifically, the tubes inside the SG constitute the dividing line between primary and secondary systems.
- The key subsystems of the secondary system in a PWR are:
  - SG
  - Main Steam
  - Turbine
  - Condenser

# Health Physics & Radiation Protection

## Chapter Introduction



## Chapter Overview

The effects of radiation on the human body can be both frightening and mysterious to the general public. As an employee of the NRC—no matter your role—family, friends, and members of the public are likely to ask questions related to health impacts of nuclear power plants. This chapter provides an overview of health physics as it relates to the operation of commercial nuclear power plants in the United States (U.S.), and how these power plants relate to other sources of radiation that the general population is likely to encounter.

In this chapter, we will consider terms and concepts related to radiation and health; radiation doses and the resulting effects of those doses on human health; precautions that lead to doses that are as low as reasonably achievable (ALARA); and sources of radiation that the average American is likely to encounter.



## Objectives

After completing this chapter, you will be able to:

- Define key terms related to health physics and radiation protection.
- Differentiate between absorbed dose (RAD/Gray) and equivalent dose (REM/Sievert).
- Differentiate between the effects of Acute and Chronic radiation doses.
- Discuss the ionizing radiation exposure limits by group.
- Identify the three methods of reducing radiation exposure.
- Identify the sources of ionizing radiation in people.

**Estimated time to complete this chapter:**

60 minutes (1 hour)

## Terms for Health Physics

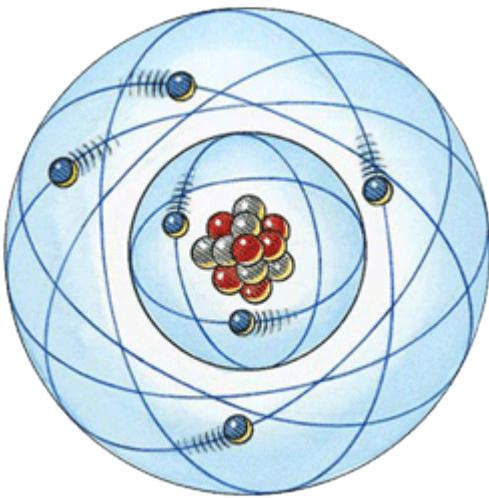

### Radioactive Material

Recall our review of atomic theory from Chapter 2: Fission Process & Heat Production. During that discussion, we explored how an [atom](#) is either stable or unstable. Unstable atoms are called radioactive. Radioactive atoms have excess energy in their [nuclei](#) and will emit that energy in the form of particulate (has mass) or non-particulate (photons) ionizing radiation..

A radioactive atom ejects particles and/or electromagnetic energy called [photons](#). A radioactive material contains atoms that are unstable and attempt to become more stable by ejecting particles, photons, or both. When the particles or photons are ejected, the atom undergoes a process called [decay](#). Each decay event is called a disintegration or transformation.

The particles and/or electromagnetic energy emitted by radioactive material as it decays or disintegrates are called ionizing radiation.

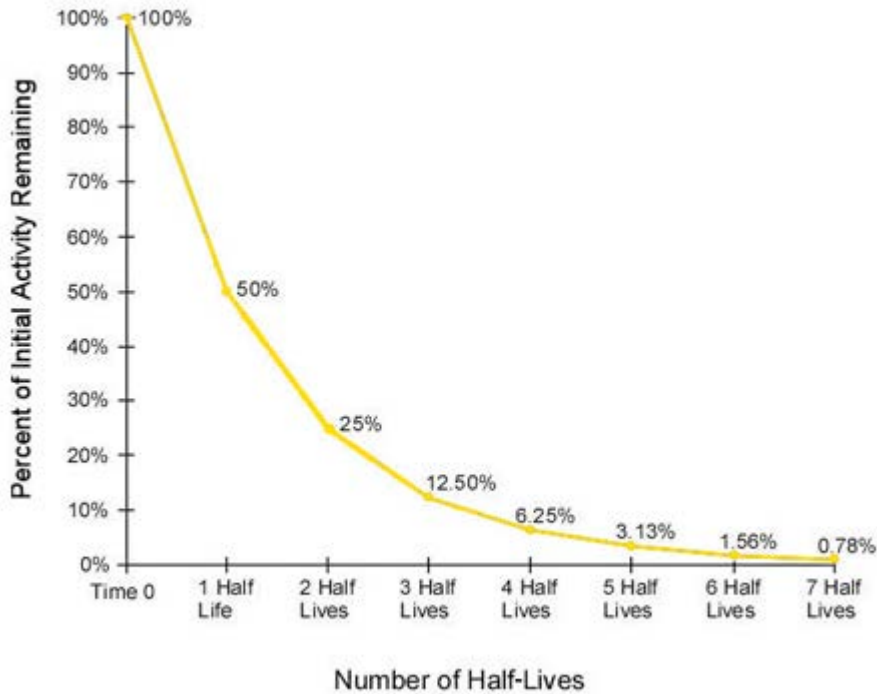

## Half-Life

[Half-life](#) measures a material's rate of nuclear decay. The half-life of any radioactive material is the amount of time it takes for one half of the atoms of a radioactive material to decay. During each half-life, one half of the unstable atoms that started during that half-life period will decay.

Half-lives range from millionths of a second for highly radioactive [fission products](#) to billions of years for long-lived materials, such as naturally occurring uranium. No matter how long or short the half-life is, after seven half-lives have passed less than 1 percent of the initial activity remains.

Radioactive [isotopes](#) have a distinct half-life that does not vary for the particular isotope.

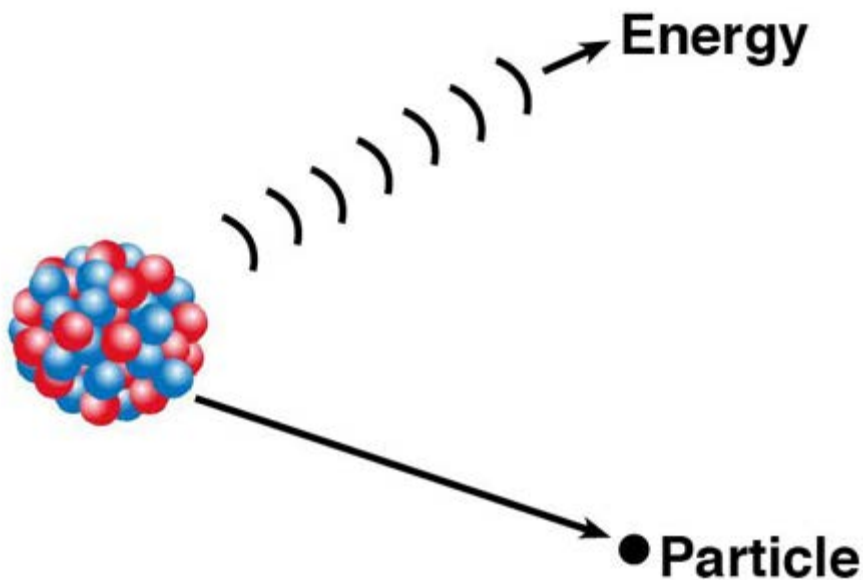

## Ionizing Radiation

[Ionization](#) is the process of stripping, knocking off, or otherwise removing electrons from their orbital paths, thus creating free electrons and leaving behind charged nuclei. The radiation emitted by radioactive material can produce ionizations; this is called [ionizing radiation](#).

The negatively charged electrons and positively charged nuclei may interact with other materials to produce chemical or electrostatic changes in the material where the interactions occur. If these chemical changes occur in the cells of our bodies, cellular damage may result. The biological effects of radiation exposure vary widely and will be discussed in a later topic.

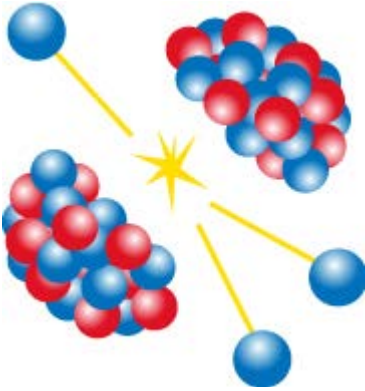

## Particulate Radiation

As mentioned earlier, radioactive material may emit particles, electromagnetic energy in the form of photons, or both. Particulate radiation is ionizing radiation that has mass.

Particulate radiation can present both an internal and external hazard. Internal and external hazards refer to whether the radioactive material is inside or outside of the body.

The types of particulate radiation are:

- [Alpha](#)
- [Beta](#)
- [Neutron](#)

An alpha particle is an ionizing radiation that consists of two protons and two neutrons. The neutrons and protons give the alpha particle a relatively large mass compared to other ionizing radiation particles (8000 times larger than betas). Alphas also have no electrons, giving them a +2 charge.

This relatively large charge and size means the alpha particle has a relatively low penetrating distance (1 or 2 inches in air). The particle tends to travel in a straight line and causes a large number of ionizations in a short distance.

Alpha particles are easily shielded by a thin sheet of paper or the body's outer layer of skin (recall that the outer layer of skin is composed of dead skin cells). Since they do not penetrate the outer layer of skin, alpha particles present little or no hazard when they are external to the body.

However, alpha particles are considered an internal hazard. If ingested, they come in contact with live tissue and have the ability to cause a large number of ionizations within a small distance into the tissue.

A beta particle is a type of ionizing radiation particle that is much like an electron. The charge of a beta particle is equal to that of an electron, but can be positive as well as negative. Its mass is equal to about 1/2000th that of a proton or neutron.

Due to this relatively low mass and charge, beta particles can travel through about 10 feet of air and can penetrate very thin layers of materials, depending on their energy (high energy will mean higher penetrating power or longer travel distances). The energy of beta particles varies depending on the radioactive isotope. However, due to its relatively low mass and charge, most beta particles can penetrate the outer layer of skin.

Energetic betas can travel several feet in air and may also be a hazard to the eyes and other organs of the body. Beta particles are best shielded by thin layers of light metals (such as aluminum or copper) and plastics.

The neutron particle is an ionizing radiation emitted by nuclear fission and by the decay of some radioactive atoms. Neutrons can range from high speed, high energy particles to low speed, low energy particles (called thermal neutrons). Neutrons can travel hundreds of feet in the air and can easily penetrate the human body.

Neutrons are considered both an internal and external hazard; although the likelihood of an internal, neutron-emitting, radioactive material is extremely unlikely. The best shielding materials for neutrons would be those that contain hydrogen atoms (e.g., water, polyethylene, and concrete).

The nucleus of a hydrogen atom contains a proton. Since a proton and a neutron have almost identical masses, a neutron hitting a hydrogen atom gives up a great amount of energy. The lower energy limits the distance that can be traveled by the neutron. It is similar to a cue ball hitting another billiard ball. Since they are the same size, the cue ball may stop and the other ball will start moving. But, if a cue ball is thrown against a bowling ball, the cue ball will bounce off with very little change in velocity and only a change in direction. Therefore, heavy atoms, like lead, are not good at stopping neutrons.

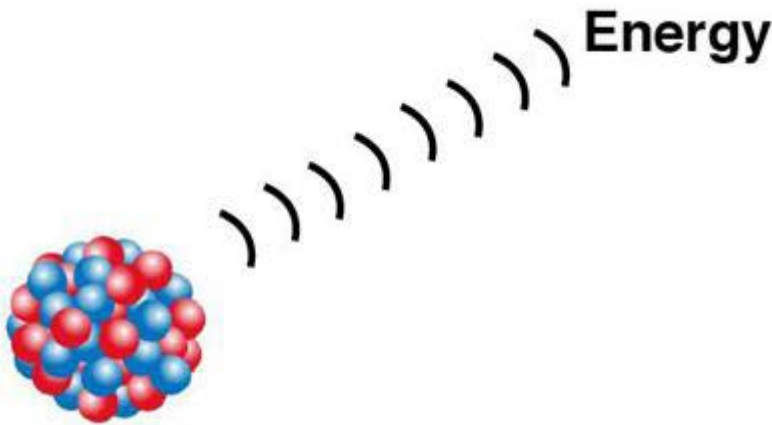

## Non-Particulate Radiation

Non-particulate radiation is radiation emitted as electromagnetic energy in the form of photons. It does not contain any mass.

Non-particulate radiation presents both an internal and external hazard.

The types of non-particulate radiation are:

- [Gamma](#)
- [X-ray](#)



A gamma ray is an ionizing radiation in the form of electromagnetic energy similar in many respects to visible light. As a ray, it has no rest mass and no charge, but is far more energetic than light rays. Due to the high energy, no charge, and no rest mass, gamma rays can travel thousands of feet in air and easily pass through the human body.

Gamma rays are emitted from the nucleus of unstable atoms.

Because of their penetrating capability, gamma rays are considered both an internal and external hazard. The best shielding materials for gamma rays are very dense materials such as lead, concrete, and uranium.

X-rays are similar to gamma rays in penetration and damage potential.

X-rays, however, are emitted from an atom's electron orbital when an electron falls to lower energy levels. They are not emitted from the atom's nucleus.

Since X-rays are a form of ionizing radiation, their use is generally carefully monitored and controlled.

### **Traditional/Special Units and the Système Internationale d'Unites (SI)**

In the US, we use the **traditional** or **special** system when expressing radiation terms. The international community uses the **SI** system. Current NRC documents include both traditional and SI unit figures.

#### **Traditional/Special units:**

- Curie
- [RAD](#)
- [REM](#)

#### **SI units:**

- Becquerel
- [Gray](#)
- [Sievert](#)

An easy way to remember which system's unit correlates with the other system's is:

- Absorbed dose: RAD and Gray both have an "A"
- Dose Equivalent: REM and Sievert both have an "E"

Occasionally, you may also encounter references to Roentgens. The Roentgen is a special unit that is no longer recognized as part of the 10 CFR Part 20. It is being phased out of use by the NRC, but may still be found in older and non-NRC documentation. A Roentgen is approximately equal to a Rad. You may still encounter radiation survey instruments in the industry that read out in Roentgens.

### **Measuring Radioactivity**

Radioactivity is a term that indicates how many radioactive atoms are disintegrating, or decaying, in a time period. It is measured in units of [Curies](#) (Ci) or [Becquerels](#) (Bq). USNRC regulations (10 CFR Part 20) now include both units of measure; older records may only include Ci.

## Curies

Curies is the unit of measure traditionally used in the US. One curie is the amount of any radioactive material that will decay at a rate of 37 billion disintegrations per second. It is based on the disintegration rate of 1 gram of Radium-226.

The amount of material necessary for 1 Ci of radioactivity can vary dramatically. For example, 1 Ci of Cobalt-60 is an amount smaller than a grain of salt, while 1 Ci of Uranium-238 is more than half a ton of material.

## Becquerels

Becquerels is the international unit of measure (SI). The unit of measure is equal to one disintegration per second. Therefore, 1 Ci = 37 billion Bq.

## Measuring Exposure

The special units used for radiation exposure and dose measurements are the RAD and the REM; the SI units are the Gray and Sievert.

### Radiation Absorbed Dose (RAD)

The RAD is a measure of the absorbed dose in any material. An absorbed dose is the energy deposited in material. The radiation dose of record must be recorded in RAD or REM.

One RAD is the deposition of one hundred [ergs](#) of energy in one gram of any material due to the ionization of any type of radiation. NRC Regulations define one gram of body tissue as the material against which doses are measured.

### REM

The REM measures the biological damage caused by ionization in human body tissue. It is a term that measures equivalent dose and equals the biological damage that would be caused by one RAD of dose. The REM accounts for the fact that some types of radiation are more biologically damaging than others. That is, the damage from one RAD deposited by beta radiation is less than that caused by one RAD of alpha radiation.

The REM is numerically equal to the dose in RAD multiplied by a [quality factor](#) (Q), which accounts for the difference in the [amount of biological damage](#) caused by the different types of radiation.

Betas, gammas, and X-rays have a Q of 1. Neutrons have an average Q of 10, while alphas have an average Q of 20. Alpha particles, remember, are an internal hazard only.

One erg of energy is equal to about one ten billionth of a British Thermal Unit (BTU), or about one ten millionth of a watt.

Amount of damage done by one RAD of the types of non-particulate and particulate radiation.

- Non-particulate Radiation
  - Gamma rays: 1 RAD = 1 REM
  - X-Rays: 1 RAD = 1 REM
- Particulate Radiation
  - Beta particles: 1 RAD = 1 REM
  - Alpha particles: 1 RAD = 20 REM

- o Neutron particles: 1 RAD = 20 REM



## Check Your Knowledge

### Match the key terms to their definitions.

Enter the number from the Answer Options in the corresponding field, then select Done.

Answer Options:

- 1 - Ionizing radiation      2 - RAD      3- REM  
 4 - Particulate radiation      5 - Non-Particulate radiation

- Emission of electromagnetic energy in the form of photons only
- Emission of neutrons only, an electron only, or two neutrons and two electrons
- The special unit of absorbed dose of radiation. A dose of one means the absorption of 100 ergs (a small but measurable amount of energy) per gram of absorbing tissue.
- The special unit of dose equivalent. The dose equivalent equals the absorbed dose multiplied by the quality factor, and is a measure of the biological damage.
- Any radiation capable of displacing electrons from atoms or molecules. Some examples are alpha, beta, gamma, x-rays, neutrons, and ultraviolet light. High doses may produce severe skin or tissue damage.

## Radiation Doses

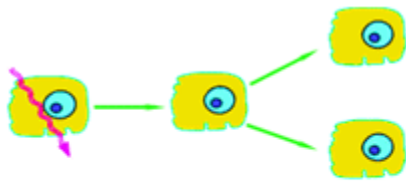
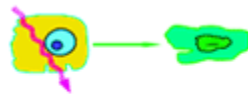
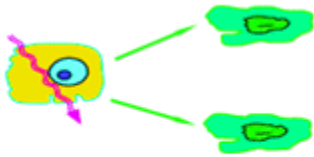
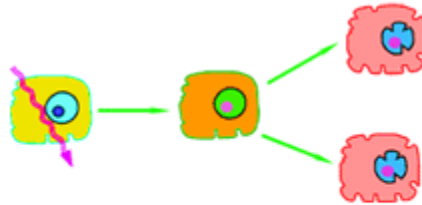
**Normal Repair of Damage****Cell Dies from Damage****Daughter Cells Die****No Repair or Non-Identical Repair Before Reproduction**

## Effects of Radiation on Cells

Damage is progressive, from the atomic level up. People tend to think of biological effects in terms of the effect of radiation on living cells. In actuality, ionizing radiation interacts only with atoms.

Thus, all biological damage effects begin with the consequence of radiation interactions with the atoms forming the cells. As a result, radiation effects on humans proceed from the lowest to the highest levels. Atoms change molecules, which may affect cells, which in turn may affect tissue, then organs, and finally, the whole body.

Luckily, cells have a tremendous ability to repair damage. As a result, not all radiation effects are irreversible. In many instances, the cells are able to completely repair any damage and function normally.

If the damage is severe enough, the affected cell dies. In other instances, the cell is damaged but is still able to reproduce. However, the daughter cells may be lacking in some critical life-sustaining component and may die.

The last possible result of radiation exposure is that the cell is affected and mutates, but does not die. The mutated cell reproduces and perpetuates the mutation. This could be the beginning of a malignant tumor.

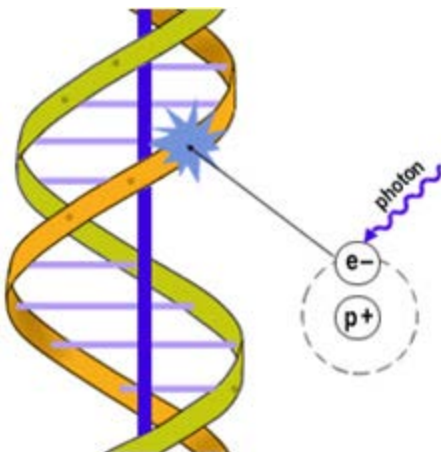

## Mutations

A direct effect occurs when radiation initially interacts with the atoms of the DNA or other cell component's molecules. A direct effect inhibits or changes the ability of the cell to reproduce and/or survive.

If enough atoms are affected such that the chromosomes do not replicate properly, or if there is significant alteration in the information carried by the DNA molecule, then the cell may be destroyed by direct interference with its life-sustaining system.

An indirect radiation effect can occur if the ionization creates a later chemical action due to the formation of free radicals or other radiation products. This ionization can disrupt the normal chemistry of the cell and cause it to die. These chemical changes can also induce a mutation in the cell much like a direct change to its DNA might.

There have not been any observation in humans of mutations caused by ionizing radiation that are not also caused by other mutant effects (like smoking, chemical exposure, spontaneous mutations, etc.).

## Calculating Dose

Recall that the RAD is the amount of radiation necessary to affect 1 gram of any material, while 1 REM is the measure of the biological damage done by 1 RAD of ionizing radiation. The quality factor (Q) converts the absorbed dose (RAD) to the dose equivalent (REM). The table shows the relative damage based on the Q value for the given radiation types. These are average values; neutrons, for example, have a range based on factors like their energy.

The equation for calculating dose is:

$$\text{REM} = \text{RAD} \times \text{Q}$$

The units used in a discussion of radiation and radioactivity may have prefixes to indicate fractions or multiples of the standard unit. The only common prefix used in this training is milli- (one thousandth).

$$1 \text{ REM} = 1000 \text{ mREM}$$

Table 1 Energy deposited by radiation type and the resulting damage.

Energy Deposition	Damage
1 RAD Gamma	1 REM
1 RAD Beta	1 REM
1 RAD Neutron	10 REM
1 RAD Alpha (internal)	20 REM

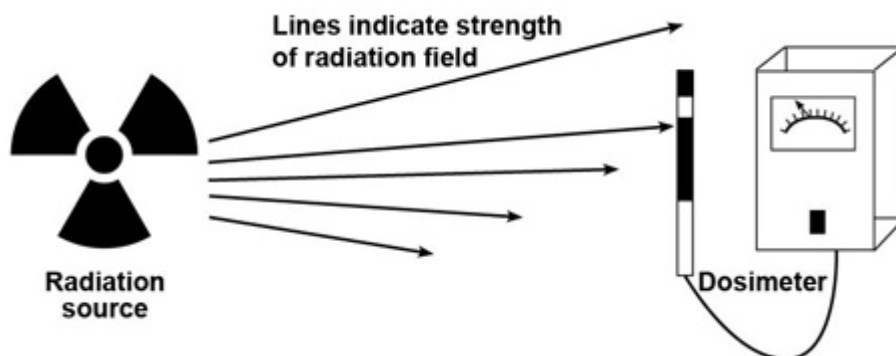

## Calculating Dose: Dose Rate

The dose rate is the rate at which a person would or did receive a radiation dose or [dose equivalent](#). It is a measure of radiation dose intensity, or strength, in some unit time period. The amount of dose received depends on the:

1. Strength of the radiation field
2. Amount of time exposed to the radiation

Commonly used dose equivalent rates are:

- mrem/hr
- rem/hr
- mrem/wk
- rem/wk
- rem/quarter
- rem/year



## Calculating Dose

The dose received is equal to the dose rate multiplied by the length of time spent in that field.

### Dose = Dose Rate X Time

For example, if John spent 1/2 hour in a location with a dose rate of 50 mrem/hr, his dose would be 25 mrem. Let's look at the calculation.

Dose = Dose Rate x Time

$$= 50 \text{ mrem/hr} \times 1/2 \text{ hour}$$

$$= 25 \text{ mrem}$$



### Calculating Dose: Stay Time

Stay time is an important calculation for those working within radiation areas. It is the length of time an individual may remain in a radiation field of some strength before exceeding a pre-defined dose limit (administrative limit).

#### Stay Time = Dose Limit ÷ Dose Rate

Let's consider John again. He has a predetermined dose limit of 100 mrem. The dose rate where he is working is 50 mrem/hr. How long can John work in that location?

Stay Time = Dose Limit ÷ Dose Rate

$$= 100 \text{ mrem} \div (50 \text{ mrem/hr})$$

$$= 2 \text{ hours}$$

John's stay time at his current work location is 2 hours, as long as the dose rate doesn't change.



## **Types of Doses**

Biological effects of radiation are typically divided into two categories: Acute and Chronic. Time and intensity of exposure define the two categories.

### **Acute**

Acute represents exposure to high doses of radiation over short periods of time producing acute effects. High doses tend to kill cells, while low doses tend to damage or change them. High doses can kill so many cells that tissues and organs are damaged. This in turn may cause a rapid whole body response called Acute Radiation Syndrome (ARS). An example of an acute dose would be that received by survivors of the Hiroshima or Nagasaki bomb blasts.

### **Chronic**

Chronic represents exposure to low doses of radiation over an extended period of time producing chronic effects. Low doses spread out over long periods of time don't cause an immediate problem to any body organ. The effects of low doses of radiation occur at the level of the cell, and the results may not be observed for many years. Occupational workers at nuclear facilities generally receive what is called chronic dose.





## Acute Radiation Syndrome

Acute Radiation Syndrome (ARS) occurs when a large, short-term, whole-body dose of radiation simultaneously damages a number of vital tissues and organs. ARS effects will vary from person to person depending on factors like age, health, and magnitude of dose. There are three types of ARS, which will be discussed on the next page.

The initial signs and symptoms of any ARS are:

- Nausea
- Vomiting
- Fatigue
- High Temperature
- Blood changes

Below about 100 RAD, these symptoms, which are no different from those produced by a common viral infection, may be the only outward indication of radiation exposure.



## ARS: Manifestation

As the dose increases above 100 RAD, one of the three radiation syndromes begins to manifest itself, depending on the level of the dose.

Recall that the three types of ARS are:

- [Hematopoietic](#)
- [Gastrointestinal](#)
- [Central Nervous System](#)

Hematopoietic radiation syndrome effects the blood forming organs, such as bones. Of the three syndromes, this is one to which the human body is most sensitive. In other words, hematopoietic ARS is the syndrome most likely to develop in someone who has received a high dose of radiation and show symptoms earlier.

Gastrointestinal ARS affects the stomach, liver, pancreas, and intestine. Of the three types of ARS, this is the one to which the human body is moderately sensitive to compared to the other two. It is important to remember, however, that the human body is sensitive to all radiation.

Central Nervous System ARS affects organs such as the brain, muscles, and nerves. Of the three types of ARS, this is the one to which the human body is the least sensitive; this type of ARS requires the highest dose to cause symptoms.

Table 2 Dose in RADs and corresponding observable effects for exposure of 1 hour or less

Dose (RAD)	Effect Observed
15 – 25	Blood count changes in a group of people
50	Blood count changes in an individual
> 50	Sterility in males
100	Vomiting (threshold)
150	Death (threshold)
320 – 360	LD 50/60 with minimal medical care
480 – 540	LD 50/60 with supportive medical care
1,100	LD 50/60 with intensive medical care and bone marrow transplant

## High Dose Effects

Every acute exposure does **not** result in death. If a group of people is exposed to a whole body penetrating radiation dose, the effects in the table might be observed. The information for this table was extracted from NCRP Report No. 98, Guidance on Radiation Received in Space Activities, 1989.

In the table, the threshold values are the doses at which the effect is **first** observed in the **most sensitive** of the individuals exposed. For example, with a dose of 100 RAD, the most sensitive of people exposed will begin to vomit.

The LD 50/60 is the lethal dose at which 50% of those exposed to that dose will die within 60 days.

It is sometimes difficult to understand why some people die while others survive after being exposed to the same radiation dose. The main reasons are the health of the individuals at the time of the exposure and their ability to combat the incidental effects of radiation exposure, such as the increased susceptibility to infections.

## Low Dose Effects

There are two general categories of effects resulting from exposure to low doses of radiation. They are genetic effects and somatic effects. But, keep in mind: high dose can cause the same effects.

A genetic effect is suffered by the offspring of the individual exposed. Recall our earlier discussion of the direct effect of ionizing radiation on DNA. The genetic information in the DNA can be altered or lost through many different interactions with chemical and physical (like ionizing radiation) agents. At present, there have been no **observed** genetic effects to human beings from ionizing radiation.

A somatic effect is suffered by the individual exposed. Cancer in the exposed individual is an example of a somatic effect; therefore it is also considered a carcinogenic effect.

Some mistakenly consider in-utero (unborn fetus/embryo) effects to be a **genetic** consequence of radiation exposure, because the exposure occurs prior to birth and the effect is seen after birth. However, this is actually a special case of the somatic effect, since the embryo/fetus is the individual exposed to the radiation (in addition to the mother). It is the exposure of the embryo/fetus that results in the manifestation of this somatic effect, not the result of DNA changes inherited from the mother.



### **NRC Dose Limits: Members of the Public**

The NRC limits the dose that members of the public can receive from the handling and use of radioactive or by-product materials. The limits are:

- Less than 2 millirem in any 1 hour from external radiation sources in any unrestricted area
- Less than 100 millirem in a calendar year from both external and internal sources of radiation in unrestricted and controlled areas

Additionally, the NRC has provided design objectives for power reactor licensees to keep offsite doses as far below the 10 CFR Part 20 limits as is reasonably achievable. Reactor Power Plant Operating Criteria can be found in 10 CFR Part 50.

Permissible dose levels in unrestricted areas during the transport of radioactive material can be found in 10 CFR Part 71.

The Environmental Protection Agency (EPA) also has established various limits for power reactors discharging into local streams. Read 40 CFR Part 190 for the specifics.

### **NRC Dose Limits: Occupational Workers**

The NRC exposure limits apply to all NRC licensees' occupational workers and are designed to ensure that:

1. No worker at a nuclear facility receives an acute radiation exposure sufficient to result in deterministic effects (e.g., cataracts).
2. The risk of cancer (although not zero) is not higher than the risk of cancer from other occupations.

No matter the limit number, licensees are also required by 10 CFR Part 20 to keep radiation exposures as low as reasonably achievable (ALARA).

Planned Special Exposure (PSE) is an infrequent exposure for a special, high-dose job. The yearly PSE limit is equal to the annual limit with a lifetime maximum of five times the annual limit. For example, the PSE limit for the whole body is 5 REM in a year, in addition to the above occupation limits, with a lifetime maximum of 25 REM.

Table 3 Degree of exposure and corresponding annual dose limits

Degree of Exposure	Annual Limit
Whole Body (internal & external dose)	5 REM*
Extremities (this is SDE: considered a Skin limit) (elbows and arms below the elbows, and knees and legs below the knees)	50 REM
Skin of the Whole Body	50 REM*
Maximum Exposed Organ (internal & external dose)	50 REM
Lens of the Eye	15 REM
Minors (worker less than 18 y.o.)	500 mREM
Declared Pregnant Worker (DPW) and Embryo/Fetus	500 mREM**

\*The whole body and skin of the whole body includes all of the body except the elbows and arms below the elbows, and knees and legs below the knees.

\*\*The limit applies over the gestation period (pregnancy) rather than a year.



## Check Your Knowledge

**Which items are applicable to RAD and which are applicable to REM?**

Enter the number from the Answer Options in the corresponding field, then select Done.

Answer Options:

1 - RAD      2 - REM

- Refers to absorbed dose
- Sievert in SI units
- Refers to dose equivalence
- Gray in SI units

- Measures the amount of damage to the body
- Measures the amount of radiation effecting the body



## Check Your Knowledge

### Which items apply to acute and which apply to chronic radiation doses?

Enter the number from the Answer Options in the corresponding field, then select Done.

Answer Options:

1 - Acute      2 - Chronic

- Produces long-term effects
- Produces short-term effects
- High dose over short period
- Typically kills cells
- Typically damages cells
- Low to moderate dose over long period



## Check Your Knowledge

### Match the exposure limits to the group.

Enter the number from the Answer Options in the corresponding field, then select Done.

Answer Options:

1 - Nuclear Workers      2 - Public      3 - Declared Pregnant Worker

- Less than 2 millirem per hour

- Less than 100 millirem in a calendar year
- 500 mREM annual limit total
- Whole body annual limit of 5 REM
- Applicable annual limit is for approximately 9 months

## ALARA



### Dosing and ALARA

Recall that no matter the dose limit established by the NRC, licensees are required to keep radiation exposures as low as reasonably achievable. The regulation outlines the standards for protection against radiation for nuclear workers. The goal of ALARA is that all exposure be **As Low As Reasonably Achievable**.

### ALARA Standards

Guidance for ALARA is documented in 10 CFR 20:

- Radiation Protection Programs
- Limits for Occupational Exposure
- Limits on Exposure of the Public
- Required Surveys and Monitoring
- Radioactive Material Storage and Disposal
- Respiratory Protection Programs

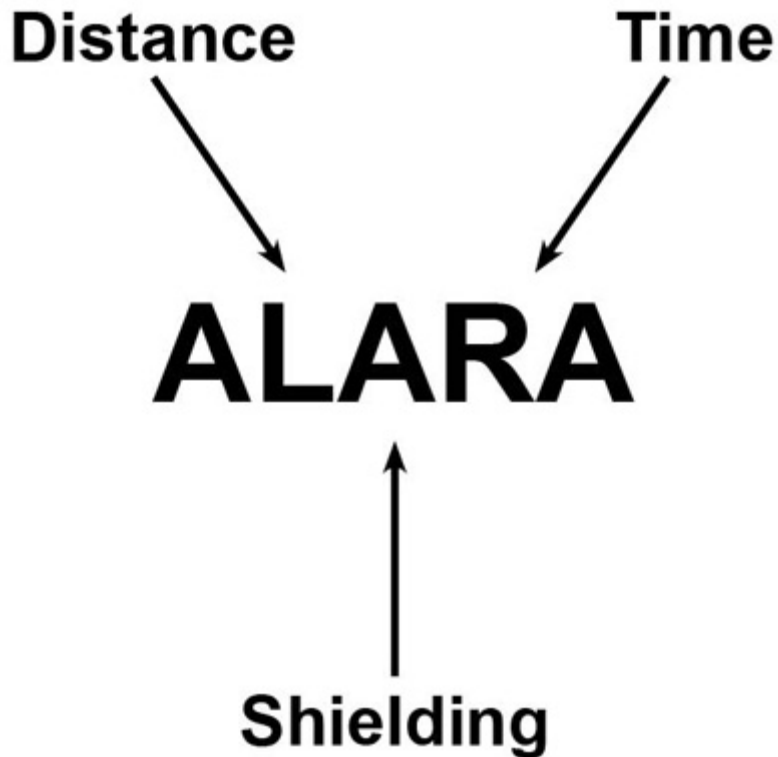

### **ALARA Achievement Methods**

Three protective measures are used to reduce the dose from any external source of radiation. The three methods are:

- Minimize time
- Maximize distance
- Maximize shielding

Time and distance are also applicable for reducing the internal dose of radioactive material. However, once the radioactive material is inside the body, you must employ methods like medical use of chelating agents to remove the material from the body.

The total dose is the sum of internal and external doses. Total dose should be minimized, since overall risk is proportional to the total dose. In some cases, this may mean accepting a small intake of radioactive material to reduce the external dose.

The important thing is to keep the total dose As Low As Reasonably Achievable.





### Achievement Methods: Time

The dose a person receives from external radiation is directly proportional to the length of time spent in a radiation field. Minimizing the amount of time spent in a radiation field minimizes the dose received. Strategies that can minimize time spent in a radiation field are:

- Plan and rehearse the job under realistic conditions
- Know the exact location of work prior to entering the radiation area
- Ensure all necessary tools are available at the job location
- Establish good communications
- Do not loiter in the area (establish Low Dose Waiting Areas)

Similarly, minimizing the time spent in an area with airborne radioactivity will minimize the internal dose, since the intake of radioactive material is directly proportional to the inhalation time volume of air being breathed.

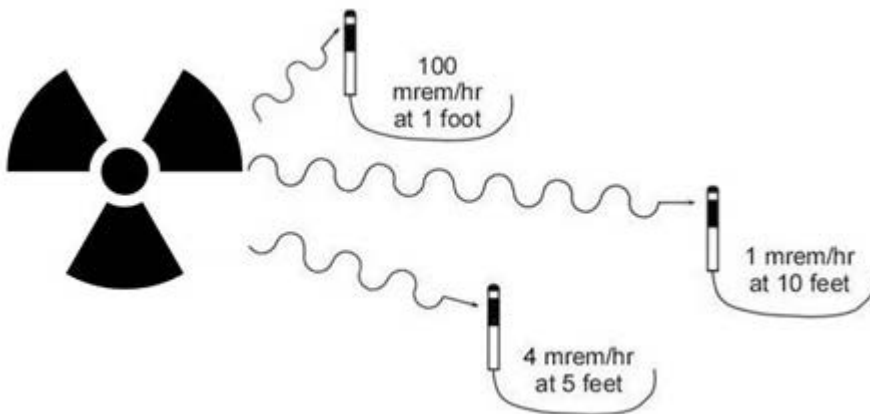

### Achievement Methods: Distance

The radiation dose from sources can be significantly reduced by applying the protective measure of distance.

The dose a person receives from an external radiation source is inversely proportional to the distance from the source. The farther you are away: the lower your dose.

$$\text{Dose} = 1/d^2$$

To calculate a difference in dose between two distances, you multiply the inverse of the ratio of the two

distances by itself. Therefore, if the dose rate at one foot is 100 mrem/hour, the dose rate at 10 feet would be  $1/(10 \text{ ft}/100 \text{ ft})^2$  of that, or 1 mrem/hour. Some ways to increase the distance are:

- Using extension tools
- Utilizing remote operating stations
- Staying away from hot spots

Staying as far away as possible from a source of airborne radioactivity minimizes the intake of radioactivity because the activity disperses and becomes less concentrated as it moves away from the point of release.

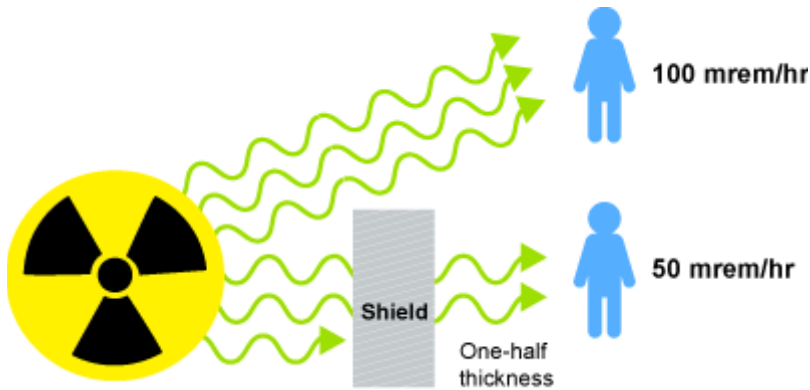

### Achievement Methods: Shielding

Shielding is one of the most effective means of reducing radiation exposure. A shield simply absorbs the radiation before it can affect anything else, and [shielding materials](#) differ in their ability to absorb radiation.

By locating the shielding as close as possible to the source, dose rates can be reduced in a large area, and thus reduce the dose to many workers.

The two major types of shielding at the plant are:

- [Installed shielding](#)
- [Temporary shielding](#)

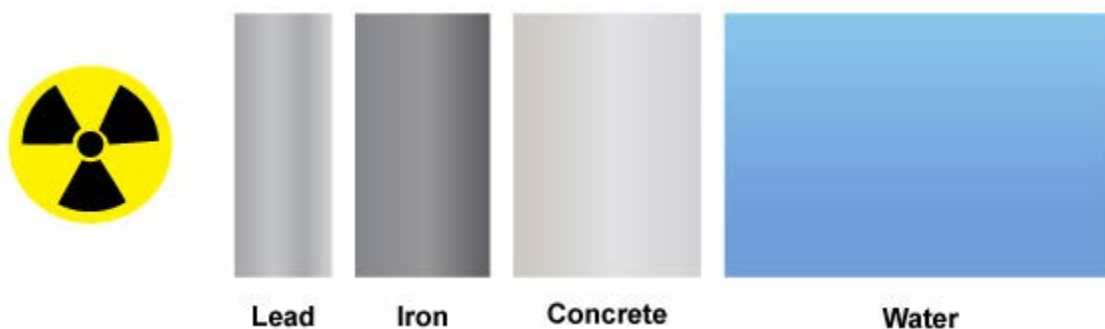

Common shielding materials include lead, iron or steel, concrete, and water. To have the same gamma radiation exposure level at the outside of each material, it takes about twice as much iron as lead, about twice as much concrete as iron, and about three times as much water as concrete.

As a rule of thumb, it takes 2 inches of lead to reduce the dose rate by a factor of 10. If a radiation detector measured the dose rate at a certain distance to be 100 mrem/hour, then 2 inches of lead would reduce the dose rate to 10 mrem/hour. This value is called a tenth-value thickness of lead.

To accomplish the same reduction using the other materials would require 4 inches of iron or steel, 8 inches of concrete, or 24 inches of water. Note that these values are only thumb rules. The exact amount of material required depends upon the energy of the radiation (gamma ray) that is being shielded against.

Installed shielding is permanent shielding installed at the plant for the purpose of reducing the radiation levels in some areas. An example of permanent shielding is the concrete shield walls located in the containment.



Temporary shielding can take the form of lead sheets, lead bricks, or bags filled with lead shot. This type of shielding can be placed near the source to reduce the radiation levels in large areas. It can also be shaped as needed to provide the maximum shielding effectiveness.



## Contamination

Contamination generally refers to a quantity of radioactive material in a location where it is neither intended nor desired. Radioactive contamination can be fission products that have escaped the system or structure that would normally contain them, or activated corrosion products that do the same thing. Radioactive contamination can be wet or dry, fixed or removable, and settled or airborne. Since radioactive contamination is radioactive material, ionizing radiation is emitted by the contamination.

## Contaminated Areas

A contaminated area is an area that contains radioactive contamination. Some examples of contaminated areas that require periodic access would be the primary side of the steam generator for a pressurized water reactor and the main turbine for a boiling water reactor.

## Protective Measures

[Protective measures](#) are used to prevent, detect, and/or contain radioactive contamination. Since radioactive contamination can be inhaled and/or ingested, the protective measures are considered to be methods of protection against both internal and external doses.

Common protective measures include:

- Utilize containments
- Maintain access control
- Conduct frequent surveys
- Utilize protective clothing
- Wear respiratory protection
- Practice good housekeeping
- Conduct follow-up bioassays
- Minimize radioactive leakage

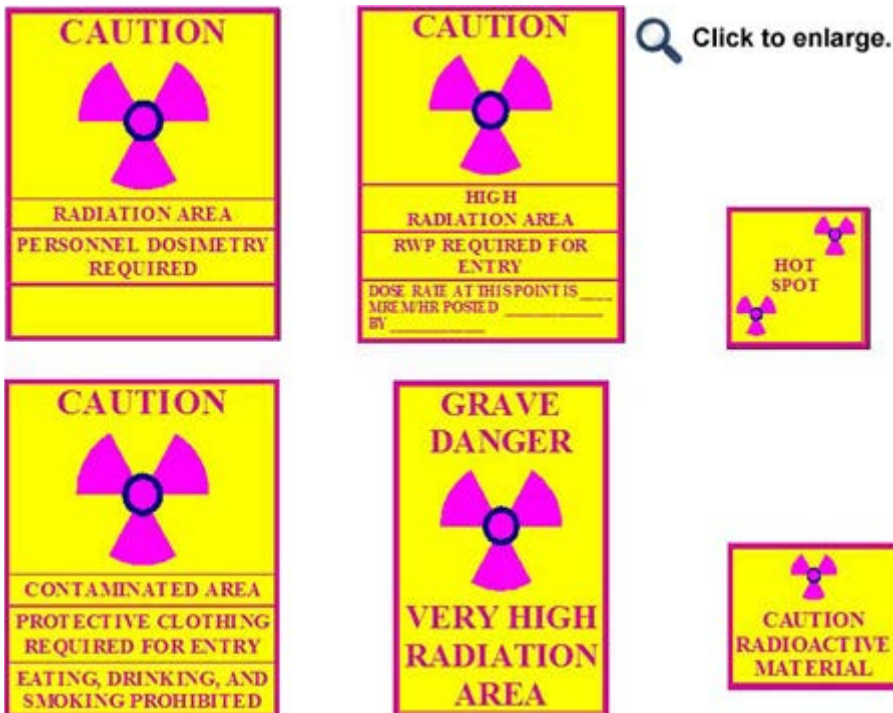

## Signs and Labels

Radiation signs and labels are commonly used to warn people of radiation areas, contaminated areas, and locations where radioactive material is found.

Signs in the US are magenta (purple) on a yellow background; caution signs in the US may have either magenta or black on the yellow background. The international symbol for radioactive material and radiation is a magenta (or black) three-bladed design on a yellow background.

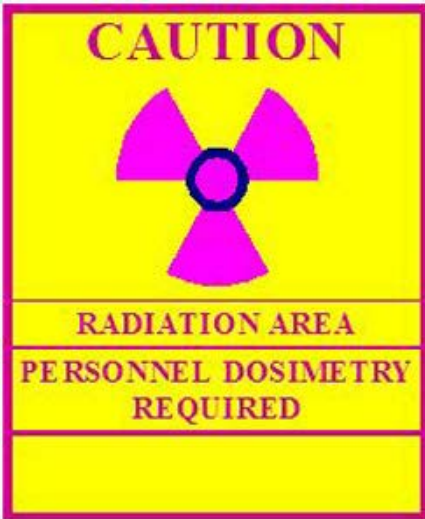

### Check Your Knowledge

1. What are the methods for reducing radiation exposure in order to keep a dose as low as reasonably achievable?

Select your answer, then select Done.

- Minimize shielding, time, and distance
- Maximize shielding, time, and distance

- Maximize distance, but minimize time and shielding
  - Minimize distance and time, but maximize shielding
  - correct: Minimize time, but maximize distance and shielding
2. Correct. The three methods for achieving ALARA are to minimize the time of exposure, maximize the distance from the source, and maximize the amount of shielding.
  3. Incorrect. The three methods for achieving ALARA are to minimize the time of exposure, maximize the distance from the source, and maximize the amount of shielding.

## Sources of Radiation Exposure

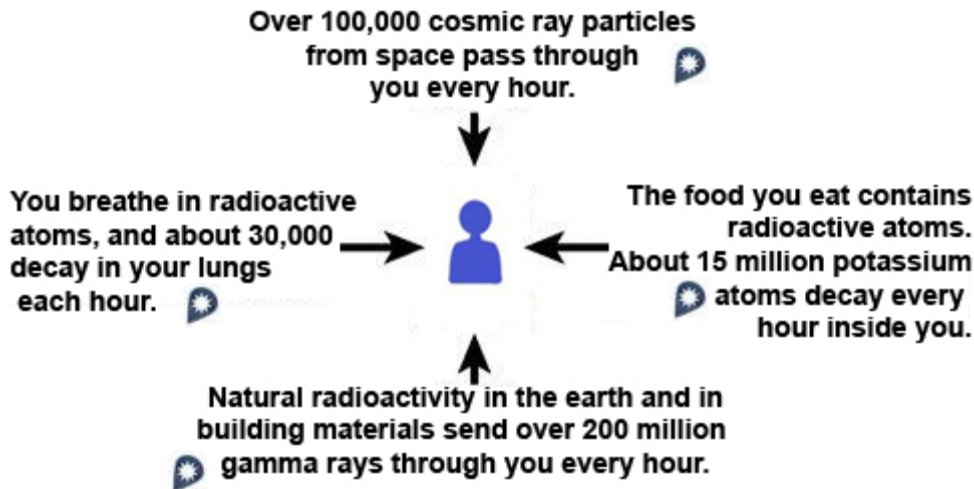

## Background Radiation

Background radiation is radiation that people are exposed to as part of living on the Earth; it does not include occupational radiation from working in the nuclear field. It is important to remember that radioactivity is a naturally-occurring process, as well as a man-made one.

Natural background radiation comes from:

- Cosmic sources
- Naturally-occurring radioactive materials
- Internal radiation

Man-made background radiation comes from:

- Atmospheric fallout from the testing of nuclear weapons
- Building and other consumer materials
- Medical procedures/diagnostics

The two strongest sources of natural background radiation are cosmic radiation and terrestrial sources of naturally occurring radioactive materials.

Over 100,000 cosmic ray particles from space pass through you every hour.

You breathe in radioactive atoms, and about 30,000 decay in your lungs each hour.

The food you eat contains radioactive atoms. About 15 million potassium atoms decay every hour inside you.

Natural radioactivity in the earth and in building materials sends over 200 million gamma rays through you every hour.

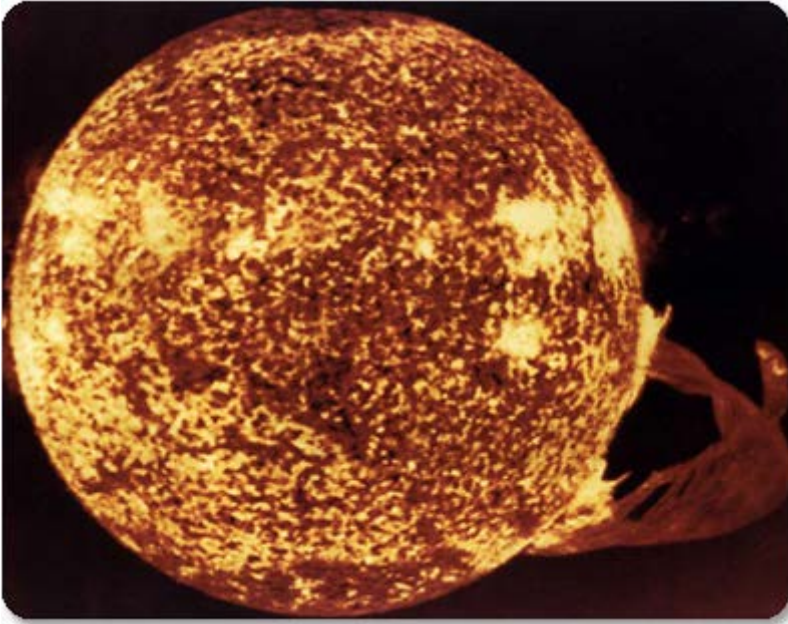

## Cosmic Radiation

The Earth is constantly bombarded by radiation from space, similar to a steady drizzle of rain. Charged particles from the sun and stars interact with the Earth's atmosphere and magnetic field to produce a shower of radiation. The dose from cosmic radiation varies in different parts of the world due to differences in elevation and to the effects of the Earth's magnetic field.

The atmosphere serves as a shield reducing the amount of cosmic radiation reaching the Earth. At higher altitude, there is less shielding so the level of cosmic radiation is higher.



## Terrestrial Radiation

Radioactive material is also found throughout nature. It is found in the soil, water, and vegetation. Low levels of uranium and its decay products are found everywhere. People regularly ingest low levels of radioactive materials with food and water. Other materials, such as radon, can be inhaled. This leads to all living creatures on Earth having some level of natural radioactive material in their bodies, which results in dose to themselves

and others around them.

The dose from terrestrial sources varies in different parts of the world. Locations with higher concentrations of uranium and thorium in the soil have higher dose levels. Living near some granite rock formations can result in exposures of 25 to 100 mrem/year. Working in buildings made of stone can also contribute to higher background doses.

The major isotopes of concern for terrestrial radiation are uranium and the decay products of uranium (i.e., thorium, radium, and radon).

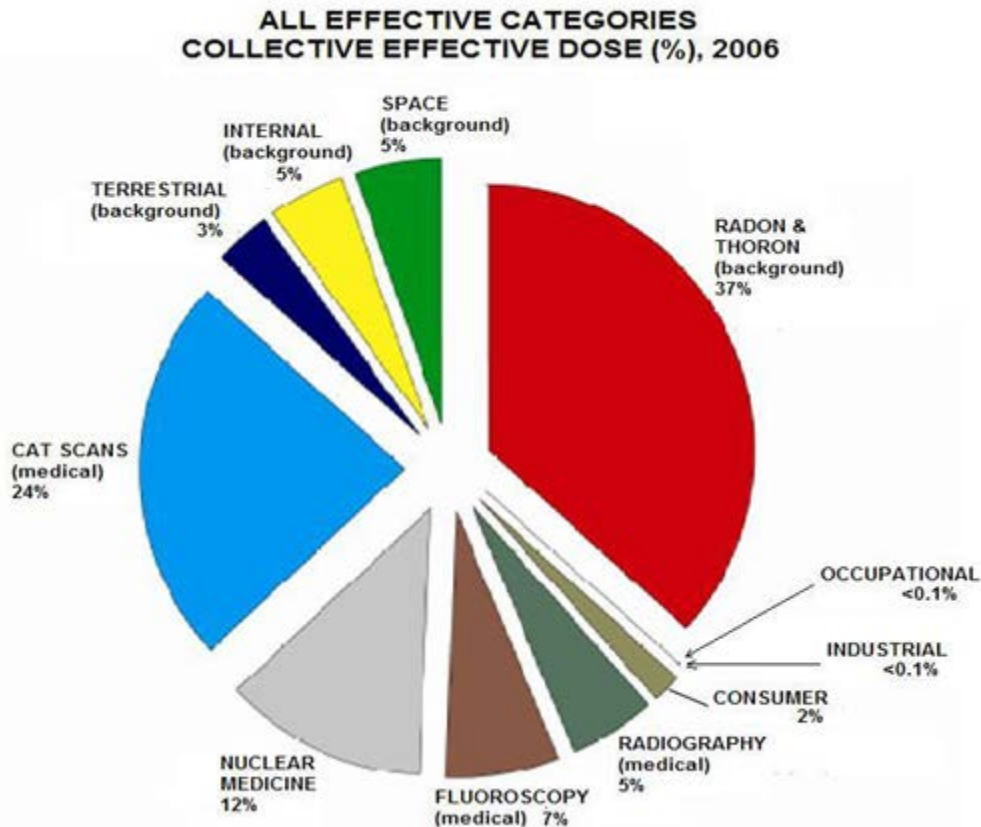

## Medical Doses

In recent years, a significant change to the average U.S. dose is the large increase in ionizing radiation received from medical treatments. Up until the 1990's, the average American received approximately 1 mrem per day from natural sources (about 360 mrem per year).

Recent studies show the average American's dose from natural/background radiation is almost 2 mrem per day (approximately 620 mrem per year). The great majority of this increase is from medical and diagnostic exposure.

The annual dose to the average American as of 2006 is about 50% natural background and 50% man-made (mostly medical). If a person doesn't receive any medical exposure, their background dose levels will resemble the previously established 1 mrem per day range.





## Nuclear Power Plants

Now that we've looked at some natural or man-made sources of ionizing radiation, let's consider sources associated with nuclear power plants.

Nuclear workers are the individuals most likely to receive a dose of radiation from a nuclear power plant. The sources of ionizing radiation at nuclear power plants include:

- Natural fuel decay
- Fission process
- Fission products
- Activation products

In addition, both nuclear workers and members of the public can be exposed to radiation from the nuclear fuel cycle, which includes the entire sequence from mining and milling of uranium to the actual production of power at a nuclear plant. This would be uranium and its daughter products.



## Natural Fuel Decay

Uranium-238 (about 96% of the fuel) and Uranium-235 (the remaining 4%) are naturally radioactive and decay by the emission of alpha particles and gamma rays into daughter products. Beta particles are also released from the fuel as the daughter products continue the natural decay process toward a stable form lead.

Since the fuel is sealed in airtight fuel rods, there should be little or no alpha or beta radiation problem at the nuclear plant due to the natural decay of the fuel unless there is some fuel rod damage.

The natural decay process of the fuel is not a major contributor to a worker's dose at the power plants. This is because of the low radiation levels associated with new fuel that has not operated in the reactor core.

## Fission Process and Fission Products

During the fission process, uranium atoms produce fission products. Powerful gamma rays and high-speed neutrons are released during and immediately following the fission process. Since neutrons and gamma rays can travel long distances in air, very high radiation levels are present in the vicinity of the reactor vessel during power operation.

The fission process is not a major contributor to a worker's dose at the power plants. This is because the fission process is occurring in the reactor core, which is contained in the reactor vessel. The reactor vessel is surrounded by a biological shield wall inside the containment, and workers are not normally allowed around the reactor vessel during operation.

The fission products are intensely radioactive. Most of these fission products decay rapidly. However, several have very long half-lives and decay slowly. By design, the decay of the fission products generally occurs within the reactor vessel, and is not a significant contributor to the radiation dose of workers.

The most likely time that workers could be exposed to the radiation is during refueling. However, refueling is

performed under water to limit the radiation dose the workers receive.

Since a fission product release could seriously jeopardize public health and safety and the environment, fission product barriers are part of every power reactor design. Recall from Chapter 1 that the fission product barriers are the fuel rod cladding, the reactor coolant system (RCS), and the containment building.

## Neutron Activation

Impurities in the RCS and the reactor coolant water absorb some of the neutrons produced during the fission process. They then change from a stable form to an unstable form. Even the water in the coolant can be activated: hydrogen to deuterium and/or tritium, and oxygen to radioactive nitrogen. This is called activation and the radioactive isotopes formed are called activation products.

Activation products are located in the RCS and are easily transported to any support system that connects to the RCS. Activation products are the source of most radioactive contamination at nuclear power plants and are also the source of most occupational radiation exposure at the plants.

Deposits of the activation products or any other impurities on RCS surfaces are called crud. Prior to going into a refueling outage, some plants add a chemical to the RCS to force the crud off the surfaces, and then use the reactor water cleanup system to remove the material from the coolant. This reduces the risk of exposure to workers during the outage.

## Neutron Activation (continued)

The table shows some of the fission products produced by fission or the activation products produced by neutron absorption. The first five isotopes are fission products and the remaining four are activation products. These materials are of interest because of their:

- Relatively long half-life
- Relatively large abundance in the reactor
- Ability to chemically interact in biological systems

Also of interest are water activation products. Water activation products are those activation products that are susceptible to interacting with water molecules. The two most significant are:

- [Tritium](#)
- [Nitrogen-16](#)

*Table 4 Fission products with their radiation type and half-life*

<b>Material</b>	<b>Radiation</b>	<b>Half-life</b>
Krypton-85	Beta/Gamma	10 years
Strontium-90	Beta	28 years
Iodine-131	Beta/Gamma	8 days
Cesium-137	Beta/Gamma	30 years
Carbon-14	Beta	5770 years
Zinc-65	Beta/Gamma	245 days
Cobalt-60	Beta/Gamma	5 years
Iron-59	Beta/Gamma	45 days
Tritium (H-3)	Beta	12 years

Tritium is both an activation product and a fission product. It is a major hazard if ingested into the body because it replaces the hydrogen in the water that makes up cells and result in an internal dose. Specific release limits on tritium can be found in 10 CFR 20.

Because tritium is actually a hydrogen atom that is part of the water molecule it is difficult or impossible for the radioactive waste handling systems to remove it from the water processed for release from the plant.

Of extreme importance is the isotope Nitrogen-16 (N-16). This isotope has a very short half-life (about seven seconds), but emits an extremely powerful gamma ray.

N-16 is formed when an Oxygen-16 atom absorbs a neutron and decays. Since every molecule of water has an oxygen atom, there is a large amount of N-16 produced in the core.

N-16 is a major concern for shielding due to the high energy of the gamma ray emitted. Also, any system (BWR Main Steam system) that contains primary coolant and exits containment must be of concern. One method of minimizing the radiation from N-16 is to allow the flow of coolant to circulate in a loop for a time period that permits the N-16 to decay, or by slowing down the flow to allow the decay. About a 1 minute delay is sufficient.



## Check Your Knowledge

- **What are the sources of ionizing radiation to which members of the public can be exposed?**  
Select all that apply, then select Done.
  1. correct: Cosmic radiation
  2. correct: Terrestrial radiation
  3. Nuclear fission from reactors
  4. Neutron activators such as tritium
  5. correct: Nuclear fuel cycle
- Correct. Everyone on Earth is exposed to background radiation in the form of cosmic radiation and terrestrial radiation. Everyone is also exposed to trace amounts as a result of the nuclear fuel cycle. However, only nuclear workers are likely to ever be exposed to radiation from nuclear fission in a reactor or neutron activators. Due to safety procedures, their exposure would be minimal - as low as reasonably achievable.
- Incorrect. Everyone on Earth is exposed to background radiation in the form of cosmic radiation and terrestrial radiation. Everyone is also exposed to trace amounts as a result of the nuclear fuel cycle. However, only nuclear workers are likely to ever be exposed to radiation from nuclear fission in a reactor or neutron activators. Due to safety procedures, their exposure would be minimal - as low as reasonably achievable.

## Chapter Summary



## Key Points

- Half-life measures the rate of a material's nuclear decay. It is the amount of time it takes for half of a radioactive material to decay into some other material.
- Ionizing radiation is radiation that produces ionizations. Ionization is the process of removing electrons from their orbital paths. This creates free electrons and charged nuclei. Ionizing radiation may lead to chemical reactions within living cells.
  - Particulate radiation is ionizing radiation where the ionization process is initiated by particles. Particulate radiation includes alpha, beta, and neutrons.
  - Non-particulate radiation is ionizing radiation where the ionization process is initiated by electromagnetic energy (photons). Non-particulate radiation includes gamma rays and x-rays.
- Special units are the traditional methods of measurement in the U.S. SI units are used in many other parts of the world. NRC documents now include both special unit and their SI equivalents.
  - Curies are the traditional measure of the level of radioactivity. Becquerels are the SI unit.
  - RAD is the traditional measure of the amount of radiation absorbed by any material, including human tissue. Grays are the corresponding SI unit.
  - REM is the traditional measure of the amount of dose equivalent (includes the amount of biological damage). Sievert is the corresponding SI unit.



## Key Points

- Dose limits are established by the NRC and published in 10 CFR 20. Doses are measured in RADs and REMs.
  - The RAD is the absorbed dose and refers to how much radiation the tissue has absorbed. The SI unit is the Gray. One RAD of radiation is always 1 RAD, regardless of the type of radiation.
  - The REM is the equivalent dose and refers to how much biological damage has occurred. The SI unit is the Sievert. One RAD of radiation does not always equate to one REM of damage, since REM takes into account the various types of radiation.
- There are a number of equations used in managing dose.
  - $REM = RAD \times \text{Quality factor}$
  - $Dose = \text{Dose Rate} \times \text{Time exposed}$
  - $\text{Stay Time} = \text{Dose Limit} \div \text{Dose Rate}$

- There are two types of doses: acute and chronic
  - Acute doses are characterized by short (less than an hour) exposure to high levels of ionizing radiation. They tend to kill cells in the human body, and may result in a form of Acute Radiation Syndrome (ARS).
  - Chronic doses are characterized by long-term exposure to lower levels of ionizing radiation. They tend to damage or mutate cells rather than kill them, and are more likely to result in cancer.



### Key Points

- ALARA is the commonly used acronym for **As low as reasonably achievable**. ALARA standards are published in 10 CFR 20.
- ALARA is the guiding principle regarding exposure and doses, regardless of the established dose limits. In other words, even if the dose limit is 5 REM per year, the goal of ALARA is to keep the yearly dose under 5 REM and as close to ZERO as possible.
- There are three main strategies for ALARA doses. They are:
  - Minimize time exposed to radiation
  - Maximize the distance from the radiation source
  - Maximize the shielding from the source
- Contamination and contaminated areas require protective measures to maintain ALARA doses.
- Appropriate signs should be displayed prominently in areas where radiation is known to exist. US radiation signs use a magenta (purple) radiation symbol and text against a yellow background. With international placards, the color combination can be magenta or red on yellow.



### Key Points

- The primary types of background radiation are cosmic and terrestrial. Low doses of cosmic radiation constantly bombard the Earth from the sun and the stars, and the dose decreases the farther through the atmosphere the radiation travels. Low doses of terrestrial radiation are present in the soil, water, and vegetation. People regularly ingest and inhale low levels of radioactive material that gives them chronic background dose.
- The general populace is also exposed to low doses of radiation due to the nuclear fuel cycle. NRC regulations keep these trace amounts of radioactivity relatively low.

- Nuclear workers are potentially exposed to additional radiation over the background that they and the general public receive. Sources of exposure to nuclear workers include:
  - Natural fuel decay
  - Fission process
  - Fission products
  - Activation products

# Radioactive Waste Management

## Chapter Introduction

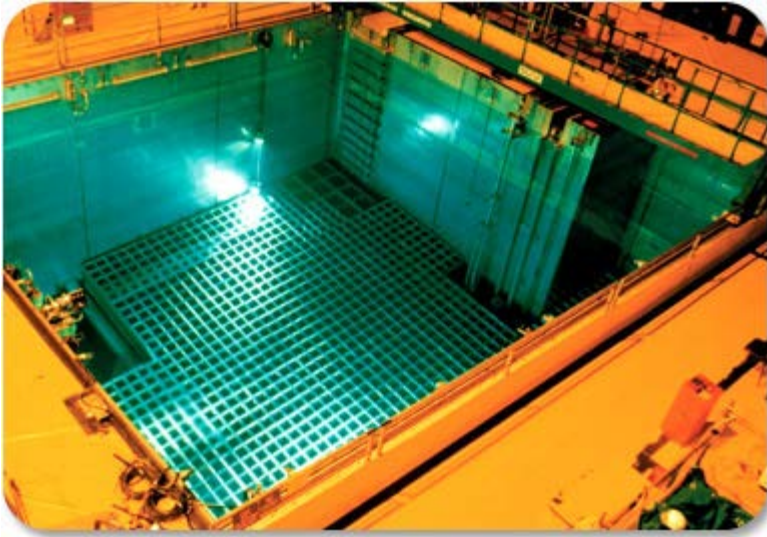

## Chapter Introduction

Radioactive waste—also referred to as radwaste—is solid, liquid, and gaseous material from nuclear operations that is radioactive, or that becomes radioactive, and is no longer needed at the plant. This section will discuss the sources, handling, and ultimate disposal of radioactive waste generated by nuclear power plant operation.

Nuclear power plants produce both low- and high-level radioactive waste. The material is either naturally occurring or man-made. Certain kinds of radioactive materials, and the wastes produced from using these materials, are subject to regulatory control by the Federal Government or the various states.

The Nuclear Regulatory Commission (NRC) and some states (known as Agreement States) regulate commercial radioactive waste created from the production of electricity and other, non-military uses of nuclear material.



## Objectives

After completing this chapter, you will be able to:

- Identify sources of radioactive waste produced in nuclear power generation.
- Identify examples of both high- and low-level radioactive waste.



- Understand the methods of processing and disposing of radioactive waste.
- Identify how the NRC classifies and regulates radioactive waste produced by nuclear reactors.

### Estimated time to complete this chapter:

25 minutes

## Low-level Radioactive Waste



### Low-level Radioactive Waste

[Radioactive](#) waste—also referred to as radwaste—is solid, liquid, and gaseous material from nuclear operations that is radioactive, or becomes radioactive, and is no longer needed at the plant. High-level waste, which we will explore later, includes spent reactor [fuel assemblies](#). Low-level radioactive waste is a secondary product of using other radioactive material.

Throughout this section we will explore sources, processing, and disposal of low-level radioactive waste.

### Low-level Radioactive Waste: Examples

Low-level radioactive waste can be either solid, liquid, or gas. Because of the different characteristics of solids, liquids, and gases, each must be processed differently. Here is a list of examples of each type:

#### Liquid:

- Equipment leak-off points
- Equipment vents and drains
- Floor drain system

#### Solid:

- Contaminated rags, tools, clothing, etc.
- Spent filter cartridges

- Spent [demineralizer](#) resins

### Gaseous:

- Equipment vents
- [Boiling Water Reactor](#) main condenser off-gas
- PWR coolant degassing

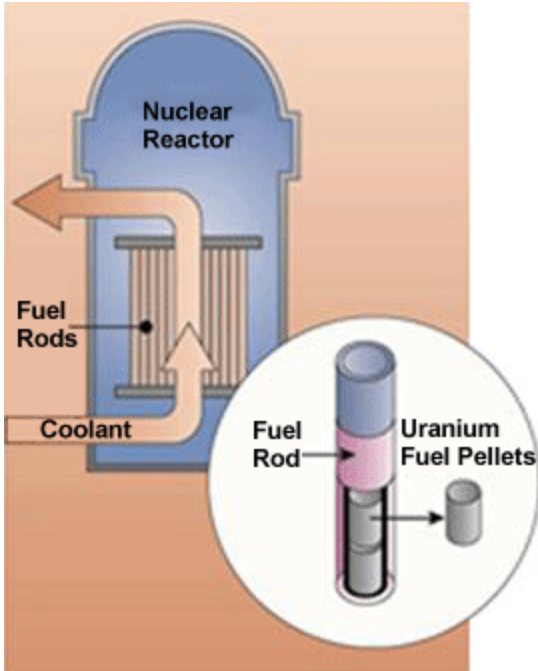

Source U.S. Nuclear Regulatory Commission

### Low-level Radioactive Waste: Sources

The principal sources of low-level radioactive waste are the reactor coolant water and the components and equipment that come in contact with the coolant. During the normal operation of a nuclear power plant, the coolant water becomes contaminated by [activation](#) products ([crud](#)) and a very small percentage of [fission products](#) that may leak out of the [fuel rods](#).

The process of removing radioactive elements from the coolant system, general housekeeping, and maintenance generates much of the low-level radioactive waste. On the next few slides we will follow the generation, processing, and disposal of this low-level radioactive waste.

Generally, the largest contributor to low-level waste is all the extraneous materials associated with operating a power reactor such as contaminated anti-C clothing, cleaning materials, broken tools and equipment, and the chemicals and reactor coolant itself.

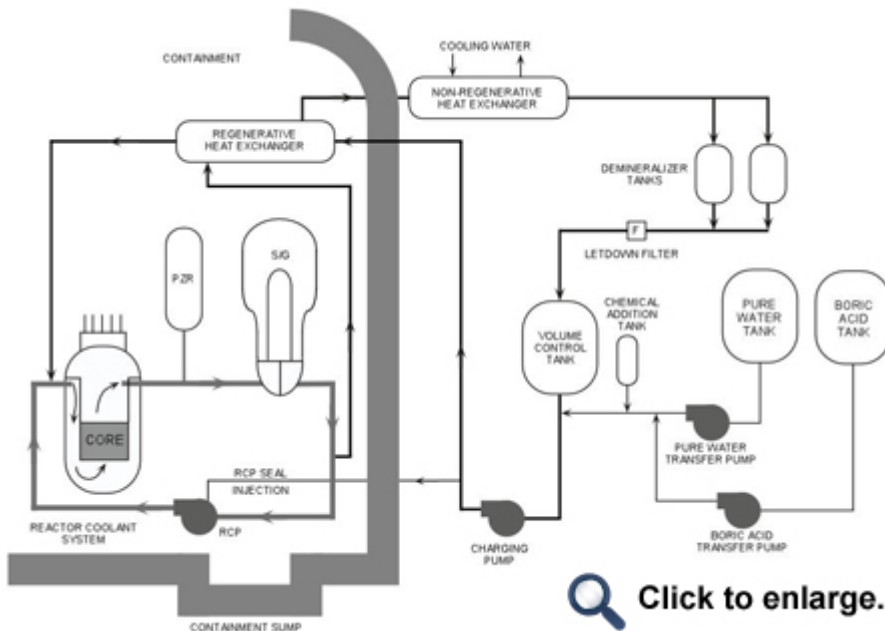

## Low-level Radioactive Waste: Sources

### Chemical and Volume Control System

The Chemical and Volume Control System (CVCS) on a [Pressurized Water Reactor](#) (PWR) is used to remove the activation and fission products from the reactor coolant.

As the reactor coolant flows through the CVCS, it passes through demineralizers and filters. The resins and filter cartridges become contaminated. After use, the resins and cartridges will be disposed of as solid radioactive waste.

In the PWR volume control tank, the reactor coolant is sprayed into a hydrogen gas bubble. As the water is sprayed, other gases are stripped out of solution. These gases can then be vented to the waste gas system to be processed as gaseous radioactive waste.

If water needs to be removed from the reactor coolant system, there is a flow path that can be lined up to divert the reactor coolant flow from the chemical and volume control system to the liquid radioactive waste system for processing and eventual disposal, or release to the environment after sufficient cleaning/decontamination.

BWR designs include a system called Reactor Water Clean-up (RWCU). This system is similar to the PWR system regarding the continuous removal of small amounts of reactor coolant that is sent through filters and demineralizers for cleaning. As with the PWR system, RWCU water can be sent to waste processing systems for disposal.

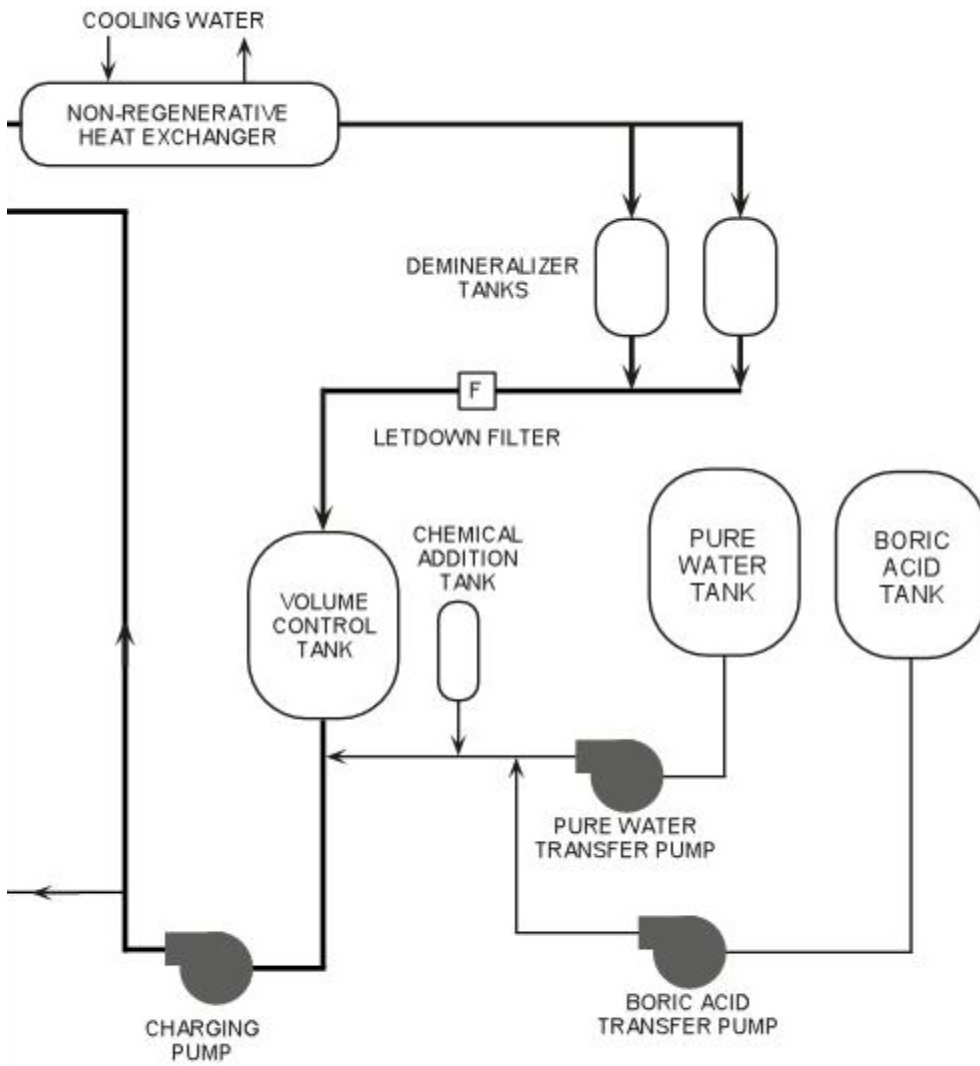

## Low-level Radioactive Waste: Sources

### Cleanups

The CVCS is only one example of how radioactive waste is generated by the operation of a power plant system. Wastes are also generated due to housekeeping and cleanup. For example if a part must be replaced, the tools, clothing, rags, and the used parts can all become contaminated.

Some general housekeeping is also necessary to contain any small leaks or spills during the normal operation of a nuclear reactor. Plant staff routinely capture any material and dispose of it properly. The material and tools (e.g., mops or rags) are now treated as low-level radioactive waste.

## Low-level Radioactive Waste: Classification

Low-level radioactive waste is classified based on the concentration and type of [radionuclides](#) involved. Federal Regulations, section 10 CFR 61.55, lists the limits on concentrations of specific radioactive materials allowed in each low-level waste class: A, B, or C. Radioactive Waste class depends on two characteristics: [dose](#) and [stability](#).

## Low-level Radioactive Waste: Classification

### Dose

The first characteristic is the dose that one could receive from the radioactive waste. This dose is dependent on two factors: concentration and the type of radioactive [isotope](#) contained in the waste. Thus, something that is in a low concentration, but is highly radioactive, is considered the same as something that is in high concentration, but low in radioactivity.

The regulation noted previously contains a table that gives specific concentrations per cubic meter of waste for the given radionuclide/isotope. Simply put, the lower the concentration or less radioactive the type, the more likely it is Class A. Conversely, the higher the concentration or more long-lived the type, the higher the potential dose and the more likely it will be classified as B or C.

## Low-level Radioactive Waste: Classification

### Stability

Stability is the ability of the radioactive waste to maintain its gross physical properties and identity over time. To avoid the migration of radionuclides, the radioactive waste is placed in its disposal site and covered. In this way, access to water, which could erode stability, is minimized. Long-term active maintenance and potential exposures to intruders can also be avoided.

Radioactive waste containing the lowest dose can be unstable, similar to ordinary household wastes. If this unstable, low level waste is mixed with the higher activity waste, the lack of stability in the low level waste component could lead to failure of the system, permitting water to penetrate the disposal unit and cause problems with the higher activity waste.

In order to achieve maximum stability, only STABLE Class A waste can be mixed with the other classes. Unstable Class A waste must be segregated at the disposal site.

Class A	Class B	Class C
97% of waste generated but only 9.7% of the total activity	2.5% of waste generated but only 24.8% of the total activity	0.5% of waste generated but only 65.5% of the total activity

## Low-level Radioactive Waste: Classification

### Class A

As explained previously, Class A waste contains the lowest level of radioactive material with a [half-life](#) of about 5 years. Due to its instability, it must be disposed of separately.

### Class B

Class B contains the next lowest concentration of radioactive materials, and it contains a higher proportion of materials with longer half lives. Class B waste must meet more rigorous requirements on waste form to ensure stability after disposal.

### Class C

Class C low-level waste has the highest concentration of radioactive material allowed to be buried in a low-level waste disposal facility. Waste that will not decay to levels that present an acceptable hazard to an intruder within 100 years is designated as Class C waste.

This waste is disposed of at a greater underground depth than the other classes of waste so that subsequent surface activities by an intruder will not disturb the waste. Class C waste must meet all of the Class B requirements and requires additional measures at the disposal facility to protect against inadvertent intrusion.

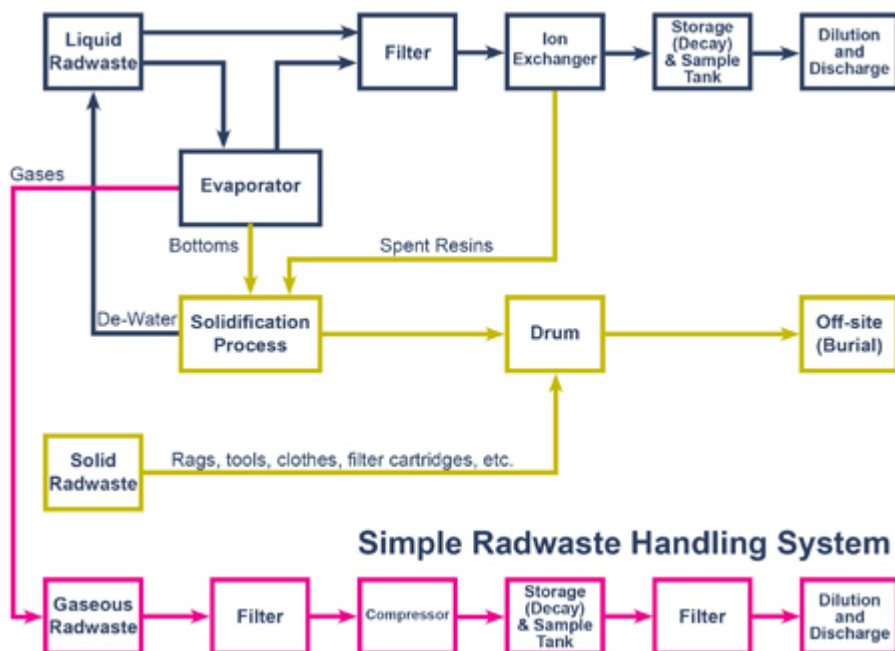

## Low-level Radioactive Waste: Handling & Processing

Because of the different characteristics of solids, liquids, and gases each must be processed differently. The waste must also be processed in such a manner as to minimize the risk of public exposure. In the next few slides we will explore how the physical properties of radioactive waste dictate the methods for handling, processing, and disposal.

## Low-level Radioactive Waste: Handling & Processing

### Liquid Radioactive Waste

Liquids are processed to remove the radioactive impurities. These processes might include:

- Filtering
- Routing through demineralizers
- Boiling off the water (evaporation) and leaving the solid impurities, which are then processed as solid radioactive waste
- Storing the liquid for a time period to allow the radioactive material to [decay](#)

After processing the water will be sampled. If samples show the water meets the required standards, the water can be placed in the storage tanks for use in the plant or it can be released to the environment. If the samples show the water does not meet the standards, it will be reprocessed.

## Low-level Radioactive Waste: Handling & Processing

### Solid Radioactive Waste

Loose solid radioactive waste (e.g., solids remaining after water has been evaporated) will be mixed with a hardener, such as concrete, to form a solid. This is sometimes done with spent demineralizer resins. After mixing with a hardener, the material is processed as solid radioactive waste. Solid wastes are packaged as required and shipped to a burial site for disposal.

## Low-level Radioactive Waste: Handling & Processing

### Gaseous Radioactive Waste

Gaseous wastes are filtered, compressed to take up less space, and then allowed to decay. After the required time has passed, the gases will be sampled. If the required limits are met, the gases will be released to the atmosphere or sometimes the gases will be reused in specific areas of the plant.

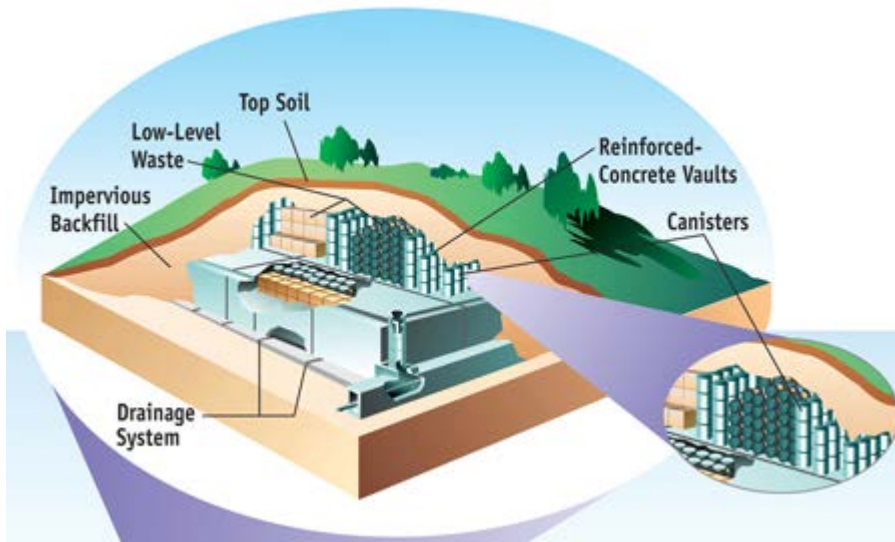

## Low-level Radioactive Waste: Disposal

The proper disposal of radioactive waste will help minimize the dose received by the public. Currently, low-level radioactive waste is all that is accepted for disposal at burial sites.

Low-level waste disposal occurs at commercially operated low-level waste disposal facilities that must be licensed by either NRC or Agreement States. The facilities must be designed, constructed, and operated to meet safety standards. The operator of the facility must also extensively characterize the site on which the facility is located and analyze how the facility will perform for thousands of years into the future.

There are three disposal sites presently operating:

- Barnwell, South Carolina, accepts all low-level waste from the Atlantic Compact only (limited number of states/licensees).
- Hanford, Washington, can accept waste from the Northwest and Rocky Mountain compacts.
- EnergySolutions in Clive, Utah, is authorized to accept only Class A (low-activity/high-volume) waste from all states.

Originally, these three disposal sites were accepting waste from the entire US. The Low-Level Waste Policy Act of 1980 gave each state the responsibility for managing and disposing its own low-level radioactive waste, to be implemented by 1986. This act was amended in 1985 to allow an extension until 1993, and allowed states to enter into compacts with other states to utilize a common disposal site. The Act also divided the United States (U.S.) into these regional low-level waste compacts. Each compact has a host state that will contain the low-level waste disposal site. Some compacts have more than one host state.



## Check Your Knowledge



- **Which of the following are involved in the processing, handling, and disposal of low-level radioactive waste?**

Select all that apply, then select Done.

1. Forty one of the fifty states accepts low-level waste for burial.
  2. correct:Radioactive waste can be released to the environment after processing.
  3. correct:Loose solid radioactive waste can be mixed with a hardener to improve stability.
  4. correct:Radioactive waste class depends on two characteristics: dose and stability.
  5. Waste that will not decay to levels that present an acceptable hazard within 10 years is designated as Class C waste.
- Correct. Low-level radioactive waste classification is based on potential dose and stability. Radioactive waste can be released to the environment after processing if it meets specific standards. Loose solid radioactive waste may be mixed with a hardener to improve stability.
  - Incorrect. Class C waste will not decay to acceptable levels in 100 years. There are three disposal sites currently operating. Low-level radioactive waste classification is based on potential dose and stability. Radioactive waste can be released to the environment after processing if it meets specific standards. Loose solid radioactive waste can be mixed with a hardener to improve stability.

## High-level Radioactive Waste

### High-level Radioactive Waste

Disposal of high-level radioactive waste is the responsibility of the Department of Energy. The licensing of high-level waste disposal facilities is the responsibility of the USNRC, as specified in 10 CFR Part 60, “Disposal of High-Level Radioactive Waste in Geologic Repositories.”

As with low-level radioactive waste, high-level waste must be processed and disposed of properly. In this section we will explore the current processing and storage of high-level radioactive waste from nuclear reactors, the proposed high-level radioactive waste disposal site at Yucca Mountain, and current temporary storage solutions.

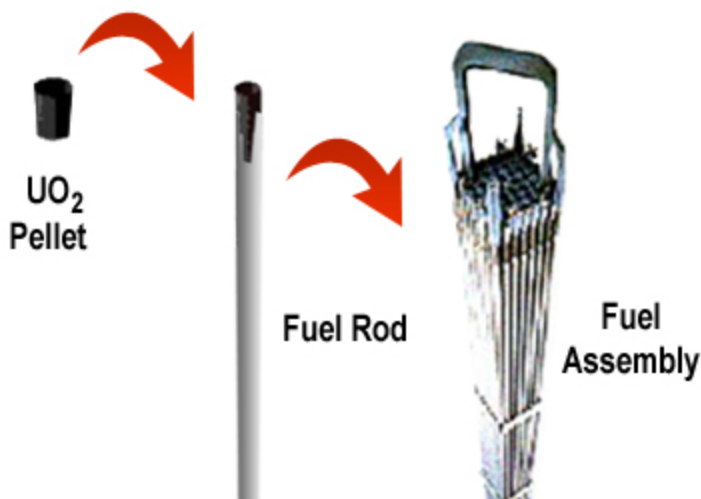

### High-level Radioactive Waste: Sources

[Spent fuel](#) is classified as high-level radioactive waste. This is due to the buildup of very highly radioactive [fission](#) products as the fuel is used in the reactor. After a [fuel assembly](#) has been used in the reactor core to generate power, there is a large inventory of fission products held inside the cladding of the fuel. Since the

processing of spent fuel is not done in the U.S. for commercial power plants, the fuel must be disposed of in some safe fashion.



## High-level Radioactive Waste: Handling & Processing

### Fuel Pool

When the spent fuel is removed from the reactor to be replaced with new fuel, it must be stored for a period of time in the [spent fuel pool](#). The spent fuel must be kept under water due to the heat being generated by the decay of the fission products and to limit the radiation levels in the immediate area.

The spent fuel pools are usually located onsite. However, due to the amount of fuel some power plants have accumulated during their operations, the licensee may also have had to build an Interim Spent Fuel Storage Installation (ISFSI) onsite. These ISFSI facilities store the spent fuel in a dry condition, in robust containers, and can be licensed under the plant's Part 50 license, or separately under Part 72.



## High-level Radioactive Waste: Handling & Processing

### Dry Storage

After several years, the heat generated by the decay of the fission products decreases sufficiently to allow the storage of the spent fuel in an air-cooled, dry, above-ground storage facility. These facilities must be designed to remove the heat from the spent fuel and limit radiation exposure to the areas around the facilities. Some licensees have constructed dry cask storage facilities. These dry fuel storage facilities must be licensed by the NRC. This licensing can be achieved under the plant's Part 50 license, or under a separate Part 72 license.

Some of these casks have been designed with the idea of using them to ultimately transport the fuel to a permanent facility (e.g., Yucca Mountain) when it is licensed and built. However, the design requirements for these shipping casks need to be approved.

## High-level Radioactive Waste: Disposal

High-level radioactive waste is not currently being accepted for burial. Nuclear power plants were originally designed with spent fuel pools to temporarily store fuel assemblies that had reached the usable end of their life. The fuel would then be transferred to either a fuel reprocessing facility or a long-term storage facility under the auspices of the Federal Government.

However, the government determined that reprocessing would not occur and the significant delay in licensing and building the fuel repository (Yucca Mountain) resulted in nuclear utilities' spent pools becoming full. As discussed on the previous page, many licensees have constructed licensed dry storage facilities for their spent fuel.

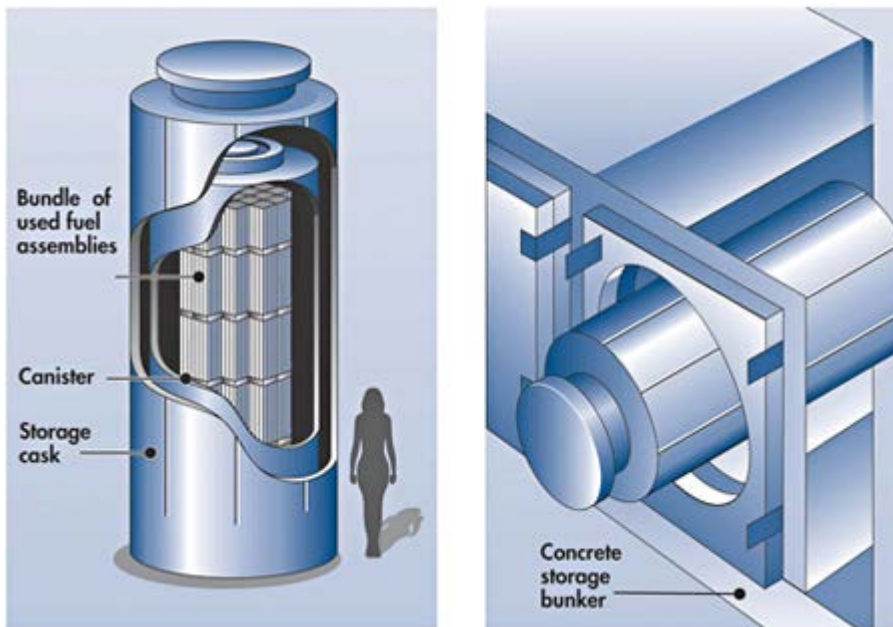

## High-level Radioactive Waste: Disposal

### Dry Cask Long-term Storage

In response to this, many utilities have extended the licensing and construction of dry fuel storage facilities as a long-term storage solution. These independent spent fuel storage installations (ISFSI) come in different designs, but all utilize natural air flow for cooling. These facilities have separate licenses from those governing the operation of the power plant. The facilities are a temporary fix to the ultimate disposal of spent fuel.

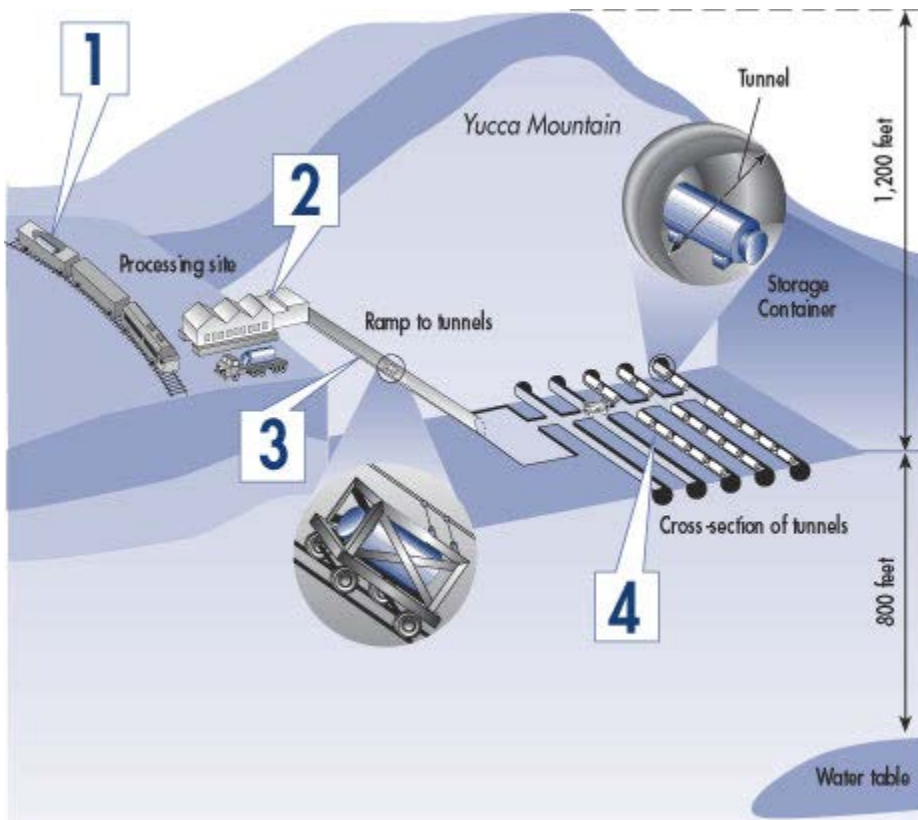

Canisters of waste, sealed in special casks, are shipped to the site by truck or train.

Shipping casks are removed, and the inner tube with the waste is placed in a steel, multilayered storage container.

An automated system sends storage containers underground to the tunnels.

Containers are stored along the tunnels, on their side.

## High-level Radioactive Waste: Disposal

### Yucca Mountain

Even though there is not presently a high-level waste repository accepting spent fuel for disposal, the Nuclear Waste Policy Act of 1982, as amended, directed the Department of Energy to site, design, construct, and operate a high-level waste repository.

The proposed site for the high-level repository is Yucca Mountain, Nevada. The site will resemble a mining complex. On the surface will be the waste handling facilities. About 1000 feet below the surface will be the disposal site for the containerized waste. The image to the right illustrates the Yucca Mountain concept.

## High-level Radioactive Waste: Disposal

The Environment Protection Agency (EPA) has published its final regulations for the site. They can be found in 40 CFR Part 197, “Environmental Radiation Protection Standards for Yucca Mountain.” The regulations limit the dose to the public to 15 mrem/year from the facility. The regulations also impose an additional groundwater protection dose limit of 4 mrem/year from beta and photon-emitting radionuclides.

The Department of Energy has submitted the application for Yucca Mountain and the licensing process is ongoing.



## Check Your Knowledge

- **What are the current challenges related to high-level radioactive waste processing and disposal?**  
Select all that apply, then select Done.
  1. correct:High-level radioactive waste is not currently being accepted for burial.
  2. correct:The significant delay in licensing and building the fuel repository (Yucca Mountain) resulted in nuclear utilities' spent pools becoming full.
  3. correct:Newer spent fuel must be kept under water due to heat decay.
  4. There is a significant lack of storage space for above-ground dry casks.
  5. Nuclear power plants were originally designed with high-level processing and disposal onsite.
- Correct. High-level radioactive waste is not currently being accepted for burial. The significant delay in licensing and building the fuel repository (Yucca Mountain) resulted in nuclear utilities' spent pools becoming full. When the spent fuel is initially removed from the reactor to be replaced with new fuel, it must be stored for a period of years in the spent fuel pool for cooling.
- Incorrect. High-level radioactive waste is not currently being accepted for burial. The significant delay in licensing and building the fuel repository (Yucca Mountain) resulted in nuclear utilities' spent pools becoming full. When the spent fuel is initially removed from the reactor to be replaced with new fuel, it must be stored for a period of years in the spent fuel pool to be cooled.

## Chapter Summary



## Key Points of Low-level Radioactive Waste

- Radioactive waste, is solid, liquid, and gaseous material from nuclear operations that is radioactive, or has become radioactive, and is no longer needed at the plant.
- Low-level radioactive waste can be either solid, liquid, or gas. Each type must be processed differently.
  - Gaseous wastes are filtered, compressed, allowed to decay, and then release safely.
  - Loose solid radioactive waste will be mixed with a hardener to improve stability.
  - Liquid waste is either filtered, demineralized, evaporated, or allowed to decay.



## Key Points of Low-level Radioactive Waste (continued)

- The principal sources of low-level radioactive waste are the reactor coolant water and the components and equipment that come in contact with the coolant.
  - The CVCS on a PWR is used to remove the activation and fission products from the reactor coolant. The RWCU system in a BWR does the same thing. These processes generate low-level radioactive waste.
  - During routine housekeeping, plant staff routinely capture any material and dispose of it properly.
- Radioactive waste classification depends on two characteristics:
  - **dose** – the concentration and type of radioactive isotope contained in, or emitted from, the waste
  - **stability** - the ability of the radioactive waste to maintain its gross physical properties and identity over time
- Low-level radioactive waste is buried at designated facilities to limit exposure to the public.



## Key Points of High-level Radioactive Waste

- Disposal of high-level radioactive waste is the responsibility of the Department of Energy.
- Spent fuel is classified as high-level radioactive waste due to the buildup of highly radioactive fission products.
  - Spent fuel must be stored for a period of time in the spent fuel pool to absorb decay heat and to confine emitted radiation.

- After several years, the fuel decays sufficiently to allow the storage in an air-cooled, dry, above-ground storage facility.



### **Key Points of High-level Radioactive Waste (continued)**

- High-level radioactive waste is not currently being accepted for burial.
  - In response to this, many utilities have implemented the licensing and construction of dry fuel storage facilities as a long-term storage solution.
- The Nuclear Waste Policy Act of 1982, as amended, directed the Department of Energy to site, design, construct, and operate a high-level waste repository.
  - The proposed site for the high-level repository is Yucca Mountain, Nevada.
  - The Department of Energy has submitted the application for Yucca Mountain and the licensing process is ongoing.

# Transportation of Radioactive Material

## Chapter Introduction



## Chapter Overview

About 3 million packages of radioactive material (RAM) are shipped each year in the United States (U.S.) either by road, rail, air, or water. This represents less than 1 percent of the Nation's yearly hazardous material shipments. Oversight of the safety of commercial RAM shipments is the joint responsibility of the NRC and the U.S. Department of Transportation (DOT).

The vast majority of these shipments consist of small amounts of RAM used in industry, research, and medicine. The NRC requires such materials to be shipped in accordance with DOT's hazardous materials transportation safety regulations.

The basic principle regarding transport of RAM is to either restrict the type and activity of the contents OR provide accident-proof packaging. This chapter will discuss the NRC's shared oversight of the transportation of RAM in the U.S. with the DOT.

## Basic Premise

Fundamental to a good understanding of radioactive material transportation safety and packaging requirements is the basic premise that:

*Safety in transporting radioactive material primarily depends upon the use of the proper packaging for the type, quantity, and form of the radioactive material to be transported. In addition, packaging design is performance oriented, with the packaging integrity being dictated by the hazards of the radioactive content.*

Put more simply, proper packaging is the primary means of providing safety, and contents which present higher hazards are to be contained in stronger packagings.

## United Nations Hazardous Materials Classifications

### UN Classifications

All hazardous materials that could potentially be transported are assigned to one of the nine UN Classes. In general, the hazardous materials listed pose an **immediate threat to health and safety**.



Move the tab along the slider bar for information about the different UN Classes.

For non-sighted users, please use these skip links to get to the items on the slider.

- [Class 1](#)
- [Class 2](#)
- [Class 3](#)
- [Class 4](#)
- [Class 5](#)
- [Class 6](#)
- [Class 7](#)
- [Class 8](#)
- [Class 9](#)



## Class 1

Explosives are classified as Class 1 hazardous materials.



## Class 2

Gases are classified as Class 2 hazardous materials. They can be flammable, non-flammable, poisonous, asphyxiants, and/or oxygen.



## Class 3

Flammable liquids are classified as Class 3 hazardous materials.



## Class 4

Flammable solids are classified as Class 4 hazardous materials.

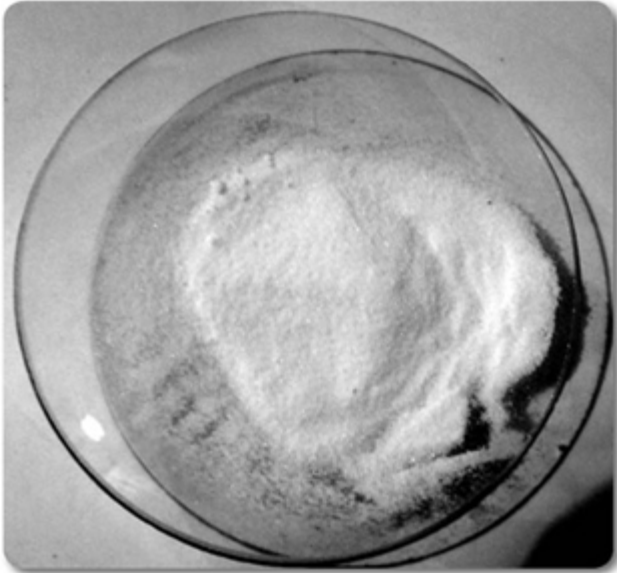

### **Class 5**

Oxidizers and organic peroxides are classified as Class 5 hazardous materials.



### **Class 6**

Poisonous and etiological materials are classified as Class 6 hazardous materials.



### **Class 7**

Radioactive materials are classified as Class 7 hazardous materials. With Class 7 (RAM), the threat is potentially the non-immediate risk of cancer, although in large enough quantities radiation can pose an immediate threat to health.



### **Class 8**

Corrosives are classified as Class 8 hazardous materials.



## Class 9

Miscellaneous hazardous materials are classified as Class 9 hazardous materials.



## Class 7

All hazardous materials that could potentially be transported are assigned to one of the nine (9) UN classes, as we discussed previously. In general, the hazardous materials listed pose an immediate threat to health and safety. However, for RAM the threat is potentially the non-immediate risk of cancer, although in large enough quantities radiation can pose an immediate threat.

Since transport accidents cannot be prevented, the regulations are primarily designed to:

- Ensure safety in routine handling situations for minimally hazardous material

- Ensure integrity under all circumstances for highly dangerous materials

These goals are accomplished by focusing on the package and its ability to:

- Contain the material (prevent leaks)
- Prevent unusual occurrences (such as criticality)
- Reduce external radiation to safe levels (provide shielding)



## Check Your Knowledge

- **Which items describe UN Class 7 materials?**

Select all that apply, then select Done.

1. correct:Radioactive.
  2. correct:Materials may pose the non-immediate risk of cancer.
  3. Corrosive.
  4. Materials pose no threat.
- Correct. UN Class 7 hazardous materials are classified as radioactive. With Class 7 materials the threat is potentially the non-immediate risk of cancer, although in large enough quantities radiation can pose an immediate threat.
  - Incorrect. UN Class 7 hazardous materials are classified as radioactive. Class 7 materials are not classified as corrosive. Radioactive materials are harmful and dangerous. With Class 7 materials the threat is potentially the non-immediate risk of cancer. However in large enough quantities, radiation can pose an immediate threat.

## NRC and DOT Responsibilities



## Licensing and Inspection

The NRC conducts about 1,000 transportation safety inspections of fuel, reactor, and materials licensees annually.

The NRC reviews, evaluates, and certifies approximately 80 new, renewal, or amended package design applications for the transport of nuclear materials annually.

The NRC inspects about 20 dry storage and transport package [licensees](#) annually.

The NRC reviews and evaluates approximately 150 license applications for the import or export of nuclear materials annually.



### DOT Reg 49 CFR

The NRC and DOT share responsibility for the control of RAM transport based on a Memorandum of Understanding (MOU).

In general, DOT regulations (49 CFR) are more detailed. They cover all aspects of transportation including packaging, shipper and carrier responsibilities, documentation, and all levels of RAM from exempt quantities to very high levels.



### NRC Reg 10 CFR 71

The NRC regulations (10 CFR 71) are primarily concerned with special packaging requirements for higher level quantities. NRC regulation 10 CFR 71.5 requires NRC licensees transporting RAM to comply with DOT regulations in those situations where NRC regulations do not apply.



## Check Your Knowledge

### Which items identify the different types of transportation regulations?

Enter the number from the Answer Options in the corresponding field, then select Done.

Answers Options:

1-Reg 49 CFR      2-Reg 10 CFR 71

- Implemented by the NRC.
- Implemented by the DOT.
- This regulation covers all aspects of transportation.
- This regulation is primarily concerned with special packaging requirements.

## Packages



### Transport Packages

Annually, about twenty million packages of all sizes containing RAM are routinely transported worldwide on public roads, railways and ships. These packages are transported using various types of robust and secure containers. There has never been any accident in which a container with **highly** radioactive material has been breached or has leaked.

When transporting hazardous material, packaging is used to store and ship the materials. (Packaging is the container alone, a package is the container AND the material together)



We will discuss four of the types of RAM packagings (there are more depending on the type of material being shipped):

- Excepted
- Industrial
- Type A
- Type B



## Excepted Packaging

Excepted Packaging is designed to survive **normal** conditions of transport. They are generally used for shipping of materials that contain very low levels of radioactivity and/or dose rates. They include radioactive instruments or articles, articles manufactured from natural or depleted uranium or natural thorium, and empty packages.

Excepted packaging can be almost any type of container that meets the basic requirements, with any of the above contents. They are accepted from several labeling and documentation requirements, but must at least bear the letters UN and the four digit UN iD number.



## Industrial Packaging

Industrial Packagings (IP) are designed to survive normal conditions of transport (IP-1) and at least the DROP test and stacking test for Type A packaging (IP-2 and IP-3). Industrial packagings (IP) are used for transportation of materials with small amounts of radioactivity (Low Specific Activity [LSA] or Surface Contaminated Objects [SCO]).

Industrial packagings (IP) are usually metal boxes or drums.

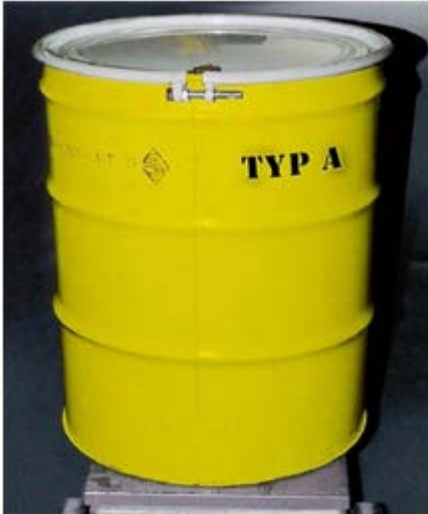

### Type A Packaging

Type A packaging is designed to survive normal transportation, handling, and minor accidents. They are used for the transportation of limited quantities of radioactive material (RAM) that would not result in significant health effects if they were released. There are two levels of Type A packaging that differentiate between material that can, or cannot, be dispersed easily if the container is breached.

Type A packaging may be cardboard boxes, wooden crates, or drums. The shipper and carrier must have documentation of the certification of the packages being transported.

## Shipping Requirements

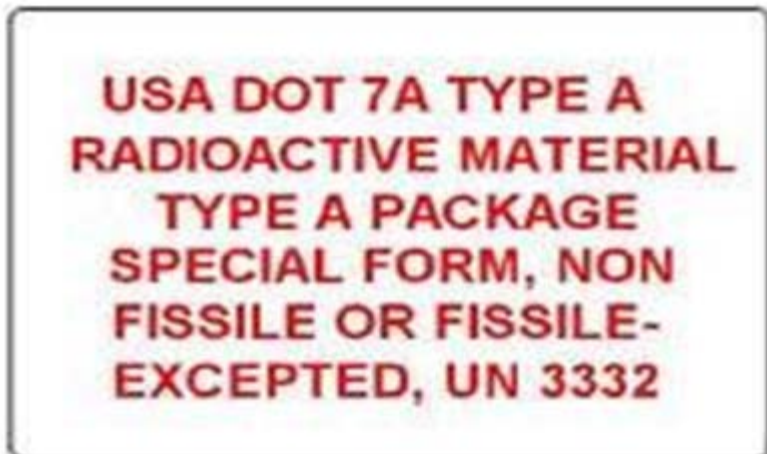

### Markings

Federal regulations require that shippers meet marking and labeling requirements for packages containing radioactive materials. Markings are designed to provide an explanation of the contents of the package with the proper shipping name, emergency response identification number, and other standard terms and codes.

## Labels

Labels identify the contents of the package and the level of radioactivity. There are three types of radioactive shipping labels and the packages must be marked correspondingly. Shipments with extremely low levels of radioactivity that do not present a hazard are accepted from labeling requirements. Labels are used to visually indicate the type and level of hazard contained in a package. Labels rely principally on symbols to indicate the hazard.

Although the package required for transporting RAM is based on the activity inside the package, the label required on the package is based on the radiation hazard outside the package. RAM is the only hazardous material that has three possible labels, depending on the relative radiation levels external to the package. The information is a number called the Transport Index (TI), which is the highest radiation level at 1 meter from the surface of the package.



## Placards

Placards are just bigger labels that are placed on the outside of the vehicle. Unlike labels, there is only one placard and no information needs to be written on it (i.e., no Transport Index). In general, placards on a vehicle are only required if the vehicle is carrying at least packages of low specific activity material, but they **must** have a placard if the TI is a III).

If the amount of material being transported constitutes a highway route controlled quantity, the diamond-shaped placard has a black square border surrounding it.

**SHIPPING PLACARD FOR RADIOACTIVE MATERIALS**  
 This placard is to be placed on the outside of the vehicle in a conspicuous location.  
 Use both sides.

1. SHIPPER'S NAME (in English and Spanish)  
 2. DATE OF PREPARATION (in English and Spanish)  
 3. NATURE AND QUANTITY OF CONTENT (in English and Spanish)  
 4. PACKAGE INFORMATION (in English and Spanish)  
 5. SIGNATURE OF THE SHIPPER (in English and Spanish)

NATURE AND QUANTITY OF CONTENT				PACKAGE INFORMATION			
SHIPPER'S NAME FOR USE	DATE OF PREPARATION	CLASSIFICATION	ACTIVITY	DATE OF PREPARATION	TYPE OF PACKAGE	CLASSIFICATION	ACTIVITY

ADDITIONAL INFORMATION REQUIRED FOR TYPE B MATERIAL ONLY

1. SHIPPER'S NAME (in English and Spanish)  
 2. DATE OF PREPARATION (in English and Spanish)  
 3. NATURE AND QUANTITY OF CONTENT (in English and Spanish)  
 4. PACKAGE INFORMATION (in English and Spanish)  
 5. SIGNATURE OF THE SHIPPER (in English and Spanish)

DATE: \_\_\_\_\_ SIGNATURE OF THE SHIPPER (see IAEA/HQ above): \_\_\_\_\_

SHIPPER'S NO.: \_\_\_\_\_ ADDRESS: \_\_\_\_\_

## Shipping Papers

The only way for anyone to know what is being transported inside a vehicle is by reviewing the shipping papers. These documents, by words and codes, clearly specify what is being transported. They must be readily accessible to the driver and to emergency response personnel if the driver is not available.



## Check Your Knowledge

**Which items identify the different types of markings?**

Enter the number from the Answer Options in the corresponding field, then select Done.

## Answers Options:

1-Labels      2-Placards      3-Shipping Papers

- These are the only way to identify the contents inside a vehicle.
- These are placed on the outside of the vehicle.
- These are used to indicate the type of hazard and the level of hazard within a package.
- These markings are based on the radiation hazard outside the package.

## Chapter Summary



### Key Points

- The UN has nine classifications of hazardous material used in potential transport; Class 7 refers to RAM.
- Class 7 materials pose a potential threat with the non-immediate risk of cancer; and in large enough quantities, radiation can pose an immediate threat.
- Different types of containers and packages are used for transportation. The following were discussed:
  - Excepted and Industrial packages are designed to survive normal transportation handling.
  - Strong tight containers are designed to survive normal transportation handling.
  - Type A containers are designed to survive normal transportation handling and minor accidents.
  - Type B containers must be able to survive severe accidents, and are usually issued a Certificate of Compliance by the NRC.
- Markings are designed to provide an explanation of the contents of a package.



## **Key Points**

- Labels are used to visually indicate the type and level of hazard contained in a package.
- Placards are bigger labels that are placed on the outside of the vehicle.
- Shipping papers are used to identify what is being transported inside a vehicle.

# Refueling Operations

## Chapter Introduction



## Chapter Overview

A reactor core is designed to operate at its full power output for some period; usually 12, 18, or 24 months. After this time period, the reactor must undergo refueling operations. During refueling, a portion of the core will be replaced with fresh fuel, and the remaining older fuel will be repositioned. The amount of the core replaced with new fuel during the refueling outage will depend on the projected core lifetime.

This chapter will describe some of the basic activities involved in the refueling process for a Westinghouse pressurized water reactor (PWR). The refueling methods and activities of other types of reactors (both CE/B&W PWRs and GE BWRs) are similar.



## Objectives

At the end of this chapter, you will be able to:

- Identify the major components and their functions for refueling operations.
- Sequence the basic steps in refueling a nuclear power plant.

## Estimated time to complete this chapter:

35 minutes

## Refueling Components



### New Fuel

Long before the actual refueling process takes place, plans are made for the refueling outage. The new fuel is ordered, manpower considerations are taken into account, and any other known maintenance is scheduled during the outage. Some period of time before the refueling is to occur, the new fuel is received onsite. The new fuel will be inspected and then stored in the new fuel storage area.

The new fuel storage area is a dry storage vault in the fuel handling building. Dry storage is sufficient because the fuel has not been used for power production. Therefore, there are insufficient levels of fission products to generate heat and the radiation levels around the fuel are only slightly above background levels.

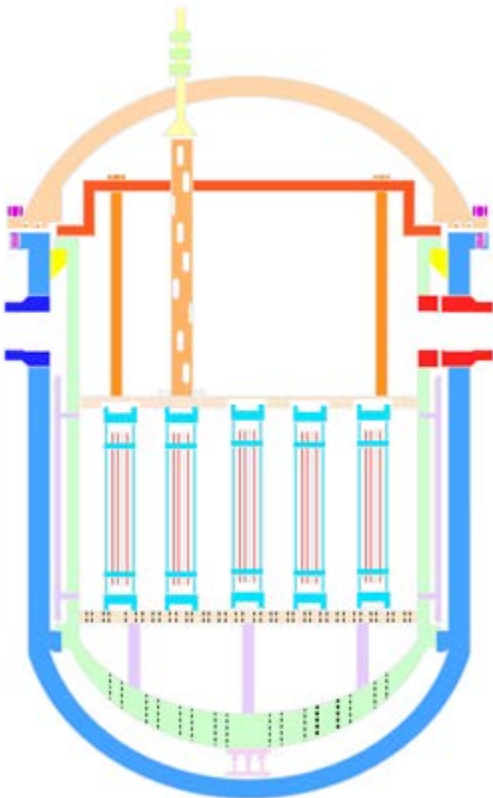



## Vessel Disassembly

When it is time to perform the refueling, the reactor is shutdown and the plant is cooled down. This is necessary to allow access to the vessel area and to allow its disassembly. At this time, the fuel handling equipment will be tested to ensure proper operation.

After the plant is cooled down and depressurized, disassembly of the reactor will commence. First, all cables, ventilation ducts, cable trays, and insulation are removed. Then, a seal must be installed between the reactor vessel and the reactor cavity wall since the cavity over the open vessel will be filled with water. The seal will prevent any water from leaking out of the vessel cavity area. Many plants now leave this seal in place all the time (saves time/money/dose).

To transfer the fuel back and forth from the containment building/fuel building, the fuel transfer tube is opened up. This is done by removing a blind flange (solid cover) from the end of the transfer tube in the containment building. After the refueling cavity is flooded, a valve is opened in the fuel building to open the transfer path between the spent fuel and the refueling pools.

The studs that hold the vessel head on the reactor vessel are now removed. Guide studs are installed to provide alignment when moving the head and vessel internals. Except for the guide studs, the remaining stud holes are plugged to protect the threads from the borated water (PWR). The vessel head is moved to a dry storage area inside the containment. To move the head, and other heavy components (e.g., RCP motors), there is an overhead crane installed inside the containment building, called the polar crane.

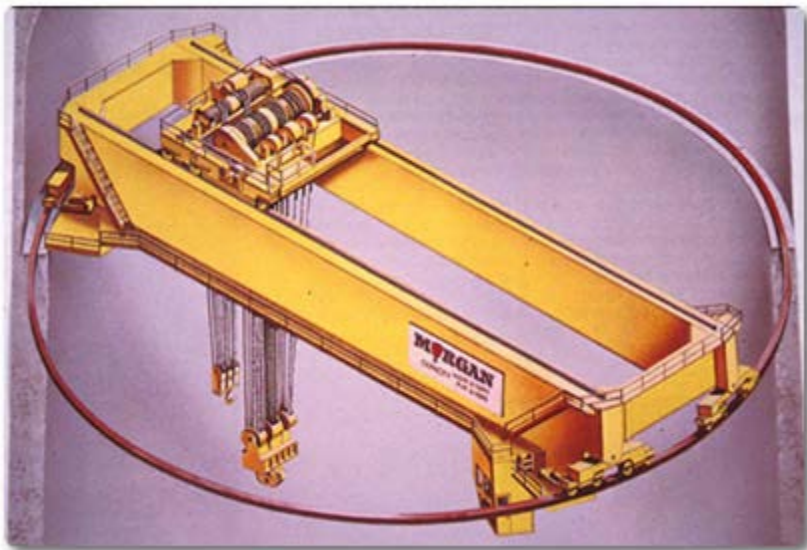

## Polar Crane

High in the containment building is a polar crane strong enough to lift the vessel head (100+ tons). The crane can also move in such a fashion as to reach virtually any part of the containment building for other movable equipment (e.g., reactor coolant pumps, valves, etc.)

Prior to removing the reactor vessel head, operators will cool the plant down (to about 100°F) and depressurize it to atmospheric pressure. The vessel head is held in place by about 56 large bolts, called studs. Mechanics will utilize hydraulic tensioners to elongate the studs in order to loosen and tighten the nuts holding the head in place. The studs and nuts are then each removed as one unit.



## Check Your Knowledge

- **Which items describe the events that take place prior to the refueling outage process?**  
Select all that apply, then select Done.
  1. correct: Manpower considerations are taken into account.
  2. correct: New fuel is ordered well in advance of the refueling outage.
  3. The reactor refueling cavity is flooded immediately after shutting the reactor down.
  4. correct: Maintenance performed during the outage is scheduled.
- Correct. Long before the actual refueling process takes place, plans are made for the refueling outage. The new fuel is ordered, manpower considerations are taken into account, and any other known maintenance is performed during the time that the outage is scheduled.
- Incorrect. Long before the actual refueling process takes place, plans are made for the refueling outage. The new fuel is ordered, manpower considerations are taken into account, and any other known maintenance is performed during the time that the outage is scheduled.

## Refueling Process



### Lifting The Vessel Head

The reactor vessel head is lifted and set down on a special stand within the containment building. During this time, most personnel are evacuated from the containment building for reasons of industrial and radiological safety (i.e., falling loads and high airborne radioactivity from underneath the head).

When set down, the underside of the vessel head is heavily shielded, but can be inspected by robotic machines looking for weld cracking and corrosion. The outside of the head may be contaminated, but the underside will be highly radioactive due to its proximity to the core.

All other components of the reactor assembly (fuel assemblies, upper guide structure, core shroud) inside the vessel will be kept underwater at all times due to their extremely high levels of radioactivity.

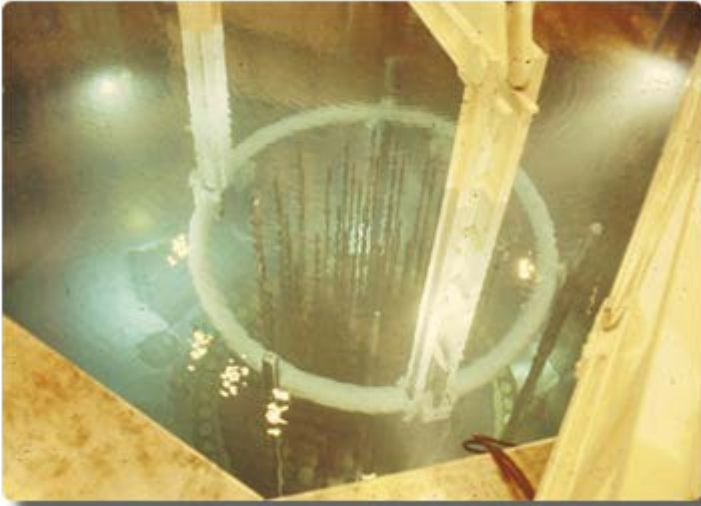

## Flooding

The flooding of the refueling cavity commences after the vessel head is lifted. The cavity is flooded by pumping water from the refueling water storage tank through the residual heat removal pumps and into the reactor coolant system where it will enter the reactor vessel and overflow into the cavity. The water level will be increased to a minimum of approximately 25 feet above the reactor vessel flange.

After the cavity is flooded, the upper core internals are removed. Prior to the internals removal, the control rod drive shafts must be disconnected from the control rods (to prevent pulling the control rods out of the fuel when the upper internals are pulled). The shafts are disconnected and the upper internals package is removed and stored underwater. Fuel movement/shuffling may now commence.

## Fuel Transfer

Before a new fuel assembly can be placed into the core, an old assembly must be removed. Once an old assembly has been moved, a new fuel assembly can now be sent to the reactor. Because of the high radioactive levels of spent fuel, all fuel movements are conducted under water for shielding.

Move the tab along the slider bar for information about the transferring of spent fuel in the reactor.

For non-sighted users, please use these skip links to get to the items on the slider.

- [Manipulator Crane](#)
- [Conveyor Car](#)

- [Upender](#)
- [Fuel Transfer Tube](#)
- [Second Upender](#)
- [Spent Fuel Bridge Crane](#)

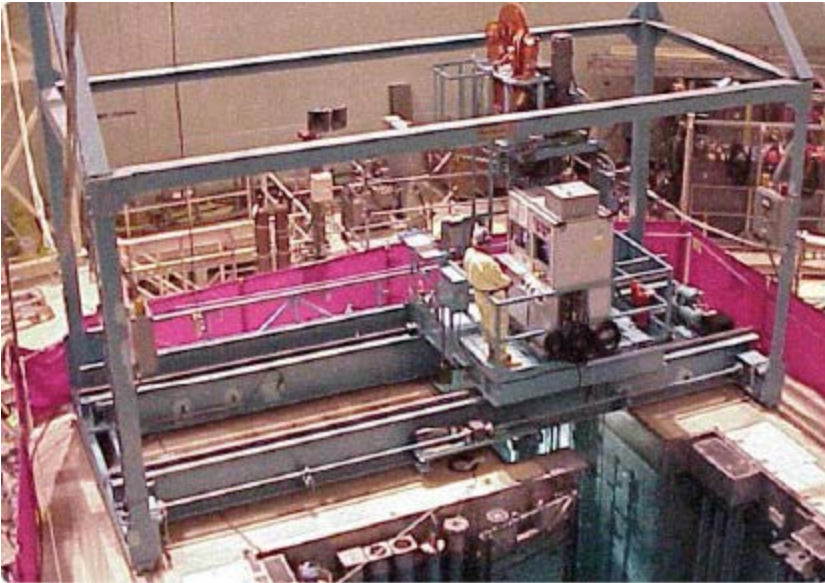

### **Manipulator Crane**

The manipulator crane, or refueling machine, is used to move fuel. The manipulator crane will take the fuel to the control rod change fixture or to the area where it can be transferred to the spent fuel pool in the fuel building.

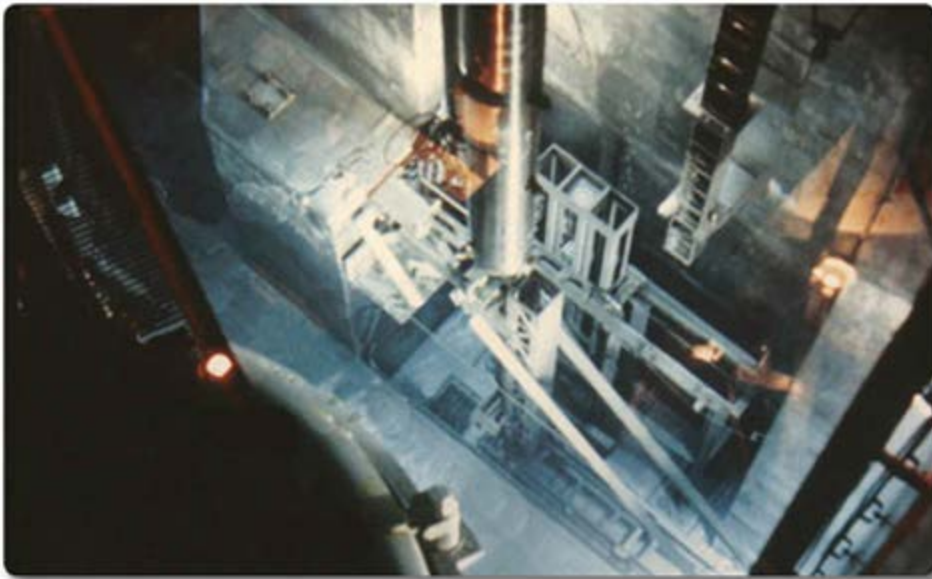

### **Conveyor Car/Fuel Carriage**

The fuel assembly is placed into the conveyor car assembly, which is made vertical or horizontal by a hydraulic upender. The conveyor car is used to transport the fuel assembly to and from the fuel handling building and the containment building, through the refueling tube/tunnel.



### Upender

The upender is used to lower the conveyor car from the vertical to the horizontal position. This must be done to move the conveyor car and fuel assembly through the fuel transfer tube.



### Fuel Transfer Tube

The fuel assembly is transferred through the fuel transfer tube. This tube is the path for the fuel to penetrate through the containment wall.



### Second Upender

A second upender in the fuel handling building will raise the conveyor car back to the vertical position. The two upenders are virtually identical.

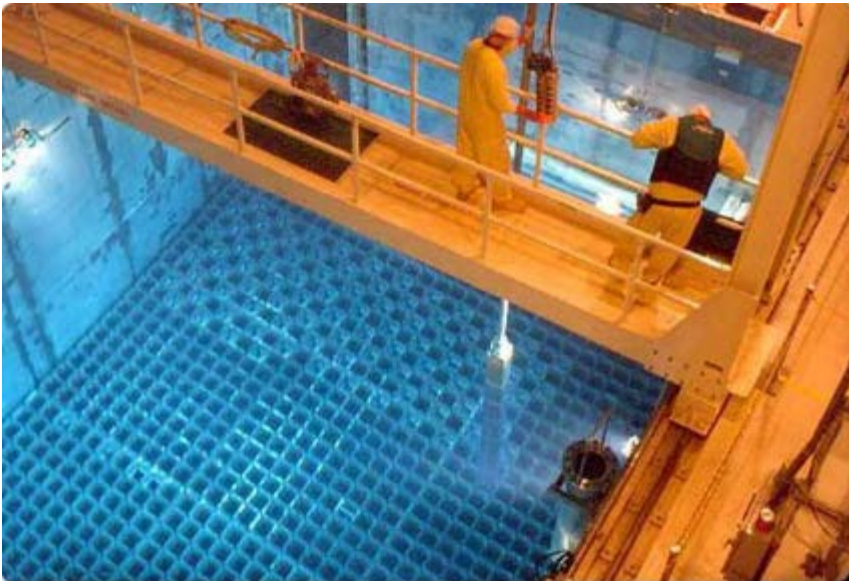

### Spent Fuel Bridge Crane

The spent fuel pool bridge crane is used to move the fuel assemblies from the conveyor car in the upender to a storage location in the pool. It will then pick up a new fuel assembly that is temporarily stored in the spent fuel pool, and send it into the containment to be inserted in the reactor.



## New Fuel Transfer

In order for a new fuel assembly to be transferred to the containment building, it is placed into the spent fuel pool using the fuel building crane and the new fuel elevator. From the fuel pool, the spent fuel bridge crane will take the assembly and place it into the conveyor car on the upender. The upender will lower the conveyor car and fuel assembly to the horizontal position. From this position, the new fuel is sent through the fuel transfer tube to the containment building. The upender in the containment building will raise the fuel assembly and conveyor car to the vertical position, where the manipulator crane will pick up the fuel assembly and transfer it to its proper position in the core. The movement of fuel will continue until all fuel assemblies are in their proper location. After the completion of the fuel shuffle, a record is made of all fuel assemblies and their location in the core.

A refueling outage may last 2 months or more due to maintenance work. However, the fuel shuffling process usually takes less than 1 week.

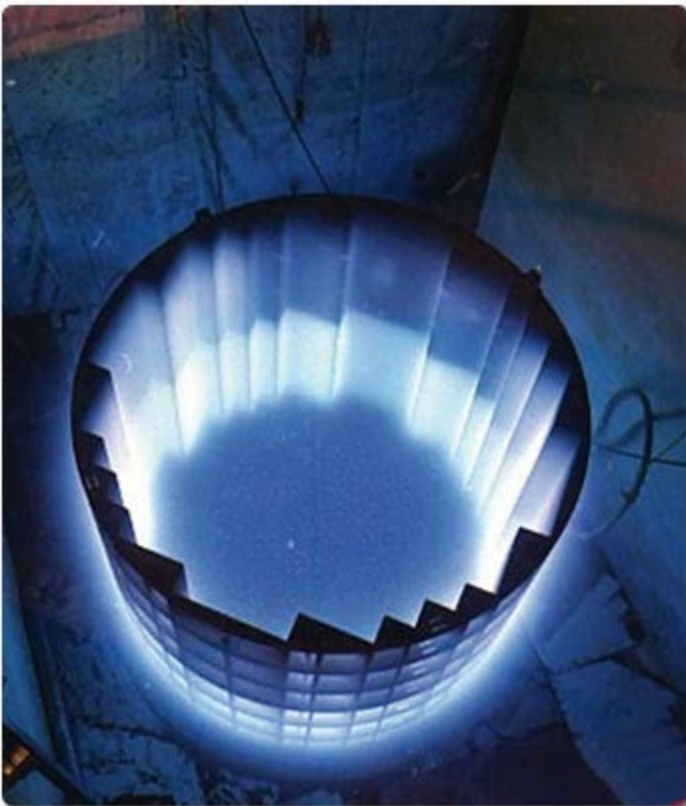

## Full Core Offload

Some plants perform a full core offload instead of a fuel shuffle. A fuel core offload is where all of the fuel is removed from the reactor vessel and placed in the spent fuel pool. In the spent fuel pool, special tools are used to transfer any fuel assembly inserts (control rods, thimble plugs, etc.) to new fuel assemblies. One major advantage of a full core offload is that several Technical Specifications do not have to be met, which means that plant personnel can work on many safety systems in parallel.

Full offloads would be required if the plant needed to inspect the reactor vessel or core barrel. The picture to the right is a core shroud after it has been removed from the reactor vessel. It is kept underwater due to its high level of radioactivity (note the blue glow from certain radiation effects).

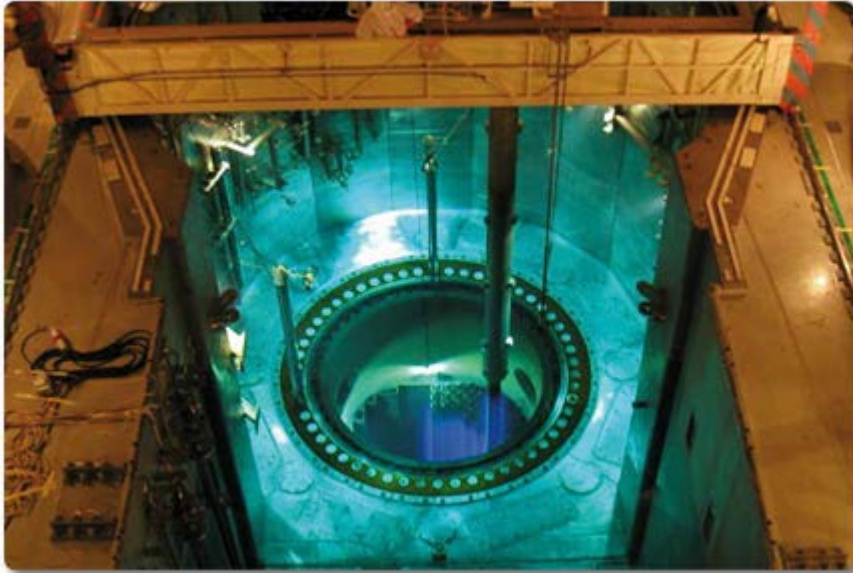

## Reconnection

Once the operators are finished with the fuel shuffle/replacement, the upper internals are replaced over the core. The operators will then reconnect the control rod drive shafts.

The refueling pool will be drained and the reactor vessel head will be replaced and bolted down. The containment area will be decontaminated to the extent possible and all extraneous material and equipment will be removed.

Operators will conduct testing of plant protective equipment and systems to ensure that they can operate effectively for the upcoming fuel cycle. They will heat up and repressurize the plant, then take the reactor critical and begin the power operation cycle all over.



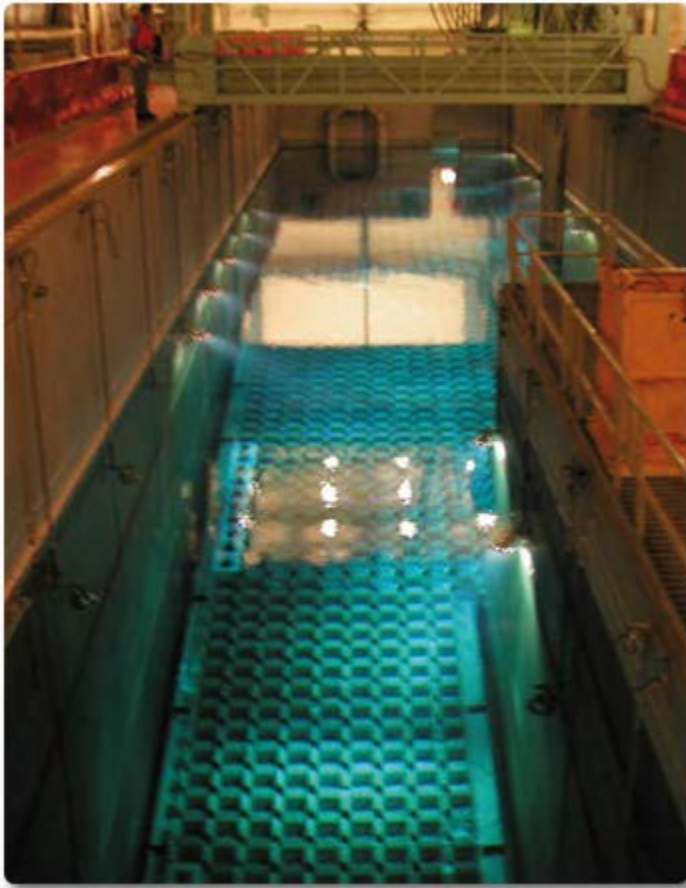

## Spent (Exhausted) Fuel

The exhausted fuel that was removed from the core during the outage will be stored in the spent fuel pool. This spent fuel will continue to produce a significant amount of decay heat for many years to come.

Since the spent fuel continues to produce heat, the spent fuel has a cooling system. If cooling to the spent fuel is lost for an appreciable amount of time, it is possible for the pool water to heat up to the point where it will boil. For this reason, the spent fuel pool and its support systems are safety related. They have emergency power, redundant systems, and are seismically qualified.

Many utilities have begun building dry fuel storage facilities because their spent fuel pools have become full. Spent fuel that has been stored in the Spent Fuel Pool for at least a year can be removed and placed in heavy-duty, stainless steel cylinders, filled with inert gas, that are stored in a dry condition in a separate location at the plant. These storage areas are known as Independent Spent Fuel Storage Installations. These interim storage facilities can be licensed under either the existing Part 50 license for the plant, or a separate Part 72 license, depending on the design. The low levels of decay heat remaining in these dry-stored canisters are removed by natural circulation of air around the containers.

There are approximately 54 separate ISFSI sites in 33 states in the US at present. Until the final repository for high level waste (spent fuel) is built and operational, it is expected that the number of ISFSI sites will increase.



## Check Your Knowledge

- **Which items describe the events that take place when moving spent fuel?**

Select all that apply, then select Done.

1. correct: A manipulator crane moves the spent fuel onto an upender.
  2. correct: Spent fuel is moved between containment areas using the fuel transfer tube.
  3. Containment areas are deflooded.
  4. correct: The spent fuel bridge crane moves the spent fuel into its storage position.
- Correct. Spent fuel is moved using the manipulator crane. After the first upender moves the fuel to a horizontal position, it is transferred through the fuel transfer tube. A second upender moves the fuel into a vertical position where the spent fuel bridge crane moves it into position.
  - Incorrect. Spent fuel is moved using the manipulator crane. After the first upender moves the fuel to a horizontal position, it is transferred through the fuel transfer tube. A second upender moves the fuel into a vertical position where the spent fuel bridge crane moves it into position.

## Chapter Summary



### Key Points

- Before the actual refueling process takes place, plans are made for the refueling outage.
- After the plant is cooled down and depressurized, the reactor is disassembled.
- A polar crane is used to lift the vessel head.
- The vessel head is lifted and set down on a special stand where it is inspected.
- The refueling cavity is flooded to shield personnel from the extreme radioactivity of the core and components inside the vessel.



## Key Points

- The reactor vessel head is lifted and set down on a special stand within the containment.
- The flooding of the refueling cavity commences after the vessel head is lifted. The water level will be increased to a minimum of approximately 25 feet above the reactor vessel flange.
- Spent fuel is moved using the manipulator crane. After the first upender moves the fuel to a horizontal position, it is transferred through the fuel transfer tube. A second upender moves the fuel into a vertical position where the spent fuel bridge crane moves it into position.
- New fuel is transferred to the containment area by placing it into the spent fuel pool using the fuel building crane and the new fuel elevator. From the fuel pool, the spent fuel bridge crane will take the assembly and place it into the conveyor car. On the upender, the fuel is shifted horizontally and transferred through the fuel transfer tube.
- Plants may perform a full core offload instead of a fuel shuffle, depending on work requirements.
- After the fuel shuffle/replacement, the upper internals are replaced over the core and the control rod drive shafts are reconnected.
- The exhausted fuel is stored in the spent fuel pool, where it continues to produce heat.

# Emergency Plan Event Classifications

## Chapter Introduction



## Chapter Overview

The NRC requires any licensee of a production or utilization facility to have emergency plans in place to manage Emergency Planning and Preparedness. These plans are governed by 10CFR50, Appendix E.

These plans are required to contain the following content:

- Organization
- Assessment Actions
- Activation of Emergency Organization
- Notification Procedures
- Emergency Facilities and Equipment
- Training
- Maintaining Emergency Preparedness
- Recovery

The emergency plan event classifications were established to provide prompt notification to the proper authorities of both minor and major events. Licensees determine which emergency class to declare, based on Emergency Action Levels (EAL) contained within their emergency plan. Depending on the severity of the event, the actions taken could range from notifying the NRC to the staffing of the emergency response facilities and the notifying of local, state, and federal agencies.

The following chapter will describe the event classifications in ascending order and the purpose of each condition.



## Objectives

At the end of this chapter, you will be able to:

- Rank the four emergency classifications in ascending order of severity.
- Describe the four emergency classifications.

**Estimated time to complete this chapter:**

25 minutes

## Ranked Emergency Plan Event Classifications

### Ranking

An Emergency Classification is a condition that indicates a level of risk to the public. Each operating nuclear power plant is required to include in its emergency plans a standard Emergency Classification and Emergency Action Level (EAL) scheme. An EAL is a pre-determined, site-specific, observable threshold for a plant condition that places the plant in a given emergency classification.

The vast majority of events reported to the NRC are routine in nature and do not require activation of our incident response program. The Emergency Operations Center is continuously manned and is prepared to activate the NRC's incident response plan as needed.

Both nuclear power plants and research and test reactors use the four emergency classifications listed below in order of increasing severity.

For non-sighted users, please use these skip links to access the items on the slider.

- [Unusual Notification of Unusual Event](#)
- [Alert](#)
- [Site area emergency](#)
- [General emergency](#)

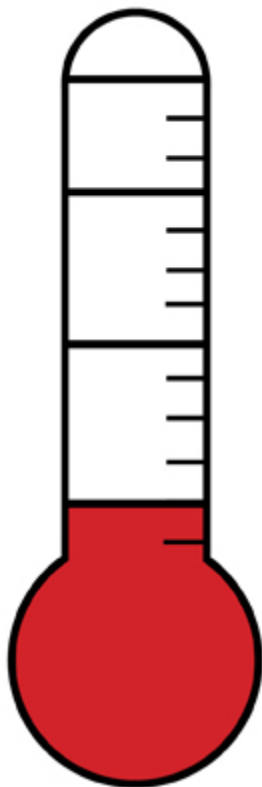

**Notification of Unusual event**

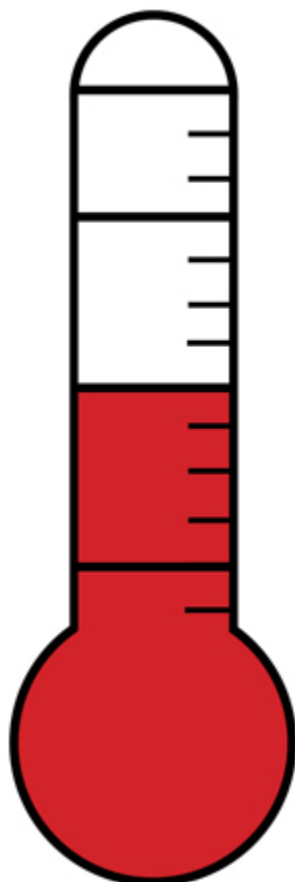

**Alert**

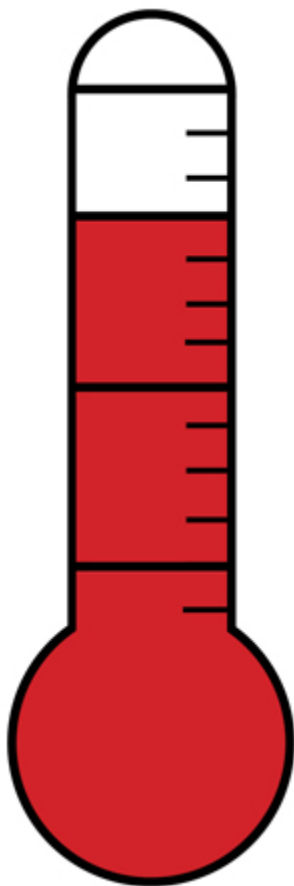

**Site area emergency**

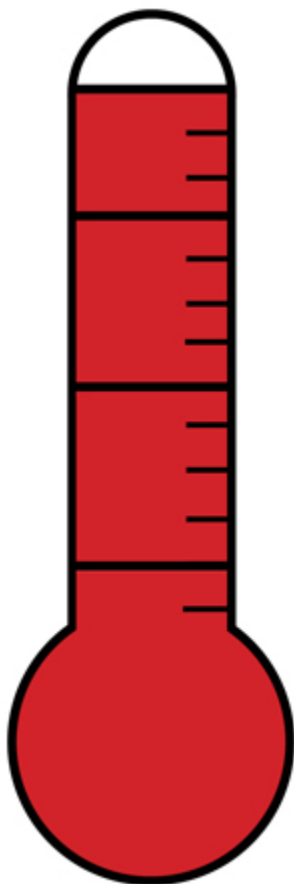

## General emergency



### Check Your Knowledge

**What is the correct order for the four EALs?**

Enter numbers (1 for the lowest through 4 for highest) in the correct order, then select Done.

- Site Area Emergency
- Unusual Event
- Alert
- General Emergency

### Description of Emergency Class

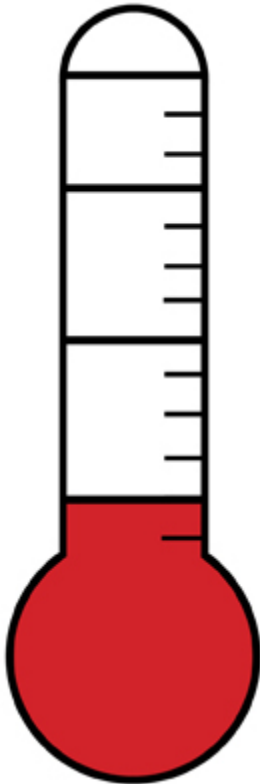

### Notification of Unusual Event (NOUE)



Under this category, events are in process or have occurred that indicate potential degradation in the level of safety of the plant. The EAL Guidance has the primary threshold for Unusual Events as operation outside the safety envelope of the plant, as defined in its Technical Specifications (license requirements for operating).

No release of radioactive material requiring offsite response or monitoring is expected unless further degradation occurs. Some reasons to initiate a NOUE might be an earthquake felt onsite or a security threat.

The reasons for use of this emergency classification are to:

- Assure that the first step in any response later found to be necessary has been carried out
- Bring the operating staff to a state of readiness
- Provide systematic handling of NOUE notification and decision making

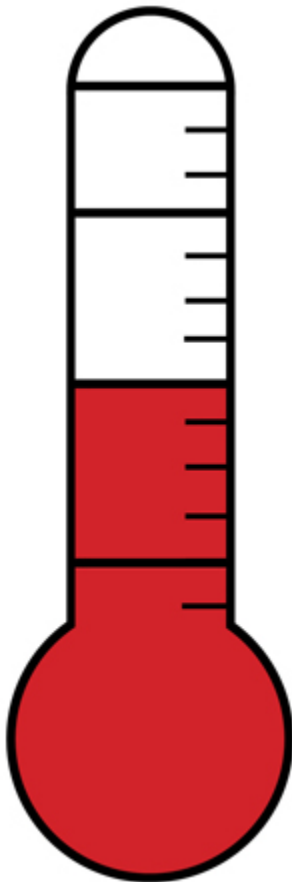

## Alert

If an Alert is declared, events are in process or have occurred that involve an actual or potential substantial degradation in the level of safety of the plant. Any releases of radioactive material from the plant are expected to be limited to a small fraction of the Environmental Protection Agency (EPA) protective action guides (PAG). Examples of initial conditions causing an Alert are fuel handling accidents or excessive primary leakage. An Alert generally denotes a condition where one of the three barriers to fission product release is, or may be, compromised (fuel cladding, reactor coolant system, containment).

The reasons for use of this emergency classification are to:

- Assure that emergency personnel are readily available to respond if the situation warrants
- Perform confirmatory radiation monitoring if required

- Provide offsite agencies with current information

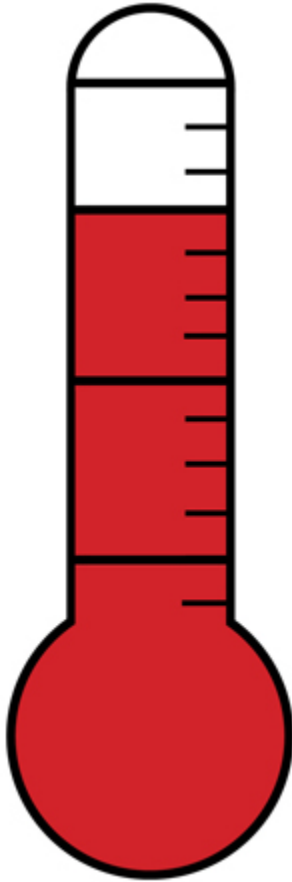

## Site Area Emergency

A Site Area Emergency involves events in process or events that have occurred that result in actual or likely major failures of plant functions needed for protection of the public. Any releases of radioactive materials are not expected to exceed the EPA protective action guides except near the site boundary. Some reasons for a licensee to declare a Site Area Emergency are a station blackout or loss of DC power for greater than 15 minutes in duration.

The declaration of a Site Area Emergency will:

- Assure that appropriate response centers are manned
- Assure that monitoring teams are dispatched
- Assure that personnel required for evacuation of near-site areas are available if needed
- Provide consultation with offsite authorities
- Provide updates to the public through offsite authorities

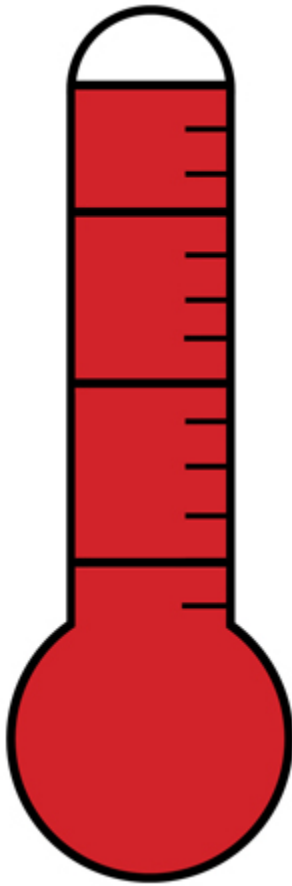

## General Emergency

A General Emergency involves actual or imminent substantial core damage or melting of reactor fuel with the potential for loss of containment integrity. Radioactive releases during a General Emergency can reasonably be expected to exceed the EPA protective action guides for more than the immediate site area. Some reasons to initiate a General Emergency are a loss of fuel cladding and reactor coolant system with a high potential for loss of containment, or a loss of coolant accident with failure of the emergency core cooling systems to perform adequately.

The key difference between a General Emergency and Site Area Emergency is whether or not exposure levels to the radioactive release plume will exceed EPA limits. A General Emergency is the only Action Level that will potentially result in evacuation of the public.

The reasons for use of the General Emergency are to:

- Be prepared to initiate predetermined protective action recommendations (PAR) for the public
  - Licensees recommend PARs
  - NRC confirms/refutes reasonableness of recommendation
  - State or local government initiates the PAR
- Provide continuous dose assessment based upon available information
- Initiate additional measures as indicated by actual or potential releases
- Provide consultation with offsite authorities
- Provide updates for the public through offsite authorities



## Check Your Knowledge

- **Which items describe an unusual event?**

Select all that apply, then select Done.

1. correct: An event indicating potential degradation in the level of safety of the plant.
  2. The unusual release of radioactive material into the air.
  3. Declaration of an alert.
  4. correct: No release of radioactive material requiring offsite response or monitoring is expected unless further degradation occurs.
- Correct. Unusual events indicate a possible degradation of plant safety. However, unless the degradation escalates, no offsite response is necessary since there is no release of radioactive material.
  - Incorrect. Unusual events indicate a possible degradation of plant safety. However, unless the degradation escalates, no offsite response is necessary since there is no release of radioactive material.



## Check Your Knowledge

- **Which items describe a Site Area Emergency?**

Select all that apply, then select Done.

1. correct: An event where the result is actual or likely major failures of plant functions needed for protection of the public.
  2. An event indicating potential degradation in the level of safety of the plant.
  3. correct: Radioactive materials released are not expected to exceed EPA protective guidelines.
  4. No release of radioactive material requiring offsite response or monitoring is expected unless further degradation occurs.
- Correct. A Site Area Emergency involves events in process or events that have occurred resulting in actual or likely major failures of plant functions needed for protection of the public. Any releases of radioactive material are not expected to exceed the EPA protective action guides except near the site boundary.
  - Incorrect. A Site Area Emergency involves events in process or events that have occurred resulting in actual or likely major failures of plant functions needed for protection of the public. Any releases of radioactive material are not expected to exceed the EPA protective action guides except near the site boundary.

# Chapter Summary

# The Three Mile Island Accident

## Chapter Introduction



## Chapter Overview

On March 24, 1978 the worst accident in the history of United States (U.S.) commercial nuclear power occurred at the Three Mile Island (TMI) Nuclear Power Plant. This watershed event caused many changes in the U.S. nuclear power industry and the NRC. Some of the key changes include:

- Placement of on-site NRC resident inspectors at each operating nuclear power plant
- Improved operator training programs
- Improved main control room panel designs
- New system-based emergency operating procedures

In this chapter, we will examine the events that eventually led to the partial meltdown of the Unit-2 core. We will consider what happened inside this [pressurized water reactor](#) (PWR) and how that resulted in the release of fission products to the surrounding environment.



## Location of Three Mile Island

TMI is located in south central Pennsylvania. It is approximately 10 miles east of Harrisburg, PA, and 100 miles west of Philadelphia, PA. The power generating station is located on, and named for, Three Mile Island on the Susquehanna River.

Unit 2 is located on the western-most end of the island, while Unit 1 is located on the eastern end. Unit 1 continues to provide power today, while Unit 2 has been shut down and partially dismantled.



## Objectives

After completing this chapter, you will be able to:

- Describe the Three Mile Island accident.
- Identify the precipitating event that caused the accident at Three Mile Island Unit 2.
- Sequence the basic events that led to the meltdown of the Three Mile Island Unit 2 core.
- Describe the release of core fission products to the environment.

**Estimated Time to Complete This Chapter:** 35 minutes

## Inside the Reactor System

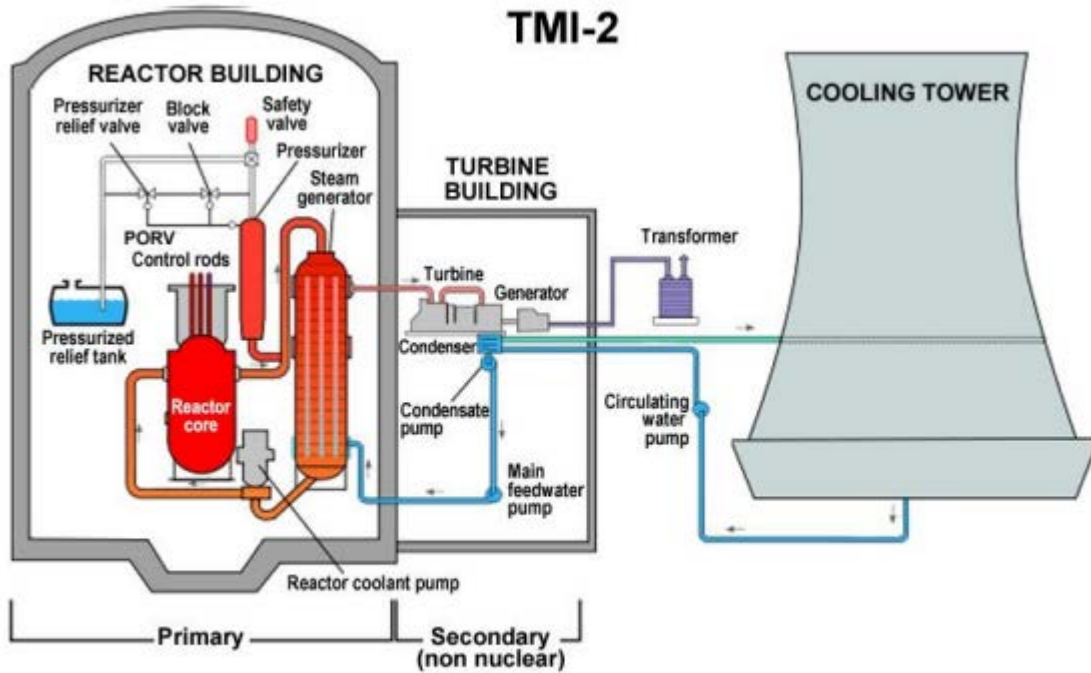

 Click to enlarge.

## Design of TMI

TMI is a two-unit PWR of the [Babcock & Wilcox design](#). The reactor coolant system consists of the reactor vessel, two steam generators, four reactor coolant pumps, and the pressurizer. Each unit functions independently and is served by two cooling towers.

Like all U.S. reactors, TMI was designed for safety and to automatically shut down in the event of [loss of coolant accident](#) (LOCA). Unfortunately, the safety measures did not address all of the possible initiating events that might cause a LOCA.

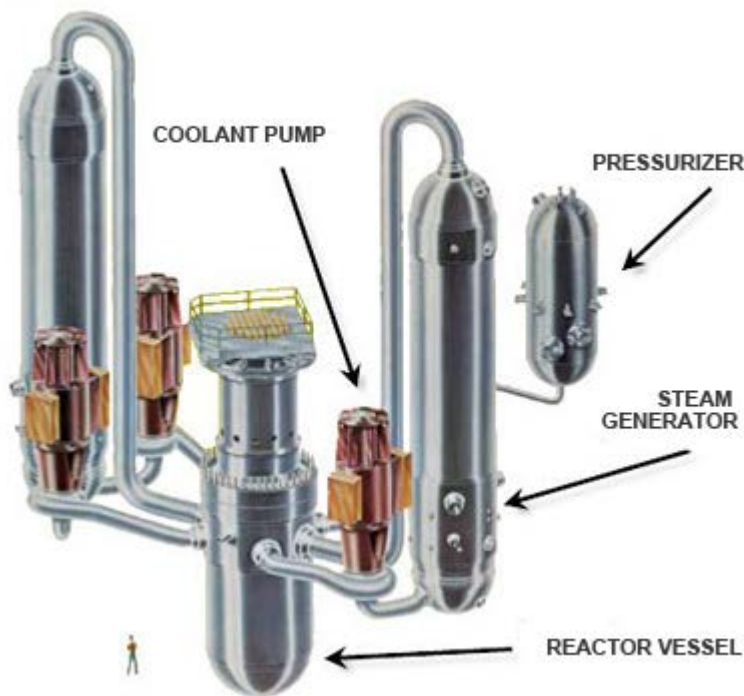



A Babcock & Wilcox pressurized water reactor has two, once-through steam generators; four reactor coolant pumps; and a pressurizer.

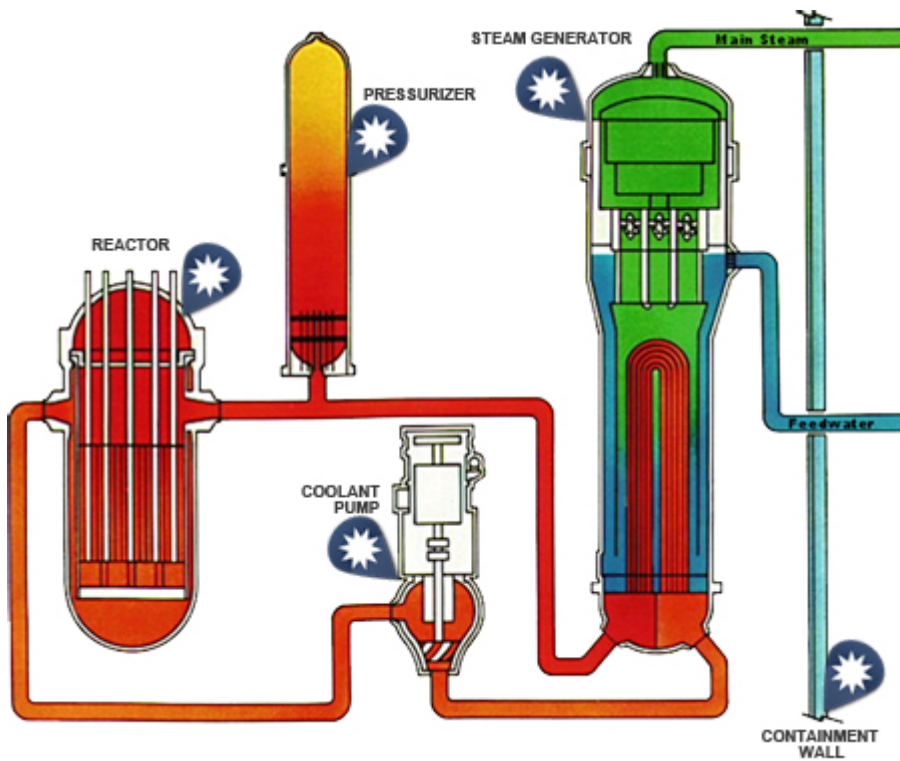
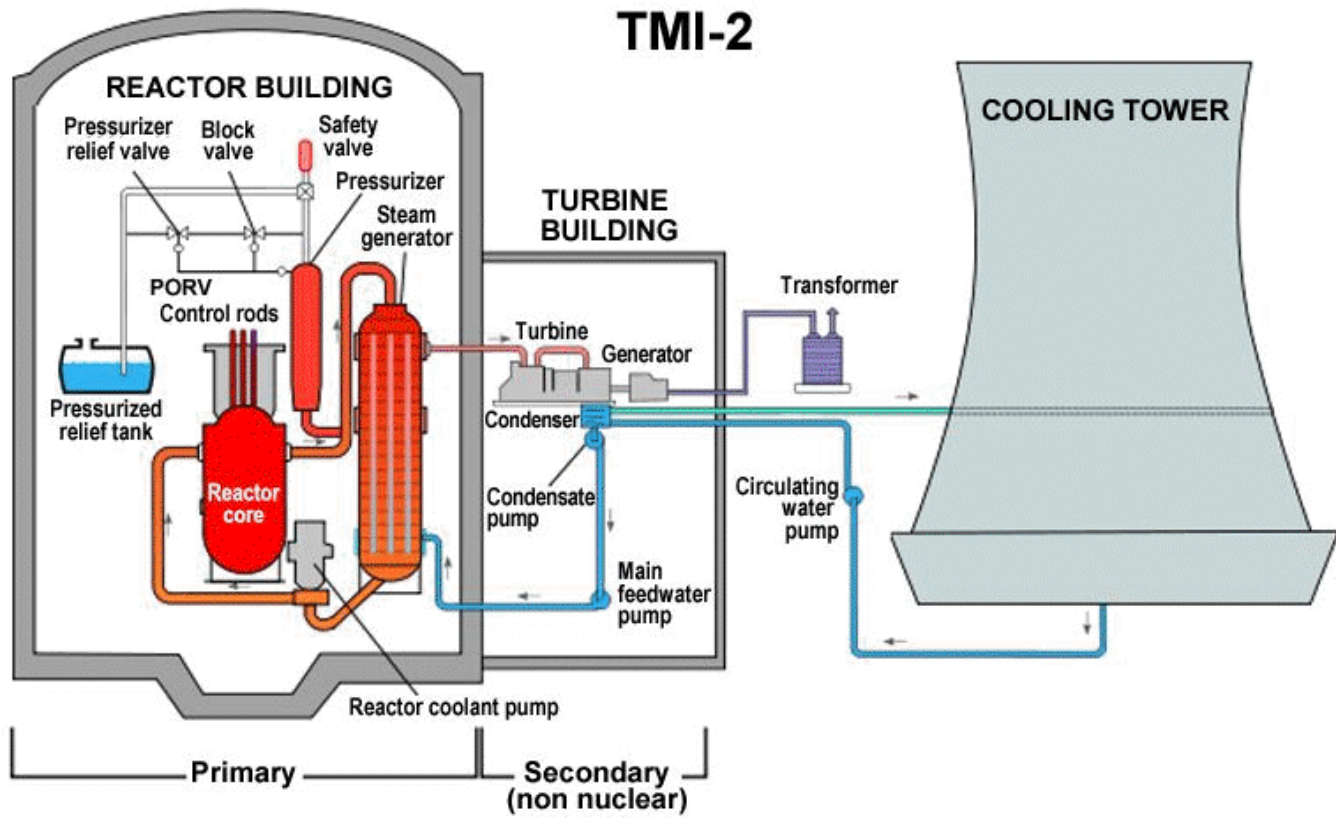

The reactor vessel is a large, forged iron cylinder with a stainless steel interior coating that contains the core, including fuel, control rods, and moderating material (i.e., water in the U.S.).

A vessel, attached to a primary system hot leg, that controls the pressure in the RCS of a PWR using submersible heaters and coolant spray.

A component of the reactor coolant system (RCS) that pumps primary water (coolant) through the system. It pushes hot water out of the reactor core, transferring the heat to the steam generators. The reactor coolant pump helps control pressure and temperature in the core.

In a PWR, the heat exchanger used to transfer the heat energy from the primary reactor coolant to the secondary feedwater. The feedwater is allowed to boil and provide steam to the main turbine generator.

The building that contains the primary systems of the power plant (e.g., the reactor vessel, steam generator, pressurizer, and coolant pumps).

## Review of Typical PWR Reactor System

Take a moment to review basics of the primary system in a typical PWR. Remember that the primary system includes everything related to the reactor system.

Select the reactor, pressurizer, coolant pump, steam generator, and containment wall for an explanation of each component's role.

Let me [compare a PWR and a BWR](#).  
[PWRBWR](#)

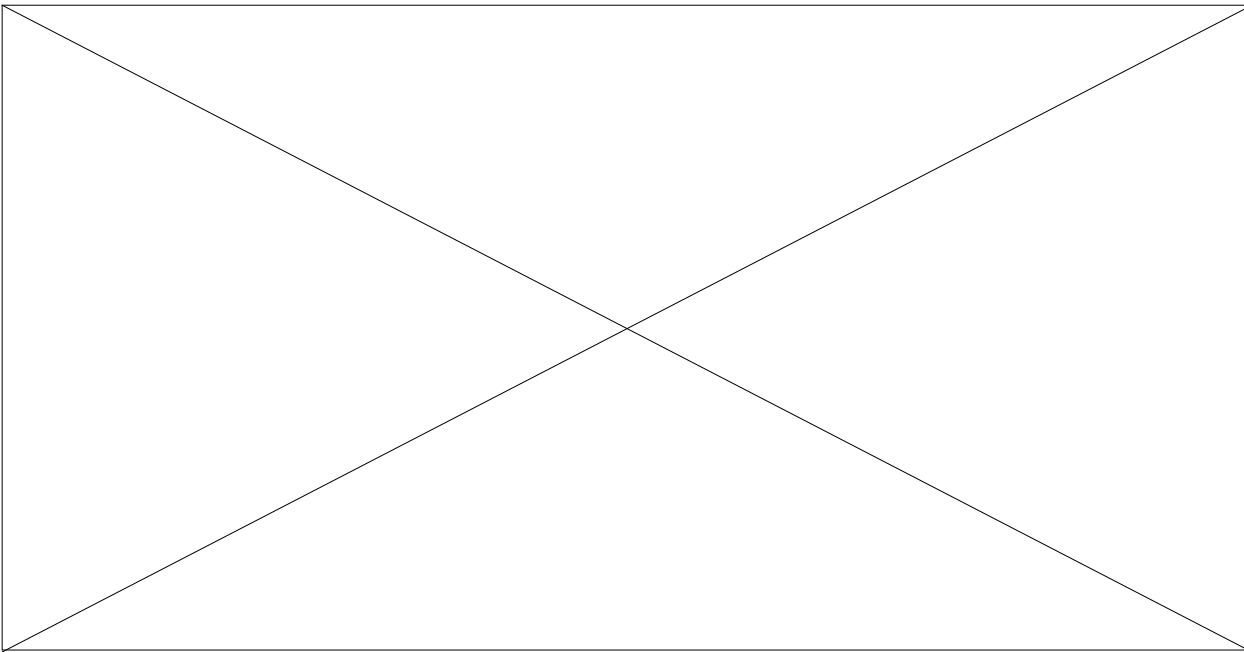

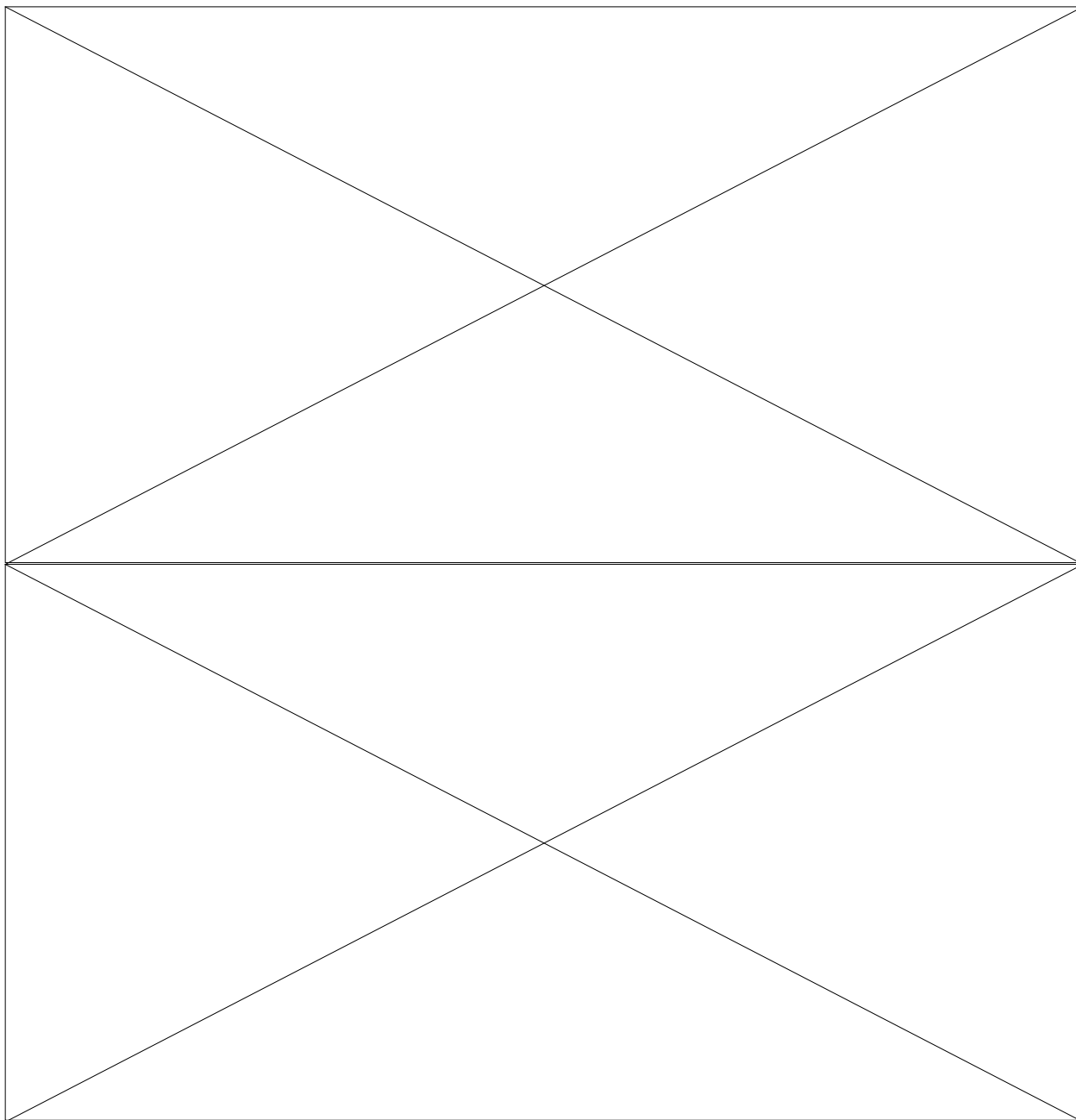

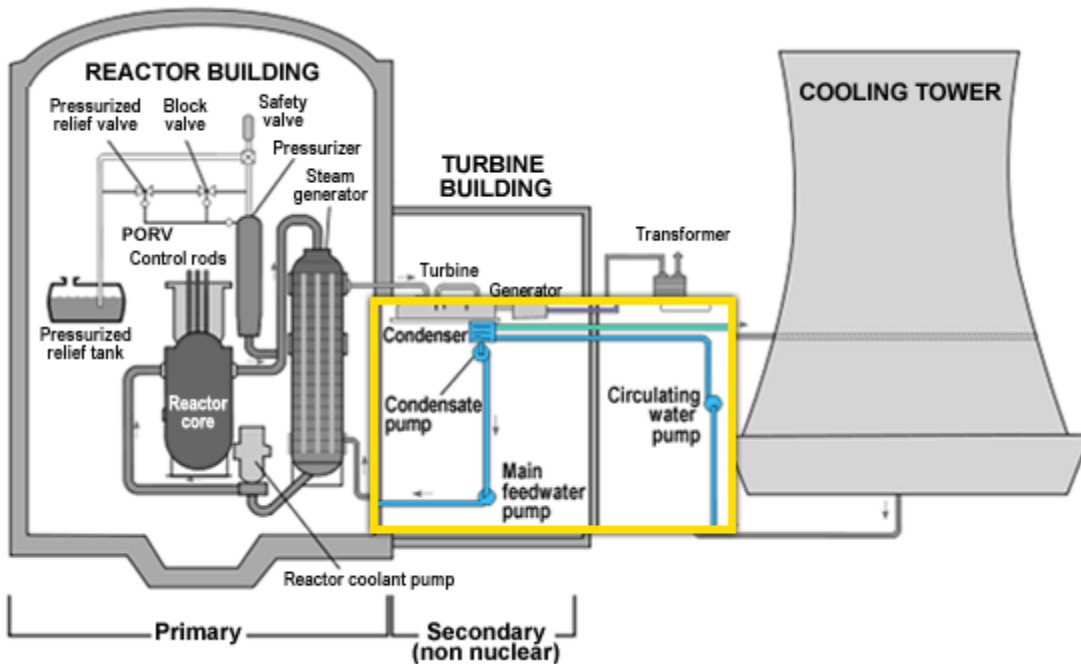

## Loss of Feedwater and Failure of the Auxiliary Feedwater System

The incident began in the secondary (steam) section of the plant when the feedwater pumps malfunctioned. A problem with the condensate polishing (clean-up) system caused a loss of suction to the feedwater pumps. This caused them to trip, interrupting feed flow to the steam generator. As the water level lowered in the steam generator, the reactor automatically tripped (scrammed) and shut down per its design.

Although the reactor successfully shut down, the core's decay heat caused the reactor coolant temperature and pressure to rise. After a trip, this decay heat would be removed from the reactor coolant system by the auxiliary feedwater system providing feed to the steam generators. However, the auxiliary feedwater system was improperly aligned and could not immediately feed the steam generators.

The reactor coolant temperature and pressure continued to rise due to the decay heat not being adequately removed.

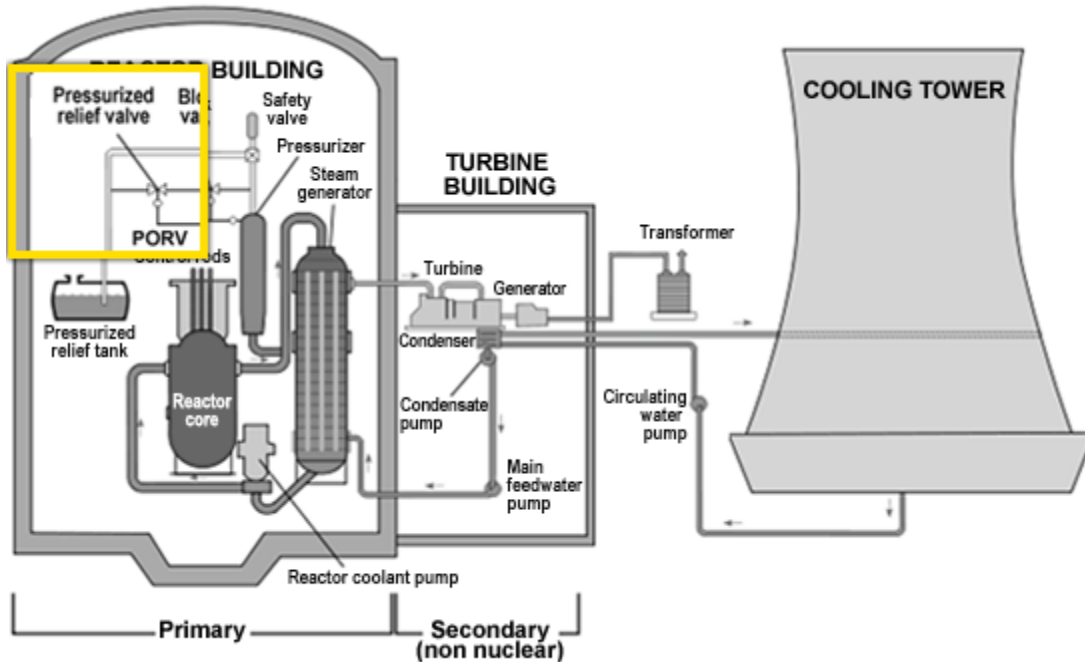

## The Power Operated Relief Valve Opens

In response to the rising primary pressure, the power operated relief valve (PORV) on the pressurizer automatically opened. The PORV is a pressure relief valve that opens and closes automatically to help limit the pressure in the pressurizer below that of the code safety valves. The PORV opened, as intended, to prevent the pressure in the pressurizer and reactor coolant system from reaching a dangerously high level.

## The PORV Malfunctions

The PORV malfunctioned and stayed stuck in a partially open position. If the PORV had functioned properly, the incident would have been an uncomplicated trip and the plant most likely would have been recovered in an uneventful manner.

However, the stuck-open PORV caused Reactor Coolant System (RCS) pressure to lower while the water level in the pressurizer continued to rise, leading to a gradual loss of reactor coolant pressure in the core. This allowed coolant in the core to start to boil, and the steam 'bubble' shifted from the top of the pressurizer to the reactor vessel head.

At this point, since the water in the pressurizer was high, the operators assumed that the core water level was satisfactory. They had no abnormal indications on the control panels alerting them that there was a problem in the core; there was no instrumentation that showed the actual level in the core itself while in this condition. Additionally, the position indicator for the PORV showed the **demand** state (CLOSED) rather than the actual state.

After sensing the loss of reactor coolant pressure, safety equipment automatically started. Since the operators believed the core to be covered, they stopped the safety equipment in order to prevent the pressurizer from overflowing with water. Their training made them especially concerned about a full pressurizer and the pressure control problems that would result from the 'solid' condition.

## Removal of More Water Leads to a Loss of Coolant Accident

In response to the high water level in the pressurizer, the operators increased the amount of water being removed from the RCS (letdown) via the purification system in an effort to keep the pressurizer from overflowing. The effect of increased letdown, coupled with the stuck-open primary PORV, led to a loss of coolant accident (LOCA) condition.

Remember, the amount of pressure in the core is related to the control of temperature in the core. To control pressure in the core, the operators manipulate the ratio of water and steam in the pressurizer as well as its temperature.

Move the tab along the slider bar for information about the relationship between temperature and pressure inside the reactor core.

For non-sighted users, please use these skip links to get to the items on the slider.

- [First Image](#)
- [Second Image](#)
- [Third Image](#)

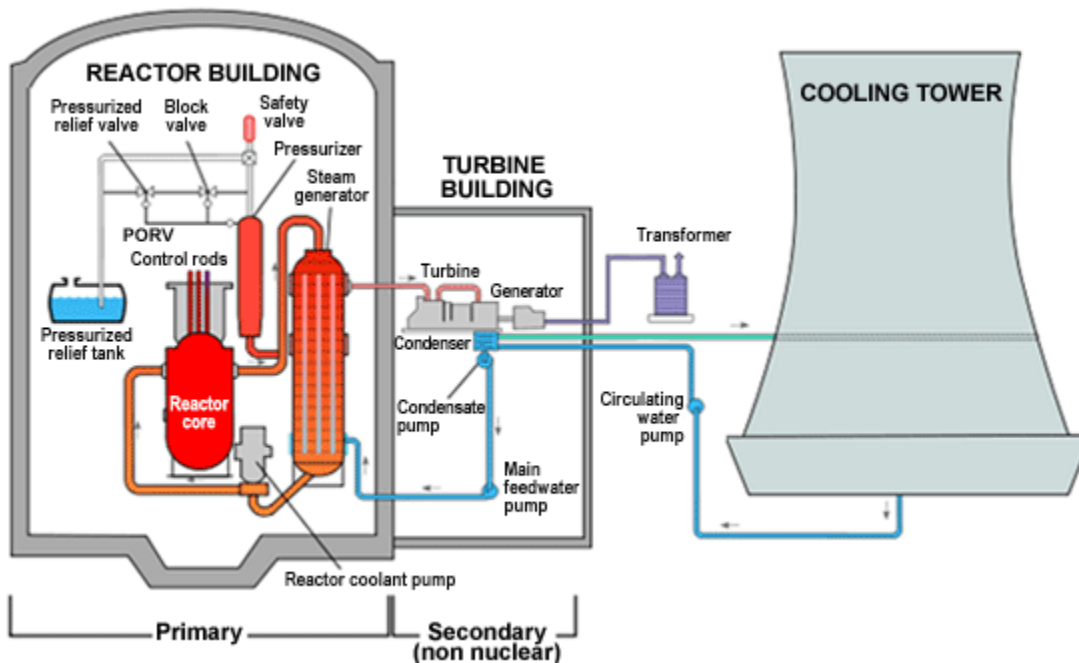

Under normal conditions, consistent temperature and pressure are controlled throughout the primary system.

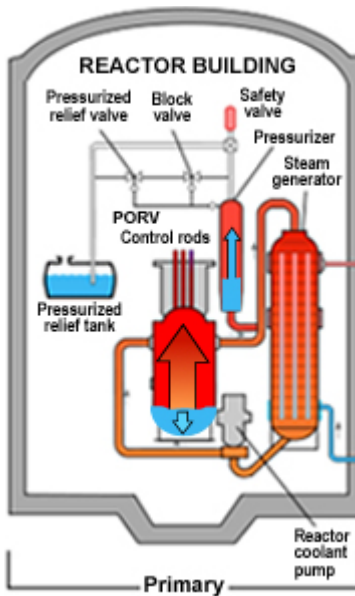

Less steam in the pressurizer due to the PORV malfunction results in more water in the pressurizer.

More water in the pressurizer means less water in the core.

Less water in the core means a higher temperature in the core.

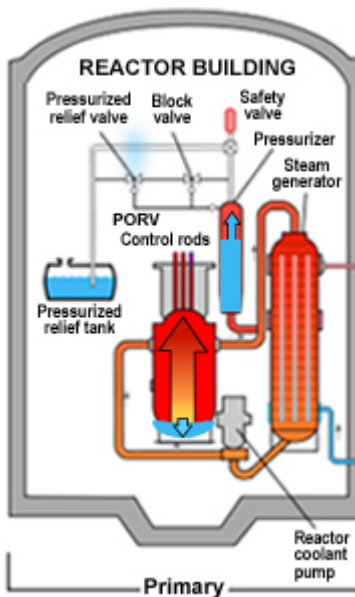

Due to the PORV malfunctioning, steam escapes from the pressurizer so more water flows into it to maintain the pressure. Even more water in the pressurizer results in less water in the core.

The temperature in the core continues to rise as the water decreases in the core.

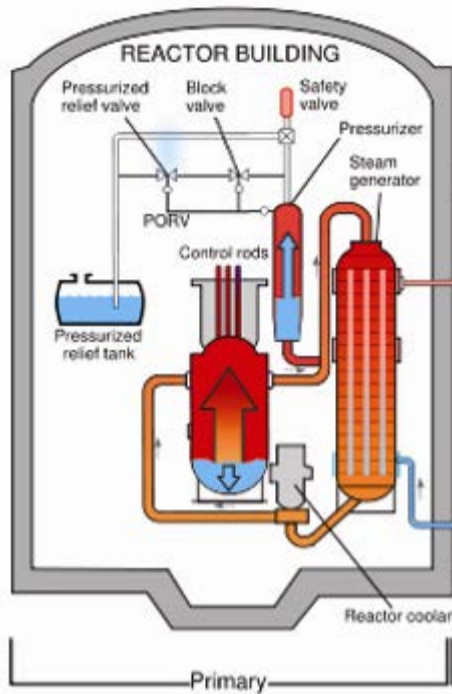

### The Reactor Coolant Boiled in the Core

As the amount of water in the pressurizer increased, and the reactor coolant was diverted to the purification system, the resultant low pressure and high temperature caused the remaining reactor coolant to boil inside the core. In addition, the low coolant pressure caused cavitation and high vibrations in the reactor coolant pumps. The operators were trained to turn off the reactor coolant pumps in this situation, which they did.

Up until the point that the reactor coolant pumps were secured, enough water and steam was flowing through the core to remove its decay heat. Once secured, the amount of reactor coolant flowing through the core was inadequate to remove the decay heat generated in the fuel and the remaining coolant in the core boiled away.

### Overheating Fuel Rods Leads to Core Damage

With little or no cooling available to remove decay heat, the reactor fuel rods started to overheat, crack, and break down. The lack of decay heat removal caused the fuel pellet temperature to rise to the point that the fuel cladding began to melt.

The cladding, which is the first barrier to fission product release, was breached, releasing radioactive fission products into the reactor coolant.

The reactor core experienced a significant amount of fuel melt at this time, reaching almost 50%. A portion of the molten core flowed sideways out to the edges of the core after melting through the stainless steel core support assembly. That material (a mixture of melted fuel, clad, and structural steel known as corium) then flowed down to a lower portion of the reactor vessel, where it cooled and became solid material again. Some of the lower portion of the fuel assemblies—those that had sufficient reactor coolant during the accident—remained intact.



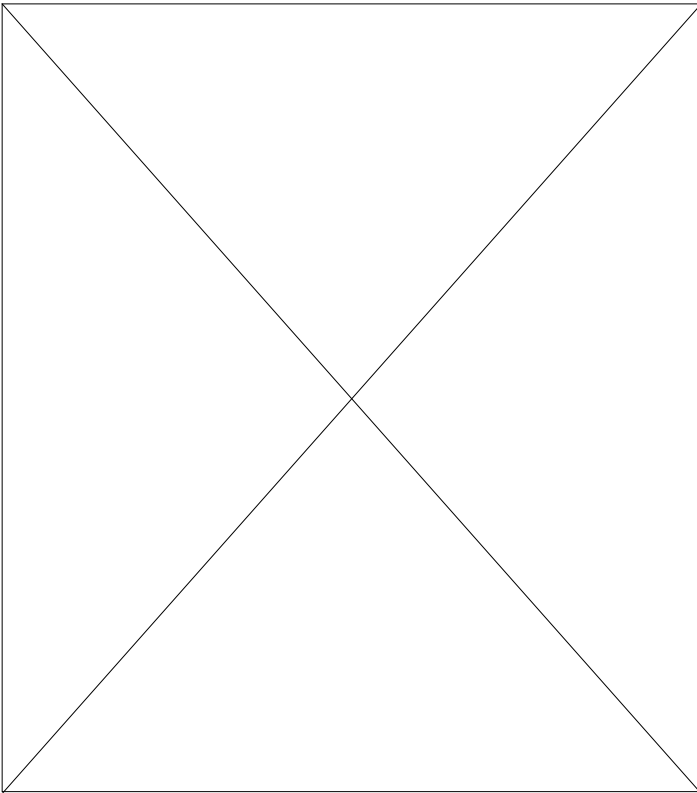

## **Restarting Reactor Coolant Pumps Causes Severe Core Damage**

Later, the operators recognized that the PORV was partially open and isolated it; the reactor coolant pumps were also restarted. Restarting the reactor coolant pumps caused relatively cold water to be pumped onto the now very hot and very brittle fuel rods, causing further severe damage to the core.

Years later, television cameras lowered into the reactor core revealed a large void where the top half of the core had been. Rubble, including fuel pellets and fuel rod debris, was seen on the top of the lower half of the core.

Select Play to view the video of the core damage. (View [transcript](#).)

### **Upper Core Damage:**

Early information on post-accident conditions was obtained by visual inspections performed with miniature underwater television cameras. The first opportunity to view the core region damage was in 1982, when one of these miniature cameras was inserted through a control rod mechanism, down through the plenum, and into the upper core region. The operation was known as “Quick Look.” A pile of fragments was resting on the remains of the core. The top of the rubble bed was five feet below the top of the original core region. Much of the debris was shapeless and unrecognizable. Scattered about in the debris were some recognizable components: springs, pieces of control rod assemblies, tops of fuel elements and rods of various length. The void region was five feet deep and extended in many places all the way out to the edge of the core.

### **Plenum Damage:**

Before further investigations and defueling could begin, the head and the plenum had to be removed from the reactor vessel. The head was removed in July 1984 and placed on a shielded storage stand in the reactor building. The plenum was removed from the reactor vessel in May of 1985. It was transferred to its storage stand in the flooded deep end of the refueling canal. The damaged area on the underside of the plenum was inspected during the transfer operation. This was the first time the whole grid plate and the associated damage

was clearly visible. The foamed appearance of the stainless steel is caused by the interaction of the steel with steam at high temperature.

### **Work Platform:**

To defuel the reactor, workers stand on a six-inch thick, stainless steel, rotatable work platform, mounted on top of the reactor vessel. Through a slot in the platform, they use tools with thirty foot long handles to accomplish defueling operation. In October of 1985, workers began to remove the tops of some of the standing fuel bundles and other debris, to allow installation and operation of the canister positioning system. This is a carousel-type device suspended under the work platform. It holds five defueling canisters.

### **Removing Top:**

The top of the collapsed fuel core looked like this. The fuel rods and large pieces were picked up individually and placed in canisters. This was the pick-and-place defueling phase. As defueling progressed, the rubble and loose debris were removed using a tool called the spade bucket. The spade is the straight part of this tool. It dug into the rubble and the bucket was then closed on the rubble to lift it into the canister. A hard layer discovered earlier by probing with a pointed rod was reached. Defuelers found that their hand-operated tools could not break through the solid mass. In addition, a wall of solid material was discovered around the periphery of the core.

### **Core Bore:**

In July 1986, after most of the loose debris had been removed, the core stratification sampling project, better known as "Core Bore," was begun. A specially modified drilling rig, provided by the Department of Energy, was mounted on top of the reactor vessel, and hollow core drill bits were used to bore into the damaged core. From each of ten locations, a drill string, containing a long cross-sectional sample of the core, was extracted and placed into a defueling canister. This was later sent to the Department of Energy facilities in Idaho for further study. Videotape surveys were then performed in each three and one-half inch diameter hole.

The middle of the core region was found to be a solid mass of once-molten material that extended as deep as five feet at the center of the core. This mass was found to be quite hard and brittle; apparently ceramic in nature. Visible in this mass, particularly near the top, were metallic streaks and clumps. These apparently were partially melted end fittings and other structural components. No significant voids were seen in the ten locations examined.

At the bottom and sides of this mass, agglomerated material, consisting of fuel rods and pellets, surrounded by once-molten material, was observed. This is a transition zone between the once-molten mass and the intact fuel rods and fuel rod stubs. Under all of this are stubs of fuel rods. They are shiny, indicating they were underwater throughout the accident and not exposed to the oxidizing steam environment.

### **Lower Core Damage:**

Videotape inspections of the lower CSA show that in most places, there is no damage and little debris between the plates. On the East side of the reactor, however, a large amount of once-molten material was observed. The material appears to have flowed down from the flow holes in these plates. This material was visible from four different core bore inspection locations, all on the East side of the reactor. The actual route, or routes, whereby the core material may have reached the lower core head was not found at this time. The lower head of the reactor vessel was videotaped via two access paths.

### **Removing Lower:**

In 1985, cameras were lowered through the annular space between the core support assembly and the reactor vessel wall. On the way down, the visible external surfaces of the core support assembly were inspected to see if any structural damage occurred. Not only was there no damage of any kind visible on the core support assembly, there was little or no debris accumulation in this region. In the lower head region, however, piles of rubble-like debris were found. It was estimated that there are ten to twenty tons of rubble in the lower head. Also visible was debris hanging down through some of the flow holes in the flow distributor head. The material appears to have been molten and possibly fractured on cooling. On the North side of the lower head was found a wall of debris, standing fifteen inches high and over five feet wide. The second inspection path put a camera right in the center of the lower head. During the core bore operation, a camera was lowered all the way through the lower CSA and the flow distributor head into the lower head region. The debris in the center of the lower head was granular and was piled up almost to the flow distributor head.

### Summary:

A summary of conditions in late 1986 showed the bed of rubble removed, exposing a mixture of once-molten, re-solidified debris in the lower center of the core. This was five feet thick in the center, and one foot thick at the edges. Below and around this mass were the remains of fuel assemblies still in their original form and locations, varying in height from one foot to over five feet. In addition, a large amount of debris made its way to the lower head region.



### Check Your Knowledge

#### What was the sequence of events during the TMI accident?

Enter numbers (1 for first through 6 for last) in the correct order, then select Done.

- Restarting reactor coolant pumps causes severe core damage
- Overheating fuel rods leads to damage to the core
- The reactor coolant boiled in the core
- Removal of more water leads to a LOCA
- The PORV opens and malfunctions
- Loss of feedwater due to failure of Main/Normal Feedwater System



## Check Your Knowledge

- **What caused or worsened the Three Mile Island accident?**

Select all that apply, then select Done.

1. correct:Equipment failure
  2. correct:Operator error
  3. correct:Poor control panel design
  4. Negligence by plant owners
  5. Lack of qualified operators
- Correct. The incident was precipitated by equipment failure and worsened through operator error and poor control panel design.
  - Incorrect. The incident was precipitated by equipment failure and worsened through operator error and poor control panel design.

## Release of Fission Products

### Release of Fission Products in the Containment Building

Fission products (mostly gases) escaped from the damaged reactor core into the RCS. Due to the stuck open PORV, the pressurizer relief tank (PRT) pressure increased to the bursting point of its installed rupture disk.

The reactor coolant, containing these fission products, now had a direct release path into the containment building atmosphere. The rupture of the PRT severely contaminated the containment with the fission products released from the fuel cladding.

Again, control panel designs prevented the reactor operators from easily seeing that the PRT had ruptured. These indications were located on a control panel that was located behind and out of sight of the main control panel.

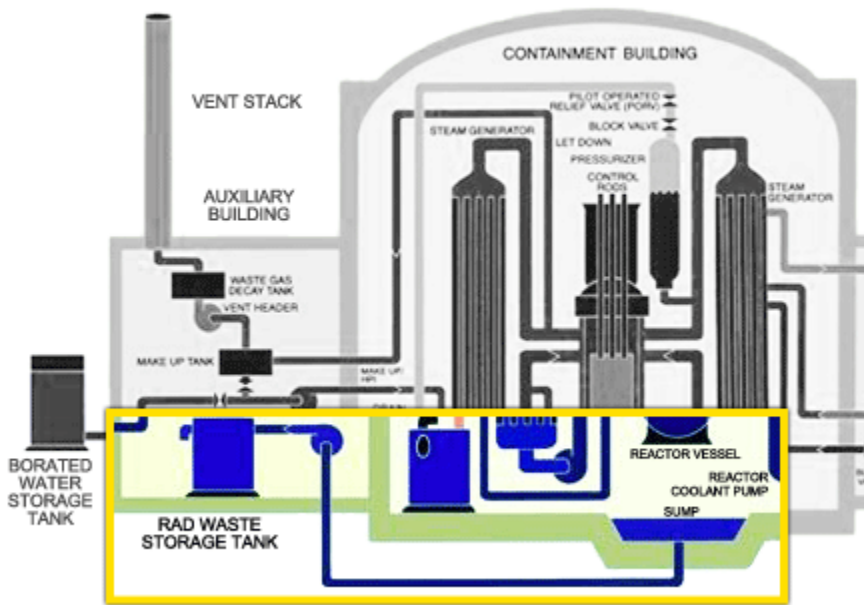

## Transfer of Fission Products to the Auxiliary Building

The coolant escaping into the containment building was being collected in the sump. After reaching a high sump level, the sump pump automatically started and pumped the water to the Auxiliary Building (AB). The fission product gases trapped in the coolant were released into the AB atmosphere and then entered the AB ventilation system.

Due to the high concentration of fission products in the water from the containment sump, as well as the reactor coolant water in the purification system, the AB atmosphere contained a high enough level of radioactive gases that the AB had to be evacuated.

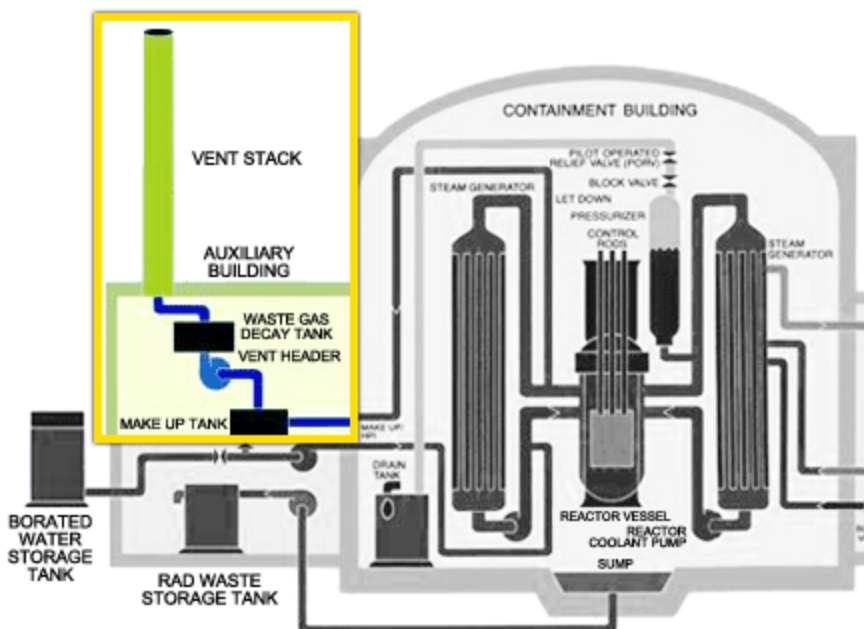

## Escape to the Surrounding Environment

The major release path to the outside environment was via the waste gas system. The fission product gases contained in the letdown coolant were being stripped out in the volume control tank, which is then vented to the waste gas system. A vent in the waste gas system allowed the gases to be blown out the ventilation stack via the AB ventilation system.

Tell me about [the radiological consequences](#) associated with the accident at TMI2.

The radiological consequences for the surrounding area were:

- Maximum projected offsite dose: 100 millirem
- Average dose to population: Approximately 1.4 millirem per person
- Projected additional cancers: 0 to 1



## Check Your Knowledge

### 1. How did the release of core fission products occur?

Select your answer and then select Done.

- The containment building did not function as designed. Contaminated coolant seeped into the concrete and resulted in contamination of the entire structure.
  - Radioactive gases were expelled through the PORV and then vented to the AB, where they entered the primary ventilation system of the AB.
  - Operators could not control the pressure in the pressurizer, resulting in a steam explosion. Radioactive water and gases seeped through cracks to escape.
  - correct:Radioactive gases were vented to the waste gas system, where a leak allowed the gases to enter the auxiliary ventilation system and be blown out the ventilation stack.
2. Correct. The sequence of events that led to the release of fission products was a release of fission products in the containment building, because of the ruptured pressurizer relief tank, followed by transfer of fission products to the AB through the sump and waste gas system, and then the fission products escaped to the surrounding environment through the vent.
  3. Incorrect. The sequence of events that led to the release of fission products was a release of fission products in the containment building, because of the ruptured pressurizer relief tank, followed by transfer of fission products to the AB through the sump and waste gas system, and then the fission products escaped to the surrounding environment through the vent.



## Check Your Knowledge

**Which events occurred inside the reactor system, and which were involved in the release of fission products to the environment?**

Enter the number from the Answer Options in the corresponding field, then select Done.

Answers Options:

1-Inside the Reactor            2-Release of fission products into the environment

- Removal of more water leads to a LOCA
- The PORV opens and malfunctions
- Contamination of the containment building atmosphere
- Transfer of RAM to the AB
- Escape of fission products from the AB
- Loss of feedwater due to failure of the auxiliary feedwater system

## Chapter Summary



### Key Points

- TMI was the worst accident in U.S. nuclear power history. It resulted in significant changes to both the U.S. nuclear power industry and the NRC.
- The accident was caused and exacerbated by a combination of factors, including equipment malfunctions, operator error, and poor instrumentation design.
- The sequence of events inside the reactor system during the accident was:
  - Loss of feedwater due to failure of main (normal) feedwater system, leading to a reactor trip

- The PORV opens (per design), but malfunctions and does not reclose
- Loss of coolant through open PORV and increased letdown results in a LOCA
- LOCA and stopping reactor coolant pumps leads to the core boiling, uncovering, and overheating
- Overheating fuel pellets lead to damage to the core and cladding failure
- Restarting reactor coolant pumps makes core damage worse



## Key Points

- The sequence of events that led to the release of fission products to the environment was:
  - Release of fission products in the containment building because of the ruptured PRT
  - Transfer of fission products to the AB through the containment sump
  - Escape from the AB to the outside environment via the waste gas system



# The Chernobyl Accident

## Chapter Introduction



### Chapter Overview

The April 1986 disaster at the Chernobyl nuclear power plant in the Ukraine was the product of a flawed Soviet reactor design coupled with serious mistakes made by the plant operators and staff. It was a direct consequence of Cold War isolation and the resulting lack of any safety culture.

The following chapter will briefly describe the Soviet Union's RBMK-1000 reactor design and discuss the events leading up to, and immediately following, the Chernobyl-Unit 4 accident.



### Objectives

At the end of this chapter, you will be able to:

- Differentiate between the Chernobyl design and United States (U.S.) light water reactors (LWRs) that reduces the likelihood of a similar accident in the U.S.
- Sequence the basic events that led to the accident at Chernobyl

**Estimated time to complete this chapter:**

35 minutes

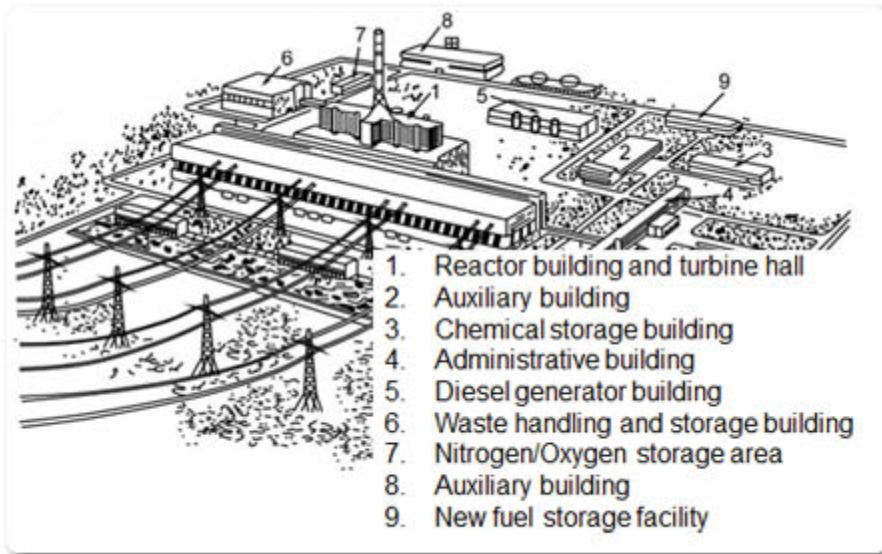
**Soviet Reactor Design****RBMK-1000 Schematic**

The graphic displays the schematic of a typical layout for an RBMK-1000 site. The major structures are:

- Reactor building and turbine hall
- Auxiliary buildings
- Chemical storage building
- Administrative building
- Diesel generator building
- Waste handling and storage building
- Nitrogen/Oxygen storage area
- New fuel storage facility

 Click to enlarge.

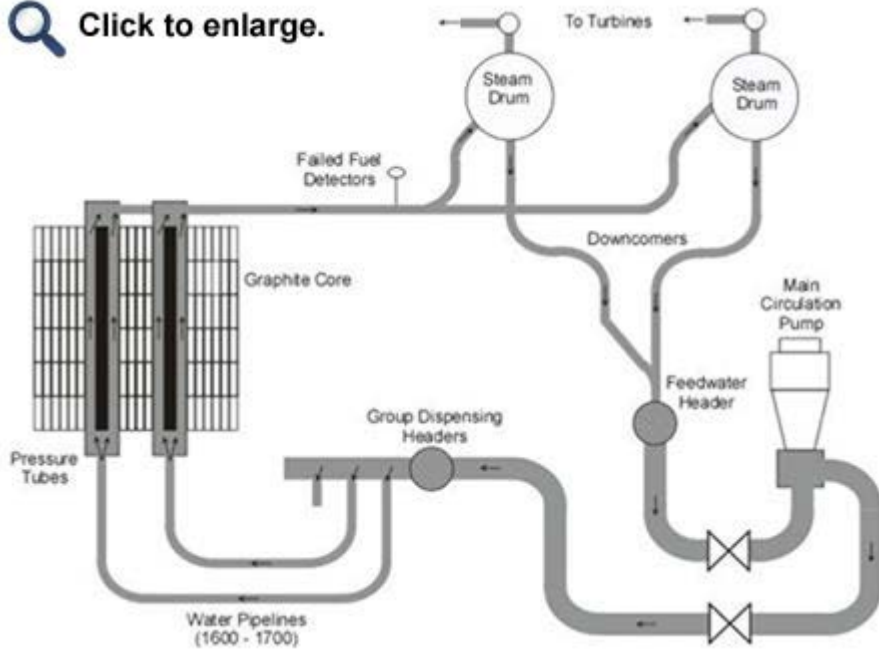

## RBMK-1000 Reactor

The RBMK-1000 is a boiling water, pressure tube, graphite-moderated reactor. The cooling medium is water, which is converted into a steam/water mixture as it passes by the fuel rods. The coolant flows inside 1661 sealed pressure tubes. The steam/water mixture is physically separated in the steam drums. The separated steam is routed to the turbine generators and the separated water is combined with the feedwater from the main condenser and pumped back to the reactor via recirculation pumps. The coolant flows inside the pressure tubes from the bottom to the top. The pressure tubes are surrounded by large blocks of graphite. The graphite serves to slow the neutrons down to the energy required to cause fission (acts as the moderator).

The RBMK-1000 reactor does not have to be shut down to be refueled. Each pressure tube can be individually isolated, opened, and refueled by remotely controlled equipment while the remainder of the pressure tubes continue to operate at power.

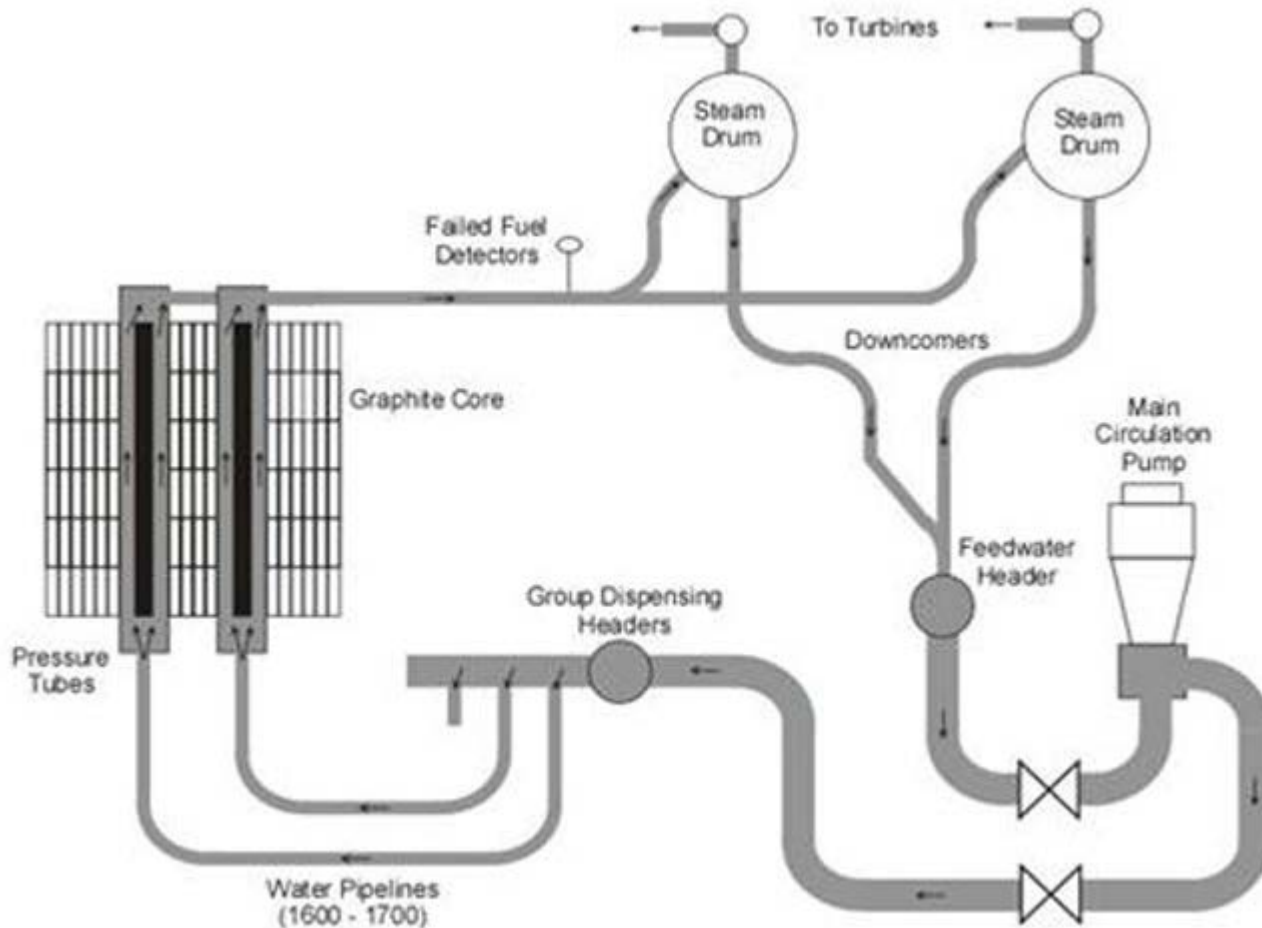

## Check Your Knowledge

- **Which items describe the RBMK-1000 Soviet reactor?**  
Select all that apply, then select Done.
  1. correct:A boiling water, pressure tube, graphite-moderated reactor.
  2. The cooling medium used is air.
  3. correct:Separated steam from the reactor is routed to the turbine generators.
  4. Coolant inside the reactor flows from the top to the bottom.
- Correct. The RBMK-1000 is a boiling water, pressure tube, graphite-moderated reactor. The cooling medium inside the reactor is water. During reactor operation, separated steam flows to the turbine generators and the coolant flows from the bottom to the top.
- Incorrect. The RBMK-1000 is a boiling water, pressure tube, graphite-moderated reactor. The cooling medium inside the reactor is water. During reactor operation, separated steam flows to the turbine generators and the coolant flows from the bottom to the top.

## Events of Accident



### Special Test

At Chernobyl Unit 4, a special test (written by non-nuclear trained electrical engineers) was to be performed to help evaluate a new voltage regulating system. This system would allow plant emergency equipment to be powered by the plant's turbine-driven electrical generator as it slowed following a turbine shutdown. Since the test's authors did not consider the test to be of safety significance, the test procedure was not submitted for the usual safety reviews. The same test had been rejected by the staff of another plant as too risky.

The test called for a reduction in power to 50% (1600 MW), blocking (overriding) the automatic start signal for the plant's emergency core cooling system (ECCS) and connecting four of the reactor's eight recirculation pumps to the turbine generator under test. Normally, the reactor would trip following a turbine trip signal. To prevent this and allow the performance of a second test if needed, the operators took several compensatory measures that overrode/blocked normal safety functions.

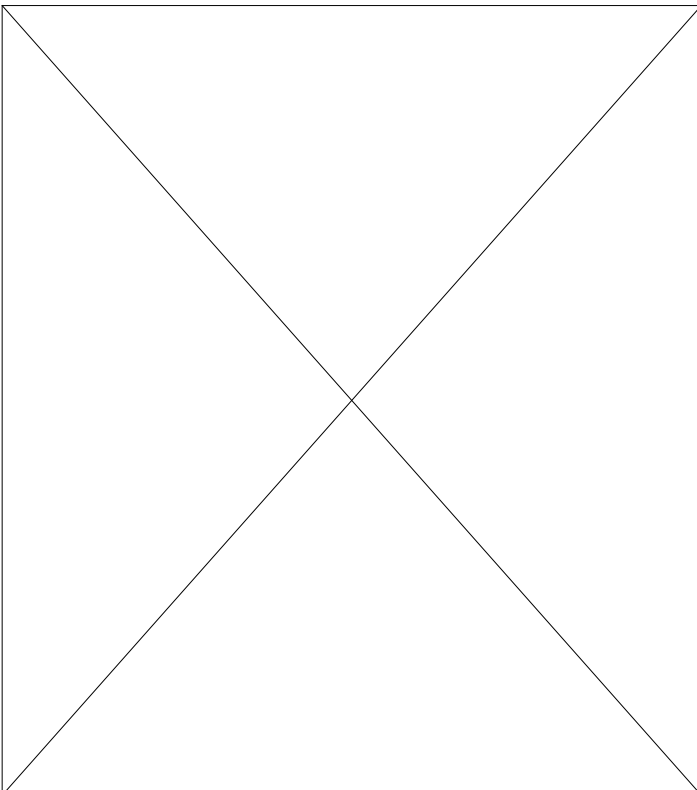

### Faulty Test Design

Due to a faulty test design (coupled with operator error), the planned power level of 50% was not maintained and power was allowed to drop too low. In an attempt to continue the test, operators tried to raise power to the proper level but a cascading effect ensued within the reactor causing an uncontrollable core power rise and catastrophic steam explosion.

In the aftermath, television crews documented the RBMK-1000 reactor design, the failed Soviet reactor test, and the operator errors that occurred. The end result of the Chernobyl test led to the worst nuclear event seen in modern times.

Select Play to view the video of the Chernobyl accident. (View [transcript.](#))

## Plant Design

These reactors are of the type unique to the Soviet Union. They are graphite moderated and are cooled by boiling water. The top of the vault is a 1000 ton head. This supports the control rods, the top of the pressure tube and the outlet steam pipes. The steam flows to a steam separator. The steam goes to the turbine, the water to the main coolant pumps, then to the inlet headers and then into the core where it boils to produce steam. The core is located in the vault, designed to contain about 12 pounds per square inch. The pressure that would result from the failure of one fueled pressure tube. There were 1661 such tubes. The area over the head is an industrial type, high bay building. People can work on the head while the reactor is operating. The reactor is refueled during operation.

## Test Events

The following is from a Soviet television report on the Chernobyl 4 accident: 25th of April: The reactor is working at nominal power, 3200 megawatts. One o'clock in the morning. The staff have begun to take out the unit for maintenance. Power down to 2600 megawatts. Turbine Generator #7 has been switched off.

In accordance with the test program, the maximum design accident system has been switched off. This is one of the main mistakes made. The taking of this unit out of operation has been held up. In violation of the regulations, the unit continues to operate without proper protection. Power is down to 1600 megawatts, at which the test will take place. The local automatic control system has been switched off. But because of a lack of technical qualification of the staff working there, the power of the reactor could not be stabilized at the planned level. The power has dropped down to 30 megawatts. The reactor is in a very difficult to control situation. The unit is working in a fluctuating way. You have poisoning of the core. You should shut down the reactor. One should only be able to work on the reactor again in 24 hours. But this means that the testing would have to be broken off, so the staff take the decision to in fact continue. The emergency system for the steam system means that you can't work under stable conditions and the staff once again violated the regulations to switch off that system. Power is not sufficient for the testing.

26th of April at 1 o'clock in the morning. By raising the control rods, the staff tried to increase the power of the reactor. The power is stabilized at a level of 200 megawatts, at the cost of raising practically all the control rods out of the core, although the regulations require that the reactor be shutdown under such a situation. This is the worst mistake the staff made. They lost control of the reactor. In addition to the six circulating pumps which would be working, two more in-reserve pumps have switched on. This is a mistake by the staff. This means that you'll get a random increase in power.

In order to make it possible to have a second test, the staff decide to block one more emergency system. This is the steam into the turbine generator signal which is switched off. One o'clock...40 seconds: #8 steam generator is in fact switched on. After a certain period of time, a very random increase in power began to start.

One twenty-three ... 40 seconds: at a order of the shift supervisor all the controls were dropped into the core. However, the reactor had been brought to such a situation by the staff that the scram system couldn't prevent the accident. The designers had never designed for such a sequence of violations of regulations. According to witnesses outside Unit 4, at one twenty-three 40 seconds there were two explosions in sequence. Hot sparks and pieces flew out of the building. The chain reaction ceased after the explosion, but very high temperature fragments led to thirty centers of fire in the core. Then there was a tremendous fire, the fire brigade came and by 5 o'clock in the morning the fire was put out.

### **Accident Examined**

The following comments on the Soviet report on the accident are from a Japanese national television report. A Russian report said that the accident was caused by violations of operational procedures. But let's examine that and see if it really was due to an operator's error. The first violation: April 25th 1400 hours: The bypassing of the emergency core cooling system. Before the experiment, if the ECCS is not bypassed, the reactor will shutdown and the experiment cannot be run. In order to continue the experiment, they have to shut off the device. Therefore, we cannot say this is an operator's error.

The second violation: April 26th 0 hours and 28 minutes AM: automatic control conversion. Since the operator did not switch on the device which keeps the power at a constant level, the power dropped and the reactor became unstable. This was obviously an operation error.

The third violation: the control rods were pulled out too far. They wanted to experiment at a low power output, but they had brought the power too far down. In keeping with the character of this reactor, in order to maintain the power, they had no other way but to pull out the control rods. Whatever person ordered the continuation of this experiment is responsible. Therefore, it is not the operator's error.

The fourth violation: One hour 3 to 7 minutes: the addition of main circulation pumps. The fourth violation was caused by the addition of two pumps which supplied coolant to the core. This caused an excess flow of coolant, which in turn caused the core to become unstable. It was planned in the experiment, therefore it is not an operation error.

Fifth violation: one hour nineteen minutes 58 seconds: the bypassing of the automatic shutdown for the steam separator. This was ordered for the continuation of the experiment. Therefore it is not the operator's error.

The sixth violation: one hour twenty-three minutes 4 seconds: the bypassing of the automatic shutdown system of the reactor. As the turbine slows down, a signal is given to automatically shutdown the reactor. This was bypassed, in order to be able to repeat the experiment. It was not in the experimental procedures. It is the responsibility of the person who forcefully tried to continue the experiment.

If we examine these six violations, there are only two operator errors. A bigger problem is the characteristic of the reactor becoming unstable at low power. Despite this characteristic, they forcefully continued this experiment.

## Reactor Explosion

(no transcript available)

## Explosion Aftermath

As the DOE report states, the entire accident occurred in a period of only about forty seconds. At the beginning, any perturbation in the system which increased void formation, even slightly, could have led to a major power excursion. At any time, during the slow power build-up, up until the power began to rise rapidly, system changes which reduced void formation could have prevented the accident. Once the power began to rise rapidly, there was nothing that could have been done to stop it.

This scene was taken from a helicopter approaching Chernobyl, the morning of April 28th, 1986. Even though it is almost impossible to burn graphite, the Soviets reported that they estimated about 10% of the core graphite burned. This was due to the high temperature resulting from the accident, and was not a cause of the accident. The initial power excursion over-pressurized the vault and blew off the 1000 ton head. This caused a second and much larger excursion and energy release two or three seconds later.

The resulting energy released by the fuel failure, the fuel-coolant interaction, and the release of the stored energy of the reactor completed the destruction of Chernobyl Unit 4.

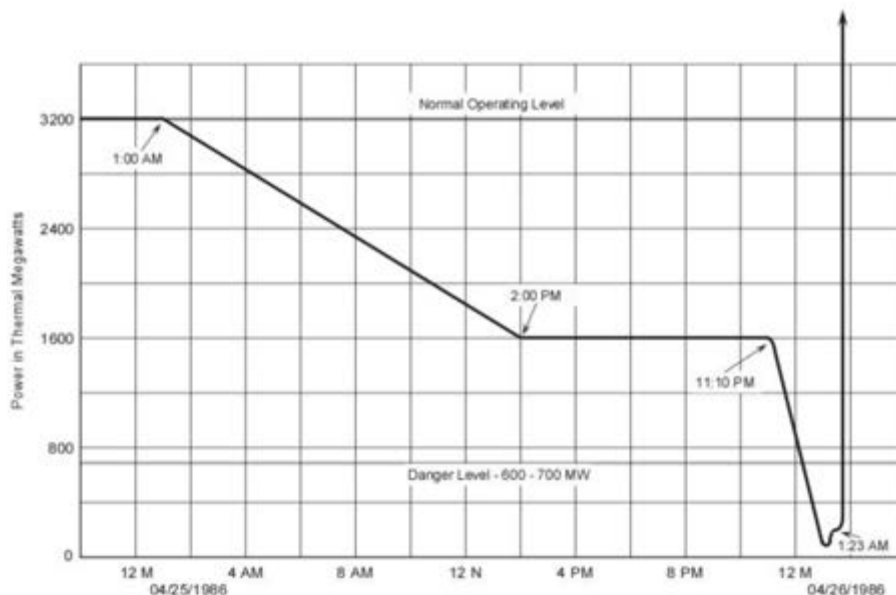

## Operator Errors



Due to operator error, the planned power level of 50% was not maintained and power was inadvertently allowed to drop to about 1% (30 Mw). The operators tried to raise power to the proper level by removing nearly all of the control rods from the core, but could only increase power to about 6%.

In an RBMK reactor, extended operation below 20% is not permitted due to reactor instability (steam bubbles in the coolant increase reactor power and an increase in the reactor power creates more steam bubbles, which causes the power to increase even further: a positive void reactivity coefficient). The operators decided to continue the test despite conditions that called for an immediate reactor shutdown.

This is the opposite of U.S. light water reactors where a negative void coefficient of reactivity is maintained. In U.S. reactors, if power and/or temperature go up, the moderator (coolant) expands and becomes less dense. This leads to a loss of moderation (thermalization) of neutrons, which causes power to go down. Hence, U.S. light water reactors are more inherently stable.

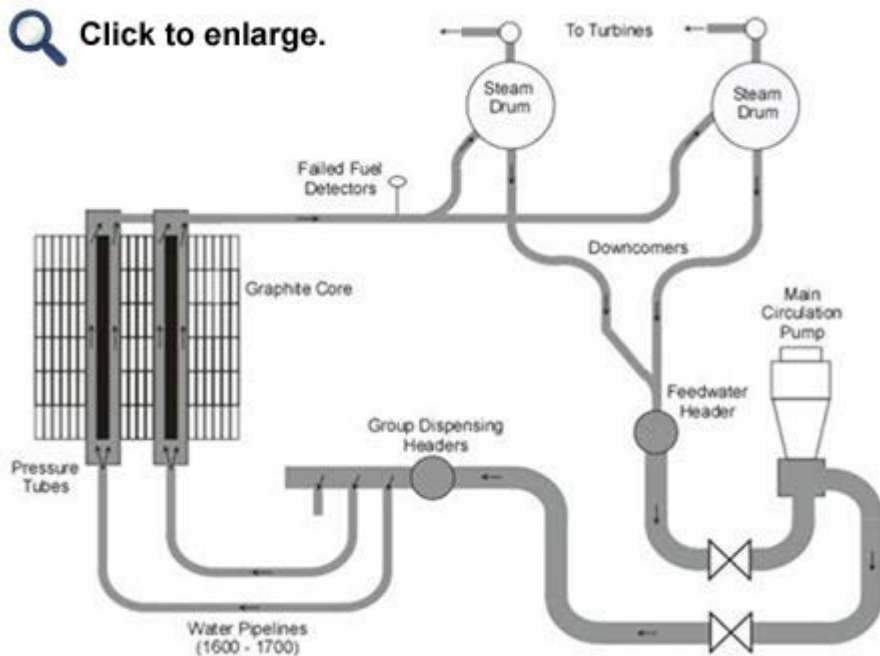

## Test Procedures

In accordance with the test procedure the operators turned on all reactor recirculation pumps. Due to the very low power level at which the plant was operating, the water entering the reactor was mostly from the steam separators and, therefore, was very nearly at its boiling point even before reaching the fuel assemblies. Upon reaching the fuel area it boiled immediately, creating voids that increased power levels.

Continuing the test, the operators then tripped the turbine generator and subsequently the principal method of heat removal was isolated. The temperature increased in the fuel channels causing a significant increase in the steam bubble (void) formation. The increased boiling caused reactor power to rise rapidly. Operators tried to manually trip the reactor, but power was increasing far too rapidly. The fuel temperatures increased so much, and so quickly, that the internal fuel rod pressure burst the fuel cladding, releasing extremely hot fuel fragments into the coolant channels.

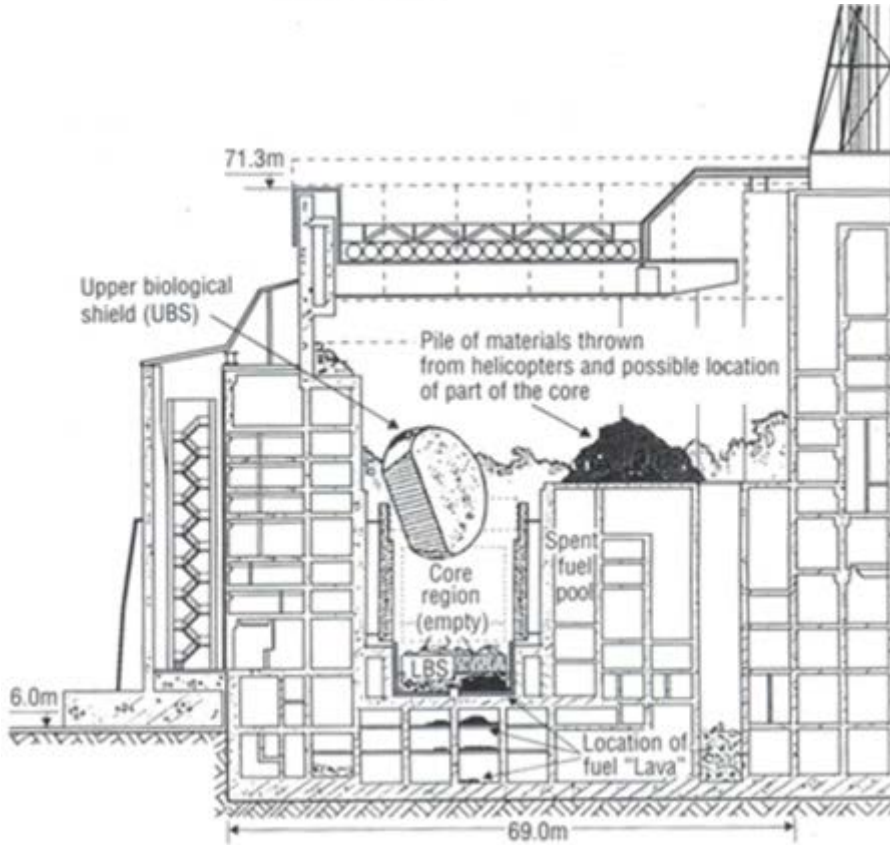
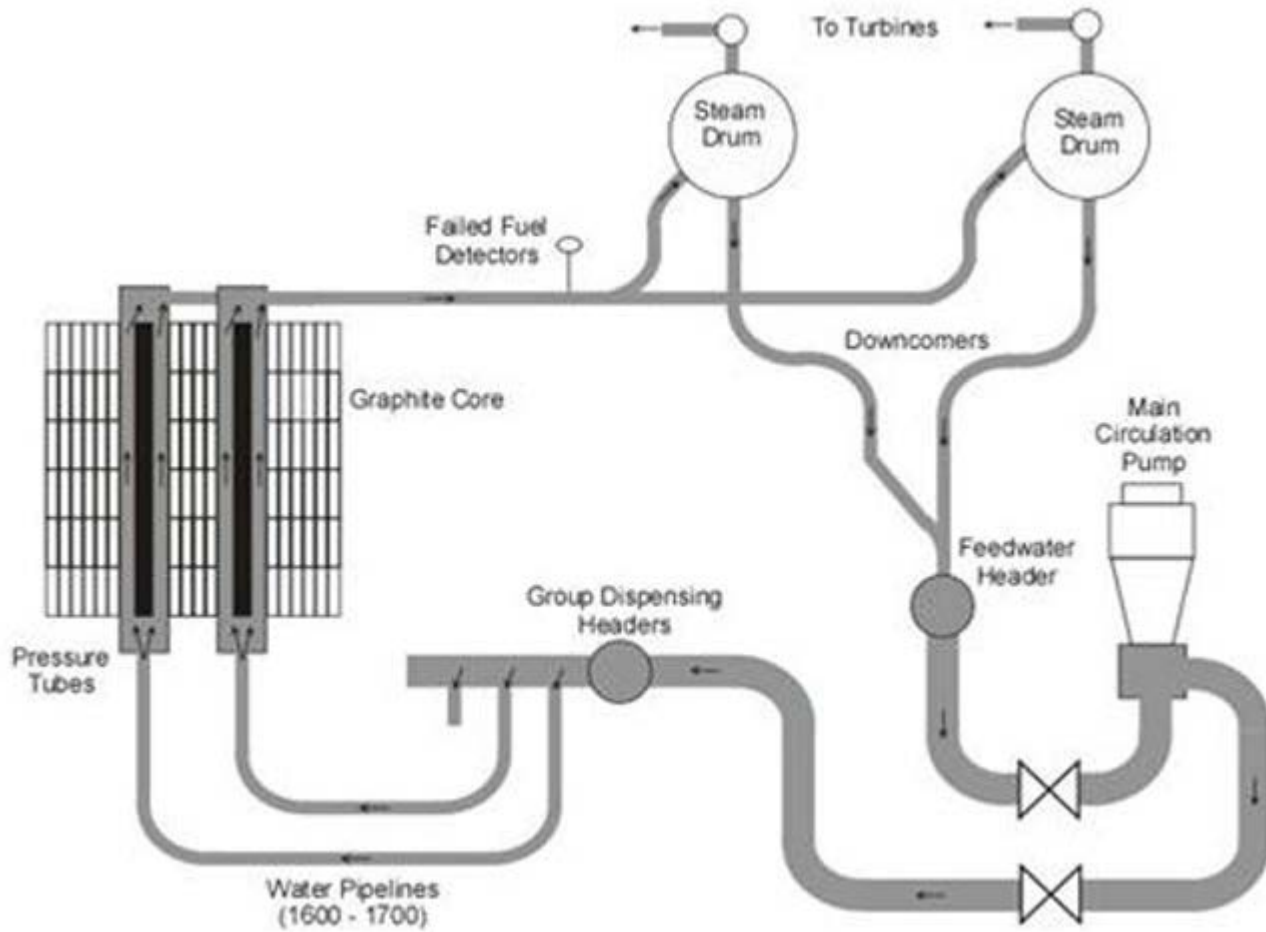

## Reactor Overpower & Steam Explosion

Extremely high pressures resulted from the mixing of the water with the intensely hot uranium fuel. Most, if not all, of the coolant pressure tubes ruptured immediately. The subsequent steam release (steam explosion) was more than sufficient to destroy the area above and around the Unit 4 reactor, and to spread hot pieces of uranium fuel and graphite moderator onto the adjacent buildings. Remember that the RBMK design assumed that the turbine building only needed to be able to contain the rupture of 1 of the 1661 fuel tubes.

A second explosion, occurring about 3 seconds later and much more powerful than the first, caused further damage. About thirty fires were ignited by the materials ejected during the two steam explosions.



## Aftermath

Chernobyl unit 4 is now enclosed in a large concrete shelter, which was quickly erected to allow continuing operation of the other reactors at the plant. However, the structure is neither strong nor durable. The International Shelter Implementation Plan in the 1990s involved raising money for remedial work, including removal of the fuel-containing materials. Some major work on the shelter was carried out in 1998 and 1999. Approximately 200 tons of highly radioactive material remains deep within it and this poses a significant environmental hazard until it is better contained.

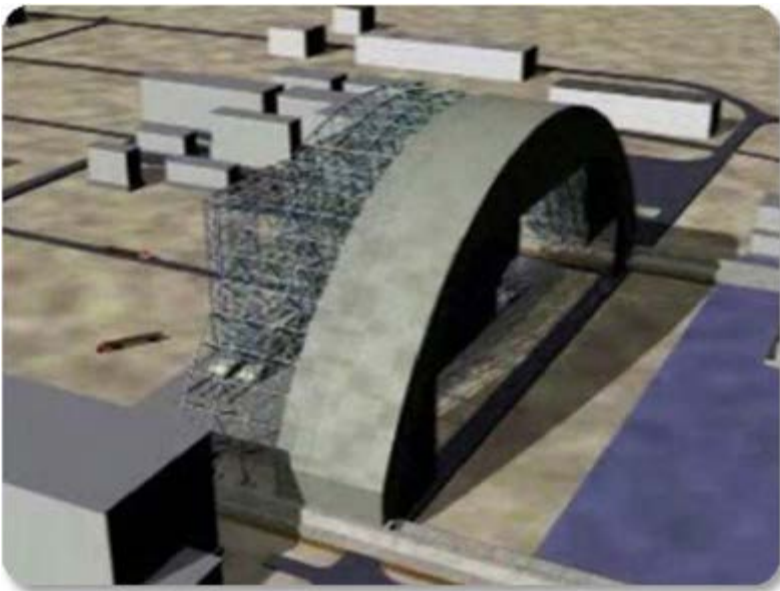

## Future Plans

A New Safe Confinement structure will be built by the end of 2011, which will then be moved into place on rails. It will be an 18,000-ton metal arch, 350 feet high, 650 feet long, and spanning 900 feet to cover both Unit 4 and the hastily built 1986 structure.

Modifications have been made to overcome deficiencies in all the RBMK reactors still in operation. In these reactors, originally, the nuclear chain reaction and power output could increase if cooling water was lost or turned to steam—in contrast to most Western designs. It was this effect that led to the uncontrolled power surge that resulted in the destruction of Chernobyl Unit 4.

The other three reactors at Chernobyl are all, presently, shut down. However, fuel still remains on site and workers are still present to ensure safety of the existing cores. It is estimated that the Ukraine will have the area completely cleared and decontaminated sometime in 2065.



## Check Your Knowledge

**In what order did the following operator-controlled events take place?**

Enter numbers (1 for first through 3 for last) in the correct order, then select Done.

- Operators attempted to trip the reactor manually.
- Operators turned on all the reactor recirculation pumps.
- Operators tripped the turbine generators.

## Chapter Summary

# Plant Decommissioning

## Chapter Introduction



## Chapter Introduction

Decommissioning is defined as the safe removal of a facility from service and reduction of residual radioactivity (radioactivity in structures, materials, soils, groundwater, and other media at a site resulting from activities under the licensee's control) to a level that permits termination of the NRC license. The regulations require the completion of decommissioning within 60 years of the permanent cessation of operations.

This chapter will provide a brief discussion of the decommissioning activities associated with a power reactor facility.



## Objectives

At the end of this chapter, you will be able to:

- Identify the activities and their associated time requirements involved in decommissioning a site.
- Differentiate among the three methods of decommissioning.

**Estimated time to complete this chapter:**

35 minutes

**Decommissioning Activities****Permanent Cessation of Operations**

Once the licensee has made the decision to permanently cease operations, the NRC must be informed in writing within 30 days. This notification must contain the date on which the power generation operations have ceased or will cease. The licensee must remove the fuel from the reactor and submit a written certification to the NRC confirming its action. There is no time limit specified before the fuel must be removed or the certification must be received by the NRC. Once this certification has been submitted, the licensee is no longer permitted to operate the reactor or to put fuel back into the reactor vessel.



## PSDAR

The licensee must submit a post-shutdown decommissioning activities report (PSDAR) to the NRC and the affected state(s) no later than 2 years after the date of permanent cessation of operations.

The PSDAR must:

- Describe the planned decommissioning activities
- Contain a schedule for the accomplishment of significant milestones
- Provide an estimate of the expected cost
- Provide documentation that environmental impacts associated with site-specific decommissioning activities have been considered in previously approved environmental impact statements.



## Decommissioning Activities

After receiving a PSDAR, the NRC publishes a notice of receipt, makes the PSDAR available for public review and comment, and holds a public meeting in the vicinity of the plant to discuss the licensee's plans. Following completion of the required submittals—and allowing for a 90-day waiting period after submittal of the PSDAR—the licensee may commence major decommissioning activities.

These can include the following:

- Permanent removal of major radioactive components (reactor vessel, steam generators, or other components that are comparably radioactive)
- Permanent changes to the containment structure
- Dismantling components resulting in “greater than Class C” waste

Within 2 years following the date of permanent cessation of operations, the licensee must submit a site-specific cost estimate for the decommissioning project. The licensee is prohibited from using more than 23% of the money that was accumulated during operations for the decommissioning process until the site-specific cost estimate is submitted to the NRC.

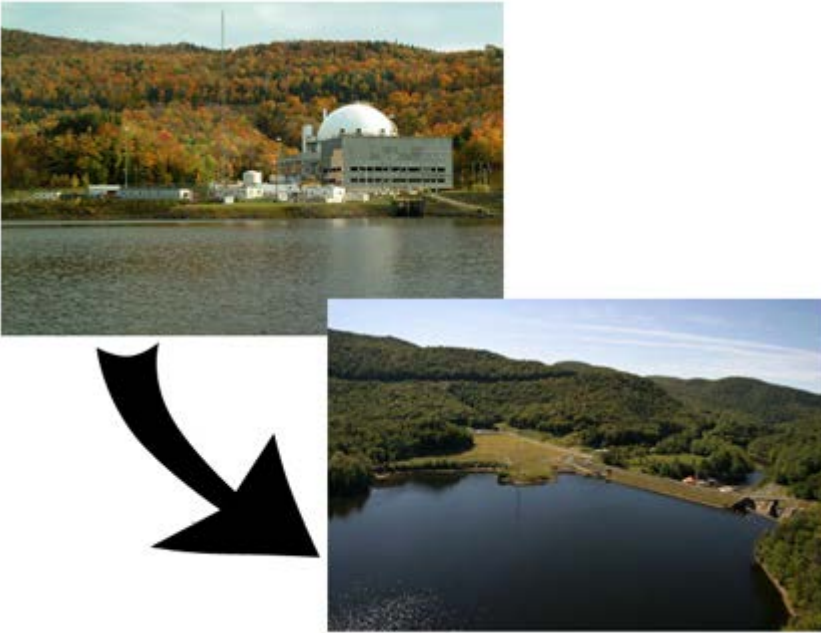

## Conclusion of Decommissioning Activities

In order to conclude the decommissioning process, the licensee must submit a License Termination Plan to the NRC. This must be submitted at least 2 years before the termination date. It must include the following:

- A site characterization (includes a description of the radiological contamination on the site before any cleanup activities associated with decommissioning took place; a historical description of site operations, spills, and accidents; and a map of remaining contamination levels and contamination locations)
- Identification of remaining dismantlement activities
- Plans for site remediation
- Detailed plans for the final survey of residual contamination on the site
- A description of the end use of the site
- An updated site-specific estimate of remaining decommissioning costs
- A supplement to the environmental report

A licensee may choose to operate an Independent Spent Fuel Storage Installation under either a Part 50 or Part 72 license, and release the remainder of the site under a license termination plan.





## Termination Plan

After receiving the license termination plan, the NRC will place a notice of receipt in the Federal Register and will make the plan available to the public for comment. The NRC will schedule a public meeting near the facility to discuss the plan's contents with the public. The NRC will also offer an opportunity for a public hearing on the license amendment associated with the licensee termination plan. If the license termination plan demonstrates that the remainder of decommissioning activities will be performed in accordance with the NRC's regulations, the plan is not detrimental to the health and safety of the public, and it does not have a significant effect on the quality of the environment the Commission will approve the plan by a license amendment (subject to whatever conditions and limitations the NRC deems appropriate and necessary). Once the license amendment is granted, the licensee is authorized to implement the license termination plan.

At the end of the license termination plan process, if the NRC determines that the remaining dismantlement has been performed in accordance with the approved license termination plan, and if the final radiation survey and associated documentation demonstrate that the facility and site are suitable for release, then the Commission will terminate the license or release non-ISFSI portions. At this point the decommissioning process is considered complete.



## Check Your Knowledge

- **Which items describe the events that occur when a licensee decides to permanently cease operations of a nuclear plant?**

Select all that apply, then select Done.

1. correct: The NRC must be informed within 30 days.
2. The NRC must be informed immediately.

3. correct: This notification must contain the date when operations will cease.
  4. There is no time limit on when generator operations will cease.
- Correct. Once the licensee has made the decision to permanently cease operations, the NRC must be informed in writing within 30 days. This notification must contain the date on which the power generation operations ceased or will cease.
  - Incorrect. Once the licensee has made the decision to permanently cease operations, the NRC must be informed in writing within 30 days. This notification must contain the date on which the power generation operations ceased or will cease.



## Check Your Knowledge

- **Which items describe the activities a licensee may engage in after the 90-day waiting period following the submission of a PSDAR?**  
Select all that apply, then select Done.
  1. Entombing the reactor.
  2. correct: Permanent removal of major radioactive components.
  3. correct: Permanent changes to the containment structure.
  4. correct: Dismantling components resulting in "greater than Class C" waste.
- Correct. Following completion of the required submittals, and allowing for a 90-day waiting period after submittal of the PSDAR, the licensee may commence major decommissioning activities, which may include the following: permanent removal of major radioactive components (reactor vessel, steam generators, or other components that are comparably radioactive); permanent changes to the containment structure; and dismantling components resulting in "greater than Class C" waste.
- Incorrect. Following completion of the required submittals, and allowing for a 90-day waiting period after submittal of the PSDAR, the licensee may commence major decommissioning activities, which may include the following: permanent removal of major radioactive components (reactor vessel, steam generators, or other components that are comparably radioactive); permanent changes to the containment structure; and dismantling components resulting in "greater than Class C" waste.

## Methods of Decommissioning



## Decommissioning Methods

To decommission a nuclear power plant, the radioactive material on the site must be reduced to levels that would permit removal of the property from the site or termination of the NRC license. This involves removing the spent fuel, dismantling any systems or components containing activation products (such as the reactor vessel and primary systems piping), and cleaning up or dismantling contaminated materials.

The licensee decides how to decontaminate material and the decision is usually based on the amount of contamination, the ease with which it can be removed, and the cost to remove the contamination versus the cost to ship the entire structure or component to a waste-storage site. There are three methods for decommissioning: DECON, SAFSTOR, and ENTOMB.



## DECON Method

If the licensee decides on the DECON alternative, the equipment, structures, and portions of the facility and site that contain radioactive contaminants are removed or decontaminated to a level that permits termination of the license shortly after cessation of operations.

The advantages of this method are:

- The facility license is terminated quickly and the facility and site become available for other purposes
- Availability of the operating reactor personnel who are highly knowledgeable about the facility
- Elimination of the need for long-term security, maintenance, and surveillance of the facility; required for the other decommissioning alternatives
- Greater certainty about the availability of low-level waste facilities that would be willing to accept the low-level radioactive waste
- Lower estimated costs compared to the alternative of SAFSTOR; largely as a result of future price escalation because most activities that occur during DECON would also occur during the SAFSTOR period, only at a later date



### **DECON Disadvantages**

The DECON method disadvantages include:

- Higher worker and public doses (because there is less benefit from radioactive decay as would occur in the SAFSTOR option)
- A larger initial commitment of money
- A larger commitment of disposal site space than with the SAFSTOR option
- The potential for complications if spent fuel must remain on the site until a federal repository for spent fuel becomes available



## SAFSTOR Method

If the SAFSTOR alternative is chosen, the facility is maintained in a safe, stable condition until it is subsequently decontaminated and dismantled to levels permitting license termination. During SAFSTOR, a facility is left intact but the fuel is removed from the reactor vessel and radioactive liquids are drained from systems and components for processing. Some amount of radioactive decay occurs during the SAFSTOR period, thus reducing the quantity of contaminated and radioactive material that must be disposed of during decontamination and dismantlement. The SAFSTOR option includes active decommissioning at the end of the storage period.

The benefits of this method are:

- A substantial reduction in radioactivity as a result of the radioactive decay that results during the storage period
- A reduction in worker dose (as compared to the DECON) alternative
- A reduction in public exposure because of fewer shipments of radioactive material to the low-level site (as compared to the DECON alternative)
- A reduction in the amount of waste disposal space required (as compared to the DECON alternative)
- Lower cost during the years immediately following permanent cessation of operations
- A storage period compatible with the need to store spent fuel onsite



## SAFSTOR

The SAFSTOR method disadvantages are:

- A shortage of personnel familiar with the facility at the time of deferred dismantlement and decontamination
- Site is unavailable for alternate uses during the extended storage period
- Uncertainties regarding the availability and costs of low-level radioactive waste sites in the future
- Continuing need for maintenance, security, and surveillance
- Higher total cost for the subsequent decontamination and dismantlement period (assuming typical price escalation during the time the facility is stored)



## ENTOMB

If the ENTOMB option is chosen radioactive structures, systems, and components are encased in a structurally long-lived substance (e.g., concrete). The entombed structure is appropriately maintained, and continued surveillance is carried out until the radioactivity decays to a level that permits termination of the license.

The benefits of the ENTOMB process relates to the reduced amount of work in encasing the facility in a structurally long-lived substance, thus reducing the worker dose from decontaminating and dismantling the facility. In addition, public exposure from waste transported to the low-level waste site is minimized.

The ENTOMB option may have a relatively low cost. However, because most power reactors will have radionuclides in concentrations exceeding the limits for unrestricted use even after 100 years, ENTOMB is often not feasible. This option might be acceptable if the reactor facilities demonstrate that the radionuclide levels will decay allowing the NRC to grant restricted use of the site. Three small demonstration reactors have been entombed based on this methodology. Currently, no power reactor licensees have proposed the ENTOMB option for any of the power reactors undergoing decommissioning.



## Post License Termination

After the license termination occurs, the NRC issues either an unrestricted or a restricted status for the facility.

Unrestricted use of a facility after license termination means there are no restrictions on how the site may be used. The licensee is free to continue to dismantle any remaining buildings or structures and to use the land or sell the land for any type of application.

Restricted use means that the licensee has demonstrated further reductions in residual radioactivity would result in net public or environmental harm or residual levels are as low as is reasonably achievable, and the licensee made provisions for legally enforceable institutional controls (e.g., restrictions placed in the deed for the property describing what the land can and cannot be used for), which provide reasonable assurance that the radiological criteria set by the NRC will not be exceeded.



## Check Your Knowledge

**Which items identify the disadvantages associated with DECON and SAFSTOR decommissioning methods?**

Enter the number from the Answer Options in the corresponding field, then select Done.

## Answers Options:

1-DECON      2-SAFSTOR

- Site unavailable for alternate uses during the extended storage period.
- A larger initial commitment of money.
- The potential for complications if spent fuel must remain on the site until a federal repository for spent fuel becomes available.
- A shortage of personnel familiar with the facility at the time of deferred dismantlement and decontamination.
- Higher total cost for the subsequent decontamination and dismantlement period.
- Higher worker and public doses of radioactivity.

## Chapter Summary



### Key Points

- Once the licensee has made the decision to permanently cease operations, the NRC must be informed in writing within 30 days.
- The licensee must submit a post-shutdown decommissioning activities report (PSDAR) no later than 2 years after the date of permanent cessation of operations.
- After the PSDAR is submitted and a 90-day waiting period has passed, the licensee may commence major decommissioning activities.
- Concluding the decommissioning process requires the licensee to submit a License Termination Plan to the NRC.
- After the NRC determines that the remaining dismantlement has been performed in accordance with the approved License Termination Plan, the Commission will terminate the license or release non-ISFSI portions, and the decommissioning process is considered complete.





## Key Points

- There are three alternatives for decommissioning: DECON, SAFSTOR, and ENTOMB.
- If the DECON method is used the equipment, structures, and portions of the facility and site that contain radioactive contaminants are removed or decontaminated to a level that permits termination of the license shortly after cessation of operations.
- If the SAFSTOR method is used the facility is maintained in a safe, stable condition until it is subsequently decontaminated and dismantled to levels permitting license termination.
- If the ENTOMB method is used radioactive structures, systems, and components are encased in a structurally long-lived substance (e.g., concrete).



## Congratulations!

You have successfully completed the Reactor Concepts (R-100) course study material. We hope you found this course to have been beneficial.

We welcome your feedback and look for ways to improve this training in the future.

[Go To Top](#)

## Videos (MP4 Format)

[Chernobyl Accident Examined \[transcript\]](#)

[Chernobyl Explosion Aftermath \[transcript\]](#)

[Chernobyl Plant Design \[transcript\]](#)

[Chernobyl Reactor Explosion \[no transcript\]](#)

[Chernobyl Test Events \[transcript\]](#)

[Rotor Stator \[no transcript\]](#)

[Three Mile Island, Unit 2: Core Bore \[transcript\]](#)

[Three Mile Island, Unit 2: Lower Core Damage \[transcript\]](#)

[Three Mile Island, Unit 2: Plenum Damage \[transcript\]](#)

[Three Mile Island, Unit 2: Removing Lower Debris \[transcript\]](#)

[Three Mile Island, Unit 2: Removing Top Debris \[transcript\]](#)

[Three Mile Island, Unit 2: Summary \[transcript\]](#)

[Three Mile Island, Unit 2: title needed \[transcript\]](#)

[Three Mile Island, Unit 2: Upper Core Damage \[transcript\]](#)

## Acronyms

<b>ΔP</b>	differential pressure
<b>ΔT</b>	differential temperature
<b>μ</b>	micro – one millionth
<b>μci</b>	microcurie
<b>AAM</b>	airborne activity monitor
<b>AB</b>	auxiliary boiler
<b>ABB-CE</b>	Asea Brown Boveri - Combustion Engineering, Inc.
<b>ABT</b>	automatic bus transfer
<b>ABWR</b>	advanced boiling water reactor
<b>ac</b>	alternating current
<b>ACB</b>	air-operated circuit breaker
<b>ACC</b>	accumulator
<b>ACRS</b>	Advisory Committee on Reactor Safeguards
<b>ADAMS</b>	Agency-wide Documents Access and Management System
<b>ADS</b>	1) automatic depressurization system 2) automatic dispatch system
<b>ADV</b>	atmospheric dump valve
<b>AE</b>	air ejector
<b>AEDE</b>	annual effective dose equivalent
<b>AFD</b>	axial flux difference
<b>AFP</b>	auxiliary feedwater pump
<b>AFW</b>	auxiliary feedwater
<b>AFWAS</b>	auxiliary feedwater actuation system
<b>AGCR</b>	advanced gas-cooled reactor
<b>AHU</b>	air handling unit
<b>AIT</b>	augmented inspection team
<b>ALARA</b>	as low as reasonably achievable
<b>ALARP</b>	as low as reasonably practicable
<b>ALI</b>	annual level of intake
<b>ALPHGR</b>	average linear planar heat generation rate
<b>ALWR</b>	advanced light-water reactor
<b>AMSAC</b>	ATWS (anticipated transient without scram) mitigating system actuation circuitry
<b>AMU</b>	atomic mass unit
<b>ANS</b>	

	American Nuclear Society
<b>ANSI</b>	American National Standards Institute
<b>AO</b>	1) abnormal occurrence 2) auxiliary operator 3) air operator 4) axial offset
<b>AOI</b>	abnormal operating instruction
<b>AOP</b>	abnormal operating procedure
<b>AOV</b>	air-operated valve
<b>AP600</b>	Advanced Plant, 600 MWe
<b>API</b>	absolute position indication
<b>APLHGR</b>	average planar linear heat generation rate
<b>APM</b>	air particulate monitor
<b>APRM</b>	average power range monitor
<b>APSR</b>	axial power shaping rod
<b>APWR</b>	advanced pressurized-water reactor
<b>ARM</b>	area radiation monitor
<b>ARO</b>	all rods out
<b>ARP</b>	1) alarm response procedure 2) annunciator response procedure
<b>ARPI</b>	absolute rod position indication
<b>ARS</b>	acute radiation syndrome
<b>ASLAB</b>	Atomic Safety and Licensing Appeal Board
<b>ASLAP</b>	Atomic Safety and Licensing Appeal Panel
<b>ASLB</b>	Atomic Safety and Licensing Board
<b>ASLBP</b>	Atomic Safety and Licensing Board Panel
<b>ASME</b>	American Society of Mechanical Engineers
<b>ASME Code</b>	American Society of Mechanical Engineers Boiler and Pressure Vessel Code
<b>ASTM</b>	American Society for Testing and Materials
<b>ASW</b>	auxiliary service water
<b>ATOG</b>	anticipated transient operating guideline
<b>ATR</b>	advanced test reactor
<b>ATWS</b>	anticipated transient without scram
<b>AVB</b>	anti-vibration bar
<b>AVT</b>	all-volatile treatment
<b>AVV</b>	atmospheric vent valve
<b>B&amp;W</b>	Babcock & Wilcox Co. (now Framatome)

<b>B/S</b>	bistable
<b>BAST</b>	boric acid storage tank
<b>BAT</b>	1) backup auxiliary transformer 2) boric acid tank
<b>BCMS</b>	boron concentration measurement system
<b>BD</b>	blowdown
<b>BIT</b>	boron injection tank
<b>BOL</b>	beginning of life
<b>BOP</b>	balance of plant
<b>BPR</b>	burnable poison rod
<b>BPRA</b>	burnable poison rod embly
<b>BPV</b>	bypass valve
<b>Bq</b>	becquerel
<b>BRC</b>	below regulatory concern
<b>BRS</b>	boron recycle system
<b>BST</b>	boron storage tank
<b>BTRS</b>	boron thermal regeneration system
<b>BUSS</b>	backup scram system
<b>BWR</b>	boiling water reactor
<b>BWROG</b>	Boiling Water Reactor Owners Group
<b>BWST</b>	borated water storage tank
<b>C/D</b>	cooldown
<b>C/P</b>	current/pneumatic
<b>CAC</b>	1) containment atmosphere control 2) containment air cooler
<b>CANDU</b>	1) Canadian Deuterium Natural Uranium Reactor 2) Canadian Deuterium Uranium Reactor 3) Canadian Natural-Uranium, Heavy-Water-Moderated and Cooled Power Reactor
<b>CAOC</b>	constant axial offset control
<b>CAP</b>	corrective action program
<b>CAR</b>	1) condenser air removal 2) corrective action report
<b>CARS</b>	condenser air removal system
<b>CAS</b>	compressed air system
<b>CB</b>	1) containment building 2) control building
<b>CBP</b>	condensate booster pump
<b>CCDF</b>	

	conditional core damage frequency
<b>CCF</b>	common-cause failure
<b>CCGC</b>	containment combustible gas control
<b>CCP</b>	centrifugal charging pump
<b>CCW</b>	1) component cooling water 2) condenser circulating water
<b>CCWS</b>	1) component cooling water system 2) condenser circulating water system
<b>CDF</b>	core damage frequency
<b>CEA</b>	control element assembly
<b>CEAC</b>	control element assembly calculator
<b>CEADS</b>	control element assembly drive system
<b>CEDM</b>	control element drive mechanism
<b>CEDMCS</b>	control element drive mechanism control system
<b>CEDS</b>	control element drive system
<b>CEOG</b>	Combustion Engineering Owners Group
<b>CET</b>	core exit thermocouple
<b>CFC</b>	containment fan cooler
<b>CFR</b>	Code of Federal Regulations
<b>CFS</b>	1) condensate and feedwater system 2) core flood system
<b>CFT</b>	core flood tank
<b>CFW</b>	condensate and feedwater
<b>CFWS</b>	condensate and feedwater system
<b>CGCS</b>	combustible gas control system
<b>cGy</b>	centigray
<b>CHF</b>	critical heat flux
<b>CHFR</b>	critical heat flux ratio
<b>Ci</b>	curie
<b>CIA</b>	containment isolation phase A
<b>CIAS</b>	containment isolation actuation signal
<b>CIB</b>	containment isolation phase B
<b>CIS</b>	1) containment isolation signal 2) containment isolation system
<b>CIV</b>	1) combined intercept valve 2) combined intermediate valve 3) containment isolation valve
<b>CLA</b>	cold leg accumulator

<b>CLCW</b>	closed-loop cooling water
<b>CLWR</b>	commercial light-water reactor
<b>CMF</b>	1) common-mode failure 2) core-melt frequency
<b>COG</b>	condenser off-gas
<b>COL</b>	combined operating license
<b>COLR</b>	core operating limits report
<b>COLSS</b>	1) core operating limit supervisory system 2) core operating limit support system
<b>COPS</b>	cold overpressure protection system
<b>CP</b>	1) charging pump 2) containment purge 3) coolant pump
<b>CPC</b>	1) core protection calculator 2) core protection computer
<b>CPIS</b>	containment purge isolation signal
<b>cpm</b>	counts per minute
<b>CPS</b>	containment purge system
<b>cps</b>	counts per second
<b>CR</b>	1) control rod 2) control room
<b>CRA</b>	control rod assembly
<b>CRD</b>	control rod drive
<b>CRDCS</b>	control rod drive control system
<b>CRDH</b>	control rod drive hydraulic system
<b>CRDM</b>	control rod drive mechanism
<b>CRDS</b>	control rod drive system
<b>CREVS</b>	control room emergency ventilation system
<b>CRIS</b>	control room isolation signal
<b>CRO</b>	control room operator
<b>CRPI</b>	control rod position indication
<b>CRUD</b>	Chalk River unidentified deposits
<b>CS</b>	1) containment spray 2) core spray
<b>CSAS</b>	containment spray actuation signal
<b>CSCC</b>	caustic stress-corrosion cracking
<b>CSD</b>	cold shutdown
<b>CSF</b>	critical safety function

<b>CSHX</b>	containment spray heat exchanger
<b>CSIS</b>	1) containment spray injection system 2) containment spray initiation signal
<b>CSP</b>	1) containment spray pump 2) core spray pump
<b>CSRS</b>	containment spray recirculation system
<b>CSS</b>	1) condensate storage system 2) containment spray system 3) core spray system
<b>CST</b>	condensate storage tank
<b>CSTS</b>	condensate storage and transfer system
<b>CT</b>	1) cooling tower 2) current transformer
<b>CV</b>	1) check valve 2) containment vessel 3) control valve
<b>CVC</b>	chemical and volume control
<b>CVCS</b>	chemical and volume control system
<b>CVIS</b>	containment ventilation isolation signal
<b>CW</b>	circulating water
<b>CWS</b>	circulating water system
<b>D/G</b>	diesel generator
<b>D/P</b>	differential pressure
<b>D/T</b>	differential temperature
<b>DAW</b>	dry active waste
<b>DBA</b>	design-basis accident
<b>DBE</b>	1) design-basis earthquake 2) design-basis event
<b>DBLOCA</b>	design-basis loss-of-coolant accident
<b>dc</b>	direct current
<b>DE</b>	dose equivalent
<b>DEI</b>	dose equivalent iodine
<b>DET</b>	diagnostic evaluation team
<b>DF</b>	decontamination factor
<b>DFBN</b>	debris-filter bottom nozzle
<b>DG</b>	1) diesel-engine generator 2) diesel generator
<b>DGB</b>	diesel generator building
<b>DH</b>	decay heat



<b>DHR</b>	decay heat removal
<b>DHRS</b>	decay heat removal system
<b>DMW</b>	demineralized makeup water
<b>DNB</b>	departure from nucleate boiling
<b>DNBR</b>	departure from nucleate boiling ratio
<b>DP</b>	differential pressure
<b>dpm</b>	decades per minute
<b>DRA</b>	dropped rod accident
<b>DRPI</b>	1) digital rod position indication 2) digital rod position indicator
<b>DRPIS</b>	digital rod position indication system
<b>DT</b>	differential temperature
<b>DTI</b>	diagnostic team inspection
<b>DW</b>	1) demineralized water 2) drywell
<b>DWMS</b>	demineralized water makeup system
<b>DWS</b>	demineralized water system
<b>DWST</b>	demineralized water store
<b>E/P</b>	electrical to pneumatic
<b>EA</b>	enforcement action
<b>EAB</b>	exclusion area boundary
<b>EAG</b>	emergency action guidelines
<b>EAL</b>	1) emergency action level 2) equipment air lock
<b>EAP</b>	emergency action plan
<b>EC</b>	eddy current
<b>ECA</b>	emergency contingency action
<b>ECCS</b>	emergency core cooling system
<b>ECCW</b>	emergency core cooling water
<b>ECI</b>	essential controls and instrumentation
<b>ECP</b>	estimated critical position
<b>ECT</b>	eddy current test
<b>ECW</b>	emergency cooling water
<b>ED/G</b>	emergency diesel generator
<b>EDG</b>	emergency diesel generator
<b>EFAS</b>	1) emergency feedwater actuation signal

	2) emergency feedwater actuation system
<b>EFIC</b>	emergency feedwater initiation and control
<b>EFP</b>	electric fire pump
<b>EFPD</b>	1) effective full-power day 2) equivalent full-power day
<b>EFPH</b>	effective full-power hour
<b>EFS</b>	emergency feedwater system
<b>EFW</b>	emergency Feedwater
<b>EFWS</b>	emergency feedwater system
<b>EFWST</b>	emergency feedwater storage tank
<b>EG</b>	emergency generator
<b>EHC</b>	electrohydraulic control
<b>EHR</b>	emergency heat removal
<b>EI</b>	1) emergency injection 2) engineering instruction
<b>EOC</b>	1) emergency operations center 2) end of cycle
<b>EOC-RPT</b>	end-of-cycle recirculation pump trip
<b>EOF</b>	emergency operations facility
<b>EOI</b>	emergency operating instruction
<b>EOL</b>	end of life
<b>EOP</b>	1) emergency operating plan 2) emergency operating procedure
<b>EP</b>	1) emergency plan 2) emergency procedure
<b>EPG</b>	emergency procedure guideline
<b>EPRI</b>	Electric Power Research Institute
<b>EPZ</b>	emergency planning zone
<b>EQ</b>	1) environmental qualification 2) environmentally qualified 3) equipment qualification
<b>ERCW</b>	1) emergency raw cooling water 2) essential raw cooling water
<b>ERCWS</b>	emergency raw cooling water system
<b>ERF</b>	emergency response facility
<b>ESF</b>	engineered safety feature
<b>ESFA</b>	engineered safety feature actuation
<b>ESFAS</b>	engineered safety features actuation signal
<b>ESW</b>	1) emergency service water

2) essential service water

**ESWS**

1) emergency service water system

2) essential service water system

**F/A**

fuel assembly

**F/D**

filter/demineralizer

**FA**

fuel assembly

**FAI**

fail as is

**FBR**

fast breeder reactor

**FC**

1) fail closed

2) flow controller

3) fuel cycle

**FCI**

fuel coolant interaction

**FCV**

flow control valve

**FDW**

feedwater

**FE**

1) flow element

2) fuel element

**FERP**

fire emergency response plan

**FFE**

full field exercise

**FHB**

fuel handling building

**FI**

flow indicator

**FIFO**

first in, first out

**FME**

foreign material exclusion

**FO**

fail open

**FOGG**

feed-only-good generator

**FP**

1) fire protection

2) fission product

3) full power

**FPCCS**

fuel pool cooling and cleanup system

**FPD**

full-power day

**FPS**

fire protection system

**FSAR**

final safety analysis report

**FSF**

fuel storage facility

**FSSAR**

final standard safety analysis report

**FT**

flow transmitter

**FTA**

fault tree analysis

**FTC**

fuel temperature coefficient

**FW**

feedwater

**FWC**

feedwater control

<b>FWCS</b>	feedwater control system
<b>FWIV</b>	feedwater isolation valve
<b>FWLB</b>	feedwater line break
<b>FWRV</b>	feedwater regulating valve
<b>FWS</b>	1) feedwater supply 2) feedwater system
<b>FWST</b>	fueling water storage tank
<b>gBq</b>	gigabecquerel
<b>GDC</b>	general design criterion
<b>GDP</b>	gaseous diffusion plant
<b>GDT</b>	gas decay tank
<b>GET</b>	general employee training
<b>GI</b>	1) gastrointestinal 2) generic issue
<b>GIF</b>	gamma irradiation facility
<b>GL</b>	generic letter
<b>GM</b>	Geiger-Mueller
<b>GN</b>	general notice
<b>GOI</b>	general operating instruction
<b>GS</b>	gland seal
<b>GSC</b>	1) gland seal condenser 2) gland steam condenser
<b>GSER</b>	generic safety evaluation report
<b>GSI</b>	generic safety issue
<b>Gy</b>	gray
<b>H&amp;V</b>	heating and ventilation
<b>H/A</b>	hand/automatic
<b>H/U</b>	heatup
<b>HCS</b>	1) hydrazine control system 2) hydrogen control system
<b>HCU</b>	hydraulic control unit
<b>HCV</b>	1) hand control valve 2) hydraulic control valve
<b>HE</b>	human error
<b>HEPA</b>	high efficiency particulate air (filter)
<b>HEPB</b>	high energy pipe break
<b>HEU</b>	highly enriched uranium

<b>HEX</b>	uranium hexafluoride
<b>HFE</b>	human factors engineering
<b>HFP</b>	hot full power
<b>HFT</b>	hot functional testing
<b>HG</b>	hydrogen gas
<b>HG/NG</b>	hydrogen gas/nitrogen gas
<b>HHSI</b>	high head safety injection
<b>HLW</b>	1) high level liquid waste 2) high level radioactive waste 3) high level waste
<b>HM</b>	heavy metal
<b>HO</b>	hydraulic operator
<b>HOV</b>	hydraulically operated valve
<b>HP</b>	1) health physicist 2) health physics 3) high pressure
<b>HPCI</b>	high pressure coolant injection
<b>HPCIS</b>	high pressure coolant injection system
<b>HPCS</b>	high pressure core spray
<b>HPI</b>	high pressure injection
<b>HPIS</b>	high pressure injection system
<b>HPR</b>	high pressure recirculation
<b>HPRS</b>	high pressure recirculation system
<b>HPSI</b>	high pressure safety injection
<b>HPSIP</b>	high pressure safety injection pump
<b>HPSP</b>	high power set point
<b>HPT</b>	high pressure turbine
<b>HPU</b>	hydraulic power unit
<b>HR</b>	hydrogen recombiner
<b>HS</b>	hand switch
<b>HSP</b>	hot shutdown panel
<b>HTGCR</b>	high-temperature gas-cooled reactor
<b>HTGR</b>	1) high-temperature gas-cooled reactor 2) high temperature gas reactor
<b>HTV</b>	half thickness value
<b>HU</b>	hydraulic unit
<b>HUT</b>	holdup tank

<b>HV</b>	1) hand valve 2) high voltage
<b>HVAC</b>	heating, ventilation, and air conditioning
<b>HVD</b>	heaters, vents, and drains
<b>Hvdc</b>	high-voltage direct current
<b>HW</b>	1) heavy water 2) hot water 3) hotwell
<b>HWGCR</b>	heavy-water-moderated, gas-cooled reactor
<b>HWLC</b>	hotwell level control
<b>HWR</b>	heavy water reactor
<b>HX</b>	1) heat exchange 2) heat exchanger
<b>HZP</b>	hot zero power
<b>I&amp;C</b>	instrumentation and control
<b>I/A</b>	isolation amplifier
<b>I/O</b>	input/output
<b>IA</b>	instrument air
<b>IAL</b>	immediate action letter
<b>IAS</b>	instrument air system
<b>IASCC</b>	irradiation-assisted stress-corrosion cracking
<b>ICC</b>	inadequate core cooling
<b>ID</b>	1) inner diameter 2) inside diameter
<b>IE</b>	initiating event
<b>IFBA</b>	integral fuel burnable absorber
<b>IFM</b>	intermediate flow mixing
<b>IGA</b>	intergranular attack
<b>IGSCC</b>	intergranular stress-corrosion cracking
<b>IHSI</b>	intermediate head safety injection
<b>IHX</b>	intermediate heat exchanger
<b>IM</b>	1) instrumentation and measurement 2) integrated master
<b>IMS</b>	in-core monitoring system
<b>IN</b>	information notice
<b>INPO</b>	Institute of Nuclear Power Operations
<b>INR</b>	immediate notification report
<b>INX</b>	

	ion exchange
<b>IP</b>	inspection procedure
<b>IPE</b>	individual plant examination
<b>IPEEE</b>	individual plant examination of external events
<b>IR</b>	1) information request 2) inspection report 3) intermediate range
<b>IRB</b>	inside reactor building
<b>IRC</b>	1) incident response center 2) inside reactor containment
<b>IRM</b>	intermediate-range monitor
<b>IRP</b>	incident response plan
<b>IRPI</b>	individual rod position indicator
<b>ISFSF</b>	independent spent fuel storage facility
<b>ISFSI</b>	independent spent fuel storage installation
<b>ISGTR</b>	induced steam generator tube rupture
<b>ISI</b>	inservice inspection
<b>ISLOCA</b>	interfacing-systems loss-of-coolant accident
<b>IST</b>	1) inservice test 2) inservice testing 3) integral systems test
<b>ISTS</b>	Improved Standard Technical Specifications
<b>ITAAC</b>	inspection, test, analysis, and acceptance criterion/criteria
<b>ITC</b>	isothermal temperature coefficient
<b>ITM</b>	in-core temperature monitor
<b>ITMS</b>	in-core temperature monitoring system
<b>IX</b>	ion exchanger
<b>JCO</b>	justification for continued operation
<b>JTA</b>	job task analysis/analyses
<b>K</b>	kilo - thousand
<b>K/A</b>	knowledge and abilities
<b>Keff</b>	effective multiplication factor
<b>KSAs</b>	knowledge, skills, and abilities
<b>Kv</b>	kilovolt
<b>Kw</b>	kilowatt
<b>L/M</b>	local manual
<b>LA</b>	local alarm
<b>LAR</b>	

- 1) license amendment request
- 2) licensing action report

**LBE**

licensing-basis event

**LBLOCA**

large-break loss-of-coolant accident

**LBP**

lumped burnable poison

**LBPR**

lumped burnable poison rod

**LC**

- 1) level controller
- 2) local control
- 3) locked closed

**LCO**

limiting condition for operation

**LCRM**

linear count rate meter

**LCS**

level control system

**LCV**

- 1) level control valve
- 2) local control valve

**LD**

- 1) letdown
- 2) lethal dose

**LDR**

low dose rate

**LDS**

leakage detection system

**LER**

licensee event report

**LEU**

low enriched uranium

**LH**

low head

**LHGR**

linear heat generation rate

**LHR**

linear heat rate

**LHSI**

low-head safety injection

**LI**

level indicator

**LIFO**

last in, first out

**LLD**

low-level dose

**LLRW**

low-level radioactive waste

**LLW**

- 1) low-level radioactive waste
- 2) low-level waste

**LMTD**

logarithmic mean temperature difference

**LN<sub>2</sub>**

liquid nitrogen

**LNT**

linear, no-threshold

**LO**

- 1) lock open
- 2) locked open
- 3) lube oil

**LOA**

local operator action

**LOCA**

loss-of-coolant accident

**LOCA**

loss of coolant accident



<b>LOCF</b>	loss of coolant flow
<b>LOCV</b>	loss of condenser vacuum
<b>LOF</b>	1) loss of feedwater 2) loss of flow
<b>LOFA</b>	1) loss-of-feedwater accident 2) loss-of-flow accident
<b>LOFC</b>	1) loss of forced circulation 2) loss of forced cooling
<b>LOFW</b>	loss of feedwater
<b>LOHS</b>	loss of heat sink
<b>LOMF</b>	loss of main feedwater
<b>LOMFW</b>	loss of main feedwater
<b>LOOP</b>	loss of offsite power
<b>LOP</b>	loss of offsite power
<b>LOPAR</b>	low parasitic fuel
<b>LOSP</b>	1) loss of offsite power 2) loss of station power 3) loss of system pressure
<b>LOST</b>	lube oil storage tank
<b>LP</b>	low pressure
<b>LPCI</b>	1) low-pressure coolant injection 2) low-pressure core injection
<b>LPCIS</b>	low-pressure coolant injection system
<b>LPCS</b>	low-pressure core spray
<b>LPD</b>	1) linear power density 2) local power density
<b>LPI</b>	low-pressure injection
<b>LPIS</b>	low-pressure injection system
<b>LPMA</b>	loose-parts-monitor assembly
<b>LPMS</b>	loose-parts monitoring system
<b>LPRM</b>	1) local power range monitor 2) low-power range monitor
<b>LPRS</b>	low-pressure recirculation system
<b>LPSI</b>	low-pressure safety injection
<b>LPSIP</b>	low-pressure safety injection pump
<b>LPSP</b>	low-power set point
<b>LPT</b>	1) liquid penetrant testing 2) low-pressure turbine
<b>LPZ</b>	low-population zone

<b>LRA</b>	locked-rotor accident
<b>LS</b>	1) level switch 2) locked shut
<b>LSA</b>	low specific activity
<b>LSP</b>	level set point
<b>LSSS</b>	limiting safety system setting
<b>LT</b>	level transmitter
<b>LTD</b>	letdown
<b>LTMD</b>	less than minimum detectable
<b>LTOP</b>	low-temperature overpressure protection
<b>LVDT</b>	linear variable differential transformer
<b>LWR</b>	light-water reactor
<b>m</b>	milli - one thousandth
<b>M</b>	mega - million
<b>M/A</b>	manual/automatic
<b>MAD</b>	modulating atmospheric dump
<b>MAN</b>	manual
<b>MAPLHGR</b>	1) maximum average planar linear heat generation 2) maximum average planar linear heat generation ratio
<b>MAR</b>	maintenance action request
<b>MB</b>	mixed bed
<b>Mbq</b>	megabecquerel
<b>MC</b>	main condenser
<b>MCB</b>	main control board
<b>MCC</b>	motor control center
<b>MCHFR</b>	1) minimum critical flux rate 2) minimum critical heat ratio
<b>mCi</b>	millicurie
<b>MCPR</b>	1) maximum critical power ratio 2) minimum critical power ratio
<b>MCR</b>	main control room
<b>MDA</b>	minimum detectable activity
<b>MDAFWP</b>	motor-driven auxiliary feedwater pump
<b>MDC</b>	1) maximum dependable capacity 2) minimum detectable concentration
<b>MDCT</b>	mechanical draft cooling tower
<b>MDEFWP</b>	motor-driven emergency feedwater pump

<b>MDL</b>	minimum detectable limit
<b>MDNBR</b>	minimum departure from nucleate boiling ratio
<b>MDU</b>	motion detection unit
<b>MEU</b>	medium-enriched uranium
<b>MeV</b>	million electron volts
<b>MFC</b>	master flow controller
<b>MFCS</b>	main feedwater control system
<b>MFIS</b>	main feedwater isolation signal
<b>MFIV</b>	main feedwater isolation valve
<b>MFP</b>	main feedwater pump
<b>MFPT</b>	main feedwater pump turbine
<b>MFRV</b>	main feedwater regulation valve
<b>MFS</b>	main feedwater system
<b>MFV</b>	main feedwater valve
<b>MFW</b>	main feedwater
<b>MFWCS</b>	main feedwater and condensate system
<b>MFWLB</b>	main feedwater line break
<b>MFWRV</b>	main feedwater regulating valve
<b>MFWV</b>	main feedwater valve
<b>MG</b>	motor generator
<b>MHTGR</b>	modular high-temperature gas-cooled reactor
<b>MIC</b>	1) microbiologically induced corrosion 2) microbiologically influenced corrosion
<b>MICDS</b>	movable in-core detector system
<b>MIDS</b>	movable instrument drive System
<b>MLHGR</b>	1) maximum linear heat generation rate 2) maximum linear heat generation ratio
<b>MLO</b>	main lube oil
<b>MLW</b>	mean low water
<b>MO</b>	1) mixed oxide 2) modulate open 3) motor operated
<b>MOA</b>	memorandum/memoranda of agreement
<b>MOC</b>	1) middle of cycle 2) minimum operable channels
<b>MODE</b>	maximum organ dose equivalent
<b>MOU</b>	memorandum/memoranda of understanding

<b>MOV</b>	motor-operated valve
<b>MOVATS</b>	motor-operated valve analysis and test system
<b>MOX</b>	mixed oxide
<b>MOXF</b>	mixed oxide fuel
<b>MPAI</b>	maximum permissible annual intake
<b>MPBB</b>	maximum permissible body burden
<b>MPC</b>	maximum permissible concentration
<b>MPCA</b>	maximum permissible concentration in air
<b>MPCW</b>	maximum permissible concentration in water
<b>MPD</b>	maximum permissible dose
<b>MPE</b>	maximum permissible exposure
<b>MPL</b>	maximum permissible level
<b>mps</b>	meters per second
<b>mREM</b>	millirem
<b>MRS</b>	monitorable, retrievable storage
<b>MRSS</b>	main and reheat steam system
<b>MS</b>	main steam
<b>MSB</b>	1) main steamline break 2) multi-assembly sealed basket
<b>MSICV</b>	main steam isolation check valve
<b>MSIS</b>	main steam isolation signal
<b>MSIV</b>	main steam isolation valve
<b>MSL</b>	1) main steamline 2) mean sea level
<b>MSLA</b>	main steamline accident
<b>MSLB</b>	main steamline break
<b>MSLI</b>	main steamline isolation
<b>MSR</b>	moisture, separator reheater
<b>MSRV</b>	main steam relief valve
<b>MSS</b>	1) main steam system 2) main support structure 3) modified scram system
<b>MSSR</b>	main steam safety relief (valve)
<b>MSSS</b>	1) main steam supply system 2) main steam support structure
<b>MSSV</b>	main steam safety valve
<b>MTBF</b>	mean time between failures

<b>MTC</b>	1) minimum temperature for criticality 2) moderator temperature coefficient
<b>MTF</b>	mean time to failure
<b>MTG</b>	main turbine generator
<b>MTPF</b>	maximum total peaking factor
<b>MTTF</b>	mean time to failure
<b>MTTR</b>	1) mean time to repair 2) mean time to replacement
<b>MTU</b>	metric tons of uranium
<b>MU</b>	makeup
<b>MU&amp;P</b>	makeup and purification
<b>MUT</b>	makeup tank
<b>mV</b>	millivolt
<b>MVP</b>	mechanical vacuum pump
<b>MW</b>	megawatt
<b>MWe</b>	Megawatt- electric
<b>MWO</b>	maintenance work order
<b>MWS</b>	makeup water system
<b>MWST</b>	1) makeup water storage tank 2) miscellaneous waste storage tank
<b>MWt</b>	megawatt thermal
<b>MWth</b>	Megawatt - thermal
<b>NC</b>	normally closed
<b>NCV</b>	non-cited violation
<b>NDCT</b>	natural draft cooling tower
<b>NDE</b>	non-destructive examination
<b>NDT</b>	1) nil ductility temperature 2) non-destructive testing
<b>NDTT</b>	nil ductility transition temperature
<b>NI</b>	1) nuclear instrument 2) nuclear instrumentation
<b>NIS</b>	nuclear instrumentation system
<b>NNI</b>	non-nuclear instrumentation
<b>NNIS</b>	non-nuclear instrumentation system
<b>NO</b>	normally open
<b>NOD</b>	notice of deviation
<b>NOP</b>	1) normal operating procedure

	2) normal operating pressure
<b>NOT</b>	normal operating temperature
<b>NOUE</b>	1) notice of unusual event 2) notification of unusual event
<b>NOV</b>	notice of violation
<b>NPO</b>	nuclear plant operator
<b>NPP</b>	nuclear power plant
<b>NPR</b>	non-power reactor
<b>NPSH</b>	net positive suction head
<b>NRC</b>	Nuclear Regulatory Commission
<b>NRHE</b>	non-regenerative heat exchanger
<b>NRHX</b>	non-regenerative heat exchanger
<b>NS</b>	normally shut
<b>NSCW</b>	nuclear service cooling water
<b>NSO</b>	nuclear station operator
<b>NSR</b>	non-safety related
<b>NSS</b>	nuclear steam system
<b>NSSS</b>	nuclear steam supply system
<b>NSSSS</b>	nuclear steam supply shutoff system
<b>NSW</b>	nuclear service water
<b>NSWS</b>	nuclear service water system
<b>NTE</b>	not to exceed
<b>NTP</b>	normal operating temperature and pressure
<b>NTR</b>	nuclear test reactor
<b>O&amp;M</b>	operation and maintenance (cost)
<b>OBE</b>	operating-basis earthquake
<b>OCB</b>	oil cooled circuit breaker
<b>OD</b>	outside diameter
<b>ODCM</b>	offsite dose calculation manual
<b>ODSCC</b>	1) outer-diameter stress-corrosion cracking 2) outside-diameter stress-corrosion cracking
<b>OEM</b>	original equipment manufacturer
<b>OER</b>	operating event report
<b>OERTS</b>	operational events report tracking system
<b>OFA</b>	optimized fuel assembly
<b>OG</b>	1) off-gas

2) owners group

**OGS**  
off-gas system

**OI**  
1) operating instruction  
2) optical isolator

**OLMCPR**  
operating limit maximum critical power ratio

**OOS**  
1) out of sequence  
2) out of service

**OPS**  
1) overpressure protection system  
2) overpressurization protection system  
3) operations (department)

**ORB**  
outside reactor building

**ORC**  
outside reactor containment

**ORR**  
operational readiness review

**OTC**  
once-through cooling

**OTM**  
overspeed trip mechanism

**OTSG**  
once-through steam generator

**p**  
pico - one million-millionth

**P&I**  
piping and instrumentation

**P&ID**  
piping and instrumentation diagram

**P/T**  
pressure and temperature

**PAMS**  
post-accident monitoring system

**PARV**  
1) power-activated relief valve  
2) power-actuated relief valve

**PASS**  
post-accident sampling system

**PBR**  
pebble bed reactor

**PCB**  
power circuit breaker

**pci**  
picocurie

**PCIS**  
primary containment isolation system

**PCIV**  
primary containment isolation valve

**PCS**  
1) plant computer system  
2) plant control system  
3) power conversion system  
4) pressure control system  
5) primary coolant system

**PCT**  
1) peak centerline temperature  
2) peak cladding temperature

**PCV**  
1) pressure control valve  
2) pressurizer control valve

**PDL**  
power distribution limit

**PDP**  
positive displacement pump

**PDS**

	1) plant damage state
	2) power distribution system
<b>PEO</b>	plant equipment operator
<b>PER</b>	problem event report
<b>PERMS</b>	process and effluent radiological monitoring system
<b>PERMSS</b>	process and effluent radiological monitoring and sampling system
<b>PFCS</b>	primary flow control system
<b>PFS</b>	private fuel storage
<b>PFSF</b>	private fuel storage facility
<b>PHD</b>	pulse height discriminator
<b>PI</b>	1) performance indicator
	2) pressure indicator
	3) proportional-integral
<b>PID</b>	proportional-integral-derivative
<b>PIS</b>	1) pressure-indicating switch
	2) process instrumentation system
<b>PIV</b>	pressure isolation valve
<b>PLOCAP</b>	post-loss-of-coolant-accident protection
<b>PLS</b>	precautions, limitations, and setpoints
<b>PM</b>	preventive maintenance
<b>PMIS</b>	plant monitoring and information system
<b>PMP</b>	preventive maintenance procedure
<b>PMS</b>	1) plant monitoring system
	2) primary makeup system
<b>PMU</b>	plant makeup
<b>PN</b>	preliminary notification
<b>PNO</b>	preliminary notification of occurrence
<b>POAH</b>	point of adding heat
<b>POP</b>	peak overpressure
<b>POPS</b>	pressurizer overpressure protection system
<b>PORV</b>	1) pilot-operated relief valve
	2) power-operated relief valve
<b>PORV</b>	power operated relief valve; pilot operated relief valve
<b>POS</b>	1) plant operating system
	2) plant operational state
<b>PP</b>	primary pressure
<b>PPIS</b>	plant protection and instrumentation system
<b>ppm</b>	parts per million
<b>pps</b>	



	pulses per second
<b>PR</b>	power range
<b>PRA</b>	1) probabilistic risk analysis/analyses 2) probabilistic risk assessment
<b>PRG</b>	procedure review group
<b>PRM</b>	1) power range monitor 2) process radiation monitor
<b>PRMS</b>	process radiation monitoring system
<b>PRT</b>	pressurizer relief tank
<b>PRV</b>	pressure relief valve
<b>PS</b>	pressure switch
<b>PSAR</b>	preliminary safety analysis report
<b>PSMS</b>	plant safety monitoring system
<b>PSS</b>	1) primary sampling system 2) process sampling system
<b>PSV</b>	pressurizer safety valve
<b>PSW</b>	plant service water
<b>PSWS</b>	potable and sanitary water system
<b>PT</b>	1) periodic test 2) periodic testing 3) pre-operational test 4) pre-operational testing 5) pressure and temperature 6) pressure transmitter
<b>PTS</b>	pressurized thermal shock
<b>PW</b>	potable water
<b>PWR</b>	pressurized water reactor
<b>PWR</b>	pressurized water reactor
<b>PWROG</b>	Pressurized-Water Reactor Owners Group
<b>PWSCC</b>	primary water stress corrosion cracking
<b>PZR</b>	pressurizer
<b>QA</b>	quality assurance
<b>QC</b>	quality control
<b>QF</b>	quality factor
<b>QPT</b>	quadrant power tilt
<b>QPTR</b>	quadrant power tilt ratio
<b>rad</b>	radiation absorbed dose
<b>RADCON</b>	radiological control (department)
<b>RAOC</b>	relaxed axial offset control

<b>RAT</b>	reserve auxiliary transformer
<b>RB</b>	reactor building
<b>RBC</b>	reactor building cooling
<b>RBCCW</b>	reactor building closed cooling water
<b>RBCS</b>	reactor building cooling system
<b>RBCU</b>	reactor building cooling unit
<b>RBCW</b>	reactor building cooling water
<b>RBFC</b>	reactor building fan cooler
<b>RBM</b>	rod-block monitor
<b>RBPVS</b>	reactor building purge ventilation system
<b>RBS</b>	reactor building spray
<b>RC</b>	1) reactor cavity 2) reactor coolant
<b>RCA</b>	1) radiological controlled area 2) reactor coolant activity 3) root cause analysis
<b>RCAP</b>	root cause analysis program
<b>RCB</b>	reactor containment building
<b>RCBT</b>	reactor coolant bleed tank
<b>RCC</b>	rod cluster control
<b>RCCA</b>	rod cluster control assembly
<b>RCCS</b>	reactor cavity cooling system
<b>RCDT</b>	reactor coolant drain tank
<b>RCFC</b>	reactor containment fan cooler
<b>RCIC</b>	reactor core isolation cooling
<b>RCICS</b>	reactor core isolation cooling system
<b>RCIS</b>	rod control and information system
<b>RCMU</b>	reactor coolant makeup
<b>RCP</b>	reactor coolant pump
<b>RCPB</b>	reactor coolant pressure boundary
<b>RCS</b>	reactor coolant system
<b>RCW</b>	raw cooling water
<b>RDA</b>	rod drop accident
<b>RDS</b>	reactor depressurization system
<b>RDT</b>	reactor drain tank
<b>RE</b>	1) radiation equipment

	2) radiation element
<b>REA</b>	rod ejection accident
<b>rem</b>	roentgen equivalent man
<b>REP</b>	1) radiological emergency plan 2) resonance escape probability
<b>RESAR</b>	reference safety analysis report
<b>RFC</b>	recirculation flow control
<b>RFCS</b>	recirculation flow control system
<b>RFP</b>	reactor feed pump
<b>RFPT</b>	reactor feed pump turbine
<b>RH</b>	relative humidity
<b>RHR</b>	residual heat removal
<b>RHRP</b>	residual heat removal pump
<b>RHRS</b>	residual heat removal system
<b>RHT</b>	recycle holdup tank
<b>RHX</b>	regenerative heat exchanger
<b>RI</b>	1) radiation indicator 2) NRC resident inspector
<b>RM</b>	1) radiation monitor 2) radiation monitoring 3) remote manual
<b>RMC</b>	remote manual control
<b>RMCS</b>	1) reactor makeup control system 2) reactor manual control system
<b>RMS</b>	1) radiation monitoring system 2) radiological monitoring system 3) remote manual switch
<b>RMW</b>	reactor makeup water
<b>RMWS</b>	reactor makeup water storage
<b>RMWST</b>	reactor makeup water storage tank
<b>RMWT</b>	reactor makeup water tank
<b>RNDT</b>	reference nil ductility temperature
<b>RO</b>	reactor operator
<b>RP</b>	1) radiation protection 2) reactor pressure
<b>RPB</b>	reactor pressure boundary
<b>RPC</b>	rotating pancake coil
<b>RPI</b>	relative position indication
<b>RPIS</b>	1) rod position indication system

	2) rod position information system
<b>RPS</b>	reactor protection system
<b>RPT</b>	recirculation pump trip
<b>RPV</b>	reactor pressure vessel
<b>RRA</b>	risk reduction analysis/analyses
<b>RRP</b>	reactor recirculation pump
<b>RRPI</b>	relative rod position indication
<b>RRS</b>	1) reactor recirculation system 2) reactor regulating system
<b>RRW</b>	risk reduction worth
<b>RS</b>	recirculation spray
<b>RSA</b>	remote shutdown area
<b>RSCS</b>	rod sequence control system
<b>RSE</b>	reserve shutdown equipment
<b>RSO</b>	radiation safety officer
<b>RSP</b>	remote shutdown panel
<b>RSS</b>	1) reactor shutdown system 2) remote shutdown system
<b>RSSF</b>	retrievable surface storage facility
<b>RSST</b>	reserve station service transformer
<b>RSW</b>	raw service water
<b>RT</b>	1) reactor trip 2) reference temperature
<b>RT<sub>ndt</sub></b>	nil ductility reference temperature
<b>RTB</b>	reactor trip breaker
<b>RTCB</b>	reactor trip circuit breaker
<b>RTD</b>	resistance temperature detector
<b>RTM</b>	reactor trip module
<b>RTP</b>	rated thermal power
<b>RTS</b>	reactor trip system
<b>RTT</b>	reference transition temperature
<b>RV</b>	1) reactor vessel 2) relief valve
<b>RVIS</b>	reactor vessel instrumentation system
<b>RVLIS</b>	reactor vessel level instrumentation system
<b>RVLM</b>	reactor vessel level monitoring
<b>RVRLIS</b>	reactor vessel refueling level indication system

**RW**

- 1) raw water
- 2) river water

**RWB**

rod withdrawal block

**RWC**

reactor water cleanup

**RWCS**

reactor water cleanup system

**RWCU**

reactor water cleanup

**RWL**

- 1) reactor water level
- 2) rod withdrawal limiter

**RWM**

rod worth minimizer

**RWP**

radiation work permit

**RWS**

radwaste system

**RWSP**

refueling water storage pool

**RWST**

refueling water storage tank

**S/D**

shutdown

**S/G**

steam generator

**S/R**

safety relief

**S/U**

startup

**SA**

service air

**SAE**

site area emergency

**SALP**

systematic assessment of licensee performance

**SAMG**

severe accident management guidelines

**SAR**

safety analysis report

**SART**

site access refresher training

**SAS**

- 1) service air system
- 2) station air system

**SAT**

- 1) site access training
- 2) spray additive tank
- 3) startup auxiliary transformer
- 4) station auxiliary transformer

**SBCS**

steam bypass control system

**SBGT**

standby gas treatment

**SBGTS**

standby gas treatment system

**SBLC**

standby liquid control

**SBLOCA**

small-break loss-of-coolant accident

**SBO**

station blackout

**SBWR**

simplified boiling water reactor

**SCAT**

spray chemical addition tank

**SCC**

	stress corrosion cracking
<b>scfh</b>	standard cubic feet per hour
<b>scfm</b>	standard cubic feet per minute
<b>SCHE</b>	shutdown cooling heat exchanger
<b>SCHES</b>	shutdown cooling heat exchanger subsystem
<b>SCI</b>	secondary containment isolation
<b>SCIV</b>	secondary containment isolation valve
<b>SCO</b>	senior control (room) operator
<b>SCPPCS</b>	secondary containment purge and pressure control system
<b>SCR</b>	silicon-controlled rectifier
<b>SCRO</b>	senior control room operator
<b>SCS</b>	shutdown cooling system
<b>SCSHX</b>	shutdown cooling system heat exchanger
<b>SCST</b>	spray chemical storage tank
<b>SCWHE</b>	shutdown cooling water heat exchanger
<b>SCWS</b>	shutdown cooling water subsystem
<b>SD</b>	1) scram discharge 2) shutdown
<b>SDBCS</b>	steam dump bypass control system
<b>SDC</b>	shutdown cooling
<b>SDCS</b>	shutdown cooling system
<b>SDG</b>	standby diesel generator
<b>SDHR</b>	shutdown decay heat removal
<b>SDHX</b>	shutdown heat exchanger
<b>SDM</b>	shutdown margin
<b>SDS</b>	steam dump system
<b>SDV</b>	1) scram discharge volume 2) steam dump valve
<b>SDVIV</b>	scram discharge volume instrument volume
<b>SE</b>	1) shift engineer 2) significant event (NRC performance indicator)
<b>SEN</b>	Significant Event Notification (INPO)
<b>SEP</b>	1) site emergency plan 2) standby electric power
<b>SER</b>	1) safety evaluation report 2) significant event report
<b>SET</b>	Special Evaluation Team
<b>SFA</b>	

- 1) single-failure analysis/analyses
- 2) spent fuel assembly
- 3) standard fuel assembly

**SFAS**

safety features actuation signal

**SFCS**

spent fuel cooling system

**SFP**

- 1) spent fuel pit
- 2) spent fuel pool

**SFPC**

spent fuel pool cooling

**SFPCCS**

spent fuel pool cooling and cleanup system

**SFPCCS**

spent fuel pool cooling system

**SFRCS**

steam and feedwater rupture control system

**SFS**

steam and feedwater system

**SFSP**

spent fuel storage pool

**SG**

steam generator

**SGB**

steam generator blowdown

**SGBD**

steam generator blowdown

**SGBS**

Steam generator blowdown system

**SGFP**

steam generator feedwater pump

**SGIS**

safeguards initiation signal

**SGTR**

steam generator tube rupture

**SGTS**

standby gas treatment system

**SGWLC**

steam generator water level control

**SHRS**

shutdown heat removal system

**SI**

- 1) safety injection
- 2) special instruction
- 3) surveillance inspection
- 4) surveillance instruction

**SIAS**

safety injection actuation signal

**SIRWT**

safety injection and refueling water tank

**SIS**

- 1) safety injection signal
- 2) safety injection system

**SIT**

safety injection tank

**SJAE**

steam jet-air ejector

**SL**

safety limit

**SLB**

steamline break

**SLC**

standby liquid control

**SLCS**

standby liquid control system

**SLI**

steamline isolation

**SLIV**

	steamline isolation valve
<b>SMM</b>	subcooling margin monitor
<b>SNM</b>	special nuclear material
<b>SNUPPS</b>	standardized nuclear unit power plant system
<b>SO</b>	supervising operator
<b>SOE</b>	sequence of events
<b>SOL</b>	senior operator license
<b>SOM</b>	shift operations manager
<b>SOS</b>	shift operations supervisor
<b>SOV</b>	solenoid-operated valve
<b>SP</b>	1) setpoint 2) suppression pool 3) surveillance procedure
<b>SPC</b>	1) standby pressure control 2) suppression pool cooling
<b>SPDS</b>	safety parameter display system
<b>SPGD</b>	self-powered gamma detector
<b>SPND</b>	self-powered neutron detector
<b>SR</b>	1) safety related 2) safety rod 3) source range 4) surveillance requirement
<b>SRD</b>	self-reading dosimeter
<b>SRFM</b>	source range flux monitor
<b>SRI</b>	NRC senior resident inspector
<b>SRM</b>	source range monitor
<b>SRO</b>	senior reactor operator
<b>SRS</b>	solid radwaste system
<b>SRST</b>	spent resin storage tank
<b>SRT</b>	spent resin tank
<b>SRV</b>	safety/relief valve
<b>SRWS</b>	solid radioactive waste system
<b>SSE</b>	safe-shutdown earthquake
<b>SSLPS</b>	solid-state logic protection system
<b>SSPI</b>	safety system performance indicator
<b>SSPS</b>	solid-state protection system
<b>SST</b>	station service transformer
<b>SSW</b>	1) salt service water



2) standby service water

**SSWP**

station service water pump

**SSWS**

1) standby service water system

2) station service water system

**STA**

shift technical advisor

**STE**

1) shift technical engineer

2) system test engineer

**STP**

1) special technical publication

2) standard temperature and pressure

3) surveillance test procedure

4) system test procedure

**STS**

Standard Technical Specifications

**SUR**

startup rate

**SV**

1) safety valve

2) solenoid valve

3) stop valve

**Sv**

sievert

**SW**

service water

**SWCS**

salt water cooling system

**SWGR**

switchgear

**SWGTS**

steam and waste gas treatment system

**SWIS**

service water intake structure

**SWMS**

solid waste management system

**SWP**

service water pump

**SWPS**

solid waste processing system

**SWS**

1) service water system

2) solid waste system

**T/C**

thermocouple

**T/G**

turbine generator

**T/H**

thermal and hydraulic

**TAF**

top of active fuel

**TB**

turbine building

**TBCCW**

turbine building closed cooling water

**TBS**

turbine bypass system

**TBSCCW**

turbine building secondary closed cooling water

**TBSW**

turbine building service water

**TBV**

1) turbine block valve

2) turbine building ventilation

3) turbine bypass valve

**TCS**

turbine control system

**TCV**

- 1) temperature control valve
- 2) turbine control valve

**TD**

- 1) time delay
- 2) turbine driven

**TDAFP**

turbine-driven auxiliary feedwater pump

**TDAFW**

turbine-driven auxiliary feedwater

**TDAFWP**

turbine-driven auxiliary feedwater pump

**TDEFWP**

turbine-driven emergency feedwater pump

**TDH**

- 1) total developed head
- 2) total dynamic head

**TDP**

turbine-driven pump

**TDS**

total dissolved solids

**TE**

temperature element

**TEDE**

total effective dose equivalent

**TFC**

thermal fatigue crack

**TFS**

turbine first stage

**TG**

turbine generator

**TGB**

turbine generator building

**TGS**

turbine generator system

**TGSCC**

transgranular stress corrosion cracking

**TGSS**

turbine gland sealing system

**TGV**

turbine governor valve

**TI**

- 1) temperature indicator
- 2) temporary instruction
- 3) test instruction
- 4) transport index

**TID**

total integrated dose

**TIP**

traversing in-core probe

**TLD**

thermoluminescence dosimeter

**TLO**

turbine lube oil

**TLOFW**

total loss of feedwater

**TLOS**

turbine lube oil system

**TLOST**

turbine lube oil storage tank

**TM**

- 1) technical manual
- 2) temperature monitor

**TMI**

Three Mile Island

**TP**

test procedure

**TPCDF**

total plant core damage frequency

<b>TPF</b>	total peaking factor
<b>TR</b>	temperature recorder
<b>TS</b>	technical specification
<b>TSC</b>	technical support center
<b>TSP</b>	1) trisodium phosphate 2) tube support plate
<b>TSV</b>	turbine stop valve
<b>TSW</b>	turbine service water
<b>TT</b>	1) temperature transmitter 2) turbine trip
<b>TTV</b>	tenth thickness value
<b>UAT</b>	unit auxiliary transformer
<b>UDS</b>	ultimate damage state
<b>UFSAR</b>	updated final safety analysis report
<b>UHI</b>	upper-head injection
<b>UHS</b>	ultimate heat sink
<b>UHV</b>	ultrahigh voltage
<b>ULD</b>	unit load demand
<b>UO</b>	unit operator
<b>UPS</b>	uninterruptible power supply
<b>USI</b>	unresolved safety issue
<b>UT</b>	1) ultrasonic test 2) ultrasonic testing
<b>UV</b>	undervoltage
<b>V%</b>	volume percent
<b>Vac</b>	volts alternating current
<b>VAR</b>	volt amperes reactive
<b>VCT</b>	volume control tank
<b>Vdc</b>	volts direct current
<b>w%</b>	weight percent
<b>WABA</b>	wet annular burnable assembly
<b>WAPA</b>	wet annular poison assembly
<b>WB</b>	whole body
<b>WG</b>	waste gas
<b>WGC</b>	waste gas compressor
<b>WGDS</b>	waste gas disposal system

<b>WGDT</b>	waste gas decay tank
<b>WGS</b>	waste gas system
<b>WHT</b>	waste holdup tank
<b>WMS</b>	waste management system
<b>WOG</b>	Westinghouse Owners Group
<b>WP</b>	work procedure
<b>WPS</b>	waste processing system
<b>WR</b>	wide range
<b>WTF</b>	waste treatment facility
<b>WTP</b>	water treatment plant
<b>WW</b>	well water
<b>WWS</b>	well water system
<b>WWTF</b>	waste water treatment facility

## Glossary

### Absorber

Any material that lessens the intensity of ionizing radiation by causing the radiation to deposit its energy in the material. Neutron absorbers (like boron, hafnium, and cadmium) are used in control rods for reactors. Concrete and steel absorb gamma rays and neutrons in reactor shields. A thin sheet of paper or metal will absorb alpha particles and low energy beta particles.

### Absorption

The process by which the number of particles or photons entering a body of matter is reduced by interaction with matter. Also the process in which energy is absorbed from the particles or photons even if the number is not reduced.

### Access Hatch

An airtight door system that preserves the pressure integrity of a reactor containment building while allowing access to personnel and equipment.

### Activation

The process of making a radioisotope by bombarding a stable element with neutrons, protons, or other nuclear radiation.

### Active Fuel Length

The end-to-end dimension of fuel material within a fuel element.

### Airborne Radioactivity Area

A room, enclosure, or area in which airborne radioactive materials, composed wholly or partly of licensed material, exist in concentrations that:

1. Exceed the derived air concentration limits, or
2. Would result in an individual present in the area without respiratory protection exceeding, during the hours the individual is present in the area during the week, 0.6% of the annual limit on intake or 12 DAC-hours.

### ALARA

Acronym for "As Low As is Reasonably Achievable," means making every reasonable effort to maintain exposures to radiation as far below the dose limits as practical consistent with the purpose for which the licensed activity is undertaken, taking into account the state of technology, the economics of improvements in relation to state of technology, the economics of improvements in relation to benefits to the public health and safety, and other societal and socioeconomic considerations, and in relation to utilization of nuclear energy and licensed materials in the public interest.

### Alpha Particle

A positively-charged particle ejected spontaneously from the nuclei of some radioactive elements. It is identical to a helium nucleus (atomic mass number = 4) and an electrostatic charge of +2. It has low penetrating power and generally short ranges. The most energetic alpha particle will generally fail to penetrate the dead layer of cells covering the skin. Alphas are significant internal hazard.

### Anion

A negatively charged ion.

### Annual Limit on Intake (ALI)

The derived limit for the amount of radioactive material taken into the body of an adult worker by inhalation or ingestion in a year. ALI is the smaller value of intake of a given radionuclide in a year by the reference man that would result in a committed effective dose equivalent of 5 rems (0.05 Sv) or a committed dose equivalent of 50 rems (0.5 Sv) to any individual organ or tissue.

### Atom

The smallest particle of an element that cannot be divided or broken up by chemical means. It consists of a central core of protons and neutrons, called the nucleus. Electrons revolve in orbits in the region surrounding the nucleus.

### Atomic Energy

Energy released in nuclear reactions. Of particular interest is the energy released when a neutron initiates the breaking up or fissioning of an atom's nucleus into smaller pieces (fission), or when two nuclei are joined together under millions of degrees of heat (fusion). It is more correctly called nuclear energy.

### Atomic Energy Commission (AEC)

Federal agency created in 1946 to manage the development, use, and control of nuclear energy for military and civilian application. Abolished by the Energy Reorganization Act of 1974 and succeeded by the Energy Research and Development Administration (now part of the U.S. Department of Energy) and the U.S. Nuclear Regulatory Commission.

### Atomic Number

The number of protons in the nucleus of an atom.

### Attenuation

The process by which the number of particles or photons entering a body of matter is reduced by absorption and scatter.

### Auxiliary Building

Building at a nuclear power plant, frequently located adjacent to the reactor containment building, that houses most of the reactor auxiliary and safety systems, such as radioactive waste systems, chemical and volume control system, and emergency cooling water systems.

### Auxiliary Feedwater (AFW)

Backup feedwater supply used during nuclear plant startup and shutdown and is the supply of water to the steam generators during accident conditions for removing decay heat from the reactor.

#### **Average Planar Linear Heat Generation Rate (APLGR)**

The average value of the linear heat generation rate of all the rods at any given horizontal plane along a fuel bundle.

#### **Axial Flux Difference**

The difference in normalized flux signals between the top and bottom halves of a two section excore neutron detector.

#### **Background Radiation**

Radiation from cosmic sources, naturally occurring radioactive materials (including radon, except as a decay product of source or special nuclear material), and global fallout as it exists in the environment from the testing of nuclear explosive devices. It does not include source, byproduct, or special nuclear materials regulated by the Commission. The typically quoted average individual exposure from background radiation is 360 millirem per year.

#### **Becquerel (Bq)**

The unit of radioactive decay equal to 1 disintegration per second.  $3.7 \times 10^{10}$  Bq = 1 Curie.

#### **Beta Particle**

A charged particle emitted from a nucleus during radioactive decay. It is physically like an electron (mass = 1/1837 that of a proton), but may be positively (positron), rather than negatively, charged. Beta radiation can be both an external and internal hazard. Beta particles may be stopped by thin sheets of metal or plastic.

#### **Binding Energy**

The minimum energy required to separate a nucleus into its component neutrons and protons.

#### **Bioassay**

The determination of kinds, quantities or concentrations, and in some cases, the locations of radioactive material in the human body, whether by direct measurement (in vivo counting) or by analysis and evaluation of materials excreted or removed from the human body.

#### **Biological Half-life**

The time required for a biological system, such as that of a human, to eliminate, by natural processes, half of the amount of a substance (such as a radioactive material) that has entered it.

#### **Biological Shielding**

A mass of absorbing material placed around a reactor or radioactive source to reduce the radiation to a level safe for humans.

#### **Boiling Water Reactor (BWR)**

A reactor in which water, used as both coolant and moderator, is allowed to boil in the core. The resulting steam can be used directly to drive a turbine and electrical generator.

#### **Bone Seeker**

A radioisotope that tend to accumulate in the bones when it is introduced into the body. An example is strontium-90, which behaves chemically like calcium.

#### **Breeder**

A reactor that produced more nuclear fuel than it consumes. A fertile material, such as uranium-238, when bombarded by neutrons, is transformed into a fissile material, such as plutonium-239, which can be used as a fuel. *See also:* fissile, fissionable, fertile material.

#### **Btu**

A British thermal unit. The amount of heat required to change the temperature of one pound of water one degree Fahrenheit at sea level.

#### **Calibration**

The adjustment, as necessary, of a measuring device such that it responds within the required range and accuracy to known values of input.

#### **Cask**

A heavily shielded container used to store and/or ship radioactive materials. Lead and steel are common materials used in the manufacture of casks.

#### **Cation**

A positively charged ion.

#### **Chain Reaction**

A reaction that stimulates its own repetition. In a fission chain reaction, a fissionable nucleus absorbs a neutron and fissions, releasing additional neutrons. These, in turn, can be absorbed by other fissionable nuclei, releasing still more neutrons. A fission chain reaction is self-sustaining when the number of neutrons released in a given time equals or exceeds the number of neutrons lost by absorption in non-fissionable material or by escape from the system.

#### **Charged Particle**

An ion. An elementary particle carrying a positive or negative electric charge.

#### **Chemical Recombination**

Following an ionization event, the positively and negatively charged ion pairs may or may not realign themselves to form the same chemical substance they formed before ionization. Thus, chemical recombination could change the chemical composition of the material bombarded by radiation.

#### **Cladding**

The thin-walled metal tube that forms the outer jacket of a nuclear fuel rod. It prevents the corrosion of the fuel by the coolant and the release of fission products in the coolant. Aluminum, stainless steel, and zirconium alloys are common cladding materials. Cladding is considered the first barrier to fission products.

#### **Cleanup System**

A system used for continuously filtering and demineralizing the reactor coolant system to reduce contamination levels and to minimize corrosion.

**Coastdown**

An action that permits the reactor power level to decrease gradually as the fuel in the core is depleted.

**Cold Shutdown**

The term used to define a reactor coolant system at atmospheric pressure and at a temperature below 200°F following a reactor cooldown.

**Compound**

A chemical combination of two or more elements combined in a fixed and definite proportion by weight.

**Condensate**

Water that has been produced by the cooling of steam in a condenser.

**Condenser**

A large heat exchanger designed to cool exhaust steam from a turbine below the boiling point so that it can be returned to the heat source as water. In a pressurized water reactor, the water is returned to the steam generator. In a boiling water reactor, it returns to the reactor core. The heat removed from the steam by the condenser is transferred to a circulating water system and is exhausted to the environment, either through a cooling tower or directly into a body of water.

**Containment**

The provision of a gas-tight shell or other enclosure around a reactor to confine fission products that otherwise might be released to the atmosphere in the event of an accident.

**Contamination**

The deposition of unwanted radioactive material on the surfaces of structures, areas, objects, or personnel. It may also be airborne or internal (inside components or personnel).

**Control Rod**

A rod, plate, or tube containing a material such as hafnium, boron, etc., used to control the power of a nuclear reactor. By absorbing neutrons, a control rod prevents the neutrons from causing further fissions.

**Control Room Building**

The area in a nuclear power plant from which most of the plant power production and emergency safety equipment can be operated by remote control.

**Controlled Area**

An area outside of a restricted area but within the site boundary, access to which can be limited by the licensee for any reason.

**Coolant**

A substance circulated through a nuclear reactor to remove or transfer heat. The most commonly used coolant in the United States is water. Other coolants include heavy water, air, carbon dioxide, helium, liquid sodium, and a sodium-potassium alloy.

**Cooldown**

The gradual decrease in reactor fuel rod temperature caused by the removal of heat from the reactor coolant system.

**Cooling Tower**

A heat exchanger designed to aid in the cooling of water that was used to cool exhaust steam exiting the turbines of a power plant. Cooling towers transfer exhaust heat into the air instead of into a body of water.

**Core**

The central portion of a nuclear reactor containing the fuel elements, moderator, neutron poisons, and support structures.

**Core Melt Accident**

An event or sequence of events that result in the melting of part of the fuel in the reactor core.

**Cosmic Radiation**

Penetrating ionizing radiation, both particulate and electromagnetic, originating in outer space. Secondary cosmic rays, formed by interactions in the earth's atmosphere, account for about 45 to 50 millirems of the 360 millirems background radiation that an average individual receives in a year.

**Counter**

A general designation applied to radiation detection instruments or survey meters that detect and measure radiation. The signal that announces an ionization event is called a count.

**Critical Mass**

The smallest mass of fissionable material that will support a self-sustaining chain reaction.

**Criticality**

A term used in reactor physics to describe the state when the number of neutrons released by fission is exactly balanced by the neutrons being absorbed (by the fuel and poisons) and escaping the reactor core. A reactor is said to be "critical" when it achieves a self-sustaining nuclear chain reaction.

**Crud**

A colloquial term for corrosion and wear products (rust particles, etc.) that become radioactive (i.e., activated) when exposed to radiation. The term is actually an acronym for Chalk River Unidentified Deposits, the Canadian plant at which the activated deposits were first discovered.

**Cumulative Dose**

The total dose resulting from repeated exposures of radiation to the same portion of the body, or to the whole body, over a period of time.

**Curie (Ci)**

The basic unit used to describe the intensity of radioactivity in a sample of material. The curie is equal to 37 billion

disintegrations per second, which is approximately the rate of decay of 1 gram of radium. A curie is also the quantity of any radionuclide that decays at a rate of 37 billion disintegrations per second. The curie is named for Marie and Pierre Curie, who discovered radium in 1898.

### **Daughter Products**

Isotopes that are formed by the radioactive decay of some other isotope. In the case of radium-226, for example, there are 10 successive daughter products, ending in the stable isotope lead-206.

### **Decay Heat (DH)**

The heat produced by the decay of radioactive fission products after the reactor has been shut down.

### **Decay, Radioactive**

The spontaneous transformation of any radioactive material with the passage of time causing the emission of ionizing radiation (e.g. alpha, beta, gamma, etc.). The decay may result in a daughter product that is also radioactive.

### **Declared Pregnant Woman**

A woman who has voluntarily informed her employer, in writing, of her pregnancy and the estimated date of conception.

### **Decontamination**

The reduction or removal of contaminating radioactive material from a structure, area, object, or person. Decontamination may be accomplished by:

1. Treating the surface to remove or decrease the contamination
2. Letting the material stand so that the radioactivity is decreased by natural decay
3. Covering the contamination to shield the radiation emitted

### **Demineralizer**

A tank containing resin beads that will remove bad ions from the water and replace them with more desirable ions, usually those that will combine to make pure water.

### **Departure from Nucleate Boiling**

The point at which the heat transfer from a fuel rod rapidly decreases due to the insulating effect of a steam blanket that forms on the rod surface.

### **Departure from Nucleate Boiling Ratio (DNBR)**

The ratio of the heat flux required to cause departure from nucleate boiling to the actual local heat flux.

### **Depleted Uranium**

Uranium having a percentage of uranium-235 smaller than the 0.7% found in natural uranium. It is obtained from spent (used) fuel elements or as byproduct tails, or residues, from uranium isotope separation.

### **Derived Air Concentration (DAC)**

The concentration of a given radionuclide in air, which if breathed by the reference man for a working year of 2,000 hours under conditions of light work (inhalation of 1.2 cubic meters of air per hour), results in an intake of one ALI.

### **Design-Basis Accident**

A postulated accident that a nuclear facility must be designed and built to withstand without loss to the systems, structures, and components necessary to assure public health and safety.

### **Design-Basis Phenomena**

Earthquakes, tornadoes, hurricanes, floods, etc., that a nuclear facility must be designed and built to withstand without loss of systems, structures, and components necessary to assure public health and safety.

### **Detector**

A material or device that is sensitive to radiation and can produce a response signal suitable for measurement or analysis. A radiation detection instrument.

### **Deuterium**

An isotope of hydrogen with one proton and one neutron in the nucleus.

### **Deuteron**

The nucleus of deuterium. It contains one proton and one neutron.

### **Differential Pressure (dp or $\Delta P$ )**

The difference in pressure between two points of a system, such as between the inlet and outlet of a pump.

### **Doppler Coefficient**

Another name used for the fuel temperature coefficient of reactivity.

### **Dose**

The absorbed dose, given in rads or grays, that represents the energy absorbed from the radiation in a gram of any material. Furthermore, the biological dose or dose equivalent, given in rems or Sieverts, is a measure of the biological damage to living tissue from the radiation exposure.

### **Dose Equivalent**

A term used to express the amount of biologically effective radiation dose when modifying factors have been considered. The product of absorbed dose, a quality factor, and a distribution factor. It is expressed numerically in rems or Sieverts.

### **Dose Rate**

The radiation dose delivered per unit time, for example, rem per hour.

### **Dose, Absorbed**

The amount of energy deposited in any substance by ionizing radiation per unit mass of the substance. It is expressed numerically in rads or grays.

### **Dosimeter**



A portable instrument for measuring and registering the total accumulated dose to ionizing radiation.

### **Dosimetry**

The theory and application of the principles and techniques involved in the measurement and recording of radiation doses.

### **Drywell**

The containment structure enclosing a boiling water reactor vessel and its recirculation system. The drywell provides both a pressure suppression system and a fission product barrier under accident conditions.

### **Effective Halflife**

The time required for the amount of a radioactive element deposited in a living organism to be diminished 50% as a result of the combined action of radioactive decay and biological elimination.

### **Efficiency, Plant**

The percentage of the total energy content of a power plant's fuel that is converted into electricity. The remaining energy is lost to the environment as heat.

### **Electrical Generator**

An electromagnetic device that converts mechanical (rotational) energy into electrical energy. Most large electrical generators are driven by steam or water turbine systems.

### **Electromagnetic Radiation**

A traveling wave motion resulting from changing electric or magnetic fields. Familiar electromagnetic radiations range from x-rays (and gamma rays) of short wavelength, through the ultraviolet, visible, and infrared regions, to radar and radio waves of relatively long wave lengths. All electromagnetic radiations travel in a vacuum at the velocity of light.

### **Electron**

An elementary particle with a negative charge and a mass 1/1837 that of the proton. Electrons surround the positively charged nucleus and determine the chemical properties of the atom.

### **Element**

One of the 113 known chemical substances that cannot be broken down further without changing its chemical properties. Some examples include hydrogen, nitrogen, oxygen, gold, lead, and uranium.

### **Emergency Core Cooling Systems (ECCS)**

Reactor system components (pumps, valves, heat exchangers, tanks, and piping) that are specifically designed to remove residual heat from the reactor fuel rods should the normal core cooling system (reactor coolant system) fail.

### **Emergency Feedwater**

A name that may be used for auxiliary feedwater

### **Exclusion Area**

That area surrounding the reactor, in which the reactor licensee has the authority to determine all activities, including the exclusion or removal of personnel and property from the area.

### **Excursion**

A sudden, very rapid rise in the power level of the reactor caused by supercriticality. Excursions are usually quickly suppressed by the negative fuel temperature coefficient, the moderator temperature coefficient, or the void coefficient (depending upon reactor design), and by rapid insertion of the control rods.

### **Exposure**

Being exposed to ionizing radiation or to radioactive material.

### **External Radiation**

Exposure to ionizing radiation when the radiation source is located outside the body.

### **Extremities**

The hands, forearms, elbows, feet, knee, leg below the knee, and ankles. The permissible radiation exposures in these regions are generally greater than in the whole body because they contain less blood forming organs and have smaller volumes for energy absorption.

### **Fast Fission**

Fission of a heavy atom (such as uranium-238) when it absorbs a high energy (fast) neutron. Most fissionable materials need thermal (slow) neutrons in order to fission.

### **Fast Neutron**

A neutron released during fission with kinetic energy greater than its surroundings.

### **Fast Reactor**

A reactor in which the fission chain reaction is sustained primarily by fast neutrons rather than by slow moving neutrons. Fast reactors contain little or no moderator to slow down the neutrons from the speeds at which they are ejected from the fissioning nuclei.

### **Feedwater (FDW)**

Water supplied to the reactor pressure vessel (in a BWR) or the steam generator (in a PWR) that removes heat from the reactor fuel rods by boiling and becoming steam. The steam becomes the driving force for the plant's turbine generator.

### **Fertile Material**

A material, which is not itself fissile (fissionable by thermal neutrons), that can be converted into a fissile material by irradiation in a reactor. There are two basic fertile materials, uranium-238 and thorium-232. When these fertile materials capture neutrons, they are converted into fissile plutonium-239 and uranium-233, respectively.

### **Film Badge**

A pack of photographic film used for measurement of radiation exposure for personnel monitoring purposes. The badge may contain two or three films of differing sensitivities, and it may contain a filter that shields part of the film from certain types of radiation.

**Fissile Material**

Although sometimes used as a synonym for fissionable material, this term has acquired a more restricted meaning. Namely, any material fissionable by thermal (slow) neutrons. The three primary fissile materials are uranium-233, uranium-235, and plutonium.

**Fission**

The splitting of a nucleus into at least two other nuclei and the release of a relatively large amount of energy. Two or three neutrons are usually released during this type of transformation.

**Fission Gases**

Those fission products that exist in the gaseous state, primarily the noble gases (krypton, xenon, etc.).

**Fission Products**

The nuclei (fission fragments) formed by the fission of heavy elements, plus the nuclide formed by the fission fragments' radioactive decay.

**Fissionable Material**

Commonly used as a synonym for fissile material, the meaning of this term has been extended to include material that can be fissioned by fast neutrons, such as uranium-238.

**Flux**

A term applied to the amount of some type of particle (neutrons, alpha radiation, etc.) or energy (photons, heat, etc.) crossing a unit area per unit time. The unit of flux is the number of particles, energy, etc., per square centimeter per second.

**Fuel Assembly**

A cluster of fuel rods (or plates). Also called a fuel element. Many fuel assemblies make up a reactor core.

**Fuel Cycle**

The series of steps involved in supplying fuel for nuclear power reactors. It can include mining, milling, isotopic enrichment, fabrication of fuel elements, use in a reactor, chemical reprocessing to recover the fissionable material remaining in the spent fuel, re-enrichment of the fuel material, refabrication into new fuel elements, and waste disposal.

**Fuel Reprocessing**

The processing of reactor fuel to separate the unused fissionable material from waste material.

**Fuel Rod**

A long, slender tube that holds fissionable material for nuclear reactor use. Fuel rods are assembled into bundles called fuel elements or fuel assemblies, which are loaded individually into the reactor core.

**Fuel Temperature Coefficient of Reactivity**

The change in reactivity per degree change in the fuel temperature. The physical property of fuel pellet material (uranium-238) that causes the uranium to absorb more neutrons away from the fission process as fuel pellet temperature increases. This acts to stabilize power reactor operations. This coefficient is also known as the Doppler coefficient.

**Fusion (thermonuclear reaction)**

A nuclear reaction characterized by the joining together of light nuclei to form heavier nuclei, the energy for the reaction being provided by violent thermal agitation of particles at very high temperatures. If the colliding particles are properly chosen and the agitation is violent enough, there will be a release of energy from the reaction. The energy of the stars is derived from such reactions.

**Gamma Ray (gamma radiation)**

High-energy, short wavelength, electromagnetic radiation (a packet of energy) emitted from the nucleus. Gamma radiation frequently accompanies alpha and beta emissions and always accompanies fission. Gamma rays are very penetrating and are best stopped or shielded by dense materials, such as lead or uranium. Gamma rays are similar to x-rays.

**Gap**

The space inside a reactor fuel rod that exists between the fuel pellet and the fuel rod cladding.

**Gas-Cooled Reactor**

A nuclear reactor in which a gas is the coolant.

**Gaseous Diffusion (plant)**

A method of isotopic separation based on the fact that gas atoms or molecules with different masses will diffuse through a porous barrier (or membrane) at different rates. This method is used to separate uranium-235 from uranium-238. It requires large gaseous diffusion plants and enormous amounts of electrical power.

**Gases**

Normally, formless fluids that completely fill the space, and take the shape of, their container.

**Geiger-Mueller Counter**

A radiation detection and measuring instrument. It consists of a gas-filled tube containing electrodes, between which there is an electrical voltage, but no current flowing. When ionizing radiation passes through the tube, a short, intense pulse of current passes from the negative electrode to the positive electrode and is measured or counted. The number of pulses per second measures the intensity of the radiation field. It was named for Hans Geiger and W. Mueller, who invented it in the 1920's. It is sometimes called simply a Geiger counter or a G-M counter.

**Graphite**

A form of carbon, similar to the lead used in pencils, used as a moderator in some nuclear reactors.

**Gray (Gy)**

The unit of absorbed radiation dose equal to 1 Joule/kilogram. 1 Gy = 100 rad.

**Half-life**

The time in which one half of the atoms of a particular radioactive substance disintegrate into another nuclear

form. Measured half-lives vary from millionths of a second to billions of years; also called physical or radiological half-life.

### **Half-life, Biological**

The time required for the body to eliminate one half of the material taken in by natural biological means.

### **Half-life, Effective**

The time required for a radionuclide contained in a biological system, such as a human or an animal, to reduce its activity by one half as a combined result of radioactive decay and biological elimination.

### **Half-thickness**

The thickness of any given absorber that will reduce the intensity of a beam of radiation to one half of its initial value.

### **Head, Reactor Vessel**

The removable top section of a reactor pressure vessel. It is bolted in place during power operation and removed during refueling to permit access of fuel handling equipment to the core.

### **Health Physics**

The science concerned with recognition, evaluation, and control of health hazards from ionizing radiation.

### **Heat Exchanger**

Any device that transfer heat from one fluid (liquid or gas) to another fluid or to the environment.

### **Heat Sink**

Anything that absorbs heat, usually part of the environment, such as the air, river, or outer space.

### **Heatup**

The rise in temperature of the reactor fuel rods resulting from an increase in the rate of fission in the core.

### **Heavy Water (D<sub>2</sub>O)**

Water containing significantly more than the natural proportions (one in 6,500) of heavy hydrogen (deuterium) atoms to ordinary hydrogen atoms. Heavy water is used as a moderator in some reactors because it slows down neutrons effectively and also has a low probability of absorption of neutrons.

### **Heavy Water Moderated Reactor**

A reactor that uses heavy water as its moderator. Heavy water is an excellent moderator and thus permits the use of inexpensive (unenriched) uranium as a fuel.

### **High Radiation Area**

Any area with dose rates greater than 100 mrem in one hour 30 cm from the source or from any surface through which the radiation penetrates. These areas must be posted as high radiation areas and access into these areas is maintained under strict control.

### **Hot**

A colloquial term meaning highly radioactive.

### **Hot Spot**

The region in a radiation/contamination area in which the level of radiation/contamination is noticeably greater than in neighboring regions in the area.

### **Induced Radioactivity**

Radioactivity that is created when stable substances are bombarded by ionizing radiation. For example, the stable isotope cobalt-59 becomes the radioactive isotope cobalt-60 under neutron bombardment.

### **Internal Radiation**

Nuclear radiation resulting from radioactive substances in the body. Some examples are iodine-131 (found in the thyroid gland) and strontium-90 and plutonium-239 (found in bone).

### **Ion**

1. An atom that has too many or too few electrons, causing it to have an electrical charge, and therefore, be chemically active.
2. An electron that is not associated (in orbit) with a nucleus.

### **Ionization**

The process of creating ions by adding one or more electrons to, or removing one or more electrons from, atoms or molecules. High temperatures, electrical discharges, or nuclear radiations can cause ionizations.

### **Ionization Chamber**

An instrument that detects and measures ionizing radiation by measuring the electrical current that flows when ionizing radiation ionizes gas in a chamber, making the gas a conductor of electricity.

### **Ionizing Radiation**

Any radiation capable of displacing electrons from atoms or molecules, thereby producing ions. Some examples are alpha, beta, gamma, x-rays, neutrons, and ultraviolet light. High doses of ionizing radiation may produce severe skin or tissue damage.

### **Irradiation**

Exposure to radiation.

### **Isotone**

One of several different nuclides having the same number of neutrons in their nuclei.

### **Isotope**

Isotopes occur when an element's atoms exist with different numbers of neutrons. Recall that elements are defined by the number of protons in the nucleus. Thus, carbon-12, carbon-13, and carbon-14 are isotopes of the element carbon, the numbers denoting the approximate atomic weights. Isotopes generally have the same chemical properties, but often different physical properties (for example, carbon-12 and carbon-13 are stable, carbon-14 is radioactive).

**Isotope Separation**

The process of separating isotopes from one another, or changing their relative abundances, as by gaseous diffusion or electromagnetic separation. Isotope separation is a step in the isotopic enrichment process.

**Isotopic Enrichment**

A process by which the relative abundance of the isotopes of a given element is altered, thus producing a form of the element that has been enriched in one particular isotope and depleted in its other isotopic forms.

**Kilo-**

A prefix that multiplies a basic unit by 1,000.

**Kilovolt**

The unit of electrical potential equal to 1,000 volts.

**Kinetic Energy**

The energy that a body possesses by virtue of its mass and velocity. Also called the energy of motion.

**Lethal Dose 50/60 (LD 50/60)**

The dose of radiation expected to cause death within 60 days to 50% of those exposed. Generally accepted to range from 400 to 450 rem received over a short period of time.

**Licensee**

Any person or entity that applies to, and is authorized by, the NRC to conduct any of the following:

- Construct, operate, and decommission commercial reactors and fuel cycle facilities.
- Possess, use, process, export, and import nuclear materials and waste, and handle certain aspects of their transportation.
- Site, design, construct, operate, and close waste disposal sites.

**Light Water**

Ordinary water (H<sub>2</sub>O) as distinguished from heavy water (D<sub>2</sub>O).

**Light Water Reactor**

A term used to describe reactors using ordinary water as coolant, including boiling water reactors (BWRs) and pressurized water reactors (PWRs), the most common type used in the United States.

**Limiting Condition for Operation**

The section of Technical Specifications that identifies the lowest functional capability or performance level of equipment required for safe operation of the facility.

**Limiting Safety System Settings**

Settings for automatic protective devices related to those variables having significant safety functions. Where a limiting safety system setting is specified for a variable on which a safety limit has been placed, the setting will assure that automatic protective action will correct the abnormal situation before a safety limit is exceeded.

**Linear Heat Generation Rate**

The heat generation rate per unit length of fuel rod, commonly expressed in kilowatts per foot of fuel rod (kw/ft).

**Loop**

In a pressurized water reactor, the coolant flow path through piping from the reactor pressure vessel to the steam generator, to the reactor coolant pump, and back to the reactor pressure vessel. Large PWRs may have as many as four separate loops.

**Loss of Coolant Accident (LOCA)**

Those postulated accidents that result in a loss of reactor coolant at a rate in excess of the capability of the reactor makeup system from breaks in the reactor coolant pressure boundary, up to and including a break equivalent to the double-ended rupture of the largest pipe of the reactor coolant system.

**Low Population Zone (LPZ)**

An area of low population density often required around a nuclear installation. The number and density of residents is of concern in emergency planning so that certain protective measures (such as notification and instructions to residents) can be accomplished in a timely manner.

**Mass Number**

The number of nucleons (neutrons and protons) in the nucleus of an atom. Also known as the atomic weight of an atom.

**Mass-Energy Equation**

The equation developed by Albert Einstein which is usually given as:

$$E=mc^2$$

showing that, when the energy of a body changes by an amount  $E$  (no matter what form the energy takes), the mass,  $m$ , of the body will change by an amount equal to  $E/c^2$ . The factor  $c^2$ , the square of the speed of light in a vacuum, may be regarded as the conversion factor relating units of mass and energy. The equation predicted the possibility of releasing enormous amounts of energy by the conversion of mass to energy. It is also called the Einstein Equation.

**Maximum Exposed Organ**

The body organ receiving the highest radiation dose.

**Mega-**

A prefix that multiplies a basic unit by 1,000,000.

**Megacurie**

One million curies.

**Micro-**

A prefix that divides a basic unit into one million parts.

**Microcurie**

One millionth of a curie.

**Microsecond**

One millionth of a second.

**Mill Tailings**

Natural radioactive residue from the processing of uranium ore into yellowcake in a mill. Although the milling process recovers about 93% of the uranium, the residues, or tailings, contain several radioactive elements, including uranium, thorium, radium, polonium, and radon.

**Milli-**

A prefix that divides a basic unit by 1,000.

**Millirem**

One thousandth of a rem.

**Milliroentgen**

One thousandth of a roentgen.

**Moderator**

A material that is used in a reactor to slow down high-velocity neutrons, thus increasing the likelihood of fission. Sample moderators include ordinary water, heavy water, or graphite.

**Moderator Temperature Coefficient of Reactivity**

The change in reactivity per degree change in moderator temperature due to the property of reactor moderator to slow down fewer neutrons as its temperature increases. This acts to stabilize power reactor operations.

**Molecule**

A group of atoms held together by chemical forces. A molecule is the smallest unit of a compound that can exist by itself and retain all of its chemical properties.

**Monitoring**

Periodic or continuous determination of the amount of ionizing radiation or radioactive contamination present in an occupied region, as a safety measure, for the purpose of health protection.

**Nano-**

A prefix that divides a basic unit by one billion.

**Nanocurie**

One billionth of a curie.

**Natural Circulation**

The circulation of the coolant in the reactor coolant system without the use of the reactor coolant pumps. The circulation is due to the natural convection resulting from the different densities of relative cold and heated portions of the system.

**Natural Uranium**

Uranium as found in nature. It contains 0.7% uranium-235, 99.3% uranium-238, and a trace of uranium.

**Neutron**

An uncharged elementary particle with a mass slightly greater than that of the proton, and found in the nucleus of every atom heavier than hydrogen.

**Neutron Capture**

The process in which an atomic nucleus absorbs or captures a neutron.

**Neutron Chain Reaction**

A process in which some of the neutrons released in one fission event cause other fissions to occur. There are three types of chain reactions:

1. Non-sustaining chain reaction - An average of less than one fission is produced by the neutrons released by each previous fission (reactor subcriticality).
2. Sustaining chain reaction - An average of exactly one fission is produced by the neutrons released by each previous fission (reactor criticality).
3. Multiplying chain reaction - An average of more than one fission is produced by the neutrons released by previous fission (reactor supercriticality).

**Neutron Flux**

The number of neutrons passing through a unit area per second.

**Neutron Generation**

The release, thermalization, and absorption of fission neutrons by a fissile material and the fission of that material producing a second generation of neutrons. In a typical reactor system, there are about 40,000 generations of neutrons every second.

**Neutron Leakage**

Neutrons that escape from the vicinity of the fissionable material in a reactor core. Neutrons that leak out of the fuel region are no longer available to cause fission and must be absorbed by shielding placed around the reactor pressure vessel for that purpose.

**Neutron Source**

A radioactive material (decays by neutron emission) that can be inserted into a reactor to ensure that a sufficient quantity of neutrons is available to register on neutron detection equipment for power level indication.

**Neutron, Thermal**

A neutron that has (by collision with other particles) reached an energy state equal to that of its surroundings.

**Noble Gas**

A gaseous chemical element that does not readily enter into chemical combination with other elements, such as an inert gas.

### **Non-Vital Plant System**

Systems at a nuclear facility that may or may not be necessary for the operation of the facility (i.e., power production), but that would have little or no effect on public health and safety should they fail. These systems are not safety related.

### **Nozzle**

As used in PWRs and BWRs, the interface for fluid (inlet and outlet) between reactor plant components (pressure vessel, coolant pumps, steam generators, etc.) and their associated piping systems.

### **Nuclear Energy**

The energy liberated by a nuclear reaction (fission or fusion) or by radioactive decay.

### **Nuclear Force**

A powerful, short-ranged, attractive force that holds together the particles inside an atomic nucleus.

### **Nuclear Power Plant**

An electrical generating facility using a nuclear reactor as its power (heat) source.

### **Nuclear Steam Supply System**

The reactor, the reactor coolant pumps, steam generators, and associated piping (and in a pressurized water reactor, the pressurizer) in a nuclear power plant that are used to generate the steam needed to drive the turbine generator unit.

### **Nucleon**

Common name for a constituent particle of the atomic nucleus. At present, applied to protons and neutrons, but may include any other particles found to exist in the nucleus.

### **Nucleus; nuclei (plural)**

The small, central, positively charged region of an atom that carries essentially all of the mass. Except for the nucleus of ordinary (light) hydrogen, which has a single proton, all atomic nuclei contain both protons and neutrons. The number of protons determines the total positive charge, or atomic number. This is the same for all the atomic nuclei of a given chemical element. The total number of neutrons and protons is called the mass number.

### **Nuclide**

A general term referring to all known isotopes, both stable (279) and unstable (about 5,000), of the chemical elements.

### **Operable**

A system, subsystem, train, component, or device shall be operable or have operability when it is capable of performing its specified function(s), and when all necessary attendant instrumentation, controls, electrical power, cooling or seal water, lubrication, or other auxiliary equipment that are required for the system, subsystem, train, component, or device to perform its function(s) are also capable of performing their related support function(s).

### **Operating Basis Earthquake**

An earthquake that could be expected to affect the plant site, but for which the plant power production equipment is designed to remain functional without undue risk to public health and safety.

### **Operational Mode**

An operational mode shall correspond to any one inclusive combination of core reactivity condition, power level, and average reactor coolant temperature. The specific definition of an operation mode can be found in a table in a plant's Technical Specifications.

### **Parent**

A radionuclide that upon radioactive decay or disintegration yields a specific nuclide (the daughter).

### **Parts per Million (ppm)**

Parts (molecules) of a substance contained in a million parts of another substance (water, for example).

### **Pellet, Fuel**

As used in PWRs and BWRs, a fuel pellet is a small cylinder approximately 3/8" in diameter and 5/8" in length, consisting of uranium fuel in a ceramic form - uranium dioxide, UO<sub>2</sub>. Typical fuel pellet enrichments range from natural uranium to 5.2% uranium.

### **Periodic Table**

An arrangement of chemical elements in order of increasing atomic number. Elements of similar properties are placed one under the other, yielding groups or families of elements. Within each group, there is a variation of chemical and physical properties, but in general, there is a similarity of chemical behavior.

### **Personnel Monitoring**

The use of survey meters to determine the amount of radioactive contamination on an individual, or the use of dosimetry to determine an individual's radiation dose.

### **Photodosimetry**

The determination of the cumulative dose of ionizing radiation by use of photographic film.

### **Photon**

A quantum (or packet) of energy emitted in the form of electromagnetic radiation. Gamma rays and x-rays are examples of photons.

### **Pico-**

A prefix that divides a basic unit by one trillion.

### **Picocurie**

One trillionth of a curie.

### **Pig**

A container (usually lead) used to ship or store radioactive materials. The thick walls protect the person handling

the container from radiation. Large containers are commonly called casks.

### **Pile**

A nuclear reactor. It is called a pile because the earliest reactors were "piles" of graphite and uranium blocks.

### **Planned Special Exposure**

An infrequent exposure to radiation, separate from, and in addition to, the annual dose limits.

### **Plutonium**

A heavy, radioactive, manmade metallic element with atomic number 94. Its most important isotope is fissile plutonium-239, which is produced by neutron irradiation of uranium-238.

### **Pocket Dosimeter**

A small ionization detection instrument that indicates radiation exposure directly. An auxiliary charging device is usually necessary.

### **Poison (neutron poison)**

In reactor physics, a material, other than fissionable material, in the vicinity of the reactor core that will absorb neutrons. The addition of poisons, such as control rods or boron, into the reactor is said to be an addition of negative reactivity.

### **Pool Reactor**

A reactor in which the fuel elements are suspended in a pool of water that serves as the reflector, moderator, and coolant. Popularly called a "swimming pool reactor," it is used for research and training, not for electrical generation.

### **Positron**

Particle equal in mass, but opposite in charge, to the electron (a positive electron).

### **Power Coefficient of Reactivity**

The change in reactivity per percent change in power. The power coefficient is the summation of the moderator temperature coefficient of reactivity, the fuel temperature coefficient of reactivity, and the void coefficient of reactivity.

### **Power Defect**

The total amount of reactivity added due to a given change in power. It can also be expressed as the integrated power coefficient over the range of the power change.

### **Power Reactor**

A reactor designed to produce heat for electric generation, as distinguished from reactors used for research, for producing radiation or fissionable materials, or for reactor component testing.

### **Pressure Vessel**

A strong-walled container housing the core of most types of power reactors. It usually also contains the moderator, neutron reflector, thermal shield, and control rods.

### **Pressurized Water Reactor (PWR)**

A power reactor in which heat is transferred from the core to a heat exchanger by high temperature water kept under high pressure in the primary system. Steam is generated in the secondary system. Many reactors producing electric power in the United States are pressurized water reactors.

### **Pressurizer (PZR)**

A tank or vessel that acts as a head tank (or surge volume) to control the pressure in a pressurized water reactor.

### **Primary System**

A term that may be used for referring to the reactor coolant system.

### **Proportional Counter**

An instrument in which an electronic detection system receives pulses that are proportional to the number of ions formed in a gas-filled tube by ionizing radiation.

### **Proton**

An elementary nuclear particle with a positive electric charge located in the nucleus of an atom.

### **Quadrant Power Tilt Ratio (QPTR)**

The ratio of the maximum upper excore detector calibrated output to the average of the upper excore detector calibrated outputs, or the ratio of the maximum lower excore detector calibrated output to the average of the lower excore detector calibrated outputs, whichever is greater.

### **Quality Factor**

The factor by which the absorbed dose (rad) is to be multiplied to obtain a quantity that expresses, on a common scale for all ionizing radiation, the biological damage (rem) to exposed persons. It is used because some types of radiation, such as alpha particles, are more biologically damaging than other types.

### **Quantum Theory**

The concept that energy is radiated intermittently in units of definite magnitude called quanta, and absorbed in a like manner.

### **Rad**

Acronym for radiation absorbed dose, the basic unit of absorbed dose of radiation. A dose of one rad means the absorption of 100 ergs (a small but measurable amount of energy) per gram of absorbing material. The type of radiation (alpha, beta, gamma, etc) is immaterial regarding the energy absorbed.

### **Radiac**

An acronym derived from "radioactivity detection, indication, and computation." It is a generic term applied to radiological instruments or equipment.

### **Radiation Area**

Any area with radiation levels greater than 5 mrem in one hour at 30 cm from the source or from any surface through which the radiation penetrates.

### **Radiation Detection Instrument**

A device that detects and records the characteristics of ionizing radiation.

### **Radiation Shielding**

Reduction of radiation by interposing a shield of absorbing material between any radioactive source and a person, work area, or radiation-sensitive device.

### **Radiation Sickness (syndrome)**

The complex of symptoms characterizing the disease known as radiation injury, resulting from excessive exposure of the whole body (or large part of the whole body) to ionizing radiation. The earliest of these symptoms are nausea, fatigue, vomiting, and diarrhea, which may be followed by loss of hair (epilation), hemorrhage, inflammation of the mouth and throat, and general loss of energy. In severe cases, where the radiation exposure has been relatively large, death may occur within two to four weeks. Those who survive 6 weeks after the receipt of a single large dose of radiation may generally be expected to recover.

### **Radiation Source**

Usually a manmade sealed source of radiation used in teletherapy, radiography, as a power source for batteries, or in various types of industrial gauges. Machines such as accelerators and radioisotope generators and natural radionuclides may be considered sources.

### **Radiation Standards**

Exposure standards, permissible concentrations, rules for safe handling, regulations for transportation, regulations for industrial control of radiation, and control of radioactive material by legislative means.

### **Radiation Warning Symbol**

An officially prescribed symbol (a magenta or black trefoil) on a yellow background that must be displayed where certain quantities of radioactive materials are present or where certain doses of radiation could be received.

### **Radiation, Nuclear**

Particles (alpha, beta, neutrons) or photons (gamma) emitted from the nucleus of an unstable radioactive atom as a result of radioactive decay.

### **Radiation, Nuclear**

Particles (alpha, beta, neutrons) or photons (gamma) emitted from the nucleus of an unstable radioactive atom as a result of radioactive decay.

### **Radiation, Nuclear**

Particles (alpha, beta, neutrons) or photons (gamma) emitted from the nucleus of an unstable radioactive atom as a result of radioactive decay.

### **Radioactive**

Exhibiting radioactivity or pertaining to radioactivity.

### **Radioactive Contamination**

Deposition of radioactive material in any place where it may harm persons or equipment.

### **Radioactive Isotope**

A radioisotope.

### **Radioactive Series**

A succession of nuclides, each of which transforms by radioactive disintegration into the next until a stable nuclide results. The first member is called the parent, the intermediate members are called daughters, and the final stable member is called the end product.

### **Radioactivity**

The spontaneous emission of radiation, generally alpha or beta particles, often accompanied by gamma rays, from the nucleus of an unstable isotope.

### **Radiography**

The making of a shadow image on photographic film by the action of ionizing radiation.

### **Radioisotope**

An unstable isotope of an element that decays or disintegrates spontaneously, emitting radiation. Approximately 5,000 natural and artificial radioisotopes have been identified.

### **Radiological Survey**

The evaluation of the radiation hazards accompanying the production, use, or existence of radioactive materials under a specific set of conditions. Such evaluation customarily includes a physical survey of the disposition of materials and equipment, measurements or estimates of the levels of radiation that may be involved, and a sufficient knowledge of processes affecting these materials to predict hazards resulting from expected or possible changes in materials or equipment.

### **Radiology**

That branch of medicine dealing with the diagnostics and therapeutic applications of radiant energy, including x-rays and radioisotopes.

### **Radionuclide**

A radioisotope.

### **Radiosensitivity**

The relative susceptibility of cells, tissues, organs, organisms, or other substances to the injurious action of radiation.

### **Radium (Ra)**

A radioactive metallic element with atomic number 88. As found in nature, the most common isotope has a mass number of 226. It occurs in minute quantities associated with uranium in pitchblend, carnotite, and other minerals.

### **Radon (Rn)**

A radioactive element that is one of the heaviest gases known. Its atomic number is 86. It is a daughter of radium.

### **Reaction**

Any process involving a chemical or nuclear change.



**Reactivity**

A term expressing the departure of a reactor system from criticality. A positive reactivity addition indicates a move toward supercriticality (power increase). A negative reactivity addition indicates a move toward subcriticality (power decrease).

**Reactor Coolant System (RCS)**

The cooling system used to remove energy from the reactor core and transfer that energy either directly or indirectly to the steam turbine.

**Reactor, Nuclear**

A device in which nuclear fission may be sustained and controlled in a self-supporting nuclear reaction. The varieties are many, but all incorporate certain features, including fissionable material or fuel, a moderating material (unless the reactor is operated on fast neutrons), a reflector to conserve escaping neutrons, provisions for removal of heat, measuring and controlling instruments, and protective devices.

**Recycling**

The reuse of fissionable material after it has been recovered by chemical processing from spent or depleted reactor fuel, re-enriched, and then refabricated into new fuel elements.

**Reflector**

A layer of material immediately surrounding a reactor core that scatters back (or reflects) into the core many neutrons that would otherwise escape. The returned neutrons can then cause more fissions and improve the neutron economy of the reactor. Common reflector materials are graphite, beryllium, water, and natural uranium.

**Rem**

The special unit of dose equivalent. The dose equivalent equals the absorbed dose multiplied by the quality factor.

**Restricted Area**

Any area to which access is controlled for the protection of individuals from exposure to radiation and radioactive materials.

**Roentgen**

A unit of exposure to ionizing radiation. It is the amount of gamma or x-rays required to produce ions resulting in a charge of 0.000258 coulombs/kilogram of air under standard conditions. Named after Wilhelm Roentgen, German scientist who discovered x-rays in 1895.

**Safe Shutdown Earthquake**

A design-basis earthquake.

**Safeguards**

The protection of special nuclear material (SNM) to prevent theft, loss, or sabotage.

**Safety Injection**

The rapid insertion of a chemically soluble neutron poison (i.e., boric acid) into the reactor coolant system to ensure reactor shutdown.

**Safety Limit**

A limit placed upon important process variables which are found to be necessary to reasonably protect the integrity of the physical barriers which guard against the uncontrolled release of radioactivity.

**Safety Related**

The managerial controls, administrative documents, operating procedures, systems, structures, and components that have been designed to mitigate the consequences of postulated accidents that could cause undue risk to public health and safety.

**Scattered Radiation**

Radiation that, during its passage through a substance, has been changed in direction. It may also have been modified by a decrease in energy. It is one form of secondary radiation.

**Scram**

A term that is used by boiling water reactors for the rapid insertion of all control rods to shut down the reactor/fission process

**Sievert**

The SI, or international, unit of dose equivalent. The dose equivalent equals the absorbed dose (grays) multiplied by the quality factor (Q).

**Somatic Effects of Radiation**

Effects of radiation limited to the exposed individual, as distinguished from genetic effects, which may also affect subsequent unexposed generations.

**Special Nuclear Material**

Includes plutonium, uranium-233, or uranium enriched in the isotopes uranium-233 or uranium-235.

**Spent (depleted) Fuel**

Nuclear reactor fuel that has been used to the extent that it can no longer effectively sustain a chain reaction.

**Spent Fuel Pool**

An underwater storage and cooling facility for fuel elements that have been removed from a reactor.

**Stability**

The ability of the waste to resist weathering, rusting, erosion, dissolving, etc.

**Stable Isotope**

An isotope that does not undergo radioactive decay.

**Startup**

An increase in the rate of fission (and heat production) in a reactor (usually by the removal of control rods from the core).

**Stay Time**

The period during which personnel may remain in a restricted area before accumulating some permissible dose.

**Steam Generator (SG; S/G)**

The heat exchanger used in some reactor designs to transfer heat from the primary (reactor coolant) system to the secondary (steam) system. This design permits heat exchange with little or no contamination of the secondary system equipment.

**Subcritical Mass**

An amount of fissionable material insufficient in quantity or of improper geometry to sustain a fission chain reaction.

**Subcriticality**

The condition of a nuclear reactor system when the rate of production of fission neutrons is lower than the rate of production in the previous generation due to increased neutron leakage and poisons.

**Supercritical Reactor**

A reactor in which the power level is increasing.

**Supercriticality**

The condition for increasing the level of operation of a reactor. The rate of fission neutron production exceeds all neutron losses, and the overall neutron population increases.

**Superheating**

The heating of a vapor, particularly steam, to a temperature much higher than the boiling point at the existing pressure. This is done in some power plants to improve efficiency and to reduce water damage to the turbine.

**Survey**

A study to:

1. Find the radiation or contamination level of specific objects or locations within an area of interest
2. Locate regions of higher-than-average intensity (hot spots)

**Survey Meter**

Any portable radiation detection instrument especially adapted for inspecting an area to establish the existence and amount of radioactive material present.

**Tenth Thickness**

The thickness of a given material that will decrease the amount (or dose) of radiation to one-tenth of the amount incident upon it. Two tenth thicknesses will reduce the dose by a factor of 10 x 10 (or 100) and so on.

**Terrestrial Radiation**

The portion of the natural radiation (background) that is emitted by naturally occurring radioactive materials in the earth.

**Thermal Breeder Reactor**

A breeder reactor in which the fission chain reaction is sustained by thermal neutrons.

**Thermal Power**

The total core heat transfer rate to the reactor coolant.

**Thermal Reactor**

A reactor in which the fission chain reaction is sustained primarily by thermal neutrons. Most current reactors are thermal reactors.

**Thermal Shield**

A layer, or layers, of high-density material located within a reactor pressure vessel or between the vessel and the biological shield to reduce radiation heating in the vessel and the biological shield.

**Thermalization**

The process undergone by high-energy (fast) neutrons as they lose energy by collision.

**Thermoluminescent Detector**

A device used to measure radiation by measuring the amount of visible light emitted from a crystal in the detector when exposed to radiation.

**Thermonuclear**

An adjective referring to the process in which very high temperatures are used to bring about the fusion of light nuclei, such as those of the hydrogen isotopes deuterium and tritium, with the accompanying liberation of energy.

**Transient**

A change in the reactor coolant system temperature and/or pressure due to a change in power output of the reactor. Transients can be caused by adding or removing neutron poisons, by increasing or decreasing electrical load on the turbine generator, or by accident conditions.

**Trip, Reactor**

A term that is used by pressurized water reactors for a reactor scram.

**Tritium**

A radioactive isotope of hydrogen (one proton, two neutrons). Because it is chemically identical to natural hydrogen, tritium can easily be taken into the body by any ingestion path. It decays by beta emission. It has a radioactive half-life of about 12.5 years.

**Turbine**

A rotary engine made with a series of curved vanes on a rotating shaft, usually turned by water or steam. Turbines are considered the most economical means to turn large electrical generators.

**Turbine Generator (TG)**

A steam (or water) turbine directly coupled to an electrical generator. The two devices are often referred to as one unit.

**Ultraviolet**

Electromagnetic radiation of a wavelength between the shortest visible violet and low energy x-rays.

**Unrestricted Area**

The area outside the owner-controlled portion of a nuclear facility (usually the site boundary). An area in which a person could not be exposed to radiation levels in excess of 2 mrem in any one hour from external sources.

**Unstable Isotope**

A radioisotope.

**Uranium (U)**

A radioactive element with the atomic number 92 and, as found in natural ores, an atomic weight of approximately 238. The two principal natural isotopes are uranium-235 (0.7% of natural uranium), which is fissile, and uranium-238 (99.3% of natural uranium), which is fissionable by fast neutrons and is fertile.

**Vapor**

The gaseous form of substances that are normally in liquid or solid form.

**Very High Radiation Area**

An area in which radiation levels exceed 500 rad in one hour at 1 meter from the source or from any surface that the radiation penetrates.

**Void**

An area of lower density in a moderating system (such as steam bubbles in water) that allows more neutron leakage than does the more dense material around it.

**Void Coefficient of Reactivity**

The change in reactivity per percent change in void content due to an increase in the neutron leakage as the density of the moderator decreases with an increasing void content.

**Waste, Radioactive**

Solid, liquid, and gaseous materials from nuclear operations that are radioactive or become radioactive and for which there is no further use. Wastes are generally classified as high level (having radioactivity concentrations of hundreds of thousands of curies per gallon or foot), low level (in the range of 1 microcurie per gallon or foot), or intermediate level (between these extremes).

**Whole-Body Counter**

A device used to identify and measure the radioactive material in the body (body burden) of human beings and animals. It uses heavy shielding to keep out background radiation and ultrasensitive radiation detectors and electronic counting equipment.

**Whole-Body Exposure**

An exposure of the body to radiation, in which the entire body, rather than an isolated part, is irradiated. Where a radioisotope is uniformly distributed throughout the body tissues, rather than being concentrated in certain parts, the irradiation can be considered as whole-body exposure.

**Wipe Sample**

A sample made for the purpose of determining the presence of removable radioactive contamination on a surface. It is done by wiping, with slight pressure, a piece of soft filter paper over a representative type of surface area. It is also known as a "swipe sample," or "smear."

**X-rays**

Penetrating electromagnetic radiation (photon) having a wavelength that is much shorter than that of visible light. These rays are usually produced when an excited electron falls to a lower energy level around the nucleus. In nuclear reactions, it is customary to refer to photons originating in the nucleus as gamma rays, and to those originating in the electron cloud of the atoms as x-rays. These rays are sometimes called roentgen rays after their discoverer, W. K. Roentgen.

**Yellowcake**

A solid uranium-oxygen compound (U<sub>3</sub>O<sub>8</sub>) that takes its name from its color and texture. It is a product of the uranium milling process and is the feed material used for fuel enrichment and pellet fabrication.

For additional information, consult:

**Go To Top**

- [Title 10 - Energy, Code of Federal Regulations, Chapter I - Nuclear Regulatory Commission, Part 20 - Standards for Protection against Radiation \(10 CFR 20\)](#)
- [Title 40 - Protection of the Environment, Code of Federal Regulations, Chapter 1 - Environmental Protection Agency, Part 190 - Environmental Radiation Protection Standards for Nuclear Power Operations \(40 CFR 190\)](#)
- [Backgrounder on the Three Mile Island Accident: NRC Website, Electronic Reading Room, Document Collections, Fact Sheets, August 2009.\)](#)