

NUREG/CR-5406
EGG-2569
Vol. 2

BWR Reactor Water Cleanup System Flexible Wedge Gate Isolation Valve Qualification and High Energy Flow Interruption Test

Data Report

Prepared by K.G. DeWall, R. Steele, Jr.

Idaho National Engineering Laboratory

EG&G Idaho, Inc.

**Prepared for
U.S. Nuclear Regulatory Commission**

AVAILABILITY NOTICE

Availability of Reference Materials Cited in NRC Publications

Most documents cited in NRC publications will be available from one of the following sources:

1. The NRC Public Document Room, 2120 L Street, NW, Lower Level, Washington, DC 20555
2. The Superintendent of Documents, U.S. Government Printing Office, P.O. Box 37082, Washington, DC 20013-7082
3. The National Technical Information Service, Springfield, VA 22161

Although the listing that follows represents the majority of documents cited in NRC publications, it is not intended to be exhaustive.

Referenced documents available for inspection and copying for a fee from the NRC Public Document Room include NRC correspondence and internal NRC memoranda; NRC Office of Inspection and Enforcement bulletins, circulars, information notices, inspection and investigation notices; Licensee Event Reports; vendor reports and correspondence; Commission papers; and applicant and licensee documents and correspondence.

The following documents in the NUREG series are available for purchase from the GPO Sales Program: formal NRC staff and contractor reports, NRC-sponsored conference proceedings, and NRC booklets and brochures. Also available are Regulatory Guides, NRC regulations in the *Code of Federal Regulations*, and *Nuclear Regulatory Commission Issuances*.

Documents available from the National Technical Information Service include NUREG series reports and technical reports prepared by other federal agencies and reports prepared by the Atomic Energy Commission, forerunner agency to the Nuclear Regulatory Commission.

Documents available from public and special technical libraries include all open literature items, such as books, journal and periodical articles, and transactions. *Federal Register* notices, federal and state legislation, and congressional reports can usually be obtained from these libraries.

Documents such as theses, dissertations, foreign reports and translations, and non-NRC conference proceedings are available for purchase from the organization sponsoring the publication cited.

Single copies of NRC draft reports are available free, to the extent of supply, upon written request to the Office of Information Resources Management, Distribution Section, U.S. Nuclear Regulatory Commission, Washington, DC 20555.

Copies of industry codes and standards used in a substantive manner in the NRC regulatory process are maintained at the NRC Library, 7920 Norfolk Avenue, Bethesda, Maryland, and are available there for reference use by the public. Codes and standards are usually copyrighted and may be purchased from the originating organization or, if they are American National Standards, from the American National Standards Institute, 1430 Broadway, New York, NY 10018.

DISCLAIMER NOTICE

This report was prepared as an account of work sponsored by an agency of the United States Government. Neither the United States Government nor any agency thereof, or any of their employees, makes any warranty, expressed or implied, or assumes any legal liability of responsibility for any third party's use, or the results of such use, of any information, apparatus, product or process disclosed in this report, or represents that its use by such third party would not infringe privately owned rights.

NUREG/CR-5406
EGG-2569
Vol. 2
R1

BWR Reactor Water Cleanup System Flexible Wedge Gate Isolation Valve Qualification and High Energy Flow Interruption Test

Data Report

Manuscript Completed: September 1989
Date Published: October 1989

Prepared by
K.G. DeWall, R. Steele, Jr.

Idaho National Engineering Laboratory
Managed by the U.S. Department of Energy

EG&G Idaho, Inc.
P. O. Box 1625
Idaho Falls, ID 83415

Prepared for
Division of Engineering
Division of Safety Issue Resolution
Office of Nuclear Regulatory Research
U.S. Nuclear Regulatory Commission
Washington, DC 20555
NRC FIN A6857, B5529

FOREWORD

The information contained in Volume II is the actual measured data from the gate valve test program described in Volume I. They are provided here for those readers who wish to look at the data and form their own opinion on the performance of the test valves. For those readers who wish to do their own analysis, the electronic data is available from our DOE Office of Technology Transfer. Requests for the data can be made by calling (208) 526-8318.

CONTENTS

FOREWORD	iii
Figure 1. Simplified GI-87 test loop showing configuration, lengths, and pipe sizes	2
Figure 2. Venturi flow meter calibration curve for converting the ΔP differential pressure measurement to gallons per minute	3
Table 1. Valve diagnostic equipment used for subcooled blowdown tests	4
Table 2. Test parameters measured during blowdown tests	5
Table 3. Test step matrix for qualification and blowdown tests	6
Table 4. Test steps and system pressure and temperature for each test performed	8
Test Data	15

**BWR REACTOR WATER CLEANUP SYSTEM
FLEXIBLE WEDGE GATE ISOLATION VALVE QUALIFICATION AND
HIGH ENERGY FLOW INTERRUPTION TEST
VOLUME II
DATA REPORT**

Volume II presents the measured test data from the gate valve test program described in Volume I. Figure 1 shows the test loop in schematic form and identifies the instrument location and numbers. Figure 2 converts the differential pressure measurement to gallons per minute. Table 1 outlines the test sequence performed on each valve and correlates the data as it is presented here. The header on each plot defines the valve A or B, the test series number, and the test step number. Table 2 lists the test parameters measured during blowdown tests, Table 3 lists the test step matrix for qualification and blowdown tests, and Table 4 lists the test steps and system pressure and temperature for each of the tests performed.

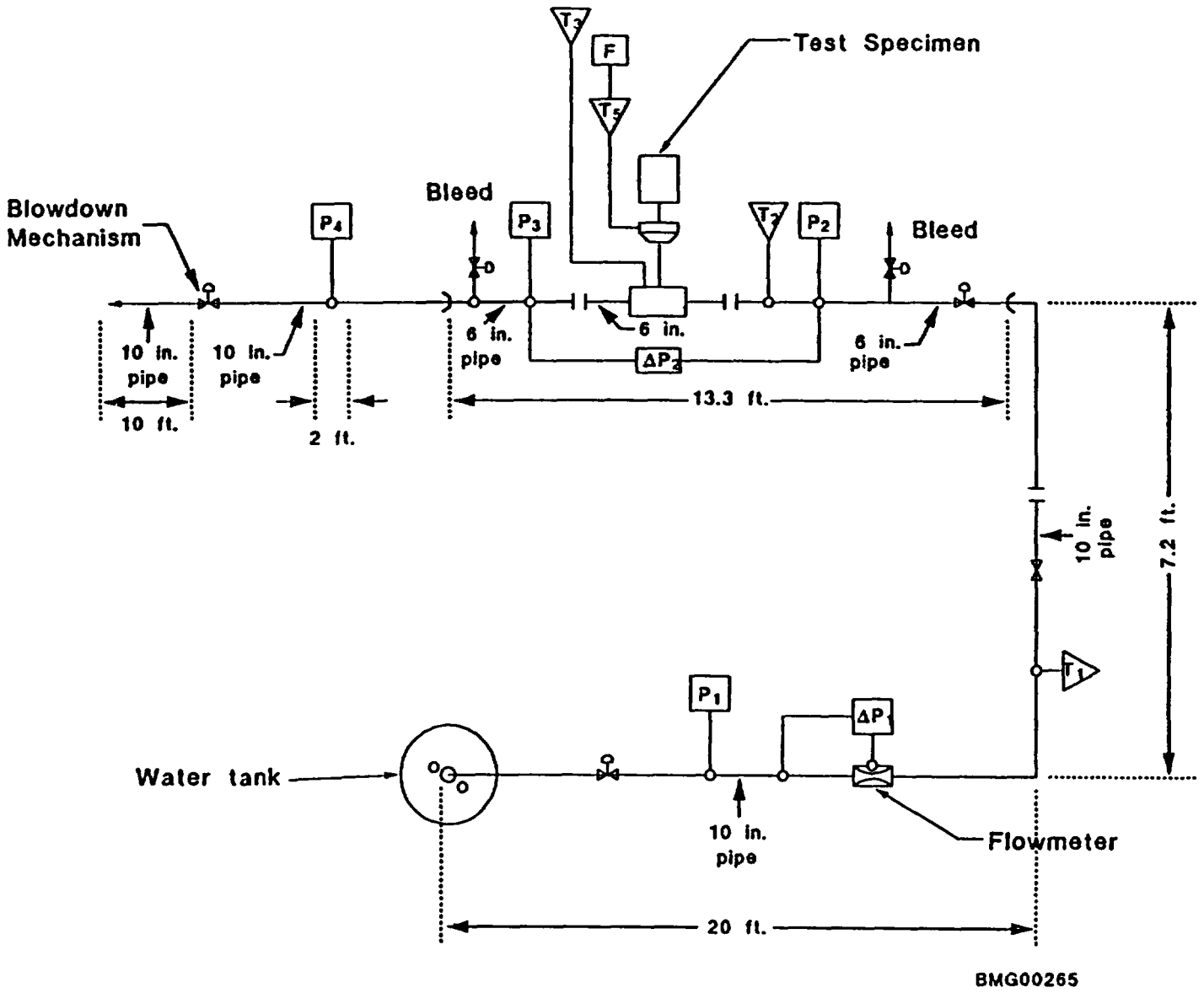
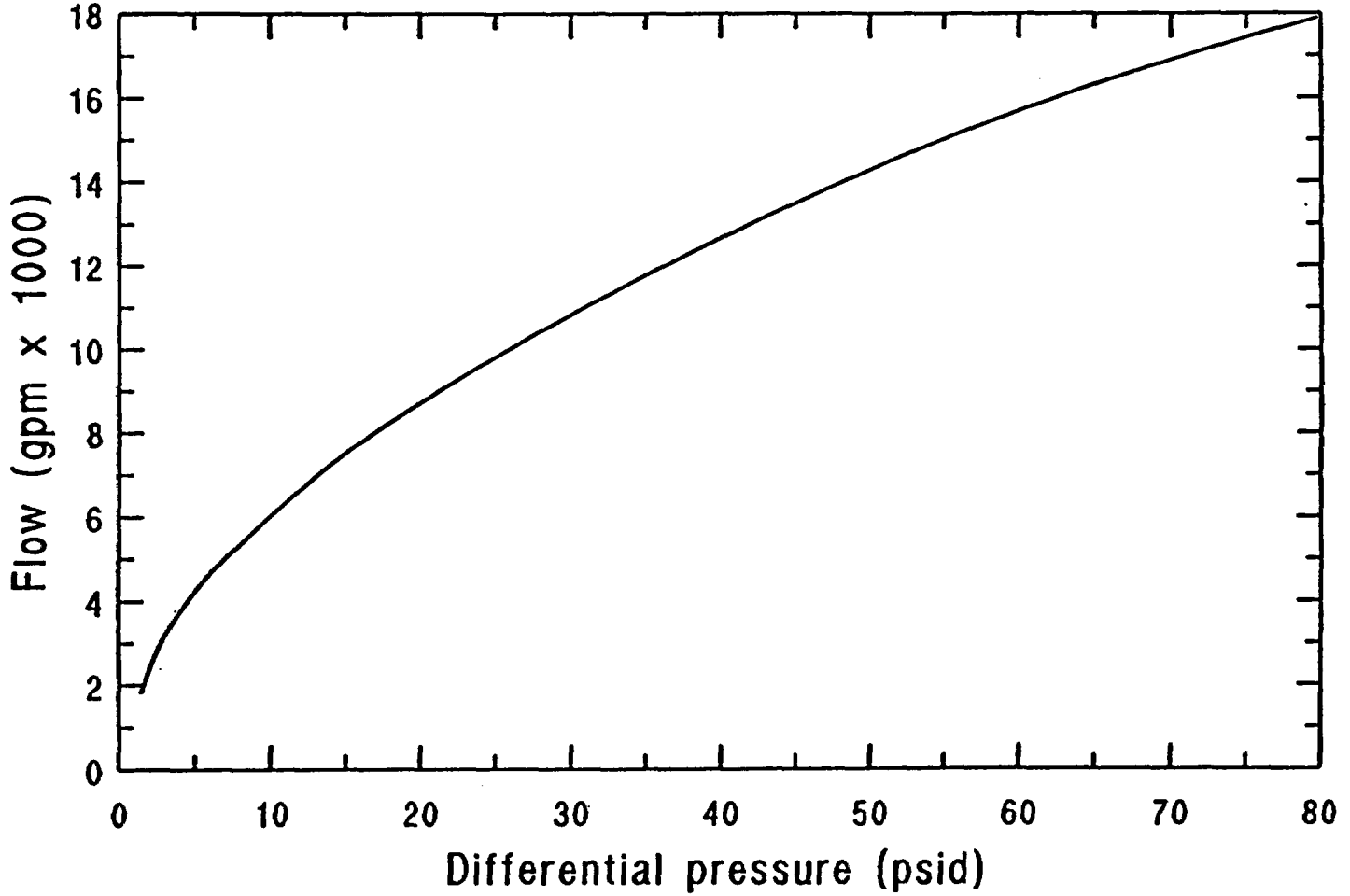

Figure 1. Simplified GI-87 test loop showing configuration, lengths, and pipe sizes.

Venturi Flow Meter



MGH02161

Figure 2. Venturi flow meter calibration curve for converting the ΔP differential pressure measurement to gallons per minute.

Table 1. Valve diagnostic equipment used for subcooled blowdown tests

<u>Valve</u>	<u>Test Series</u>	<u>Description</u>	<u>Diagnostic Equipment*</u>
A	1	Qualification test	MCSA
A	3	Blowdown, 1000 psig, 480°F	MCSA
A	2	Blowdown, 1000 psig, 530°F	None
A	4	Blowdown, 1000 psig, 400°F	V-MODS
A	6	Blowdown, 1400 psig, 530°F	V-MODS
A	5	Blowdown, 1400 psig, 580°F	MOVATS
A	7	Blowdown, 1400 psig, 450°F	MOVATS
A	9	Blowdown, 600 psig, 430°F	None
A	8	Blowdown, 600 psig, 480°F	None
A	10	Blowdown, 600 psig, 350°F	MAC, VOTES
A	11	Blowdown, 1000 psig, 530°F	MCSA
B	1	Qualification test	MCSA
B	2	Blowdown, 1000 psig, 530°F	MCSA, MOVATS
B	3	Blowdown, 1400 psig, 580°F	V-MODS
B	4	Blowdown, 600 psig, 480°F	MAC
B	5	Blowdown, 1000 psig, 530°F	V-MODS

- a. MAC Limitorque Motor Actuator Characterizer
MCSA ORNL Motor Current Signature Analysis
MOVATS MOVATS, Inc. (MOV Analysis and Test System)
V-MODS WYLE Laboratories Valve Motor Operator Diagnostic System
VOTES Liberty Technology Valve Operator Test & Evaluation System

Table 2. Test parameters measured during blowdown tests

<u>Transducer</u>	<u>Measurement</u>	<u>FM Tape</u>	<u>Oscillograph</u>	<u>Data Logger</u>	<u>X-Y Plotter</u>
T1	System water temperature			X	
T2	Test valve inlet water temperature			X	
T3	Test valve body temperature			X	
T4	Heating section water temperature			X	
T5	Load cell temperature			X	
P1	System water pressure	X	X	X	X
P2	Test valve inlet water pressure	X	X	X	
P3	Test valve outlet water pressure	X	X	X	
P4	Discharge section water pressure	X	X	X	
Δ P1	Test valve differential pressure	X	X	X	
Δ P2	Venturi differential pressure	X	X	X	
Δ P3	Pump differential pressure	X		X	
I1	Actuator current	X	X		
I2	Actuator current	X			
I3	Actuator current	X			
E1	Actuator voltage	X	X		
E2	Actuator voltage	X			
ST	Valve stroke-LVDT	X	X		X
LS1	Open limit switch	X	X		
LS2	Close limit switch ^a				
TS	Close torque switch	X	X		
F	Valve stem force	X	X	X	
A1	Actuator acceleration Y	X	X		
A2	Actuator acceleration X	X			
A3	Actuator acceleration Z	X			
A4	Valve body acceleration Y	X	X		
A5	Valve body acceleration X	X			
A6	Valve body acceleration Z	X			

a. Control room light indicator only.

Table 3. Test step matrix for qualification and blowdown tests

<u>Step Number</u>	<u>Valve Cycle</u>	<u>Description</u>
Qualification tests (Test 1, Valves A and B)		
1	O → C	Close valve at 2220 psig, cold
2		Seat leakage test
3	C → pt O	ΔP opening at 1700 psig, cold
4		Packing leakage test
5	pt O → C → O	Cycle valve at 0 psig, cold
6	O → C	Close valve at 2220 psig, cold
7	C → O	ΔP opening at 1700 psig, cold
8	O → C → O	Cycle valve at 0 psig, cold
9	O → C → O	Cycle valve at 0 psig, cold
10	O → C → O	Cycle valve at 0 psig, cold
11	O → C	Close valve at 2220 psig, cold
12	C → O	ΔP opening at 1700 psig, cold
13	O → C	Close valve at 2220 psig, cold
14	C → O	ΔP opening at 1700 psig, cold
15	O → C	Close valve at 2220 psig, cold
16	C → O	ΔP opening at 1700 psig, cold
17	O → C → O	Cycle valve at 0 psig, cold
18	O → C	Close valve at 1650 psig, 600°F
19	C → O	ΔP opening at 1650 psig, 600°F
20	O → C	Close valve at 1650 psig, 600°F
21	C → O	ΔP opening at 1650 psig, 600°F
22	O → C	Close valve at 1650 psig, 600°F
23	C → O	ΔP opening at 1650 psig, 600°F
24	O → C	Close valve at 1650 psig, 600°F
25	C → O	ΔP opening at 1650 psig, 600°F
26	O → C	close valve at 1650 psig, 600°F

Table 3. (continued)

<u>Step Number</u>	<u>Valve Cycle</u>	<u>Description</u>
Blowdown tests (Valve A, Tests 2–11, and Valve B, Tests 2–5)		
0	O → C → O	Cycle valve at test pressure and temperature
1	O → C	Close valve at test pressure and temperature
2	C → O	ΔP opening at test pressure and temperature
3	O → C	Close valve at 100 gpm, test pressure and temperature
4	C → O	Open valve at 100 gpm, test pressure and temperature
5	O → C	Blowdown at test pressure and temperature
6	C → pt O	Blowdown at test pressure and temperature
7	pt O → C	Blowdown at test pressure and temperature
8	C → O	Open valve at 0 psig and test temperature
9	O → C → O	Cycle valve at 0 psig and test temperature
Final cold testing (Valve A, Test 11, and Valve B, Test 5)		
10	C → O	ΔP opening at 1000 psig, cold
11	O → C	Close valve at 1000 psig, cold
12		Seat leakage test
13	C → pt O	ΔP opening at 1000 psig, cold
14		Packing leakage test
15	pt O → O	Open valve at 1000 psig, cold
16	O → C	Close valve at 1000 psig, cold
17	C → O	ΔP opening at 1000 psig, cold
18	O → C	Close valve at 0 psig, cold
19	C → O	Open valve at 0 psig, cold
20	O → C	Close valve at 0 psig, cold
21	C → O	Open valve at 0 psig, cold
22	O → C	Close valve at 0 psig, cold
23	C → O	Open valve at 0 psig, cold
O	open	
C	close	
pt	partial valve stroke	

Table 4. Test steps and system pressure and temperature for each test performed

Step Number	Valve Cycle	Test Pressure (psig)	Test Temperature (°F)	Remarks
Valve A, Test 1, Qualification test, 4/20 & 25/88				
1	O → C	2246	58	
2		2246	58	Seat leakage test
3	C → pt O	1706	59	ΔP opening
4		1706	59	Packing leakage test
5	pt O → C → O	20	59	
6	O → C	2248	60	
7	C → O	1699	60	ΔP opening
8	O → C → O	25	60	
9	O → C → O	25	60	
10	O → C → O	24	61	
11	O → C	2258	61	
12	C → O	1726	61	ΔP opening
13	O → C	2258	61	
14	C → O	1701	61	ΔP opening
15	O → C	2254	61	
16	C → O	1723	61	ΔP opening
17	O → C → O	17	62	
18	O → C	1655	590	
19	C → O	1615	574	ΔP opening
20	O → C	1664	591	
21	C → O	1558	569	ΔP opening
22	O → C	1679	586	
23	C → O	1573	560	ΔP opening
24	O → C	1653	583	
25	C → O	1510	563	ΔP opening
26 & 27	O → C → O	1623	583	

O open
C close
pt partial valve stroke

Table 4. (continued)

<u>Step Number</u>	<u>Valve Cycle</u>	<u>Test Pressure (psig)</u>	<u>Test Temperature (°F)</u>	<u>Remarks</u>
Valve A, Test 3, Blowdown test, 4/25/88				
1	O → C	1121	476	
2	C → O	1112	469	ΔP opening
3 & 4	O → C → O	1110	483	Normal flow, 100 gpm
5	O → C	1000	480	Blowdown, end with N2 flow
8 & 9	C → O → C → O	0	480	
Valve A, Test 2, Blowdown test, 4/30/88				
1	O → C	1170	540	
2	C → O	1121	514	ΔP opening
3 & 4	O → C → O	1095	510	Normal flow, 100 gpm
5	O → C	1009	524	Blowdown
6 & 7	C → pt O → C	1041	505	Blowdown 50% open, end with N2
8 & 9	C → O → C → O	15	404	
Valve A, test 4, Blowdown test, 5/3/88				
1	O → C	1029	403	
2	C → O	1020	400	ΔP opening
3 & 4	O → C → O	974	400	Normal flow, 100 gpm
5	O → C	1071	418	Blowdown 50% open
7	pt O → C	1122	414	Blowdown 75% open
8 & 9	C → O → C → O	23	370	
Valve A, Test 6, Blowdown test, 5/6/88				
1	O → C	1430	515	
2	C → O	1402	516	ΔP opening
3 & 4	O → C → O	1408	518	Normal flow, 100 gpm
5	O → C	1408	518	Blowdown, end with N2
8 & 9	C → O → C → O	7	428	

Table 4. (continued)

<u>Step Number</u>	<u>Valve Cycle</u>	<u>Test Pressure (psig)</u>	<u>Test Temperature (°F)</u>	<u>Remarks</u>
Valve A, Test 5, Blowdown test, 5/11/88				
1	O → C	1558	581	
2	C → O	1540	580	ΔP opening
3 & 4	O → C → O	1600	586	Normal flow, 100 gpm
5	O → C	1624	583	Blowdown 83% open
6 & 7	C → pt O → C	1535	560	Blowdown 50% open
8 & 9	C → O → C → O	7	450	
Valve A, Test 7, Blowdown test, 5/13/88				
1	O → C	1330	496	
2	C → O	1356	493	ΔP opening
3 & 4	O → C → O	1331	496	Normal flow, 100 gpm
5	O → C	1431	509	Blowdown
6 & 7	C → pt O → C	1372	494	Blowdown 60% open, end on N2
8 & 9	C → O → C → O	2	440	
Valve A, Test 9, Blowdown test, 5/17/88				
1	O → C	684	443	
2	C → O	612	438	ΔP opening
3 & 4	O → C → O	618	452	Normal flow, 100 gpm
5	O → C	645	451	Blowdown
8 & 9	C → O → C → O	6	435	
Valve A, Test 8, Blowdown test, 5/19/88				
1	O → C	694	486	
2	C → O	674	483	ΔP opening
3 & 4	O → C → O	655	482	Normal flow, 100 gpm
5	O → C	590	488	Blowdown 75% open
6 & 7	C → pt O → C	655	460	Blowdown 75% open
8 & 9	C → O → C → O	5	446	

Table 4. (continued)

<u>Step Number</u>	<u>Valve Cycle</u>	<u>Test Pressure (psig)</u>	<u>Test Temperature (°F)</u>	<u>Remarks</u>
Valve A, Test 10, Blowdown test, 5/24/88				
1	O → C	660	354	
2	C → O	656	352	ΔP opening
3 & 4	O → C → O	617	357	Normal flow, 100 gpm
5	O → C	641	367	Blowdown 75% open
6 & 7	C → pt O → C	650	355	Blowdown 50% open
8 & 9	C → O → C → O	5	351	
Valve A, Tests 11, Blowdown test, 5/27 & 28/88				
1	O → C	980	507	
2	C → O	975	502	ΔP opening
3 & 4	O → C → O	1000	524	Normal flow, 100 gpm
5	O → C	1080	524	Blowdown
6 & 7	C → pt O → C	1080	497	Blowdown 36% open
8	C → O	1020	486	ΔP opening
9	O → C	7	393	
Final Cold Testing				
10	C → O	1080	79	ΔP opening
11	O → C	1080	98	
12		1080	98	Leakage test
13	C → pt O	1091	85	ΔP opening
14	pt O → C	1081	98	
15	C → O	1081	99	ΔP opening
16	O → C	1078	105	
17	C → O	1079	99	ΔP opening
18 & 19	O → C → O	22	104	
20 & 21	O → C → O	24	104	
22 & 23	O → C → O	25	104	

Table 4. (continued)

<u>Step Number</u>	<u>Valve Cycle</u>	<u>Test Pressure (psig)</u>	<u>Test Temperature (°F)</u>	<u>Remarks</u>
Valve B, Test 1, Qualification test, 6/7, 8, & 13/88				
1	O → C	2161	77	
2		2161	77	Seat leakage test
3	C → pt O	1738	77	ΔP opening
4		1738	77	Packing leakage test
5	pt O → C → O	1	75	
6	O → C	2233	75	
7	C → O	1708	75	ΔP opening
8	O → C → O	7	75	
9	O → C → O	8	75	
10	O → C → O	8	75	
11	O → C	2355	75	
12	C → O	1685	75	ΔP opening
13	O → C	2210	75	
14	C → O	1713	75	ΔP opening
15	O → C	2170	75	
16	C → O	1700	75	ΔP opening
17	O → C → O	22	75	
18	O → C	1641	586	
19	C → O	1630	582	ΔP opening
20	O → C	1616	579	
21	C → O	1513	575	ΔP opening
22	O → C	1694	570	
23	C → O	1593	570	ΔP opening
24	O → C	1659	567	
25	C → O	1657	565	ΔP opening
26	O → C → O	1739	573	

Table 4. (continued)

<u>Step Number</u>	<u>Valve Cycle</u>	<u>Test Pressure (psig)</u>	<u>Test Temperature (°F)</u>	<u>Remarks</u>
Valve B, Test 2, Blowdown test, 6/14/88				
1	O → C	1109	518	
2	C → O	1084	516	ΔP opening
3 & 4	O → C → O	1125	524	Normal flow, 100 gpm
5	O → C	987	524	Blowdown
6 & 7	C → pt O → C	1006	508	Blowdown 50% open, end with N2
8 & 9	C → O → C → O	22	428	
Valve B, Test 3, Blowdown test, 6/17/88				
1	O → C	16703	583	
2	C → O	1544	579	ΔP opening
3 & 4	O → C → O	1529	575	Normal flow, 100 gpm
5	O → C	1406	563	Blowdown
6 & 7	C → pt O → C	1492	557	Blowdown 40% open, end with N2
8 & 9	C → O → C → O	23	495	
Valve B, Test 4, Blowdown test, 6/21/88				
1	O → C	734	497	
2	C → O	749	493	ΔP opening
3 & 4	O → C → O	733	491	Normal flow, 100 gpm
5	O → C	631	493	Blowdown
6 & 7	C → pt O → C	634	488	Blowdown 50% open
8 & 9	C → O → C → O	30	276	

Table 4. (continued)

<u>Step Number</u>	<u>Valve Cycle</u>	<u>Test Pressure (psig)</u>	<u>Test Temperature (°F)</u>	<u>Remarks</u>
Valve B, Test 5, Blowdown test, 6/24 & 27/88				
1		956	524	
2		944	521	ΔP opening
3 & 4		933	520	Normal flow, 100 gpm
5		970	517	Blowdown, end on N2
8		52	433	
9		2	431	
Final Cold Testing				
10		1033	82	ΔP opening
11		1030	86	
12		1030	86	Leakage test
13		982	83	ΔP opening
14		984	87	
15		997	85	ΔP opening
16		1016	88	
17		1036	85	ΔP opening
18 & 19		17	84	
20 & 21		18	86	
22 & 23		18	86	

VALVE A, TEST 1, STEP 1

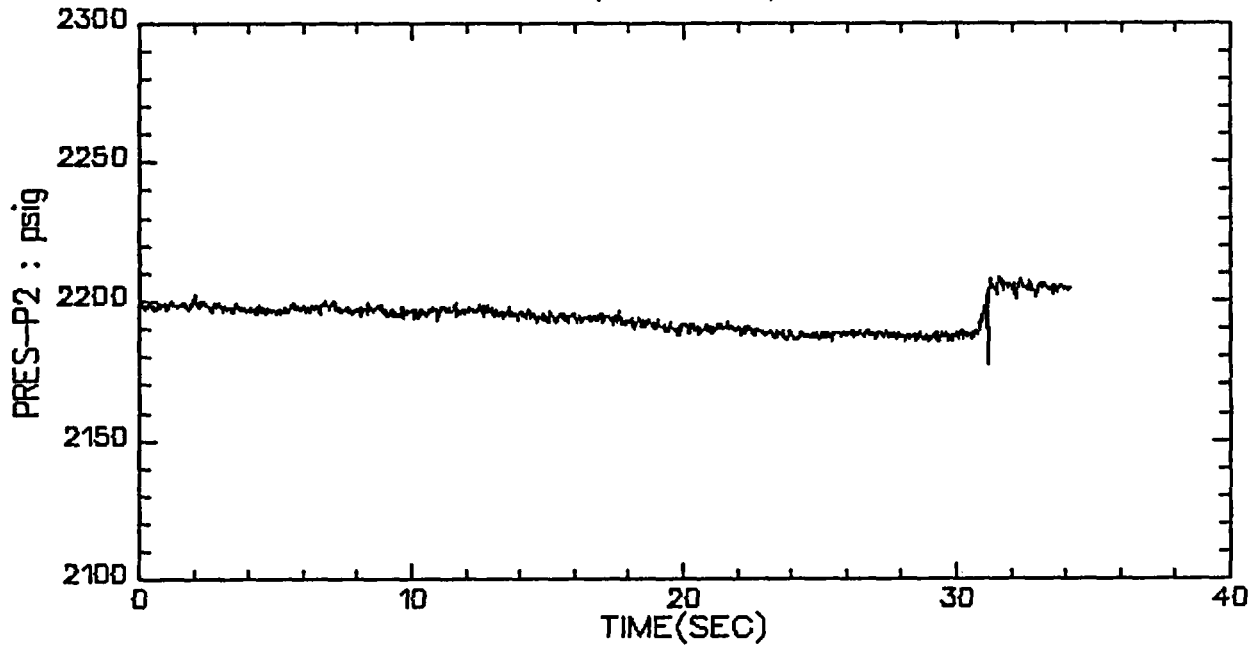

VALVE A, TEST 1, STEP 1

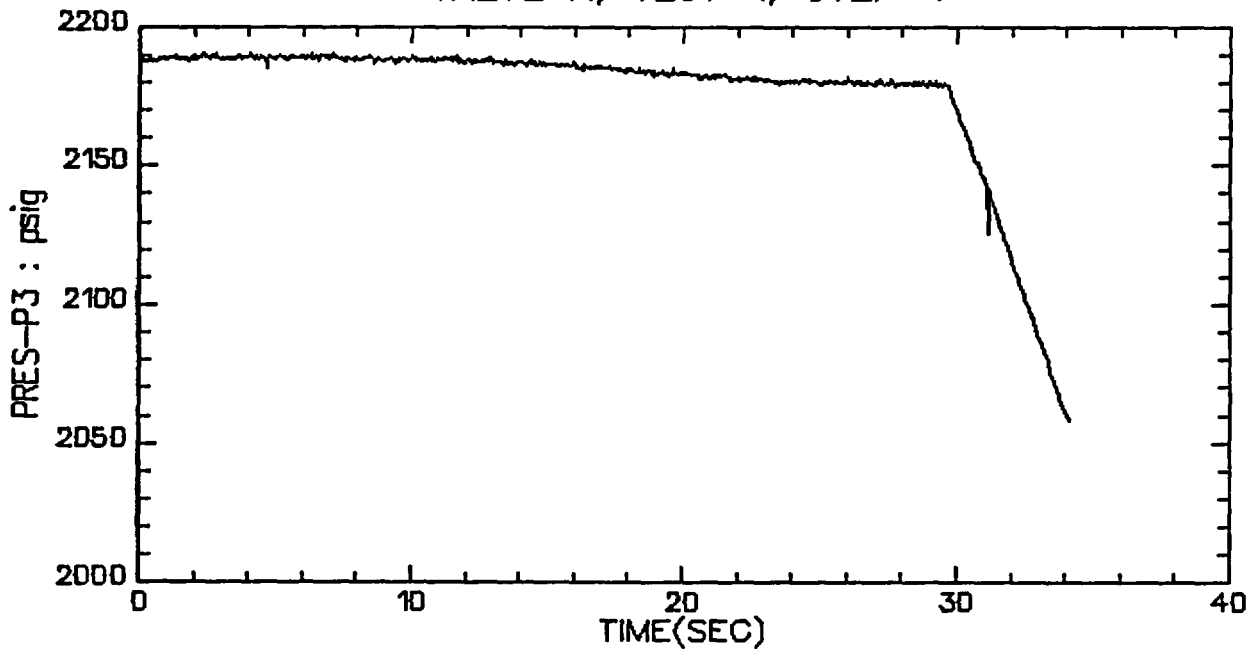

VALVE A, TEST 1, STEP 1

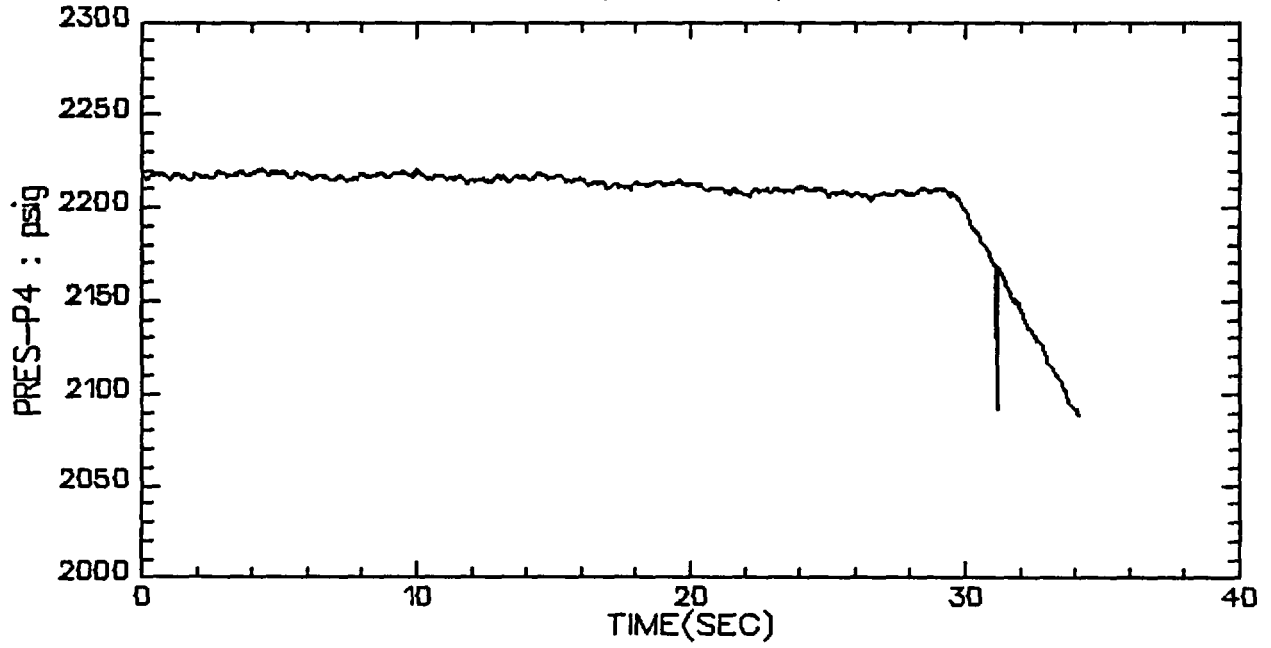

VALVE A, TEST 1, STEP 1

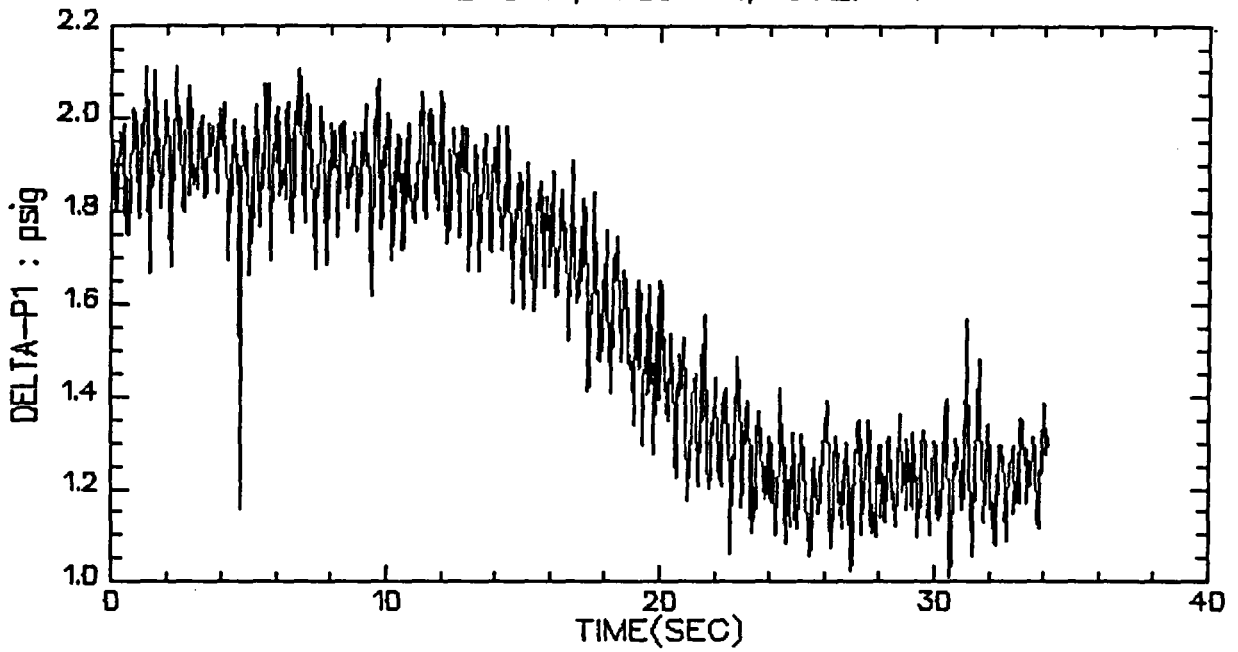

VALVE A, TEST 1, STEP 1

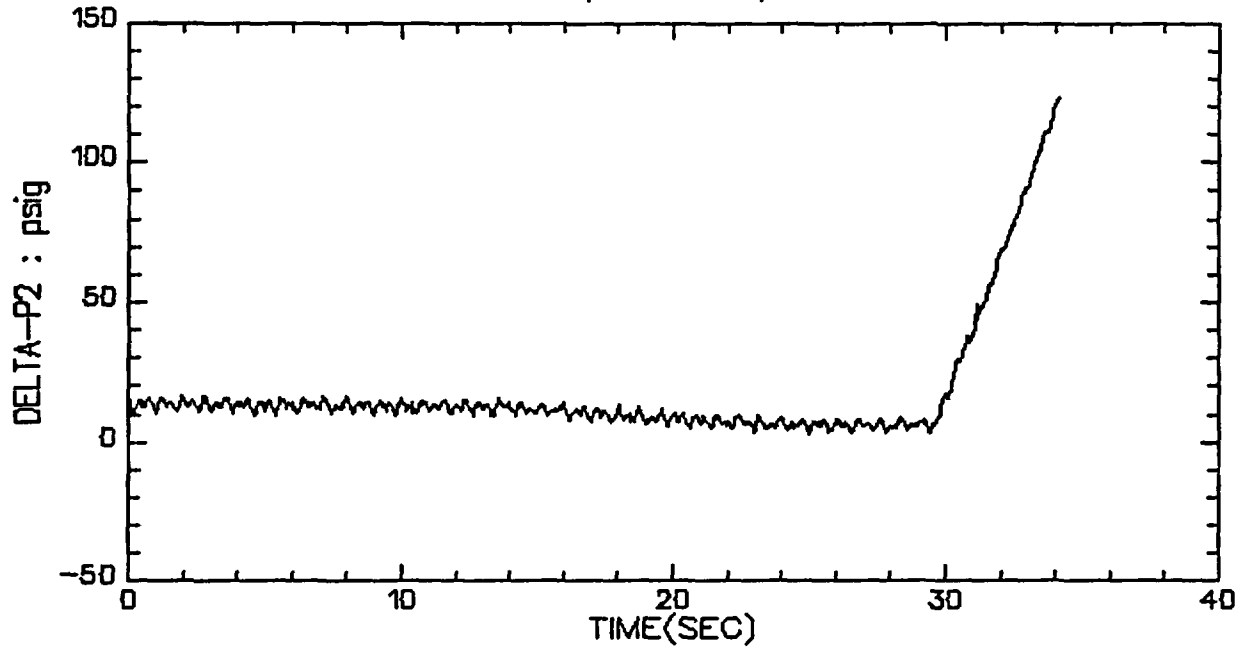

VALVE A, TEST 1, STEP 1

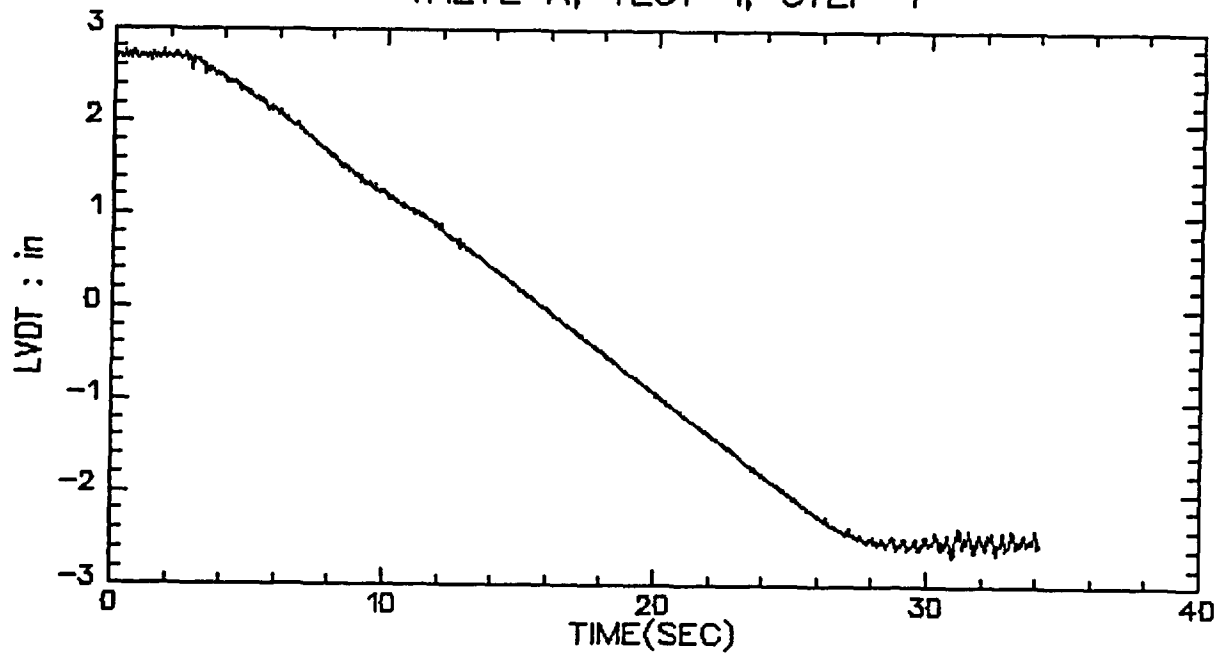

VALVE A, TEST 1, STEP 1

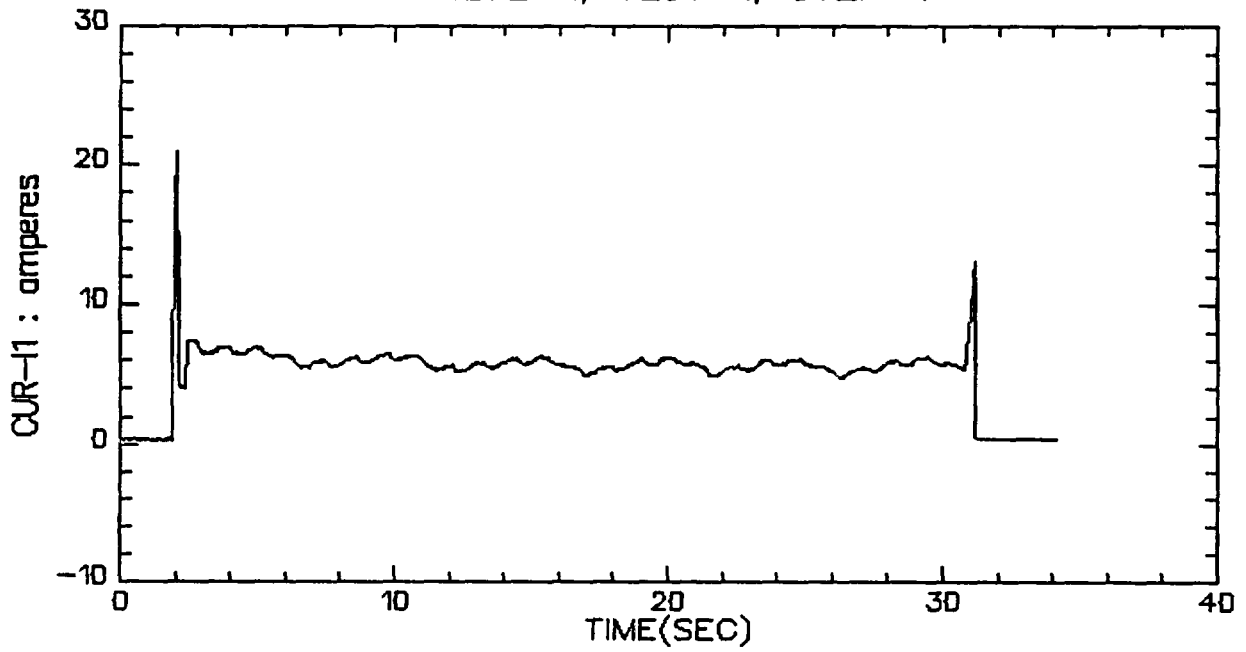

VALVE A, TEST 1, STEP 1

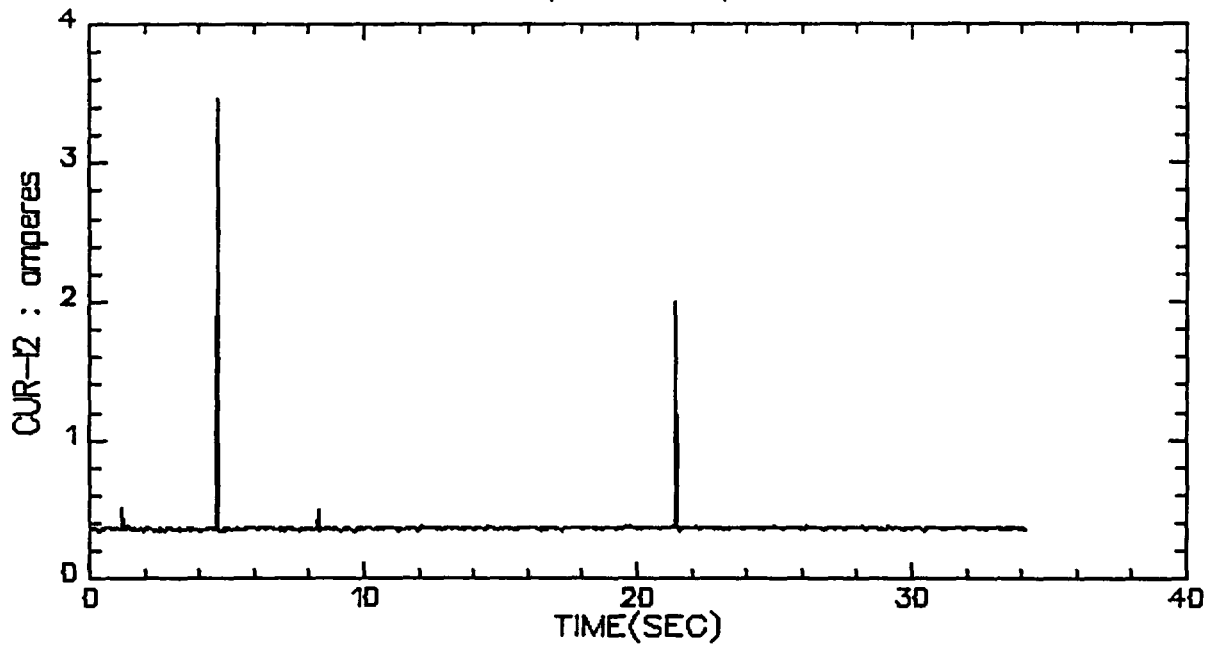

VALVE A, TEST 1, STEP 1

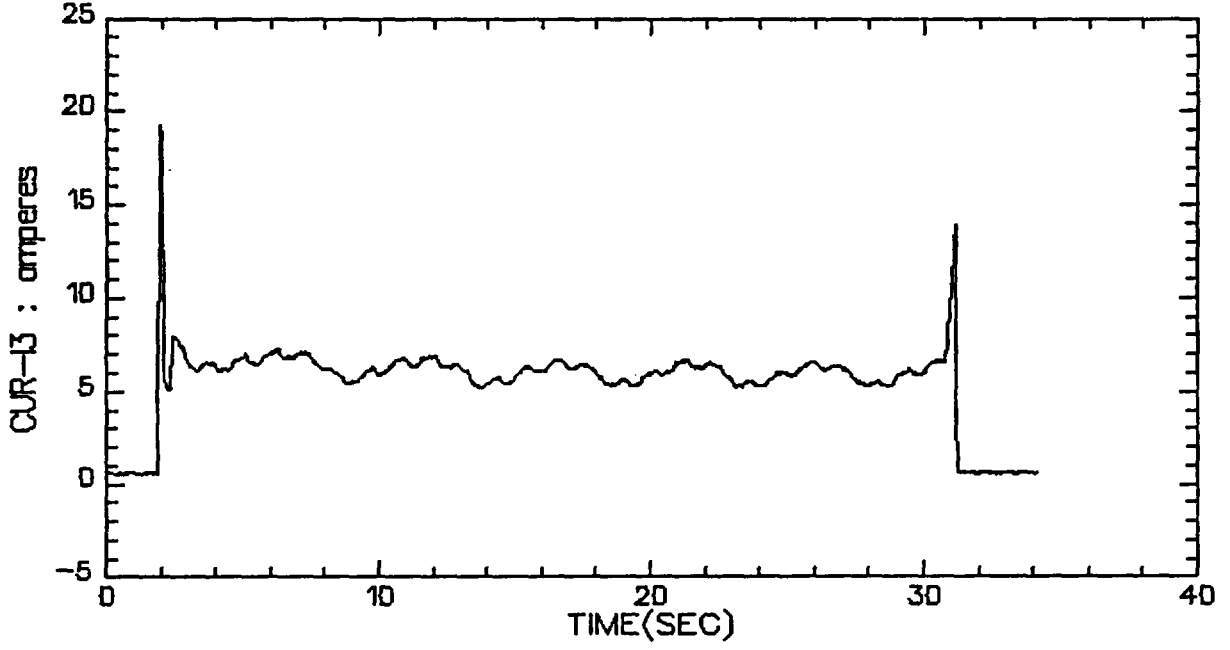

VALVE A, TEST 1, STEP 1

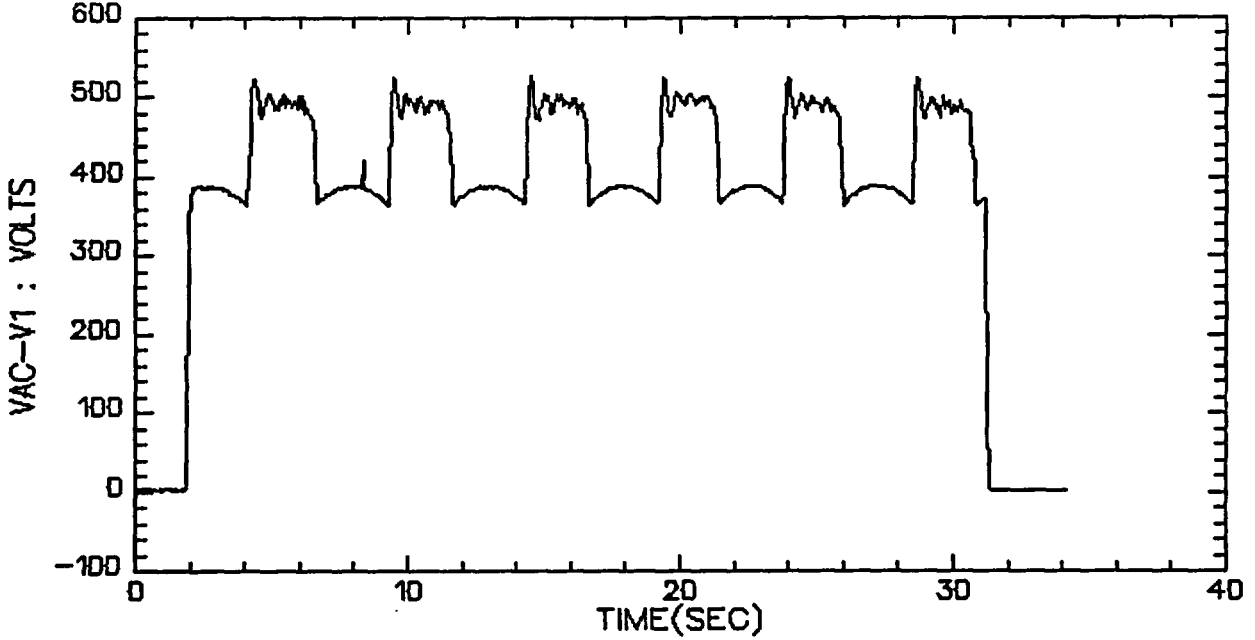

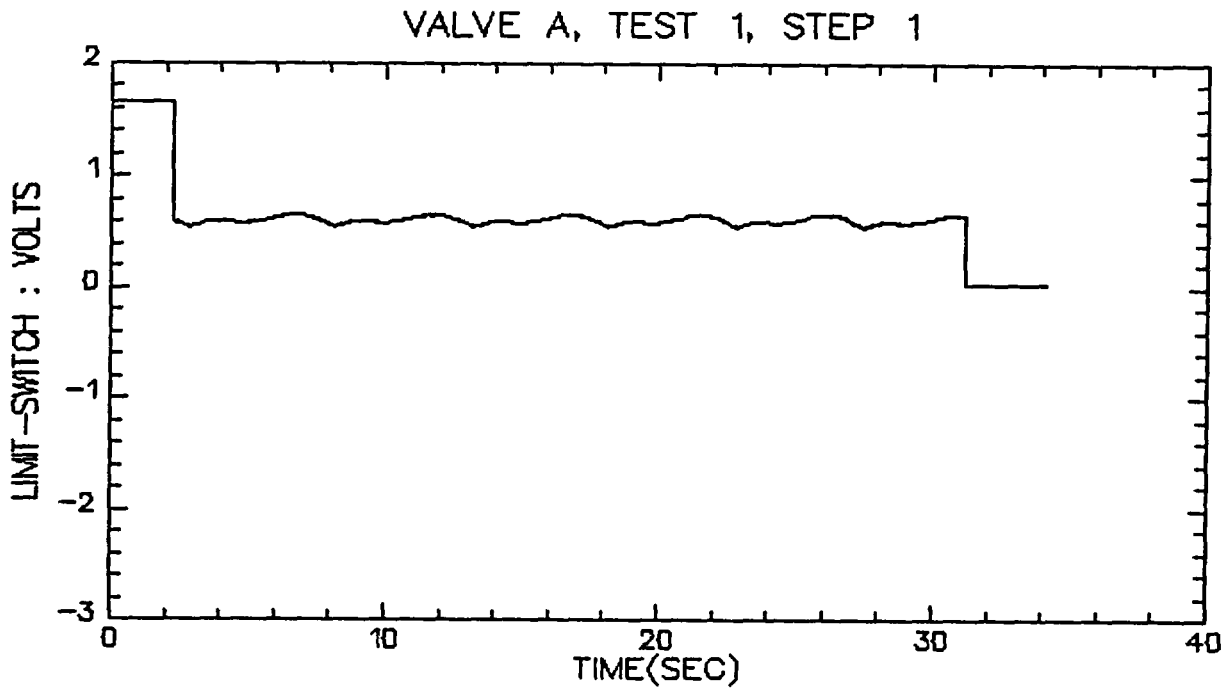
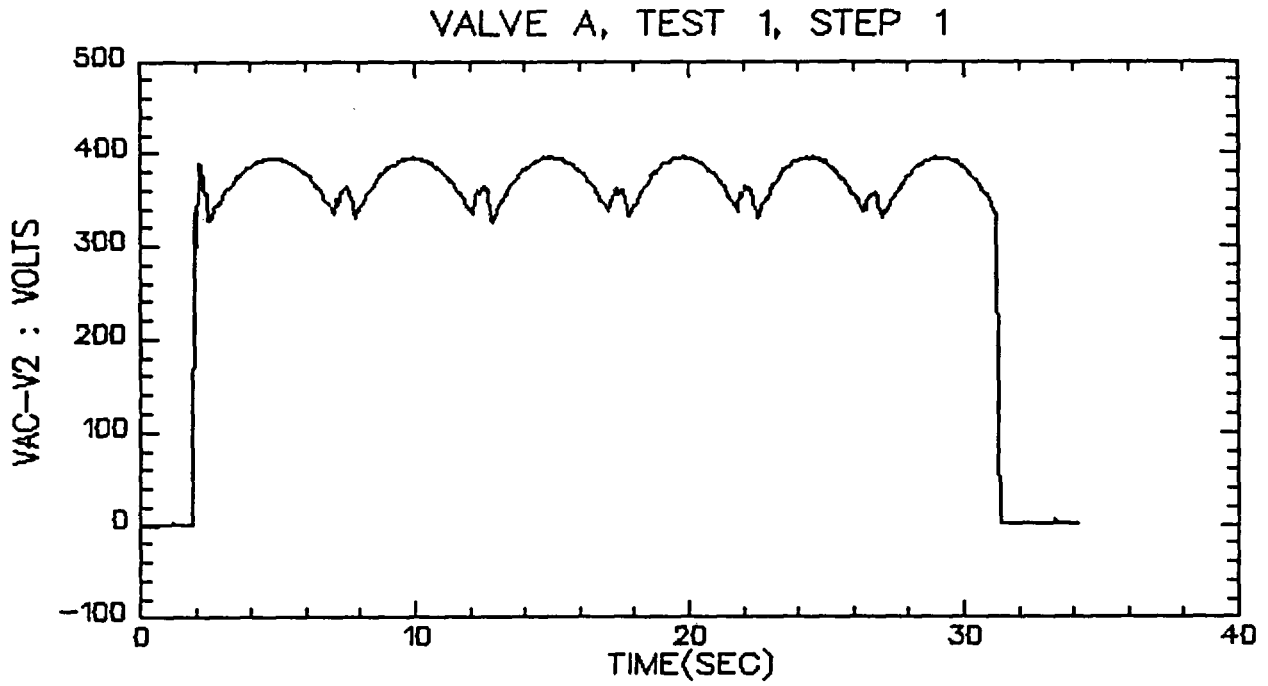

VALVE A, TEST 1, STEP 1

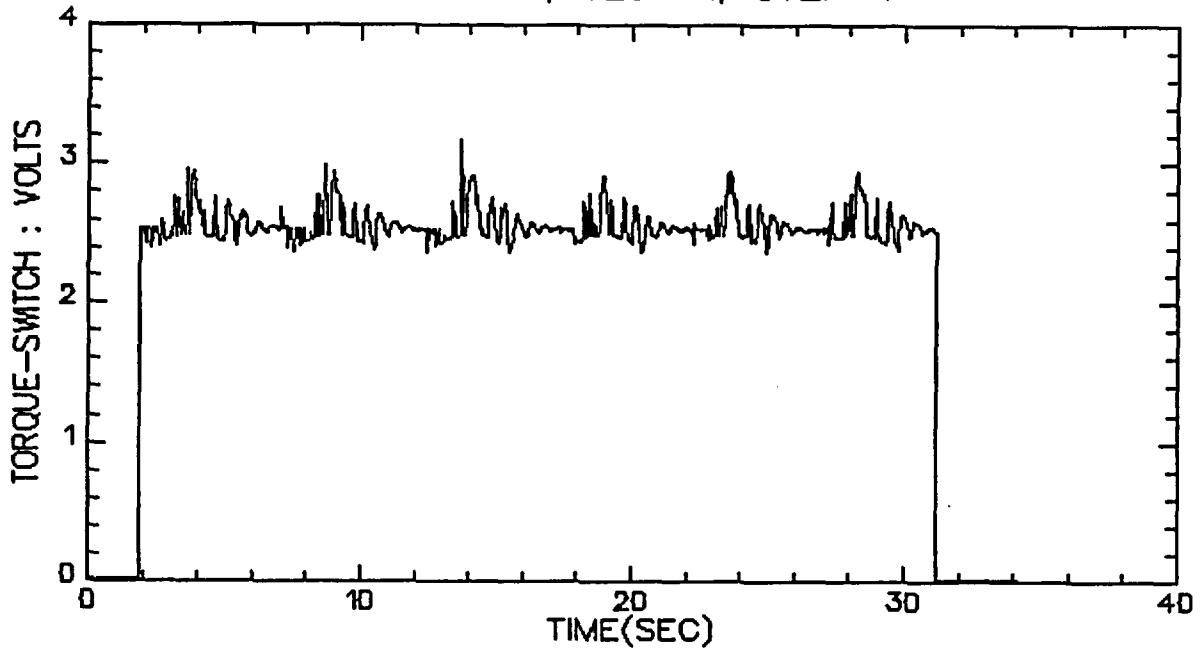

VALVE A, TEST 1, STEP 1

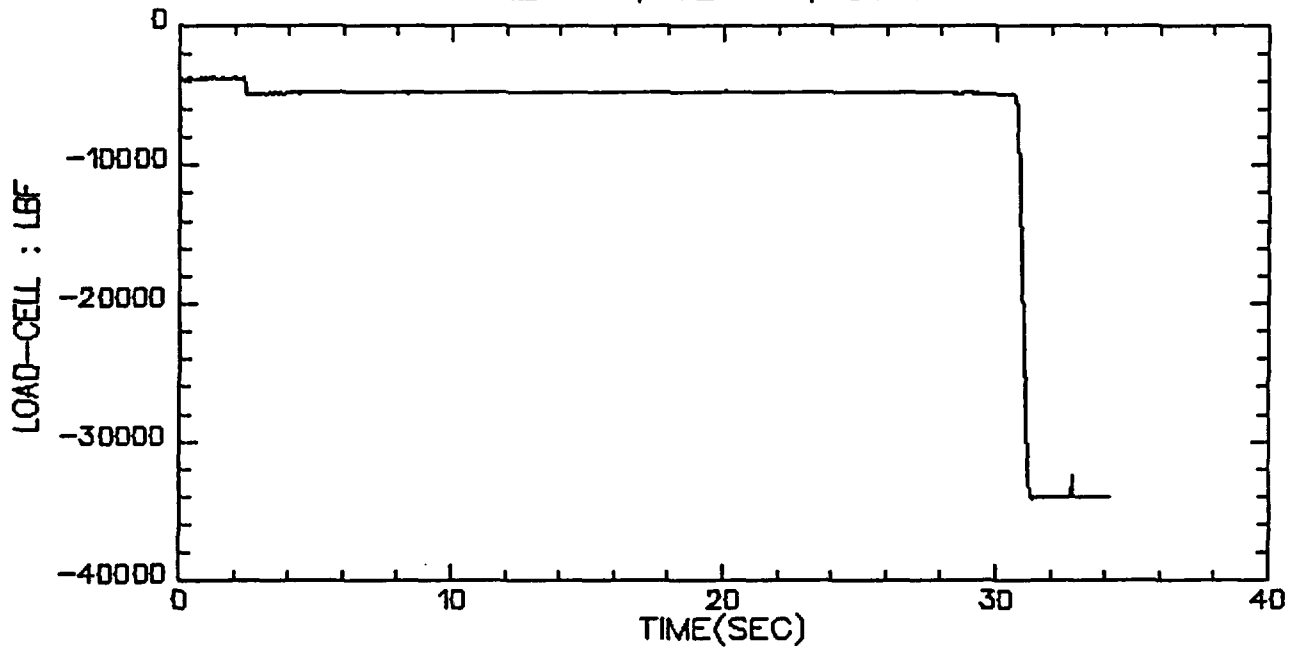

VALVE A, TEST 1, STEP 3

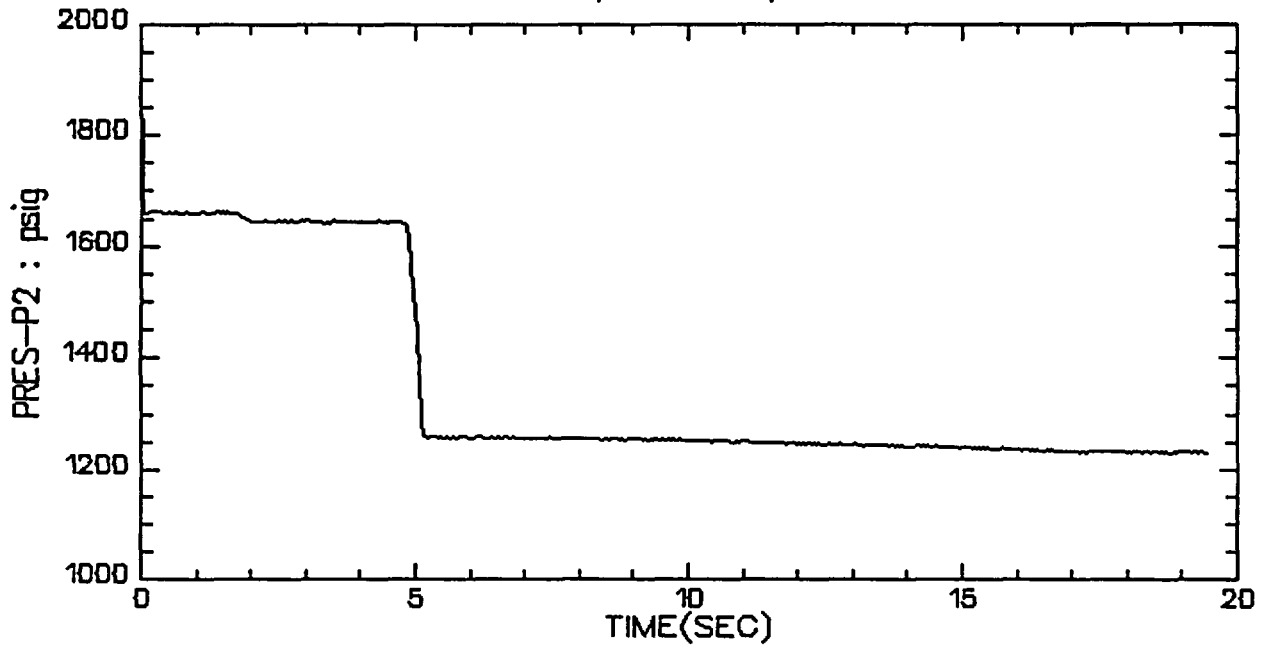

VALVE A, TEST 1, STEP 3

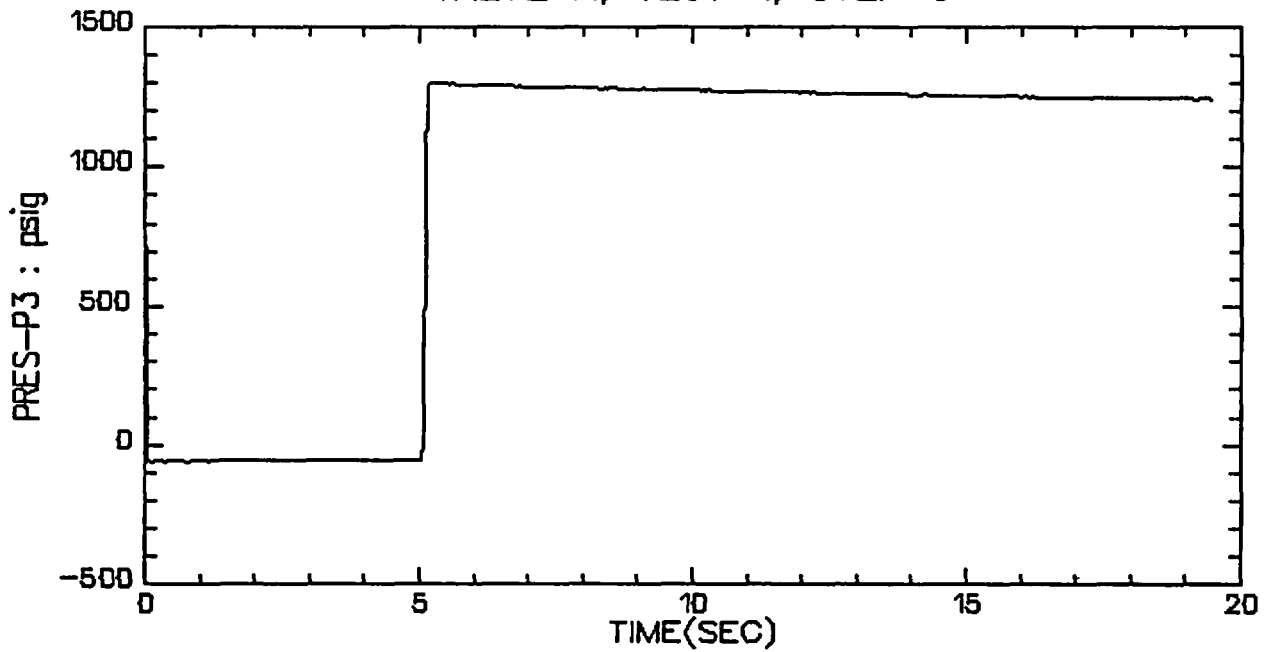

VALVE A, TEST 1, STEP 3

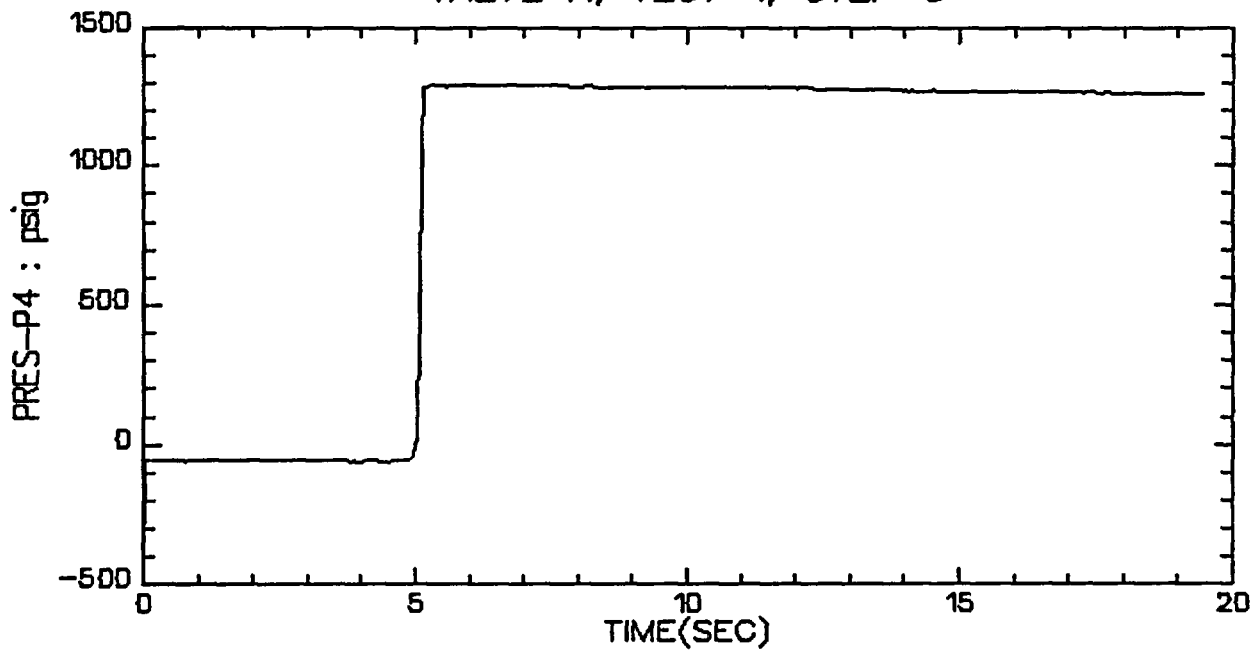

VALVE A, TEST 1, STEP 3

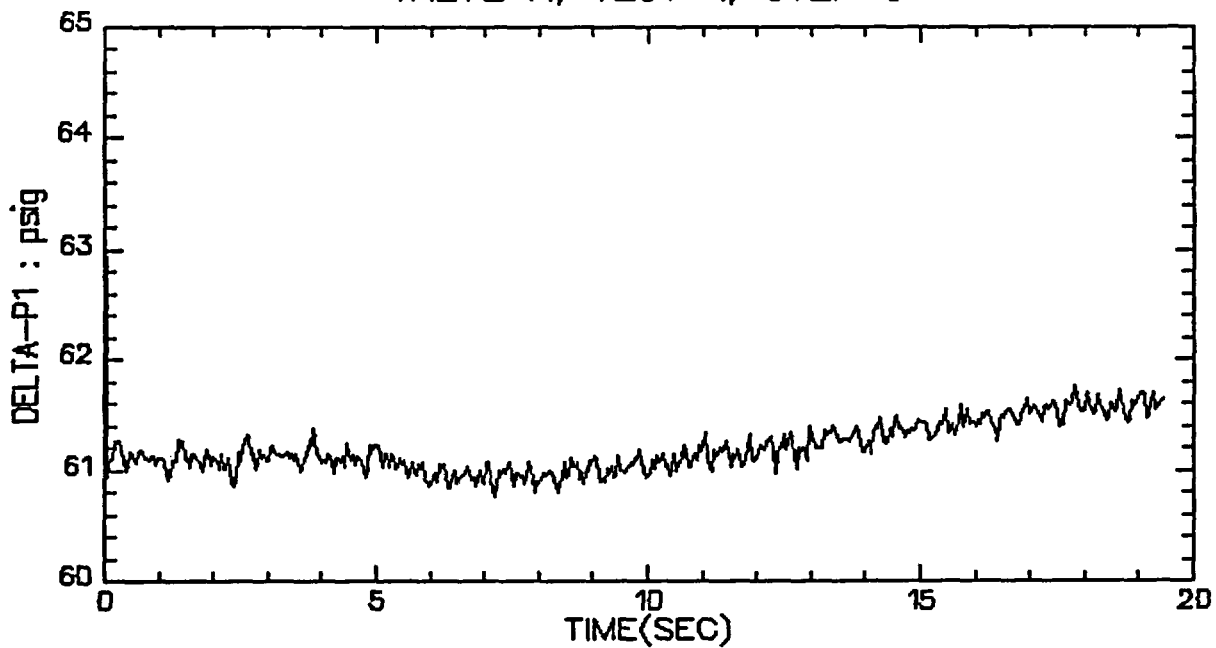

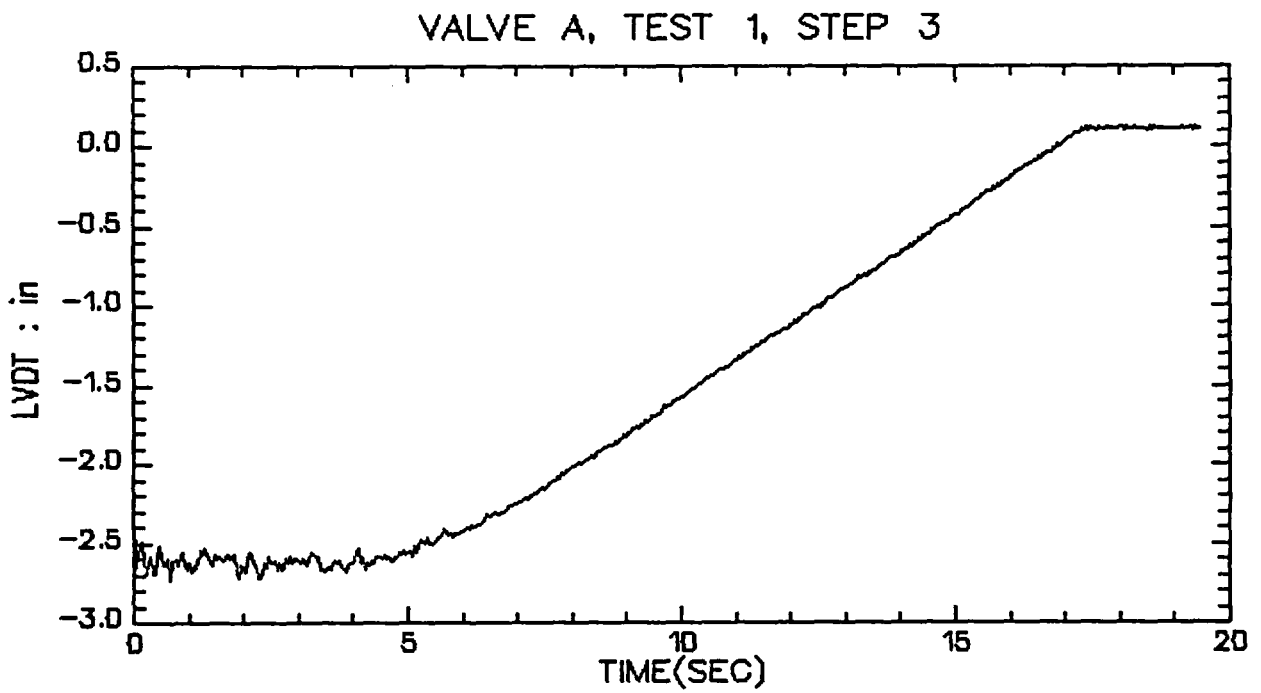
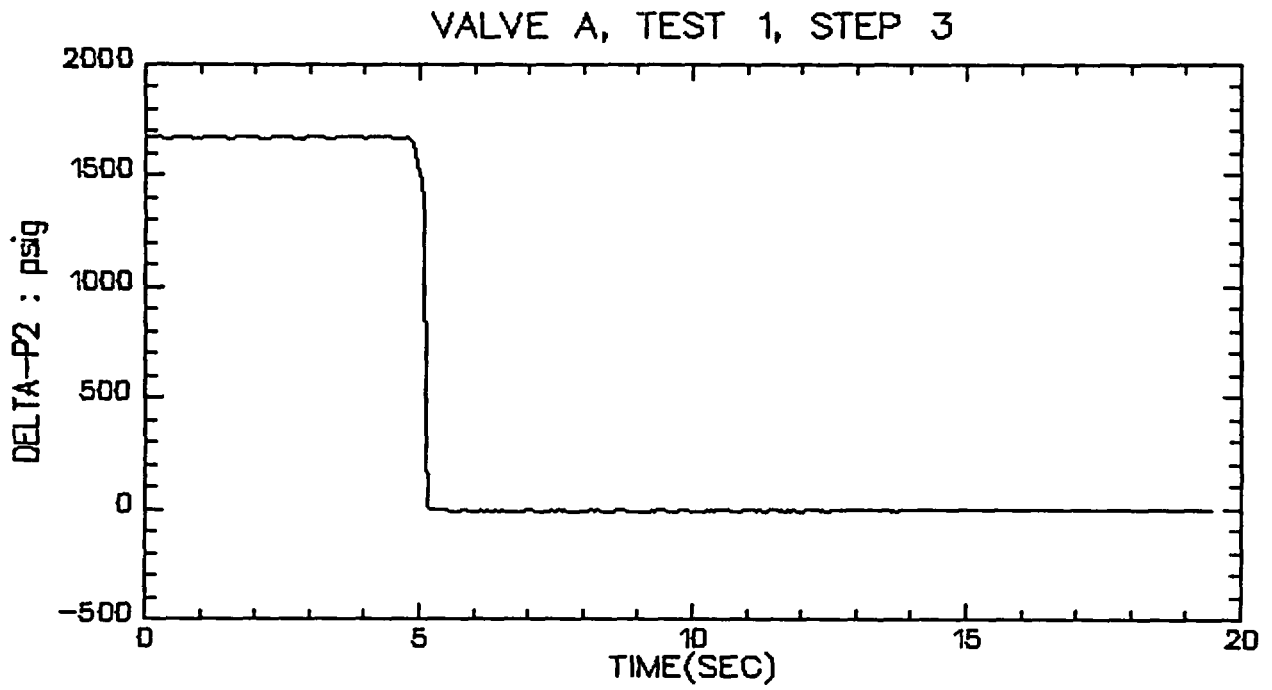

VALVE A, TEST 1, STEP 3

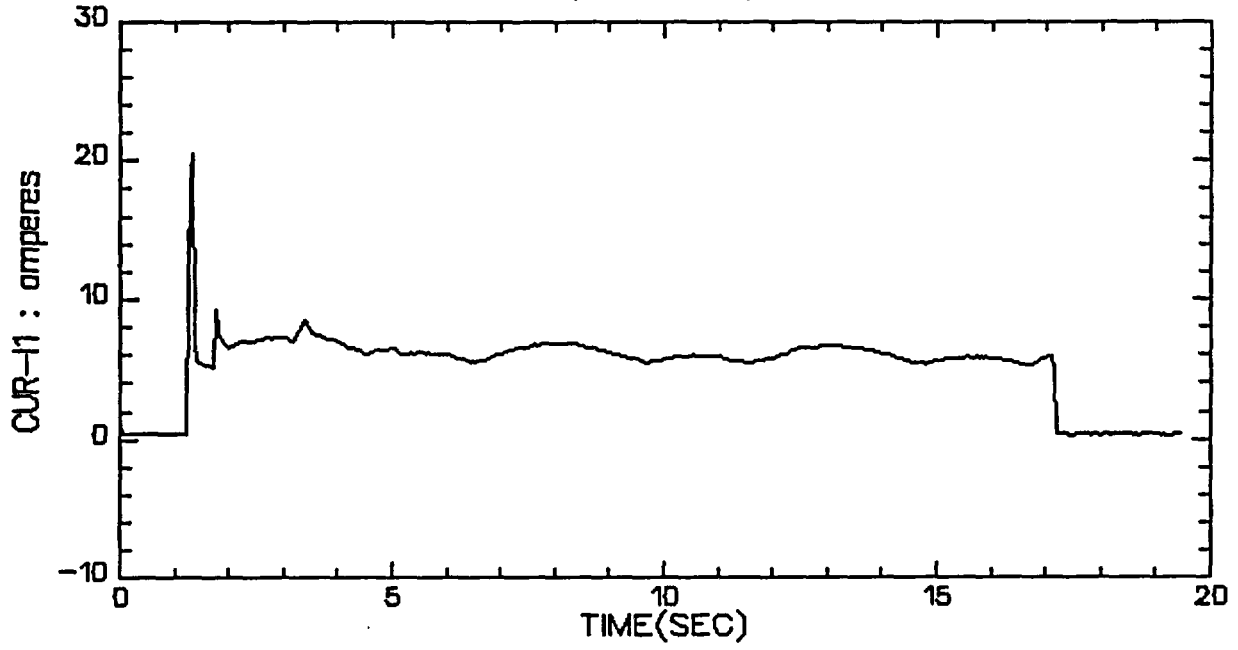

VALVE A, TEST 1, STEP 3

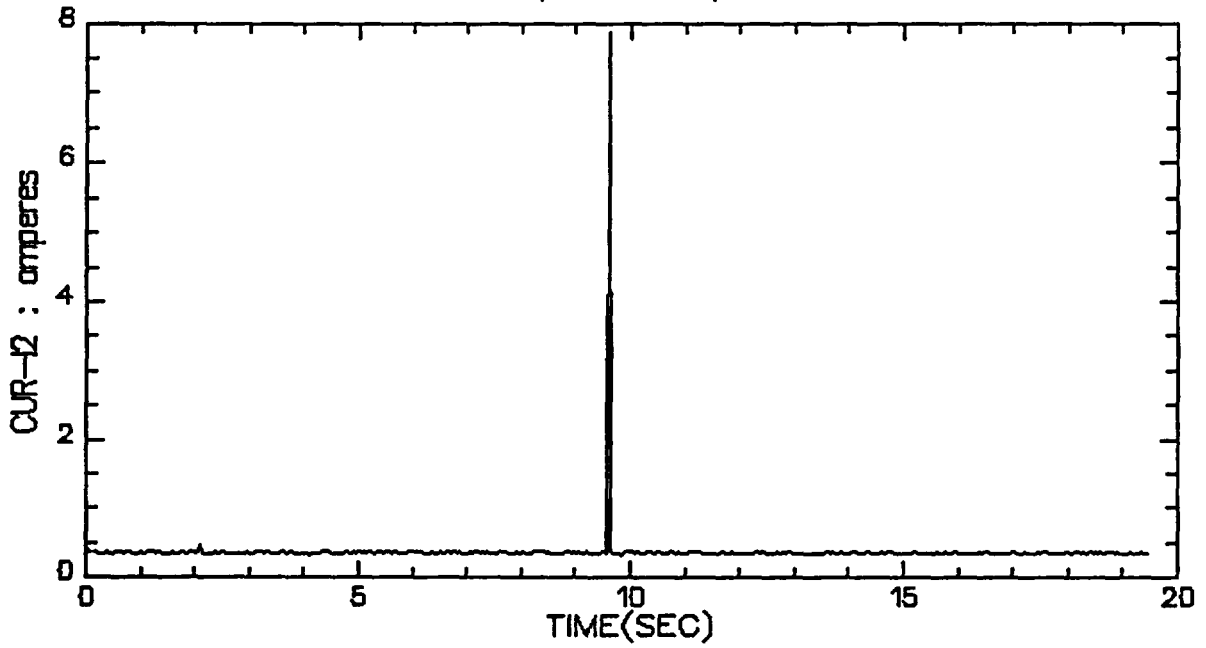

VALVE A, TEST 1, STEP 3

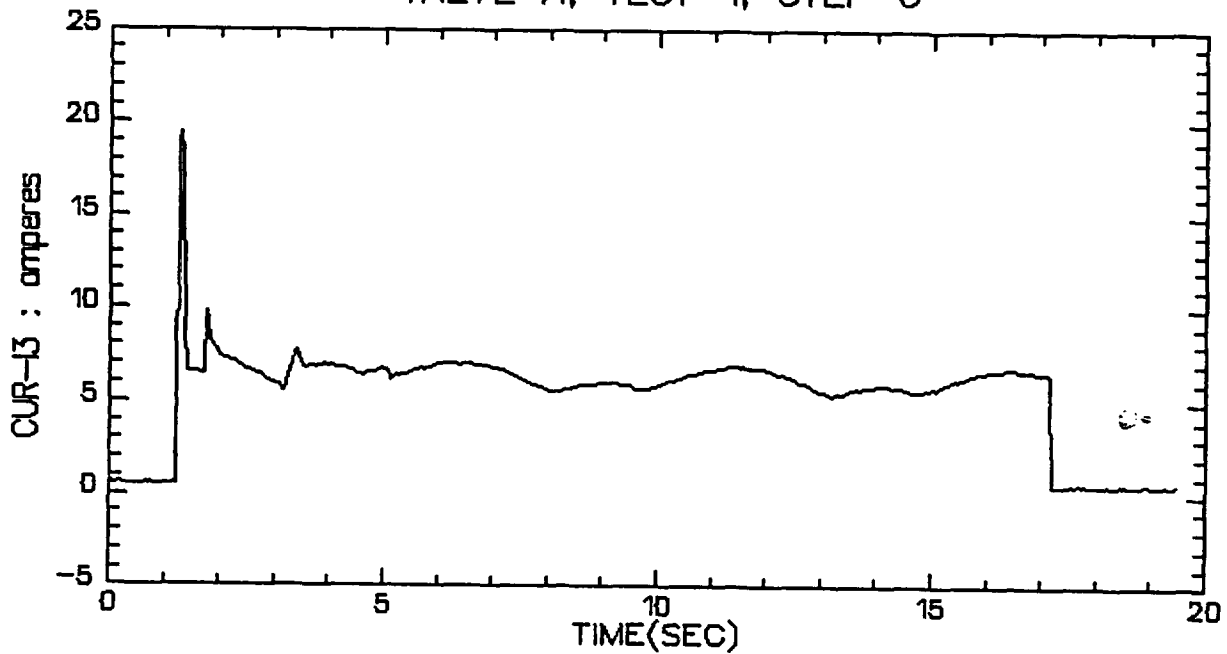

VALVE A, TEST 1, STEP 3

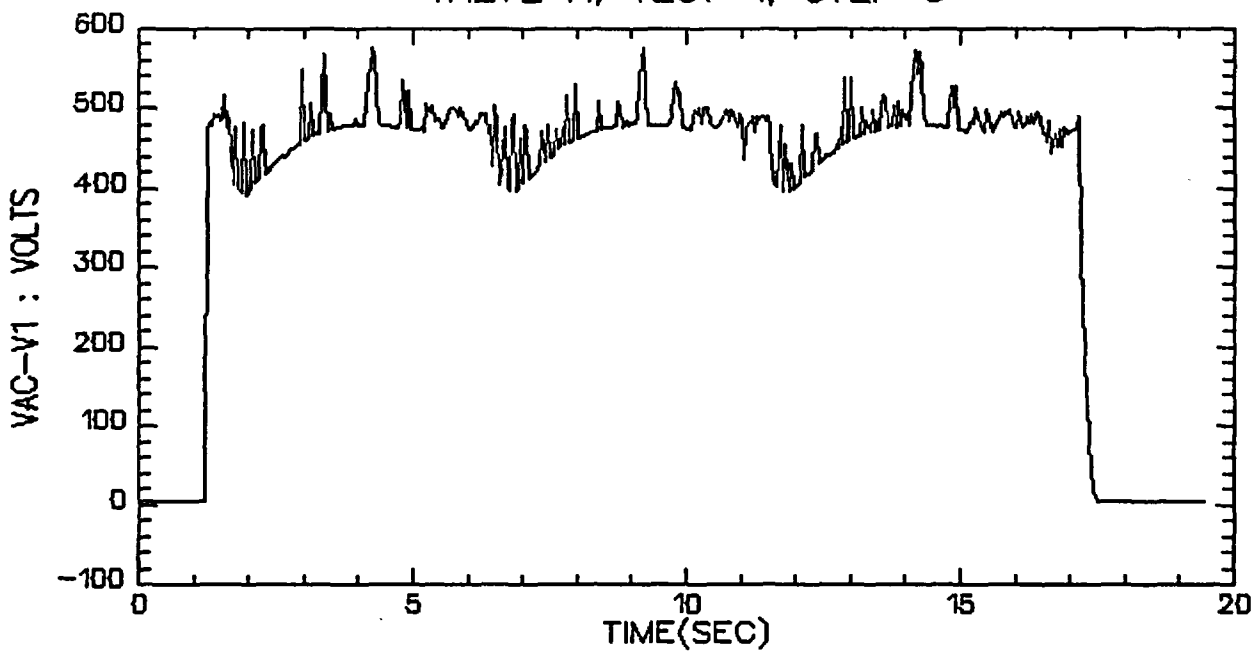

VALVE A, TEST 1, STEP 3

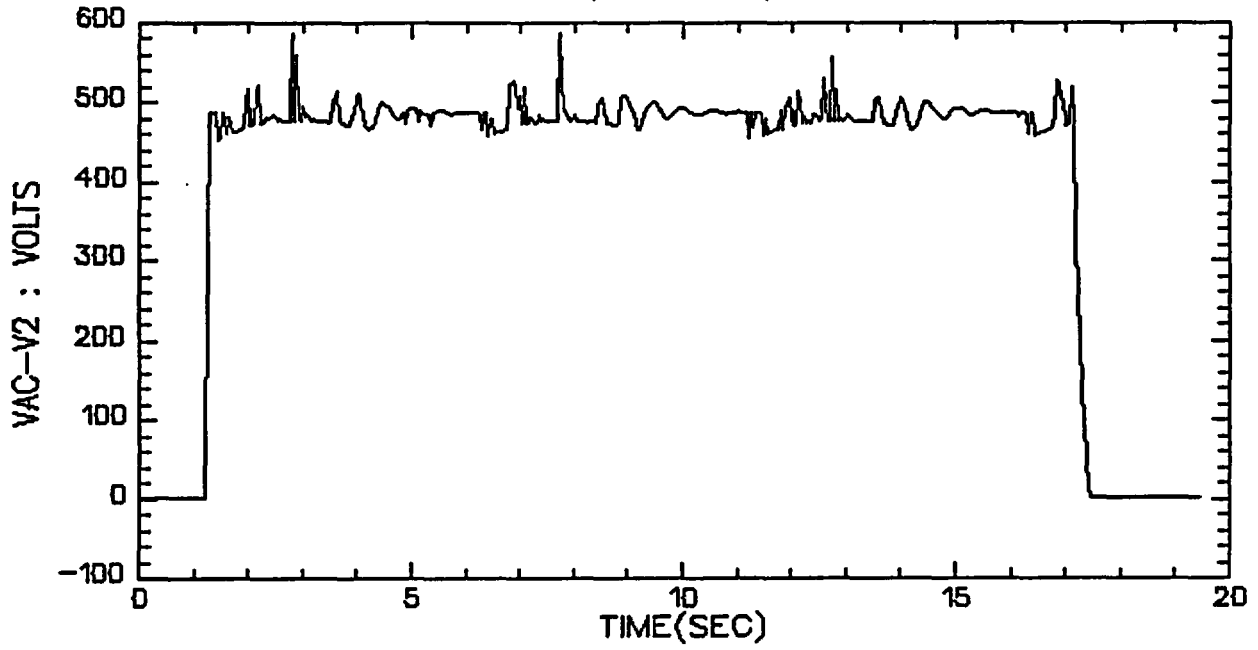

VALVE A, TEST 1, STEP 3

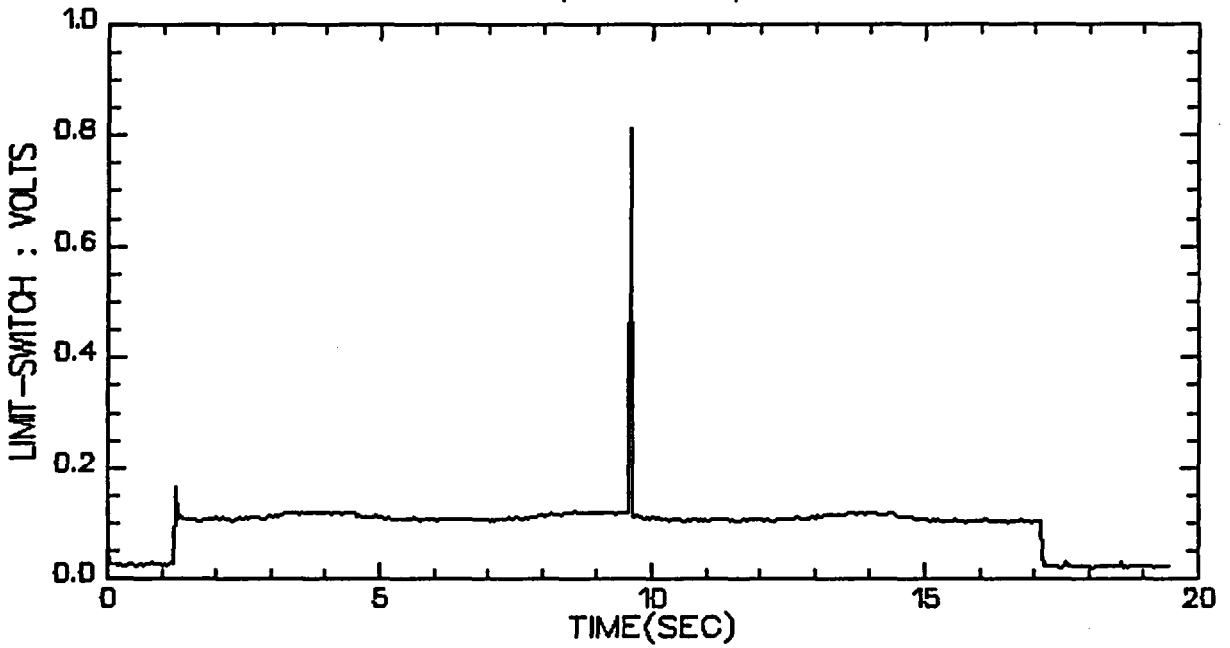

VALVE A, TEST 1, STEP 3

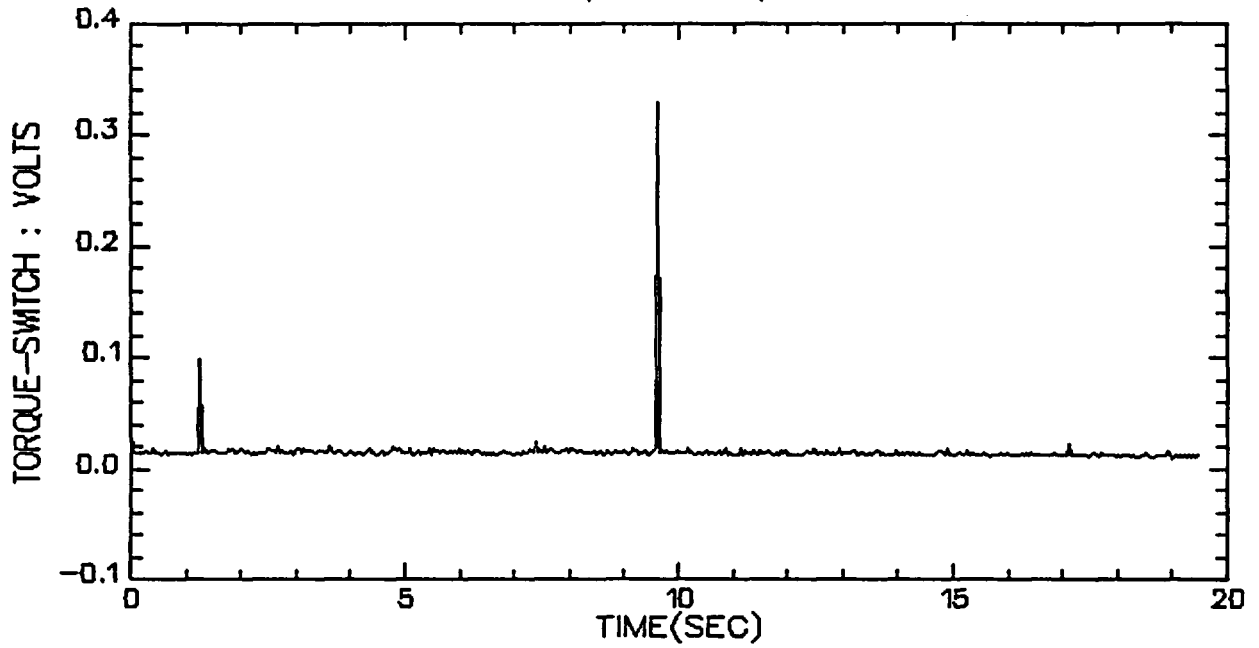

VALVE A, TEST 1, STEP 3

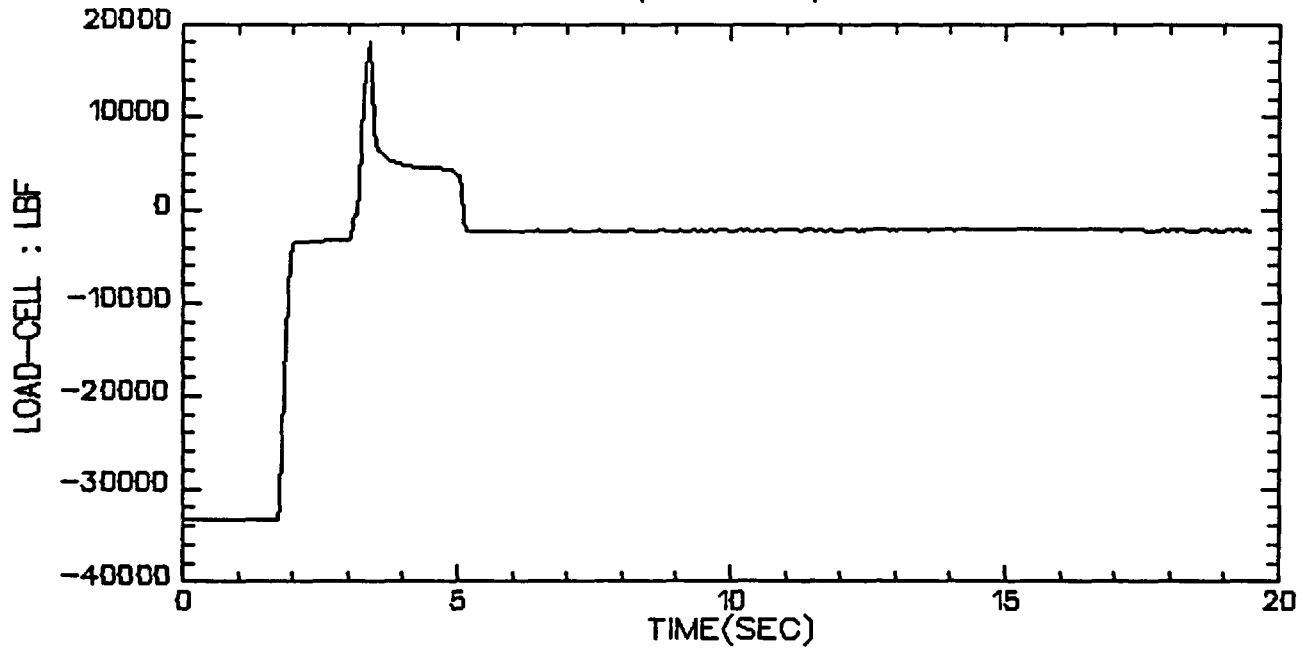

VALVE A, TEST 1, STEP 5

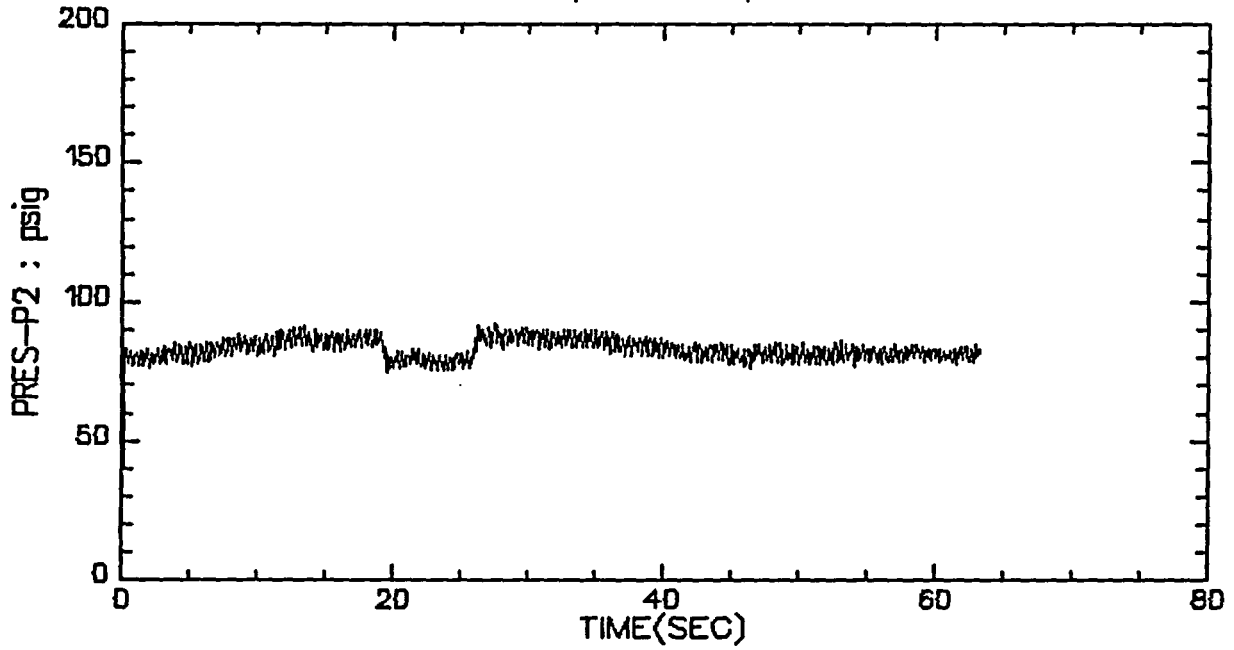

VALVE A, TEST 1, STEP 5

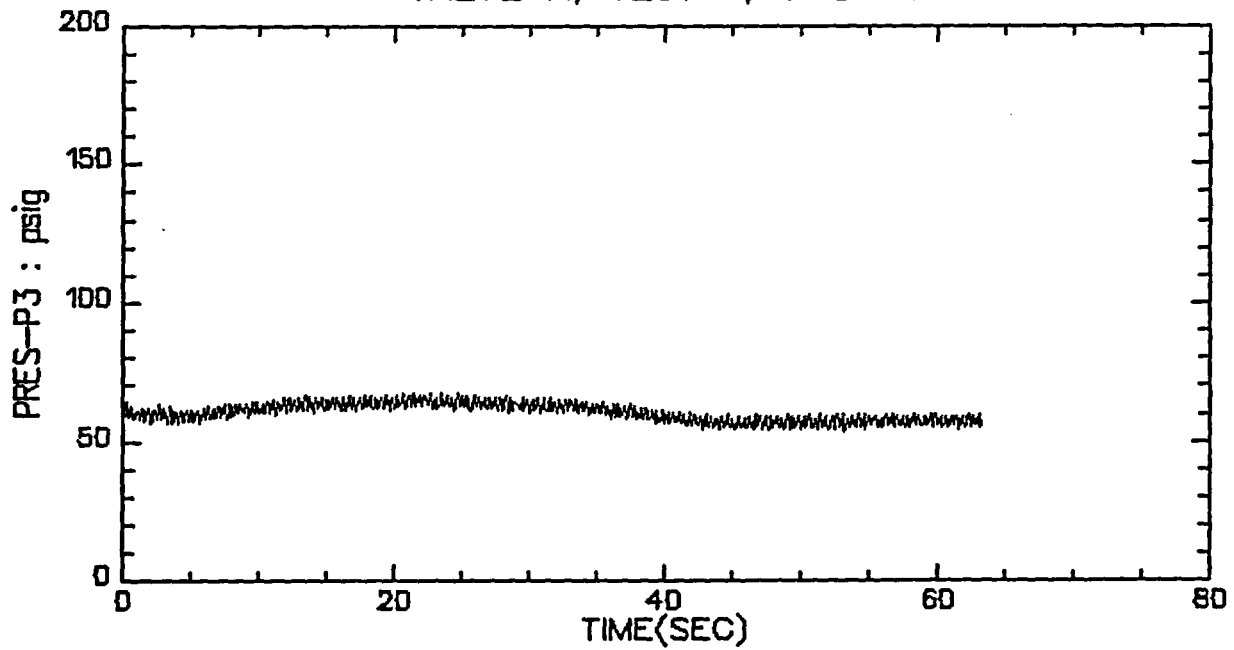

VALVE A, TEST 1, STEP 5

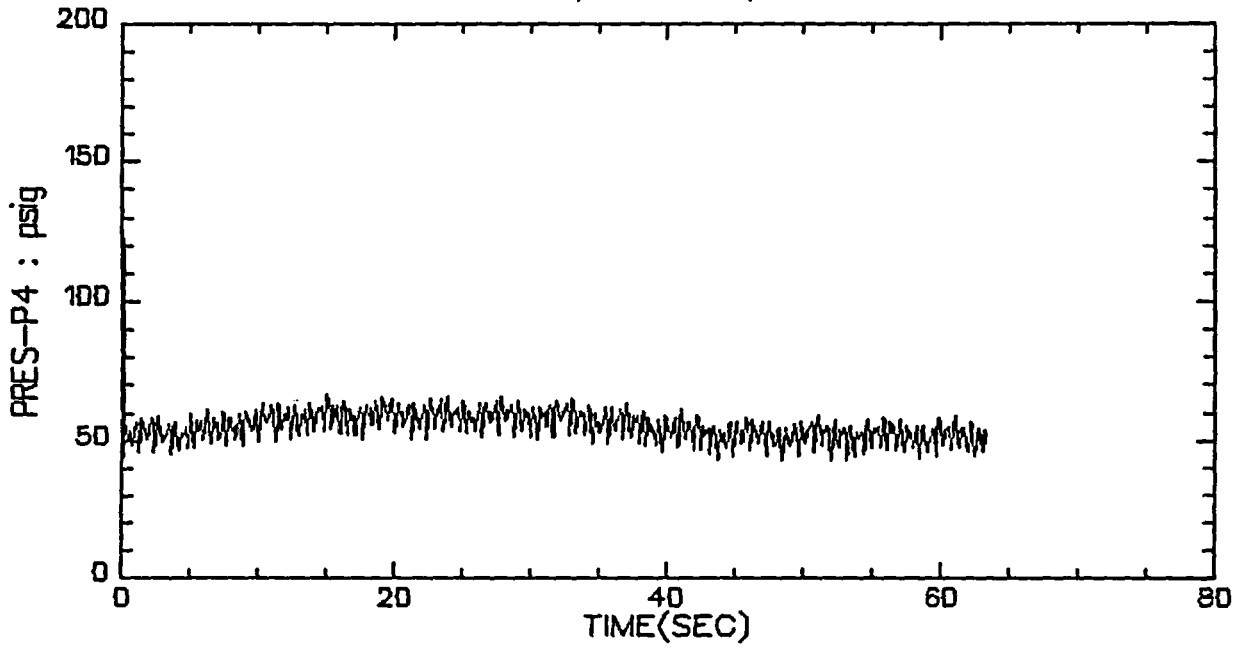

VALVE A, TEST 1, STEP 5

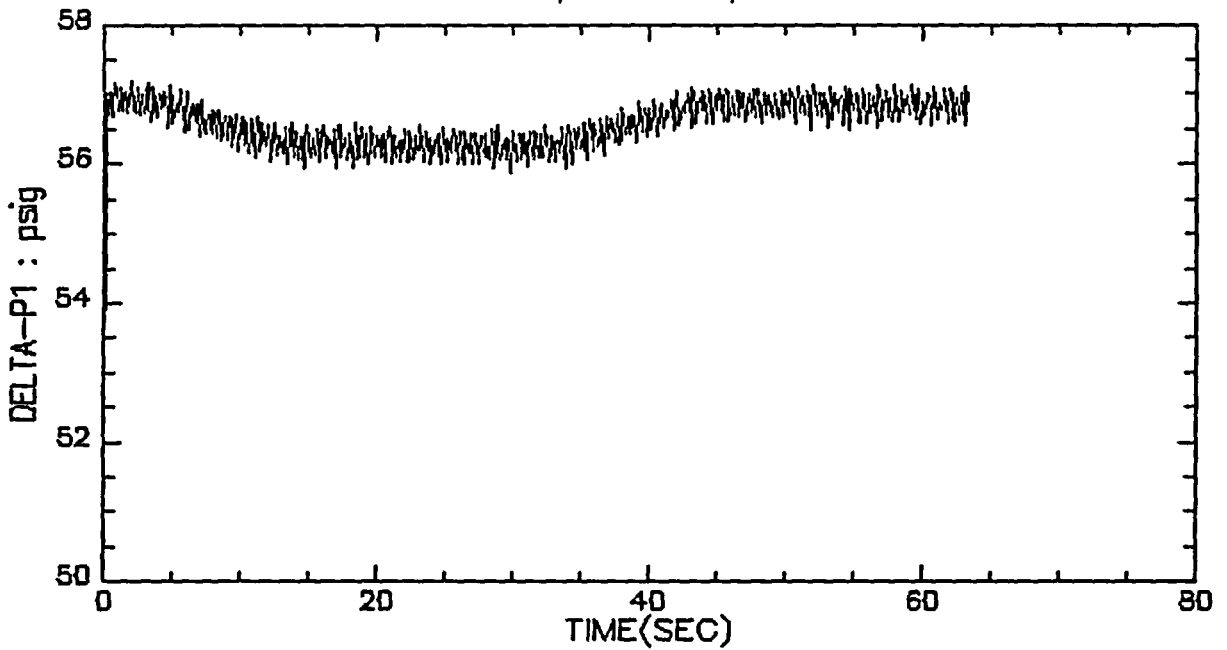

VALVE A, TEST 1, STEP 5

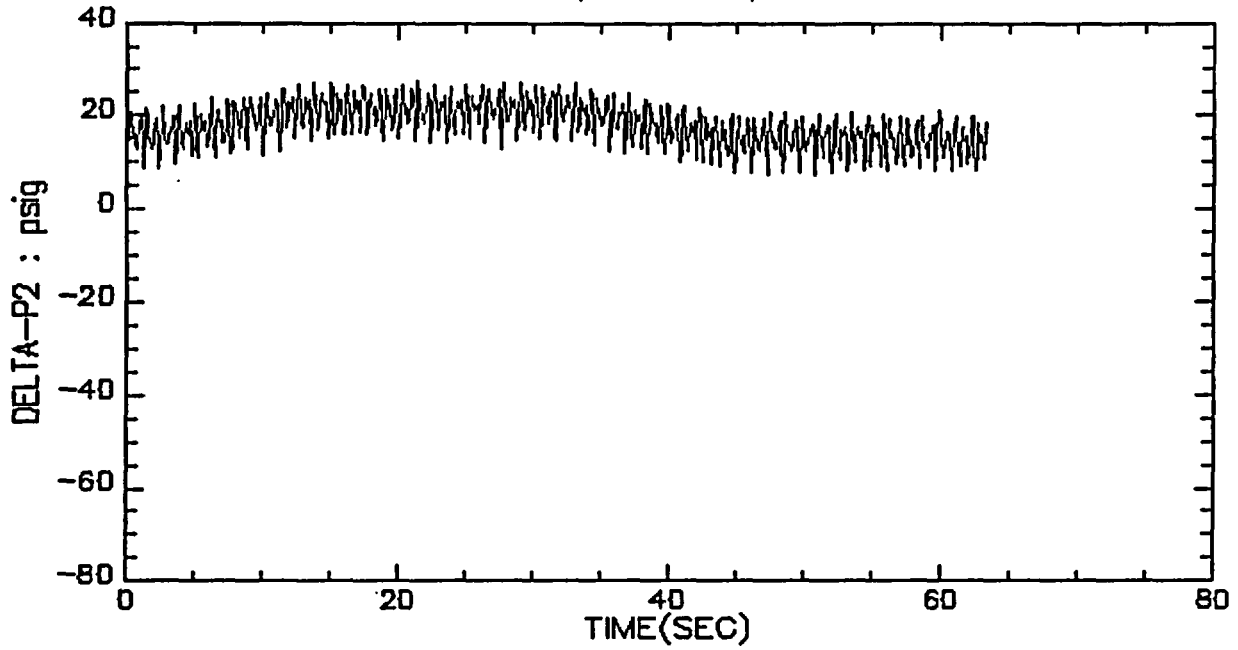

VALVE A, TEST 1, STEP 5

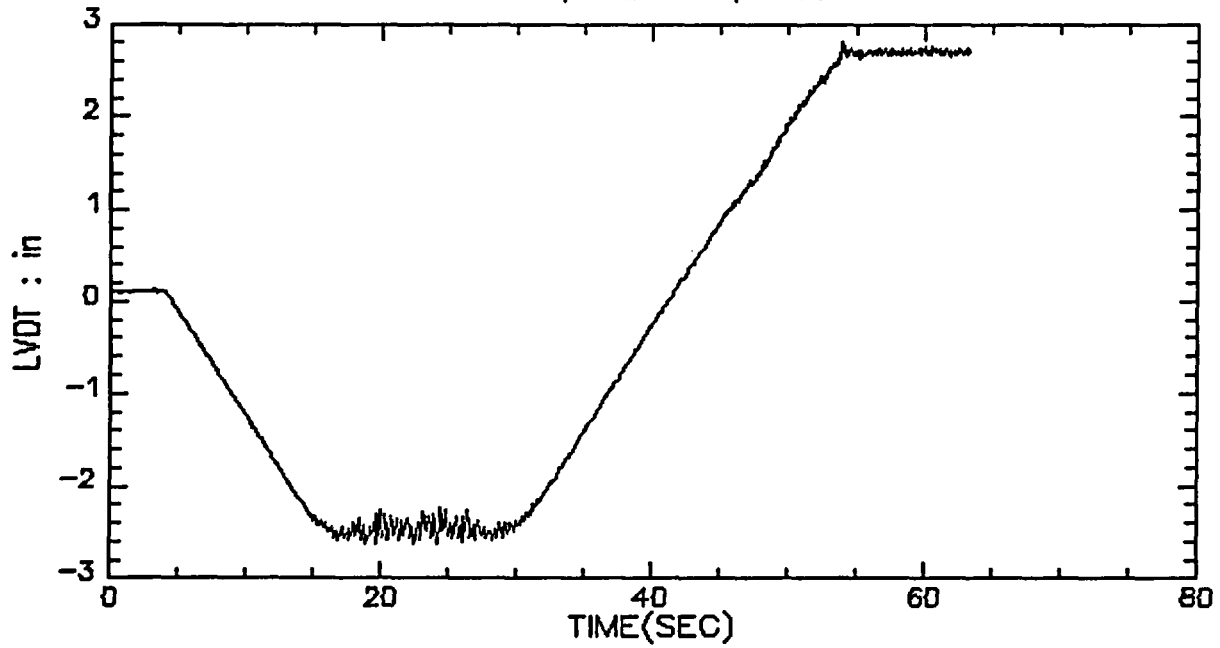

VALVE A, TEST 1, STEP 5

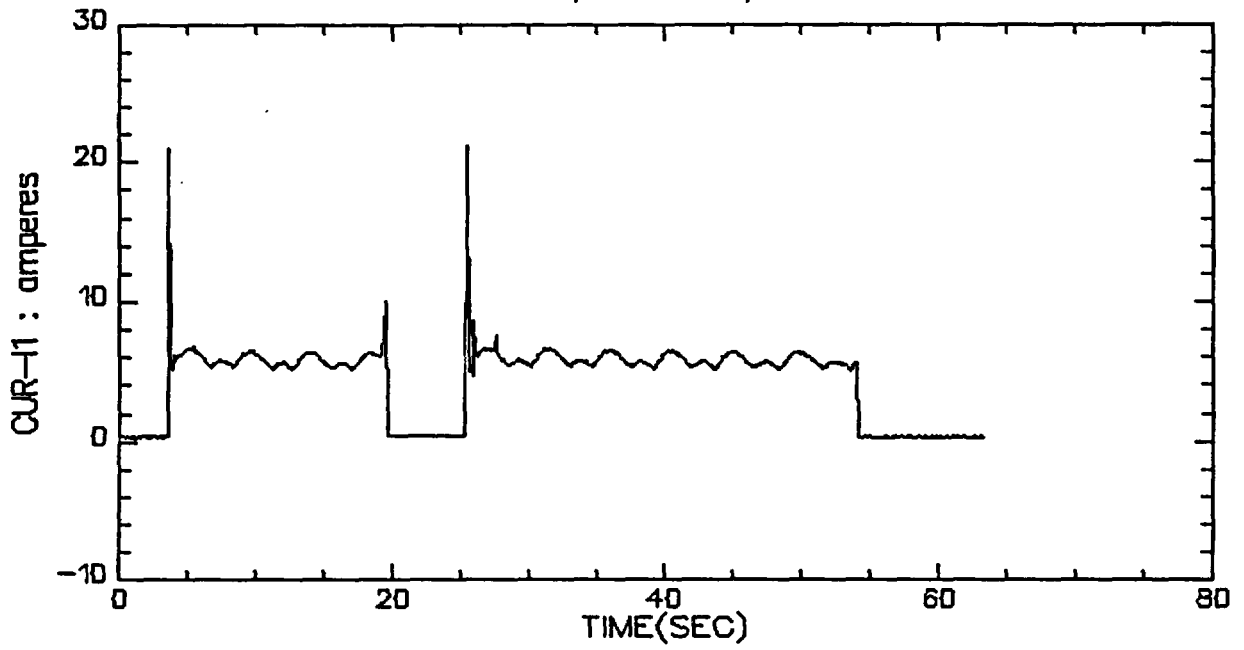

VALVE A, TEST 1, STEP 5

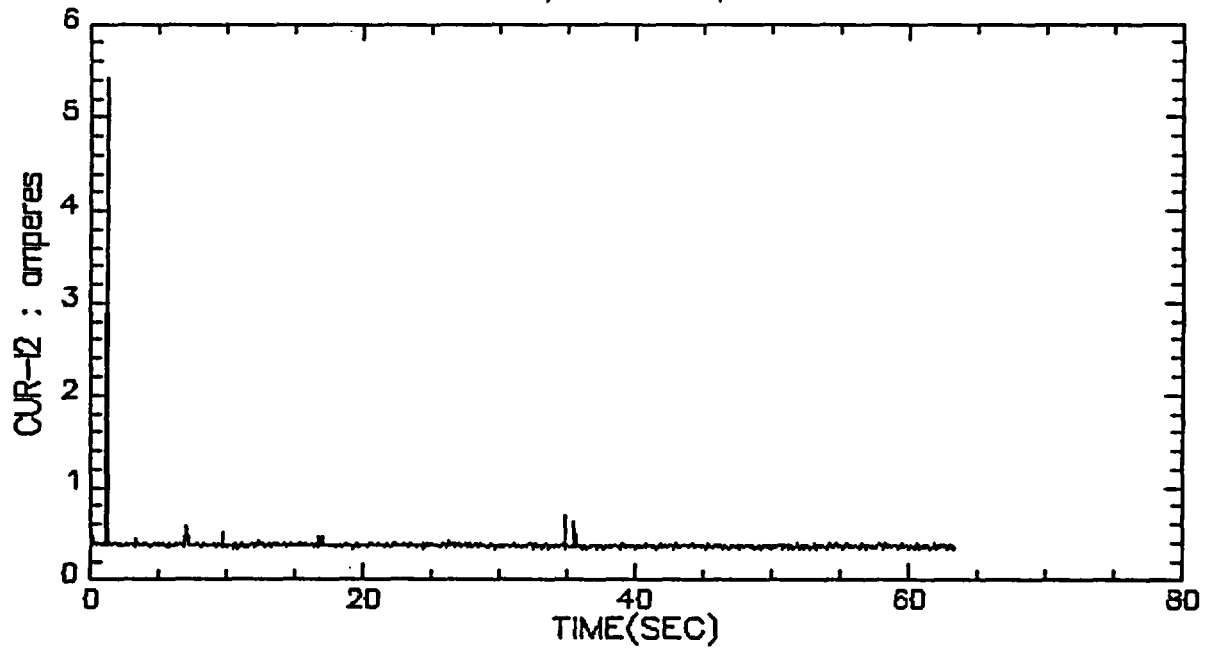

VALVE A, TEST 1, STEP 5

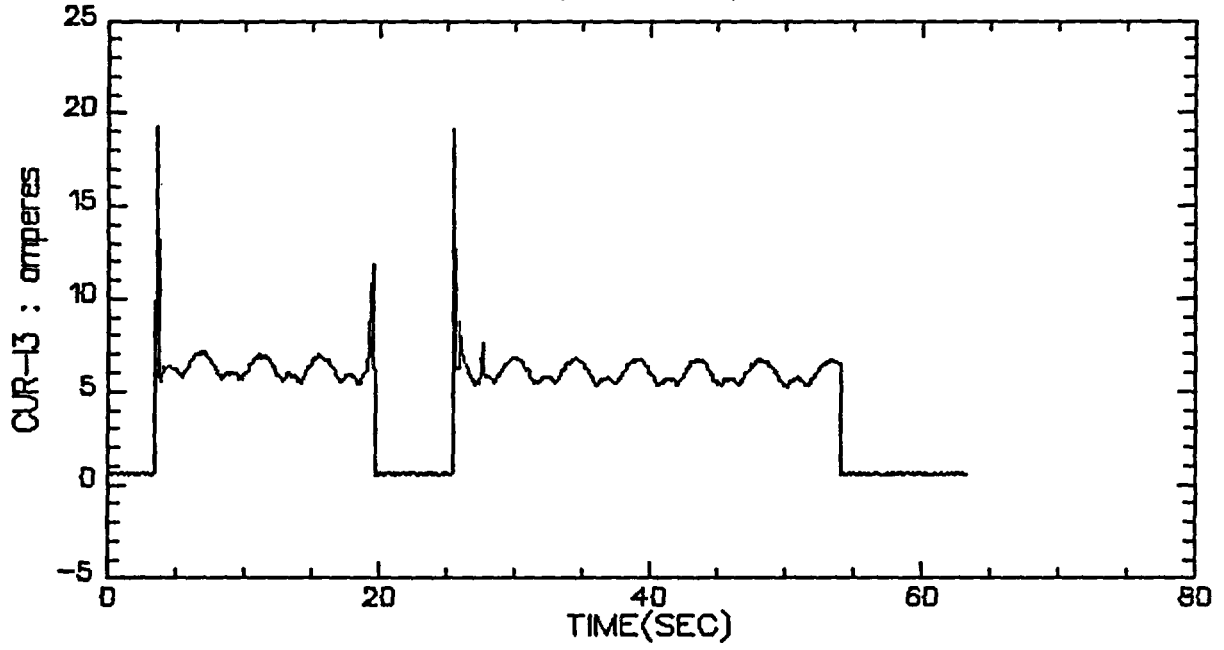

VALVE A, TEST 1, STEP 5

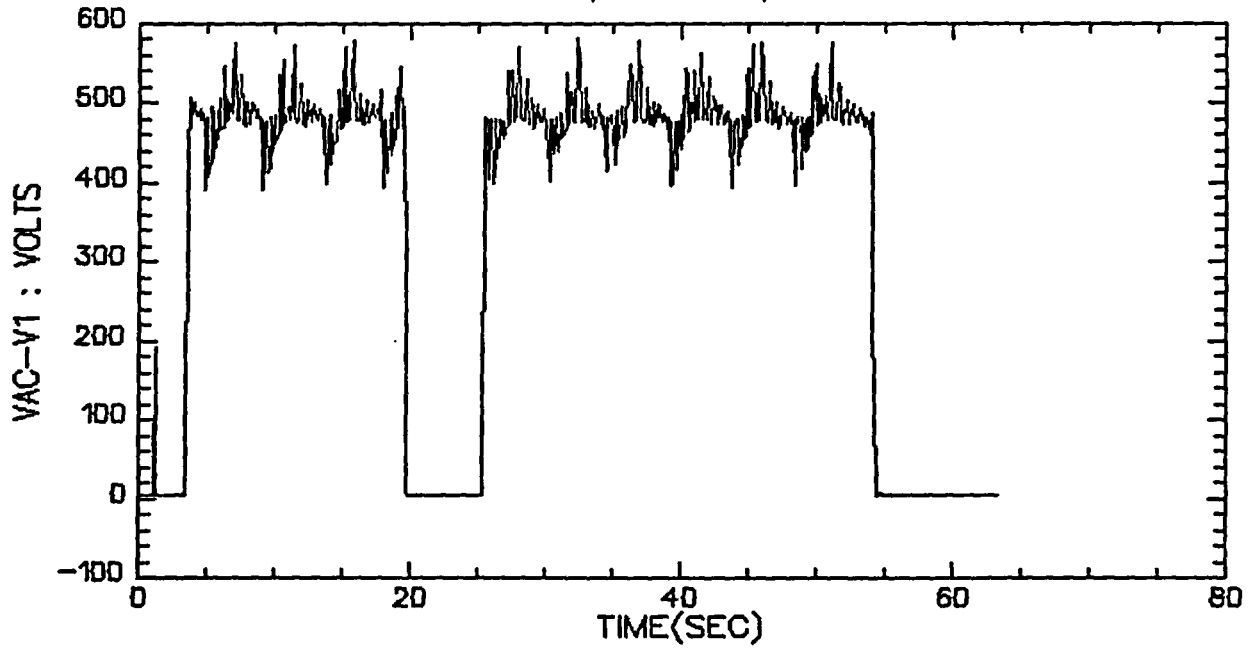

VALVE A, TEST 1, STEP 5

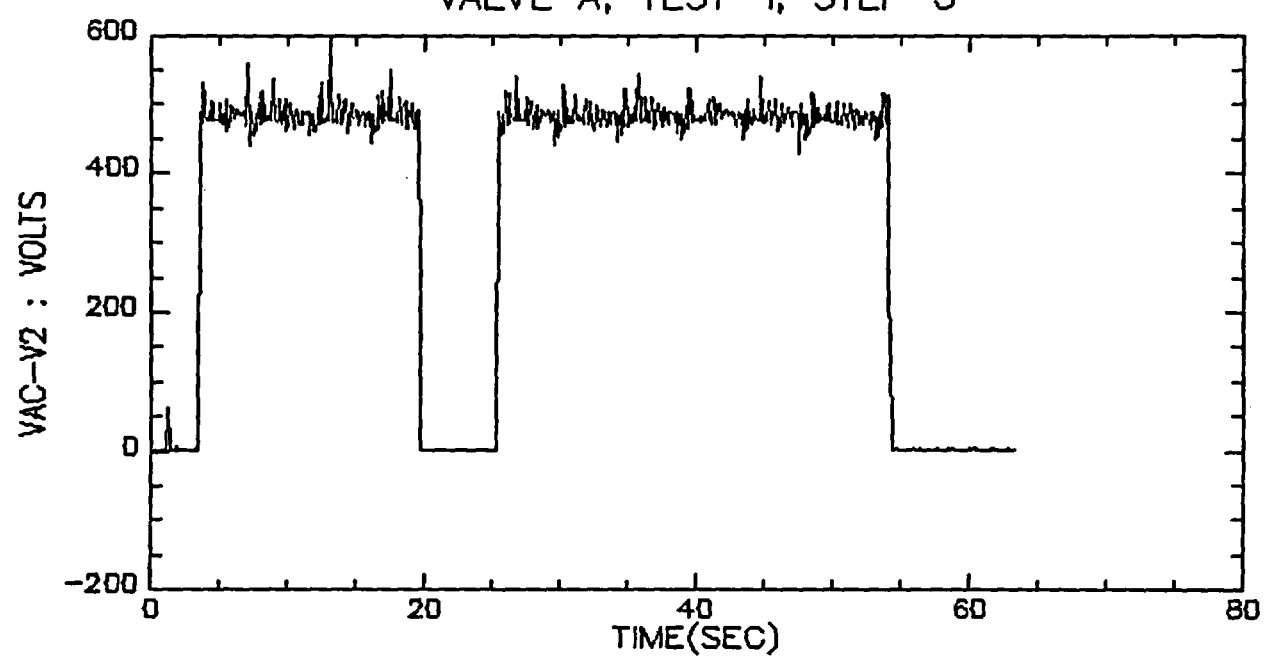

VALVE A, TEST 1, STEP 5

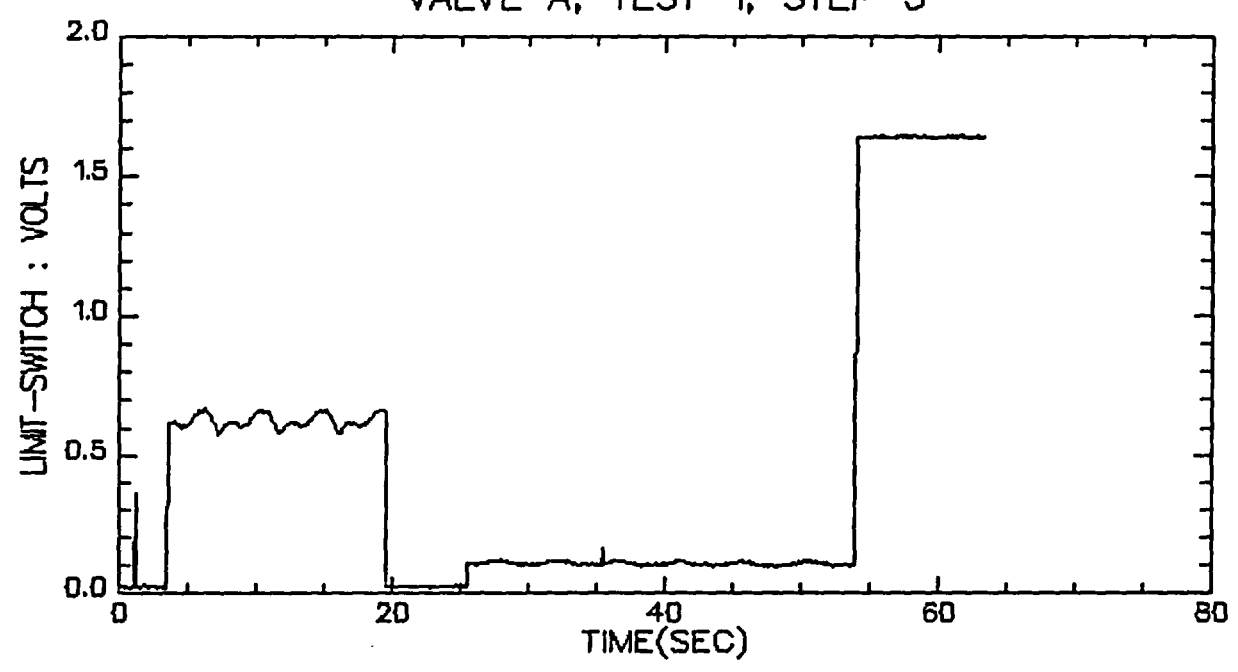

VALVE A, TEST 1, STEP 5

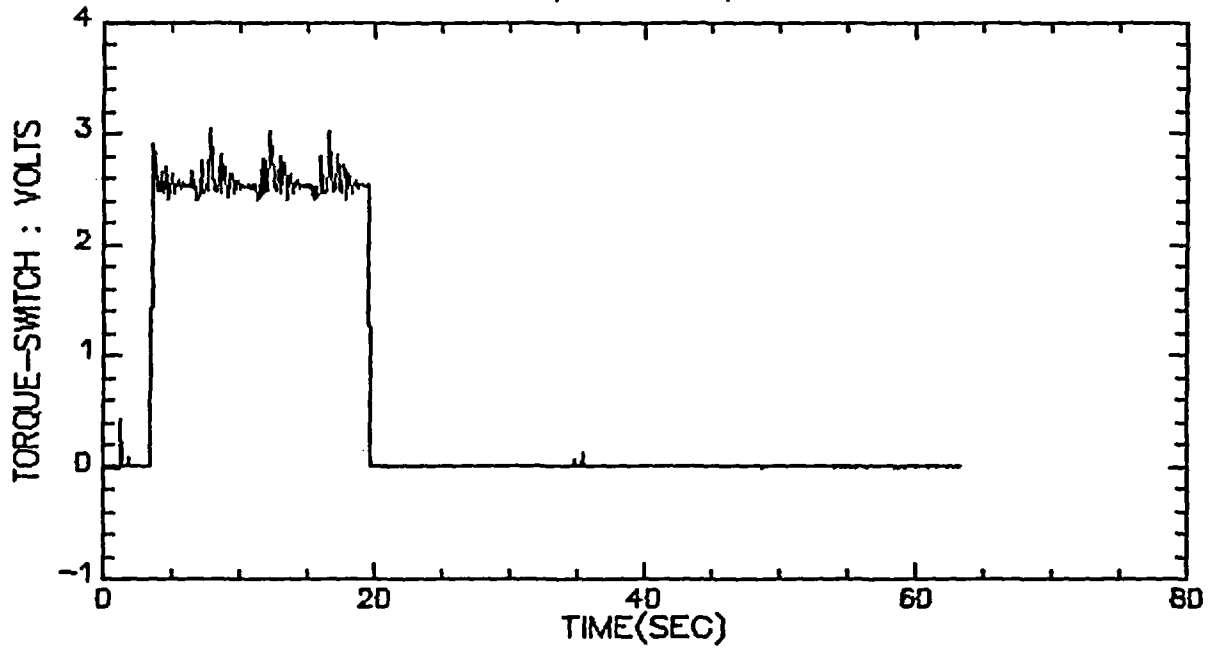

VALVE A, TEST 1, STEP 5

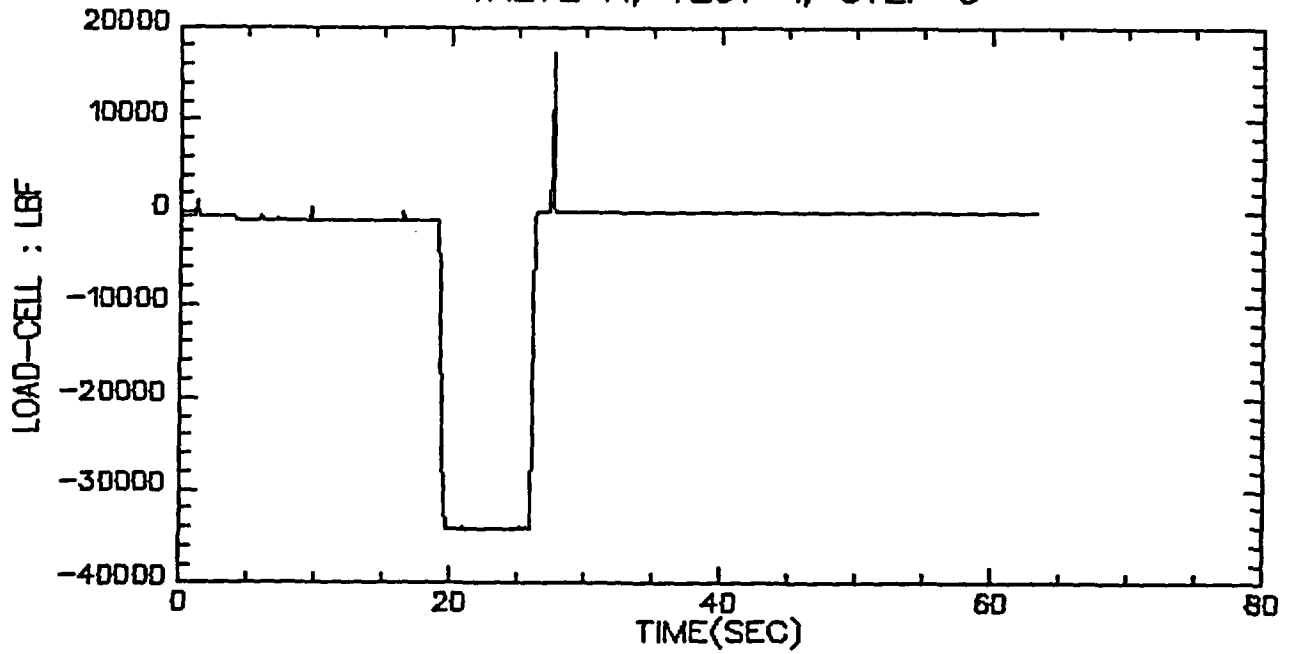

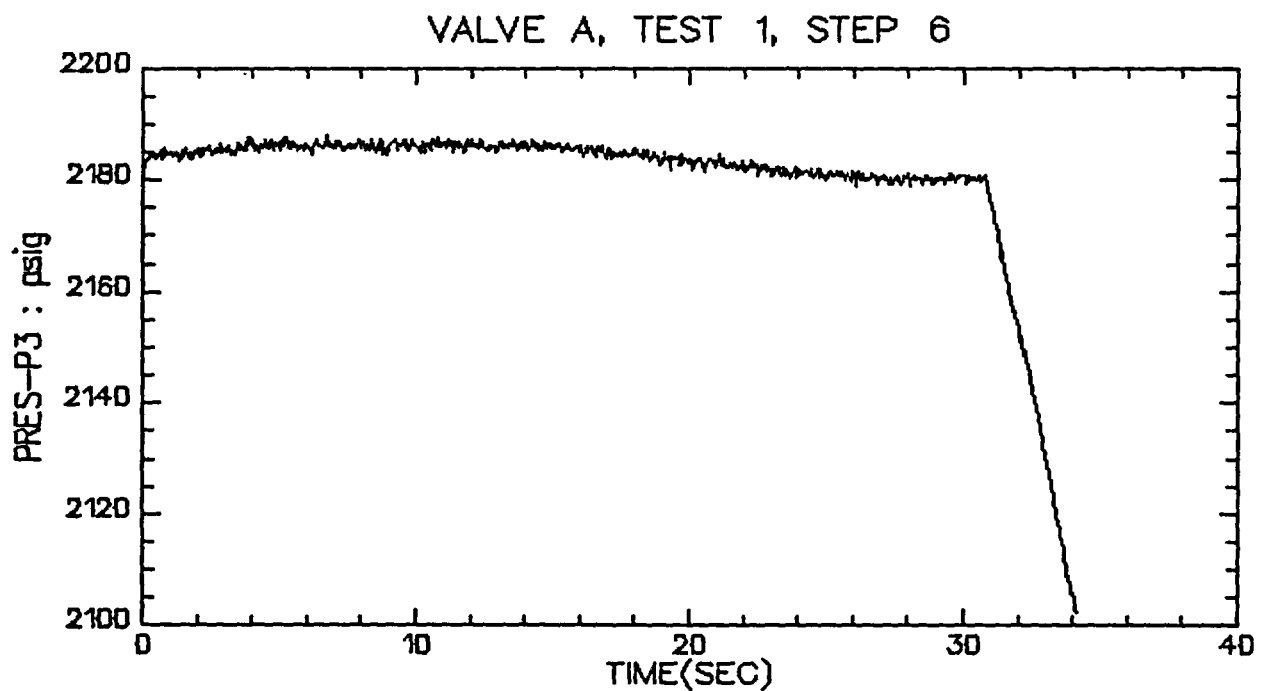
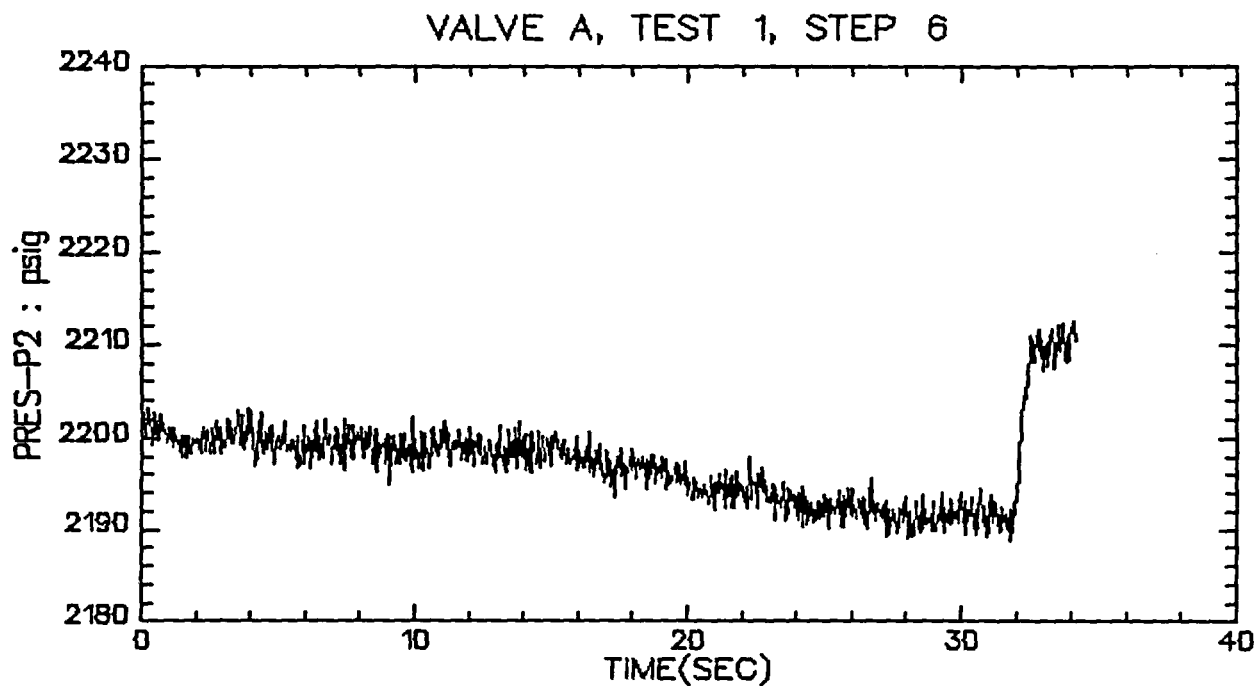

VALVE A, TEST 1, STEP 6

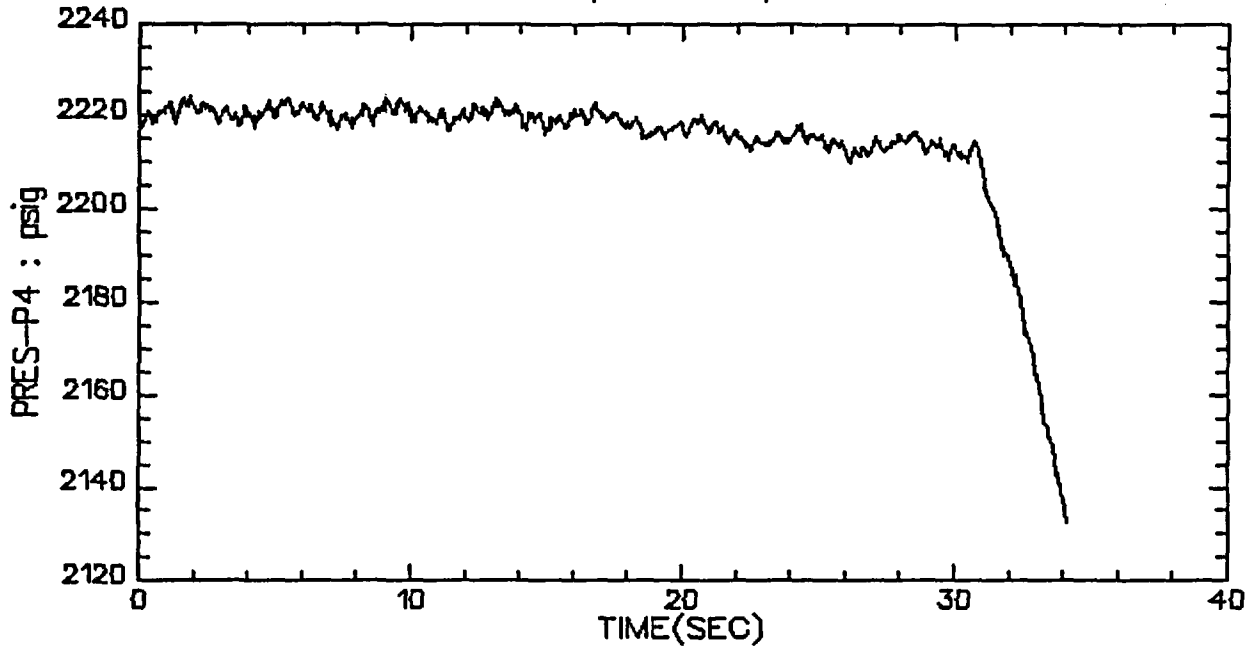

VALVE A, TEST 1, STEP 6

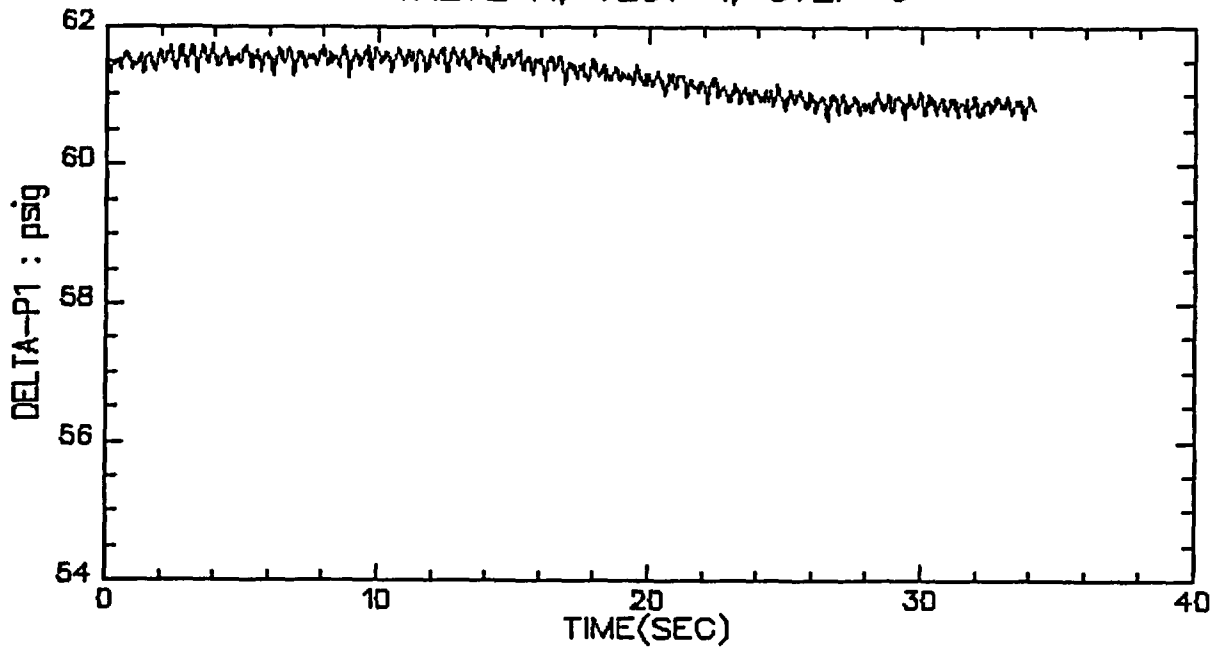

VALVE A, TEST 1, STEP 6

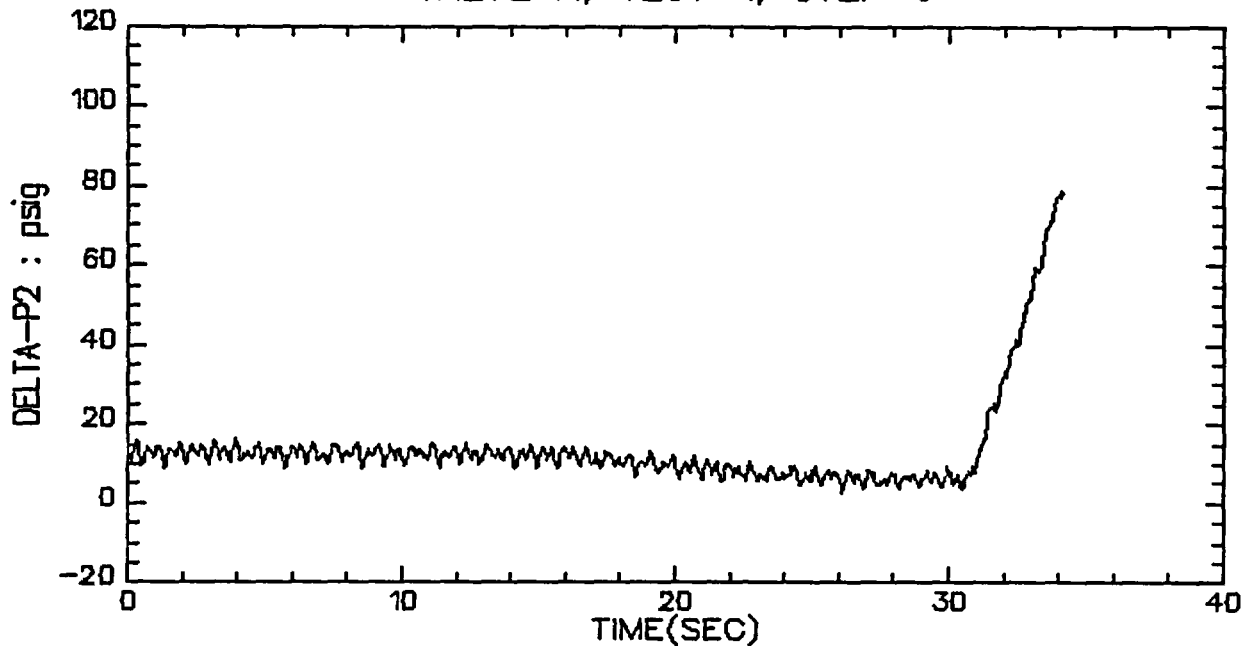

VALVE A, TEST 1, STEP 6

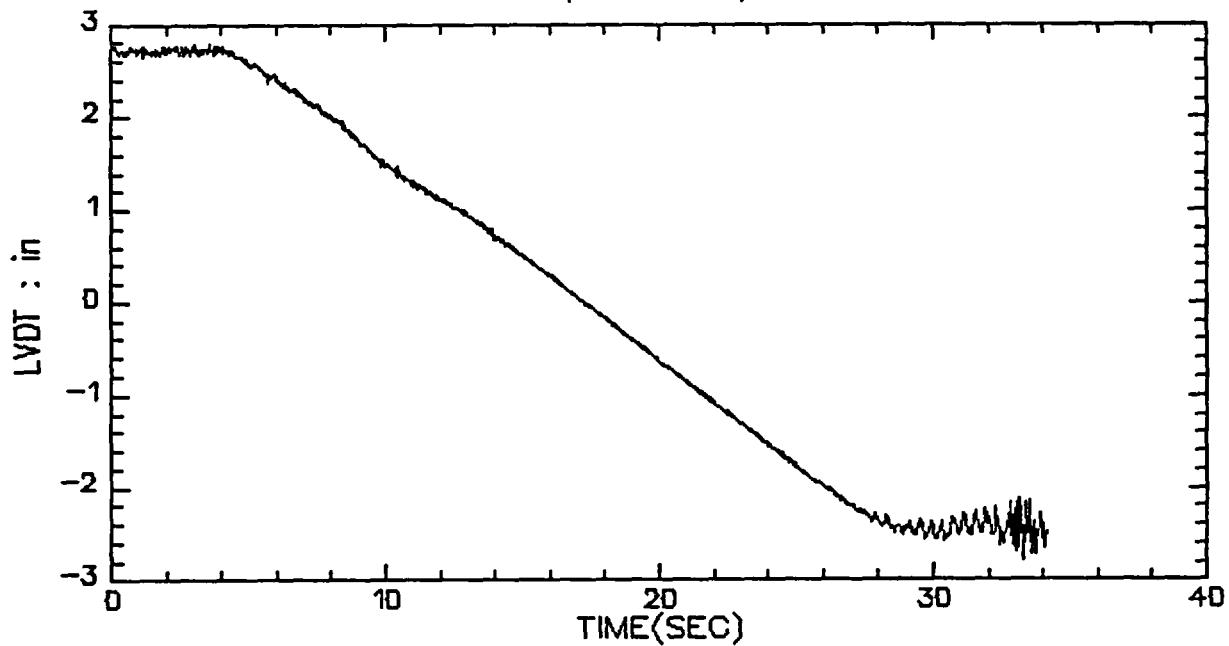

VALVE A, TEST 1, STEP 6

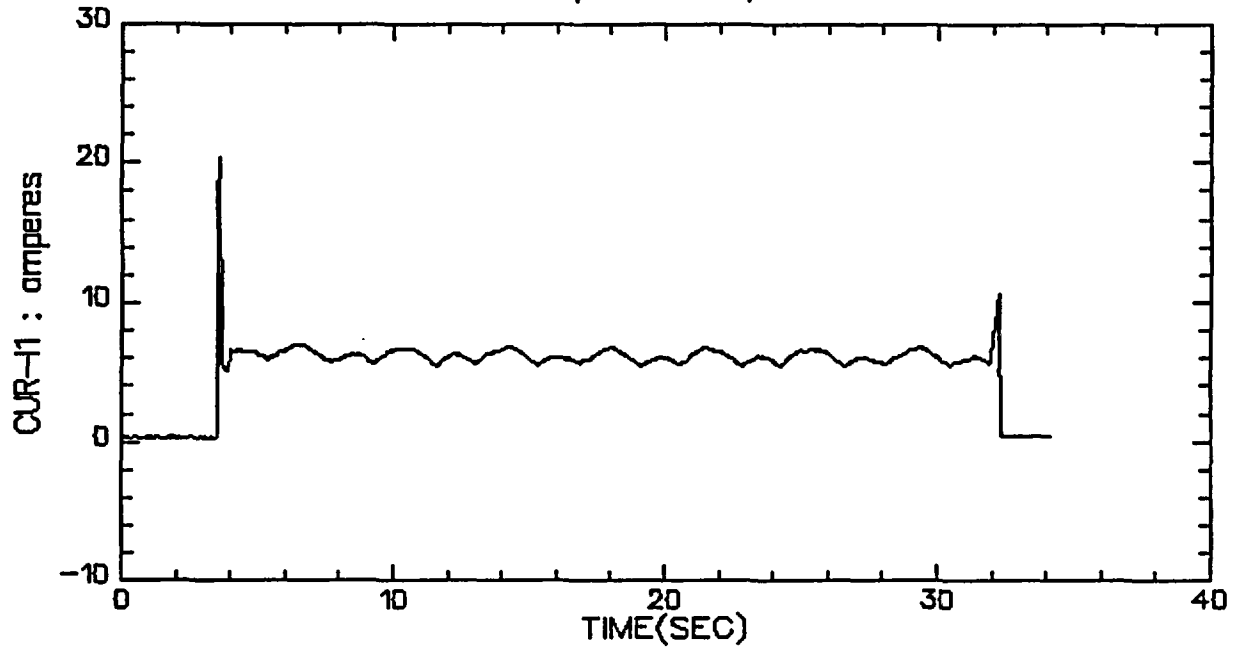

VALVE A, TEST 1, STEP 6

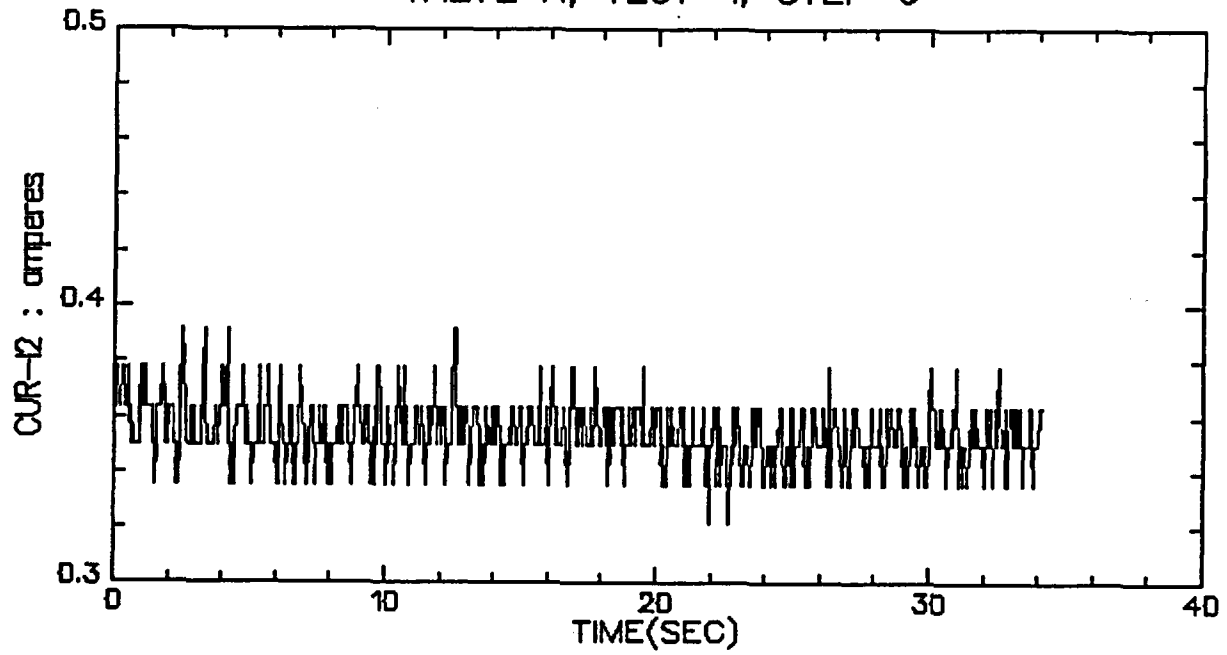

VALVE A, TEST 1, STEP 6

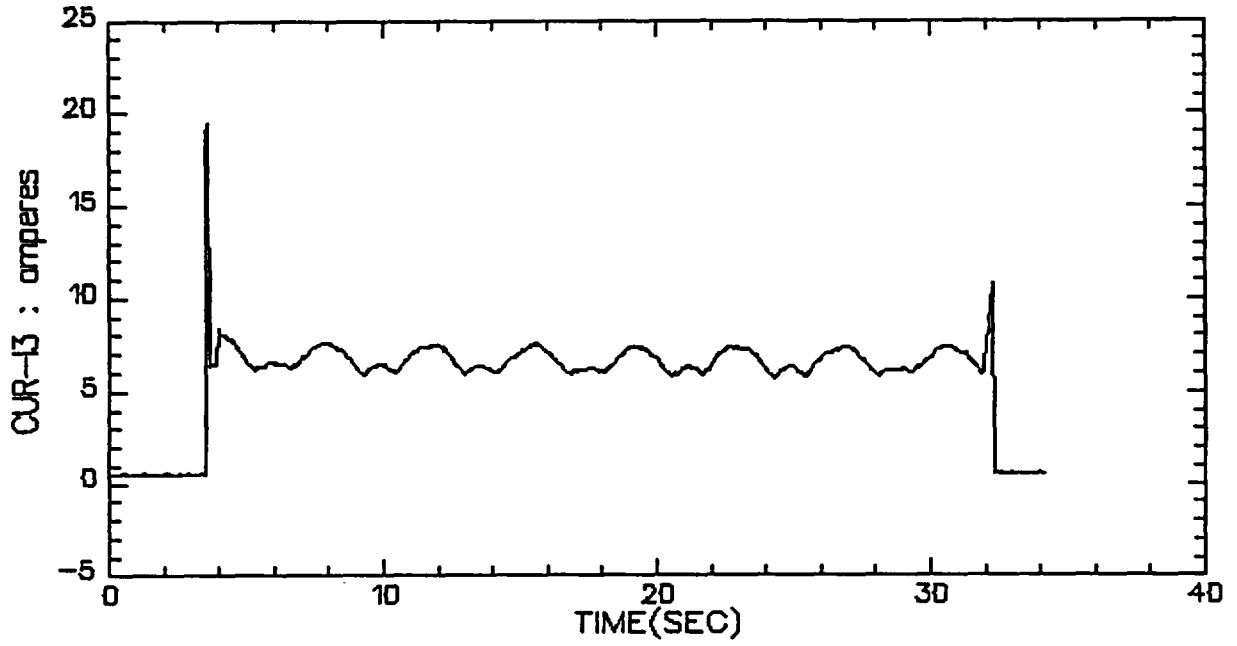

VALVE A, TEST 1, STEP 6

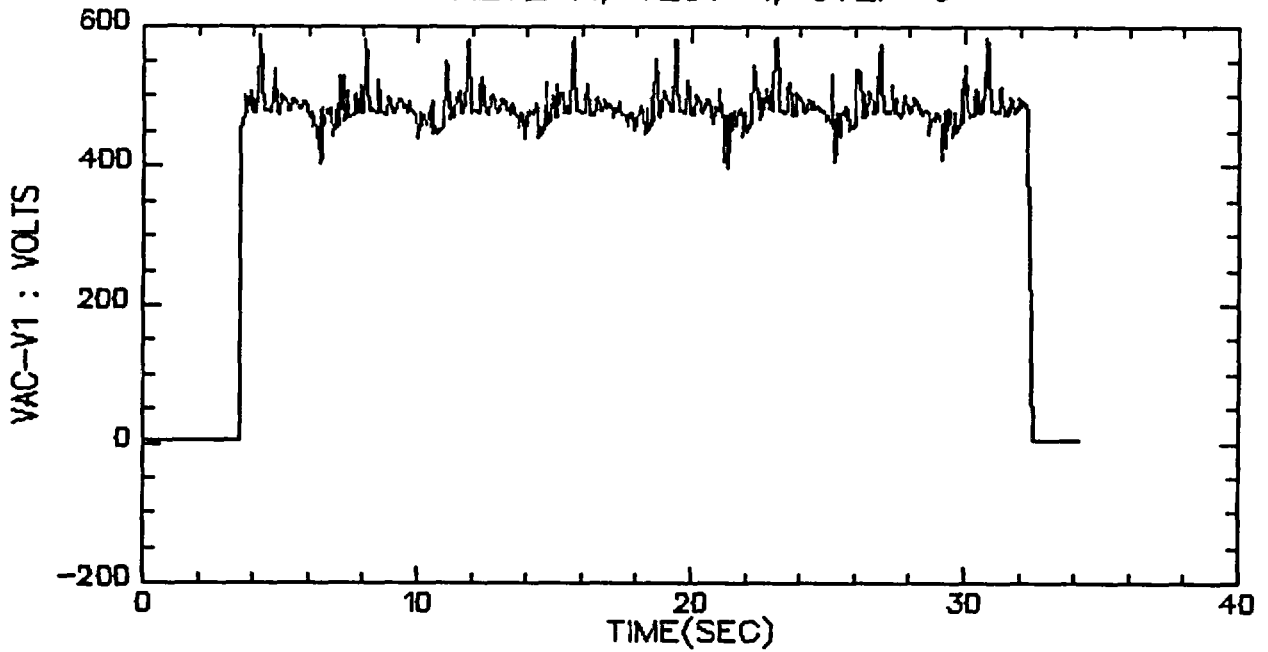

VALVE A, TEST 1, STEP 6

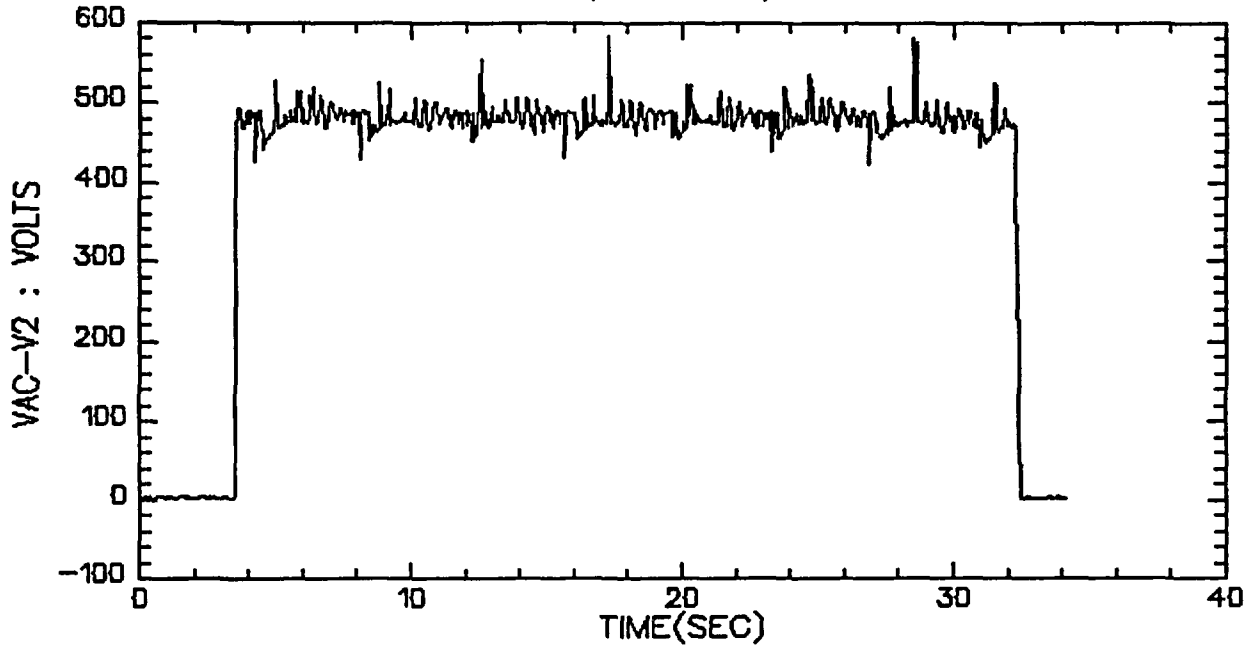

VALVE A, TEST 1, STEP 6

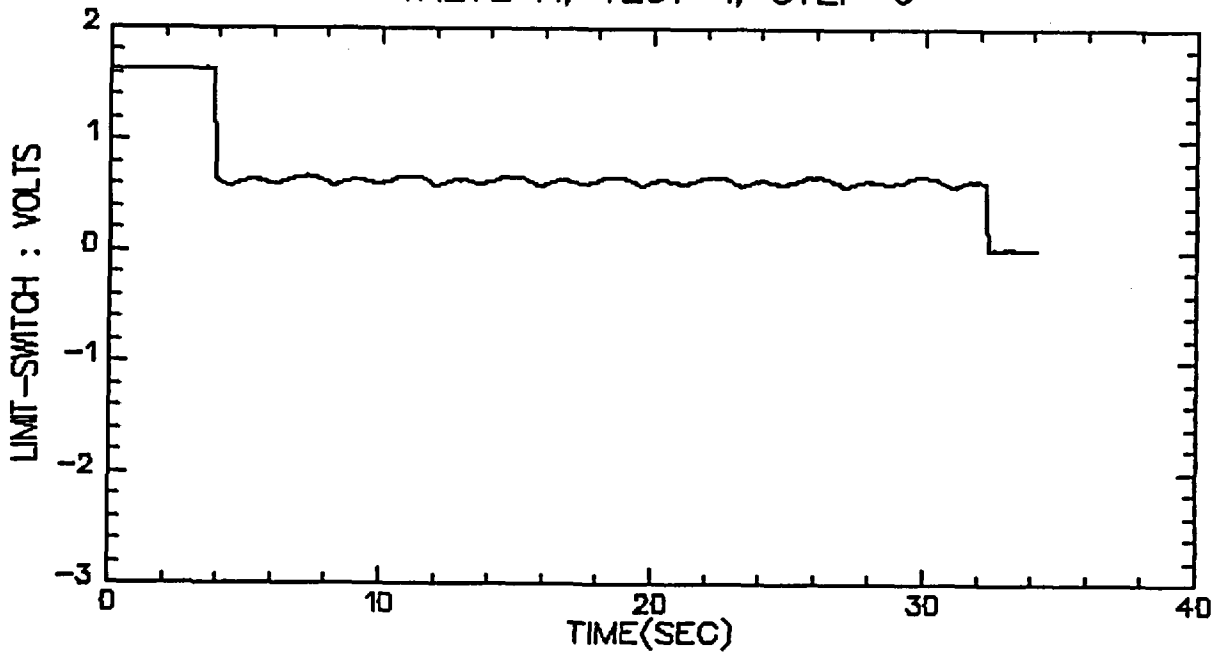

VALVE A, TEST 1, STEP 6

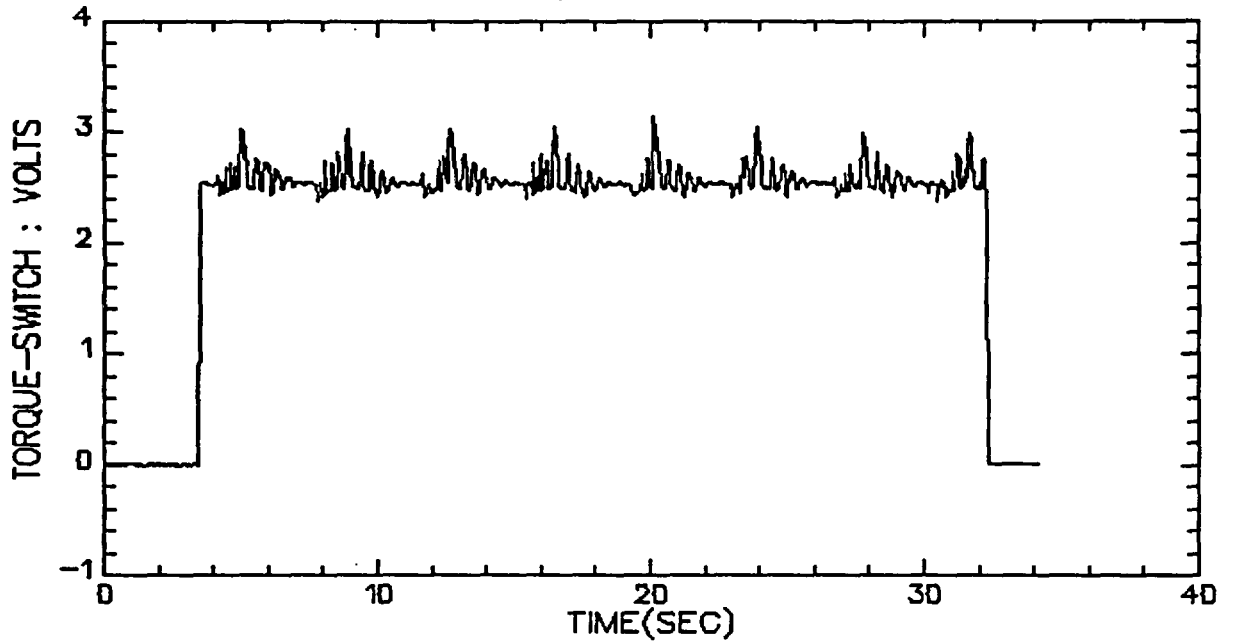

VALVE A, TEST 1, STEP 6

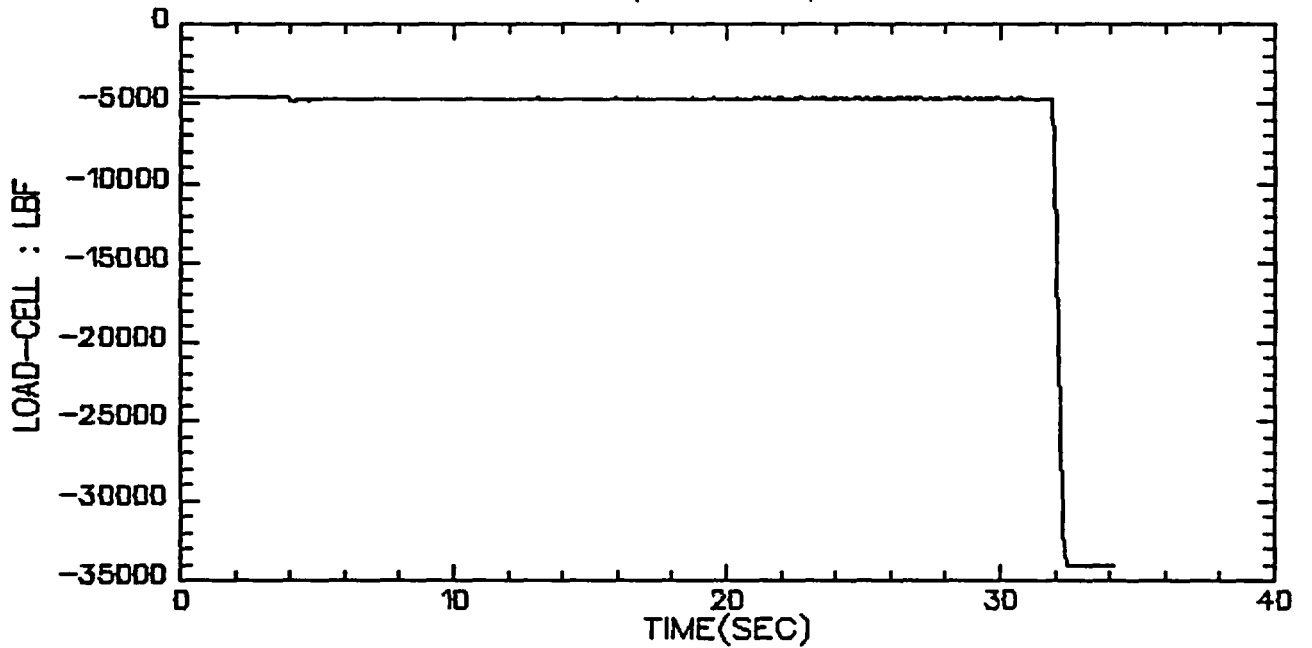

VALVE A, TEST 1, STEP 7

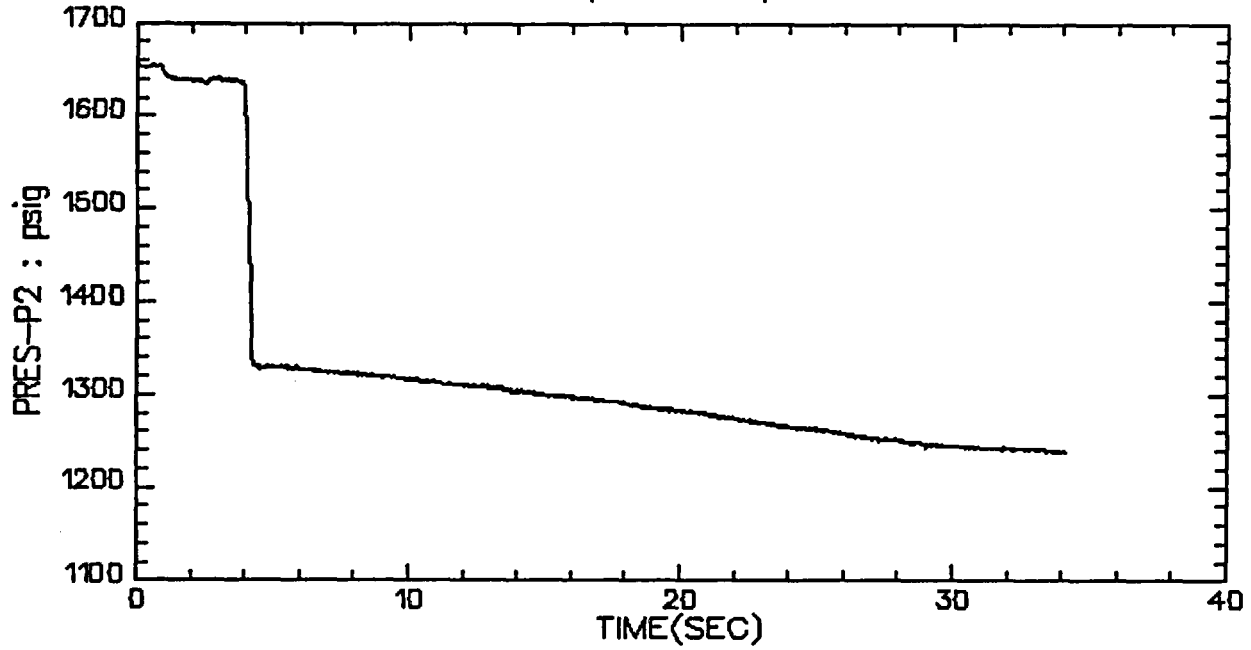

VALVE A, TEST 1, STEP 7

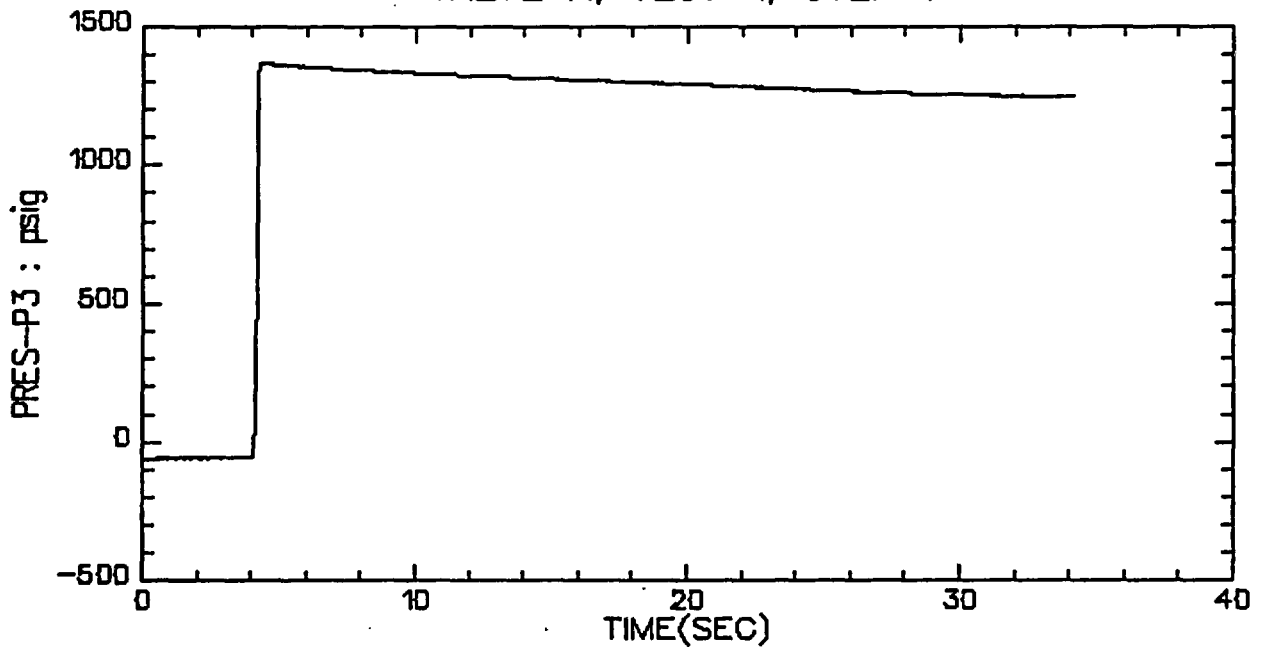

VALVE A, TEST 1, STEP 7

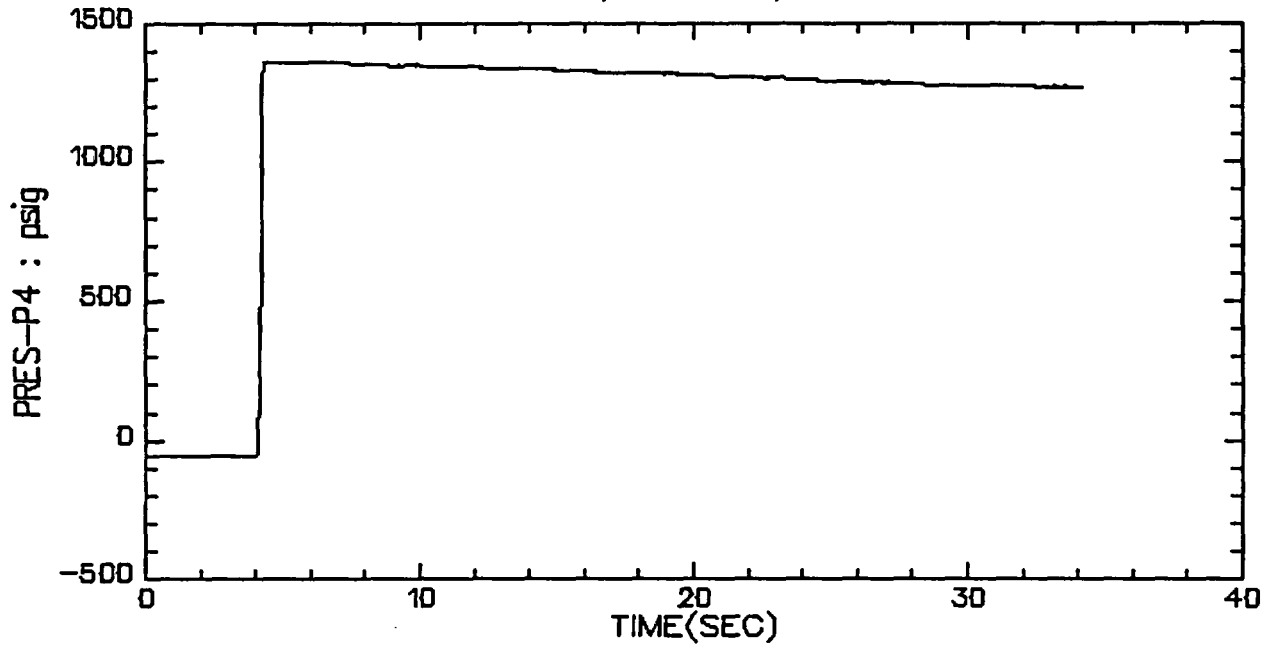

VALVE A, TEST 1, STEP 7

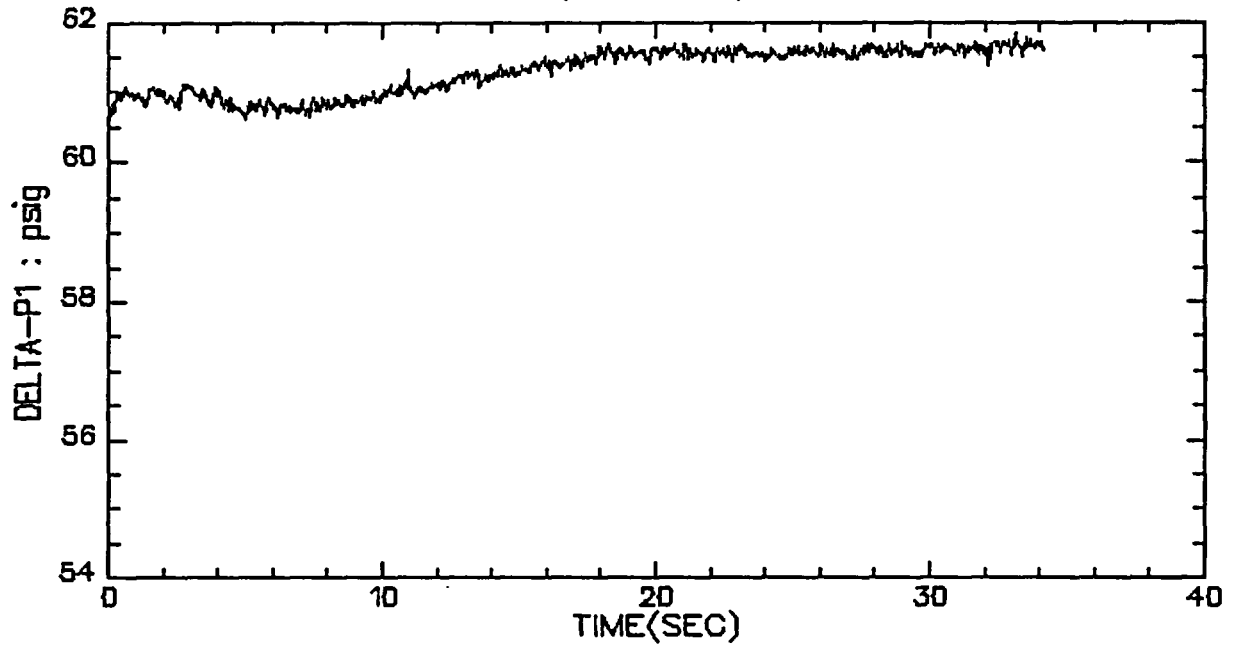

VALVE A, TEST 1, STEP 7

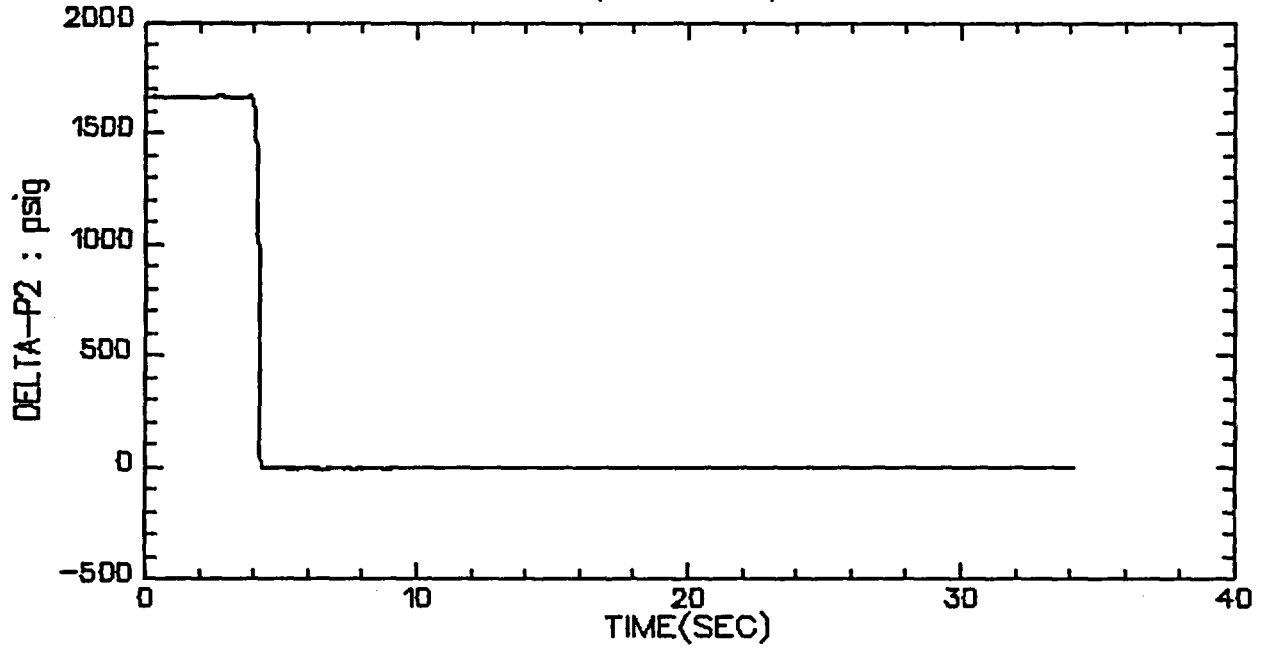

VALVE A, TEST 1, STEP 7

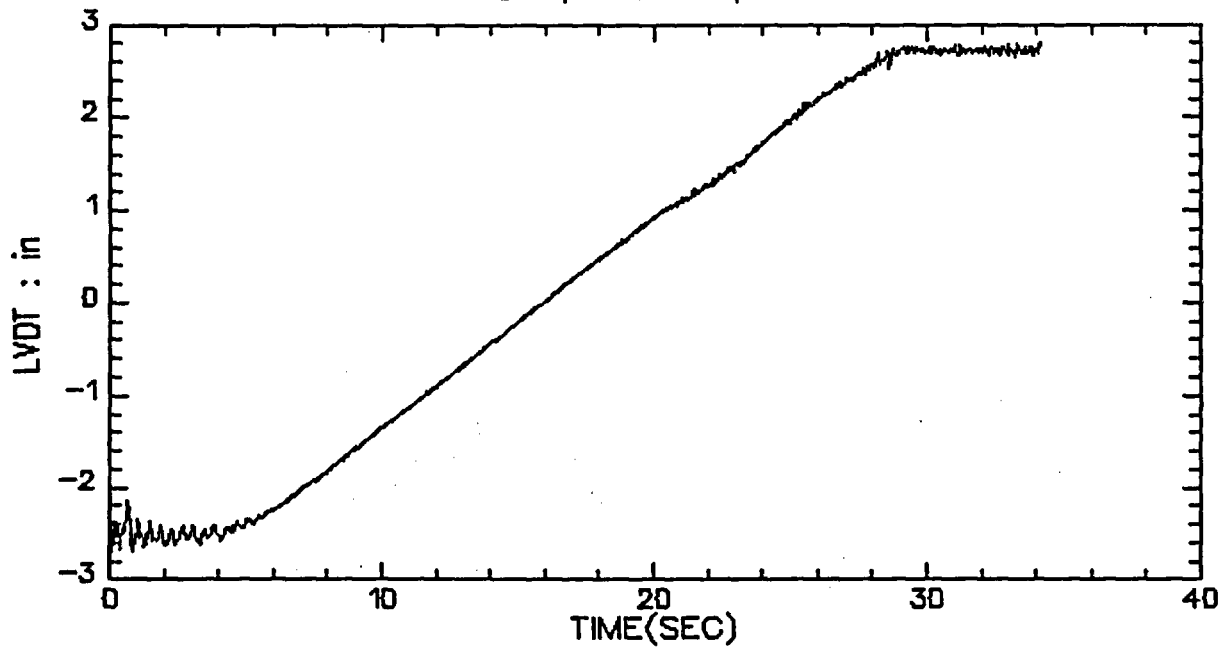

VALVE A, TEST 1, STEP 7

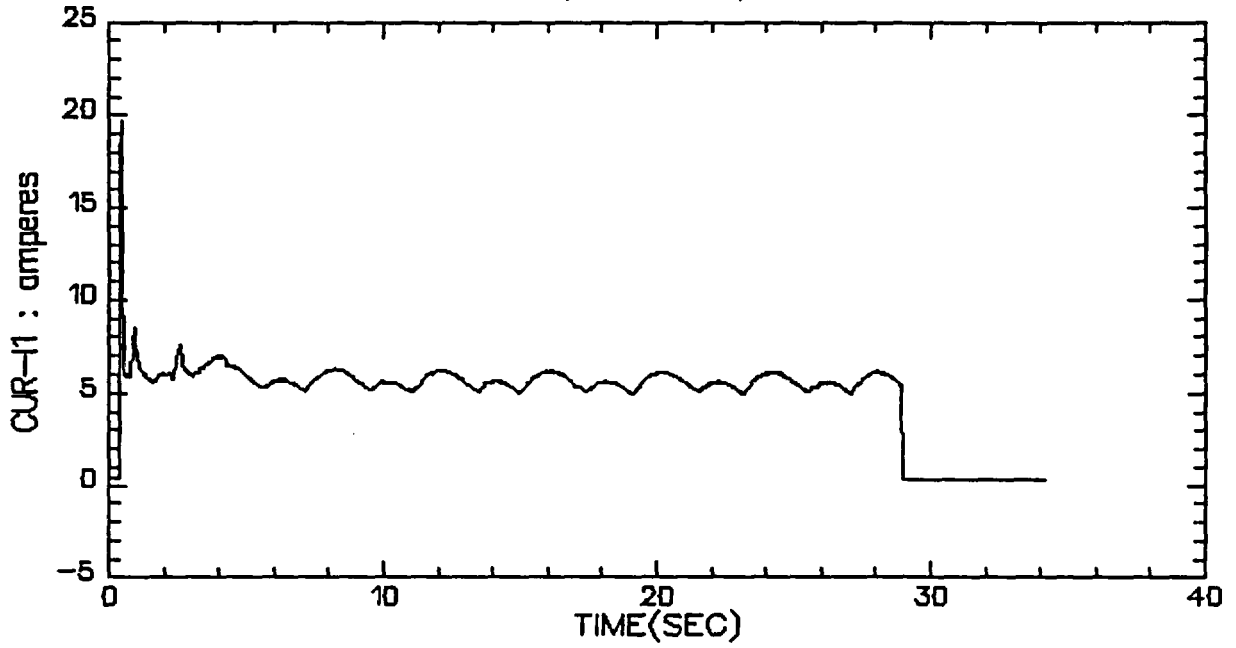

VALVE A, TEST 1, STEP 7

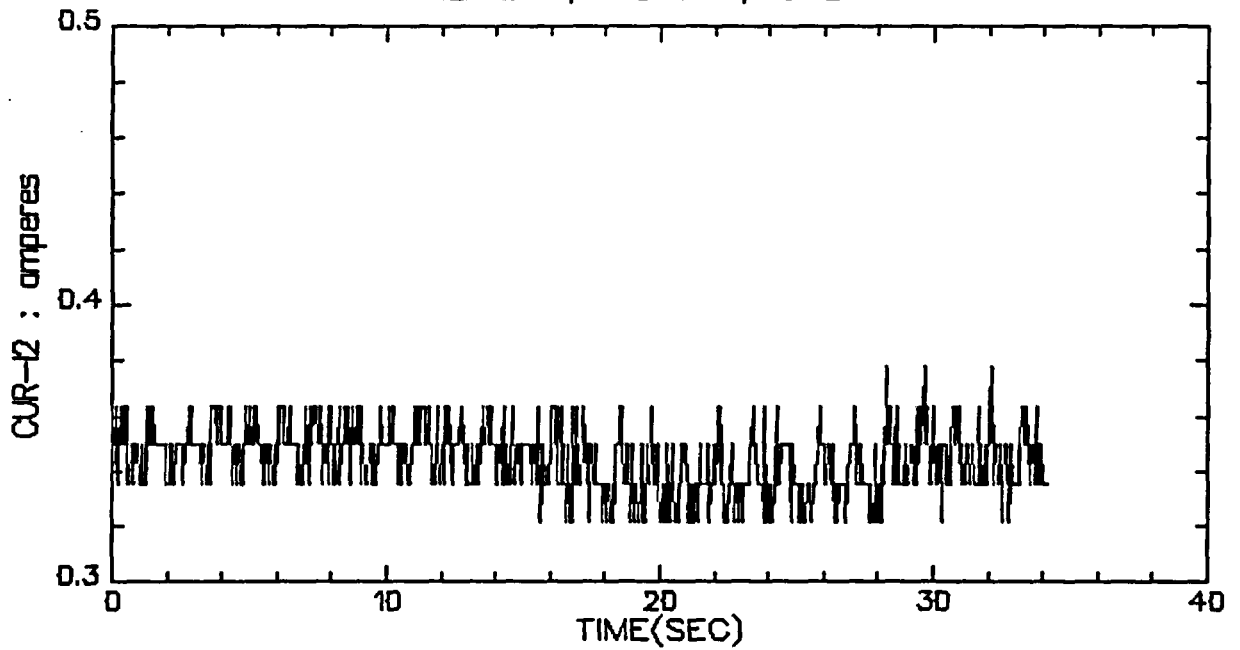

VALVE A, TEST 1, STEP 7

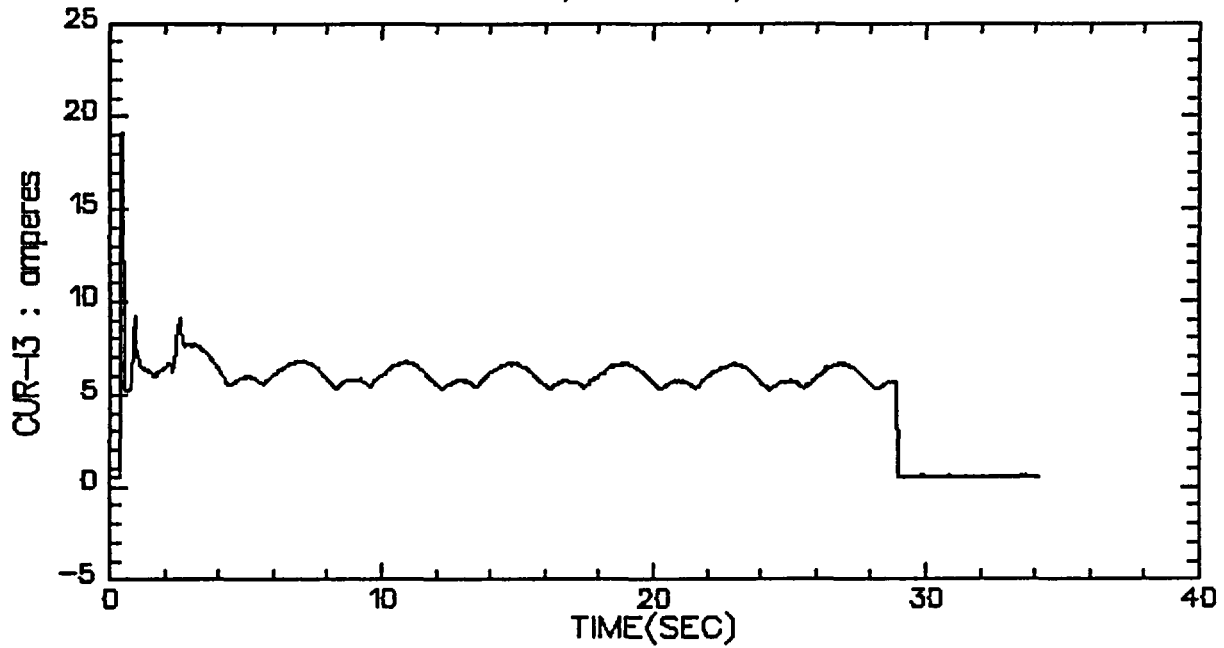

VALVE A, TEST 1, STEP 7

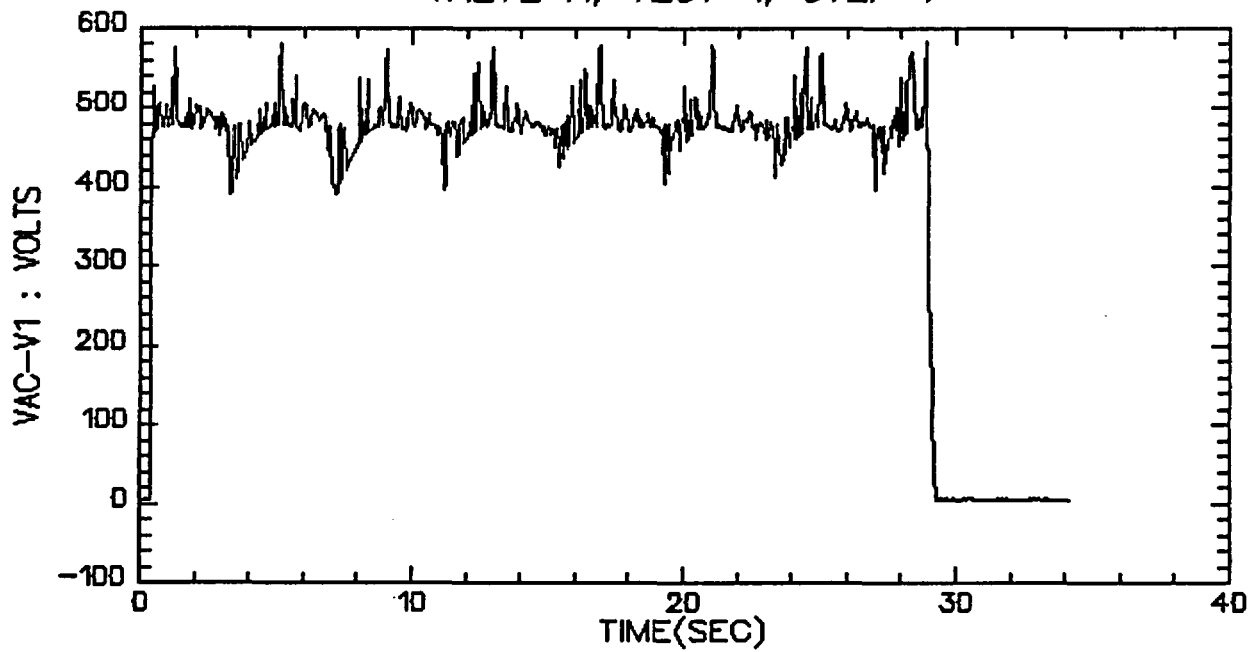

VALVE A, TEST 1, STEP 7

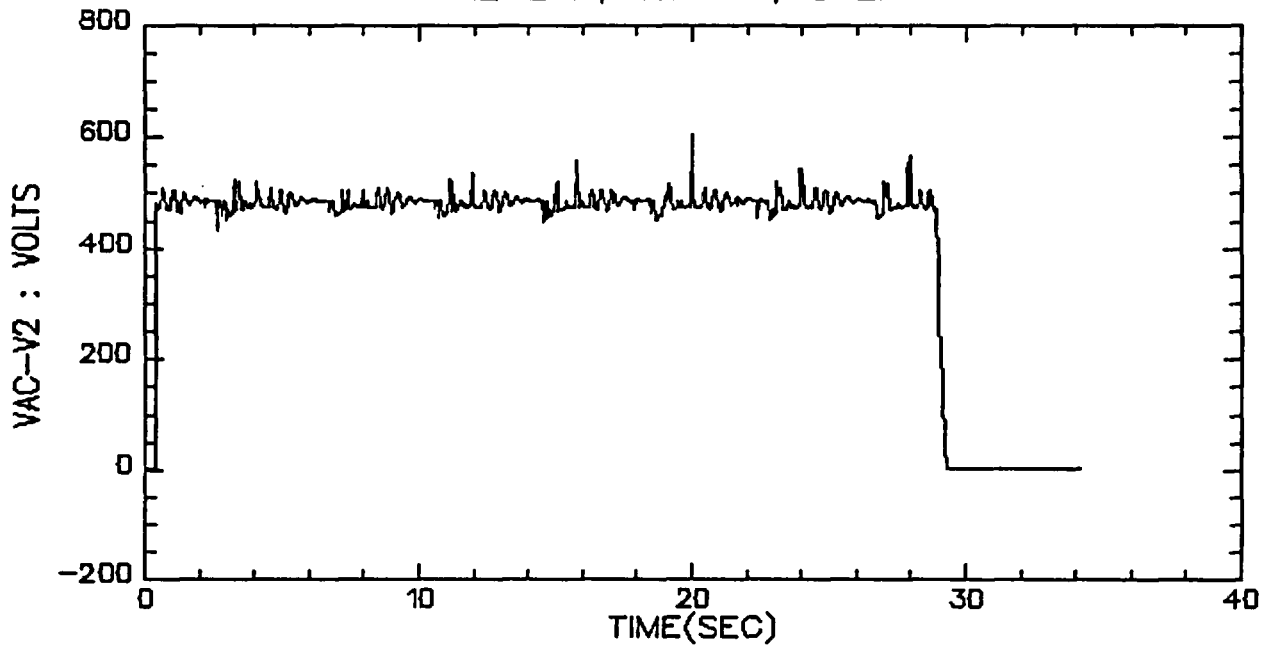

VALVE A, TEST 1, STEP 7

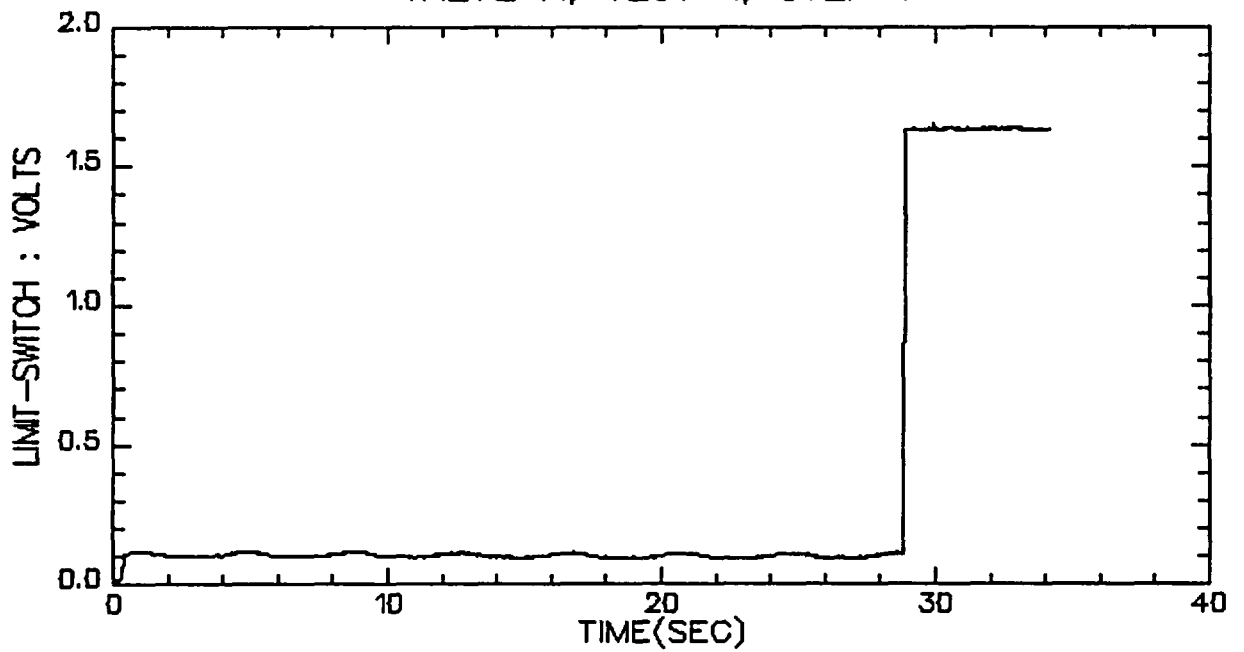

VALVE A, TEST 1, STEP 7

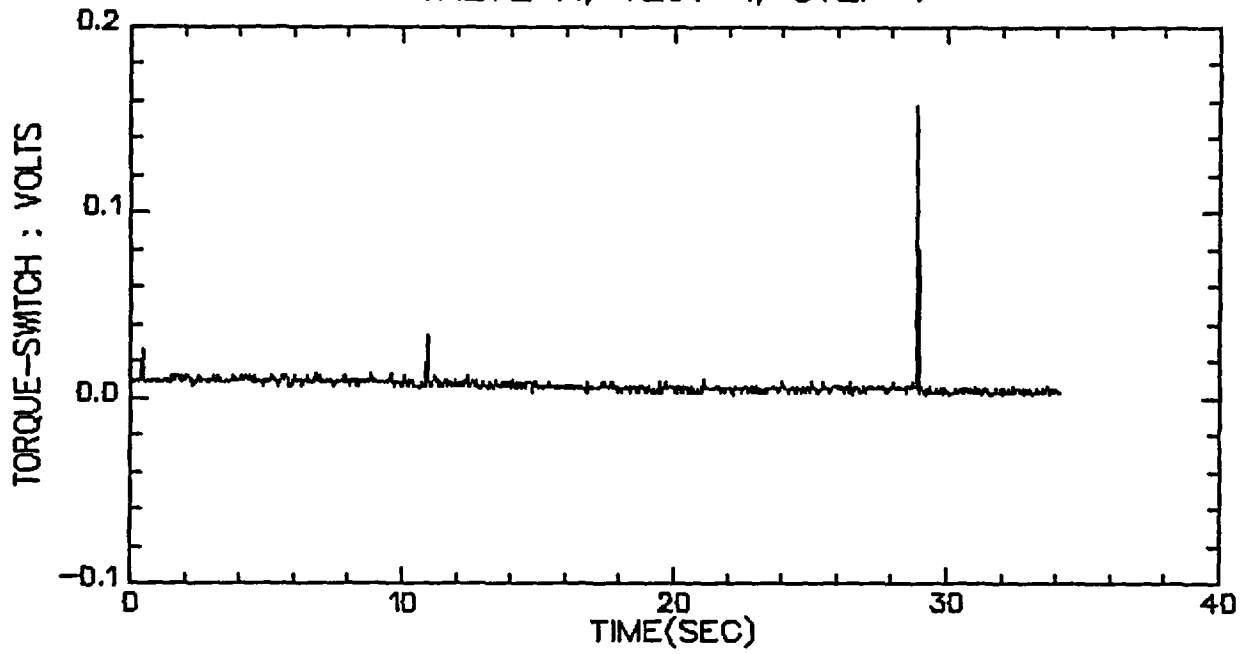

VALVE A, TEST 1, STEP 7

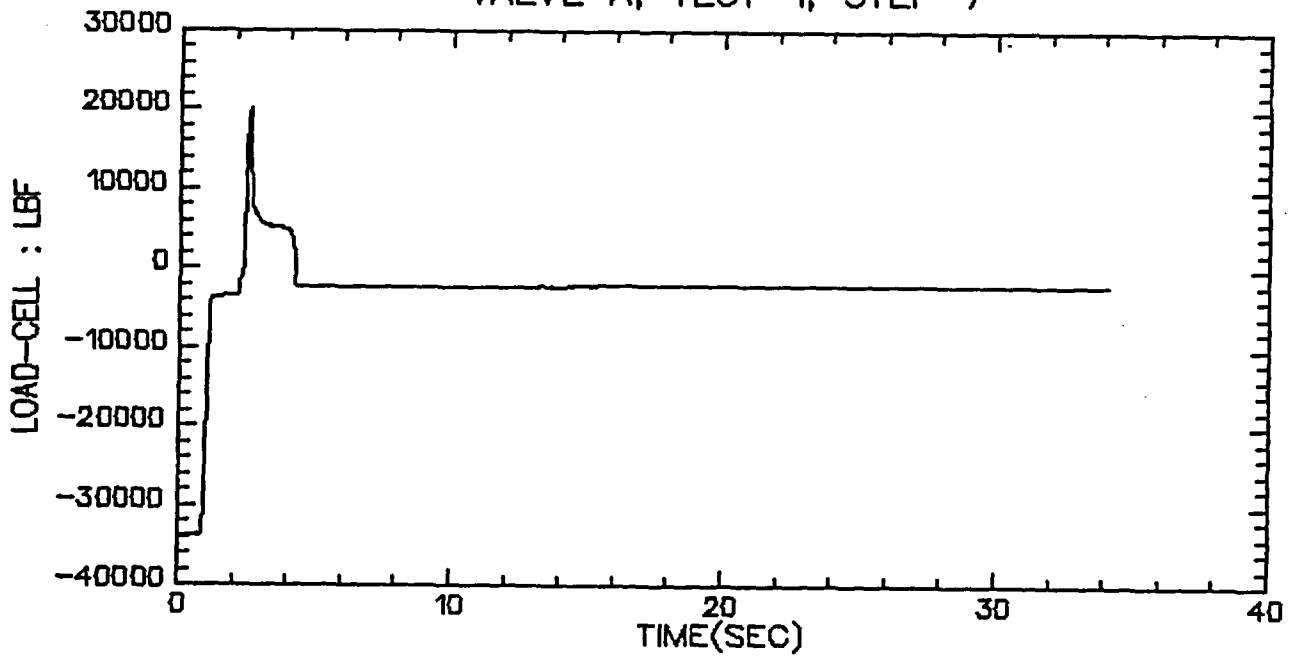

VALVE A, TEST 1, STEP 9

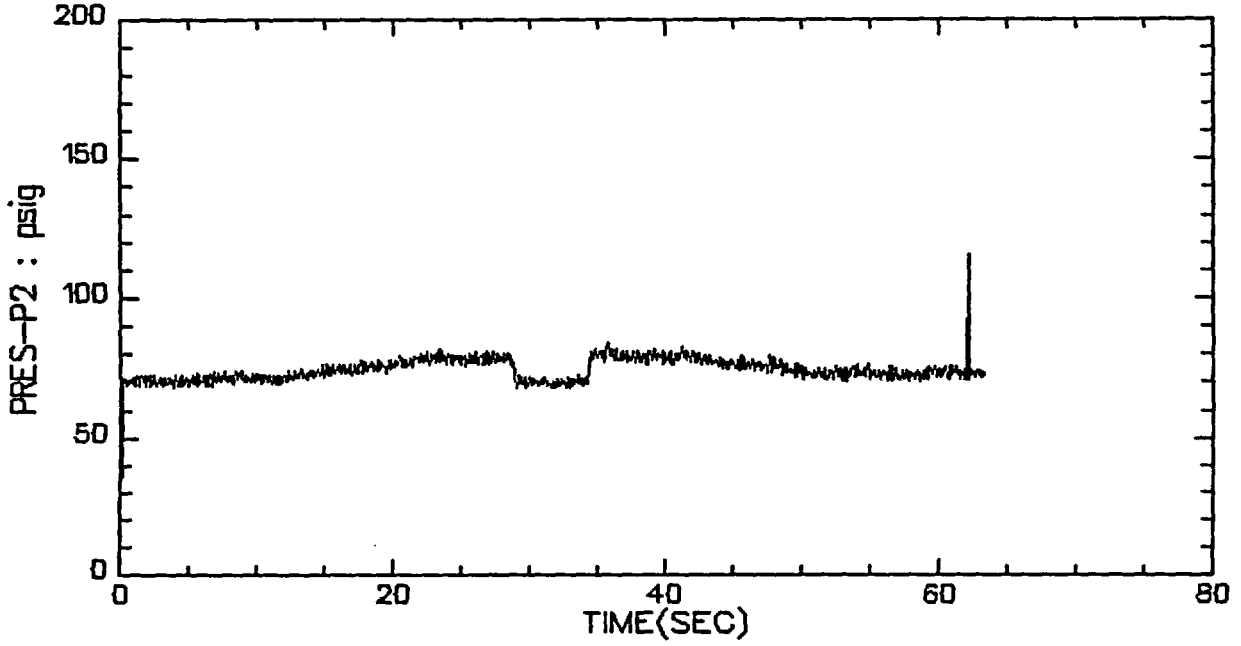

VALVE A, TEST 1, STEP 9

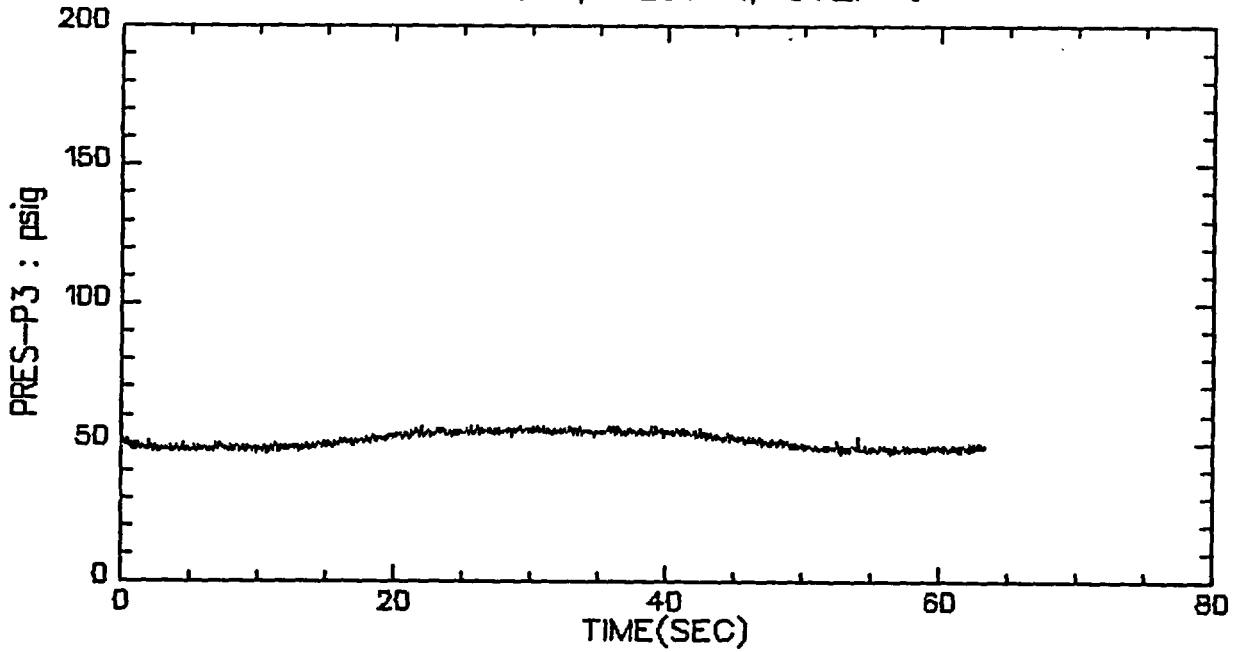

VALVE A, TEST 1, STEP 9

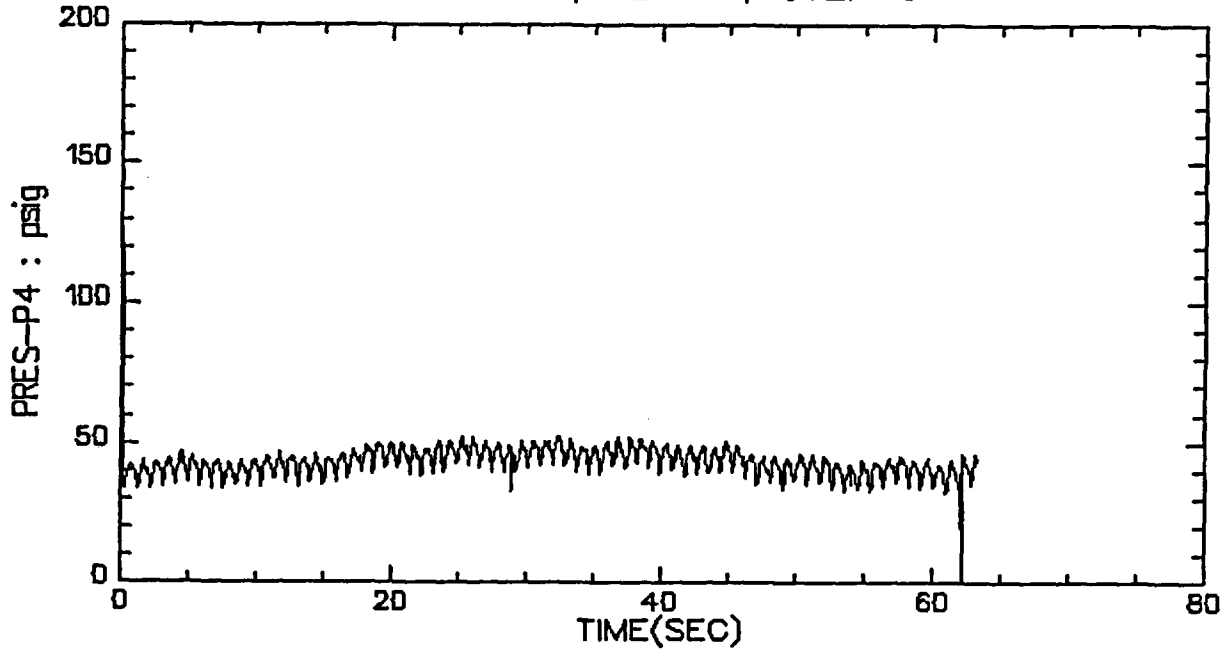

VALVE A, TEST 1, STEP 9

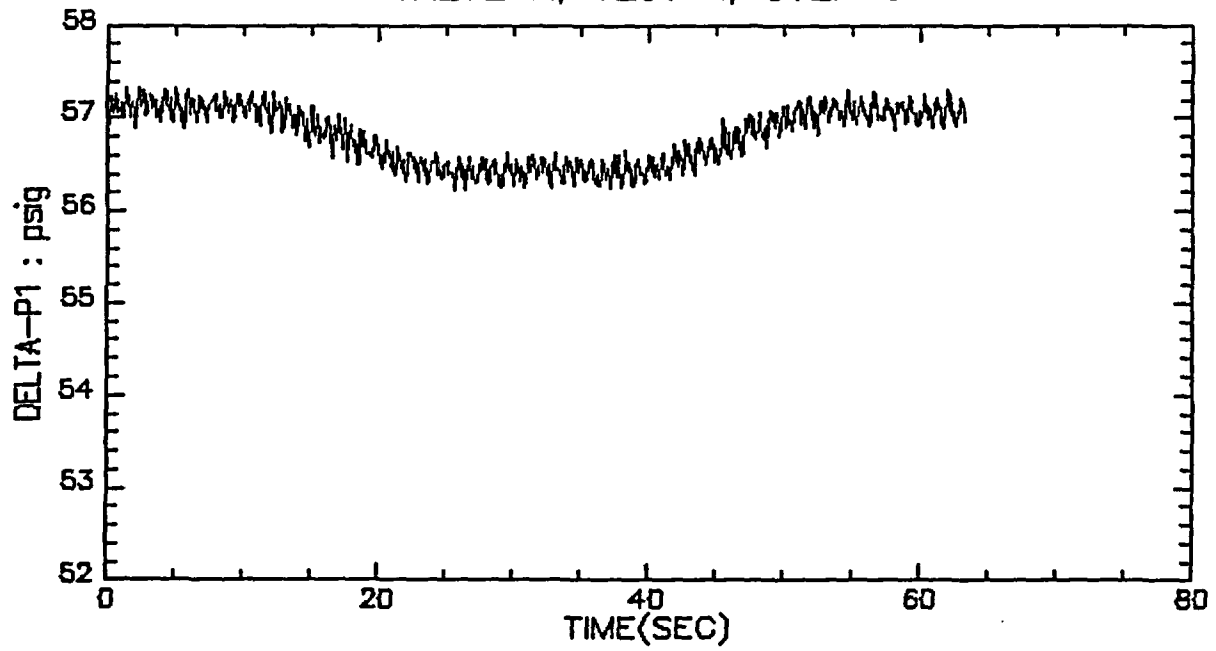

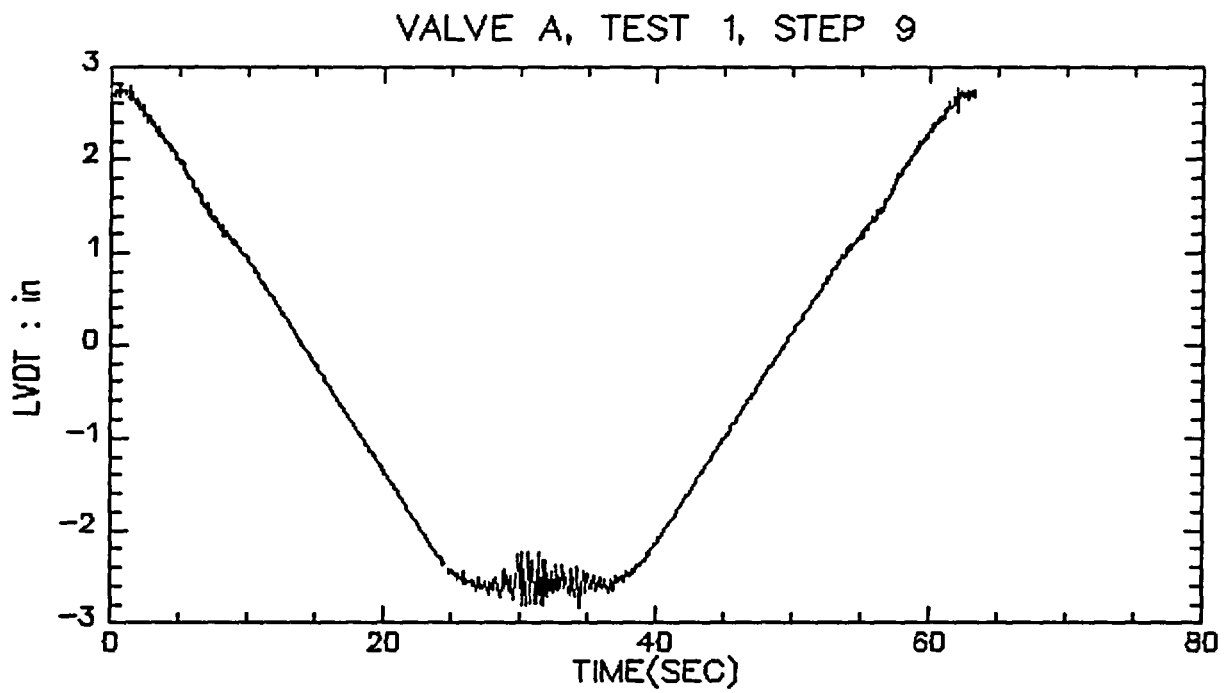
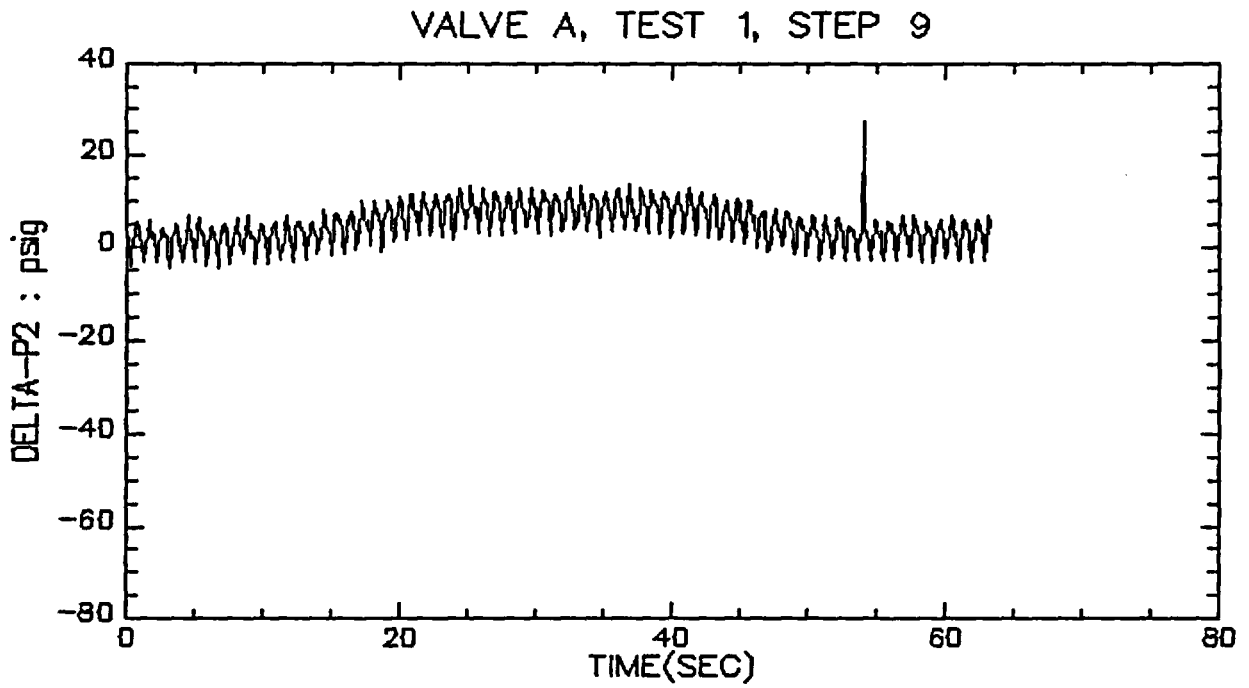

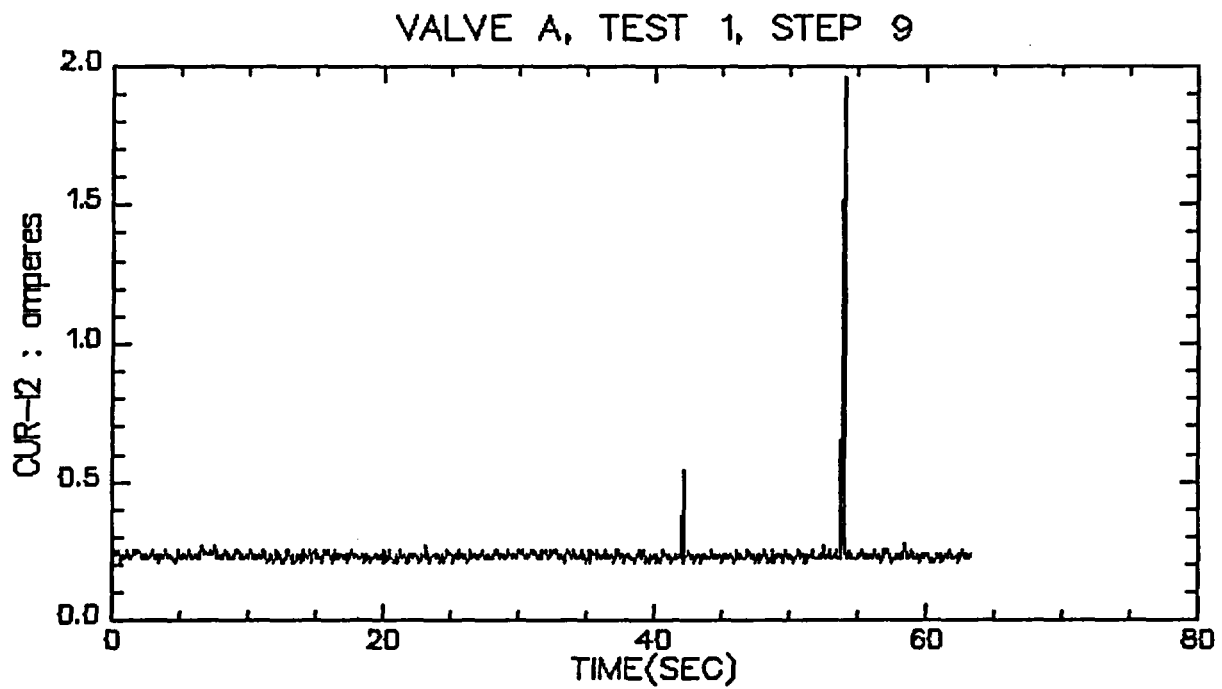
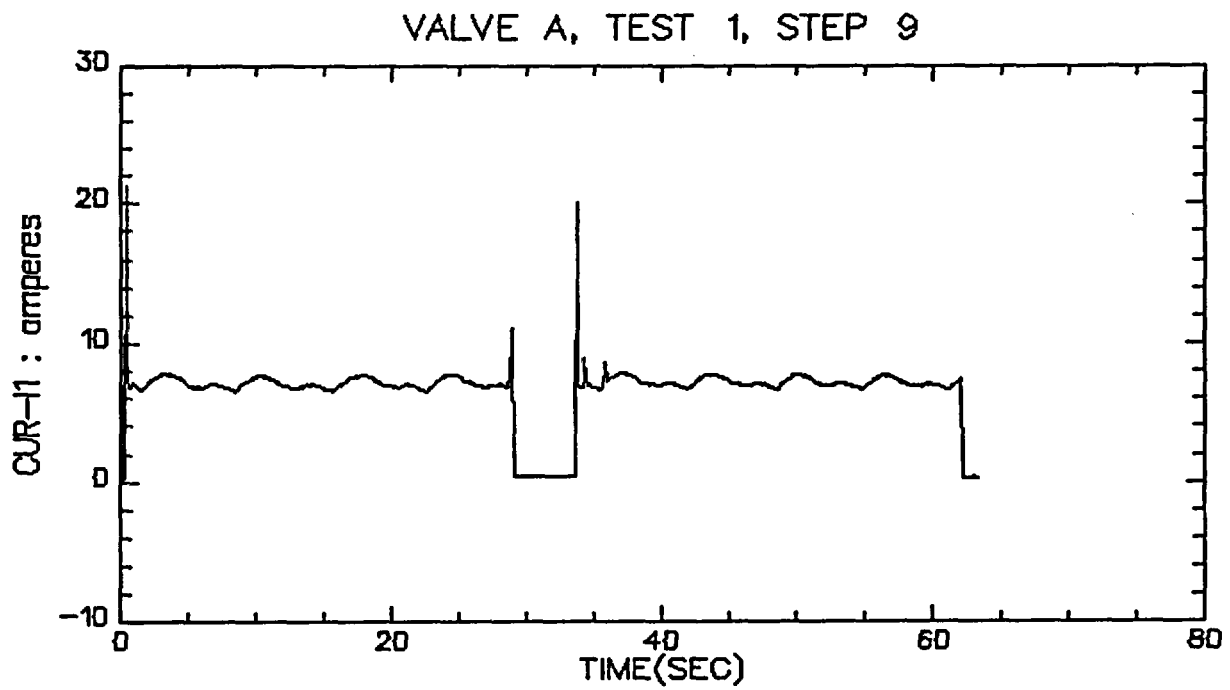

VALVE A, TEST 1, STEP 9

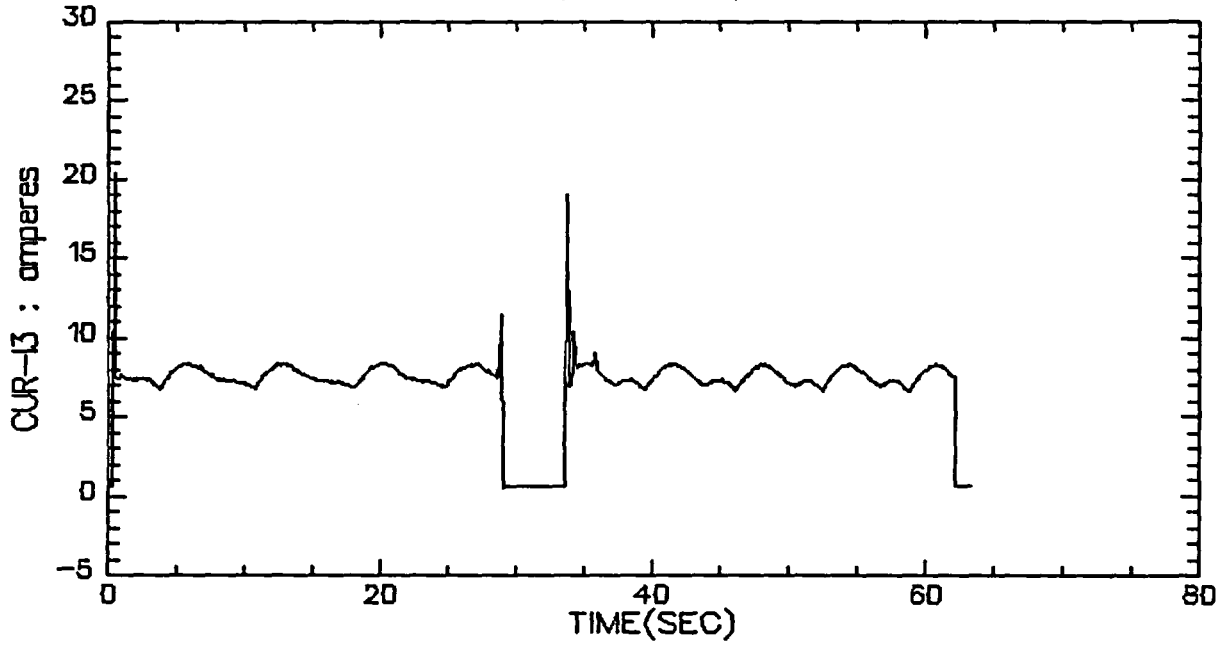

VALVE A, TEST 1, STEP 9

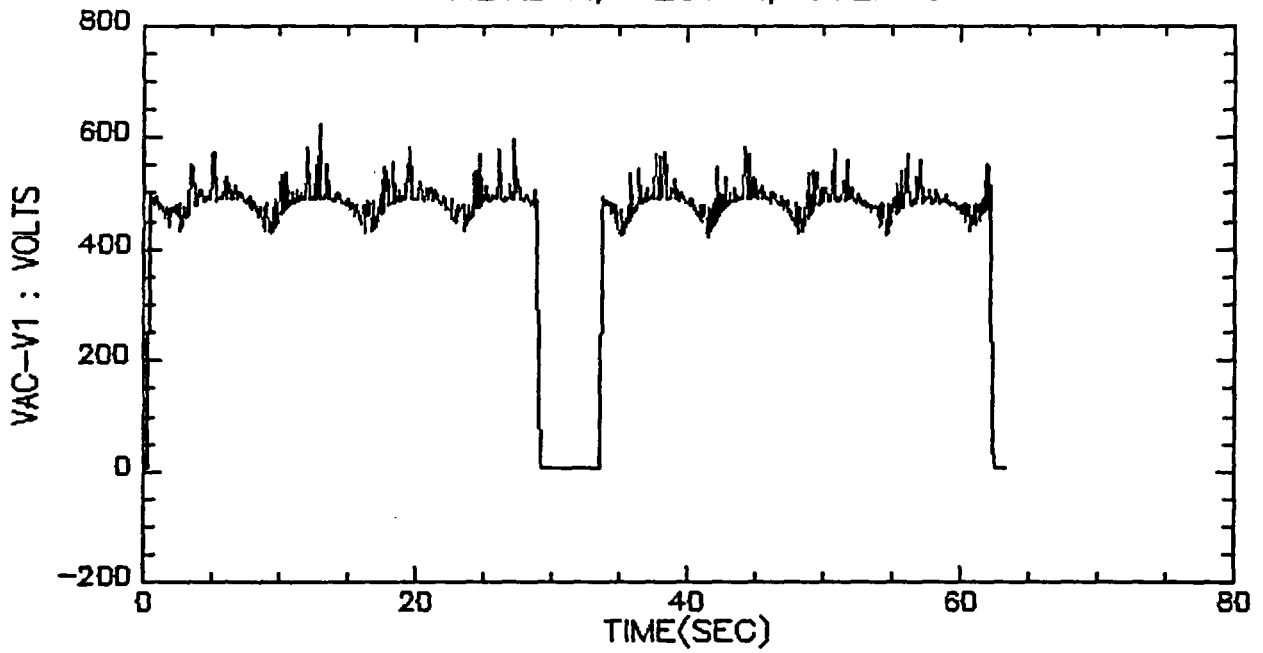

VALVE A, TEST 1, STEP 9

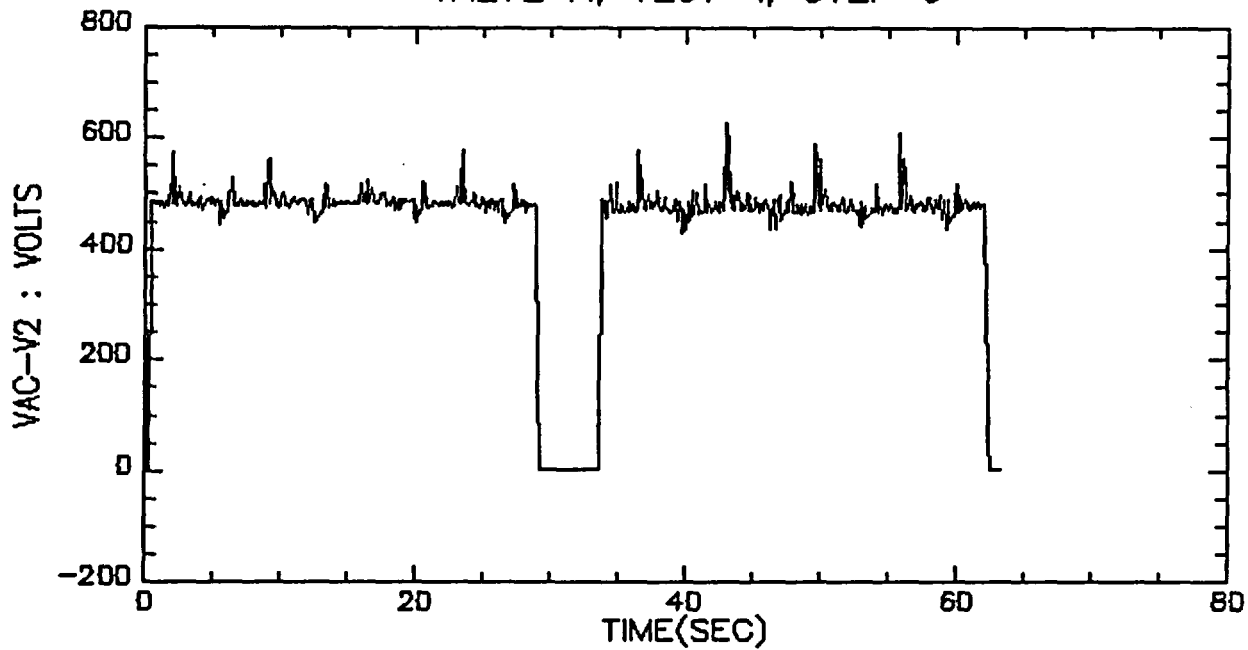

VALVE A, TEST 1, STEP 9

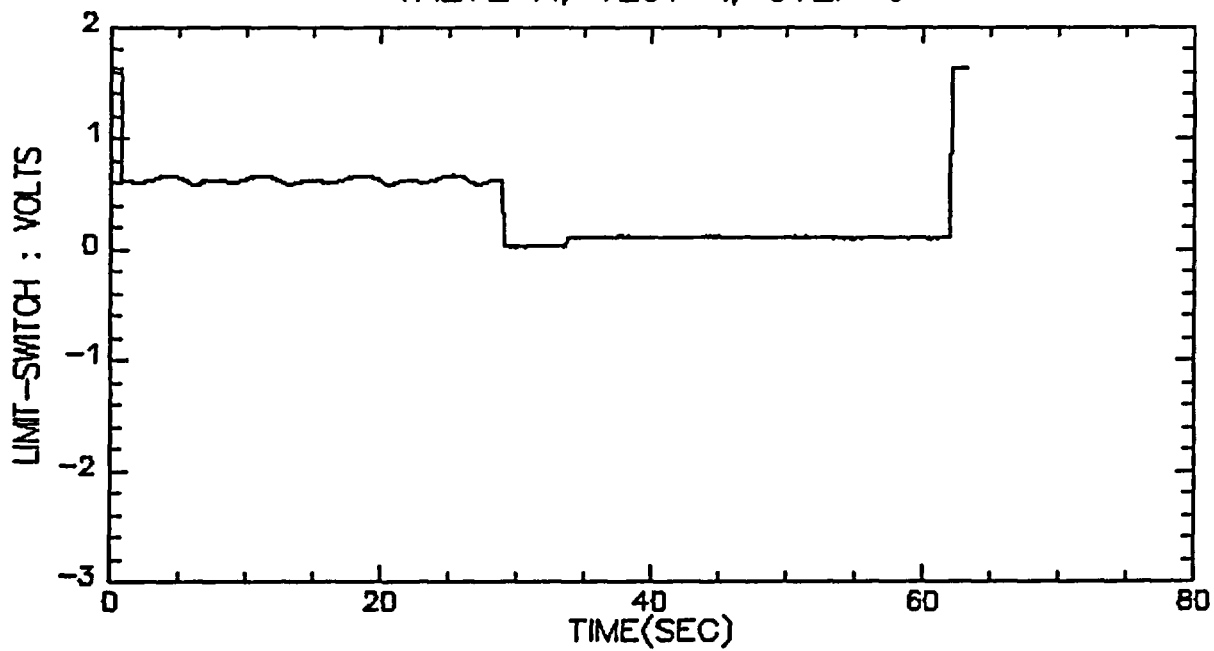

VALVE A, TEST 1, STEP 9

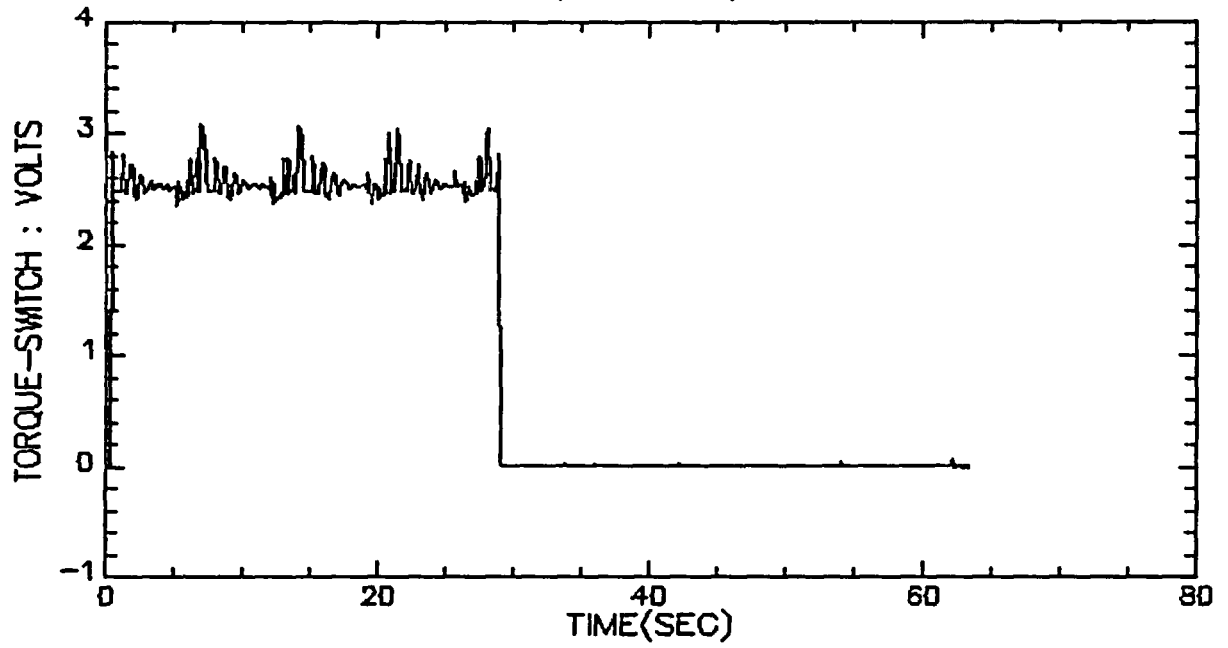

VALVE A, TEST 1, STEP 9

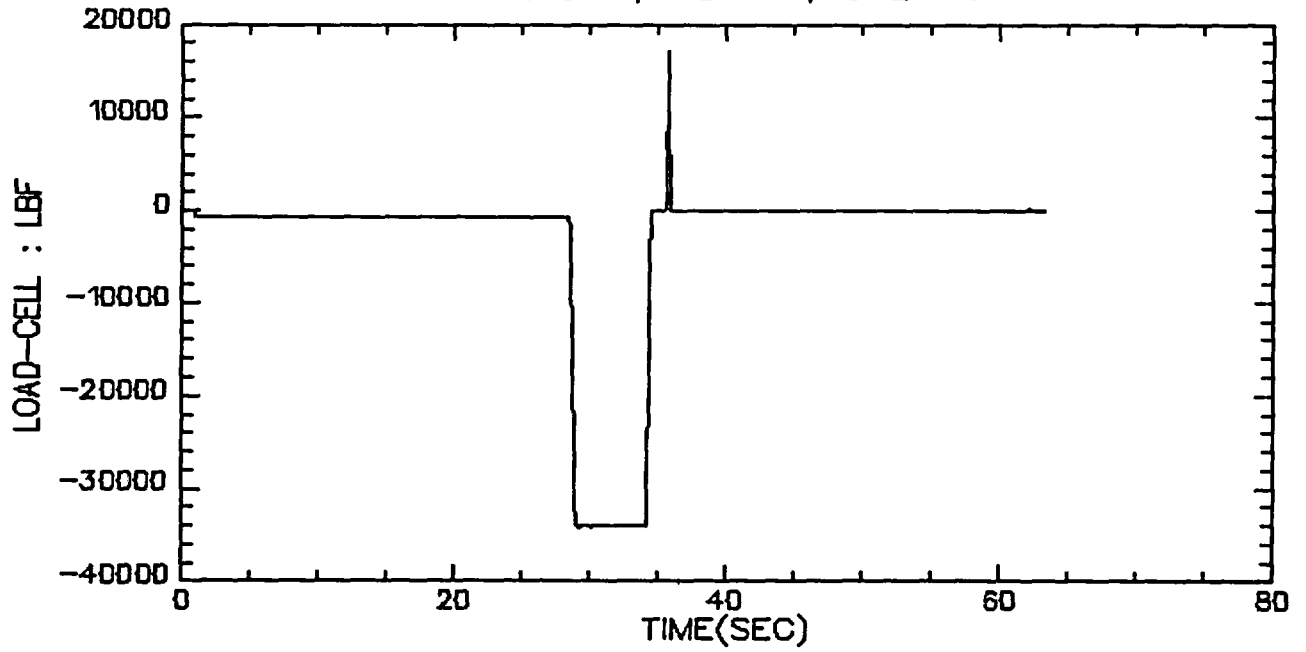

VALVE A, TEST 1, STEP 12

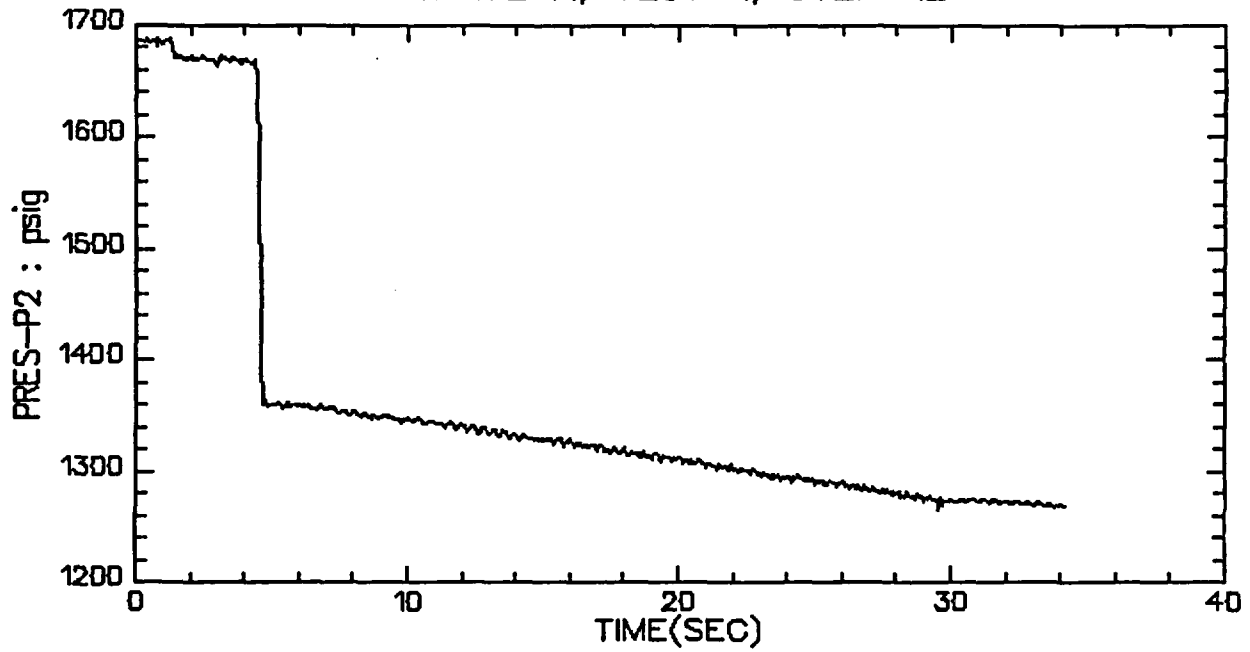

VALVE A, TEST 1, STEP 12

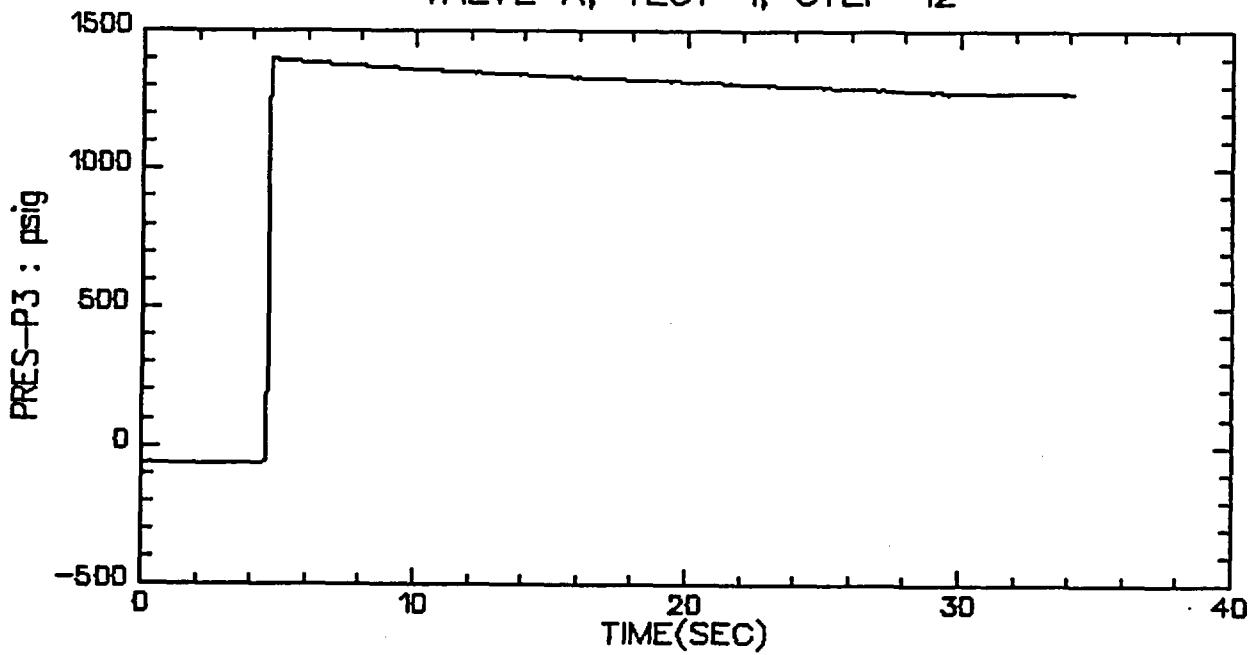

VALVE A, TEST 1, STEP 12

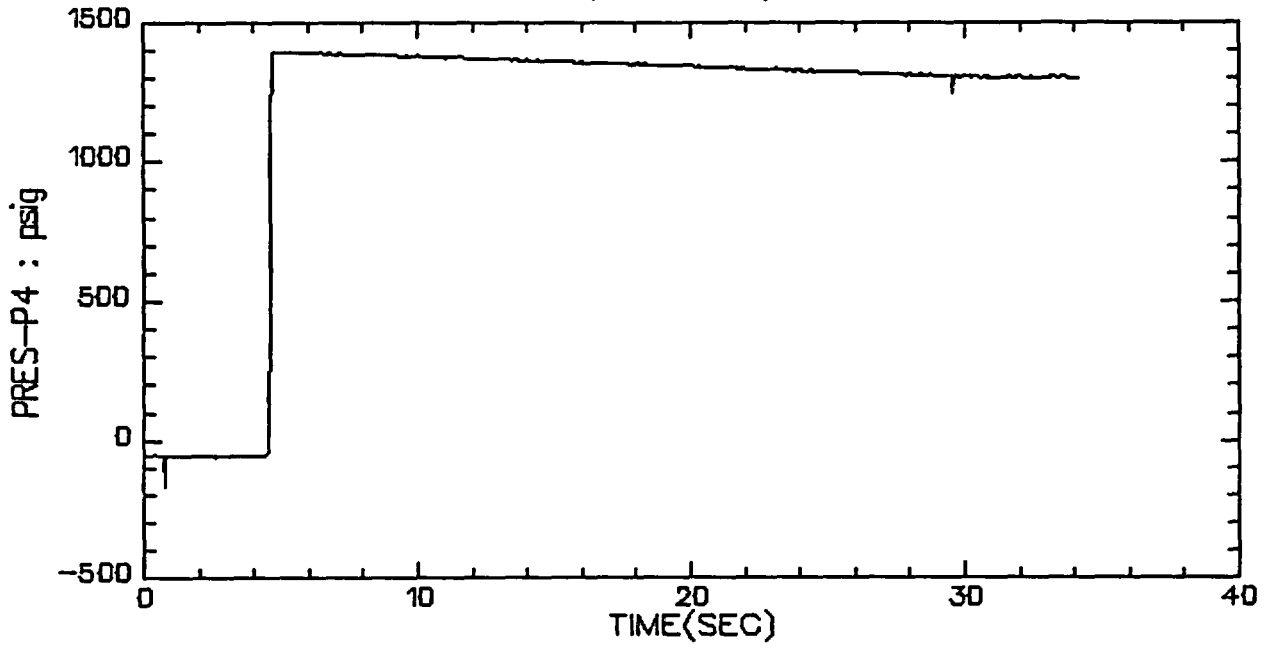

VALVE A, TEST 1, STEP 12

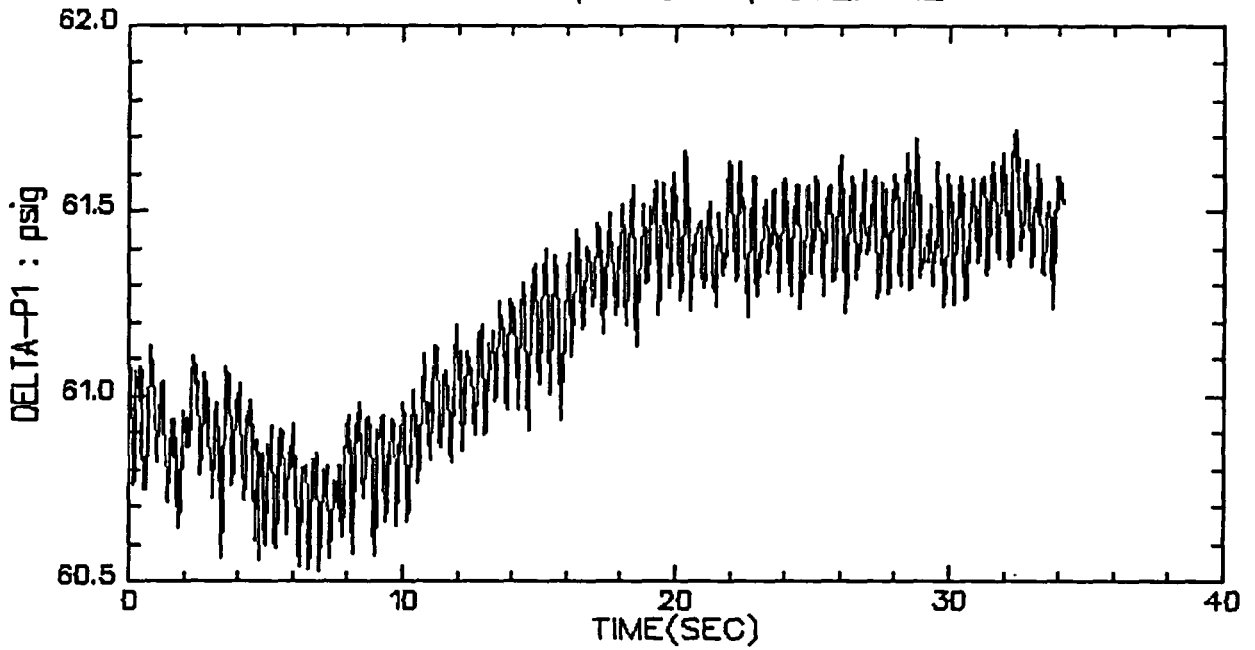

VALVE A, TEST 1, STEP 12

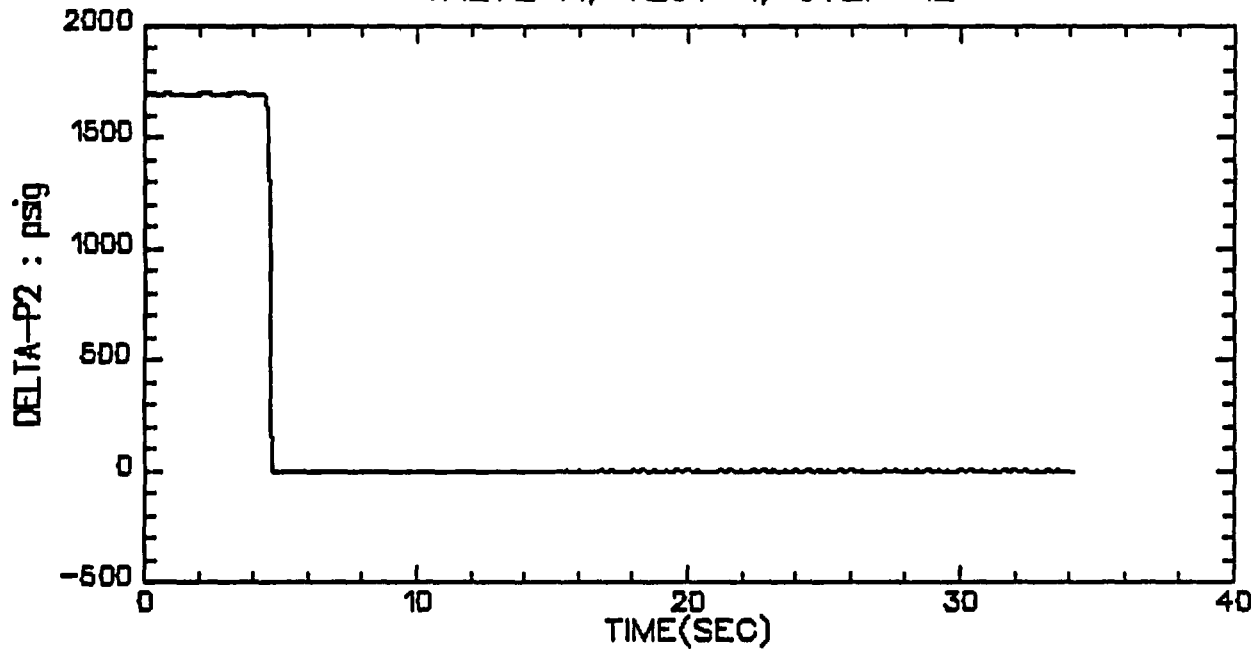

VALVE A, TEST 1, STEP 12

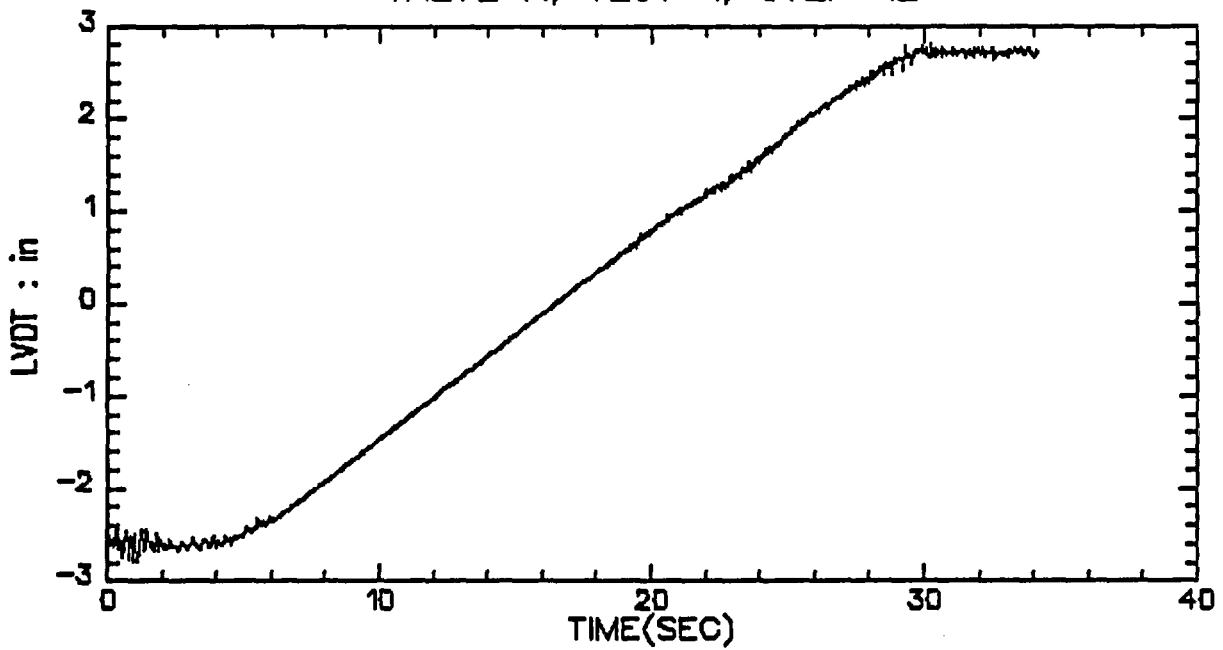

VALVE A, TEST 1, STEP 12

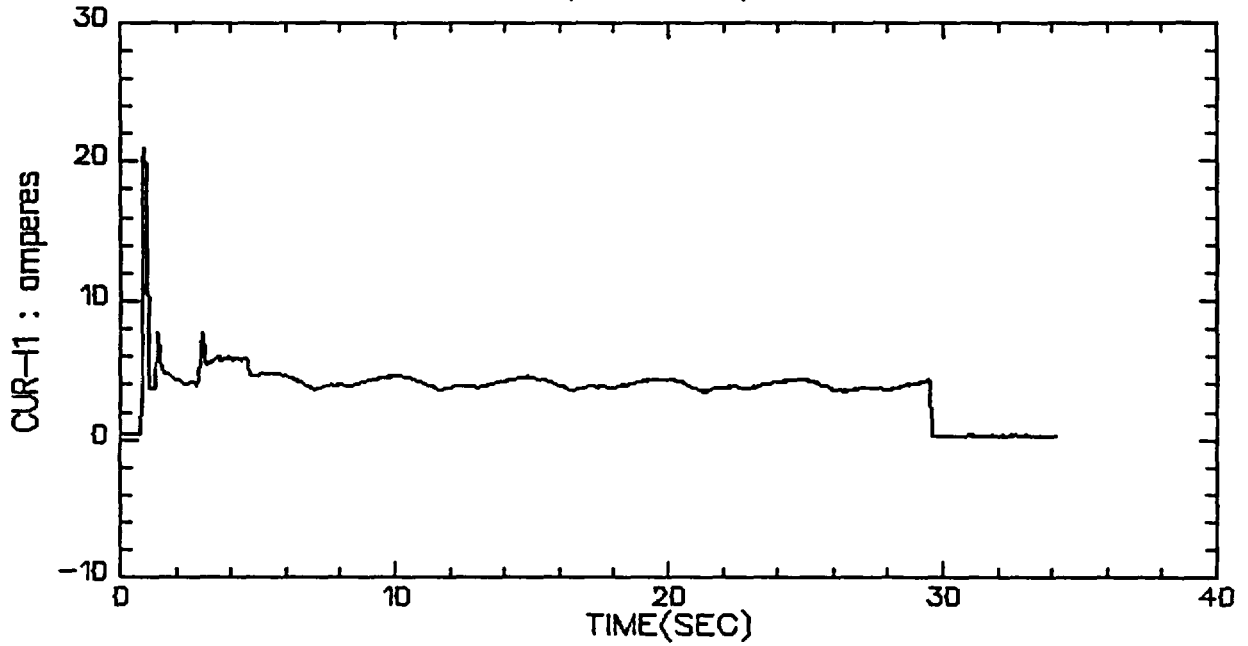

VALVE A, TEST 1, STEP 12

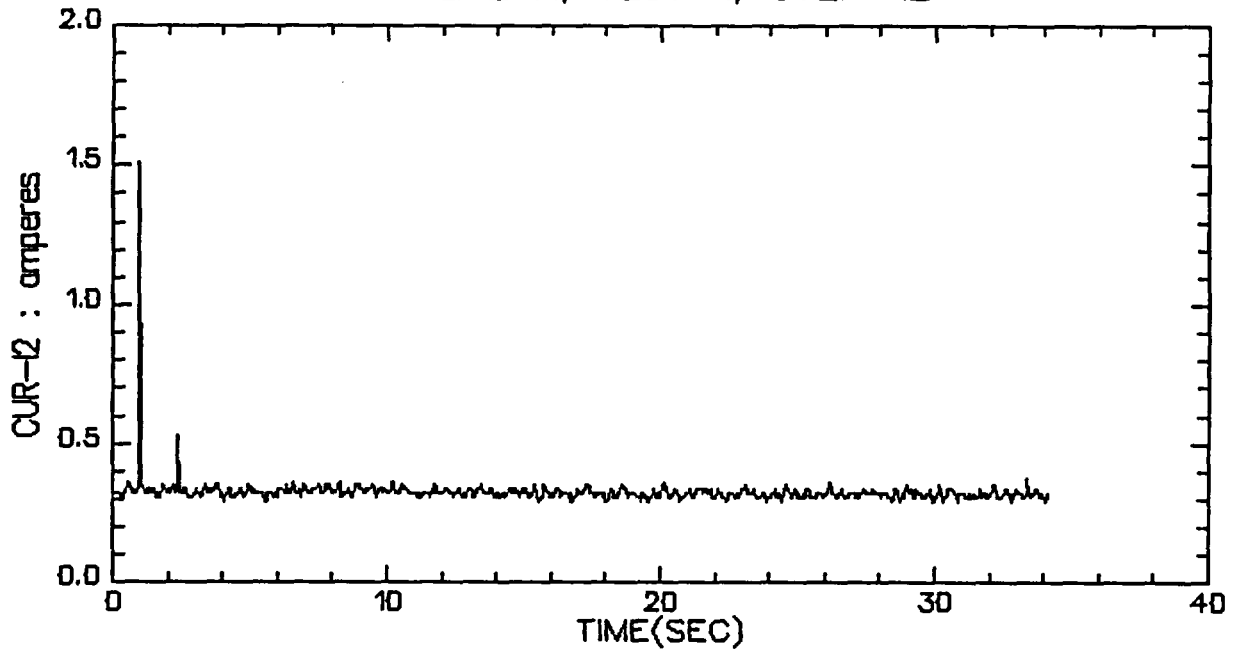

VALVE A, TEST 1, STEP 12

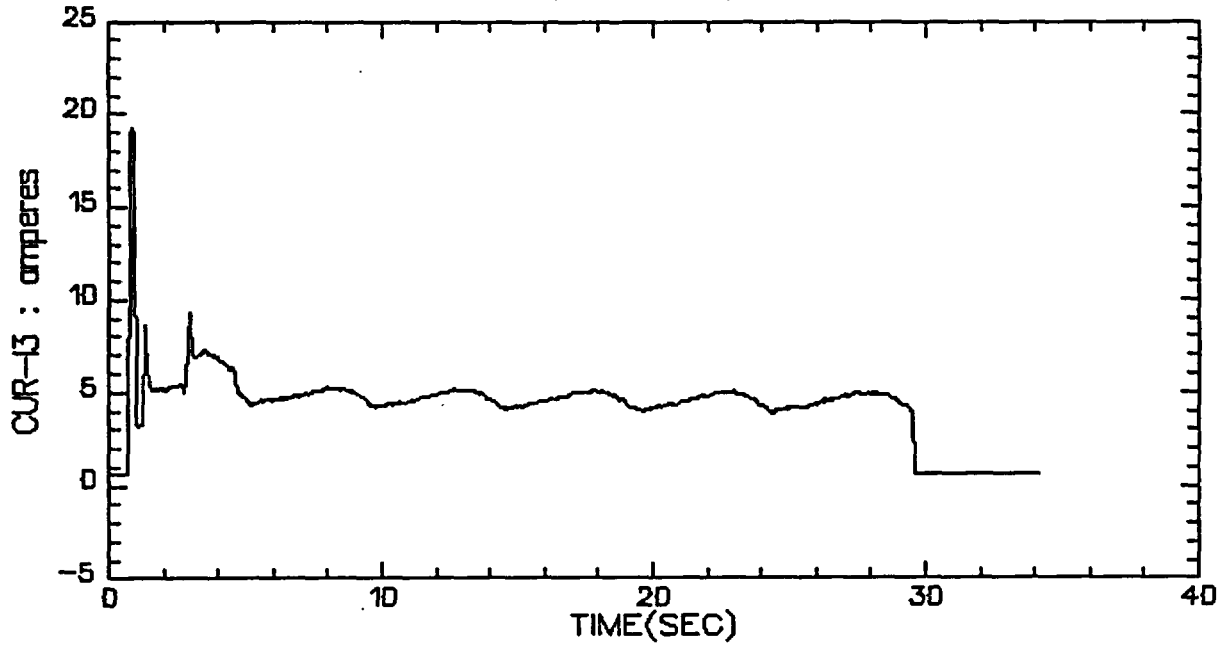

VALVE A, TEST 1, STEP 12

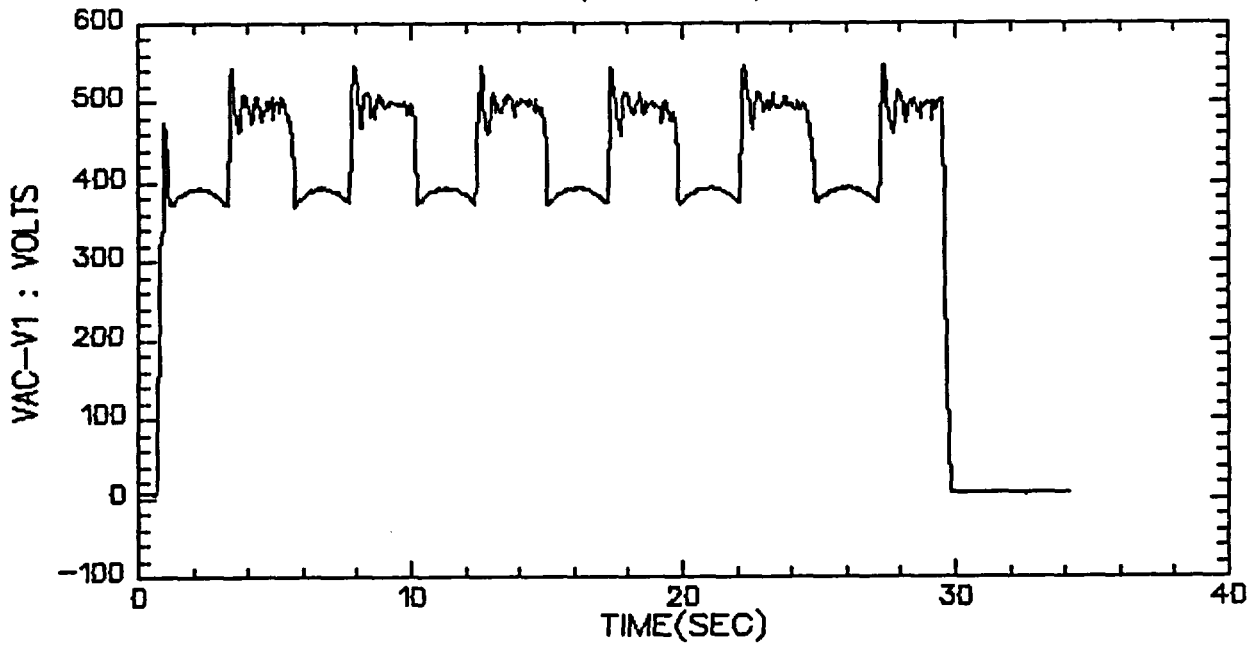

VALVE A, TEST 1, STEP 12

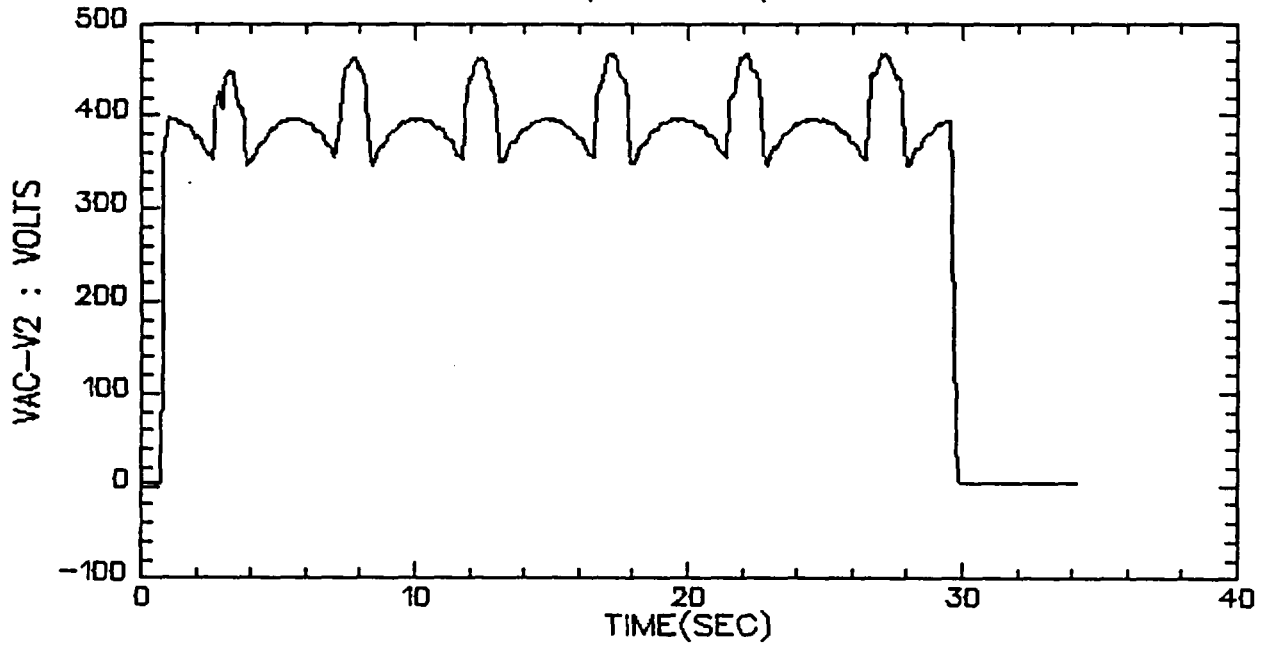

VALVE A, TEST 1, STEP 12

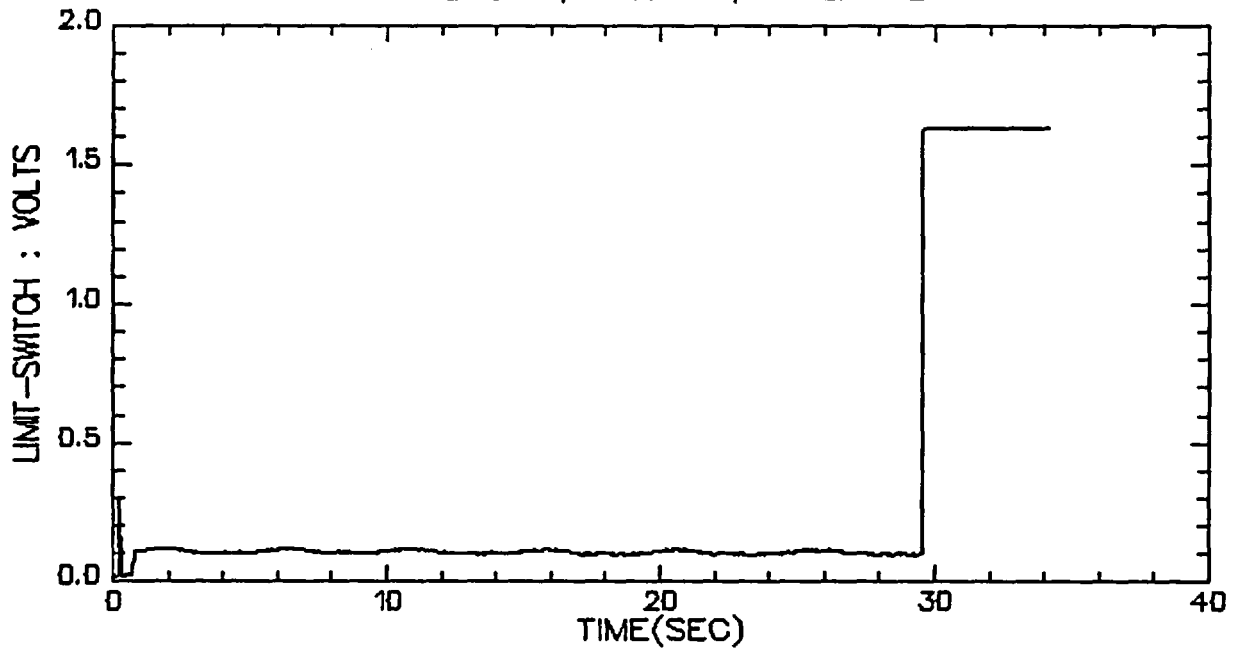

VALVE A, TEST 1, STEP 12

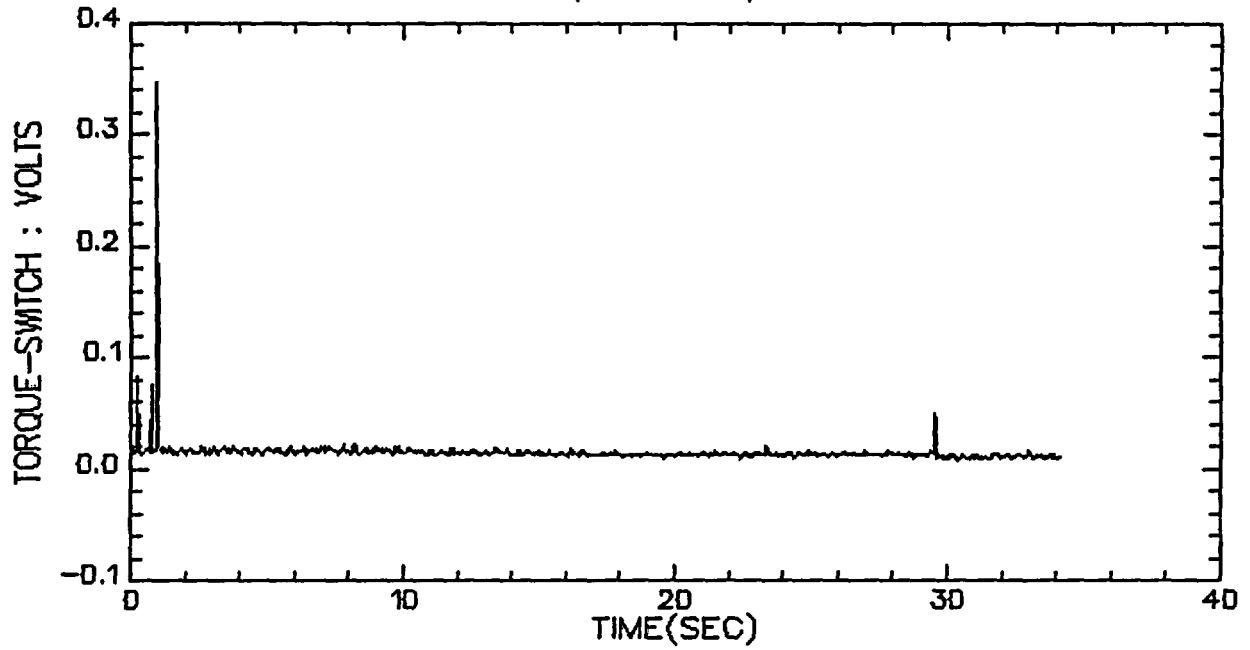

VALVE A, TEST 1, STEP 12

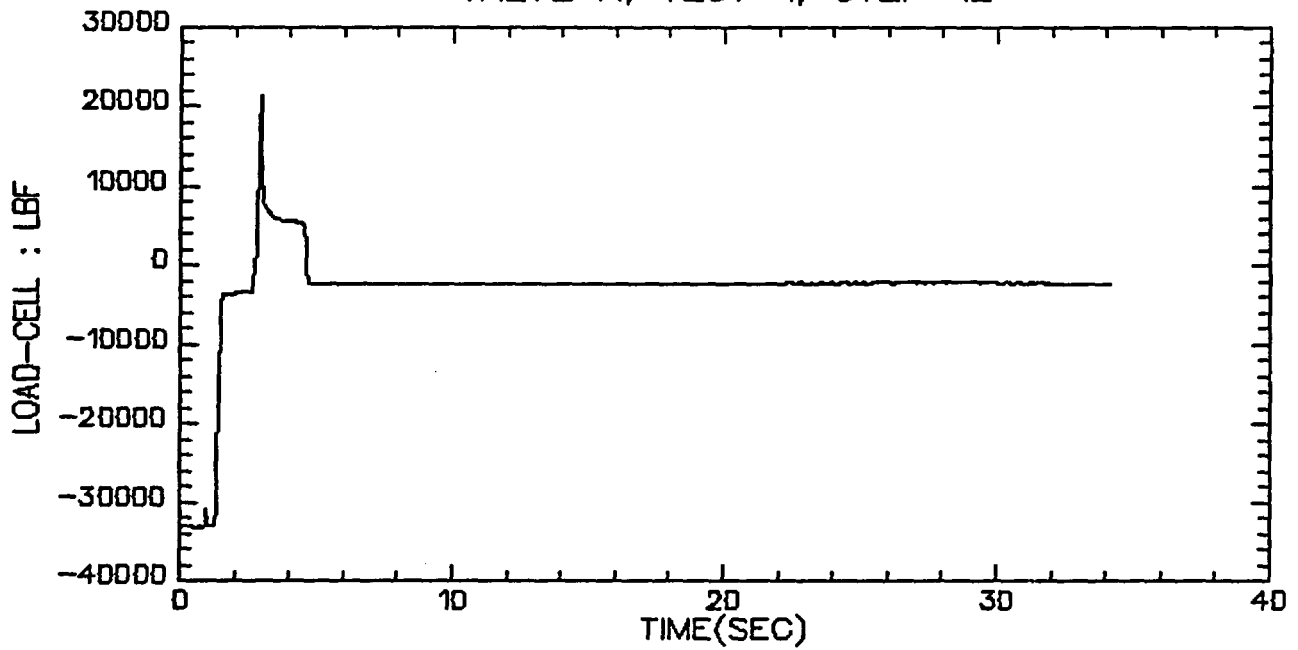

VALVE A, TEST 1, STEP 19

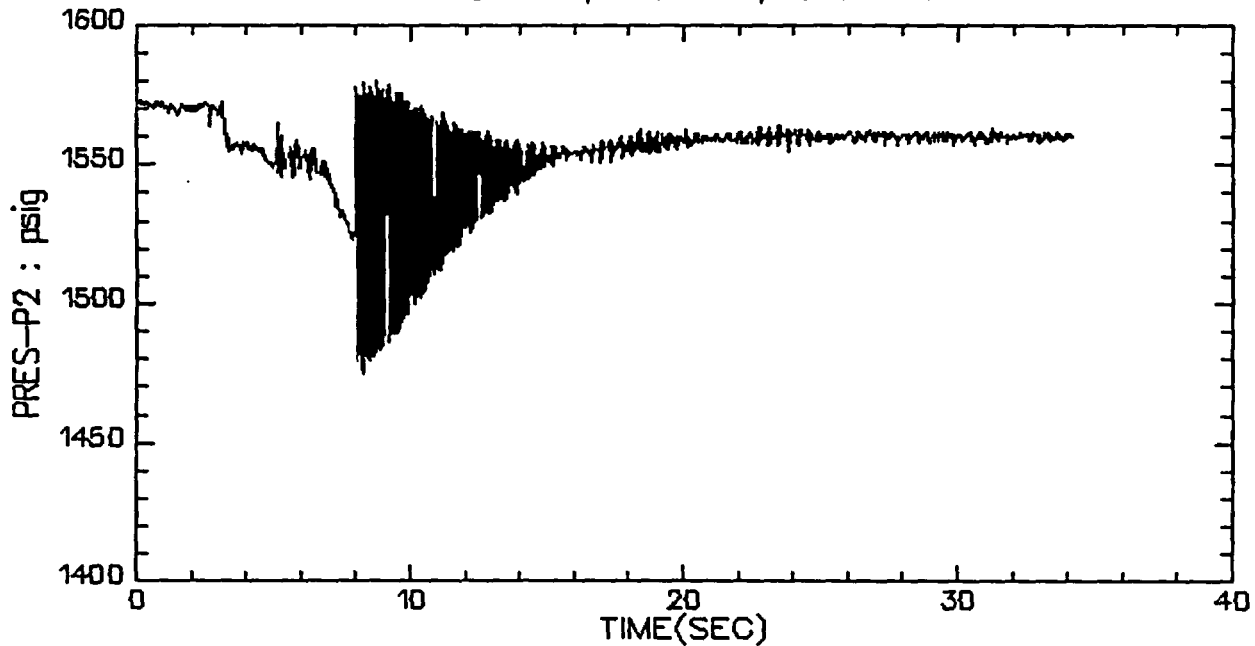

VALVE A, TEST 1, STEP 19

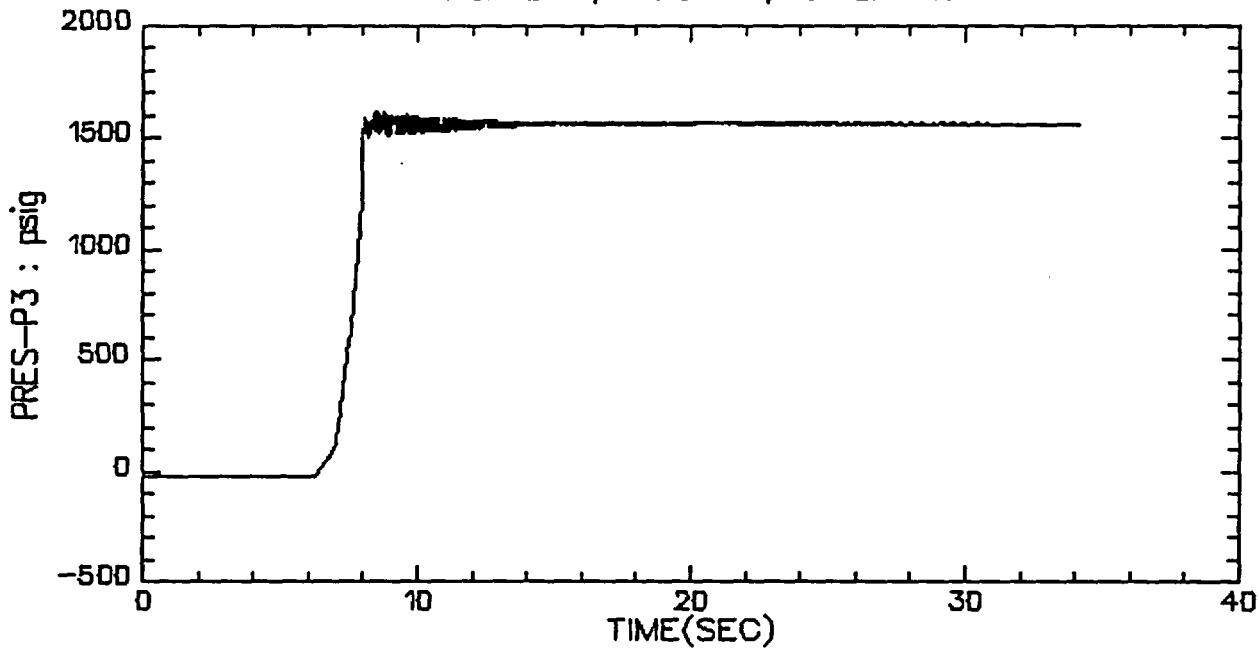

VALVE A, TEST 1, STEP 19

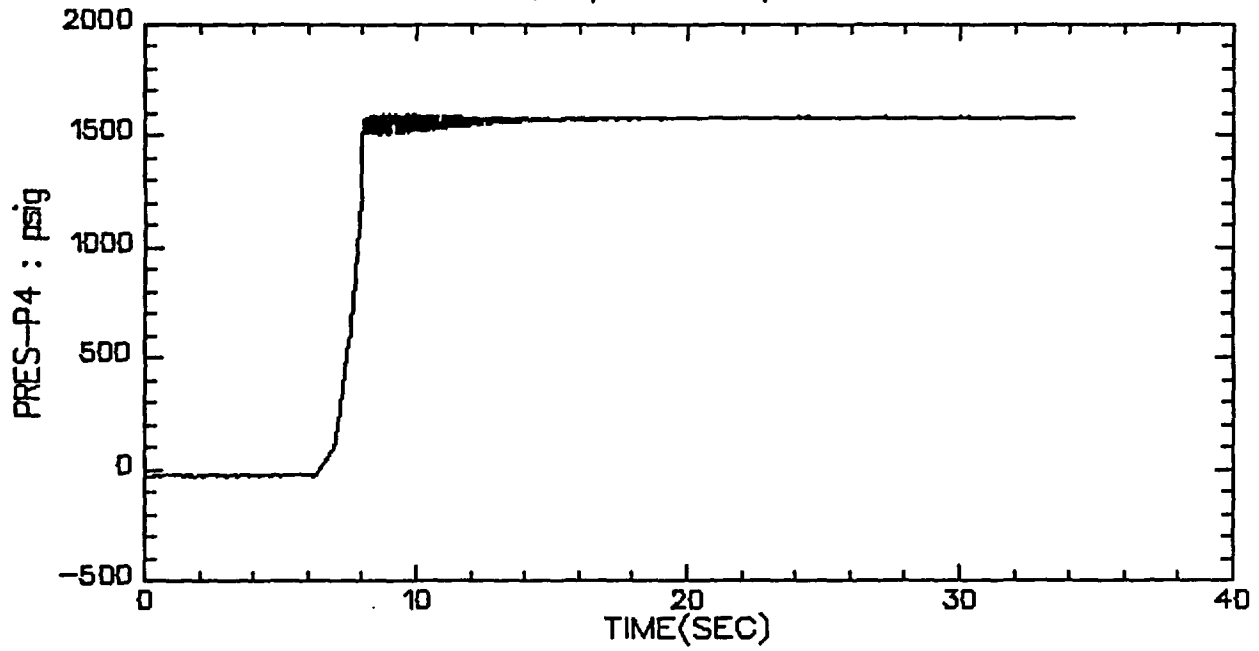

VALVE A, TEST 1, STEP 19

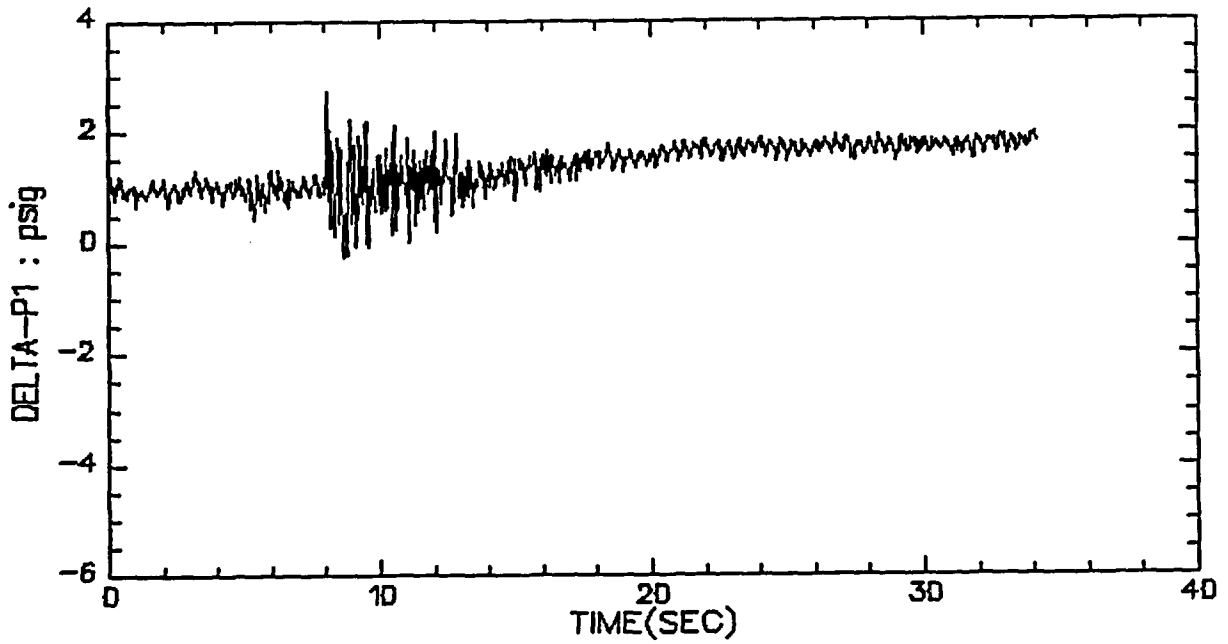

VALVE A, TEST 1, STEP 19

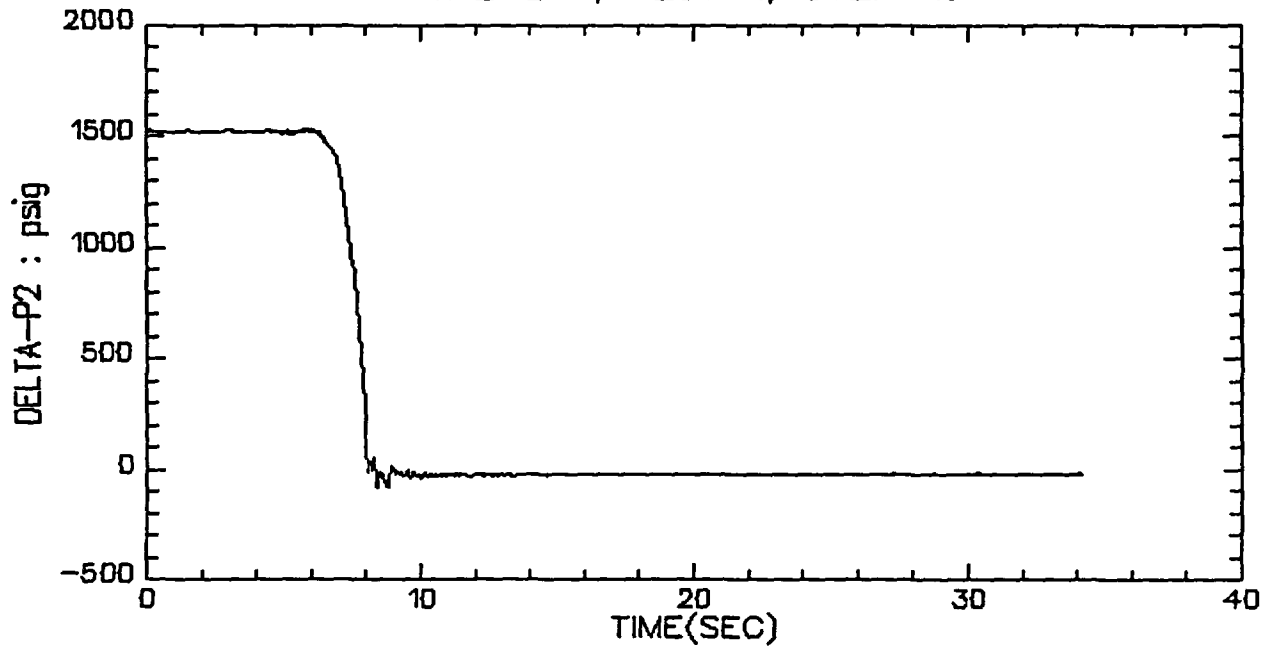

VALVE A, TEST 1, STEP 19

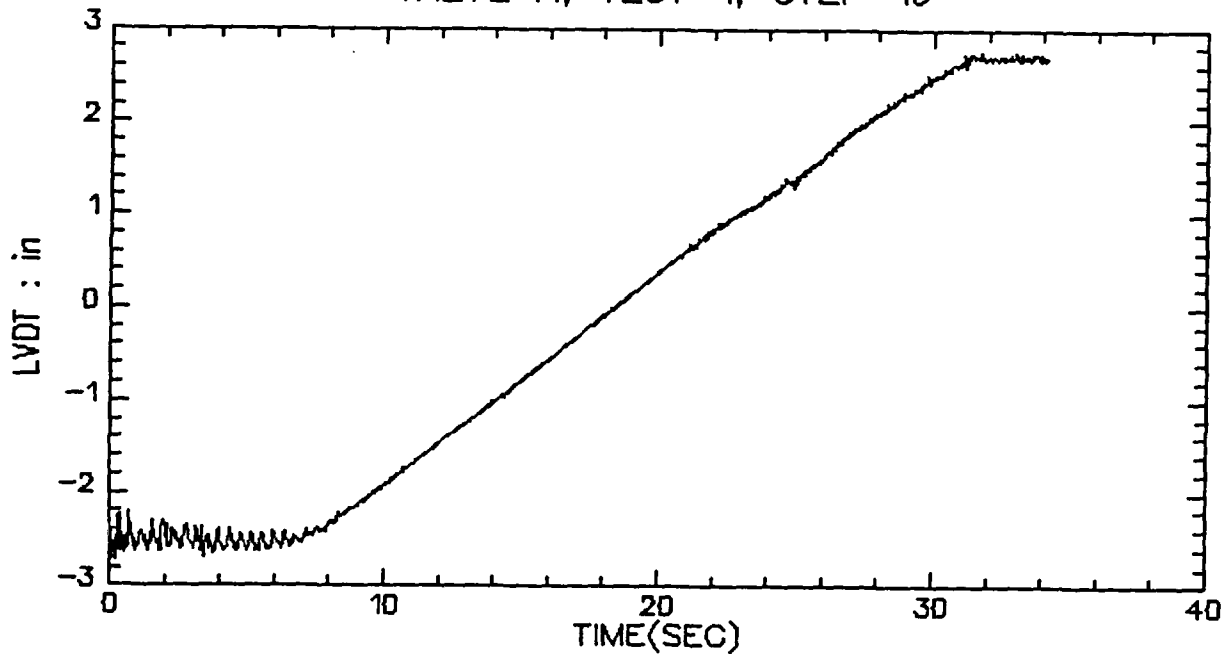

VALVE A, TEST 1, STEP 19

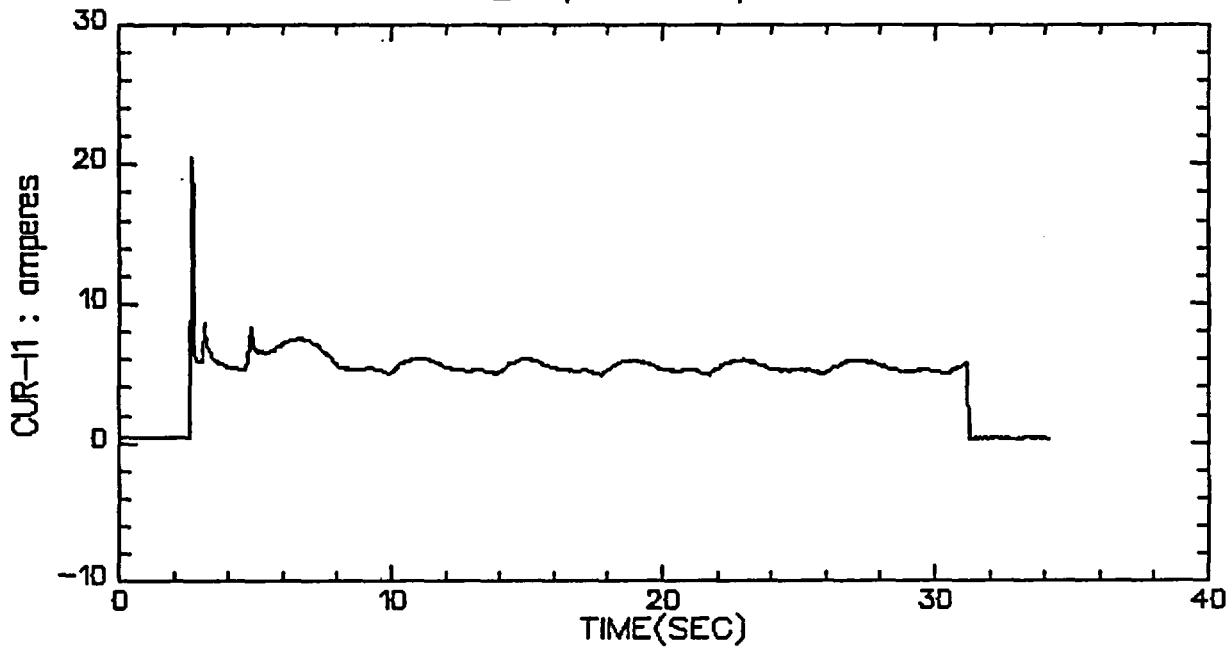

VALVE A, TEST 1, STEP 19

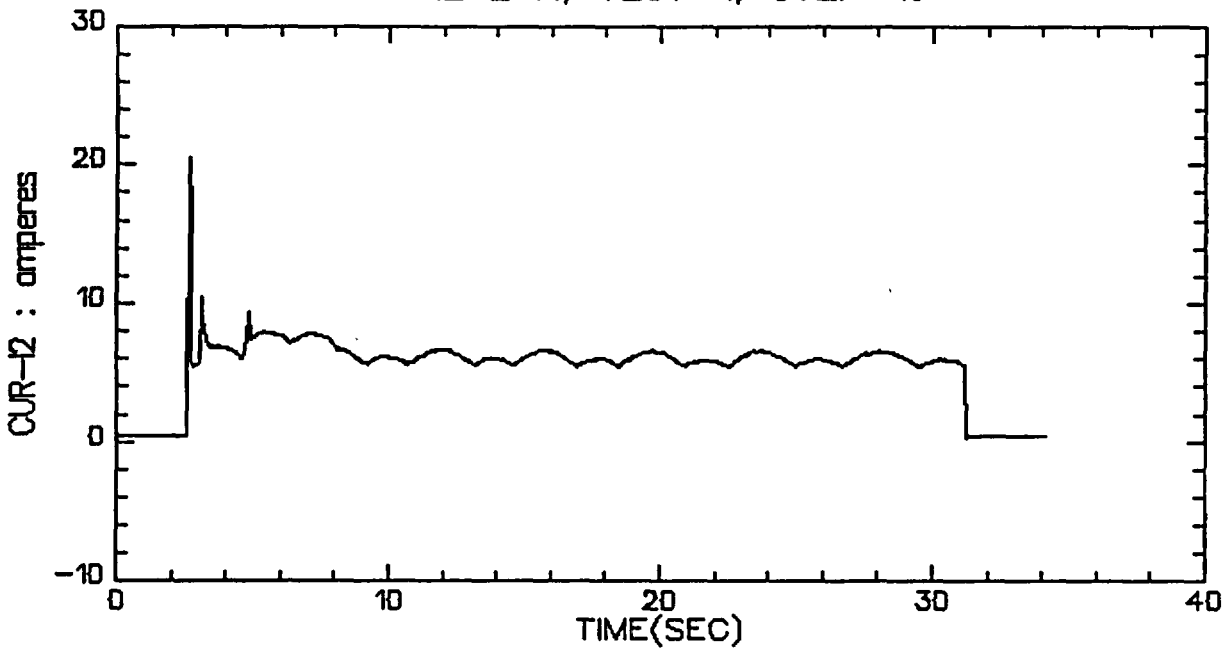

VALVE A, TEST 1, STEP 19

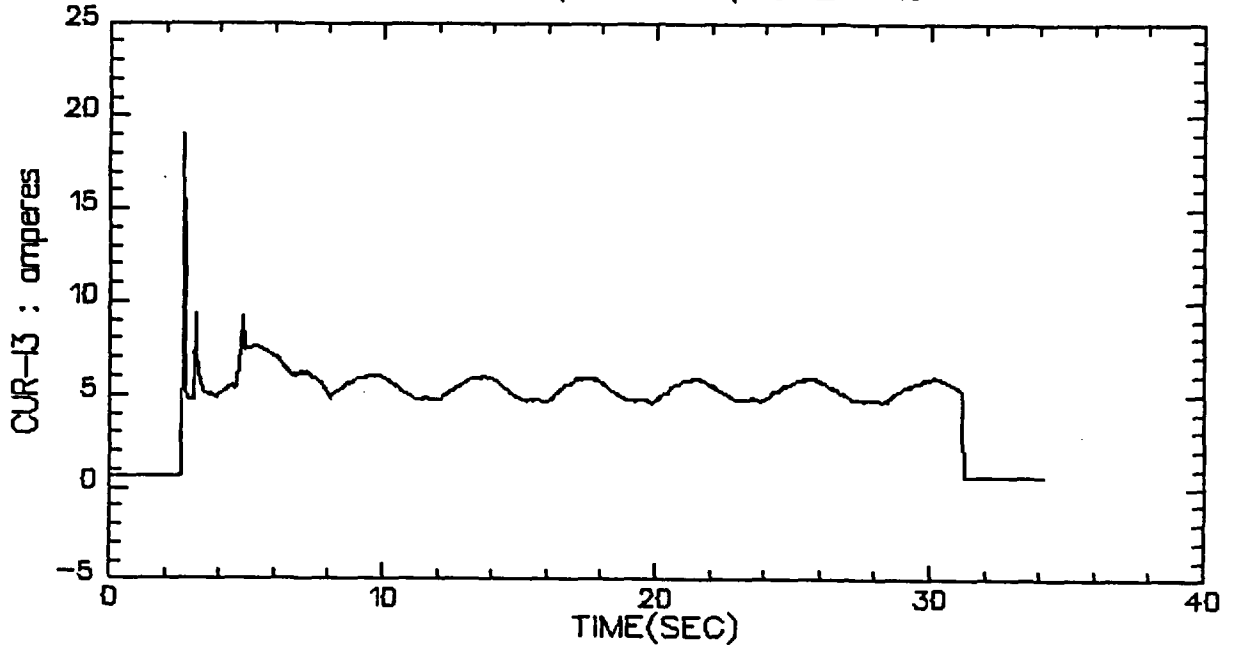

VALVE A, TEST 1, STEP 19

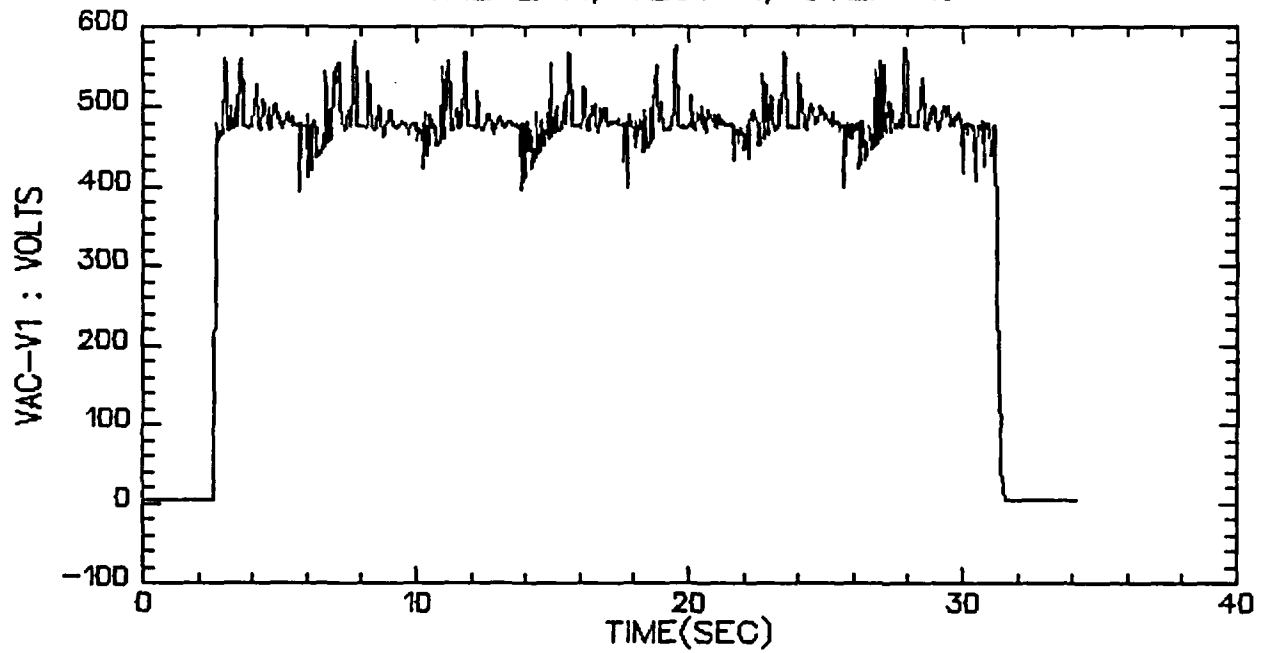

VALVE A, TEST 1, STEP 19

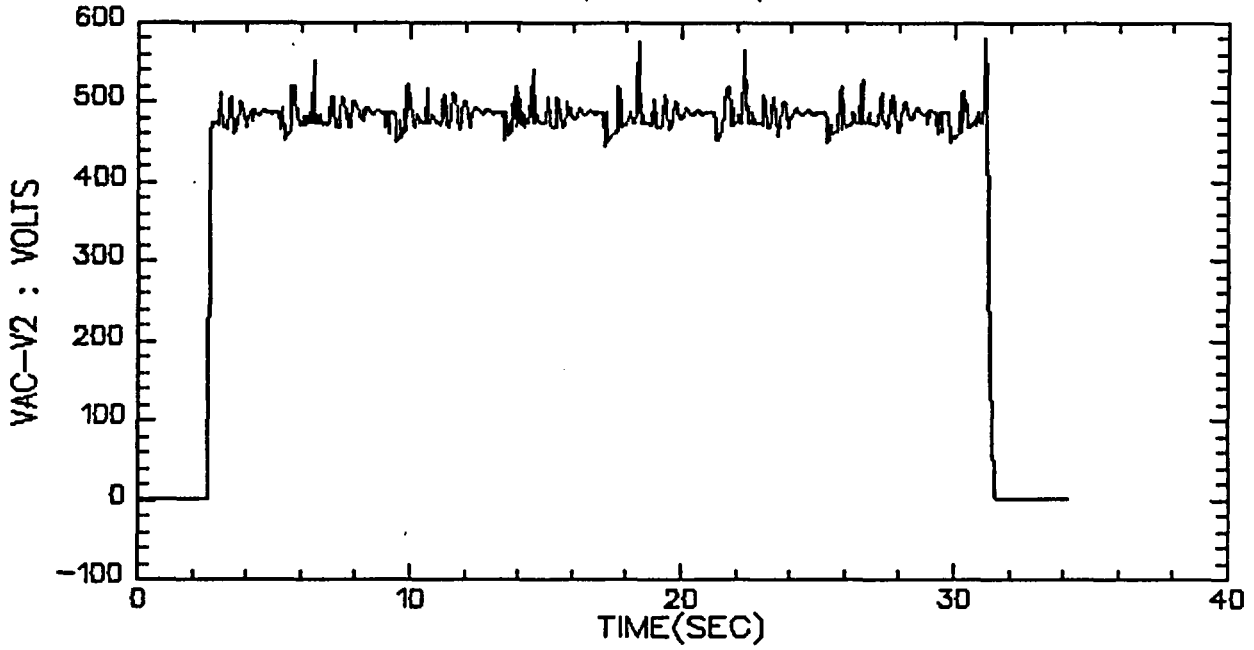

VALVE A, TEST 1, STEP 19

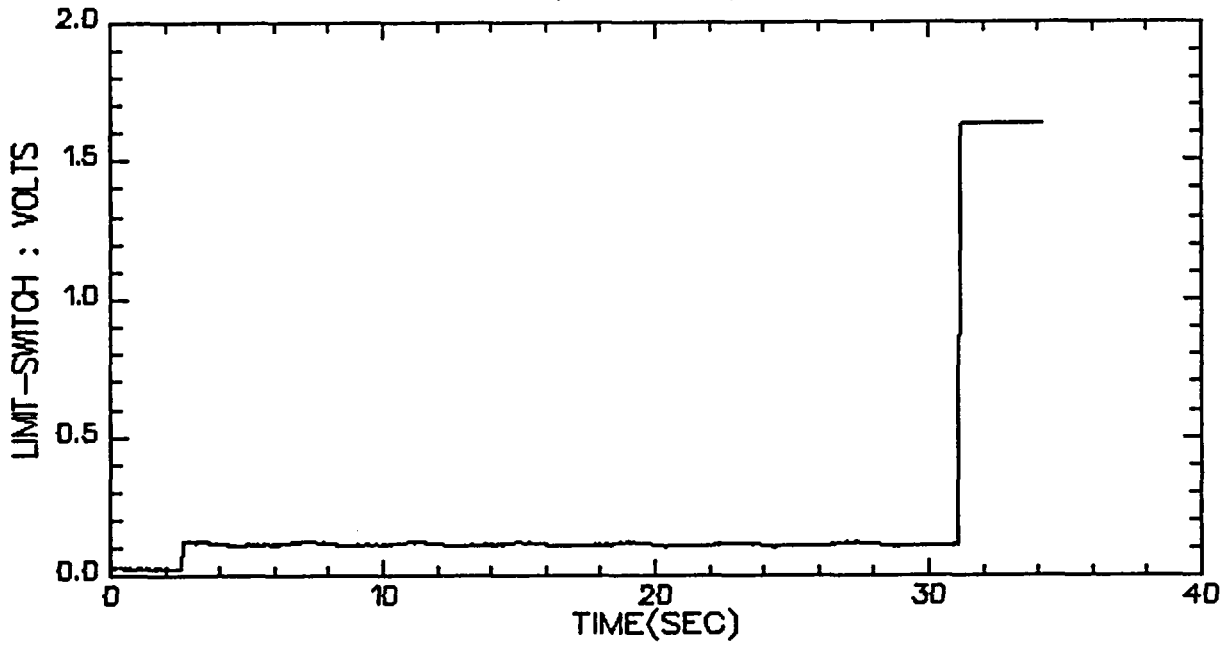

VALVE A, TEST 1, STEP 19

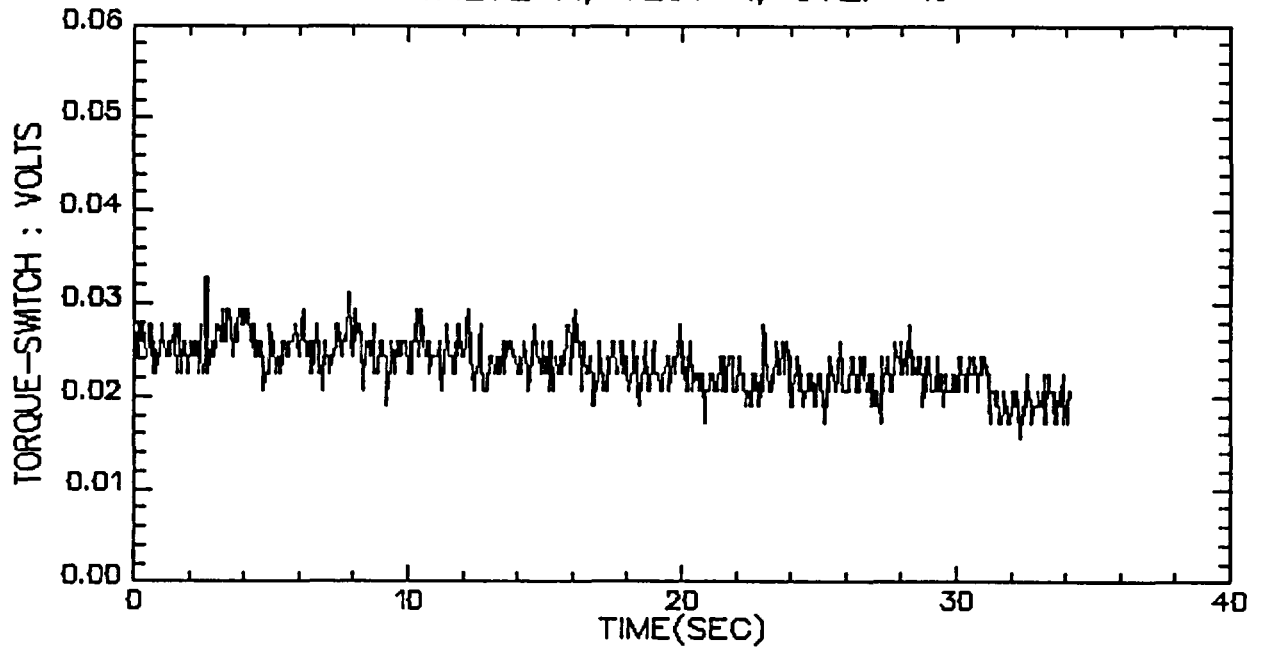

VALVE A, TEST 1, STEP 19

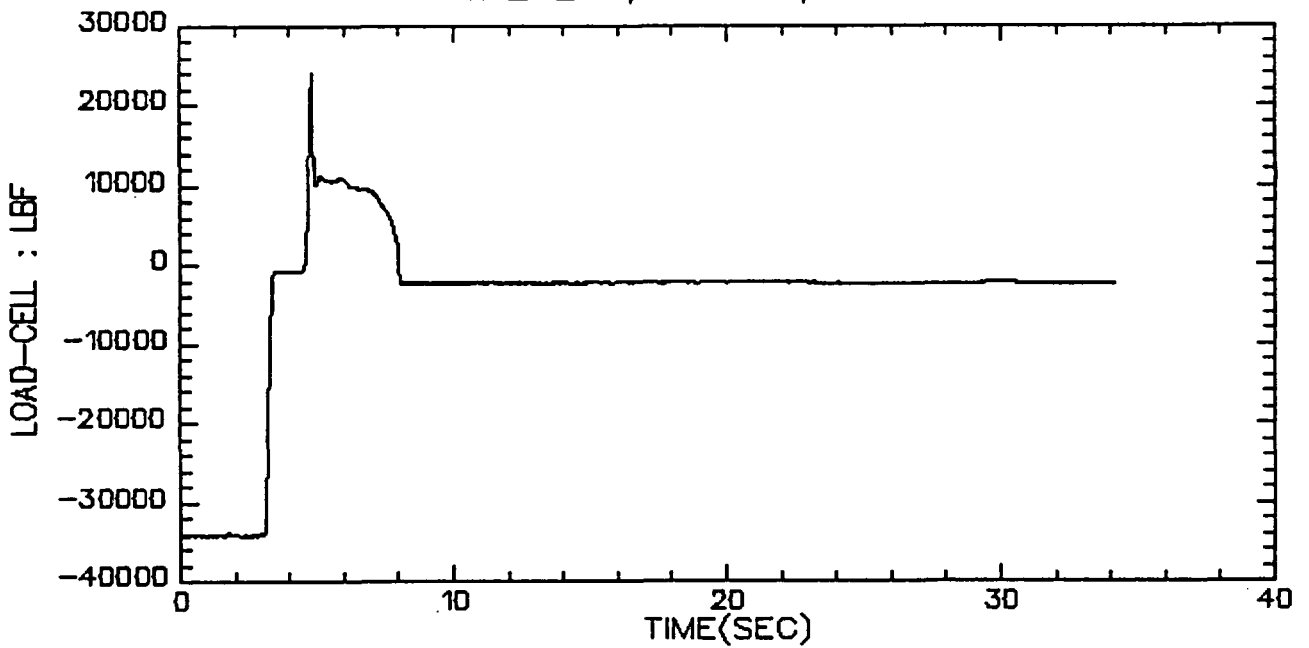

VALVE A, TEST 2, STEP 1

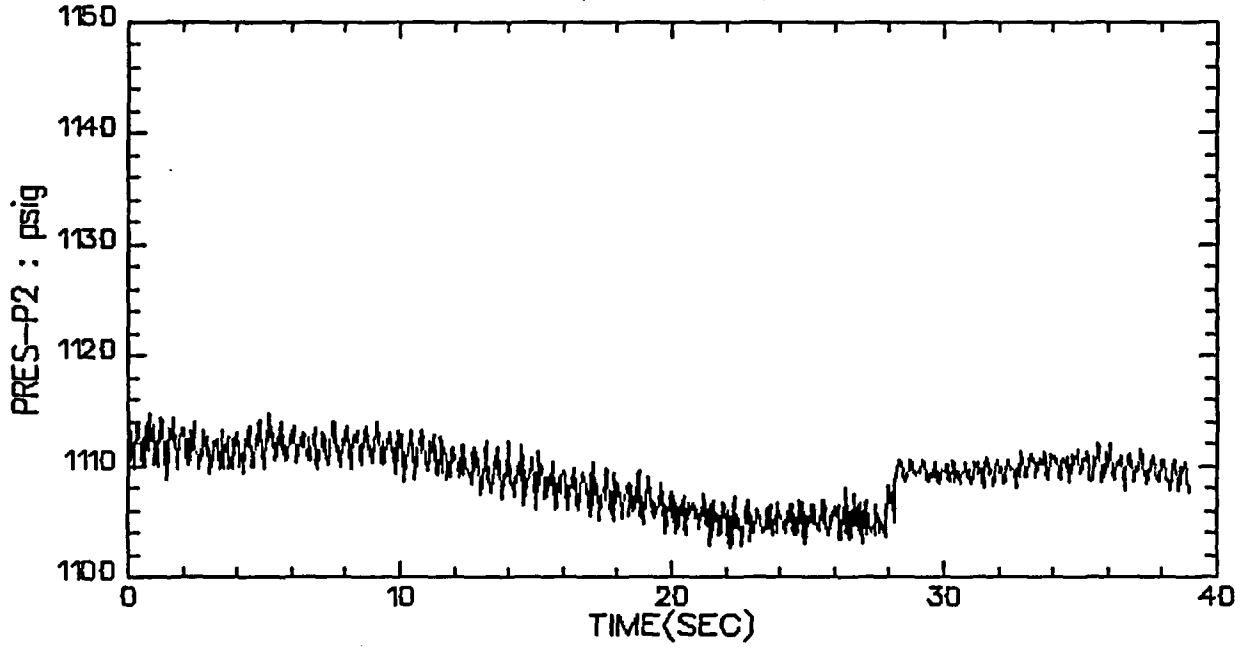

VALVE A, TEST 2, STEP 1

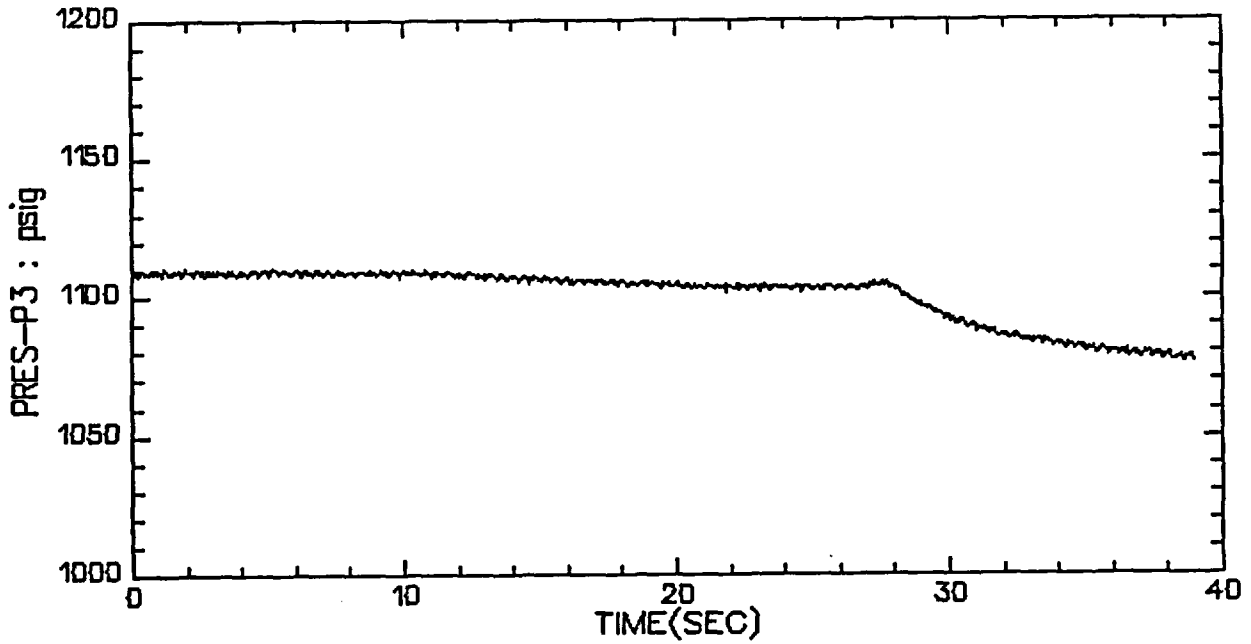

VALVE A, TEST 2, STEP 1

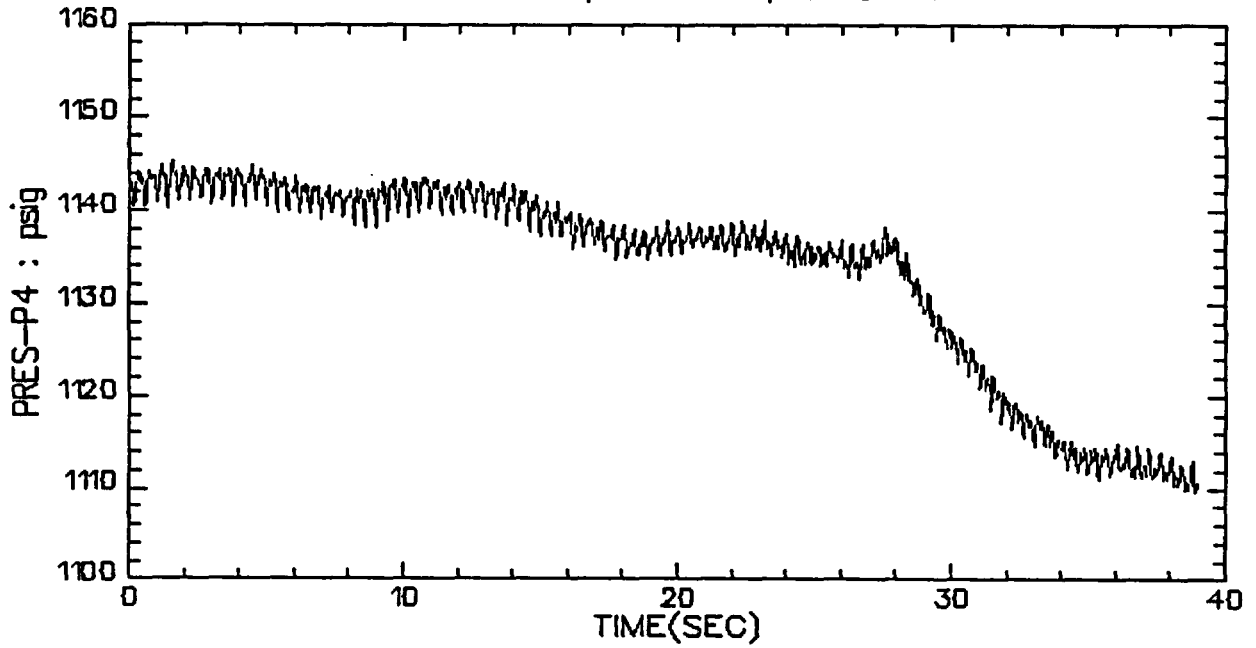

VALVE A, TEST 2, STEP 1

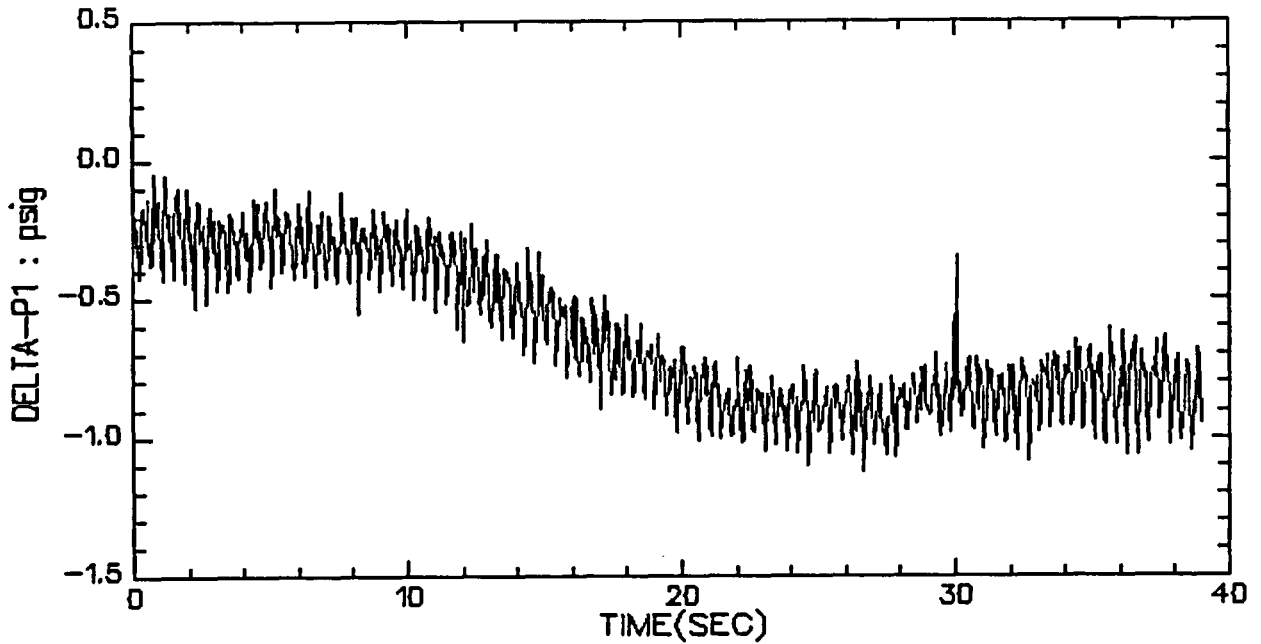

VALVE A, TEST 2, STEP 1

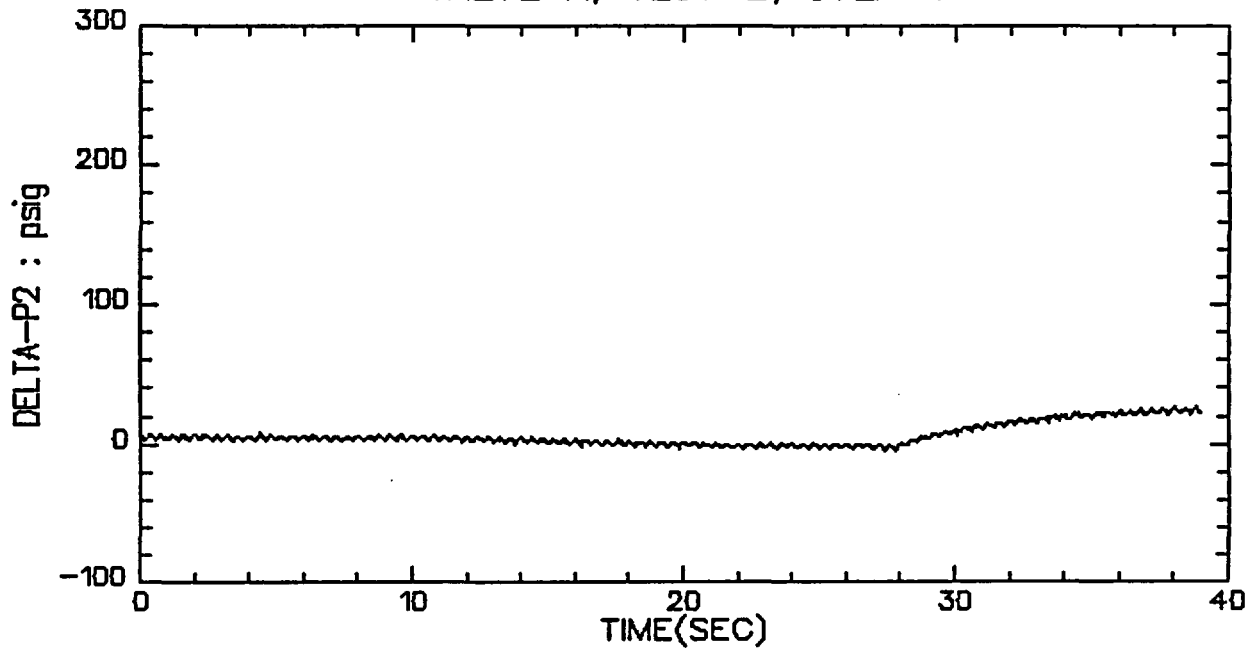

VALVE A, TEST 2, STEP 1

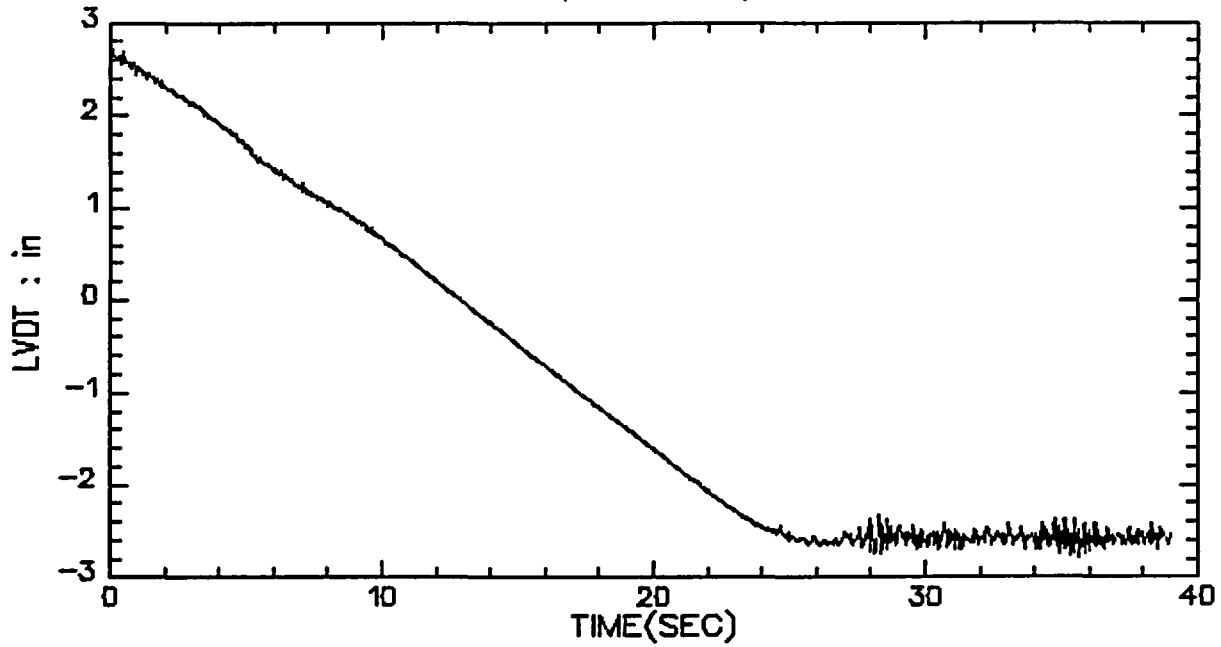

VALVE A, TEST 2, STEP 1

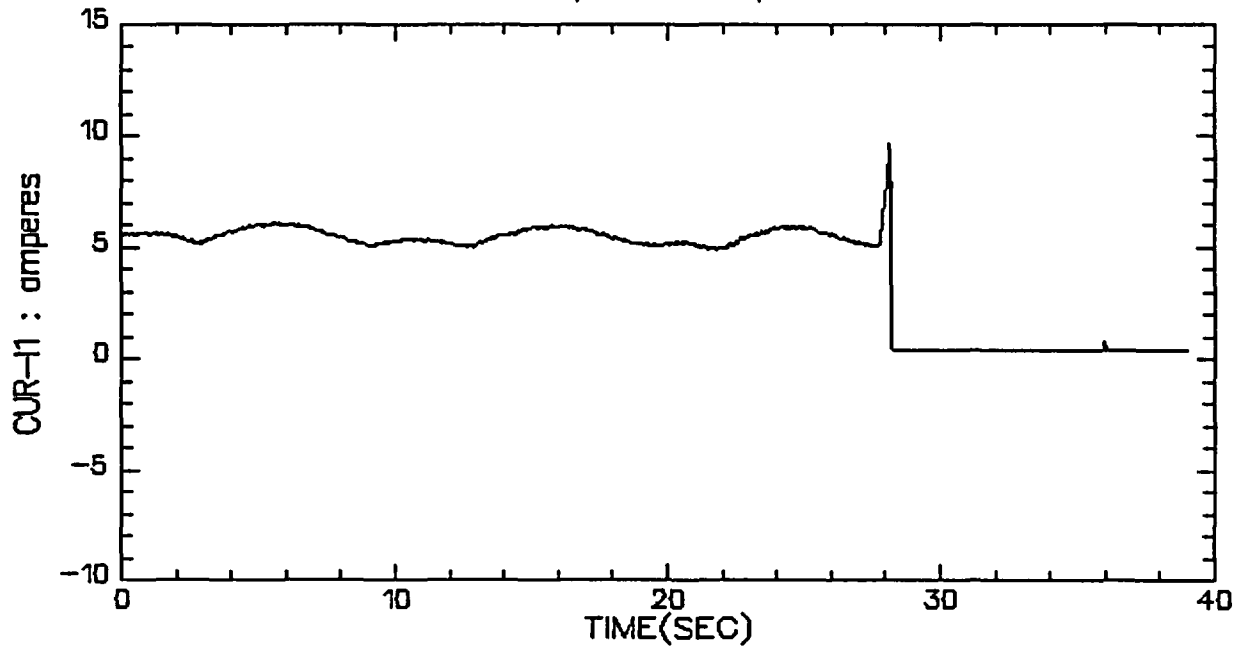

VALVE A, TEST 2, STEP 1

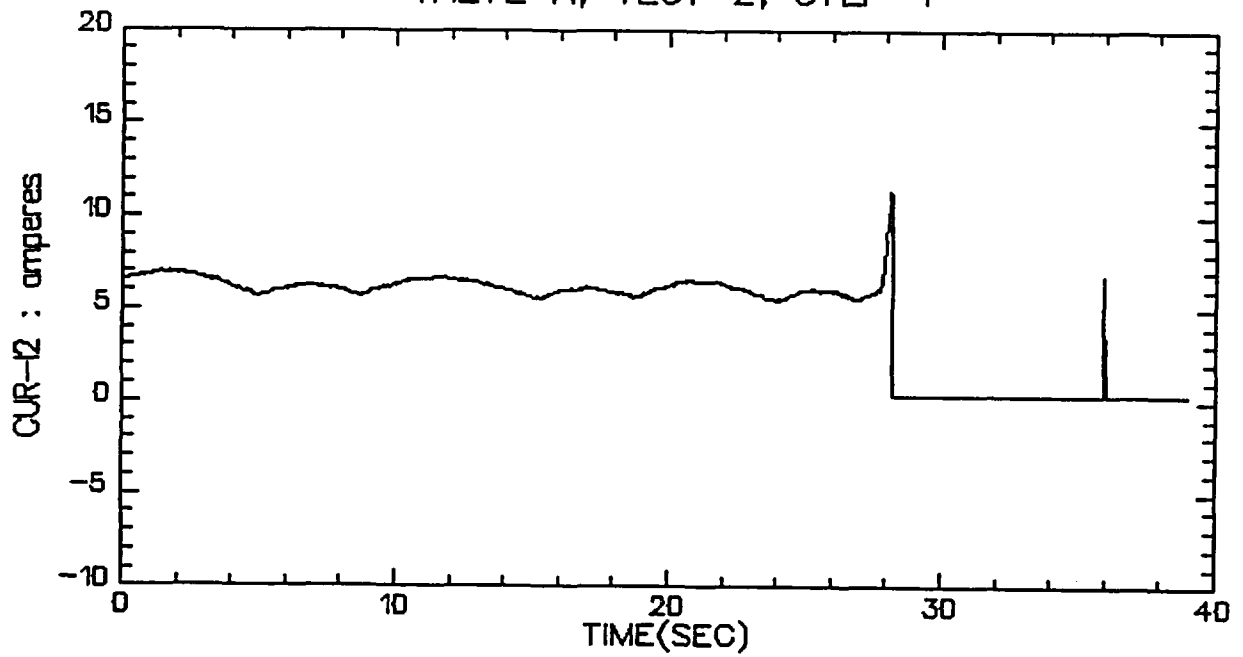

VALVE A, TEST 2, STEP 1

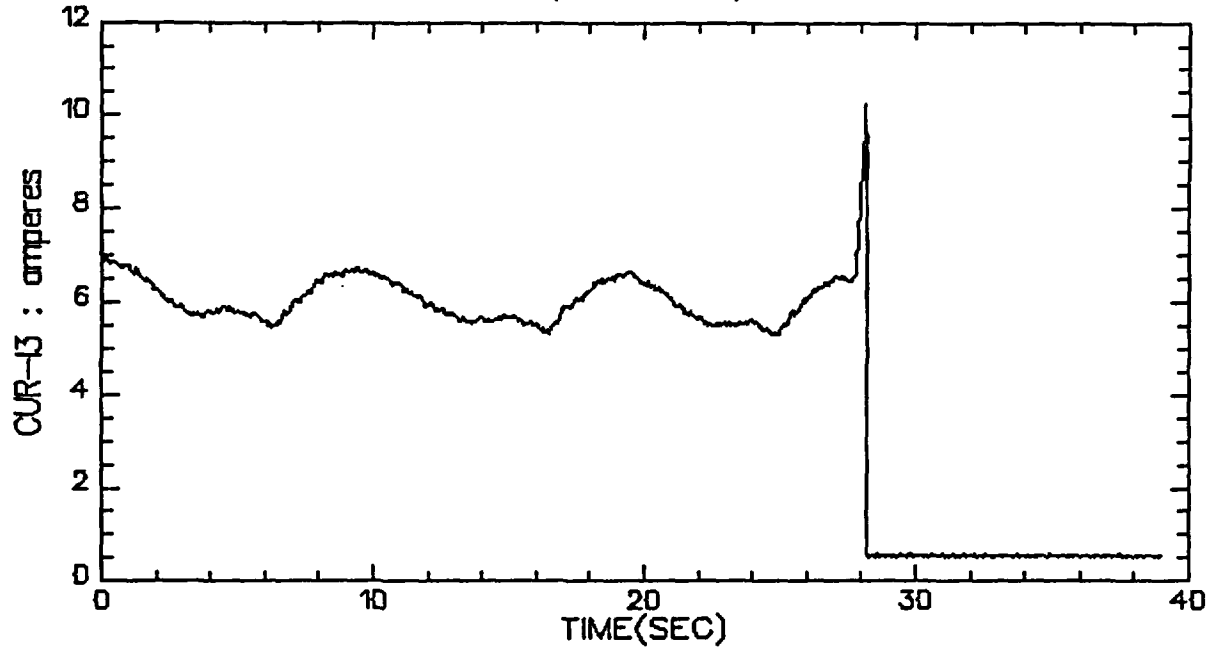

VALVE A, TEST 2, STEP 1

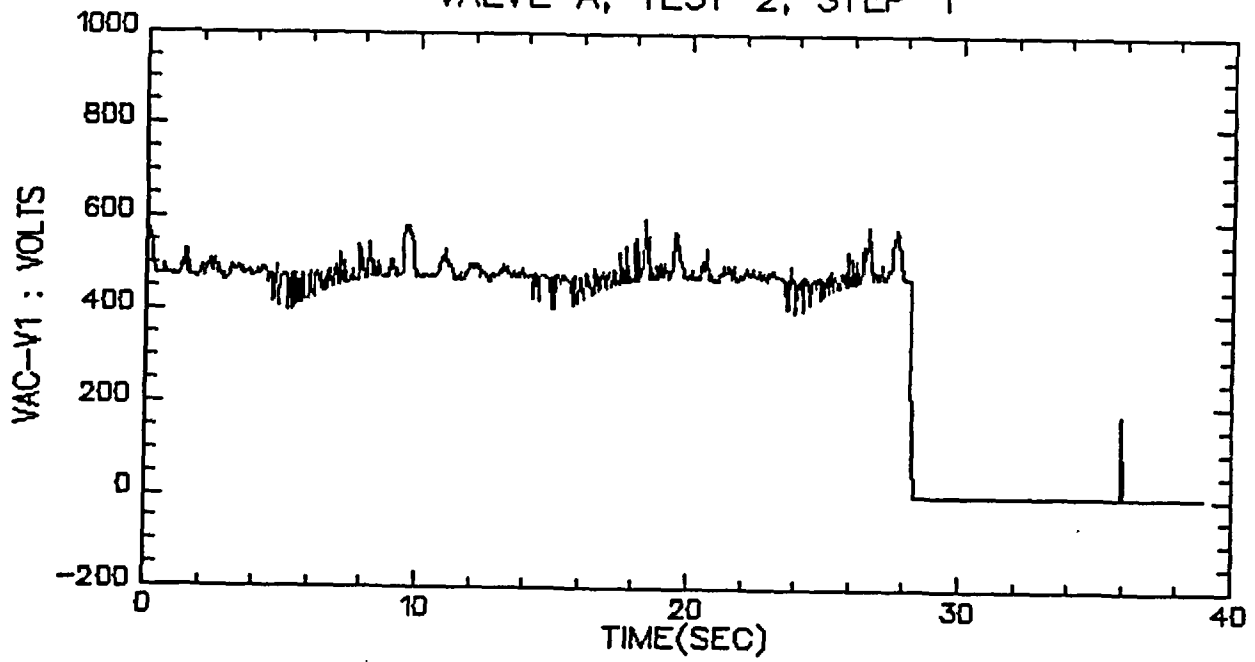

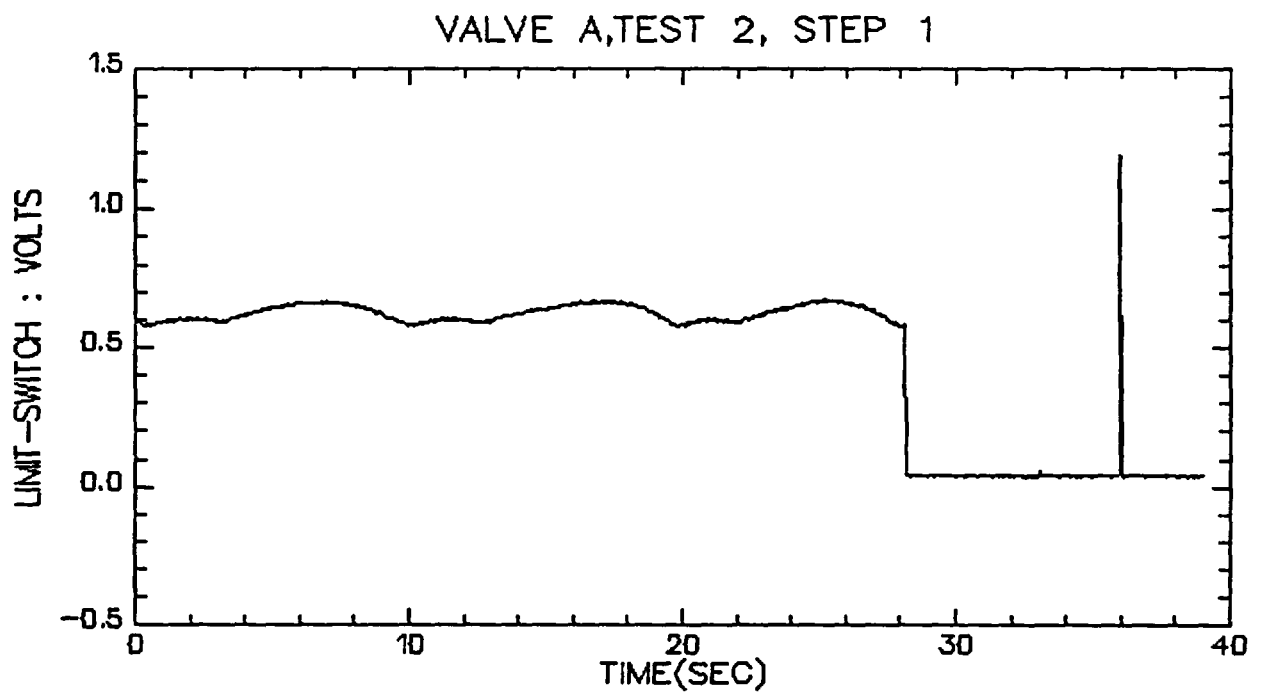
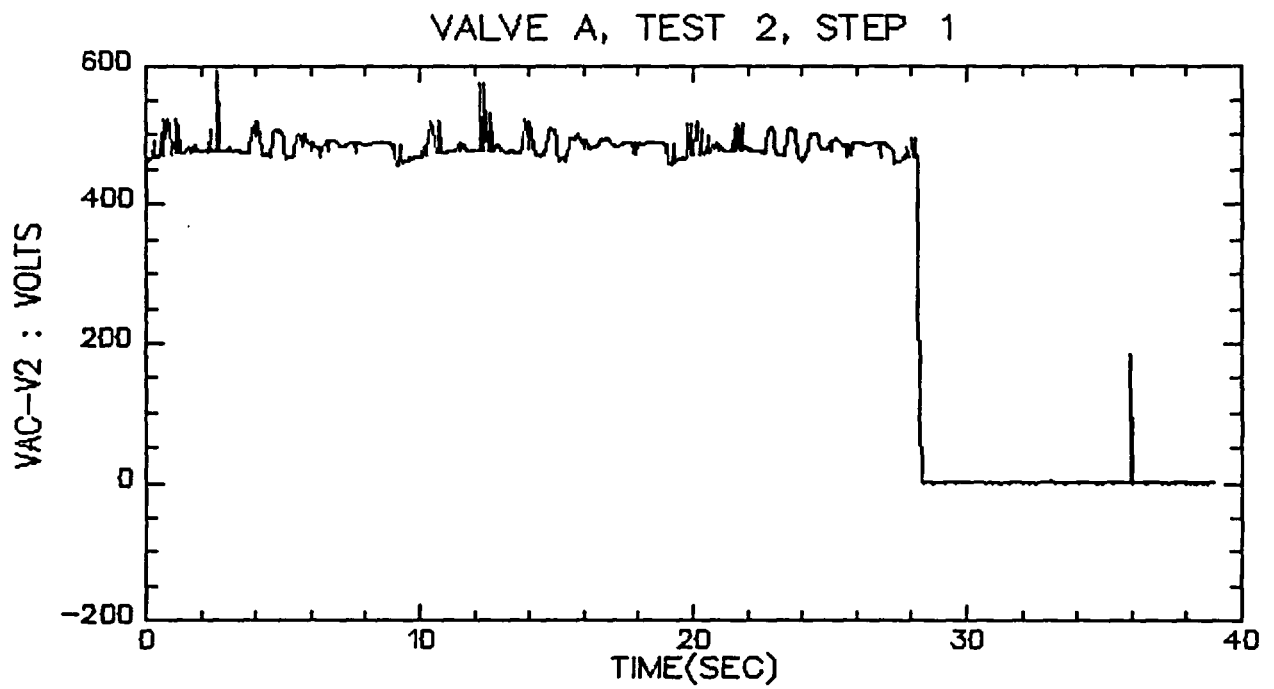

VALVE A, TEST 2, STEP 1

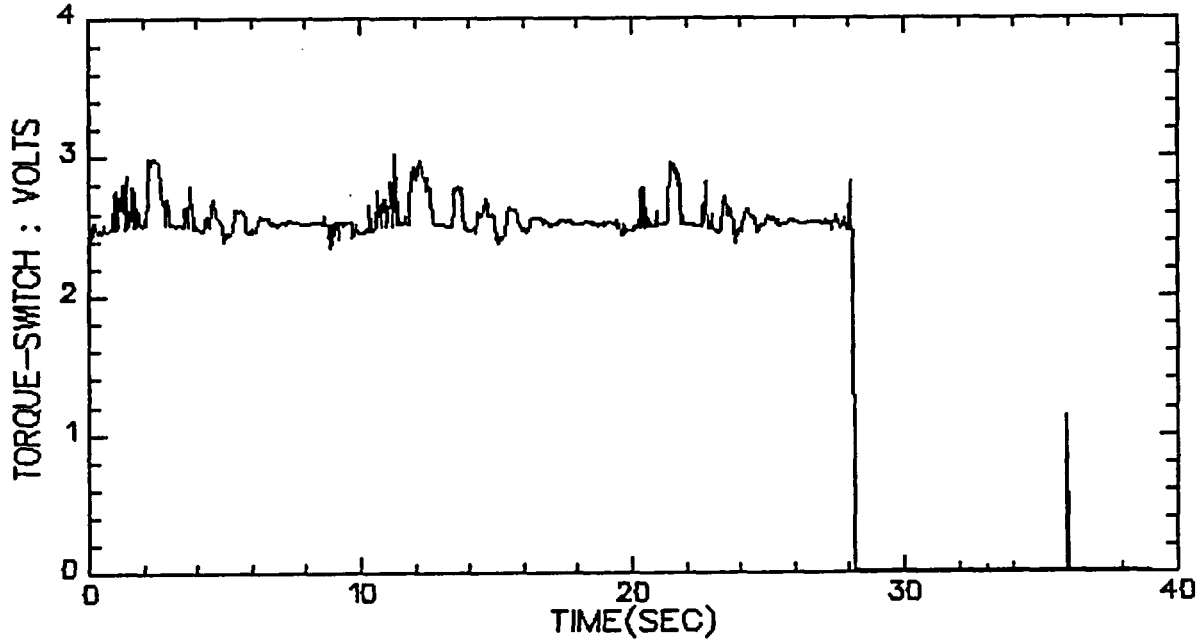

VALVE A, TEST 2, STEP 1

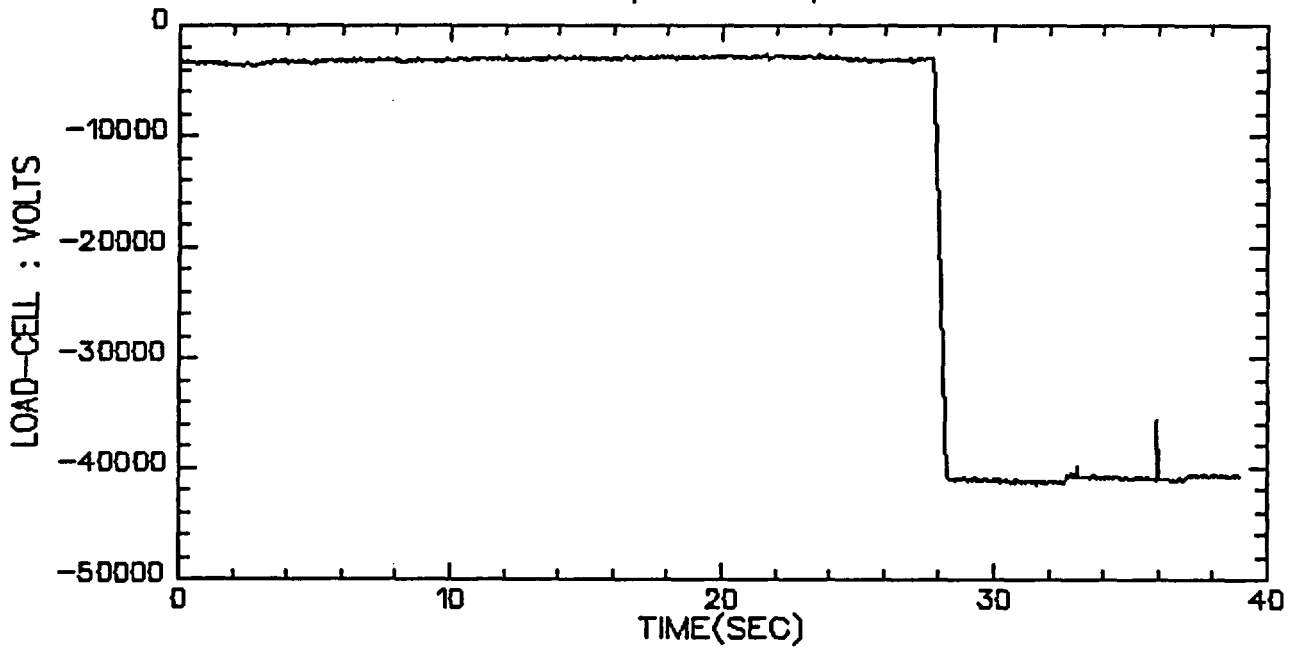

VALVE A, TEST 2, STEP 2

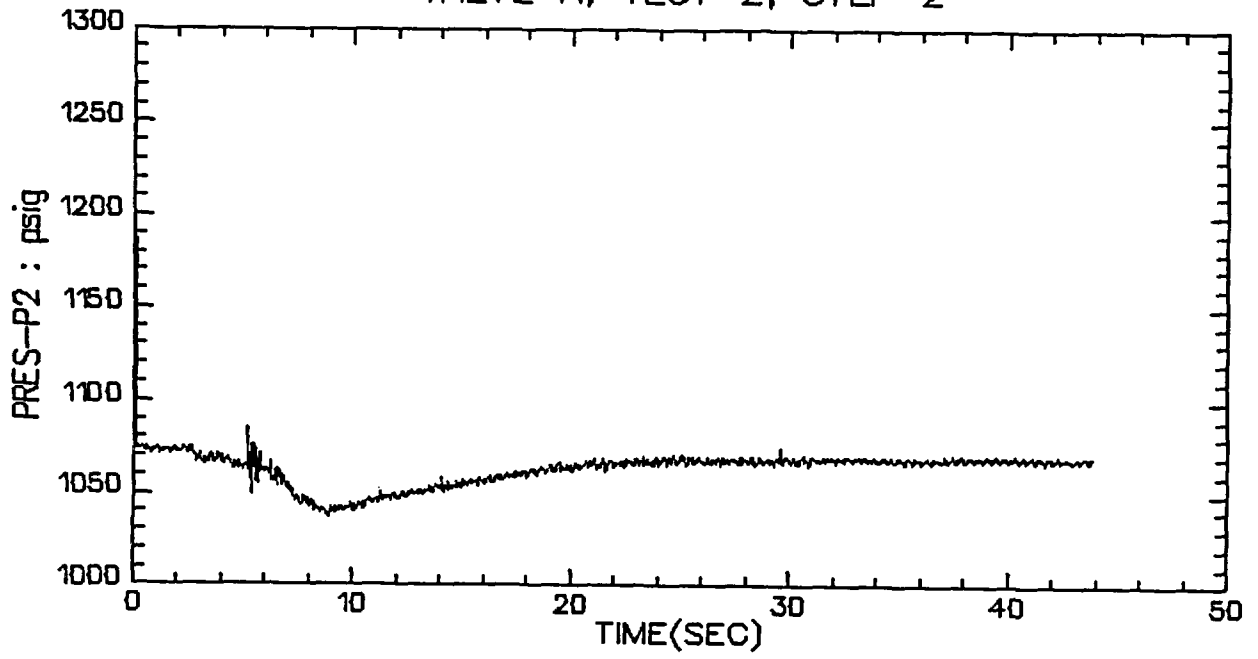

VALVE A, TEST 2, STEP 2

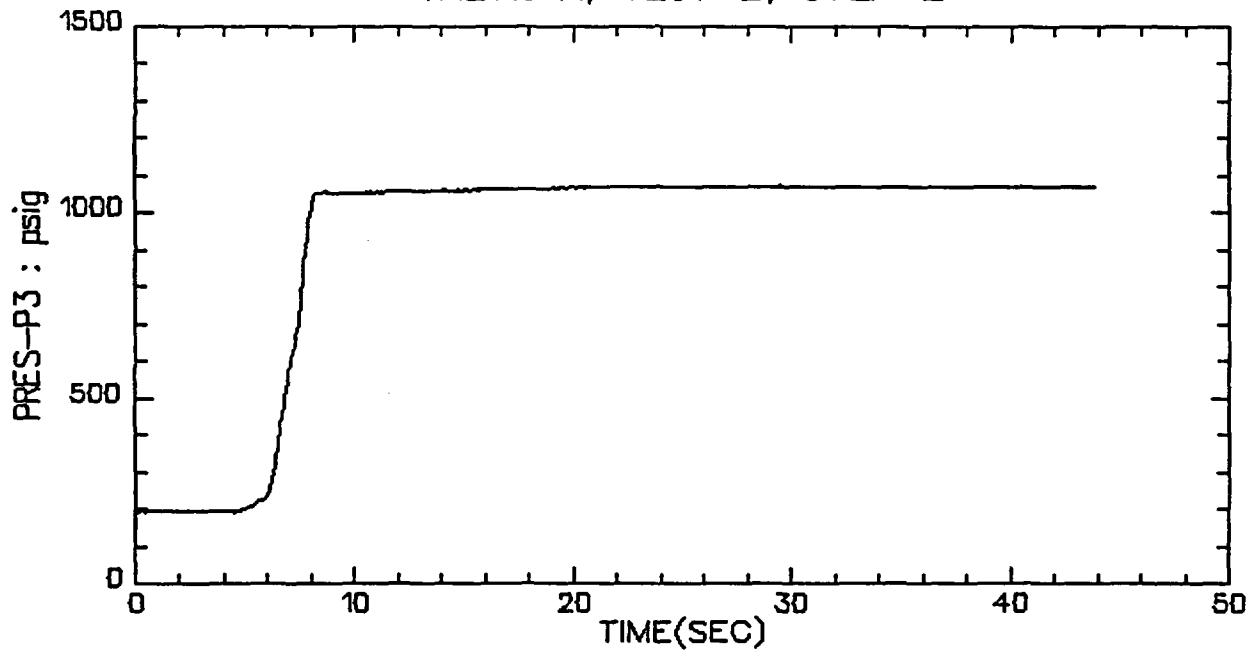

VALVE A, TEST 2, STEP 2

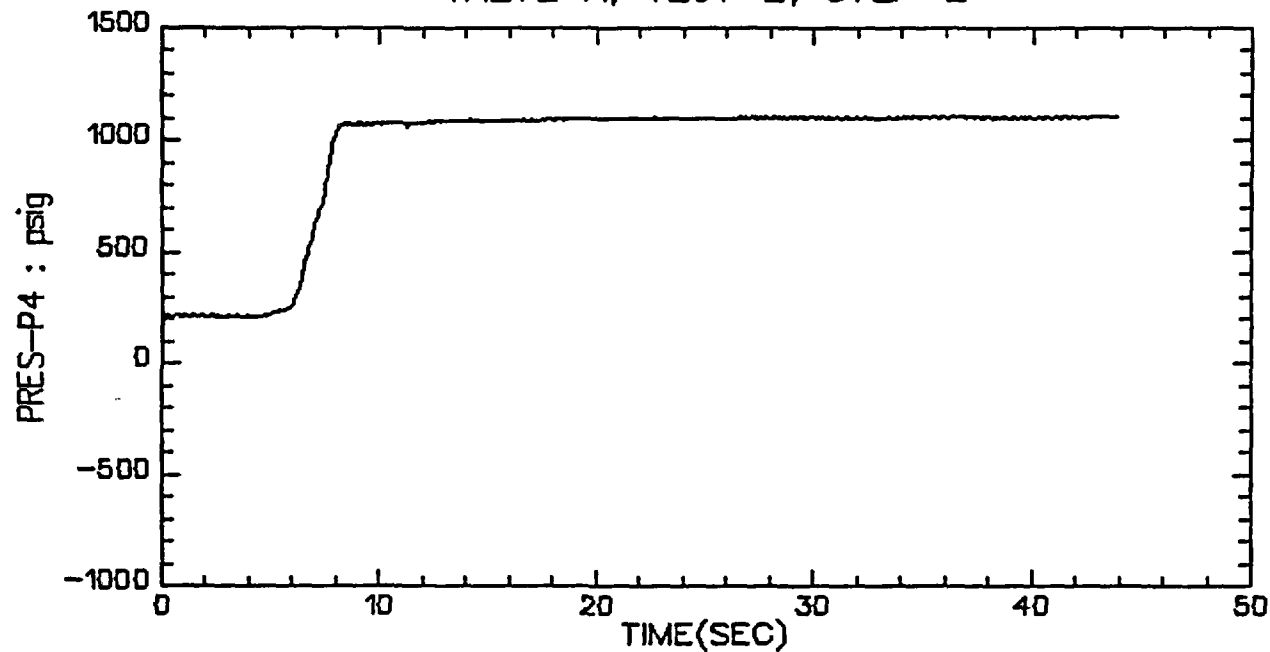

VALVE A, TEST 2, STEP 2

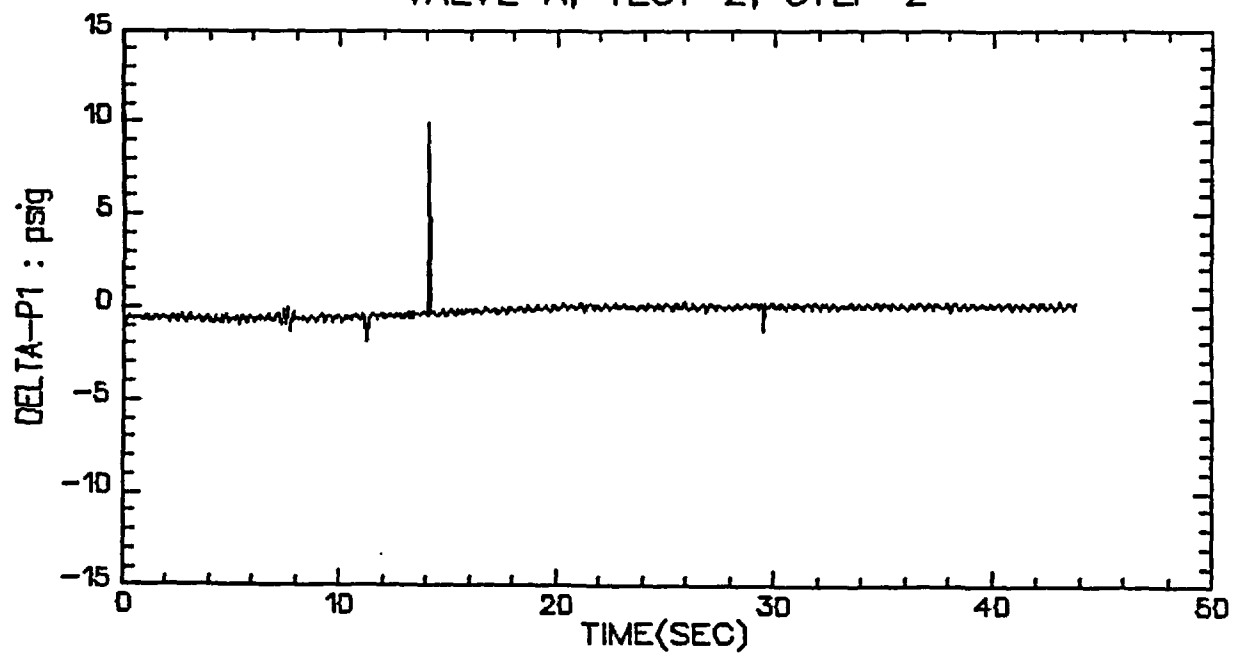

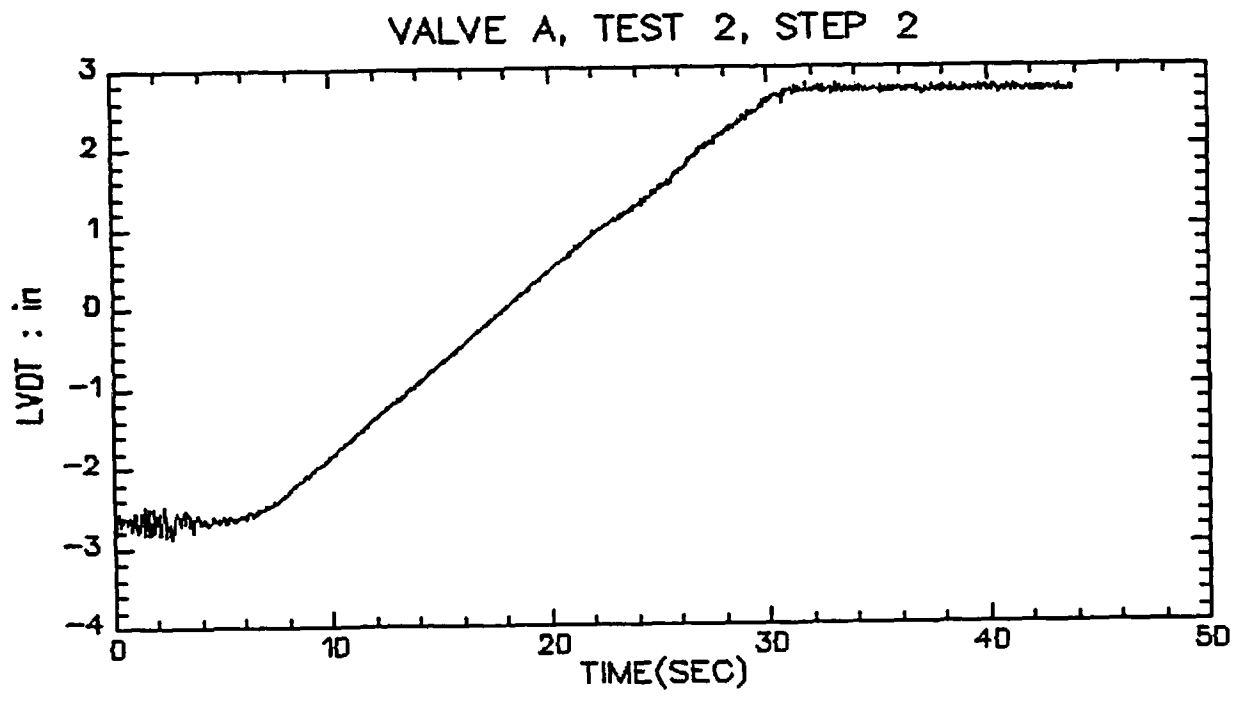
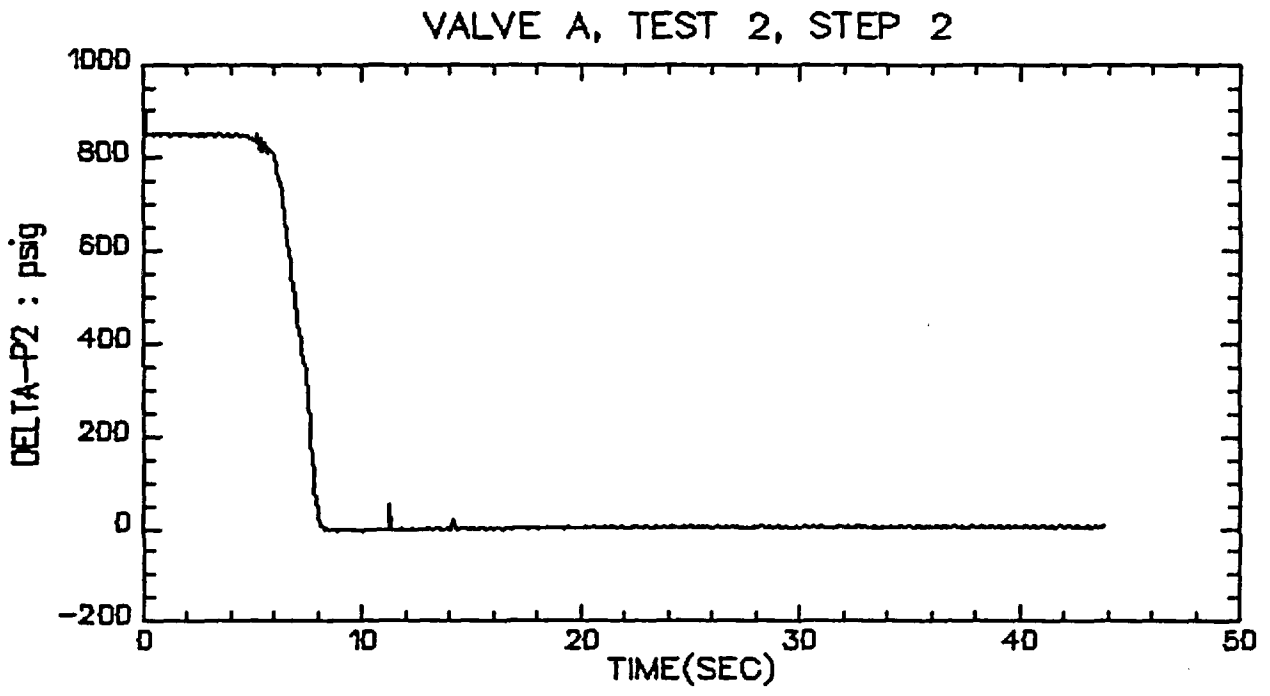

VALVE A, TEST 2, STEP 2

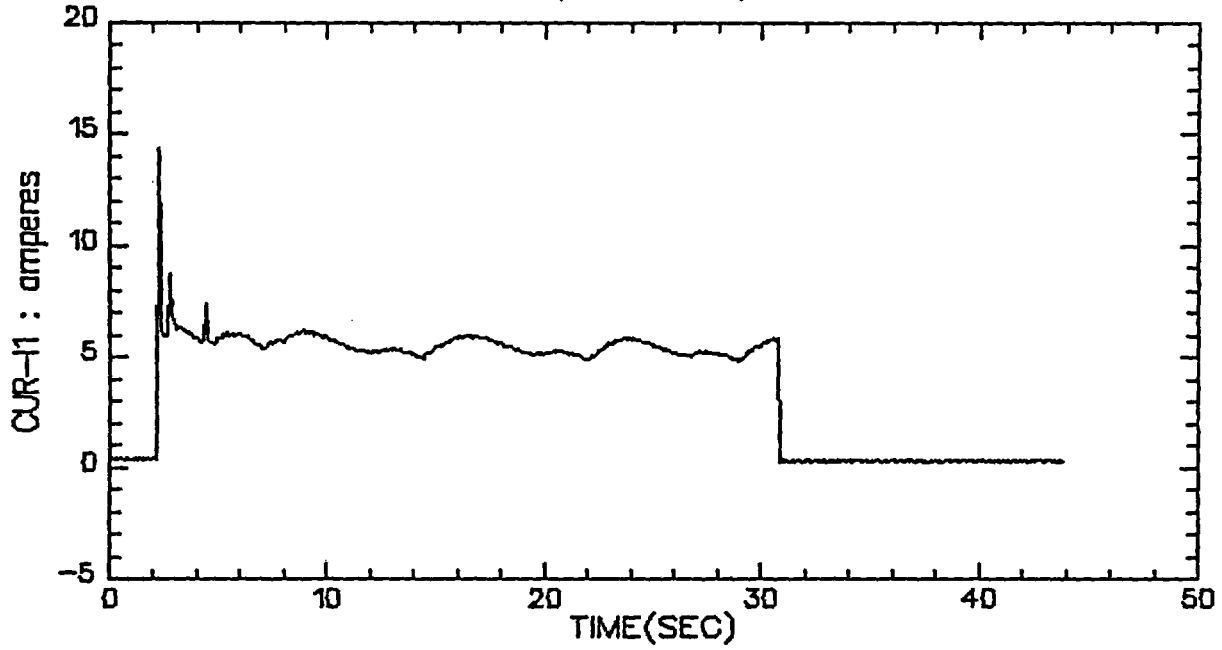

VALVE A, TEST 2, STEP 2

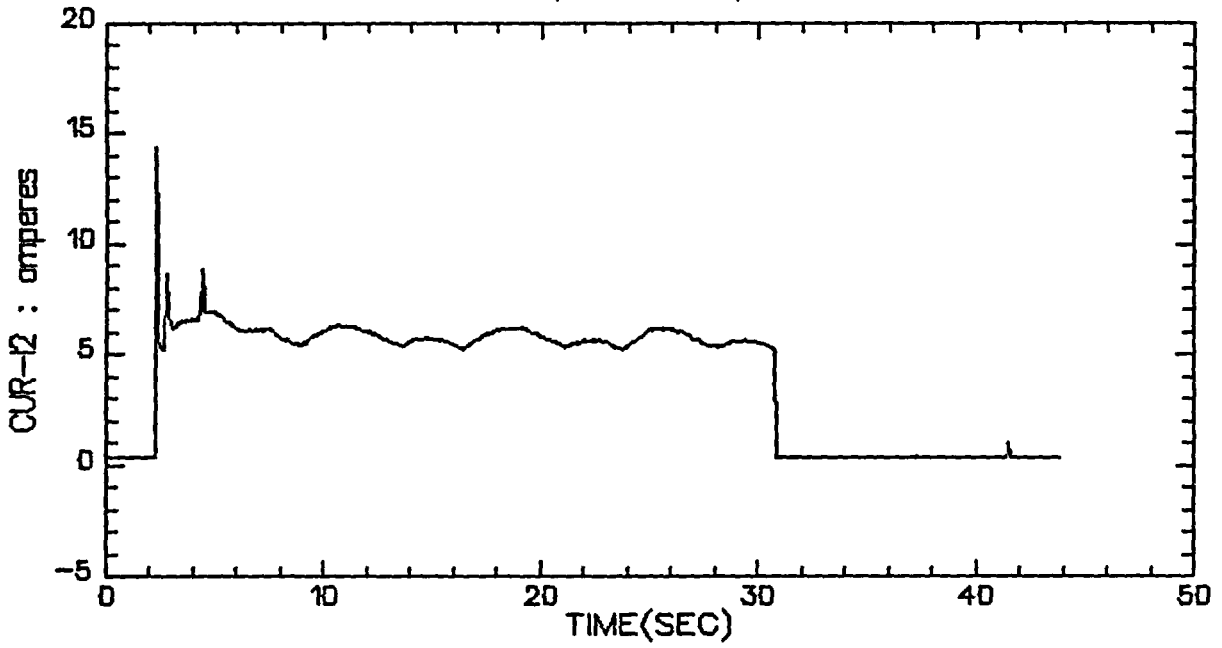

VALVE A, TEST 2, STEP 2

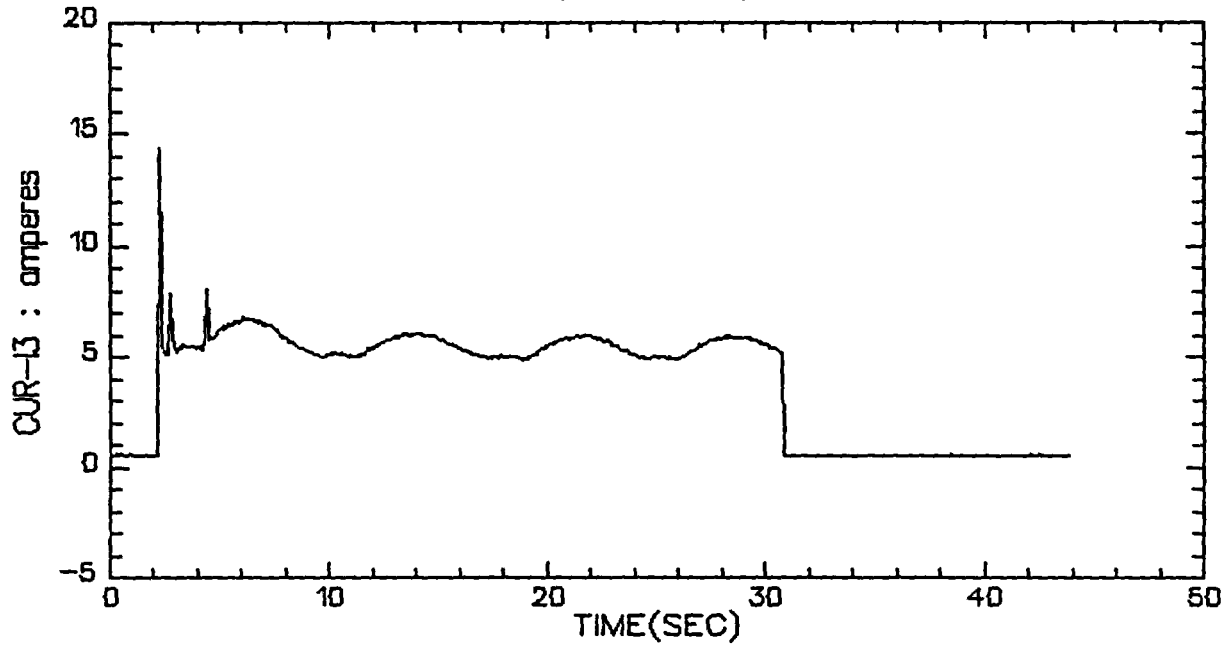

VALVE A, TEST 2, STEP 2

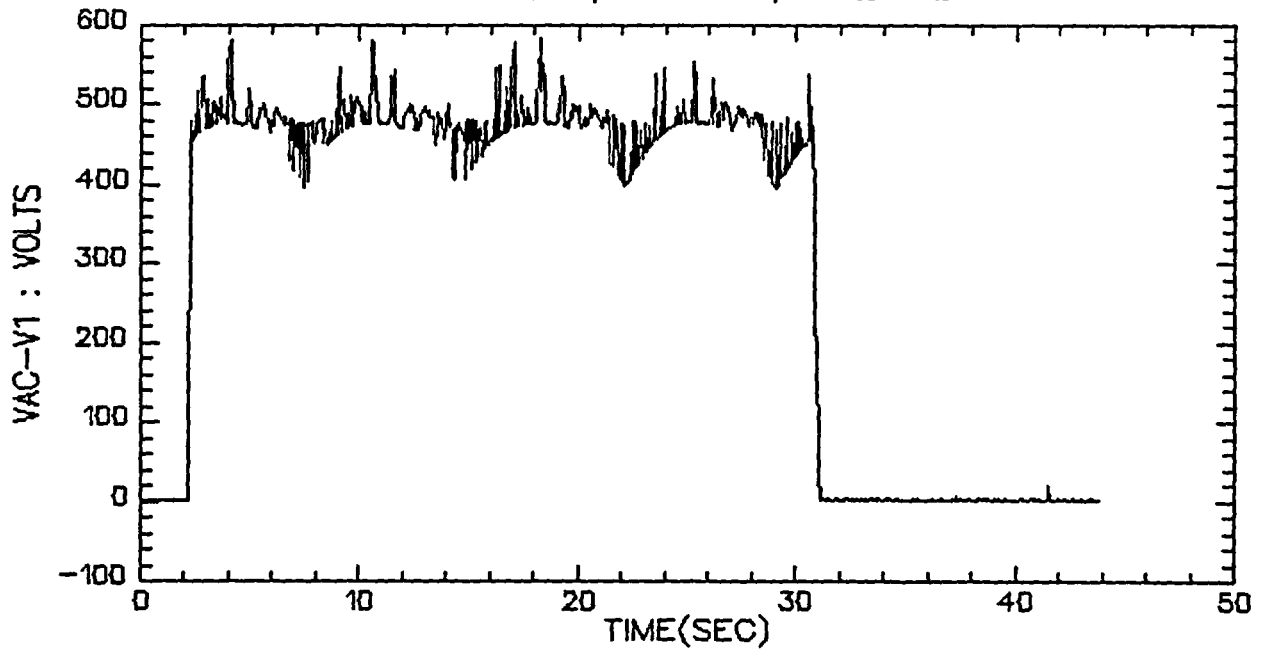

VALVE A, TEST 2, STEP 2

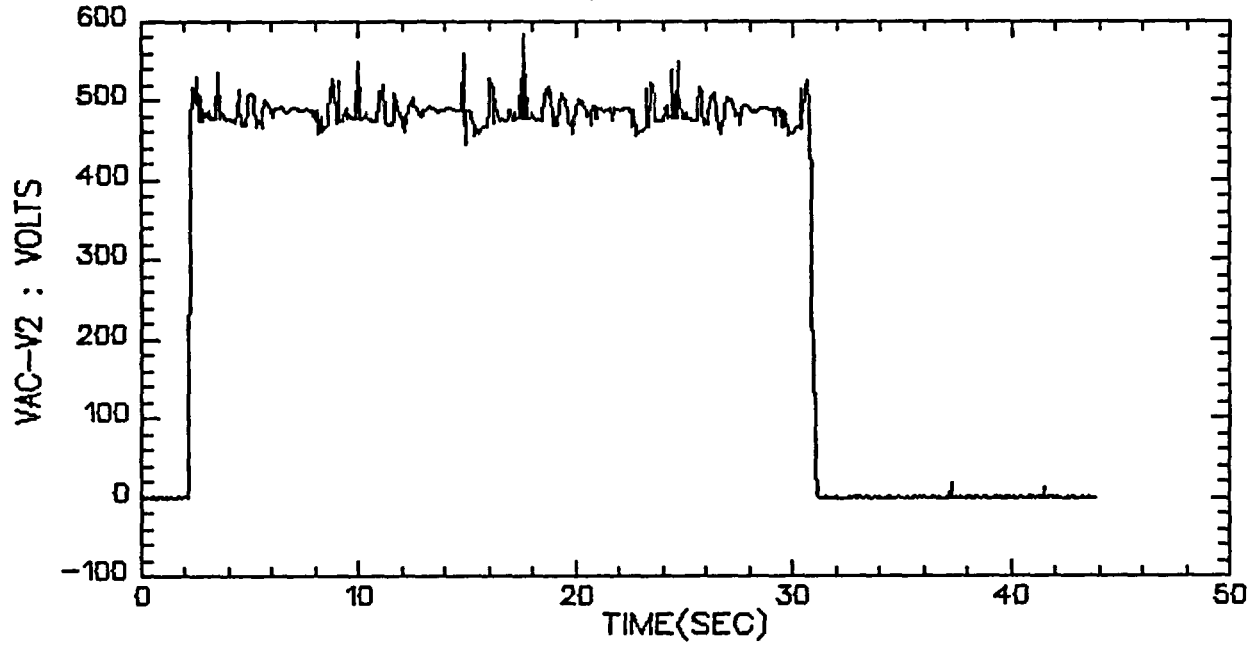

VALVE A, TEST 2, STEP 2

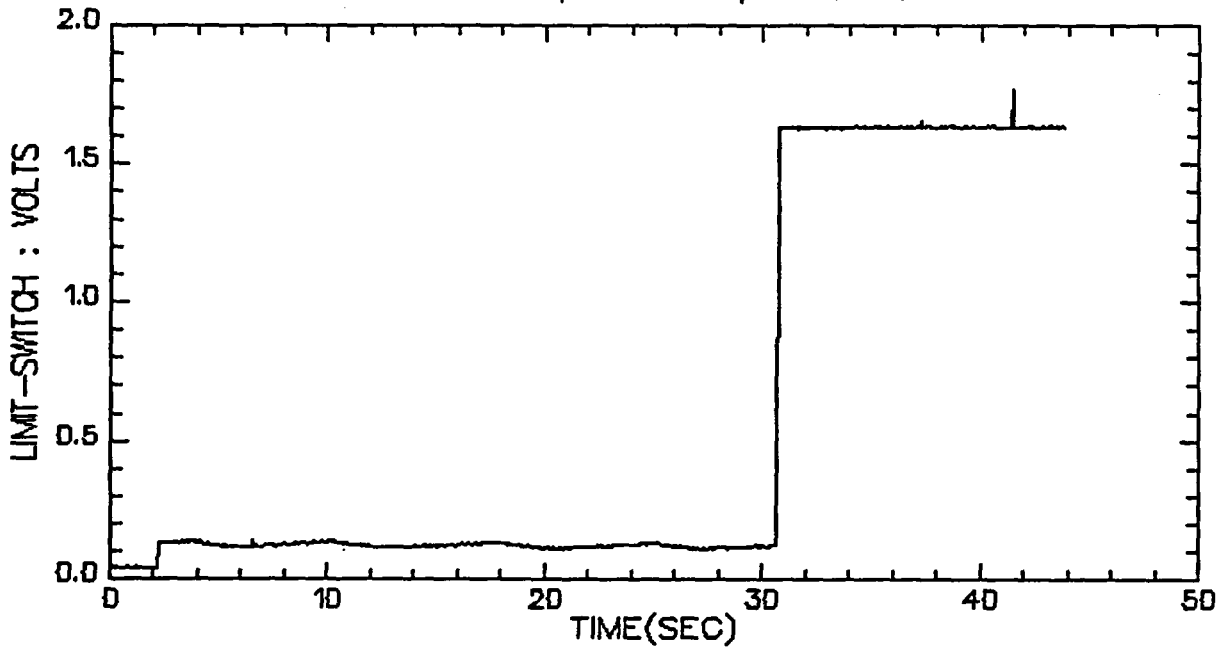

VALVE A, TEST 2, STEP 2

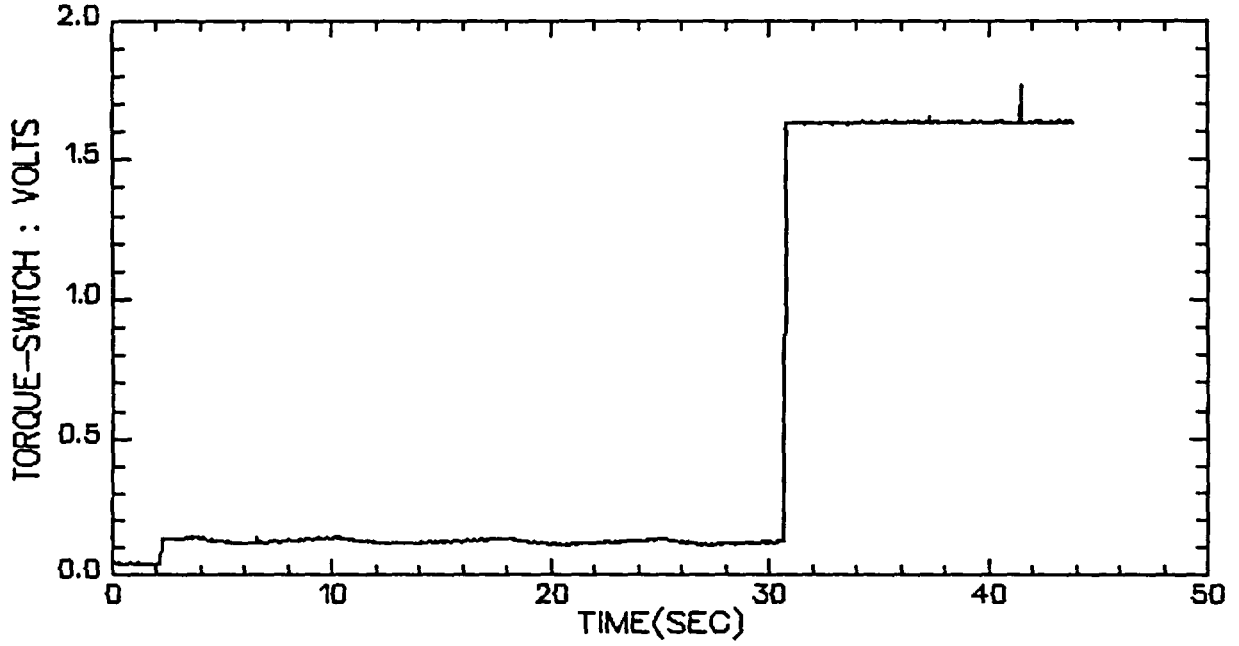

VALVE A, TEST 2, STEP 2

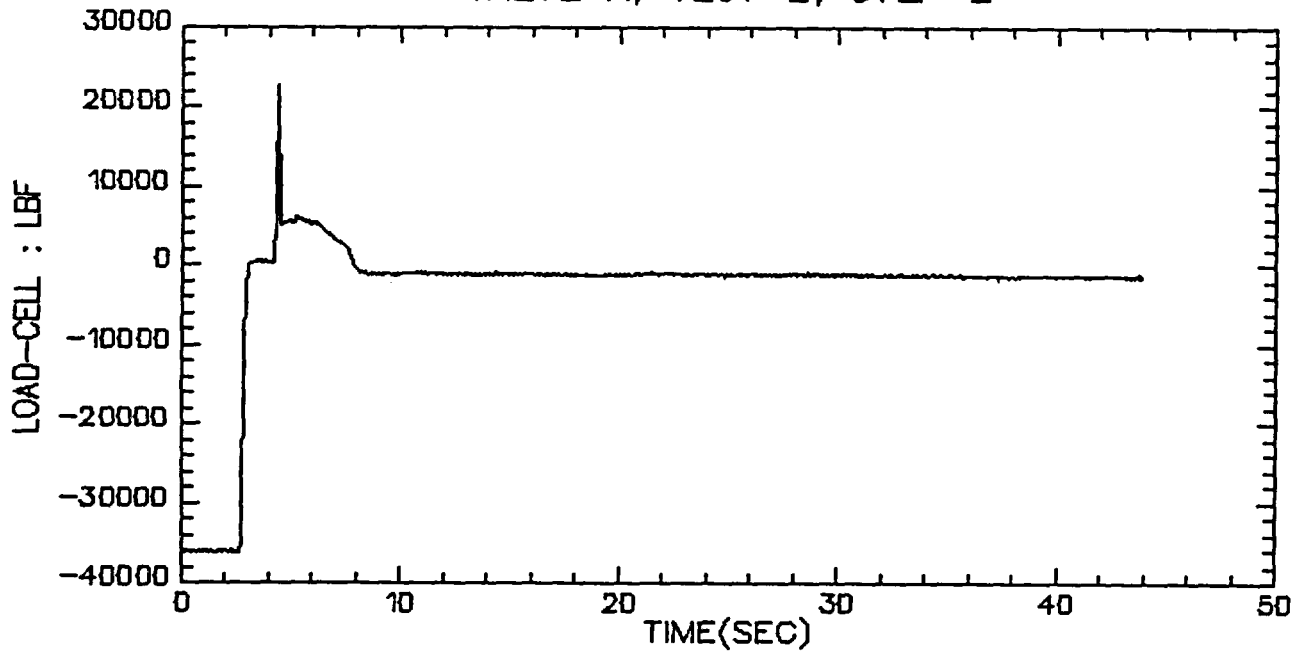

VALVE A, TEST 2, STEP 3&4

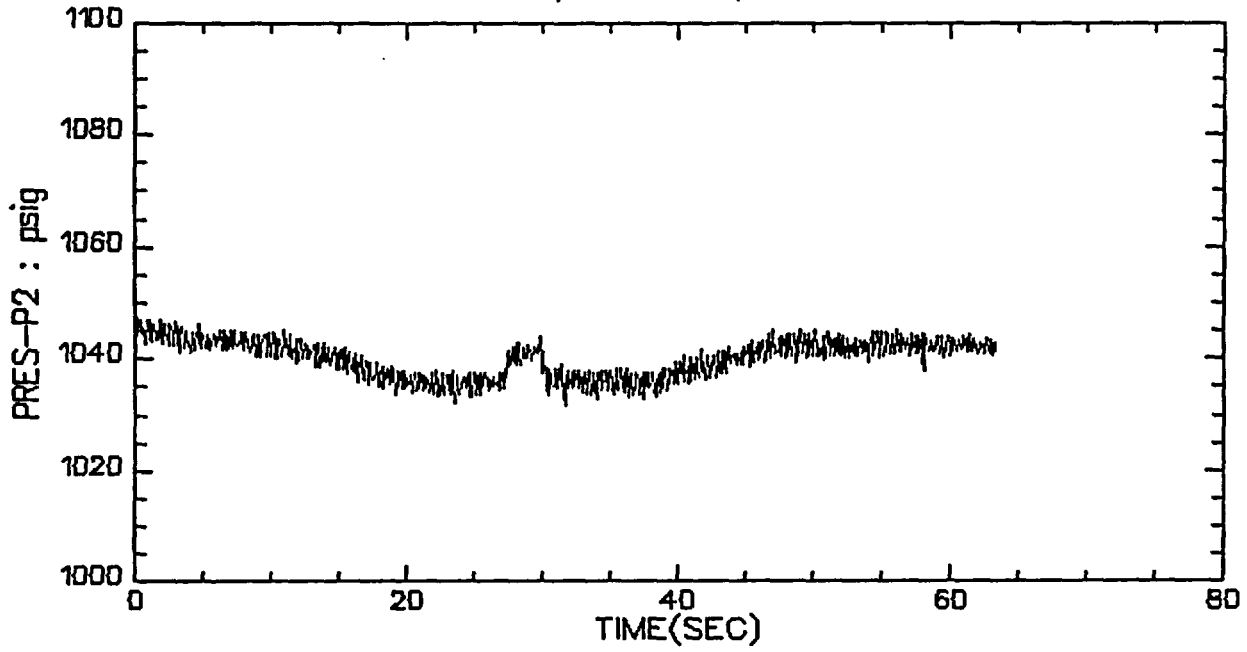

VALVE A, TEST 2, STEP 3&4

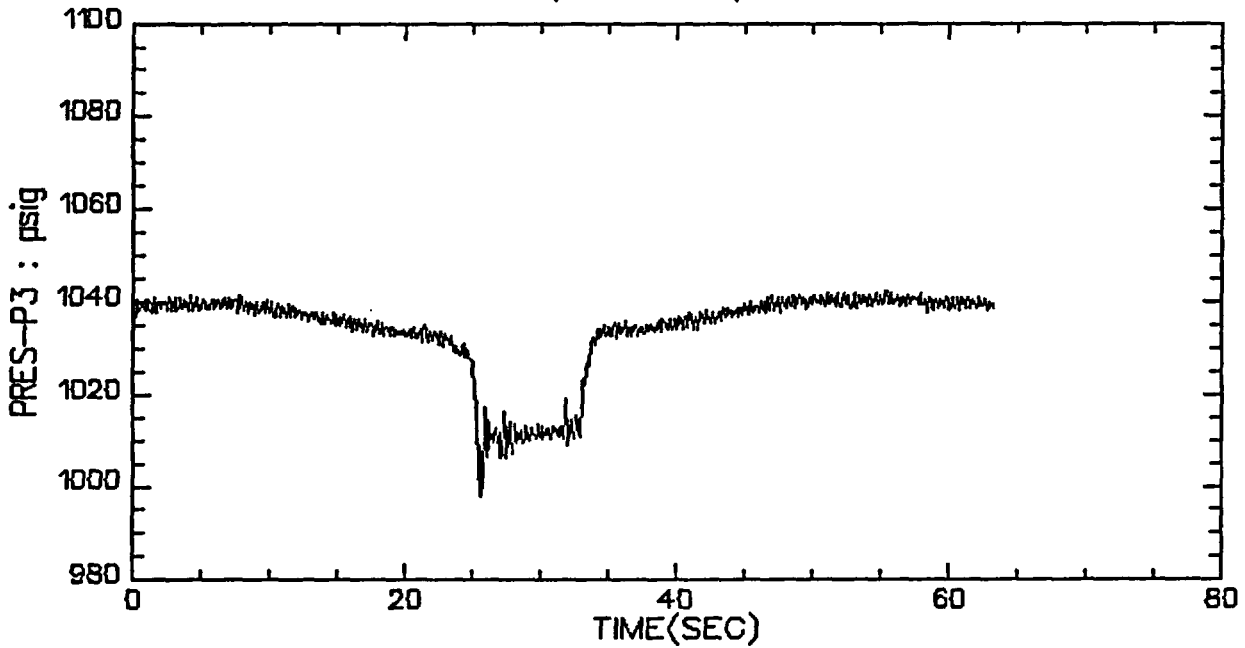

VALVE A, TEST 2, STEP 3&4

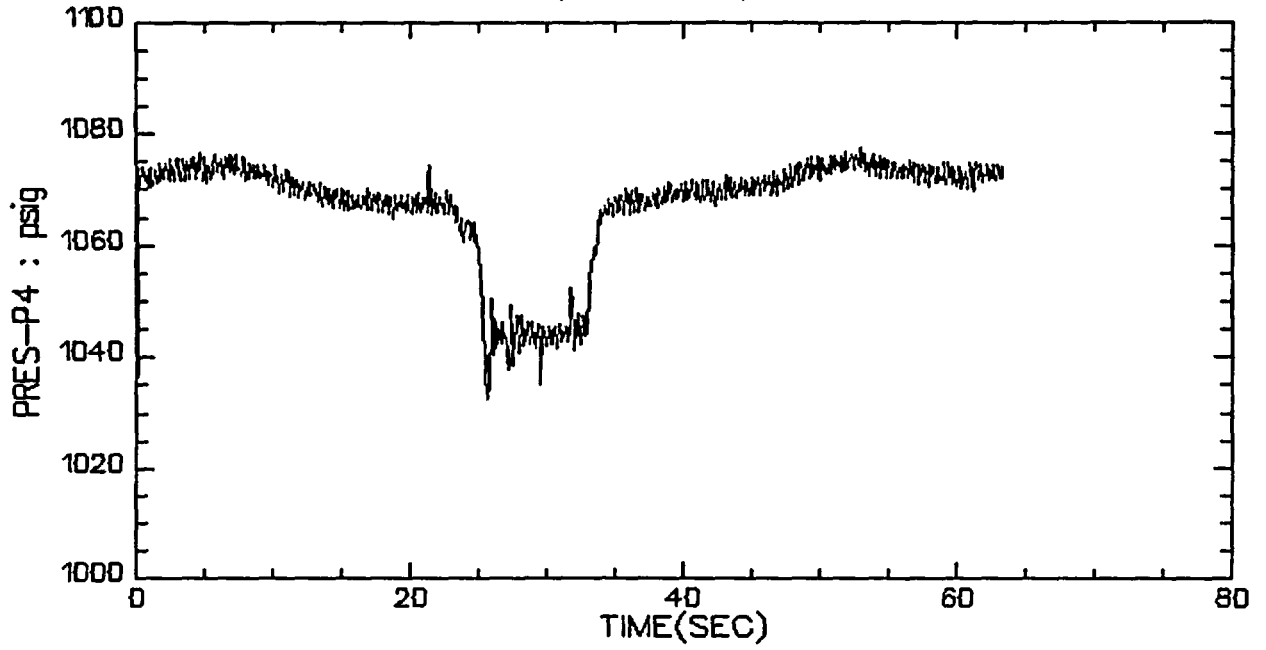

VALVE A, TEST 2, STEP 3&4

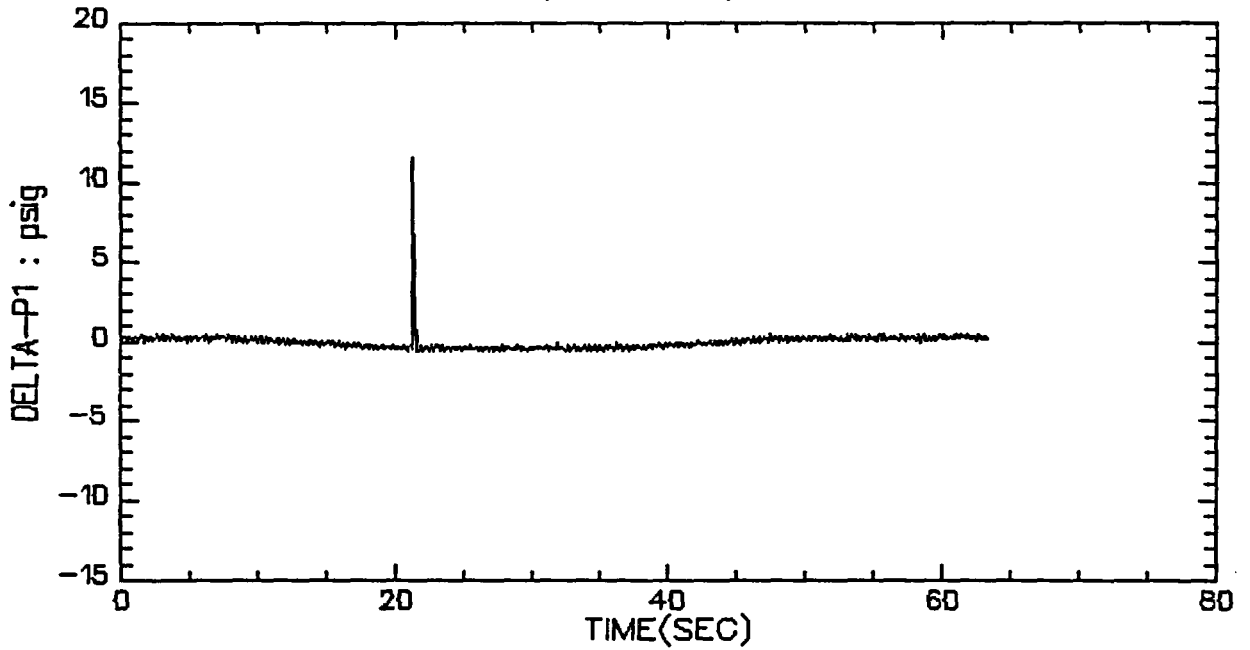

VALVE A, TEST 2, STEP 3&4

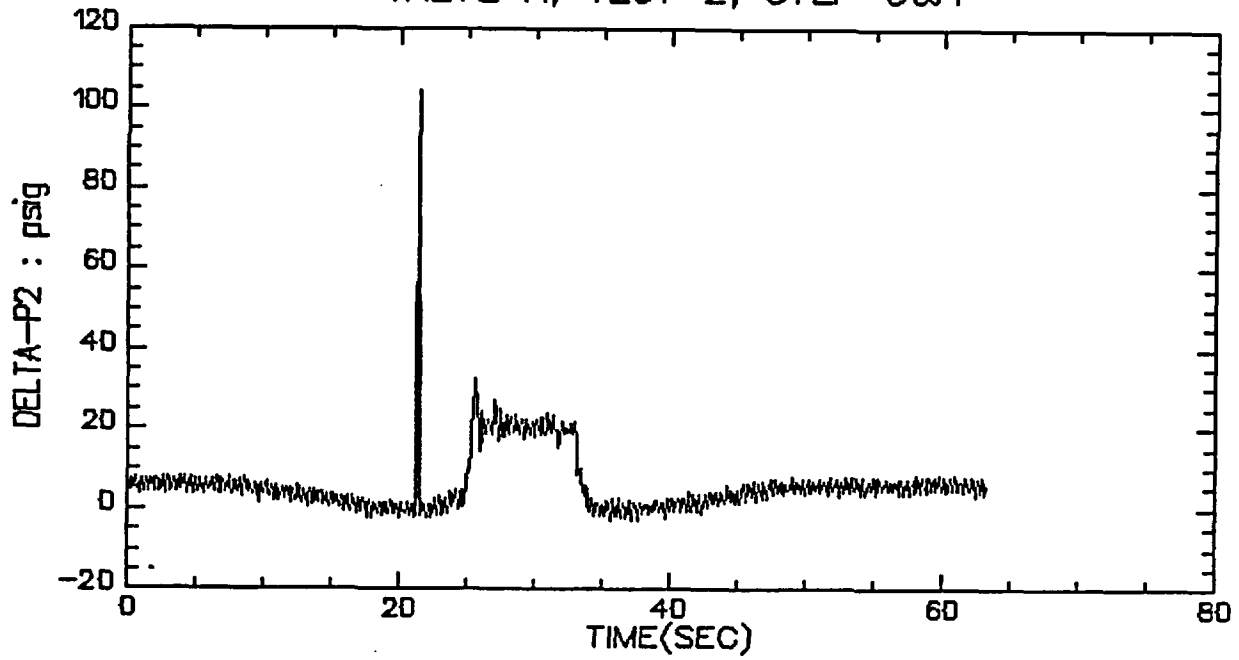

VALVE A, TEST 2, STEP 3&4

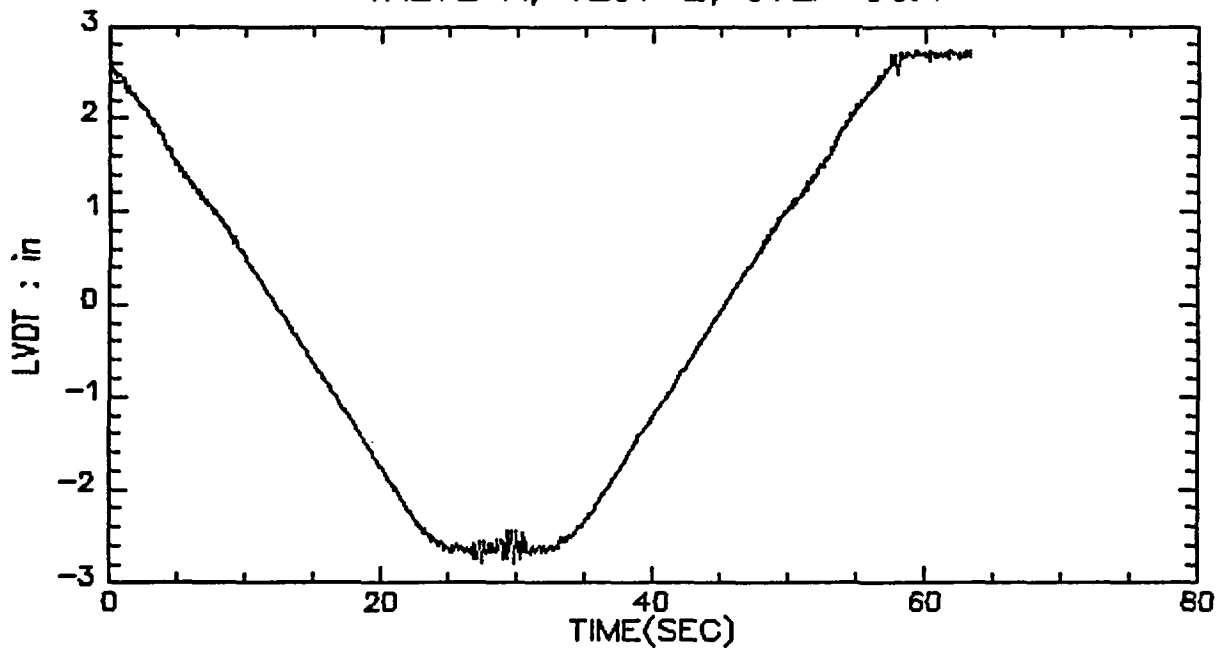

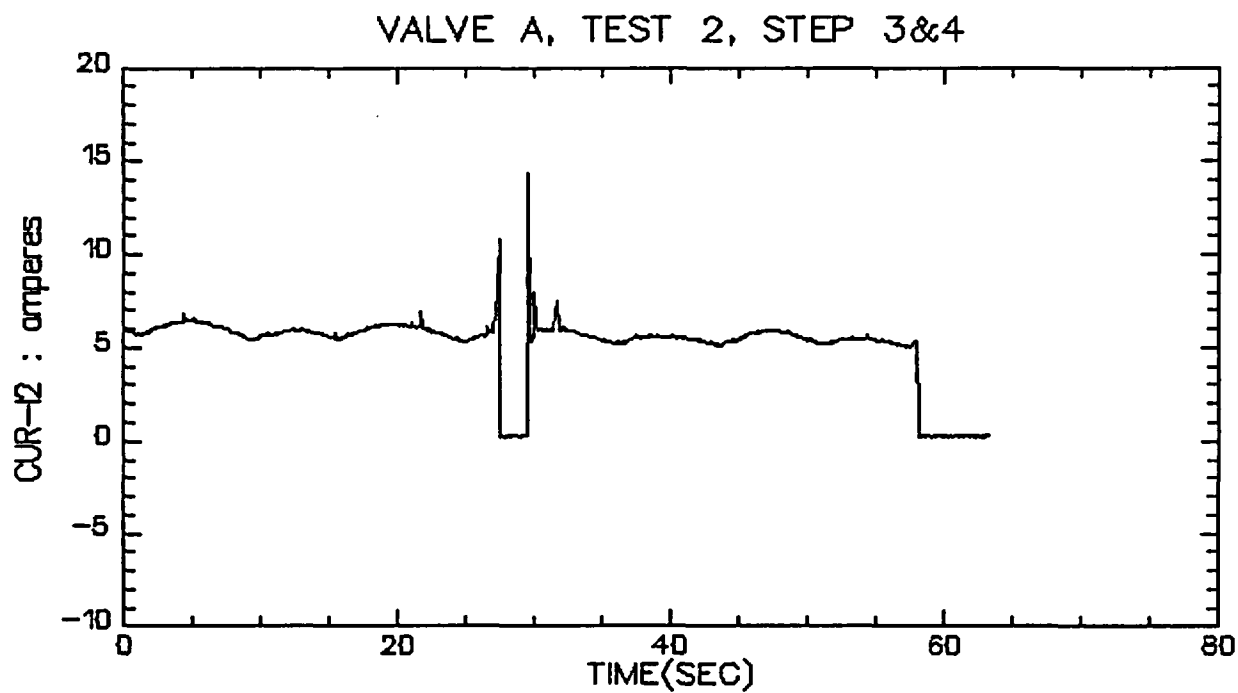
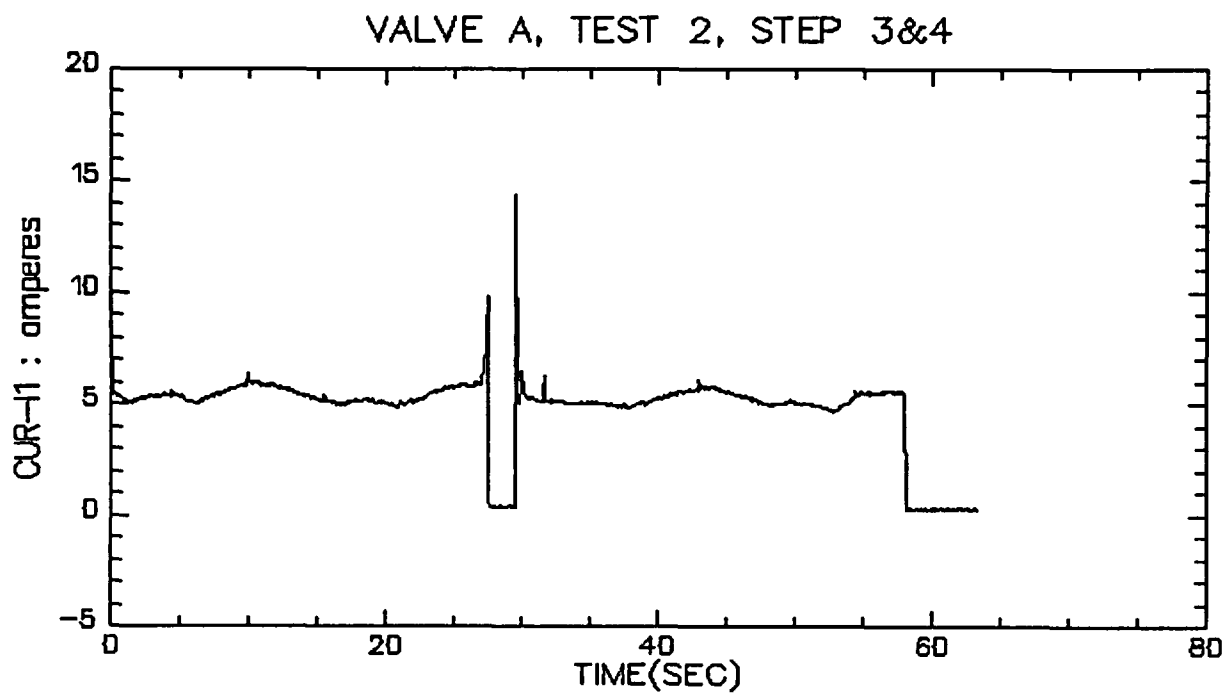

VALVE A, TEST 2, STEP 3&4

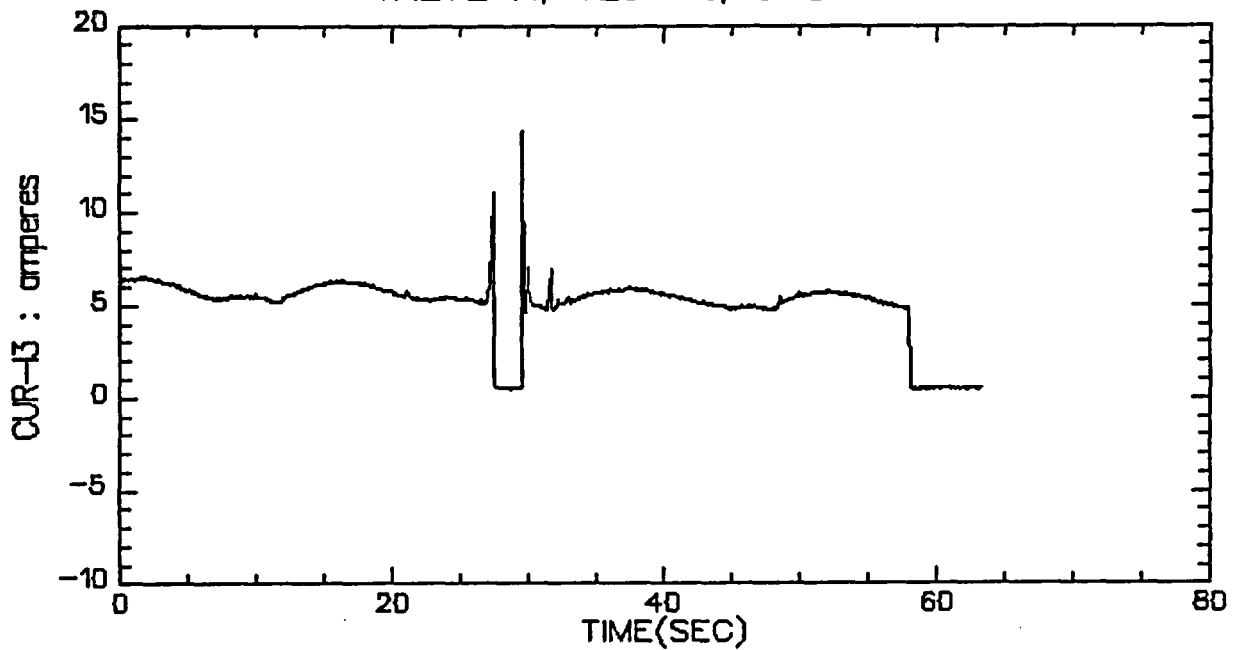

VALVE A, TEST 2, STEP 3&4

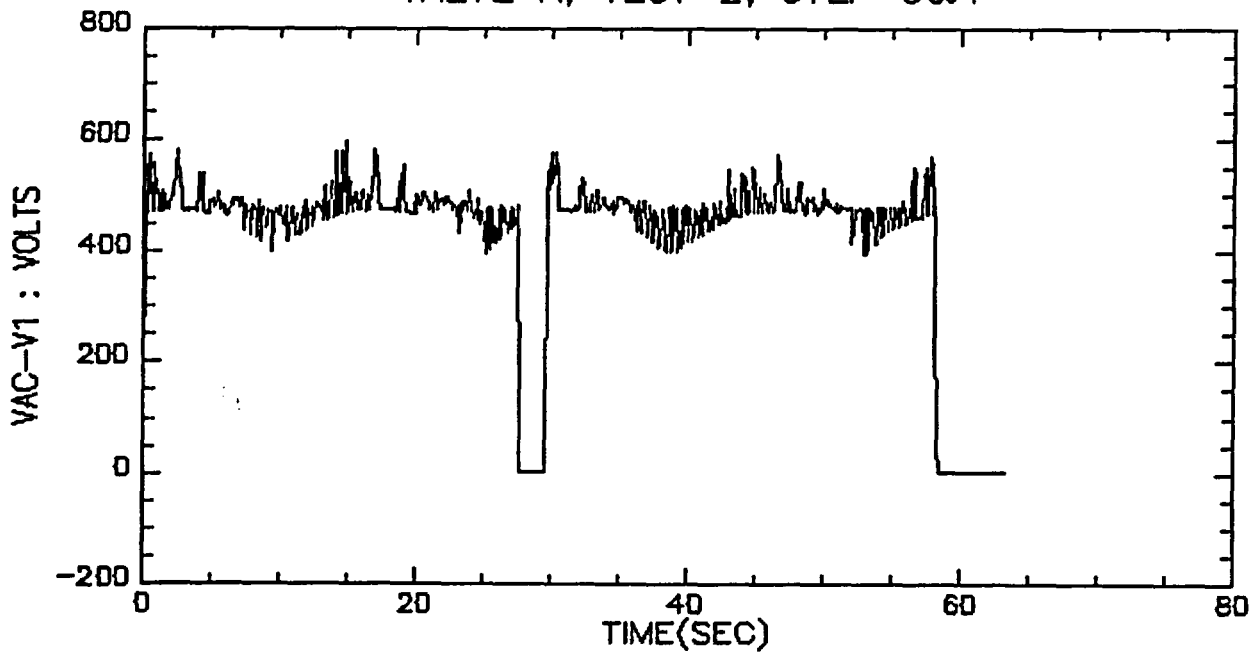

VALVE A, TEST 2, STEP 3&4

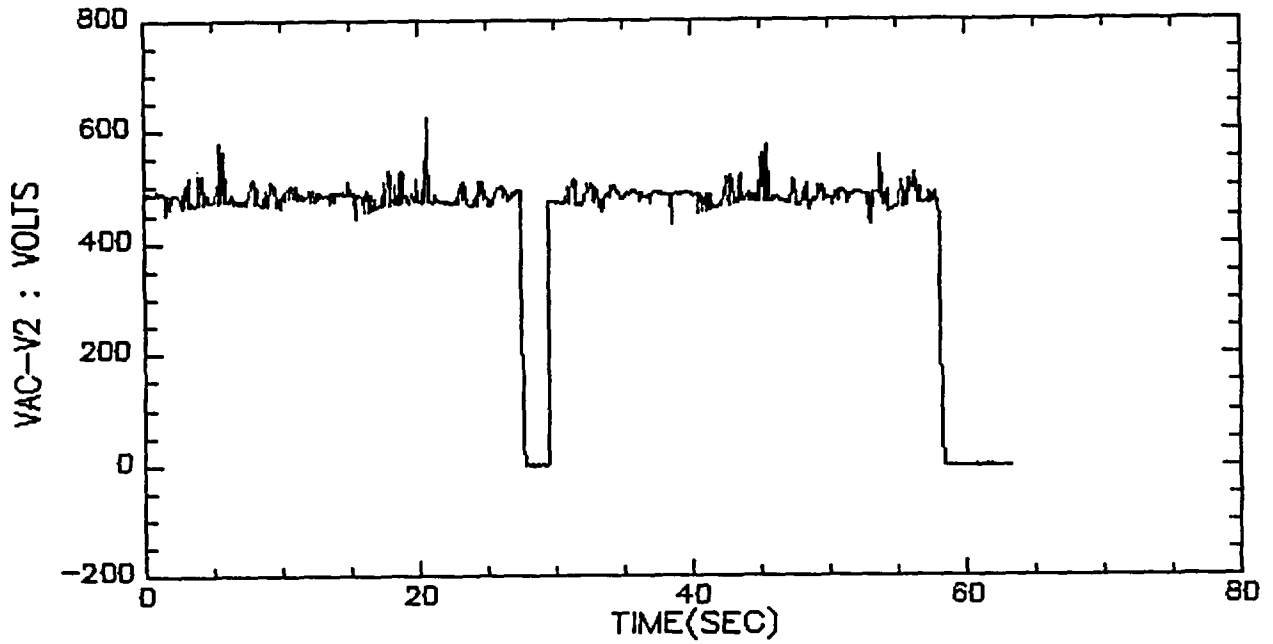

VALVE A, TEST 2, STEP 3&4

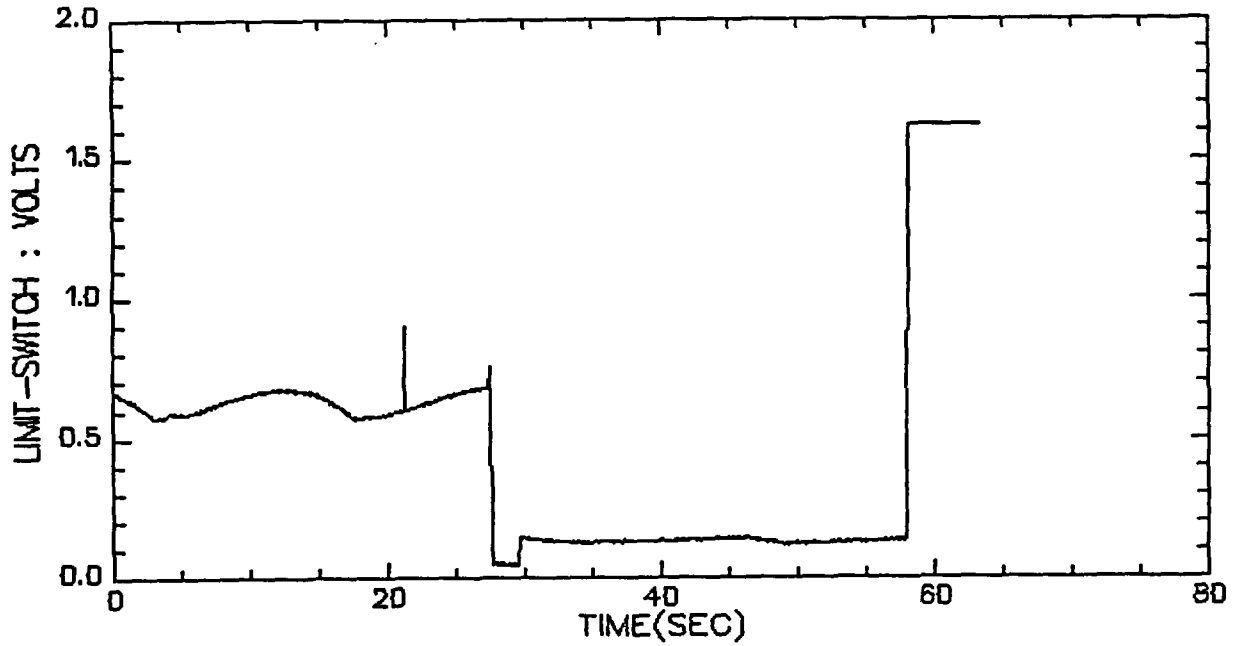

VALVE A, TEST 2, STEP 3&4

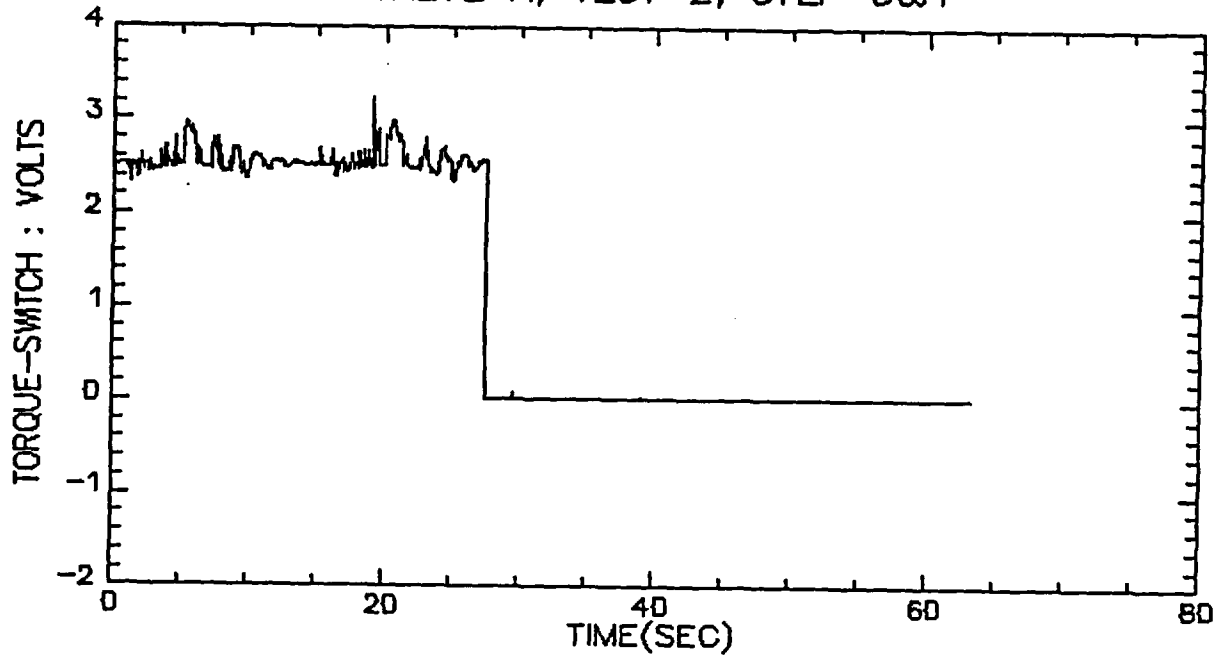

VALVE A, TEST 2, STEP 3&4

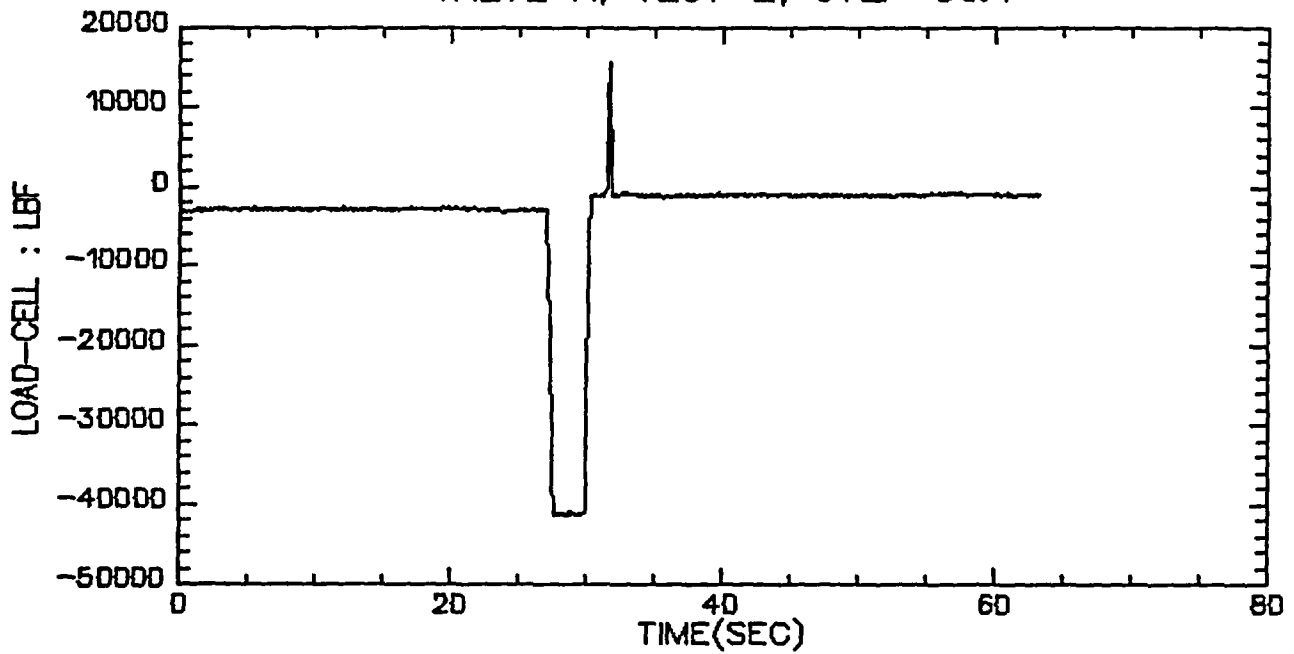

VALVE A, TEST 2, STEP 5

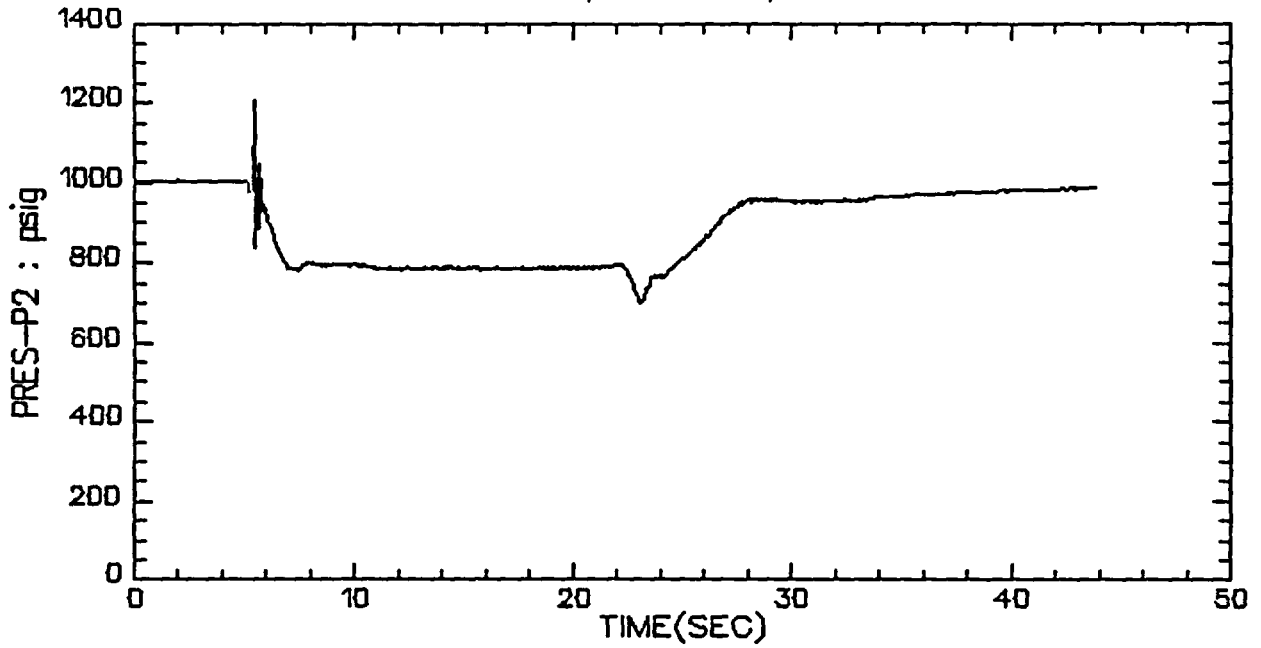

VALVE A, TEST 2, STEP 5

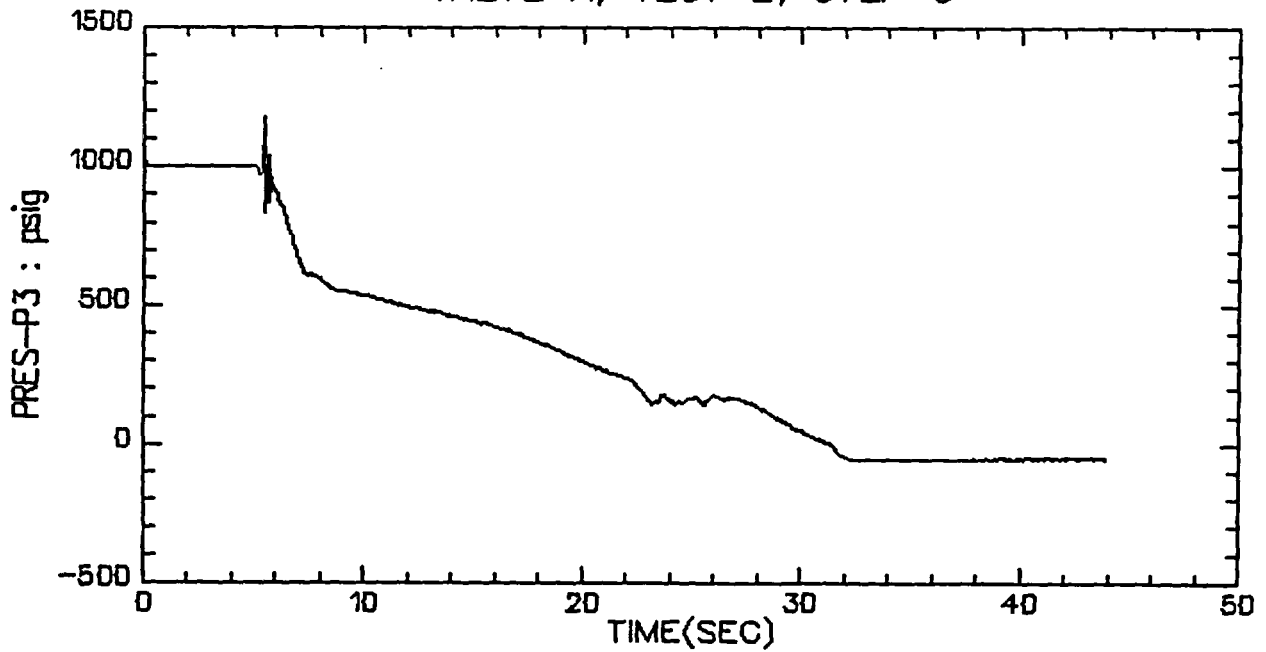

VALVE A, TEST 2, STEP 5

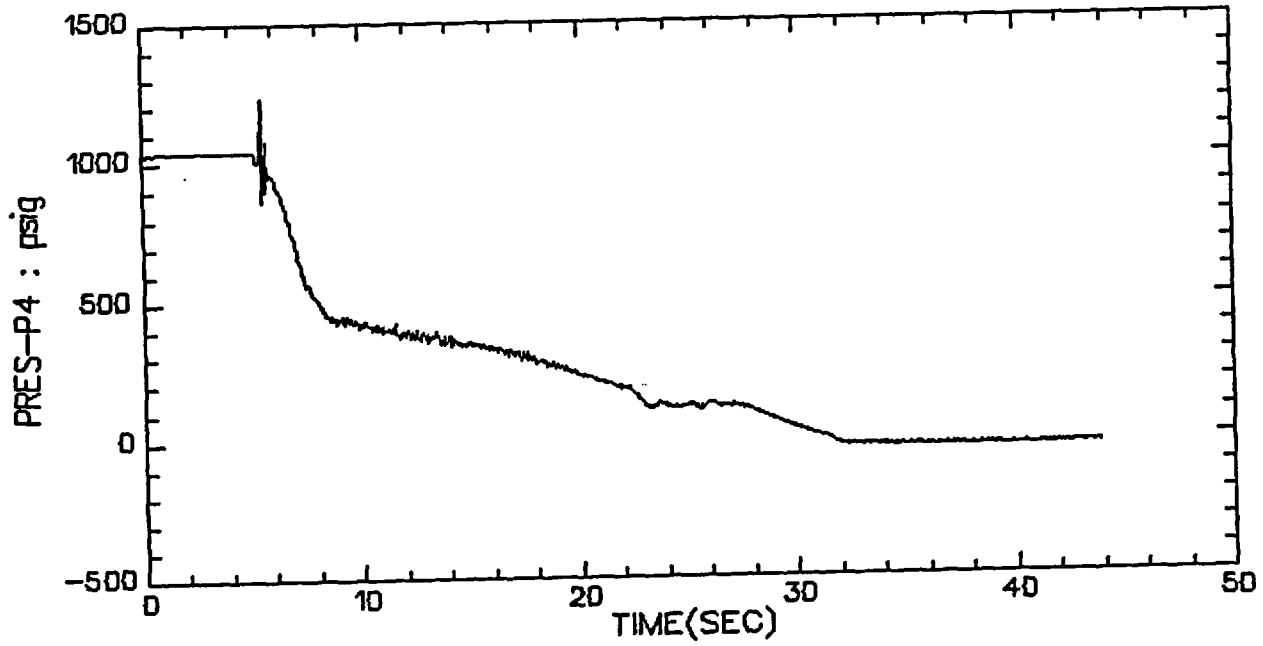

VALVE A, TEST 2, STEP 5

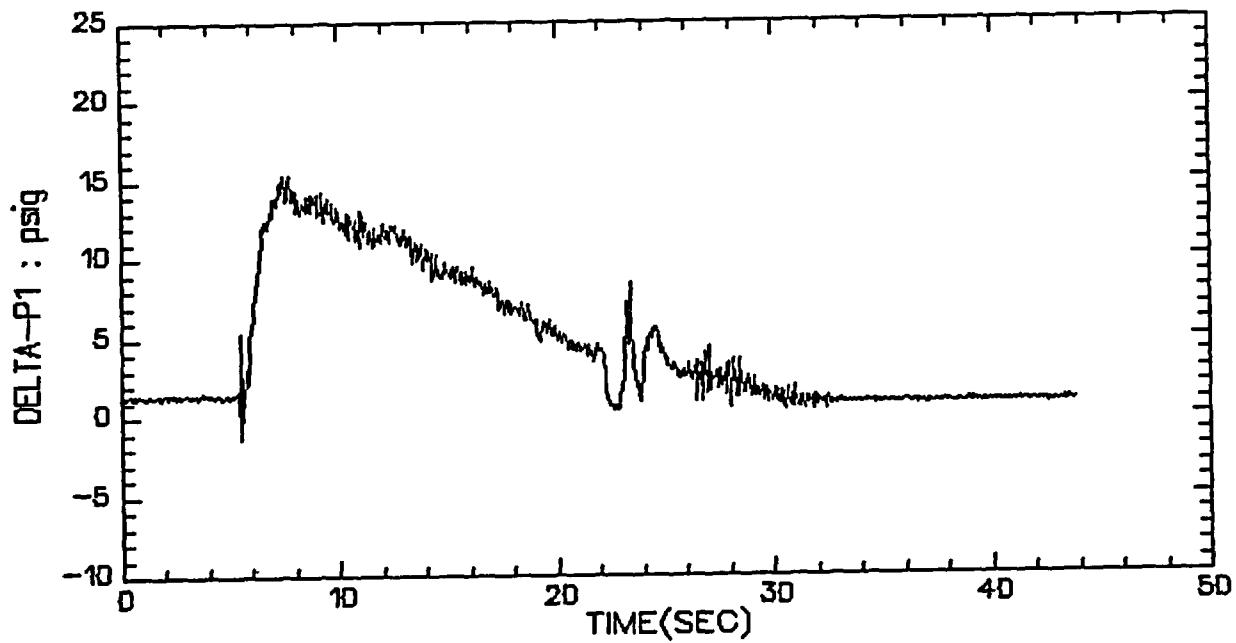

VALVE A, TEST 2, STEP 5

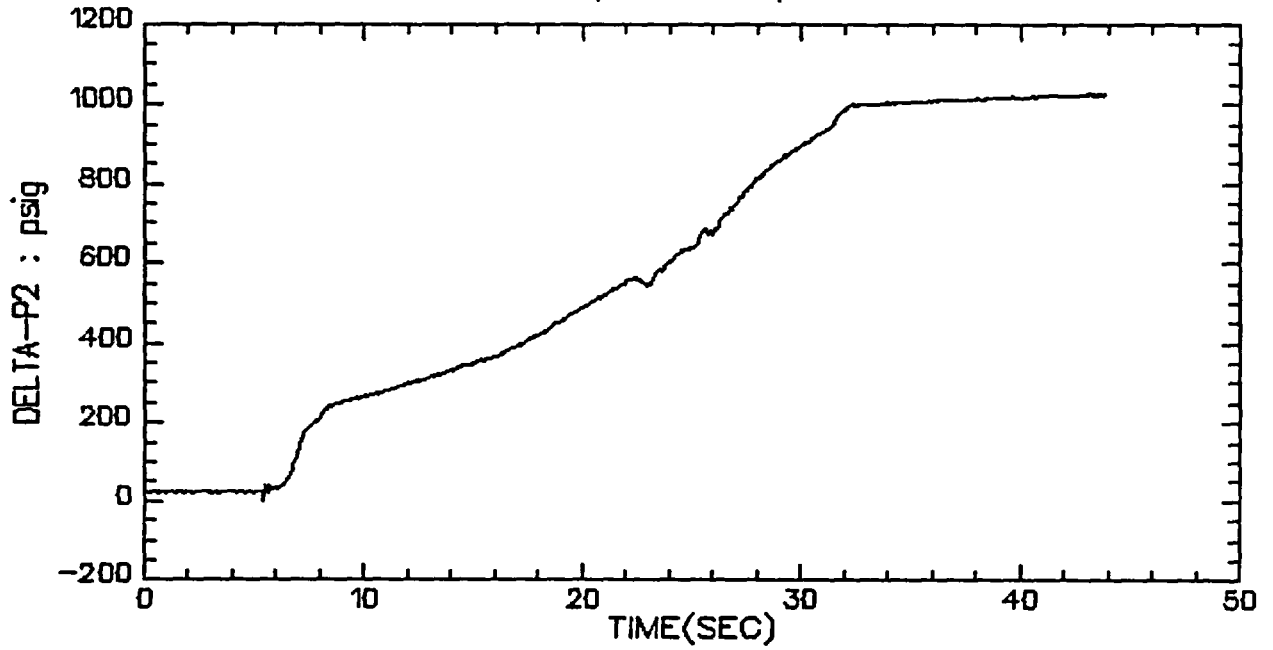

VALVE A, TEST 2, STEP 5

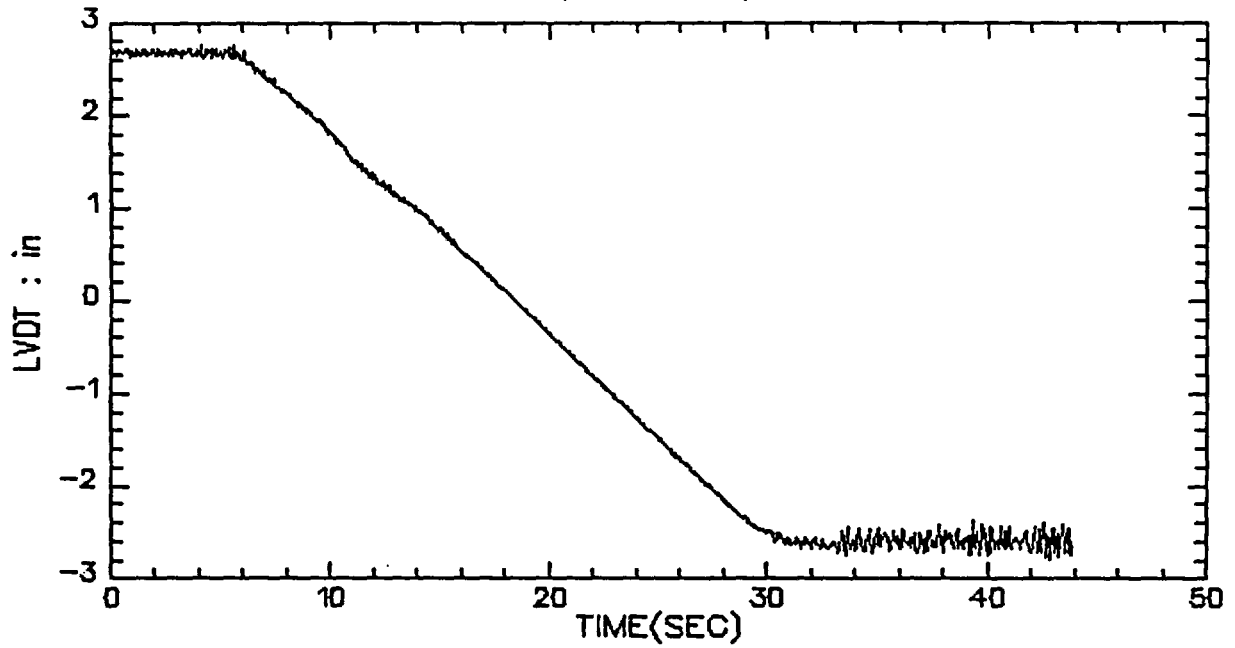

VALVE A, TEST 2, STEP 5

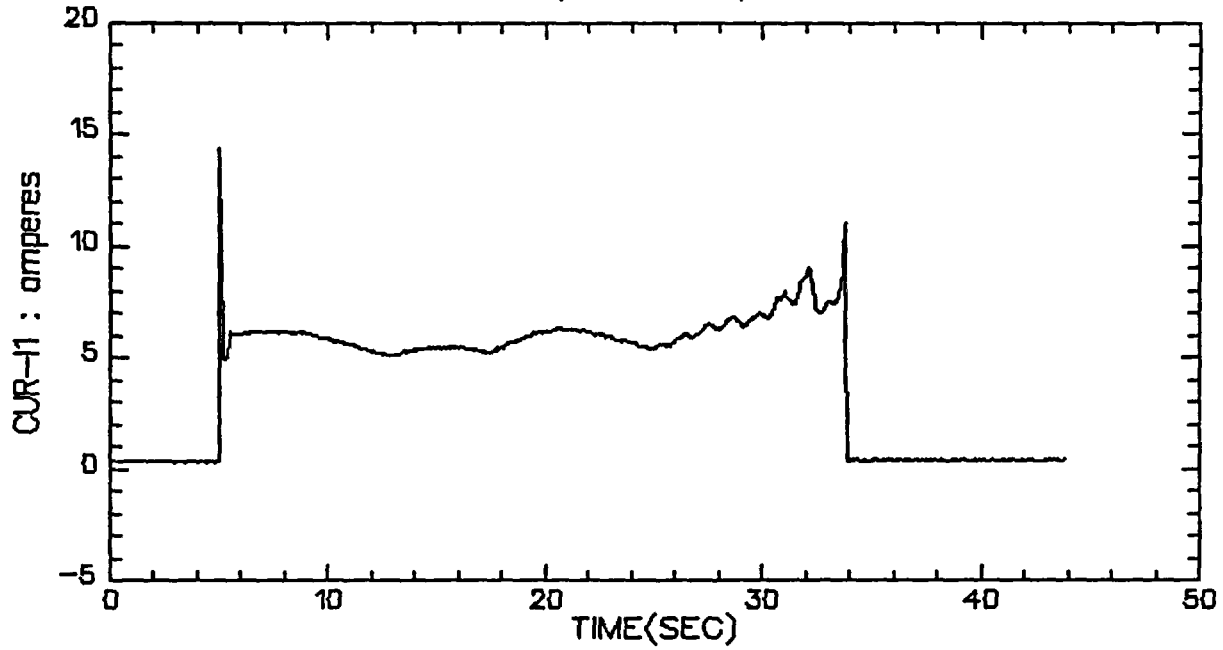

VALVE A, TEST 2, STEP 5

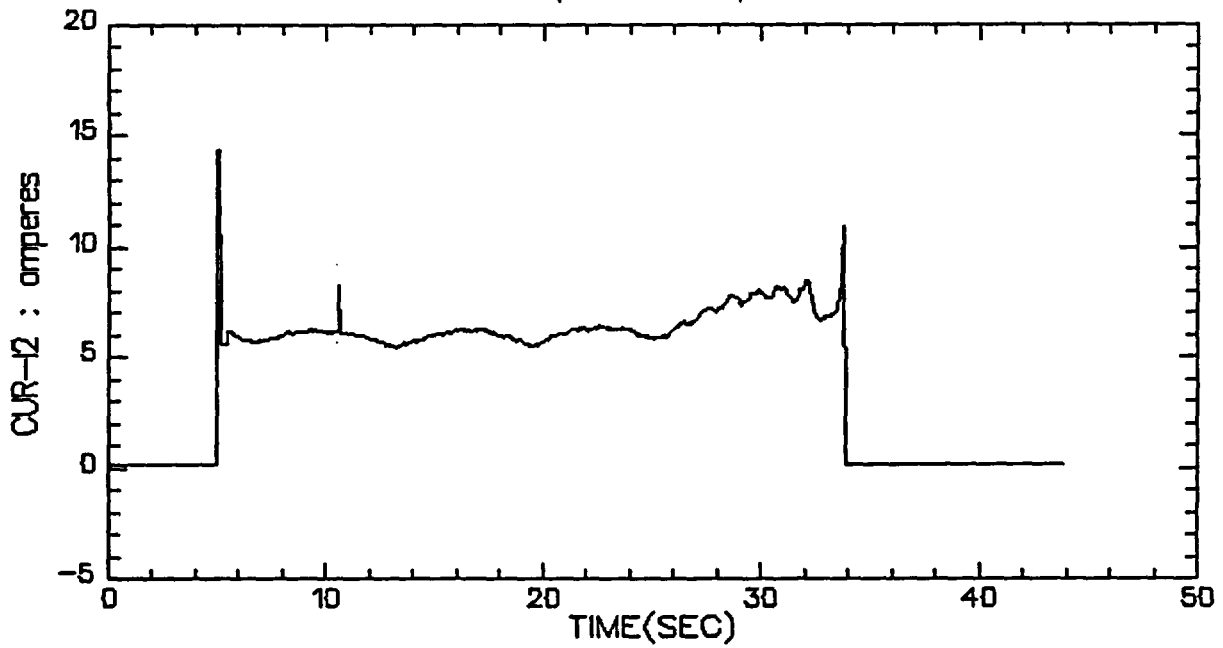

VALVE A, TEST 2, STEP 5

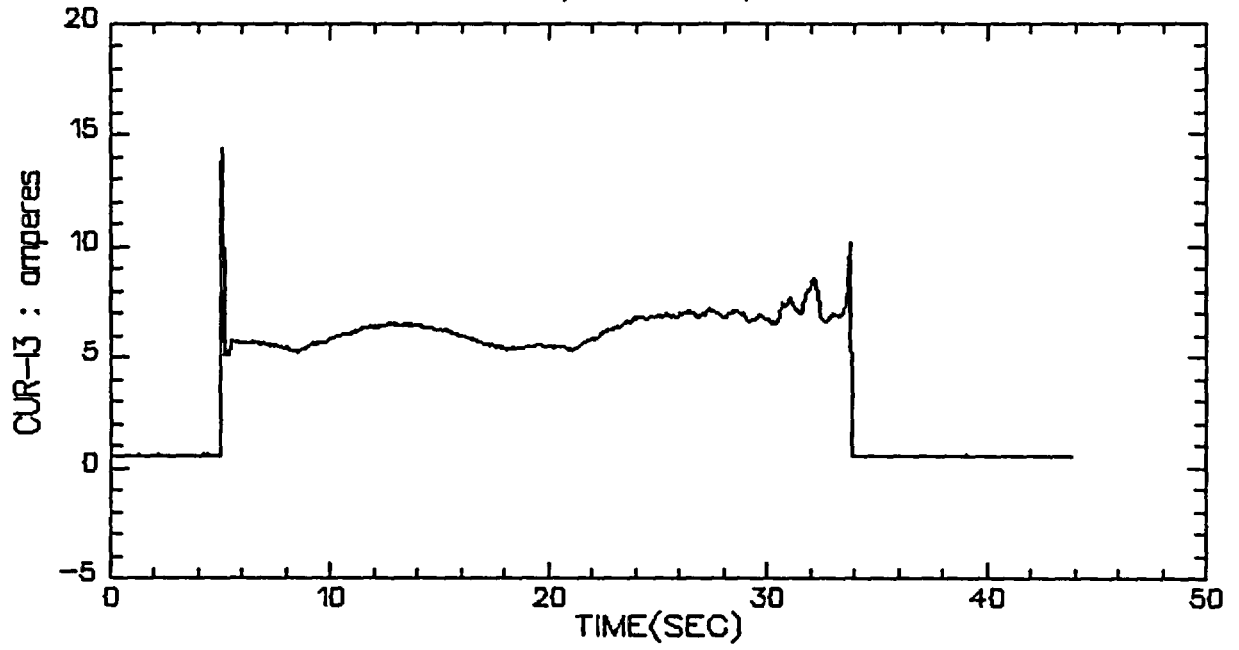

VALVE A, TEST 2, STEP 5

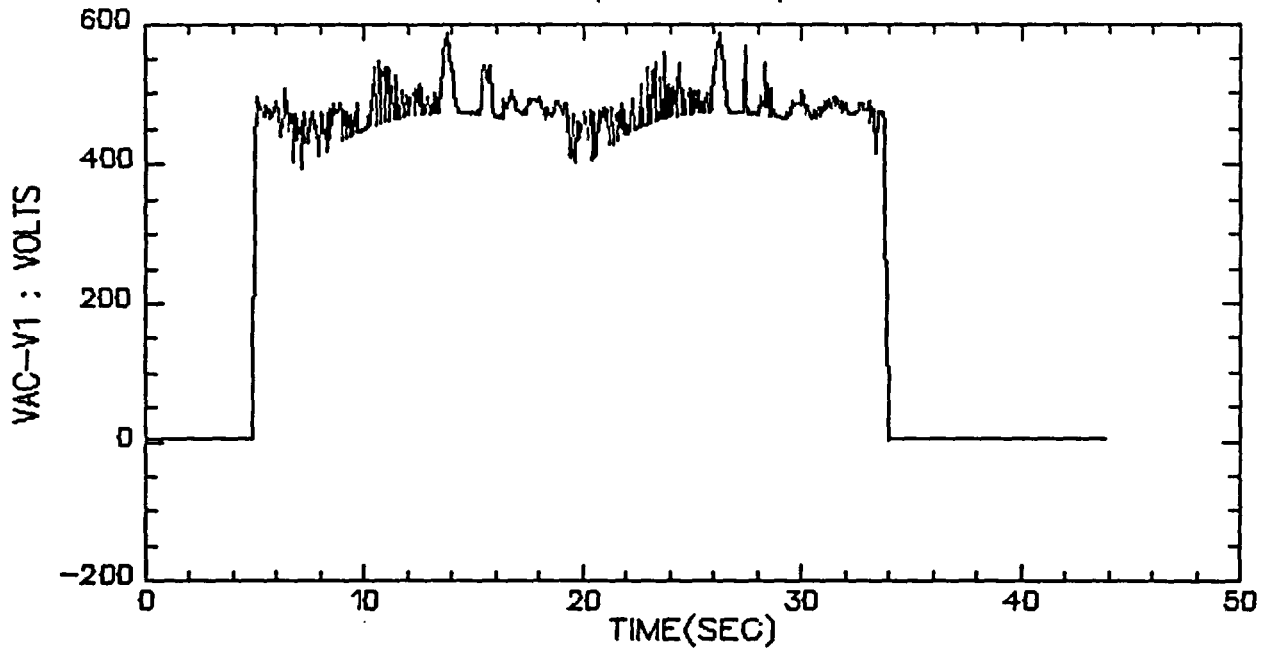

VALVE A, TEST 2, STEP 5

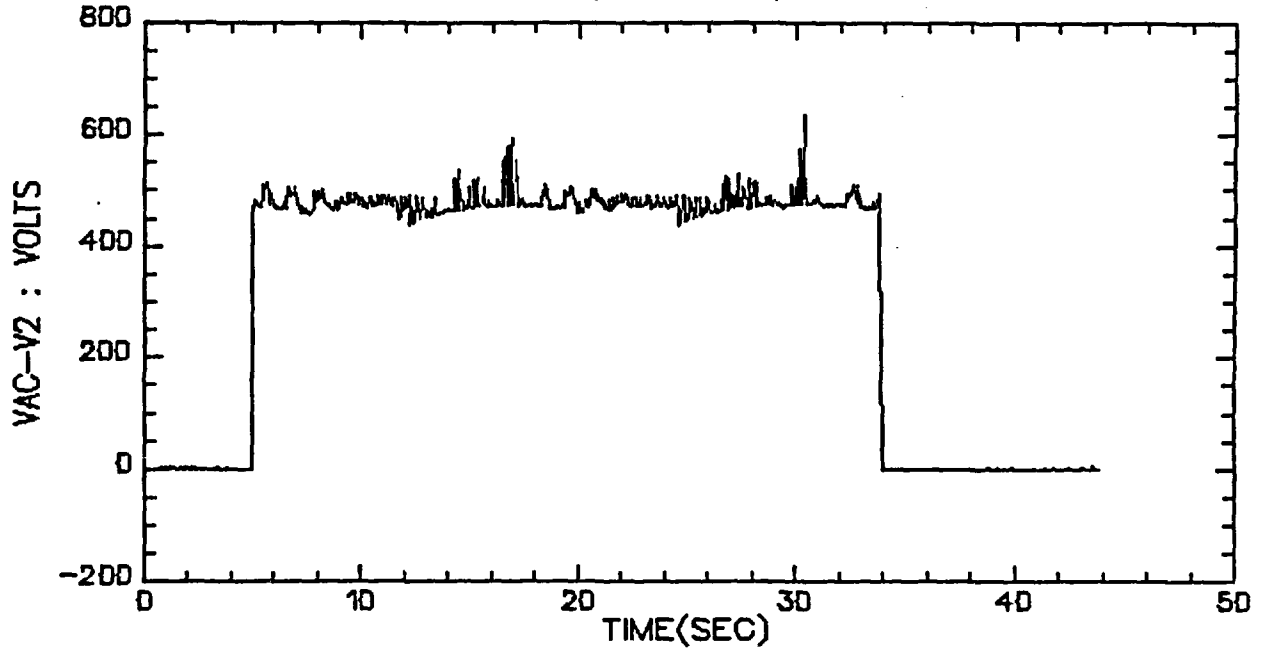

VALVE A, TEST 2, STEP 5

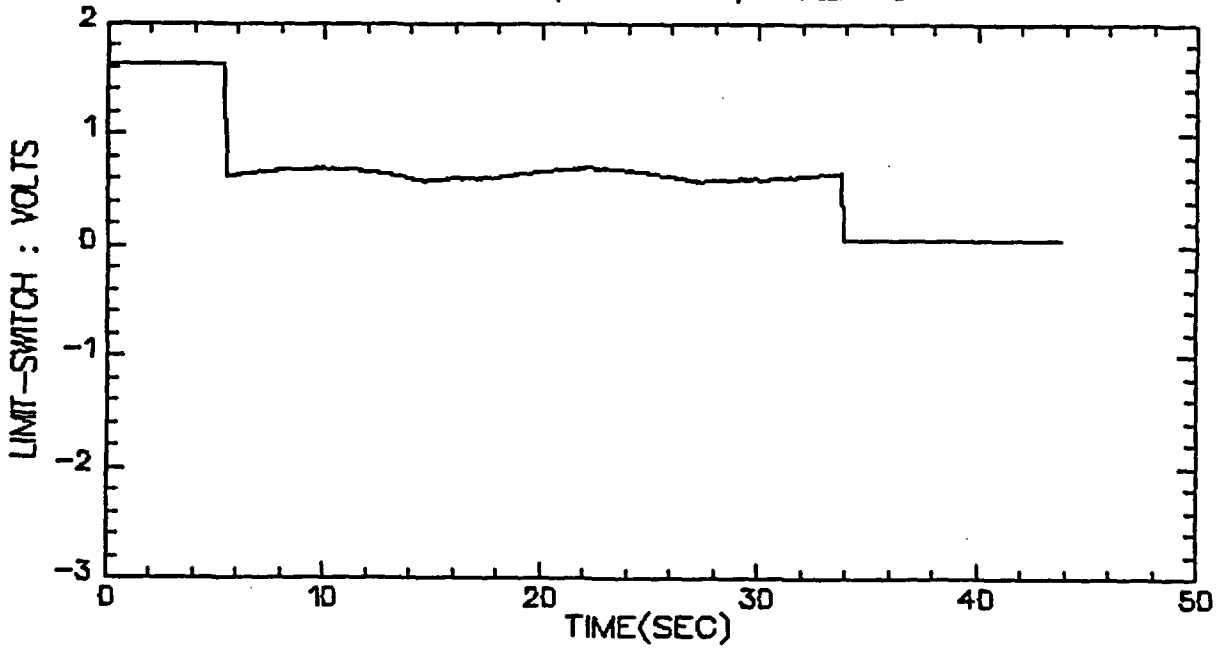

VALVE A, TEST 2, STEP 5

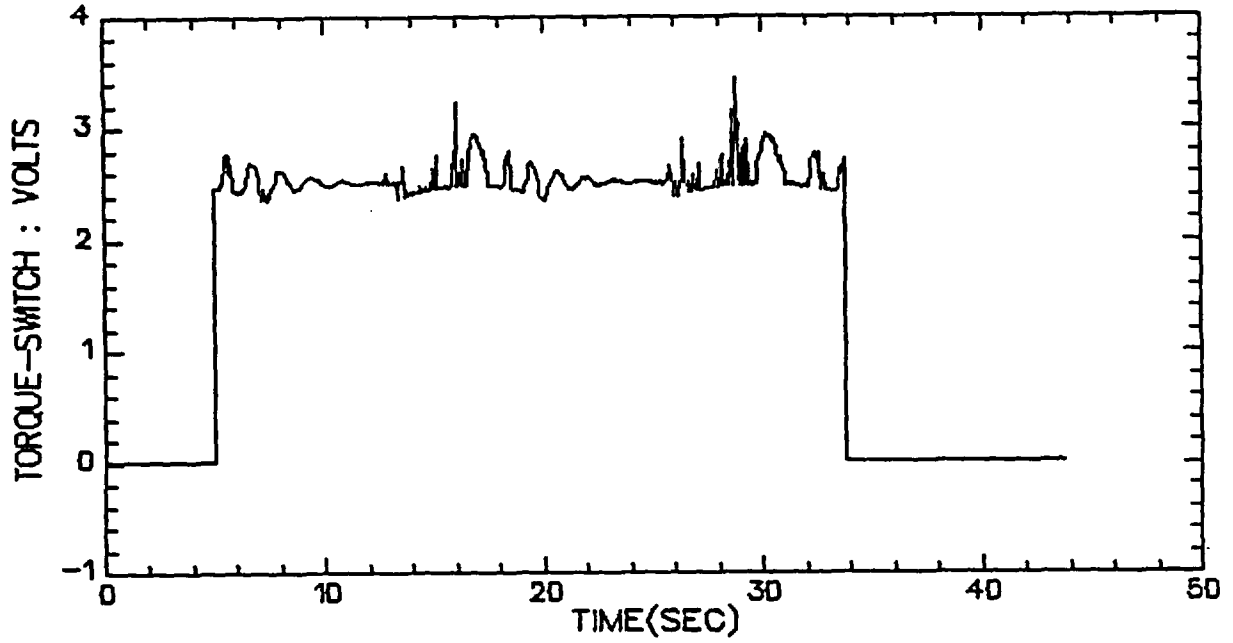

VALVE A, TEST 2, STEP 5

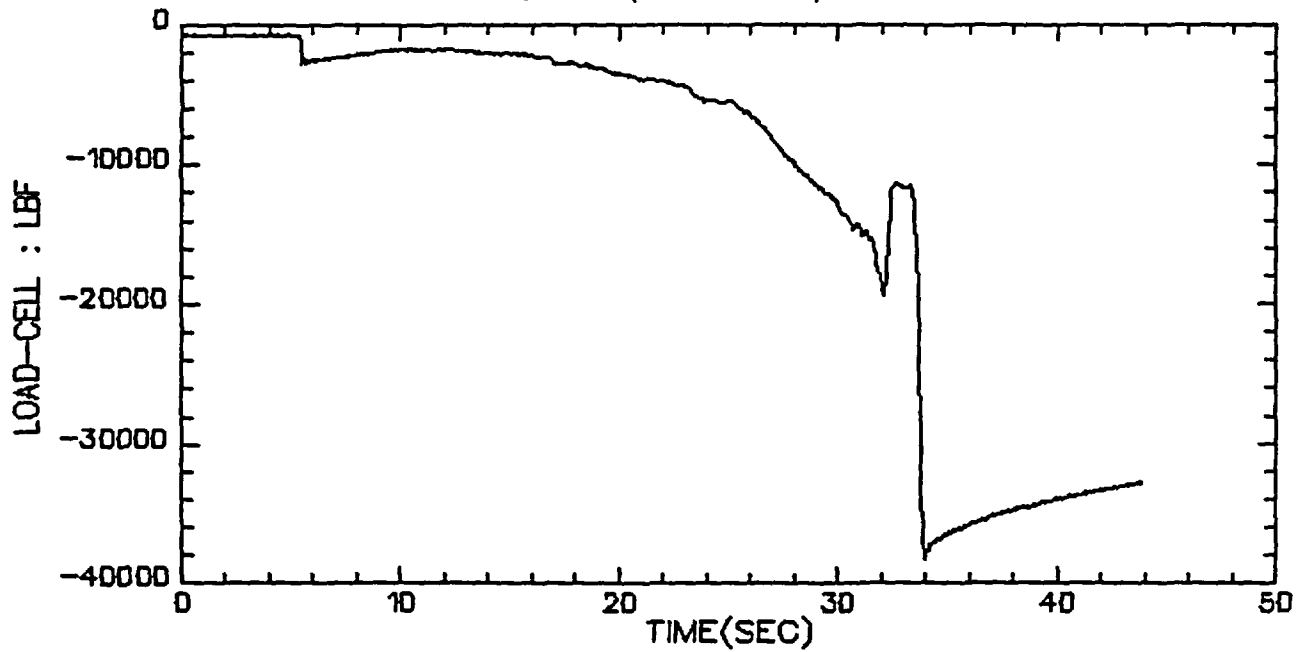

VALVE A, TEST 2, STEP 6&7

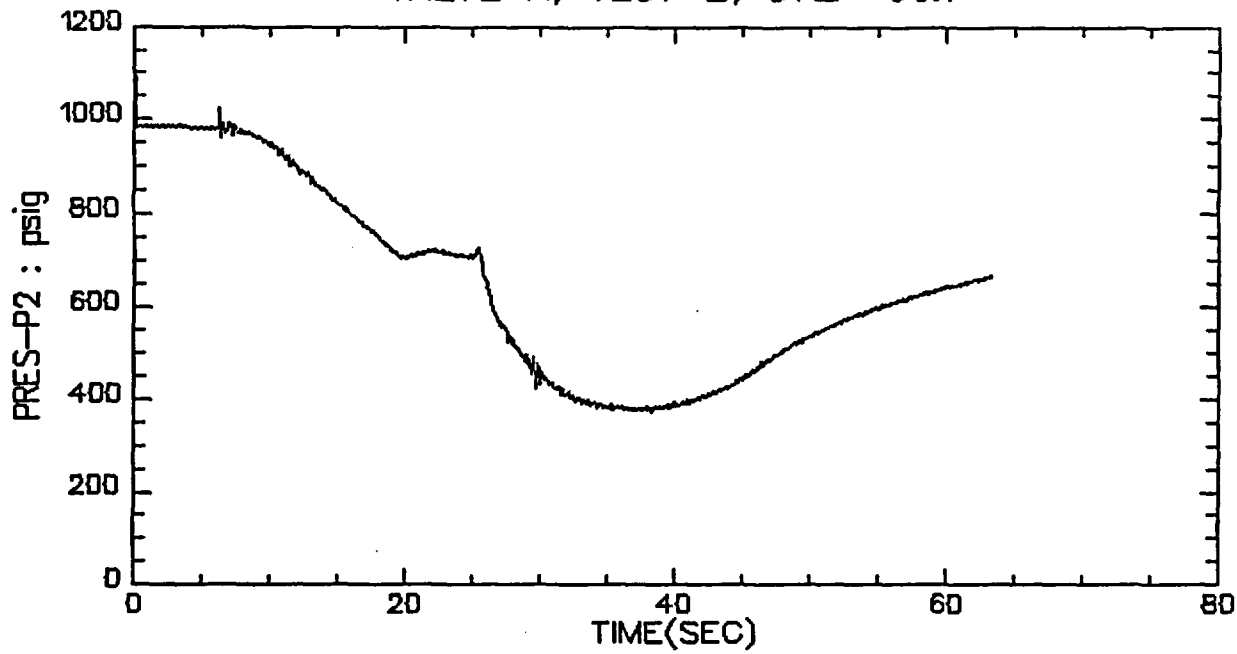

VALVE A, TEST 2, STEP 6&7

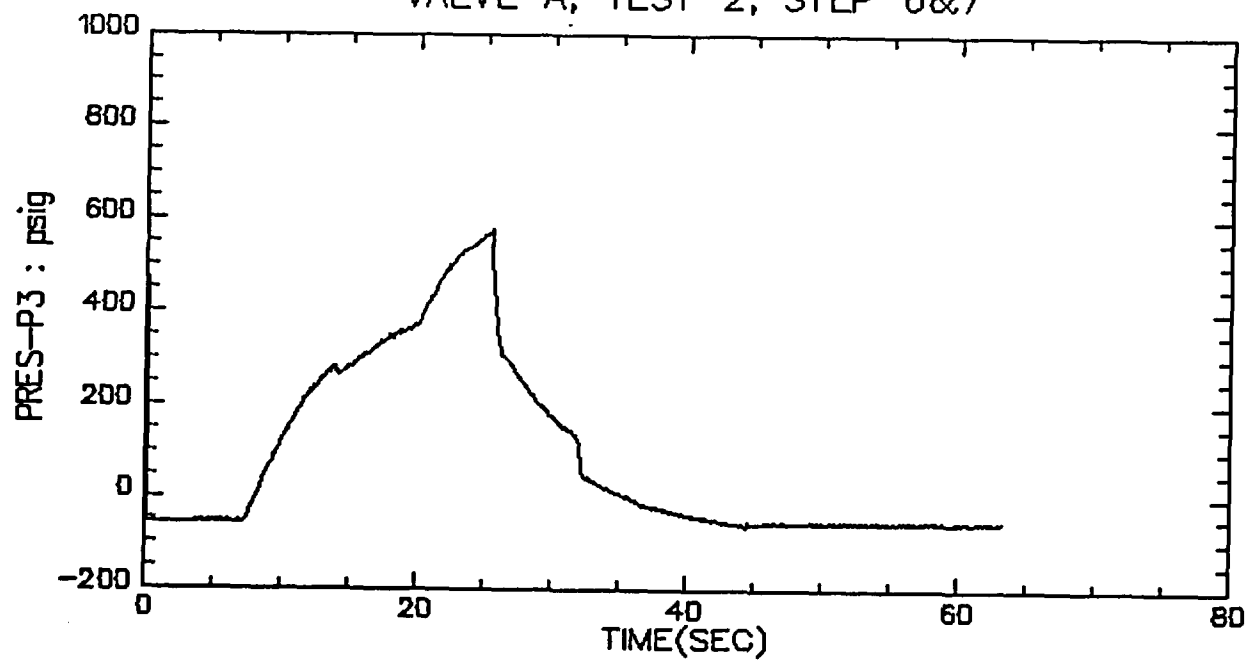

VALVE A, TEST 2, STEP 6&7

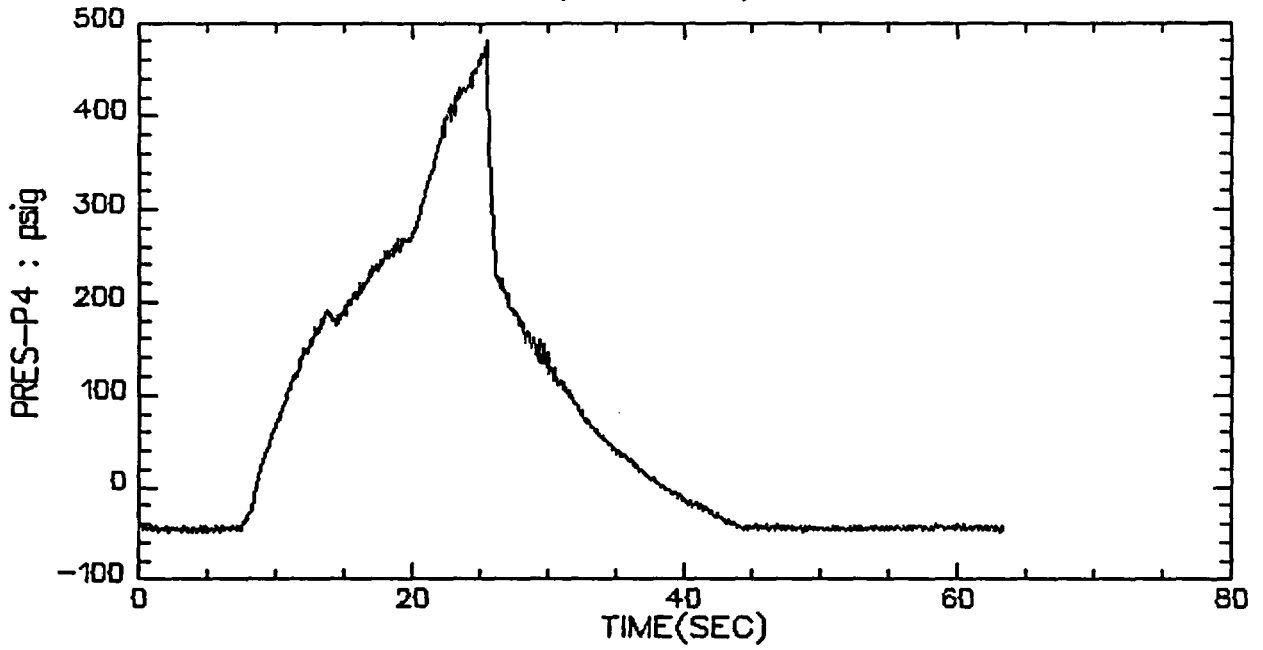

VALVE A, TEST 2, STEP 6&7

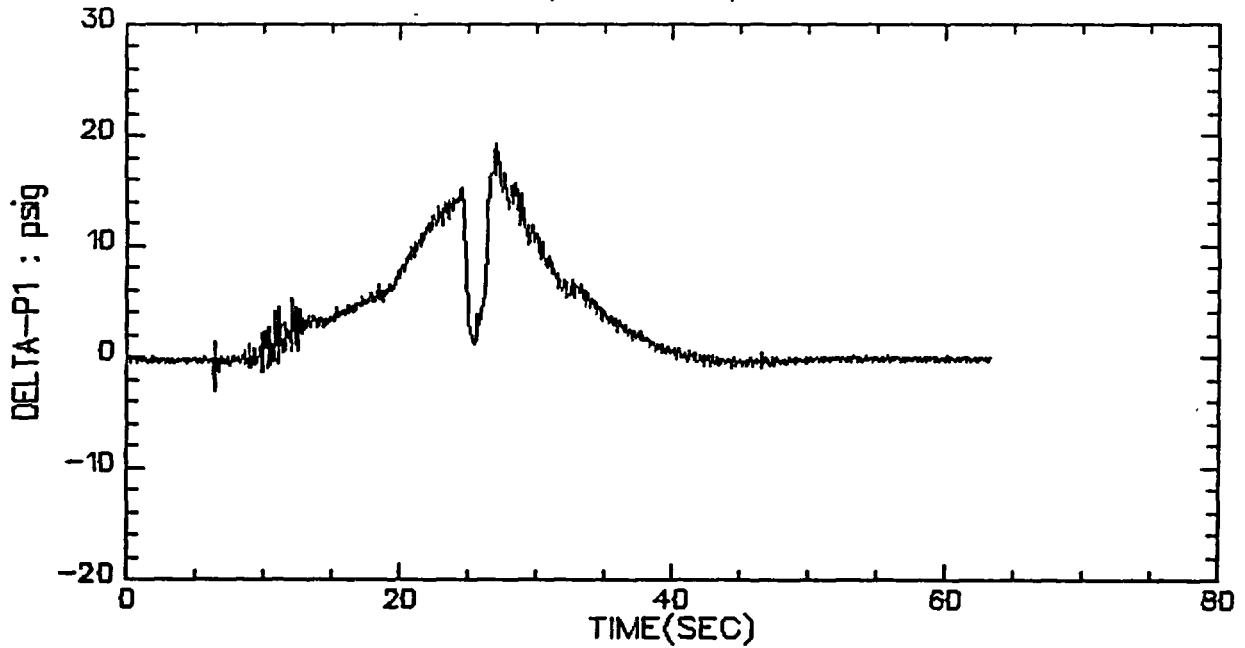

VALVE A, TEST 2, STEP 6&7

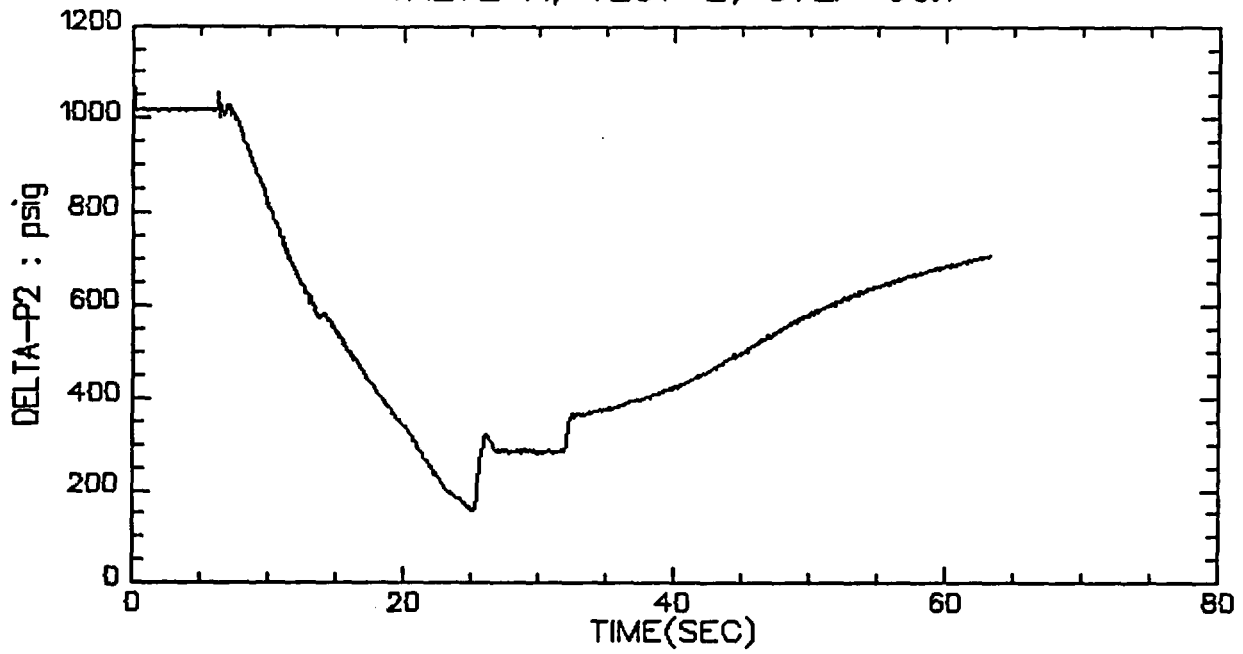

VALVE A, TEST 2, STEP 6&7

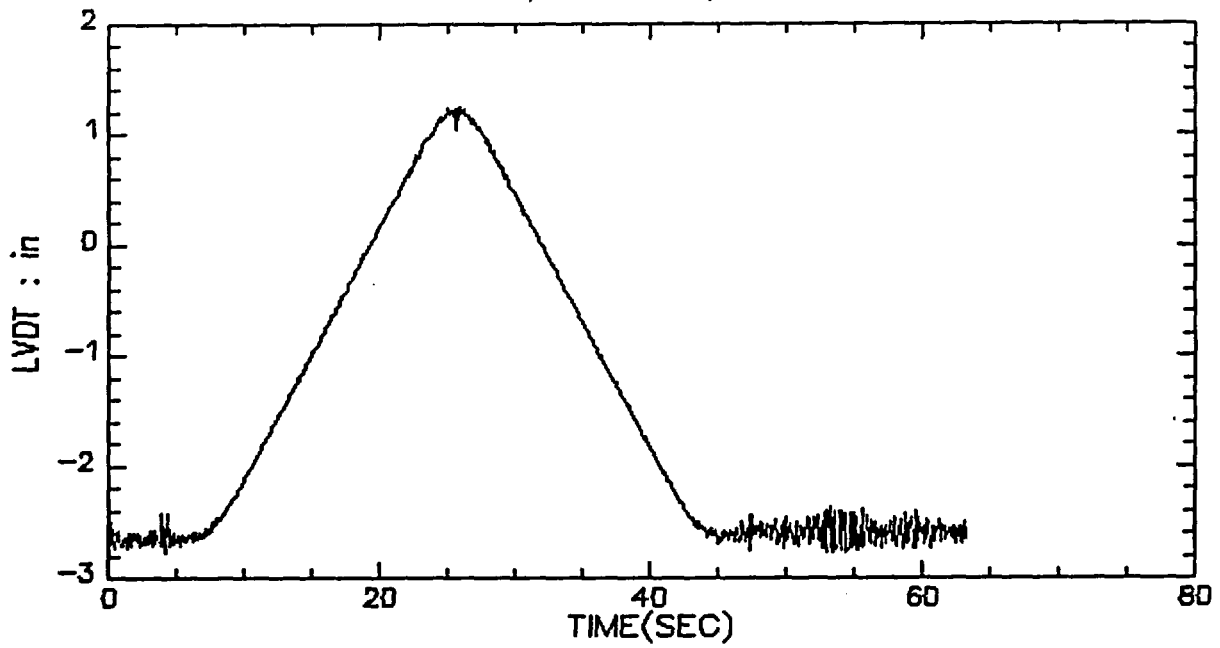

VALVE A, TEST 2, STEP 6&7

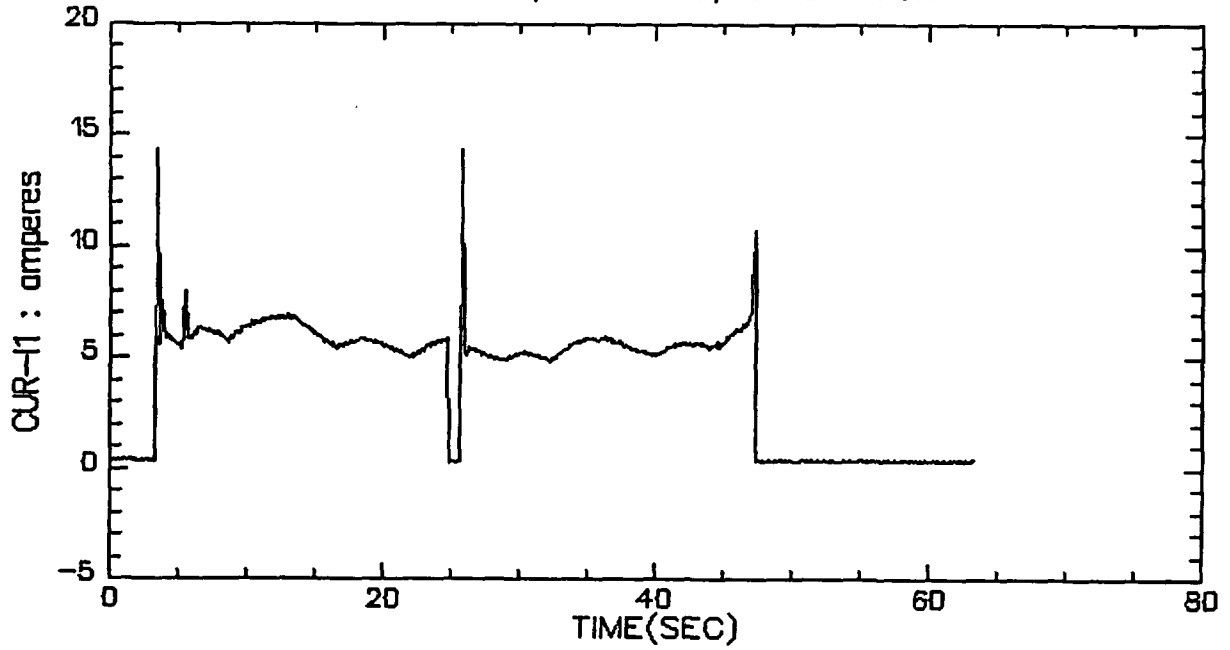

VALVE A, TEST 2, STEP 6&7

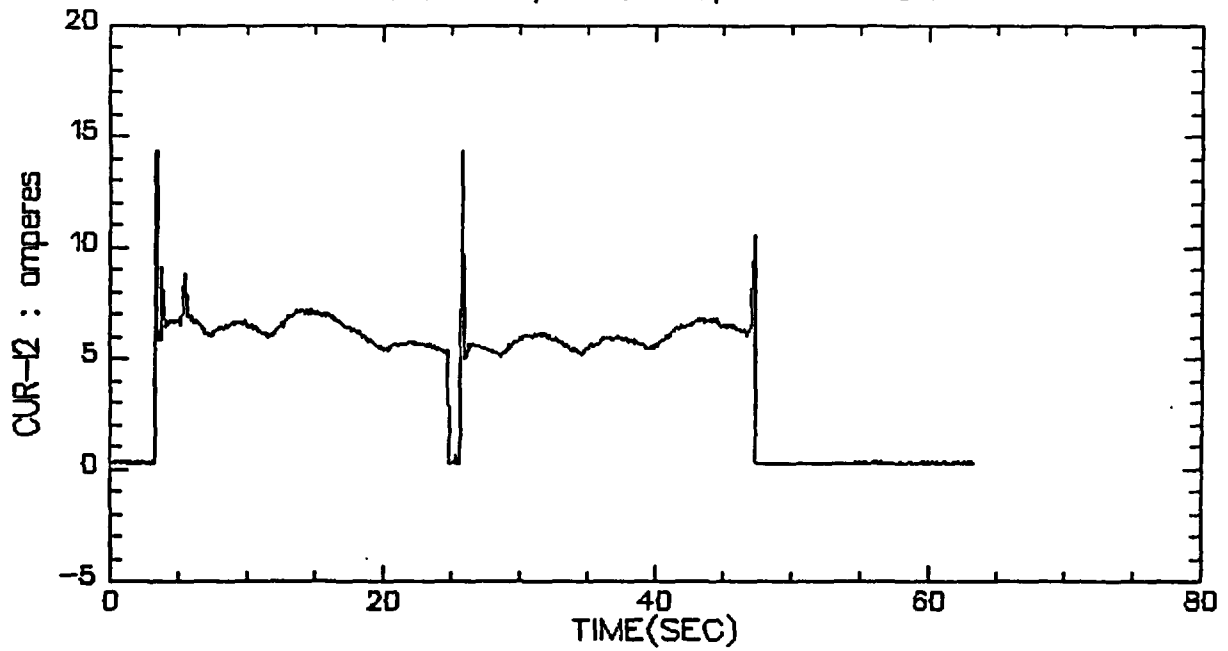

VALVE A, TEST 2, STEP 6&7

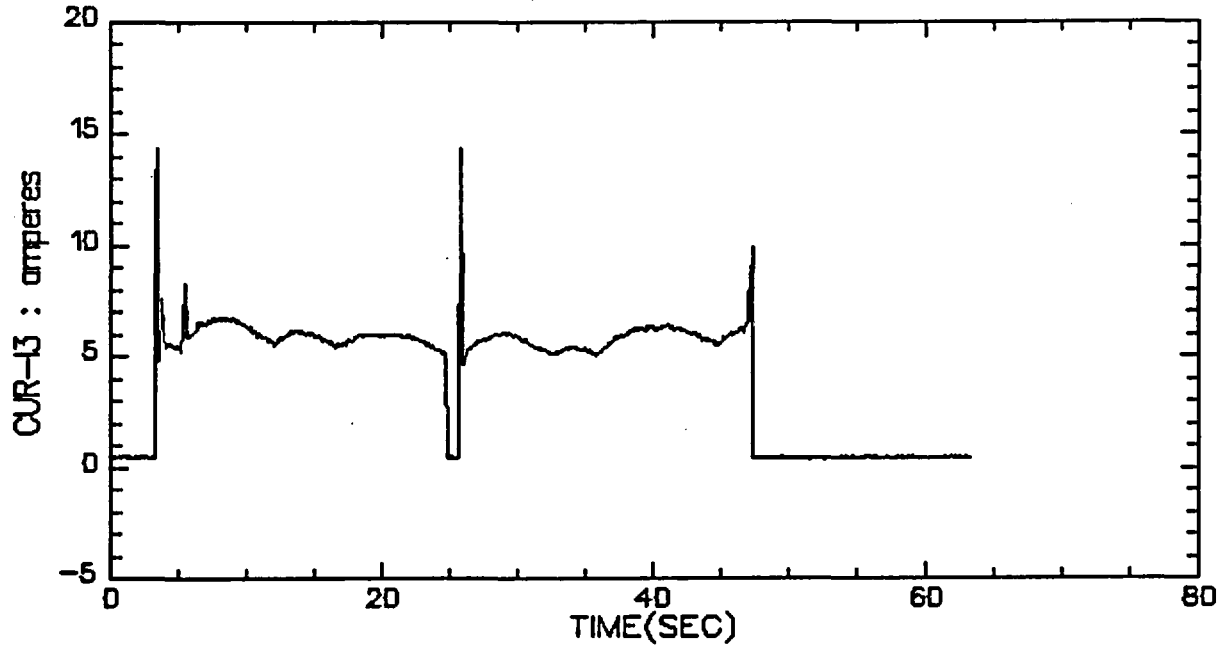

VALVE A, TEST 2, STEP 6&7

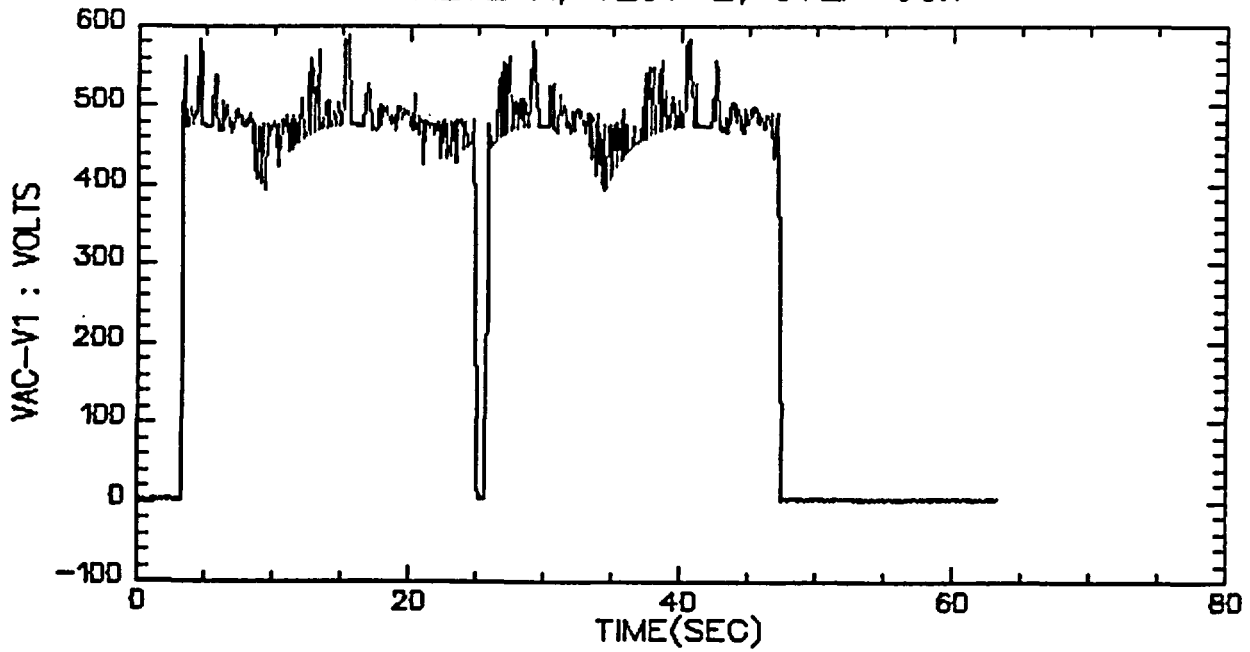

VALVE A, TEST 2, STEP 6&7

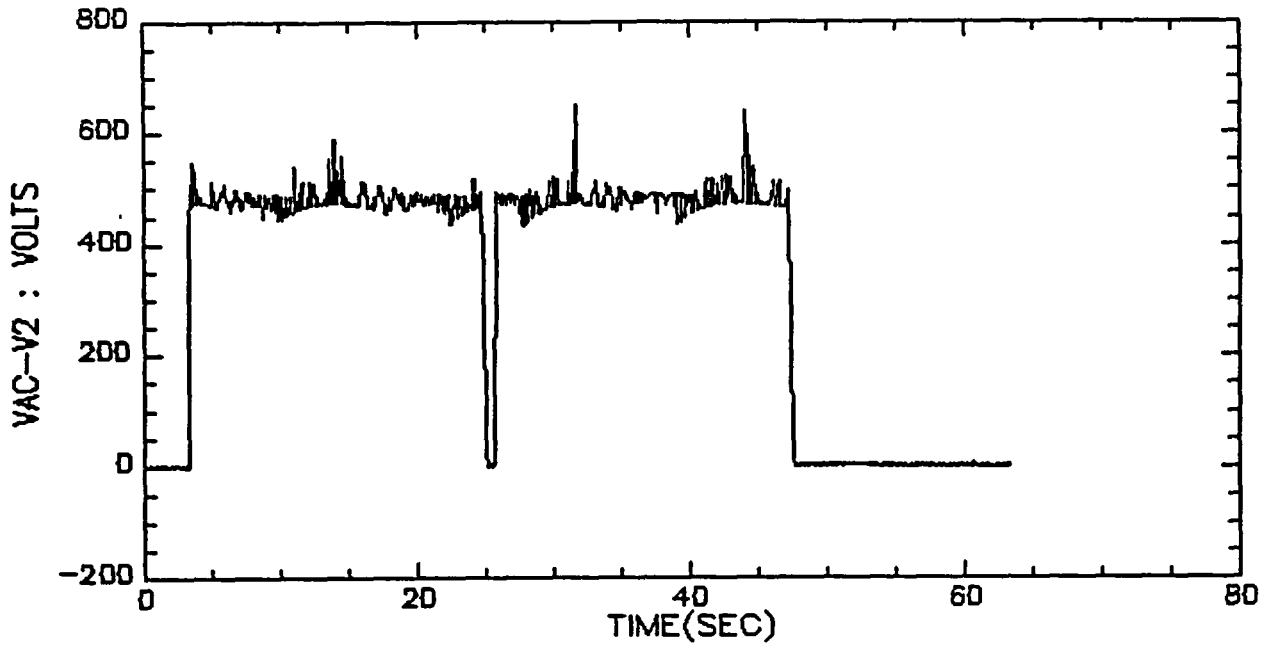

VALVE A, TEST 2, STEP 6&7

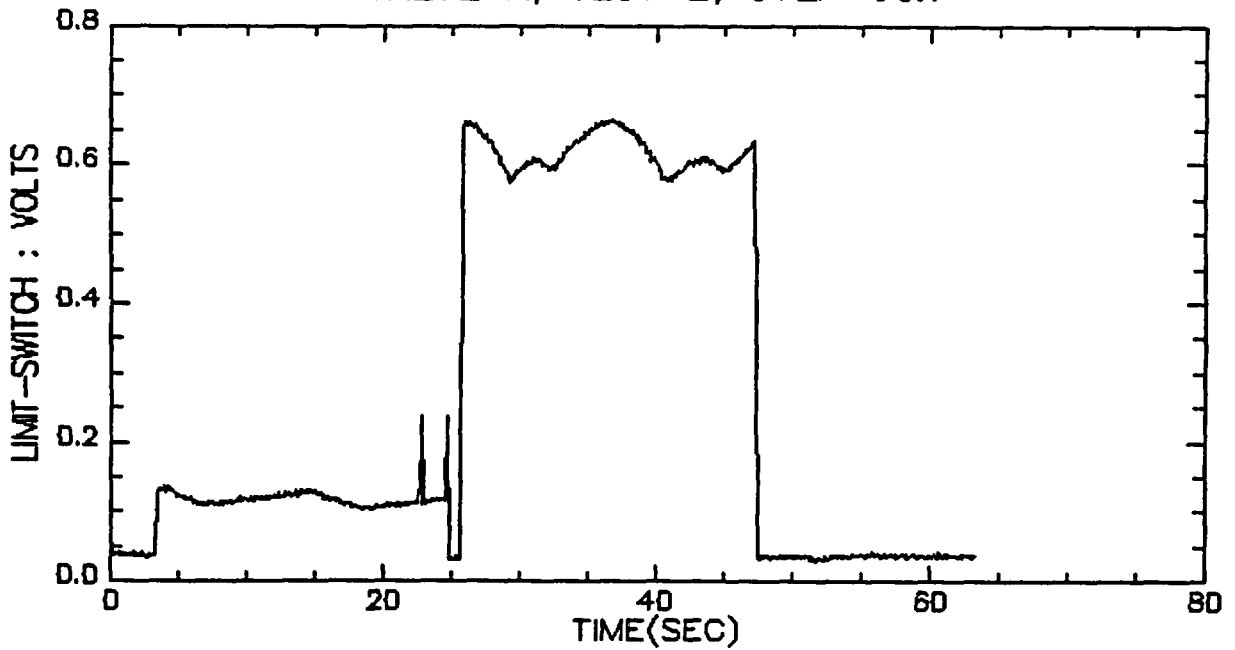

VALVE A, TEST 2, STEP 6&7

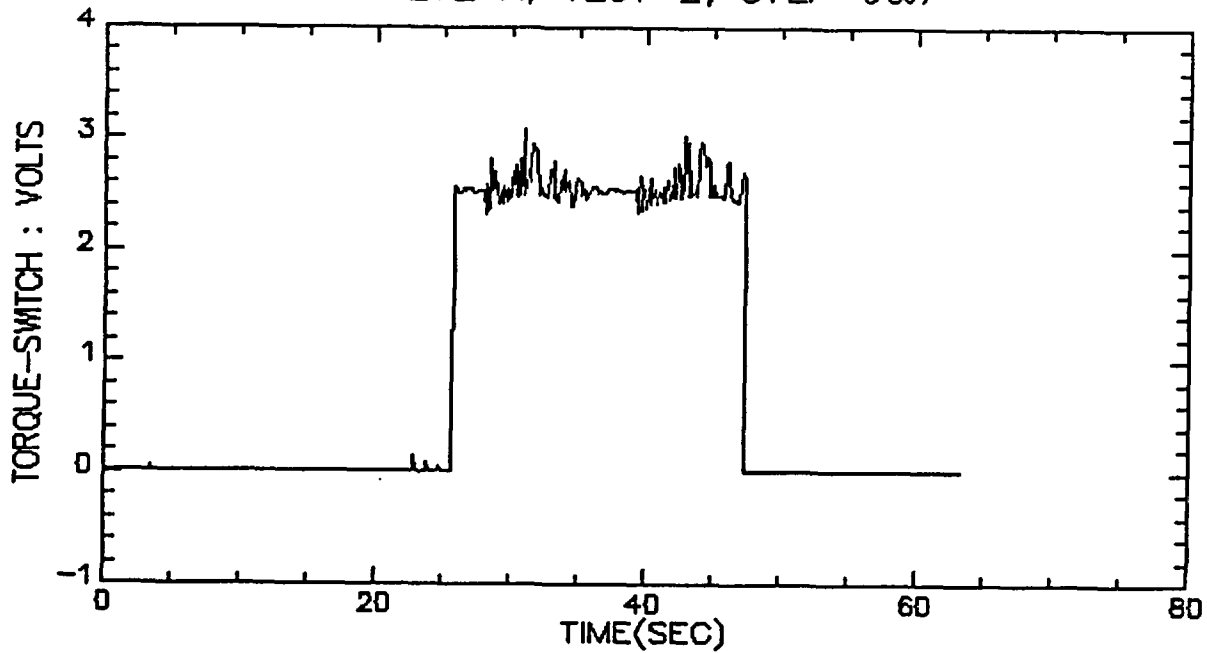

VALVE A, TEST 2, STEP 6&7

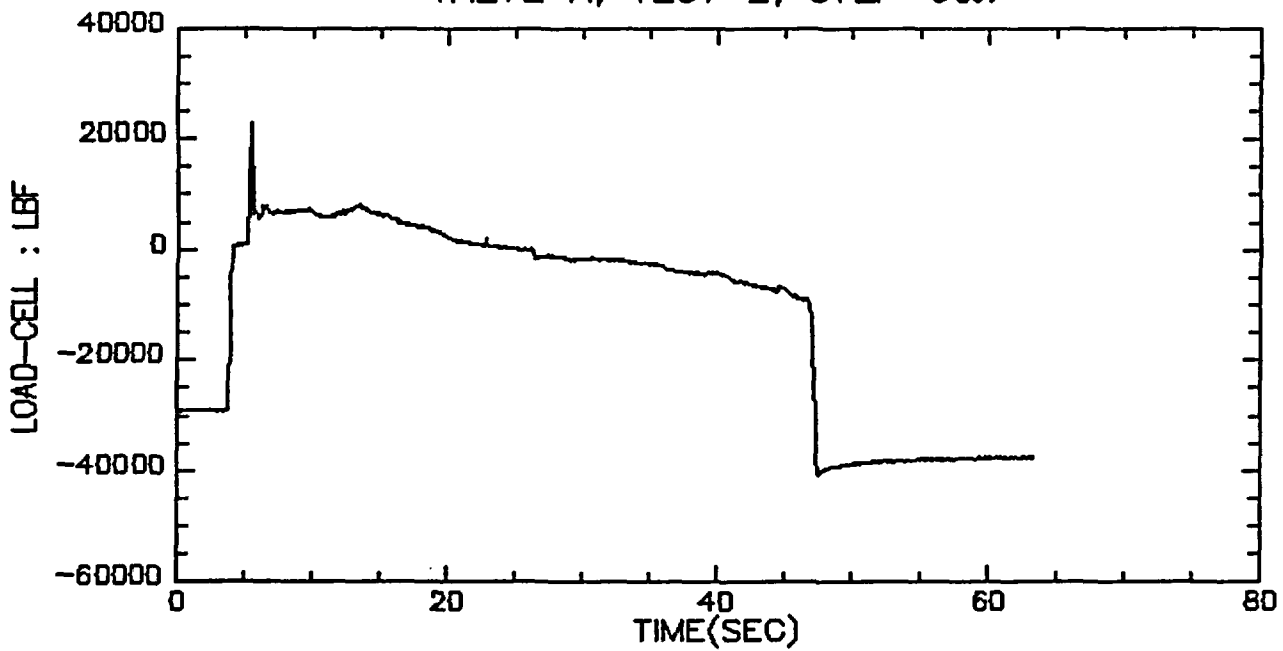

VALVE A, TEST 2, STEP 8&9

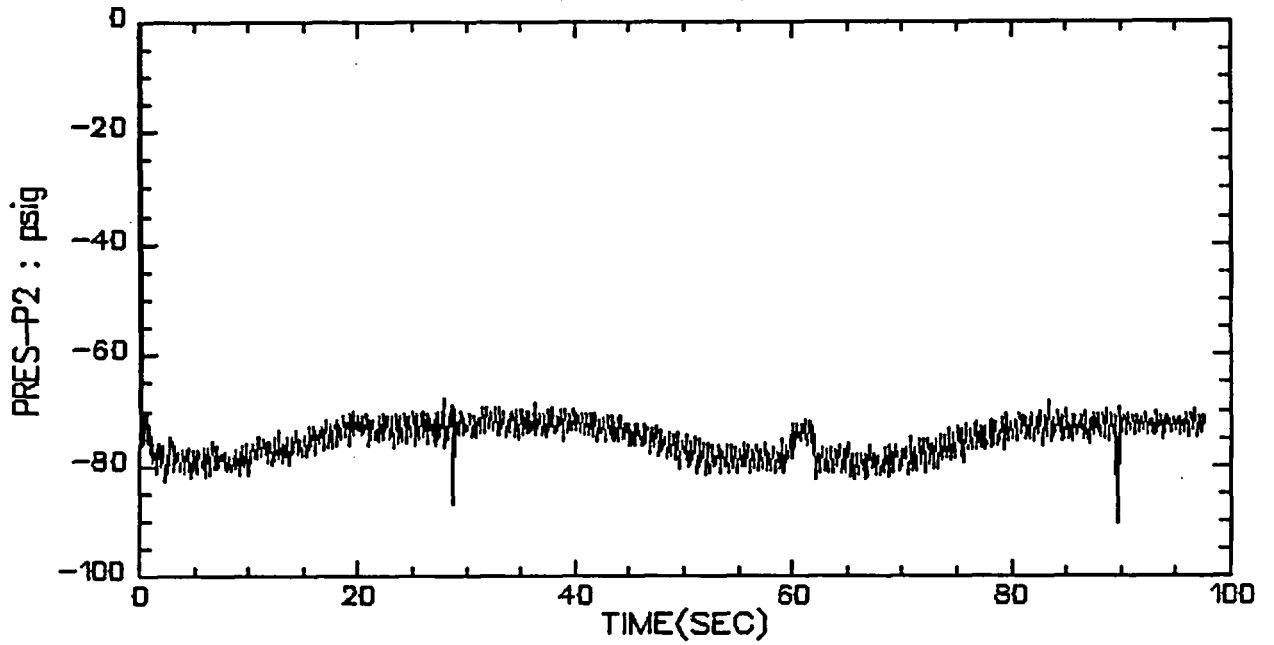

VALVE A, TEST 2, STEP 8&9

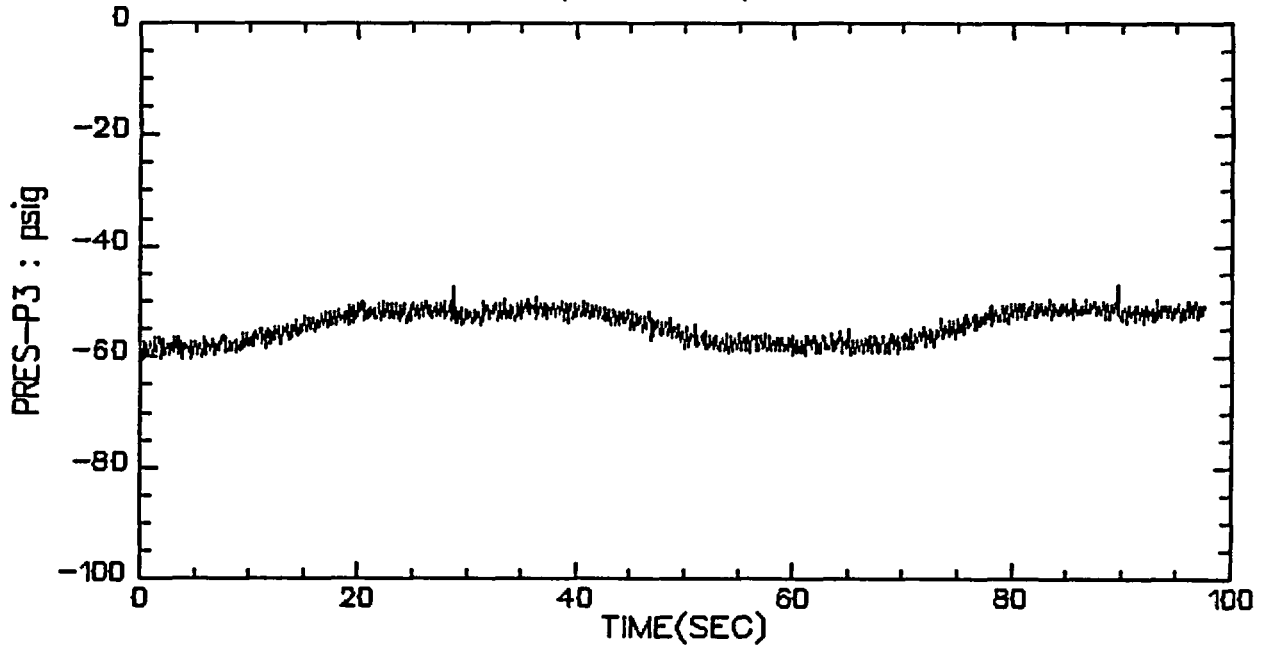

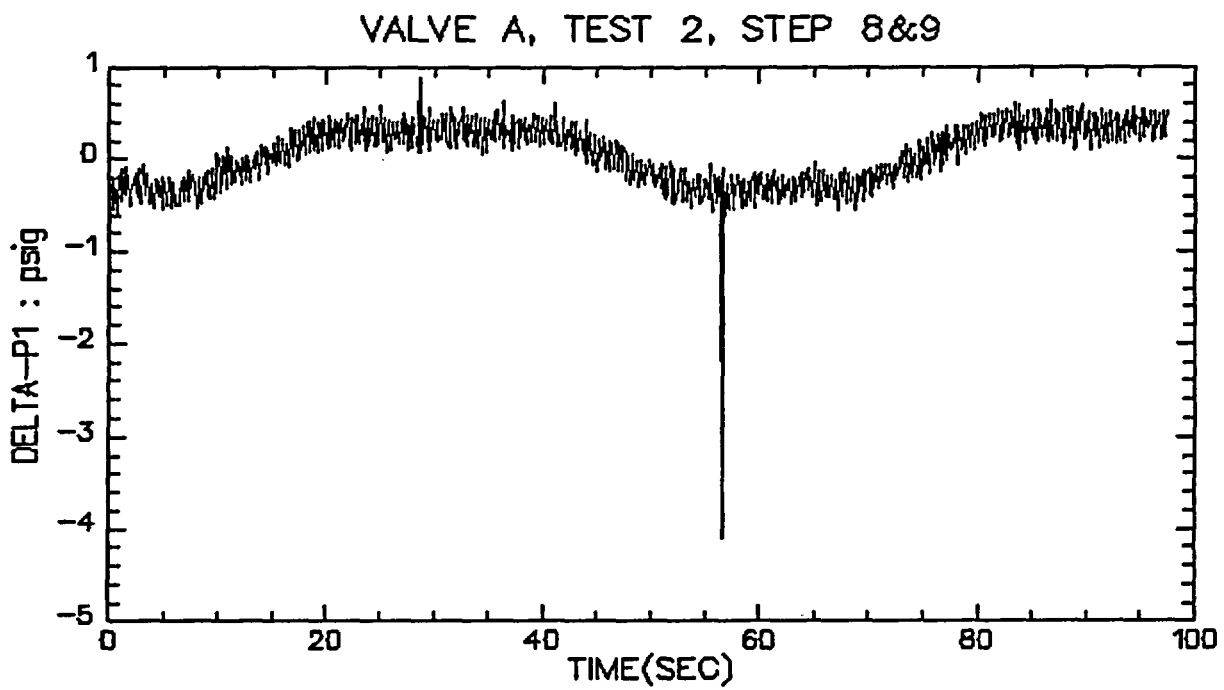
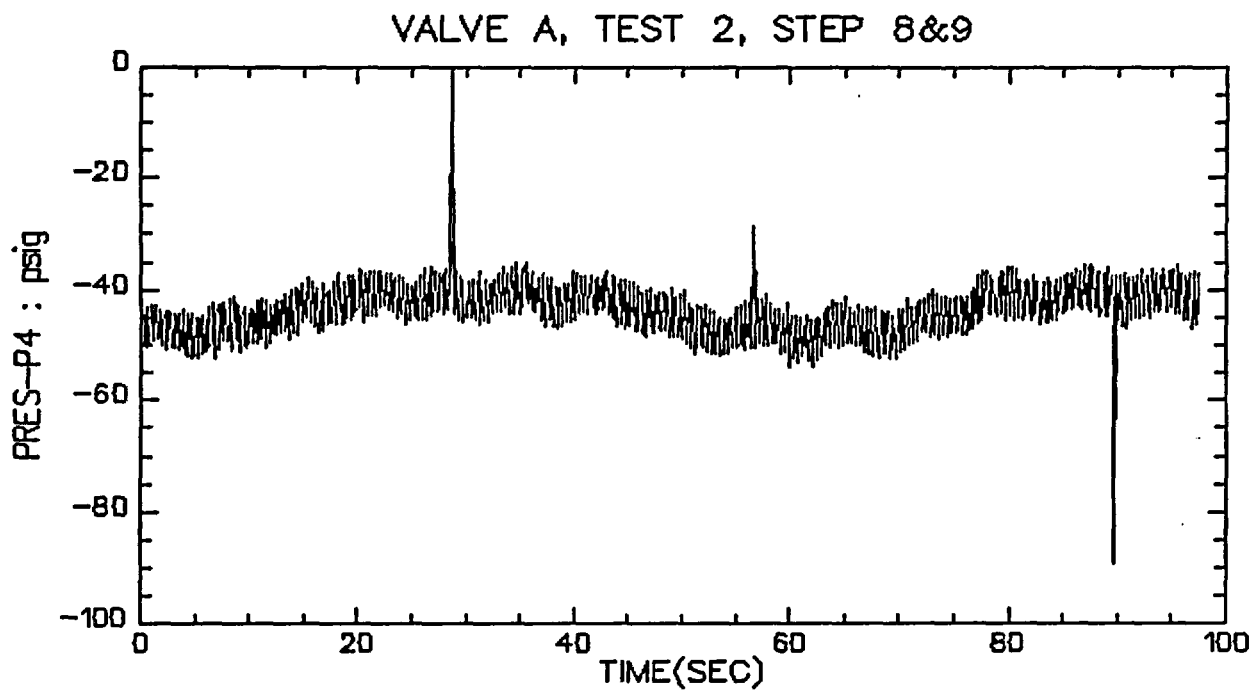

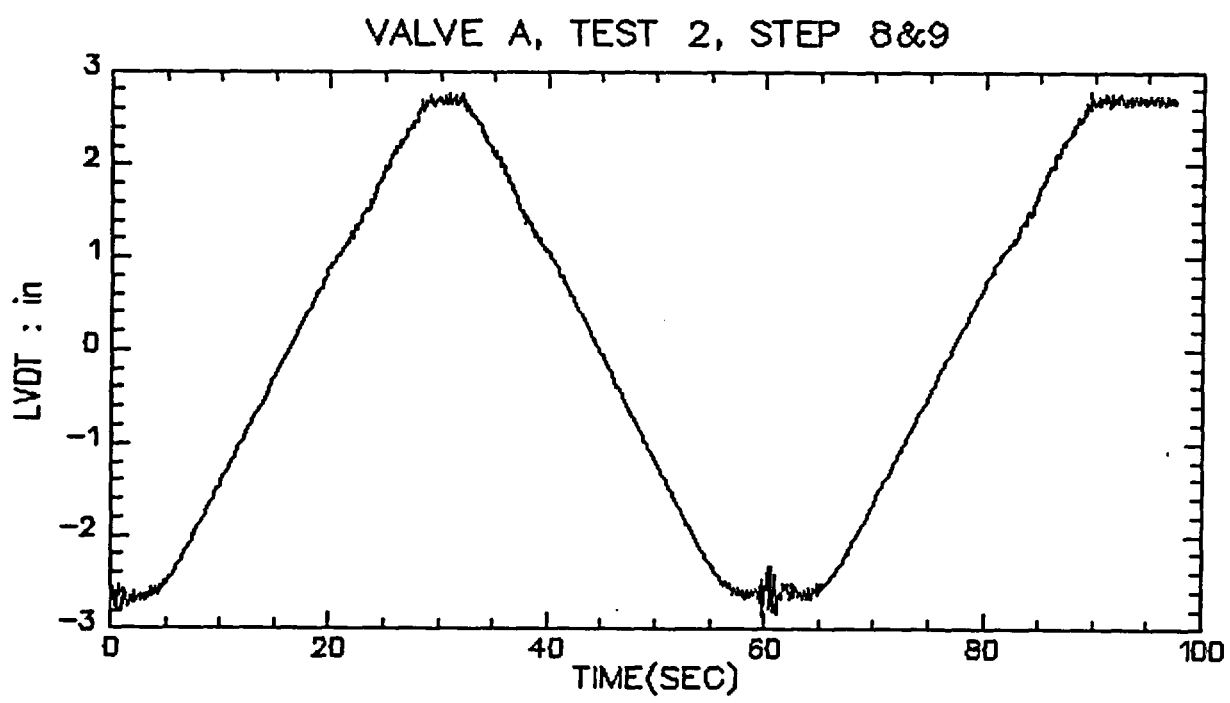
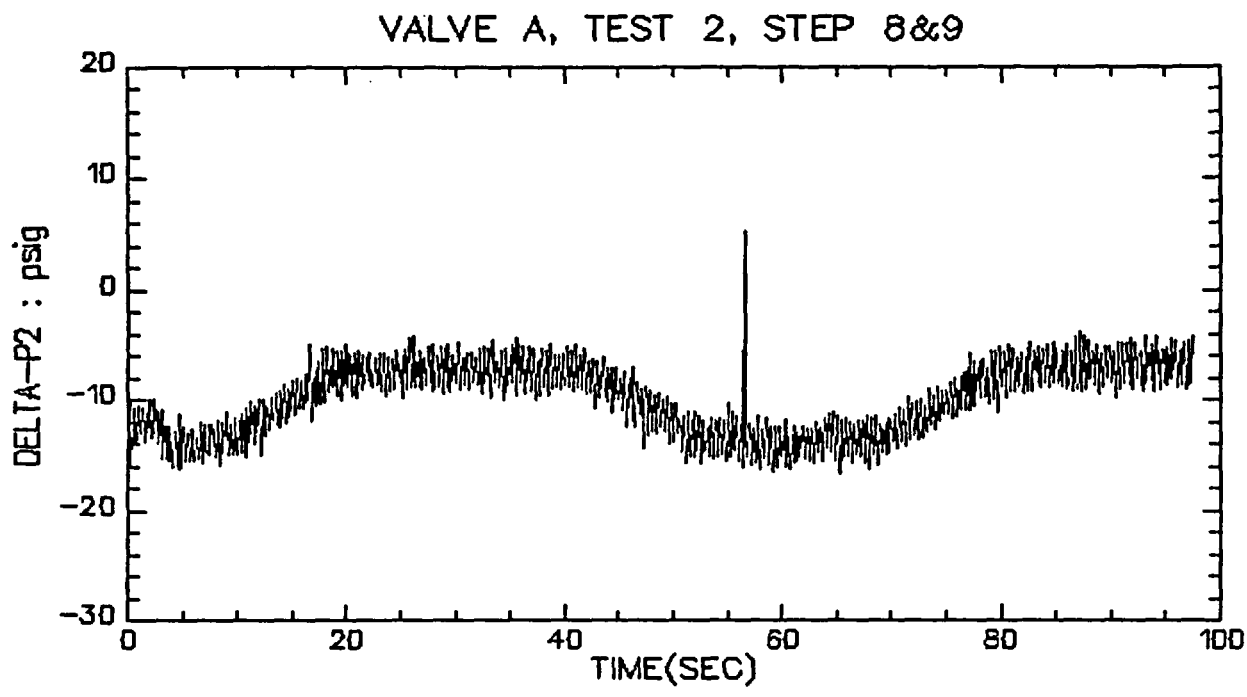

VALVE A, TEST 2, STEP 8&9

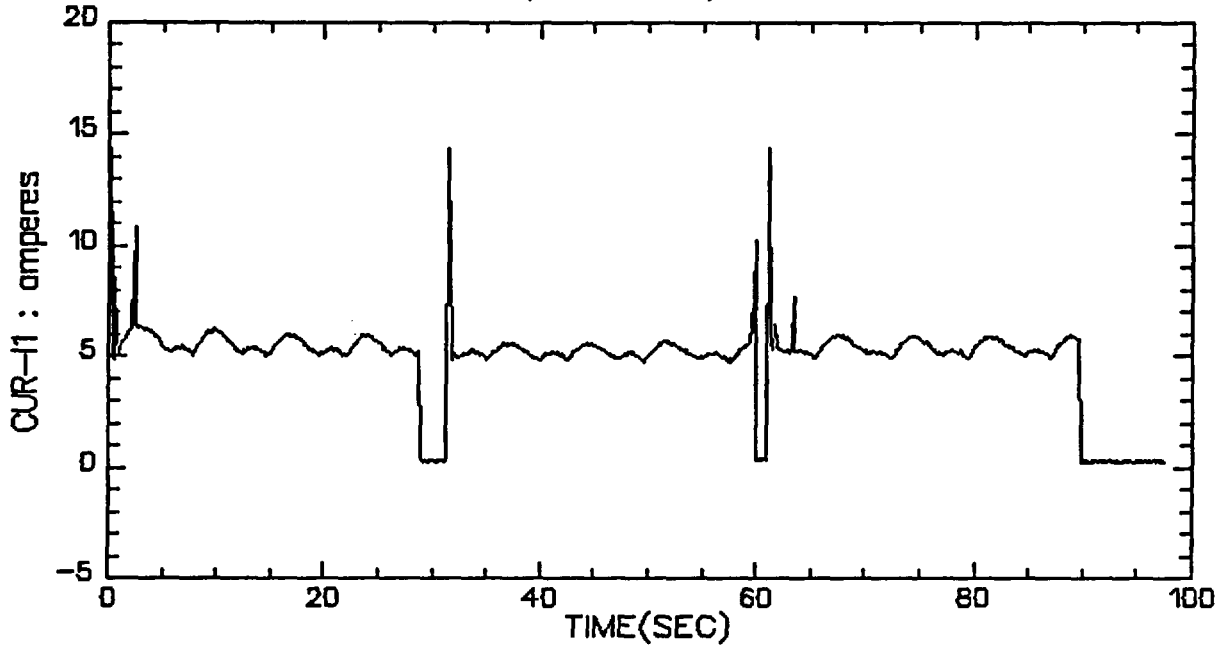

VALVE A, TEST 2, STEP 8&9

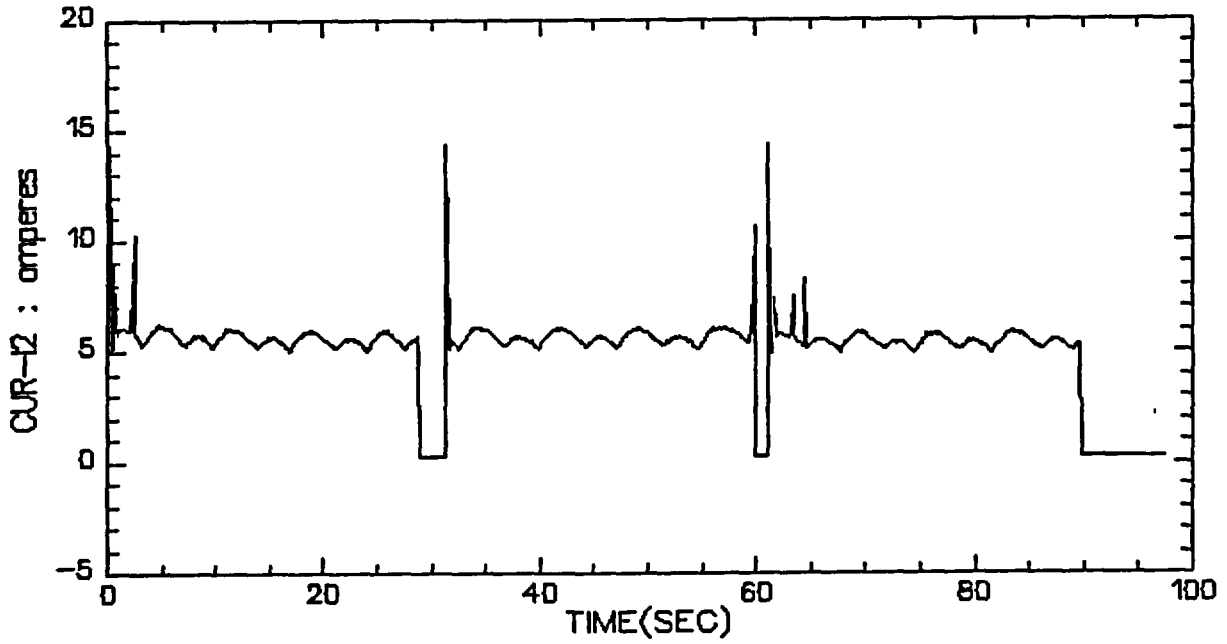

VALVE A, TEST 2, STEP 8&9

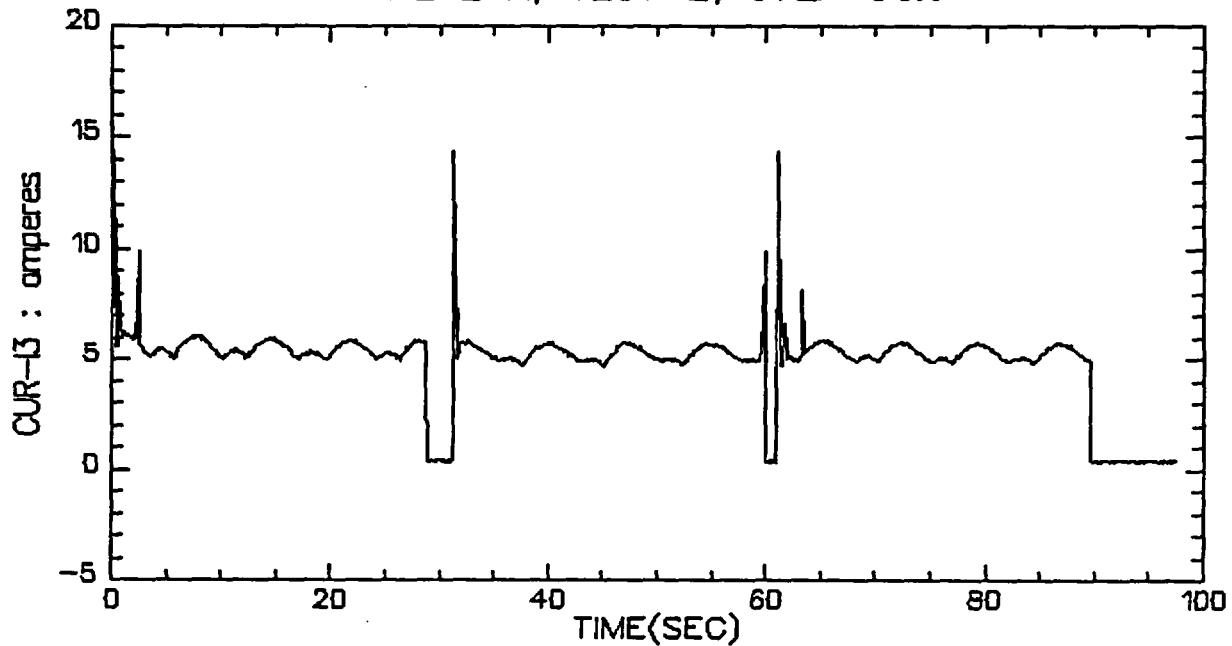

VALVE A, TEST 2, STEP 8&9

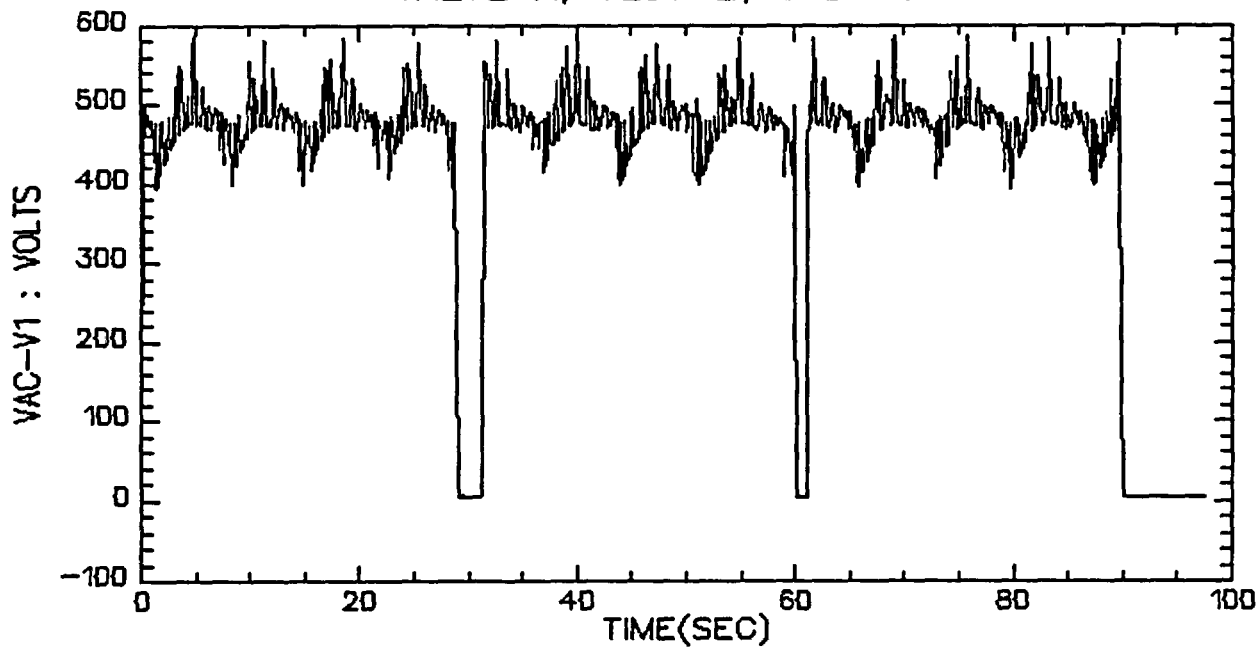

VALVE A, TEST 2, STEP 8&9

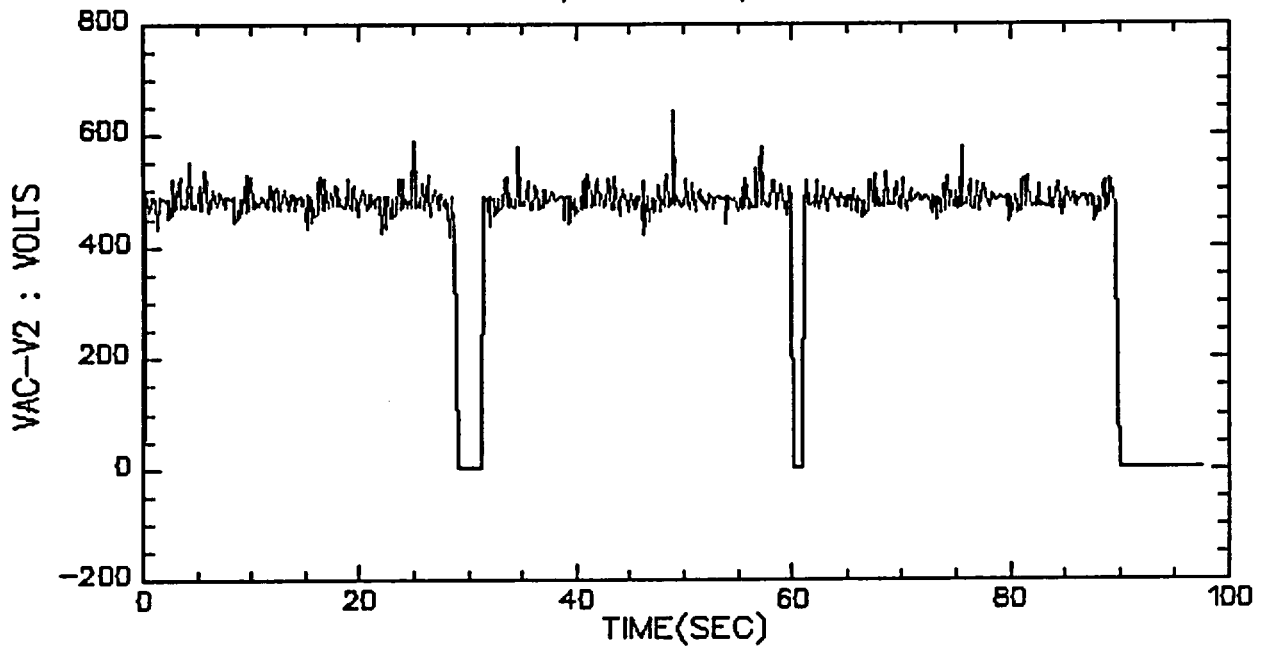

VALVE A, TEST 2, STEP 8&9

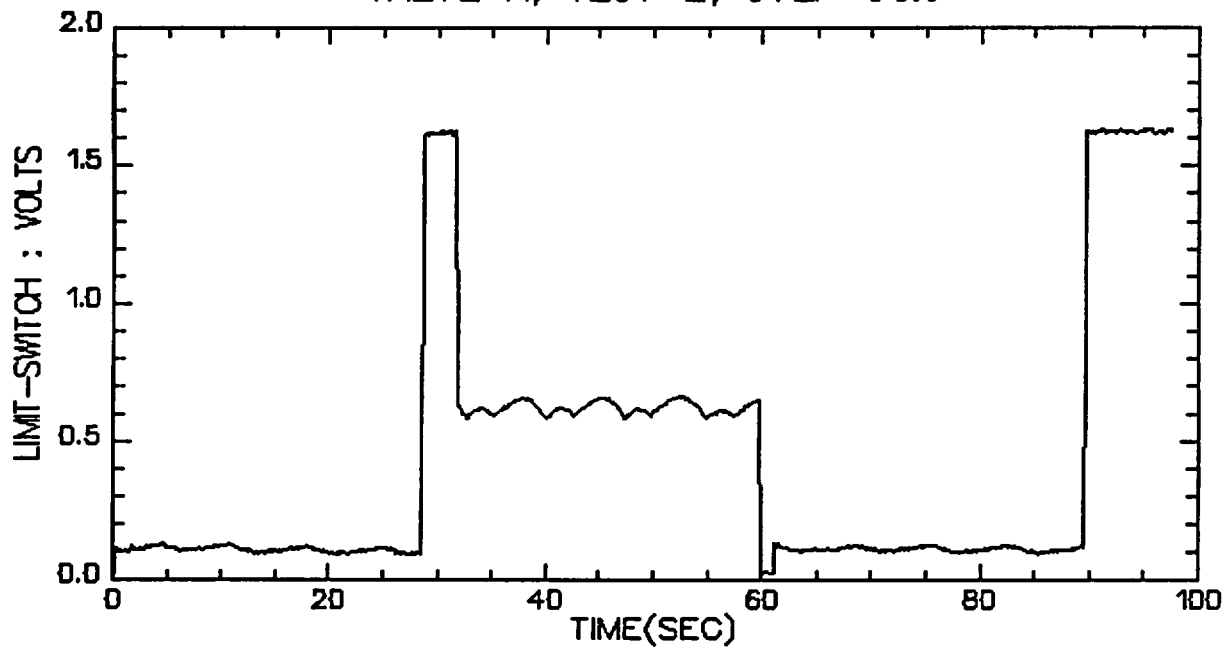

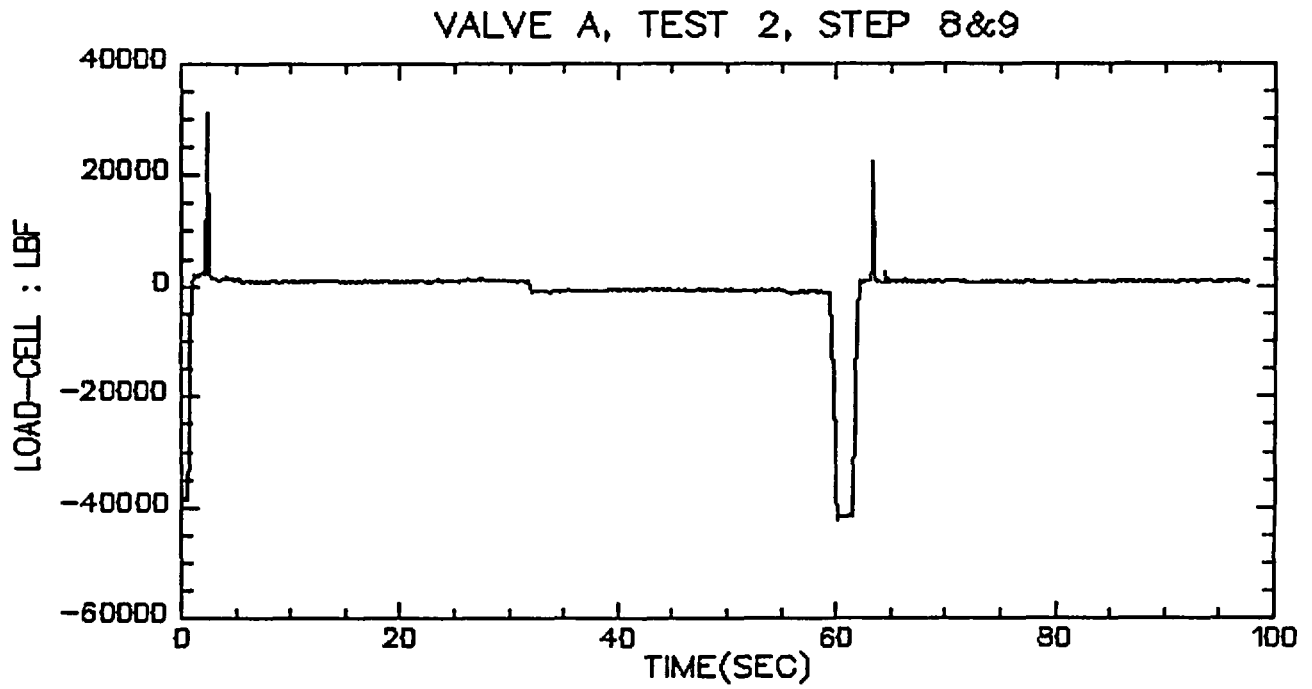
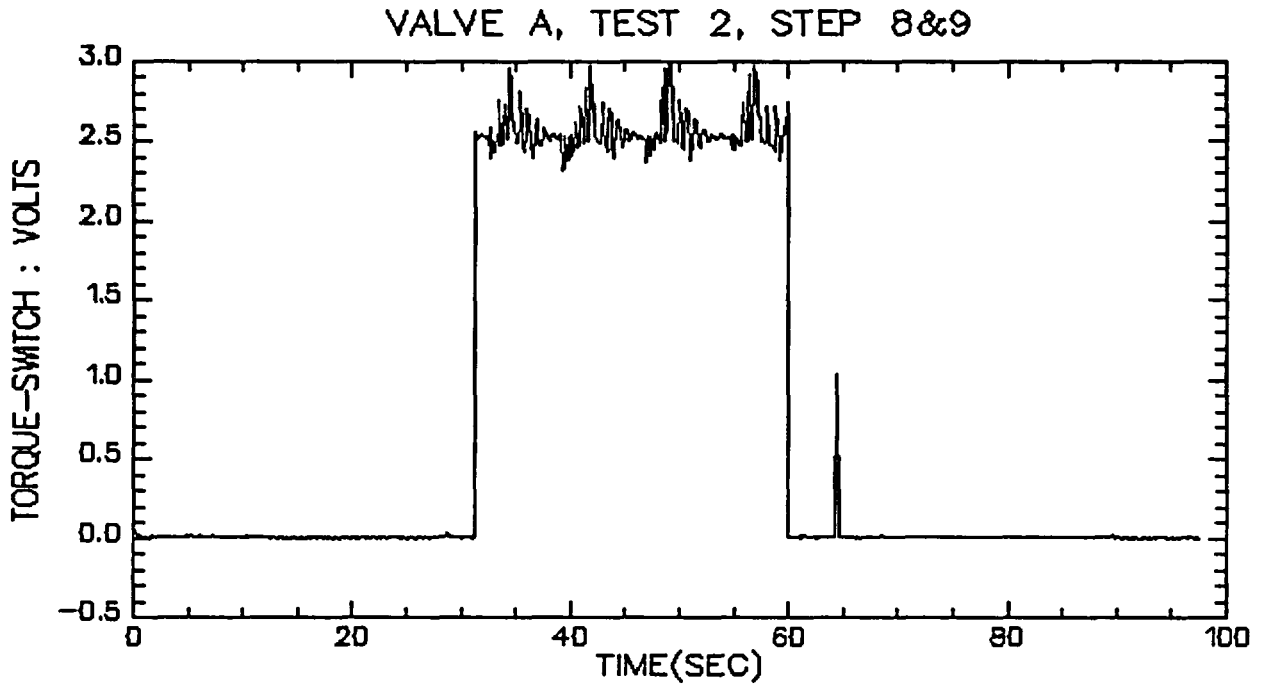

VALVE A, TEST 3, STEP 1

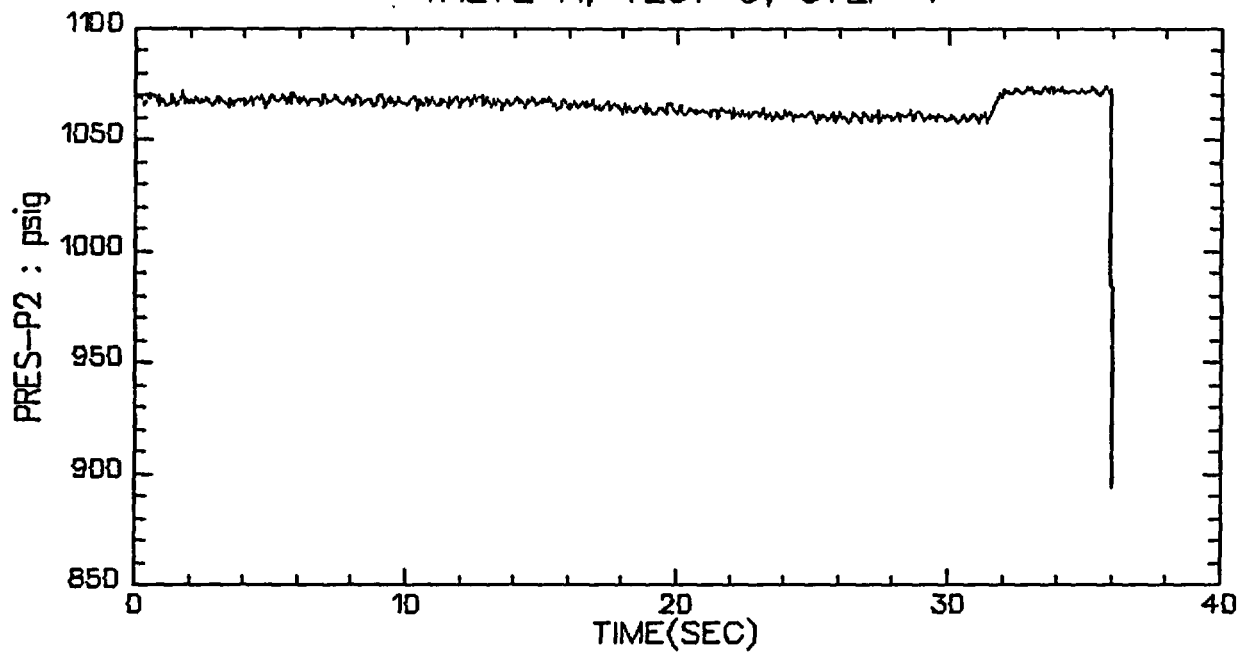

VALVE A, TEST 3, STEP 1

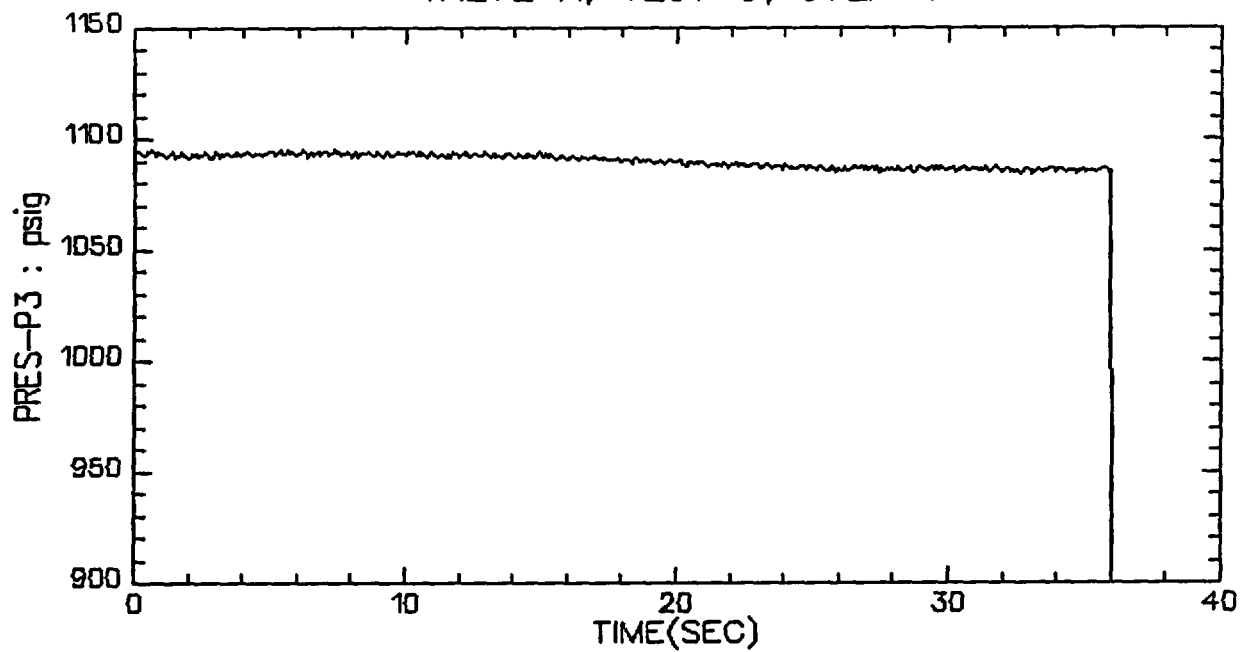

VALVE A, TEST 3, STEP 1

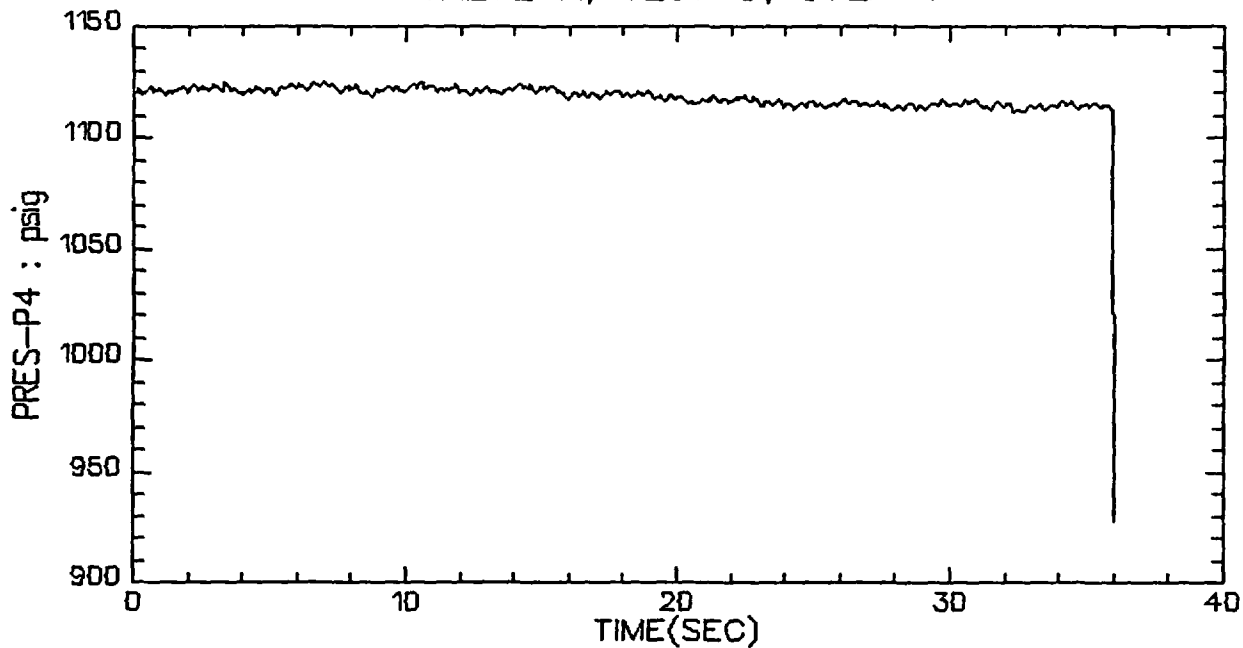

VALVE A, TEST 3, STEP 1

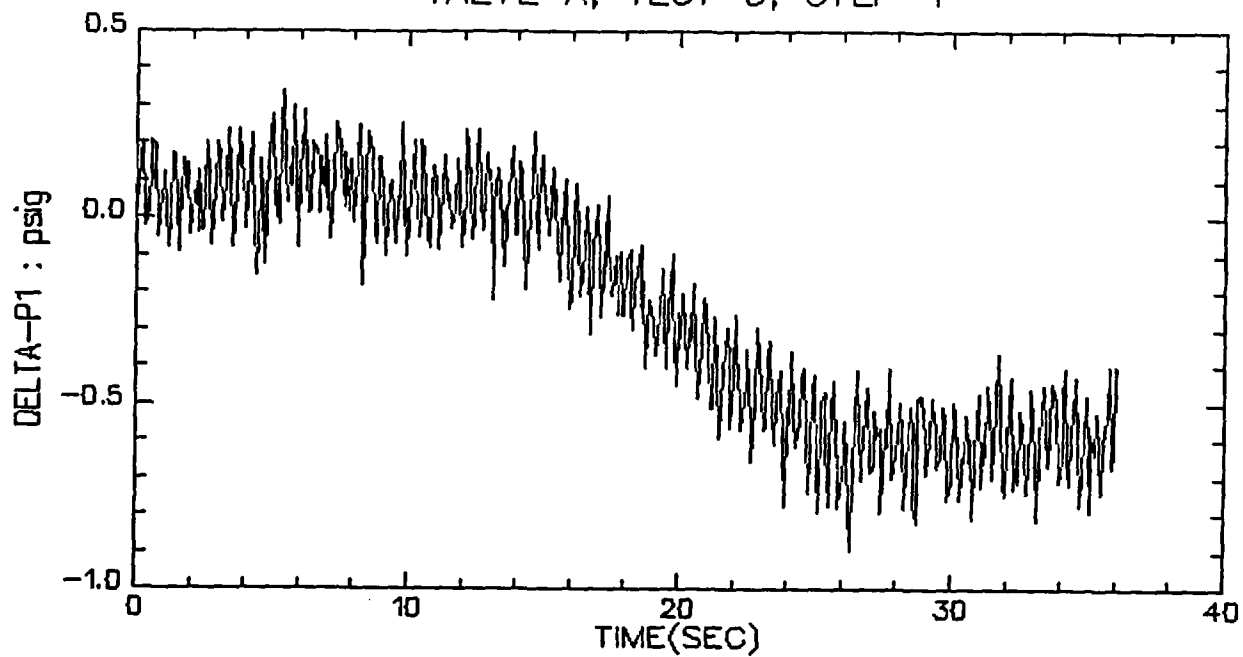

VALVE A, TEST 3, STEP 1

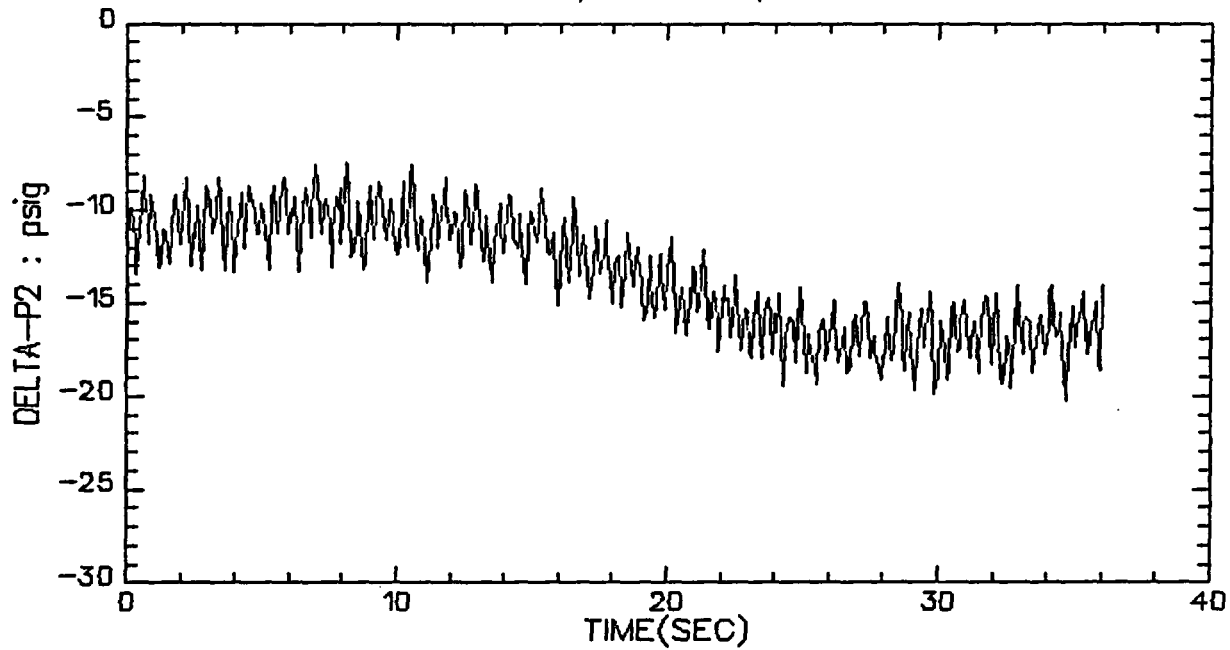

VALVE A, TEST 3, STEP 1

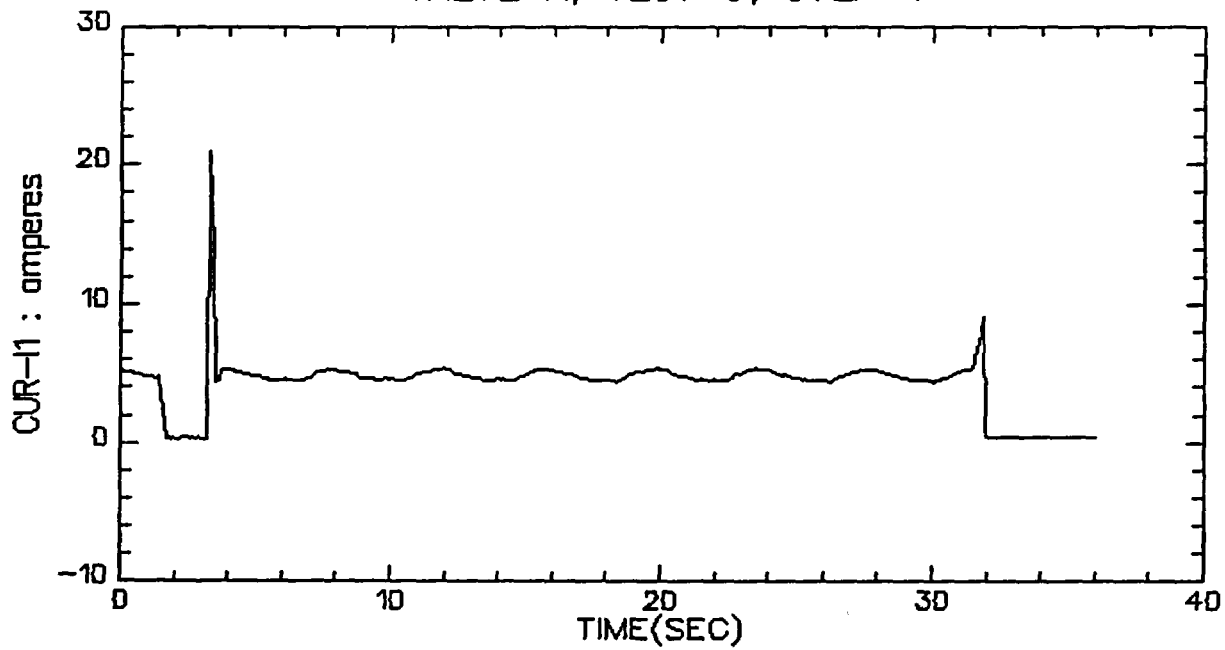

VALVE A, TEST 3, STEP 1

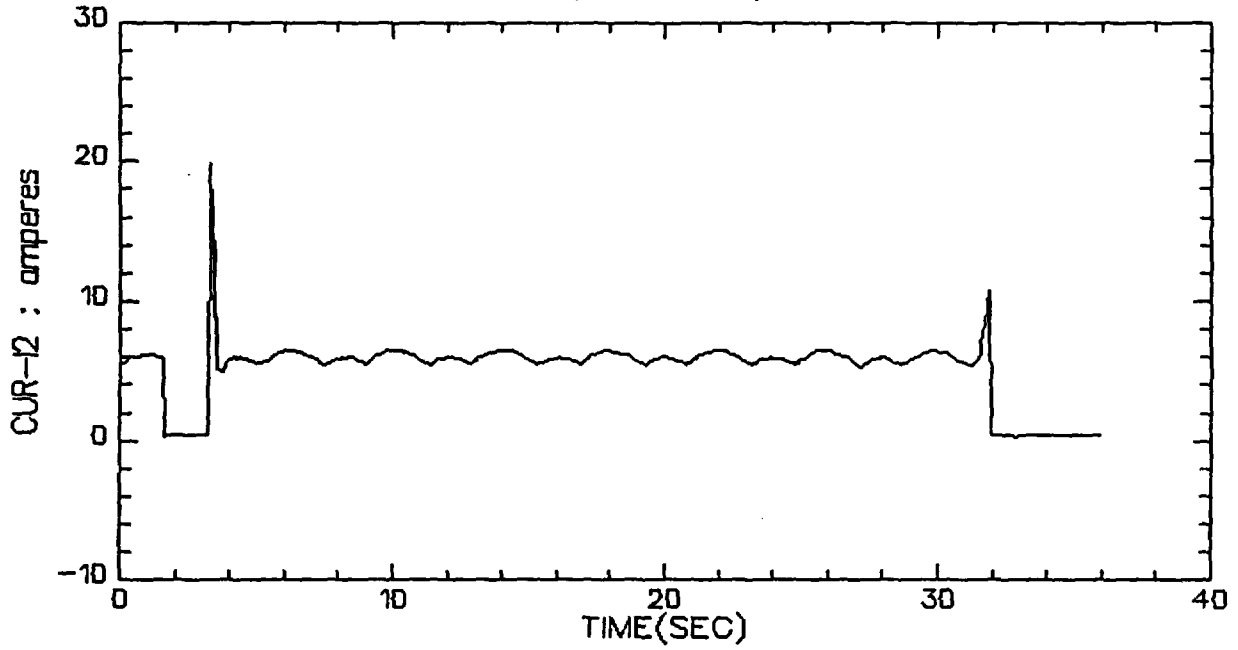

VALVE A, TEST 3, STEP 1

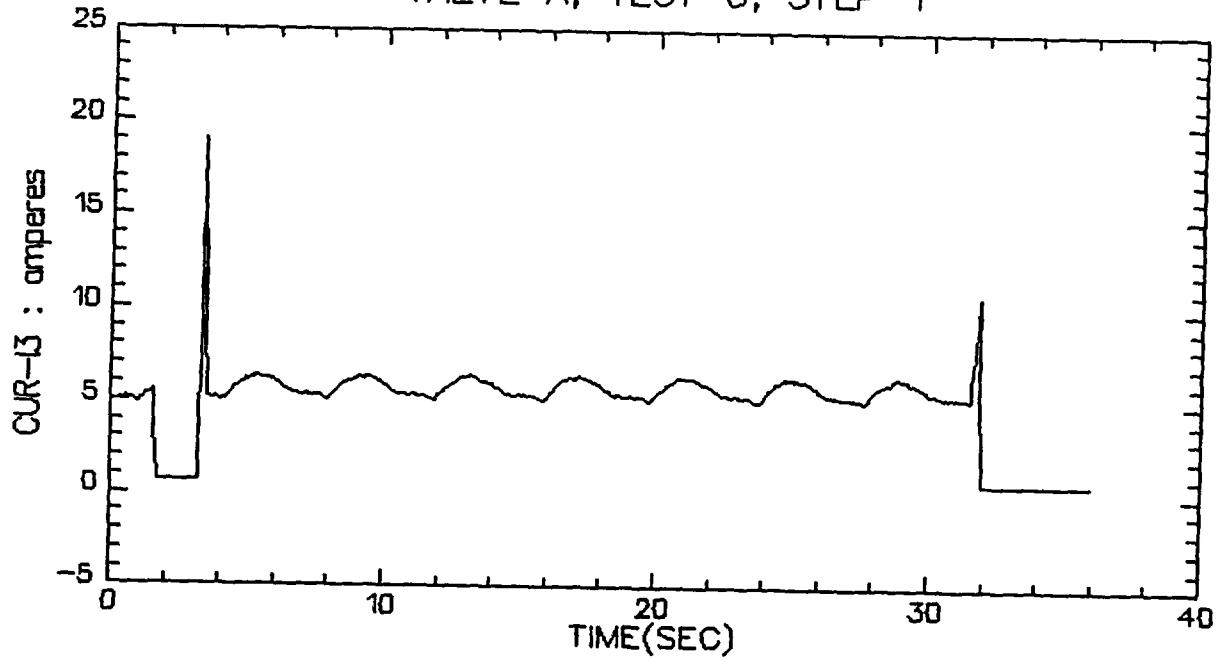

VALVE A, TEST 3, STEP 1

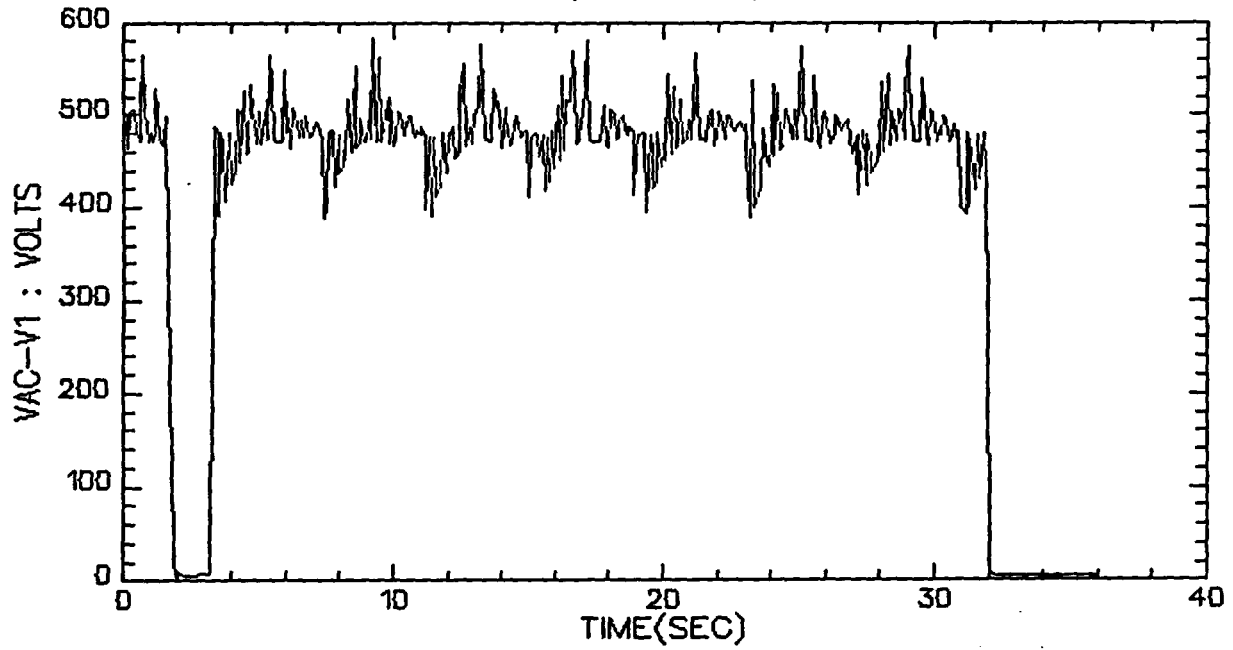

VALVE A, TEST 3, STEP 1

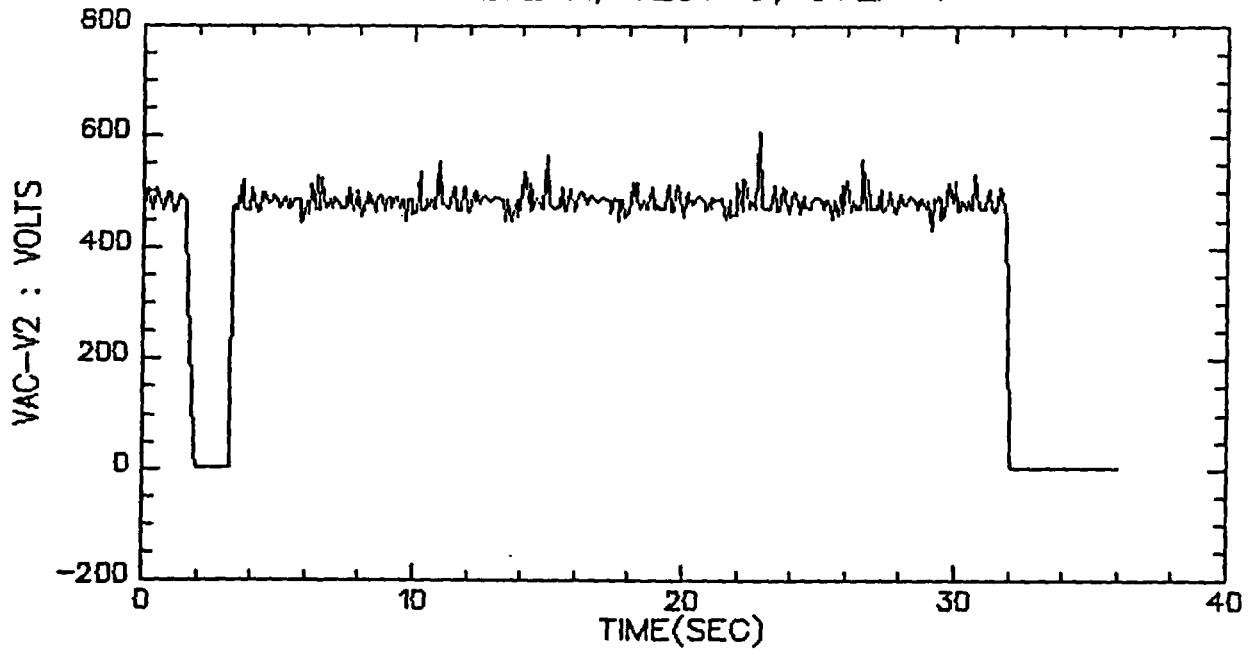

VALVE A, TEST 3, STEP 1

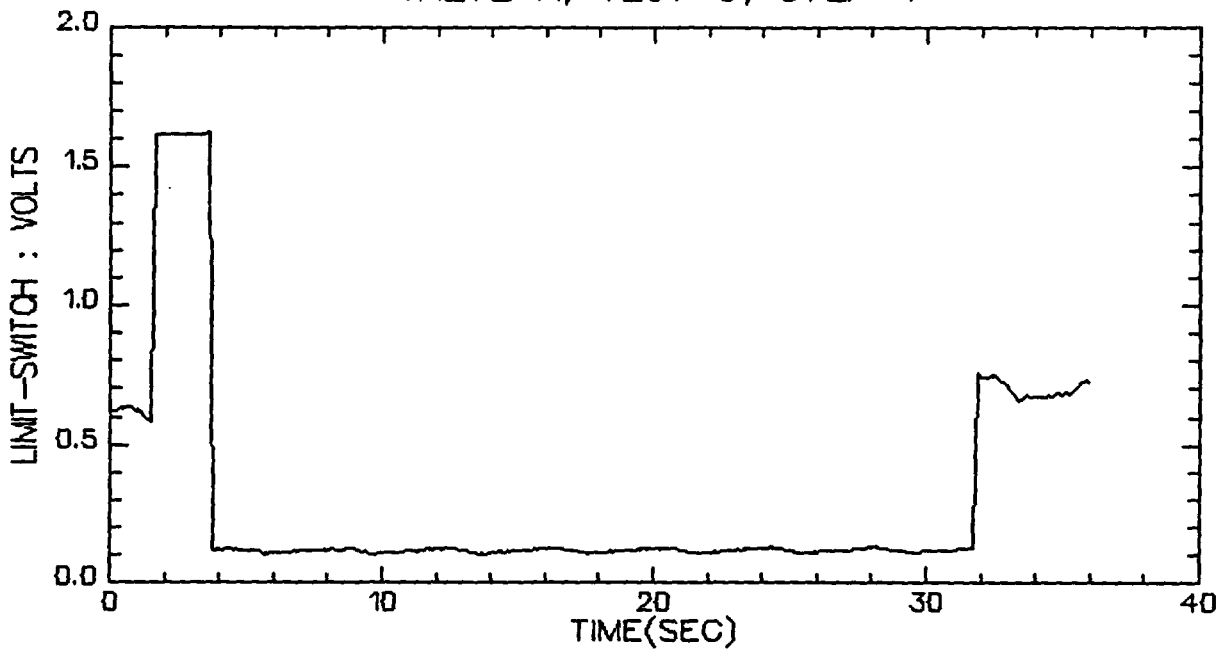

VALVE A, TEST 3, STEP 1

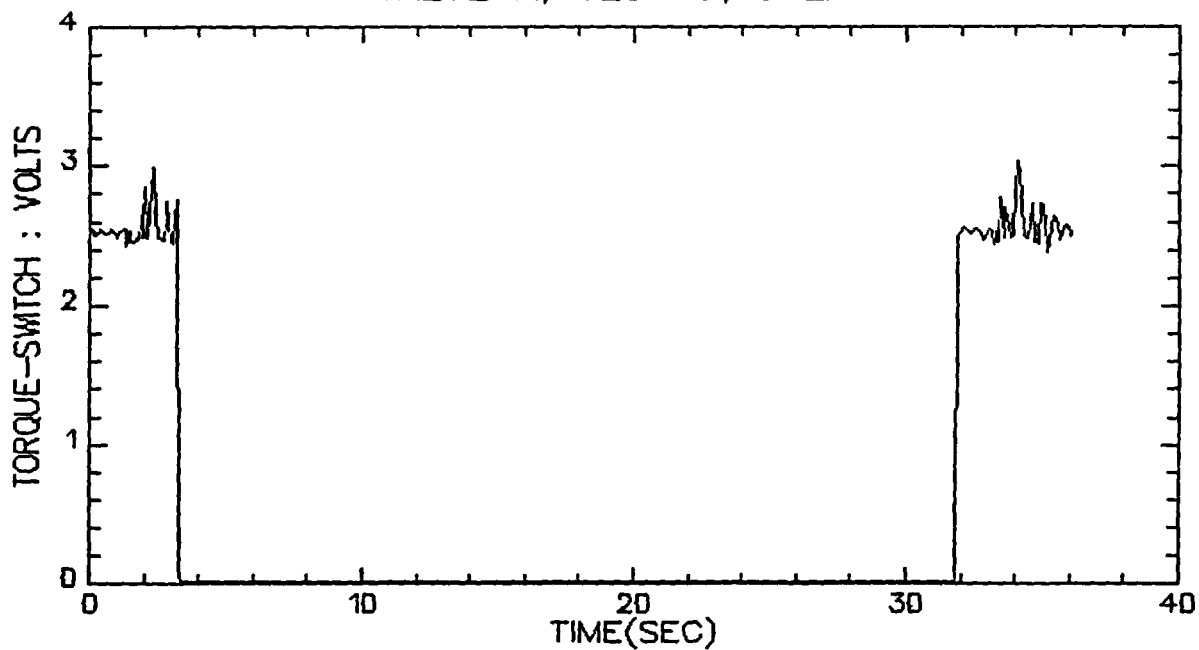

VALVE A, TEST 3, STEP 1

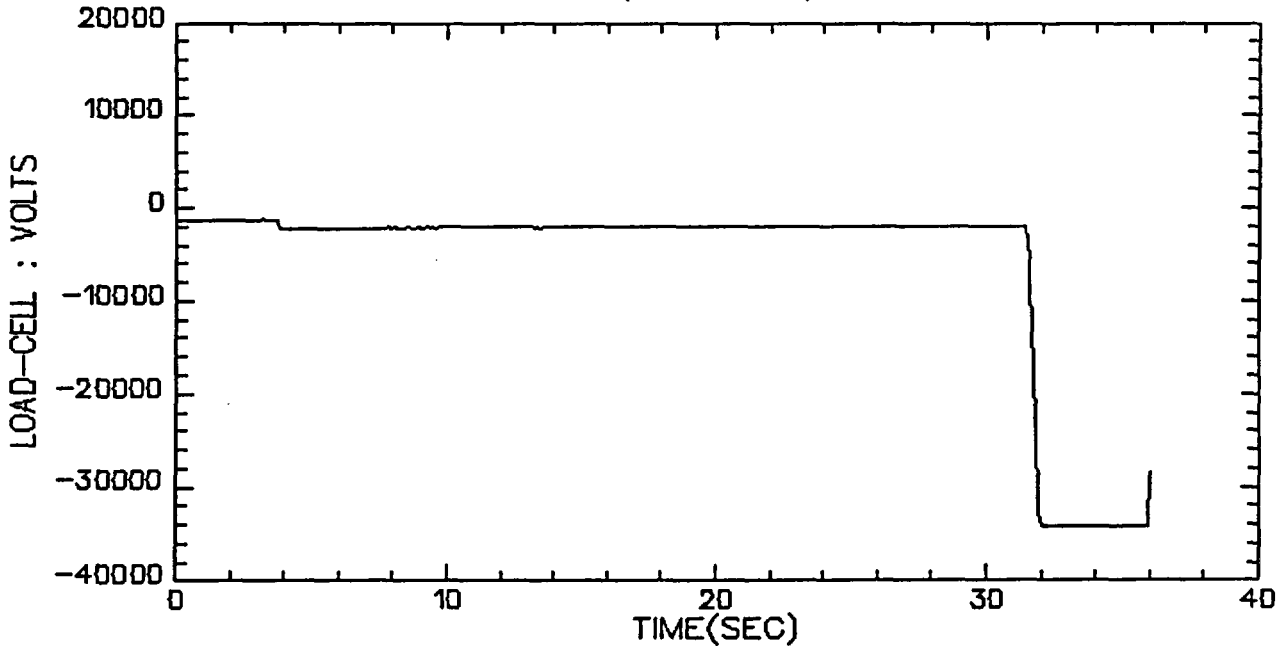

VALVE A, TEST 3, STEP 2

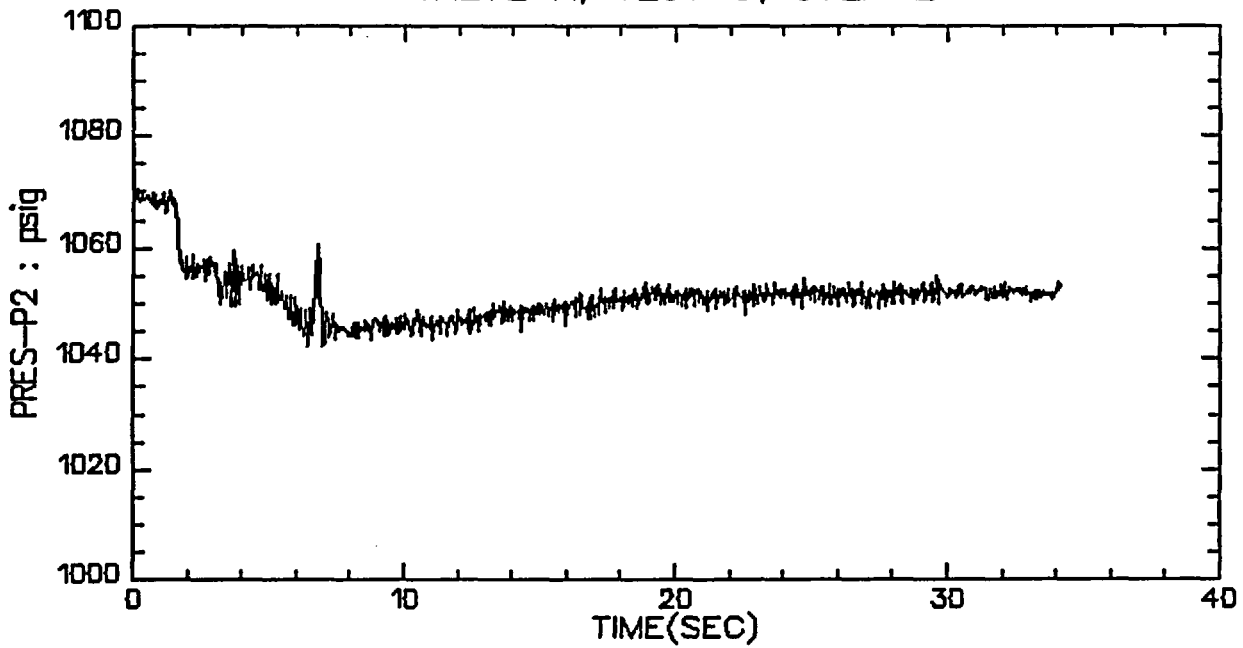

VALVE A, TEST 3, STEP 2

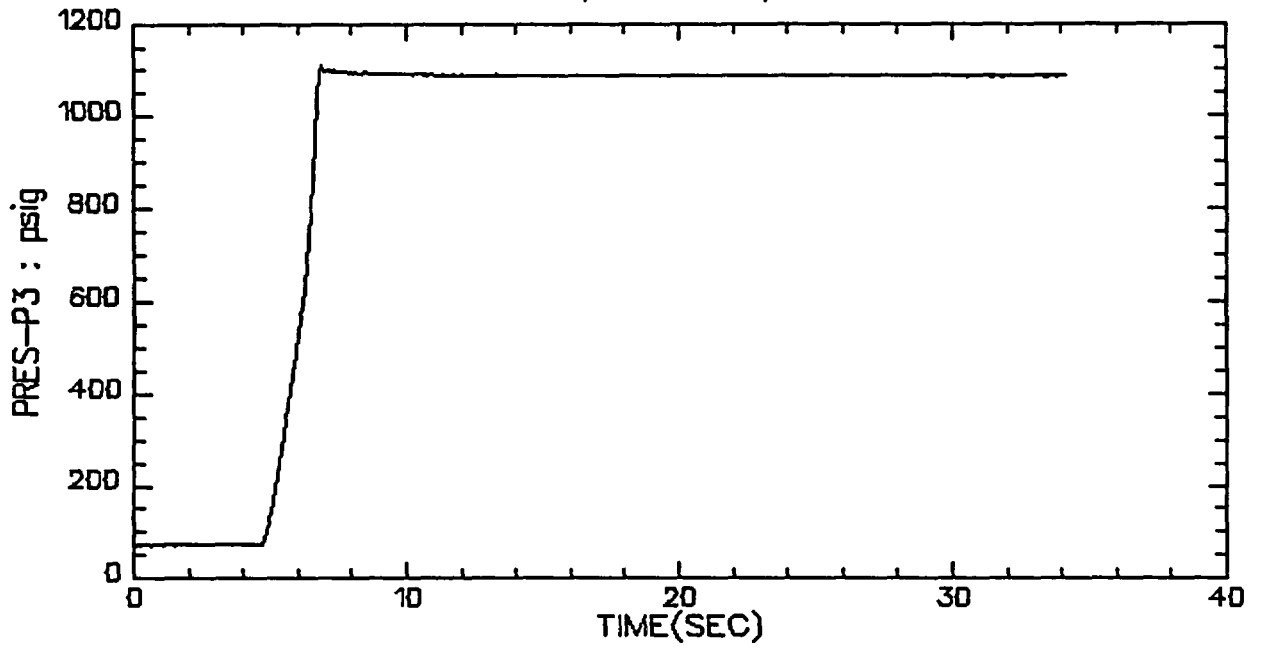

VALVE A, TEST 3, STEP 2

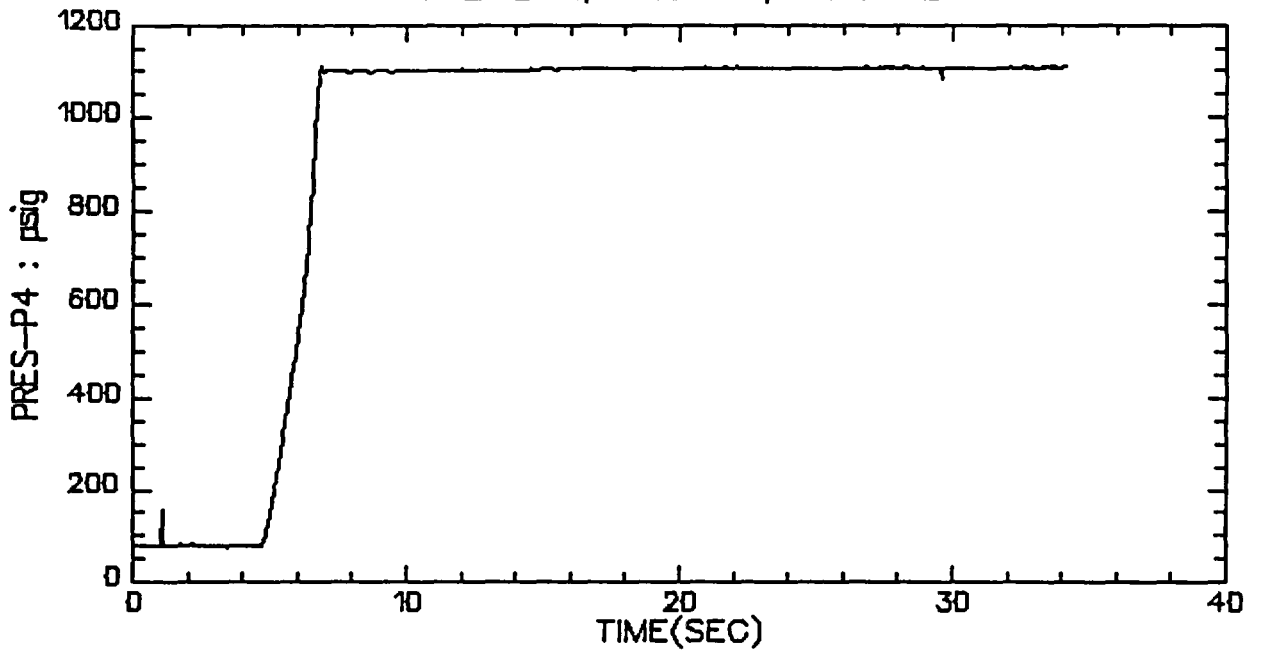

VALVE A, TEST 3, STEP 2

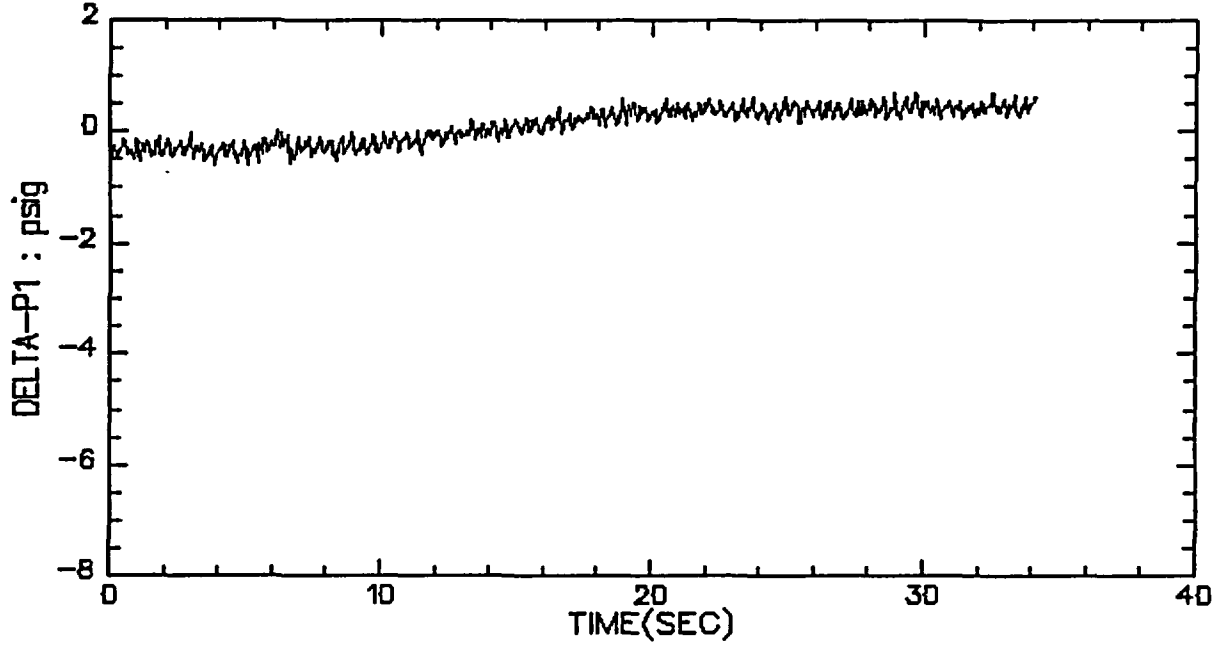

VALVE A, TEST 3, STEP 2

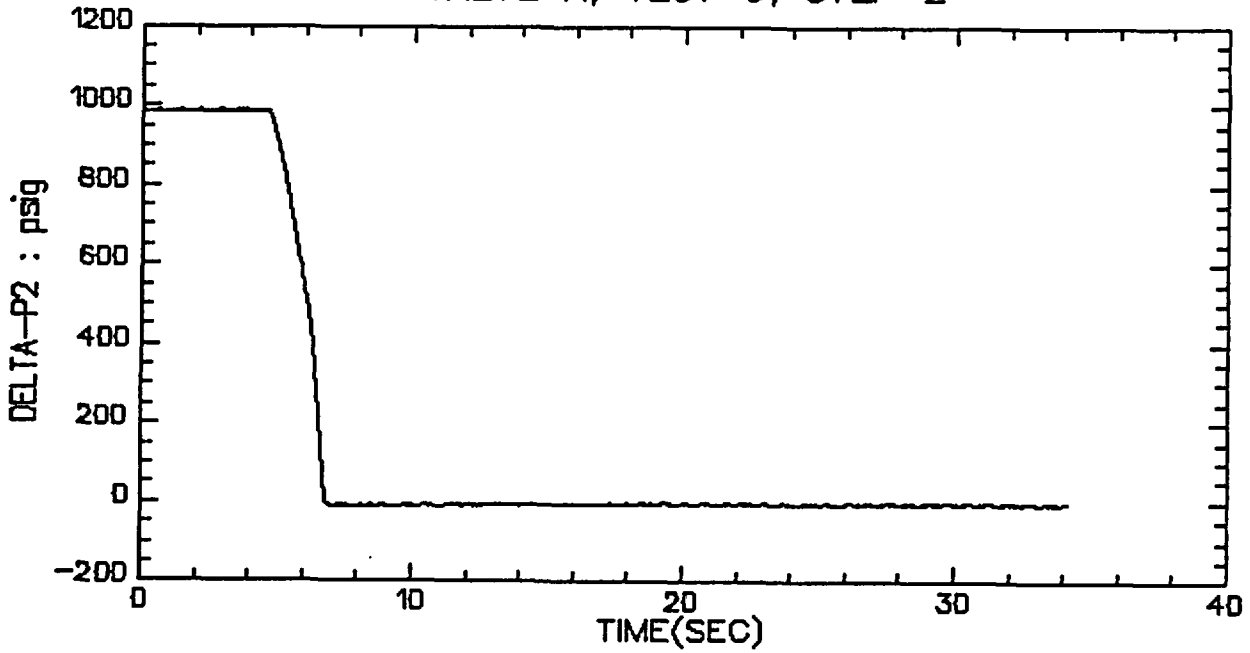

VALVE A, TEST 3, STEP 2

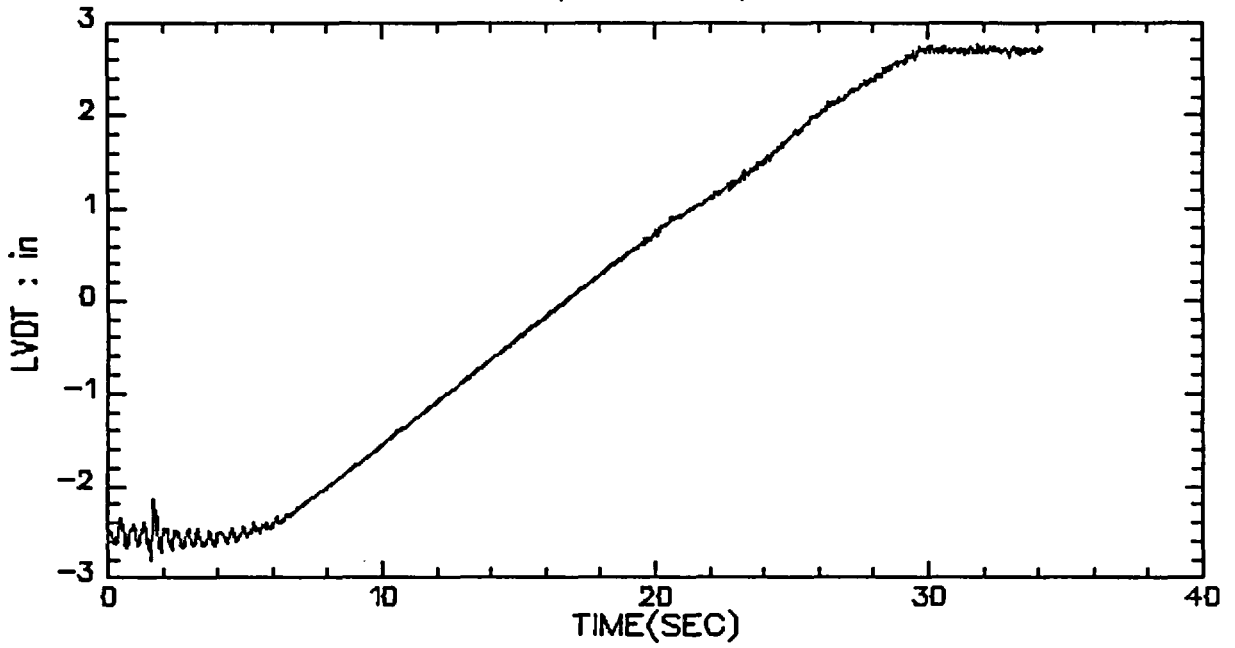

VALVE A, TEST 3, STEP 2

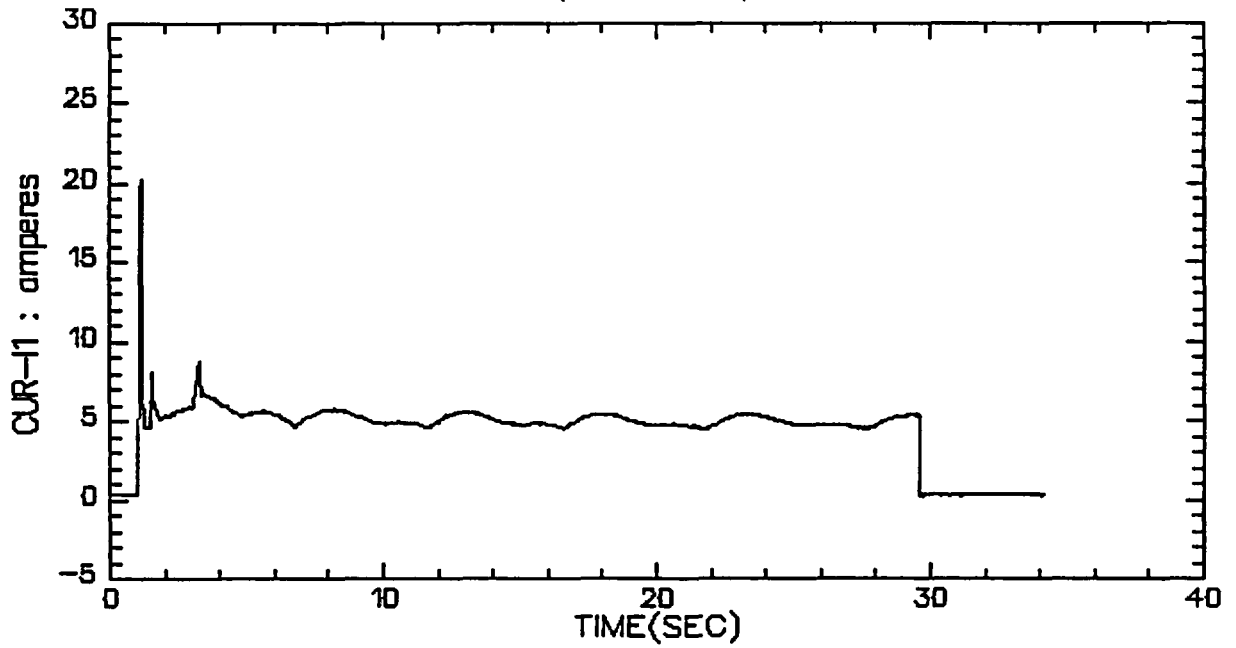

VALVE A, TEST 3, STEP 2

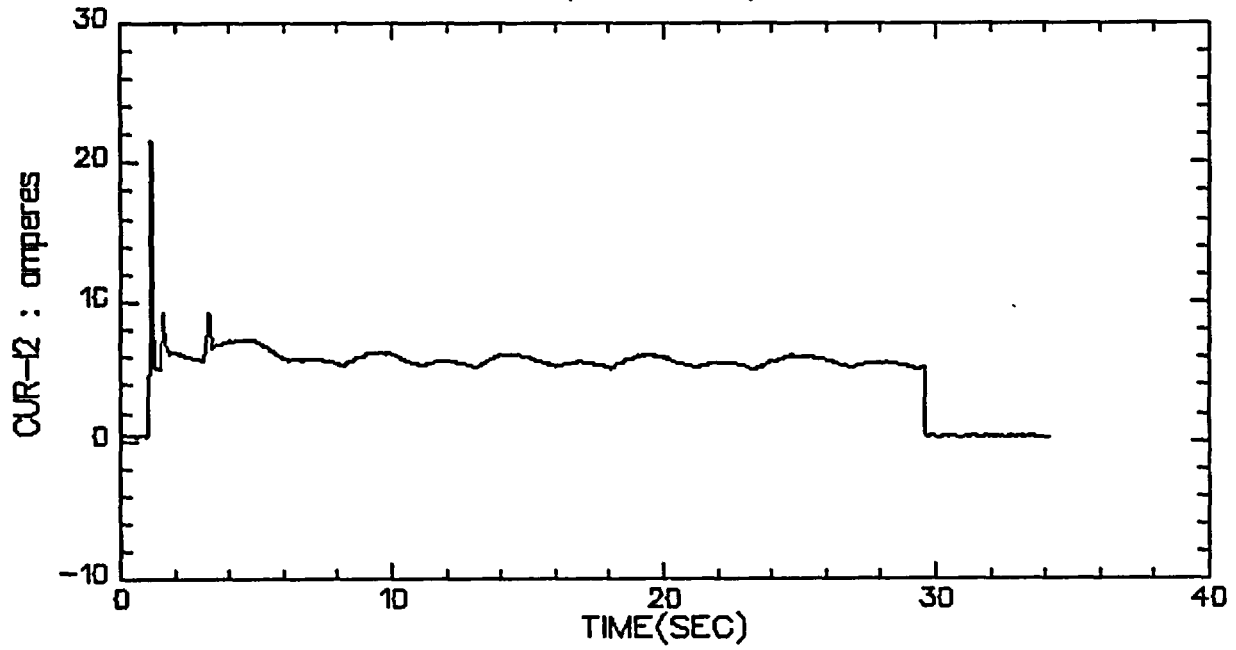

VALVE A, TEST 3, STEP 2

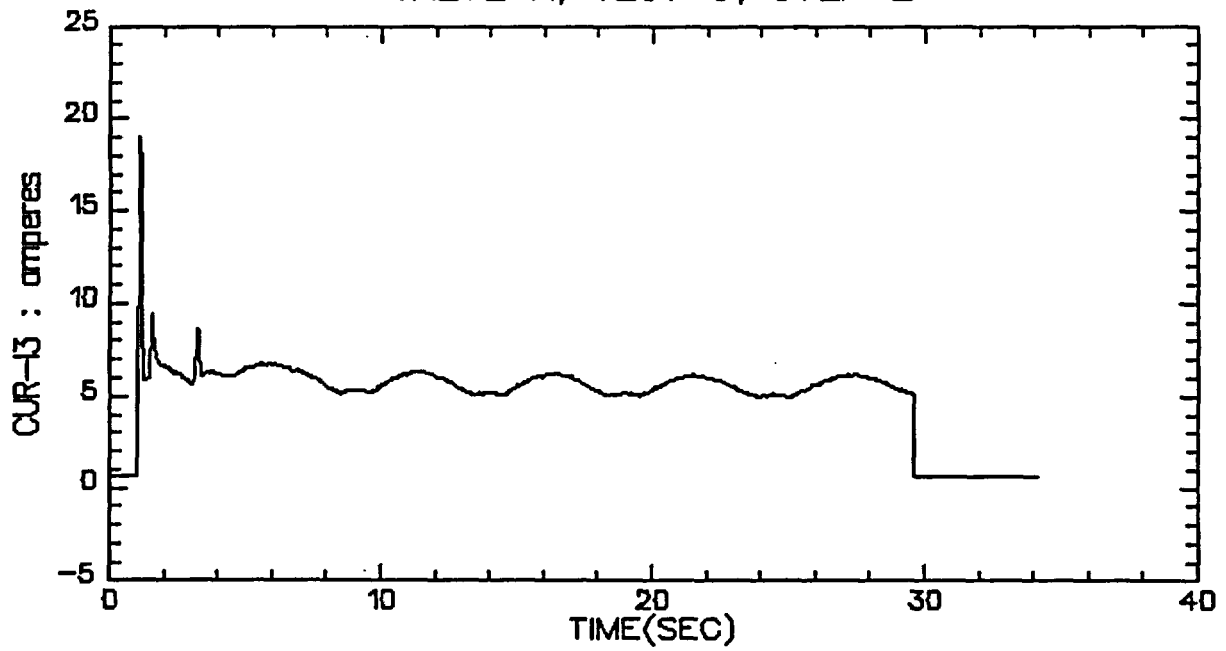

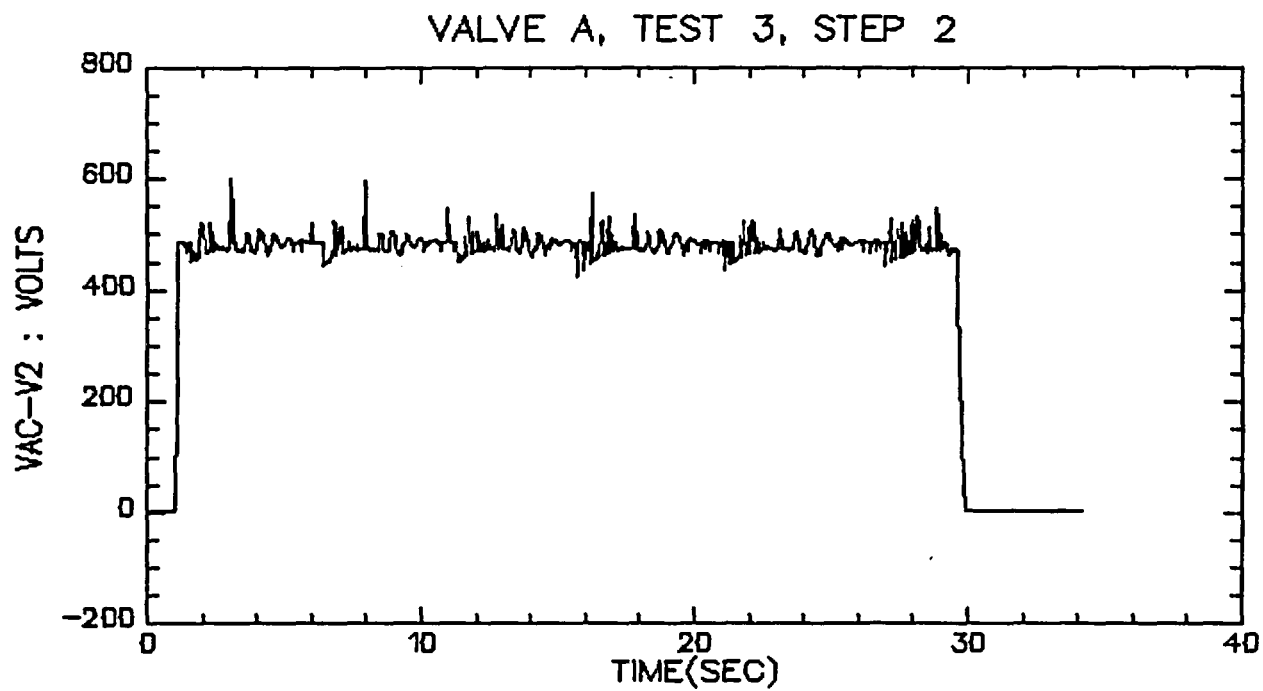
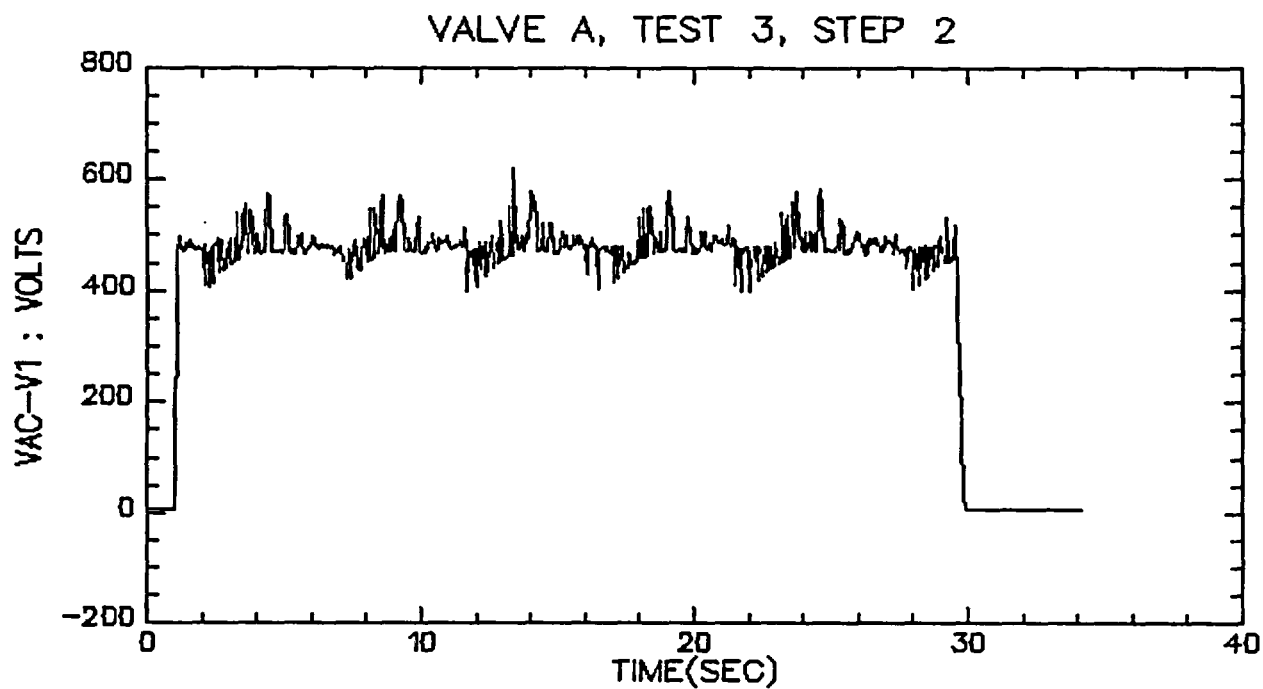

VALVE A, TEST 3, STEP 2

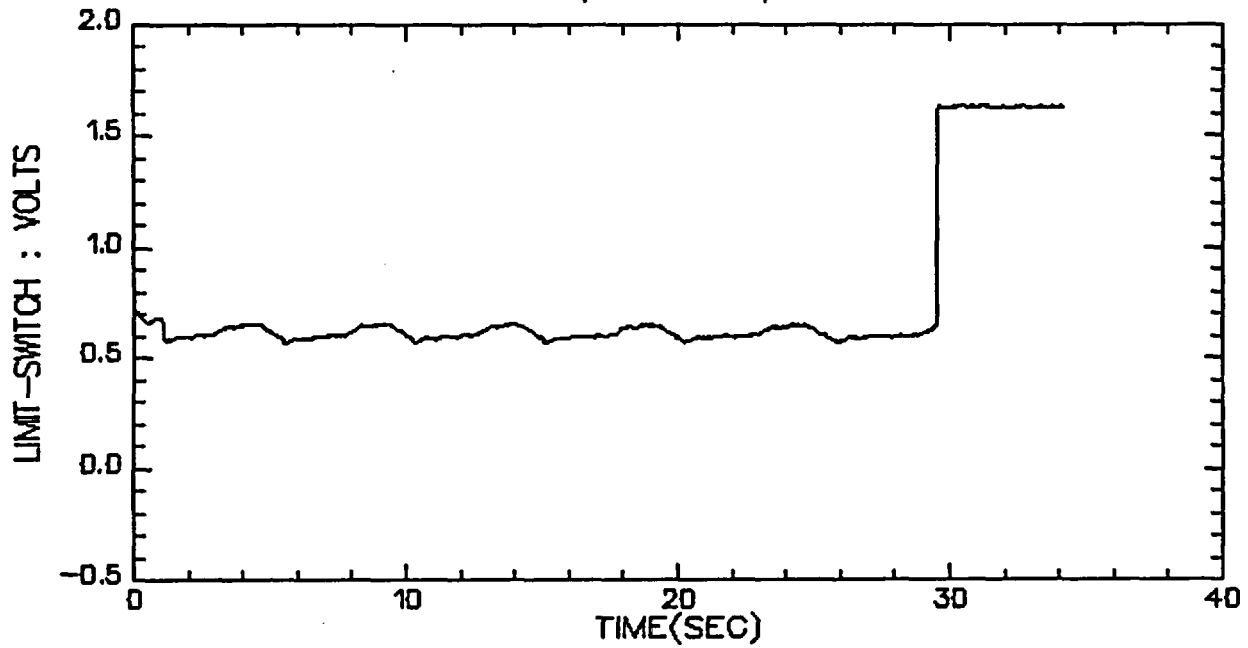

VALVE A, TEST 3, STEP 2

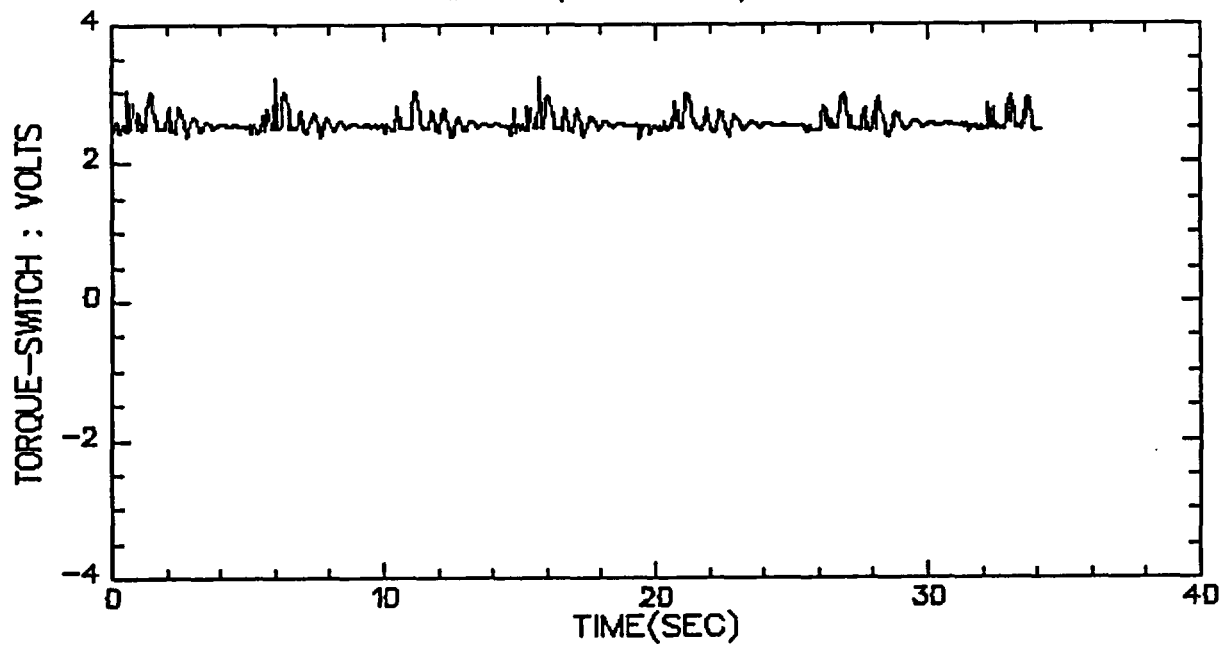

VALVE A, TEST 3, STEP 2

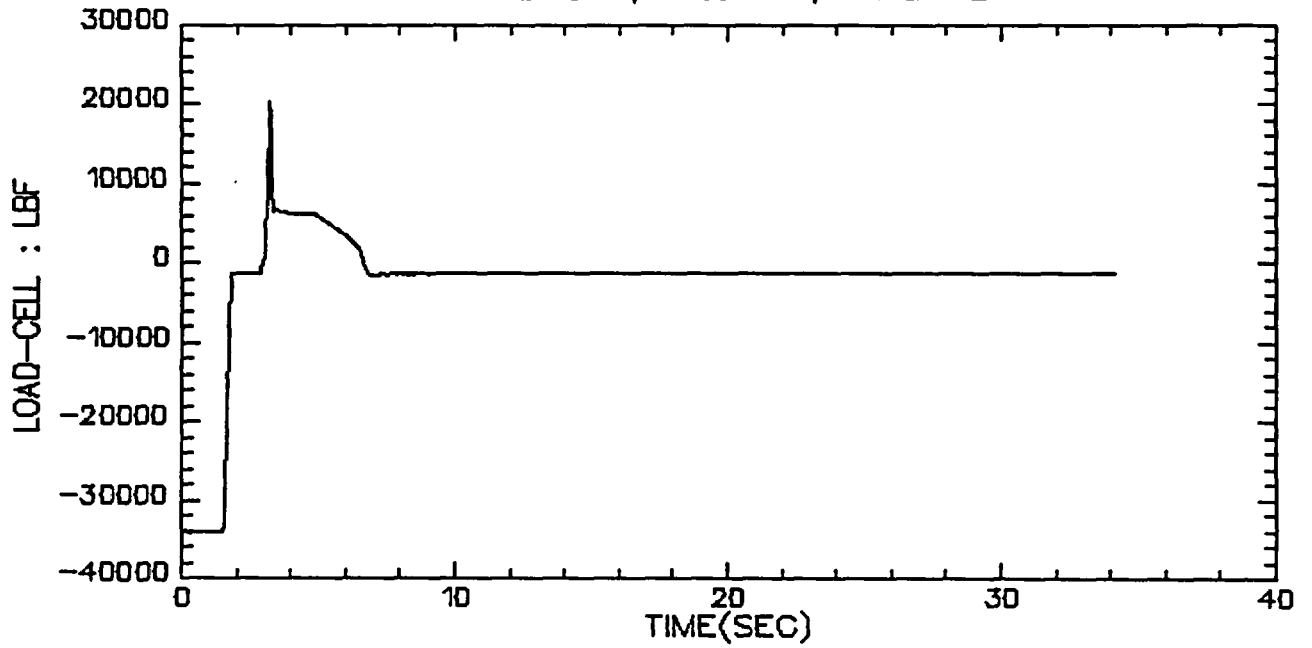

VALVE A, TEST 3, STEP 3&4

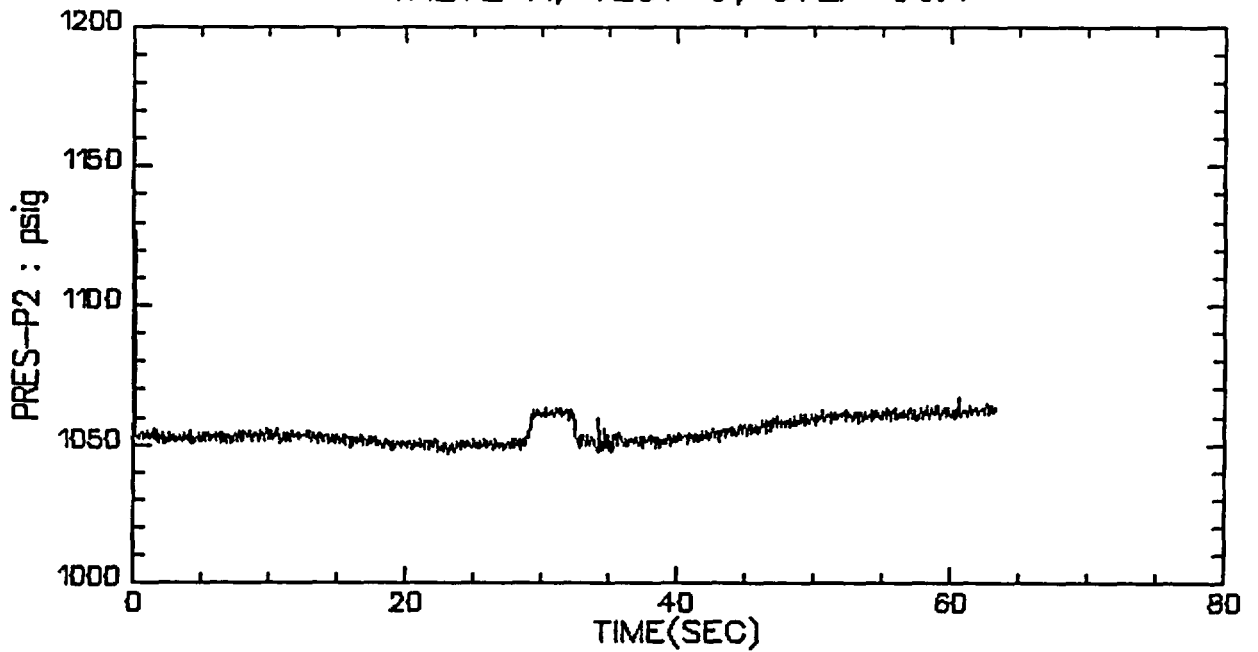

VALVE A, TEST 3, STEP 3&4

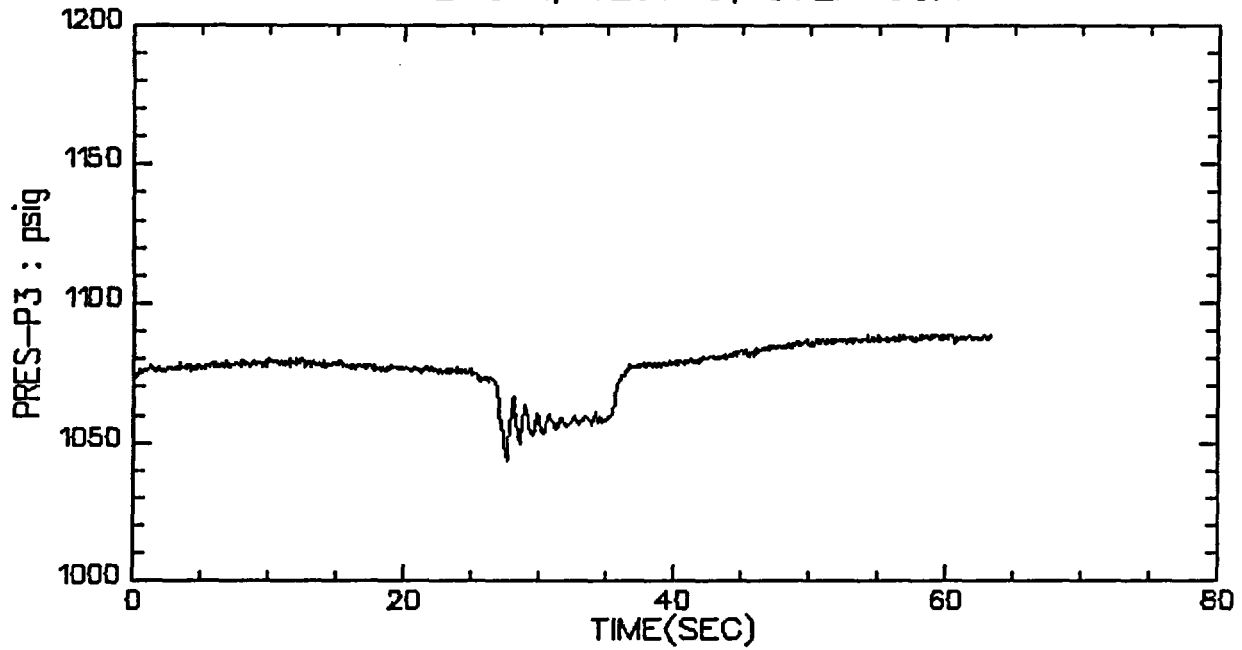

VALVE A, TEST 3, STEP 3&4

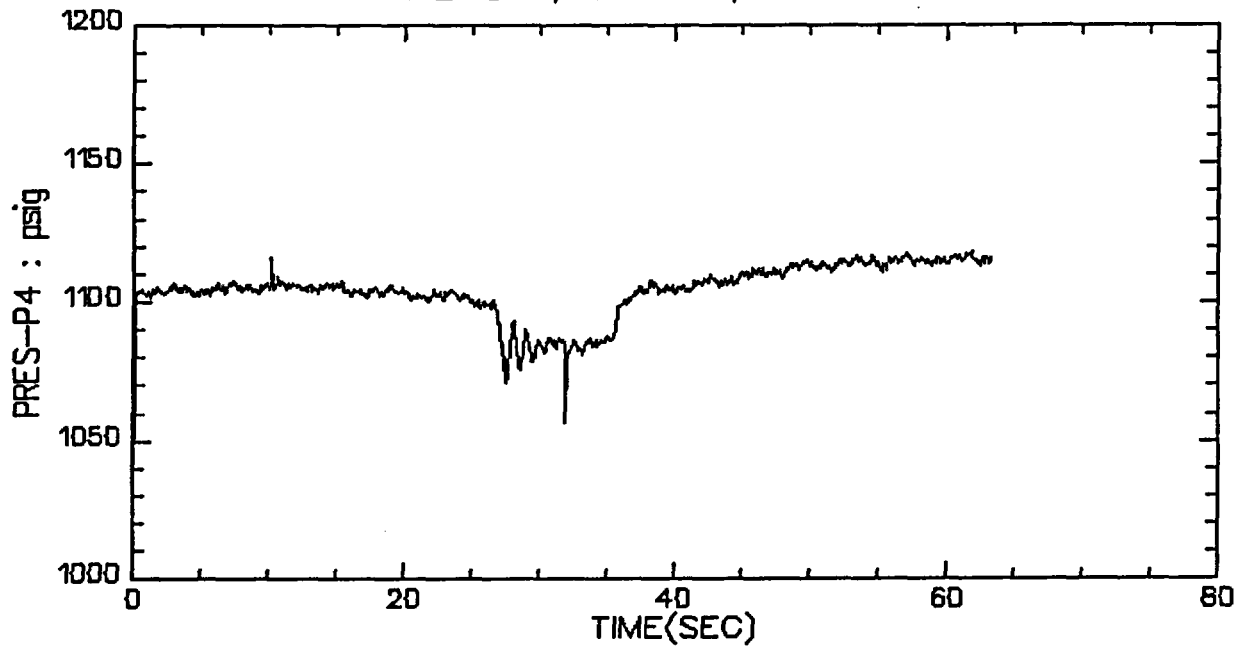

VALVE A, TEST 3, STEP 3&4

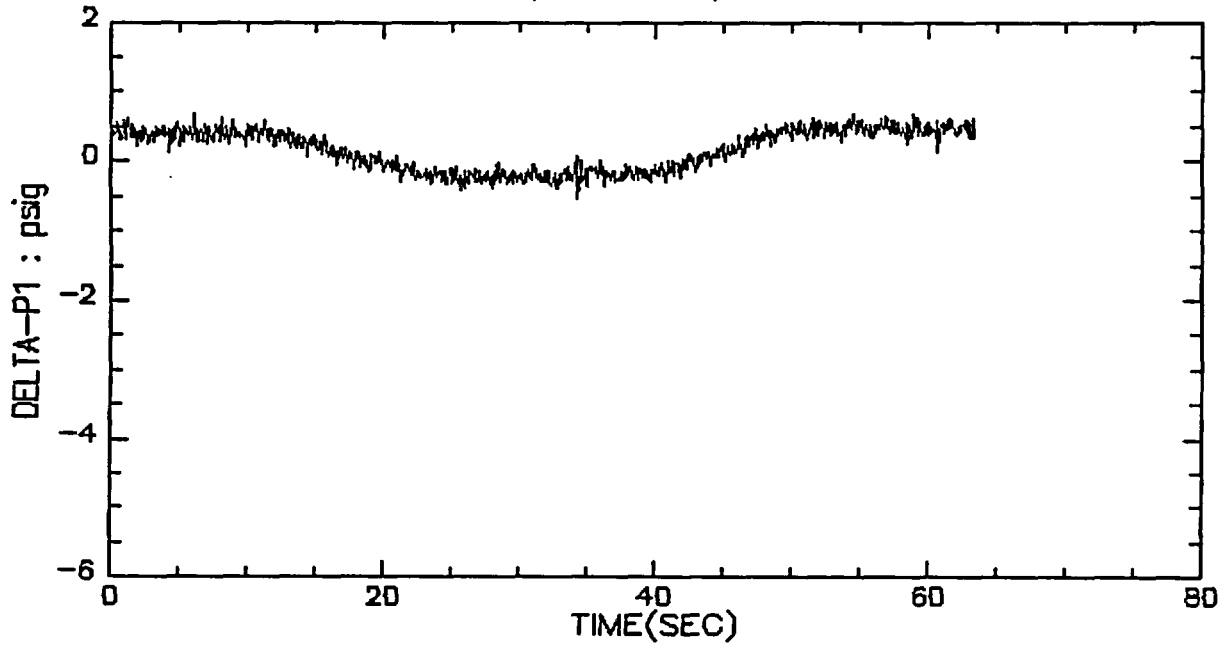

VALVE A, TEST 3, STEP 3&4

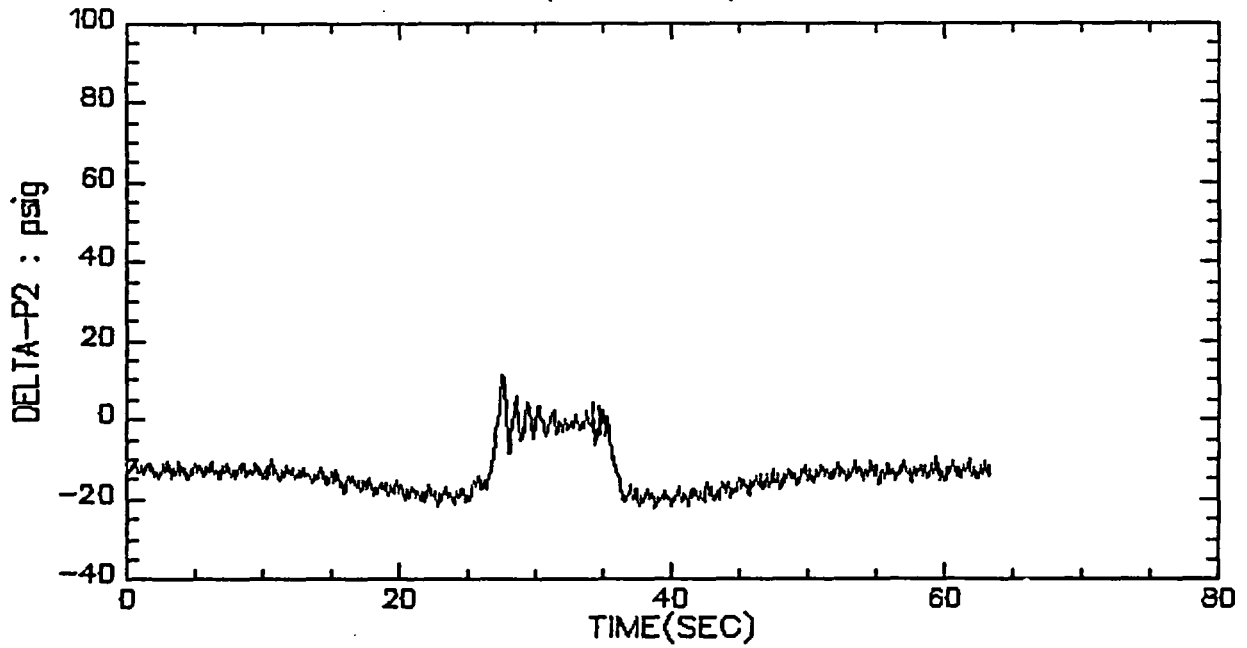

VALVE A, TEST 3, STEP 3&4

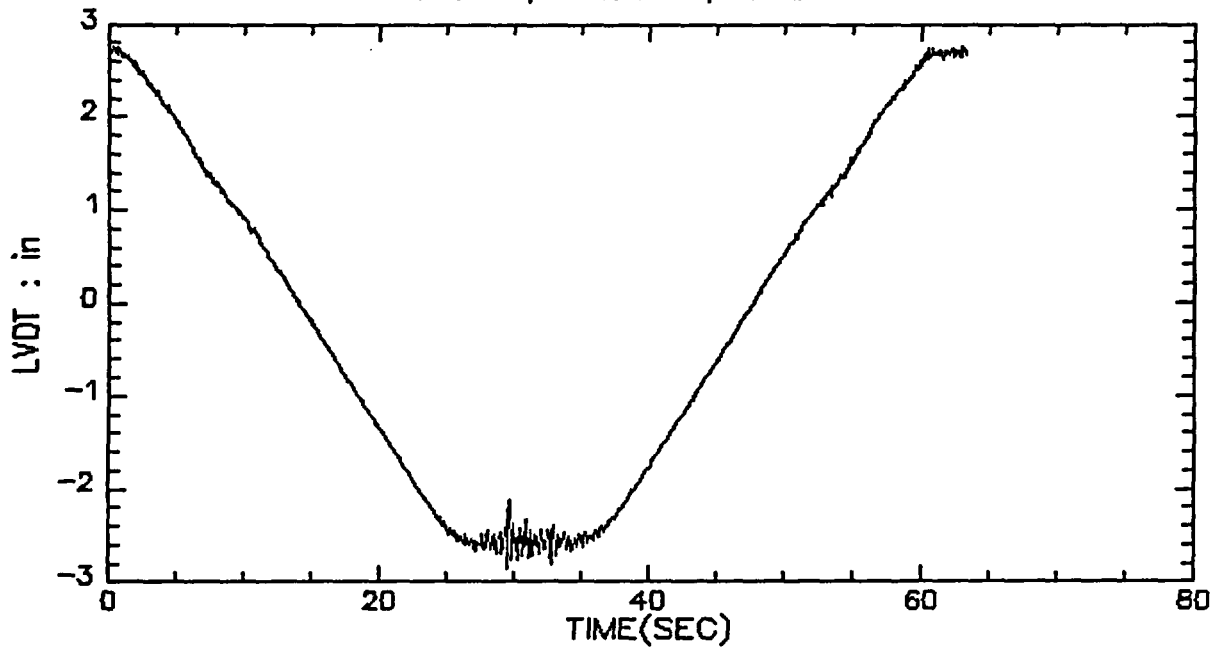

VALVE A, TEST 3, STEP 3&4

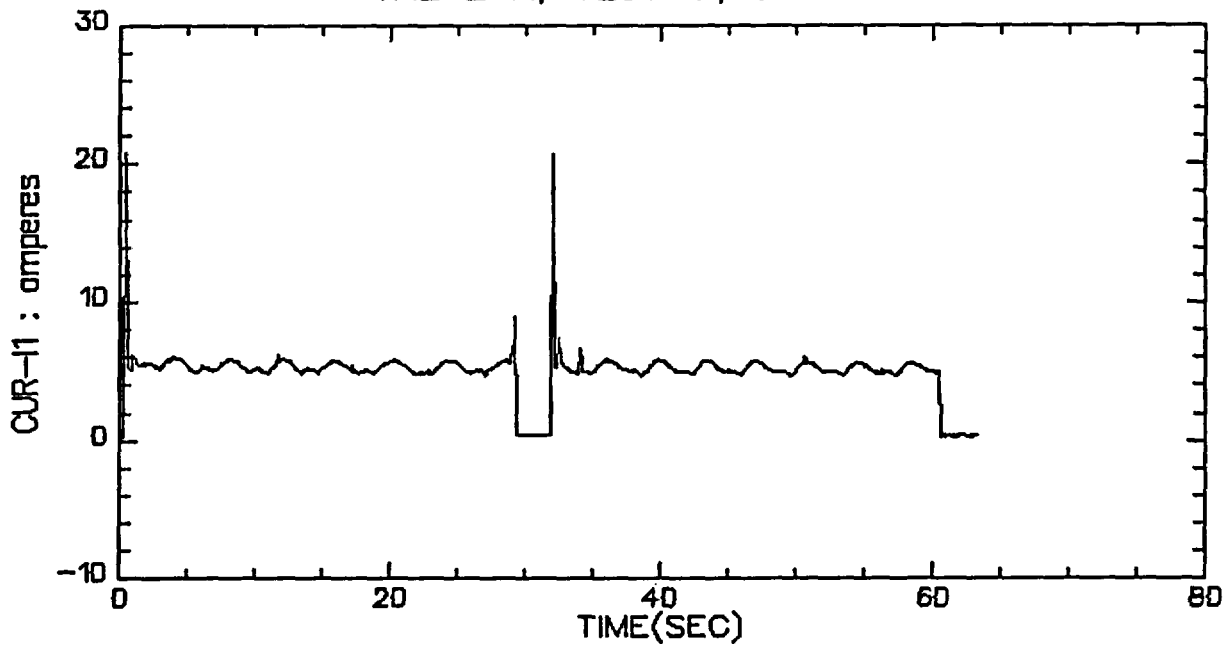

VALVE A, TEST 3, STEP 3&4

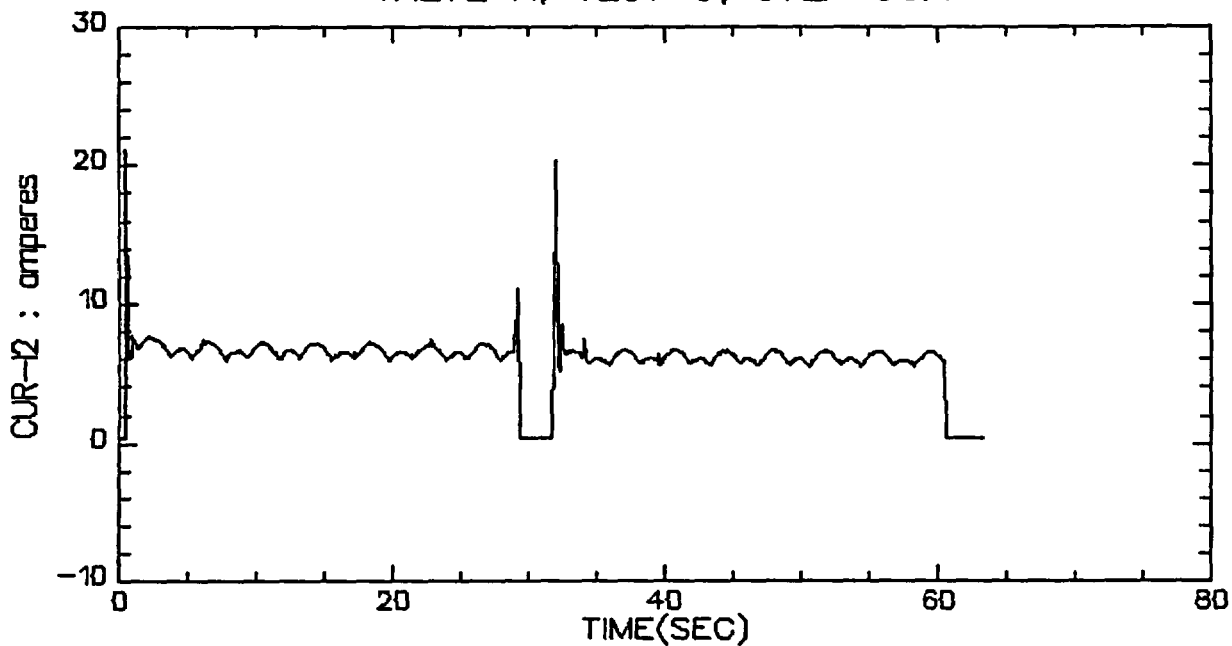

VALVE A, TEST 3, STEP 3&4

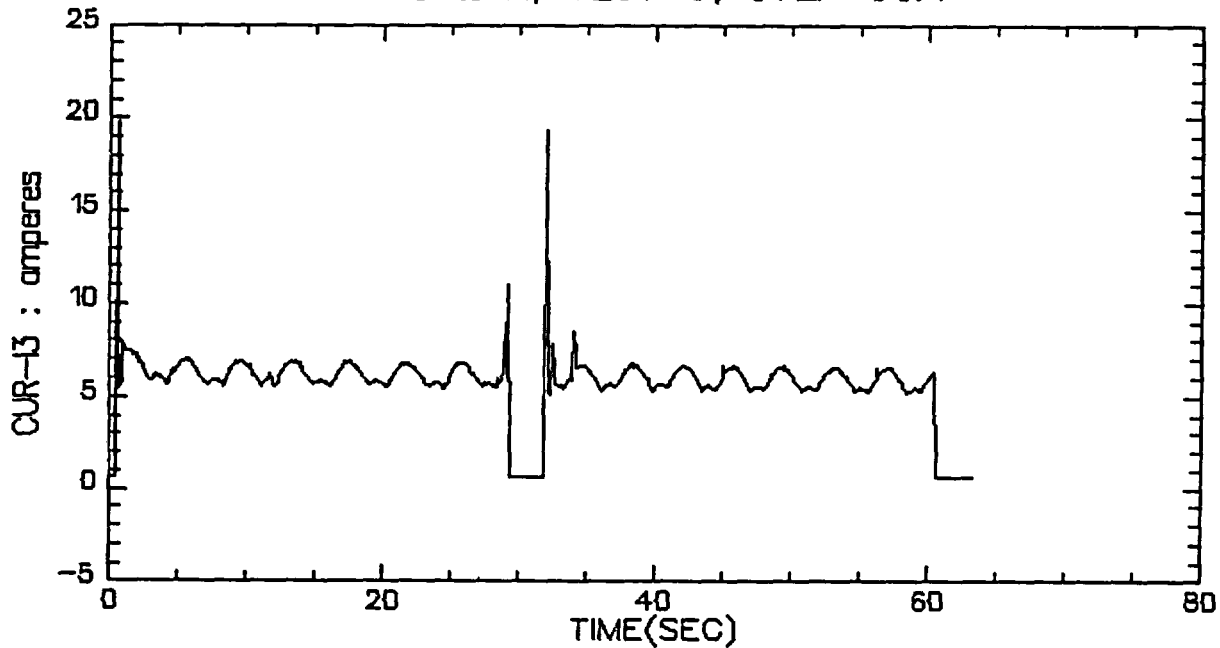

VALVE A, TEST 3, STEP 3&4

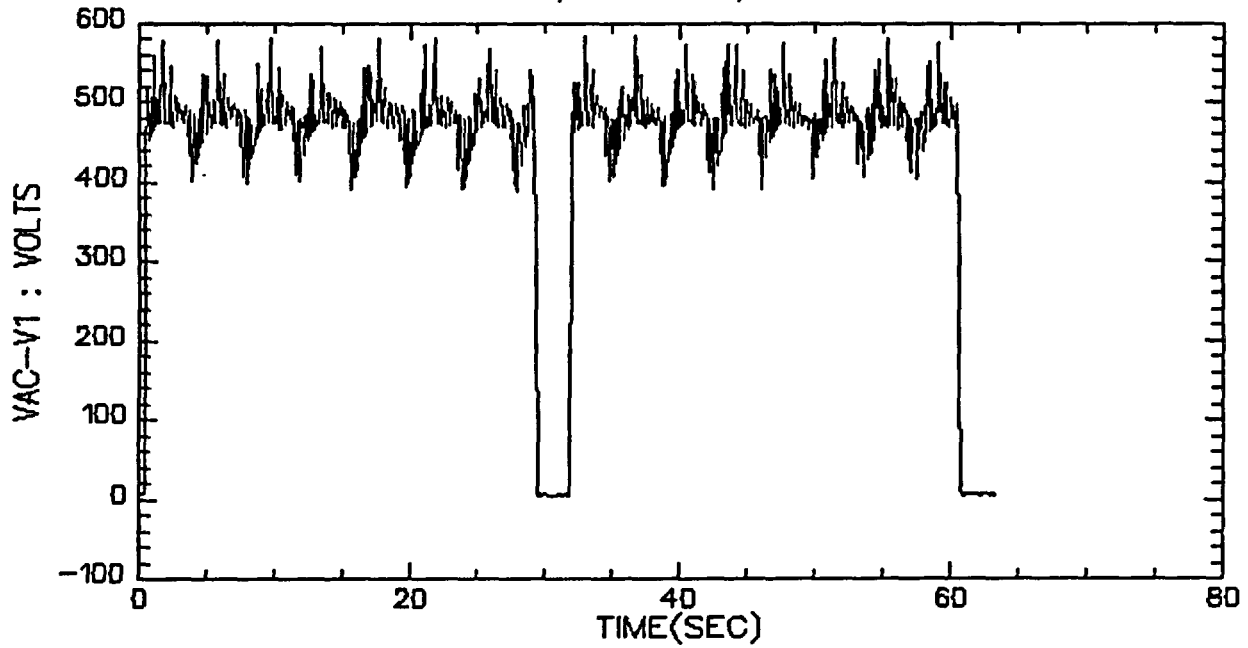

VALVE A, TEST 3, STEP 3&4

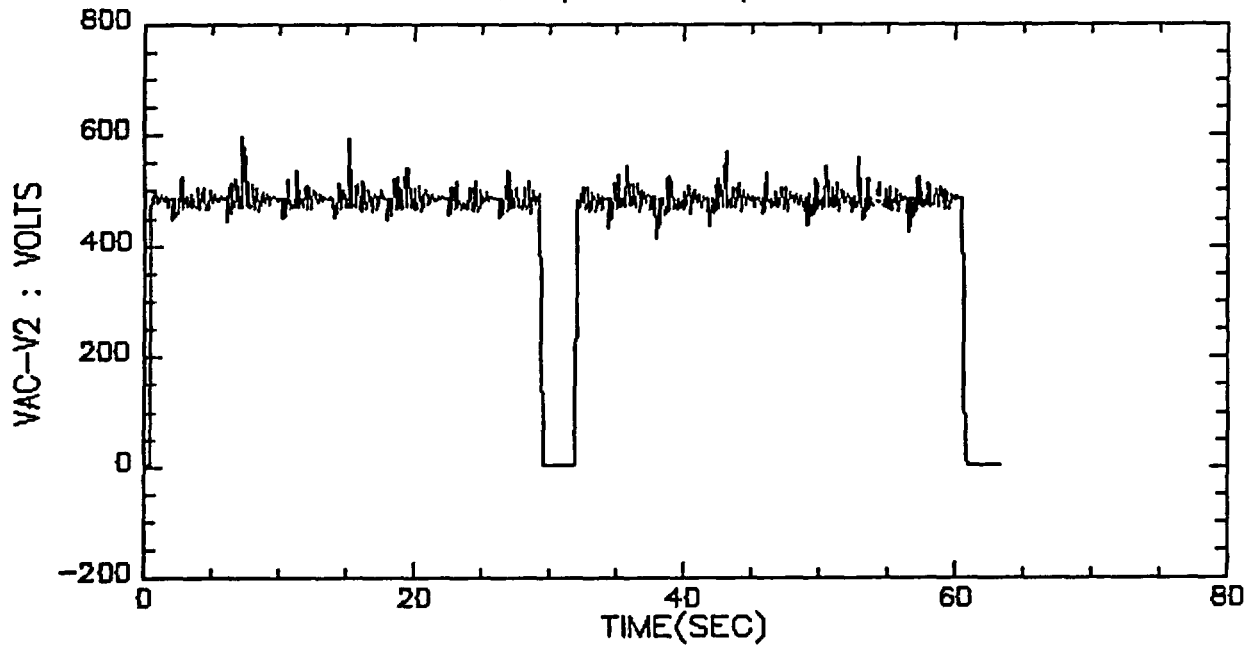

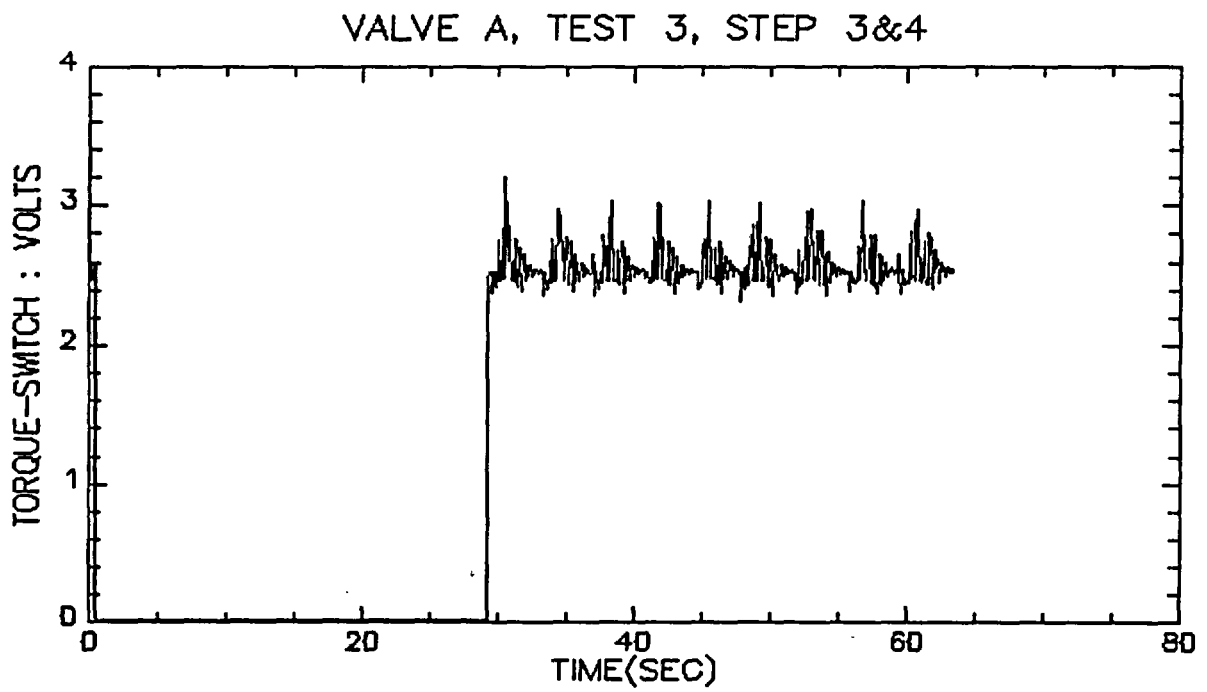
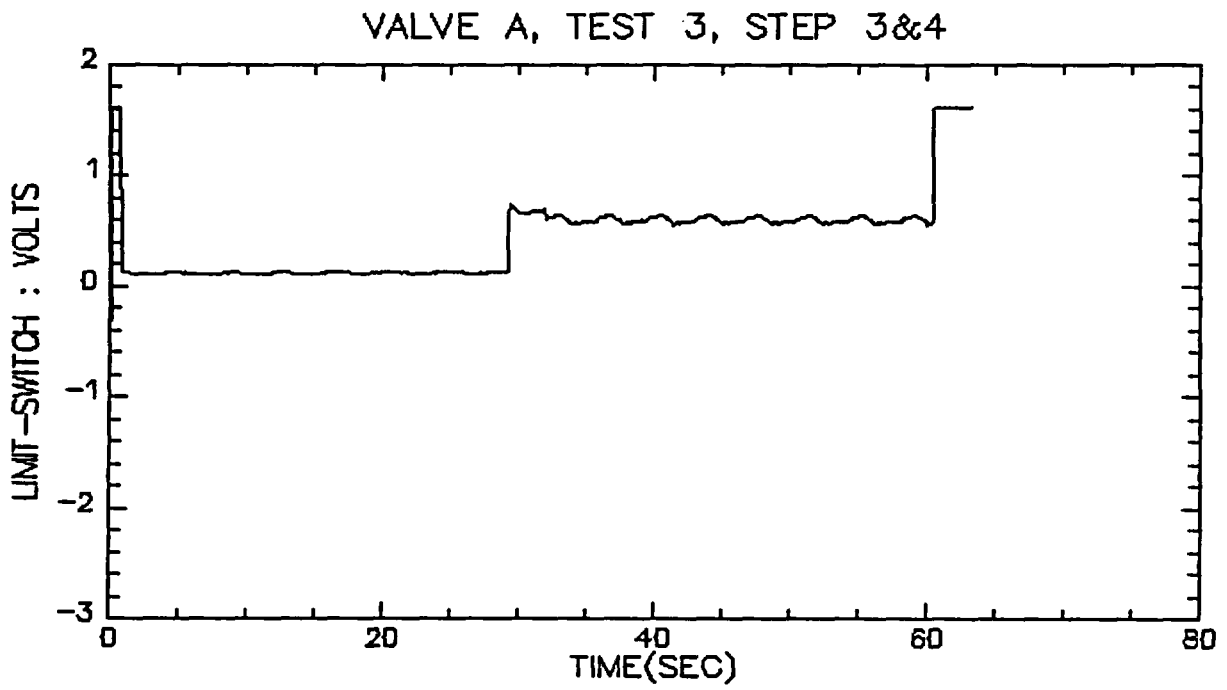

VALVE A, TEST 3, STEP 3&4

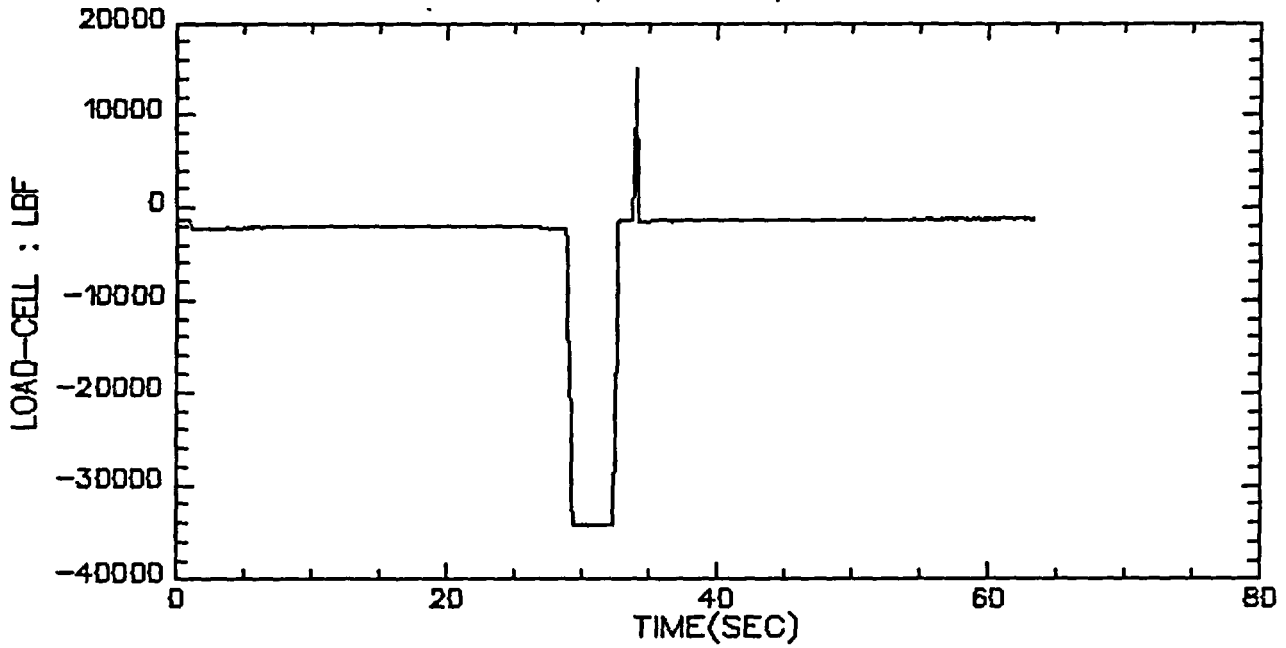

VALVE A, TEST 3, STEP 5

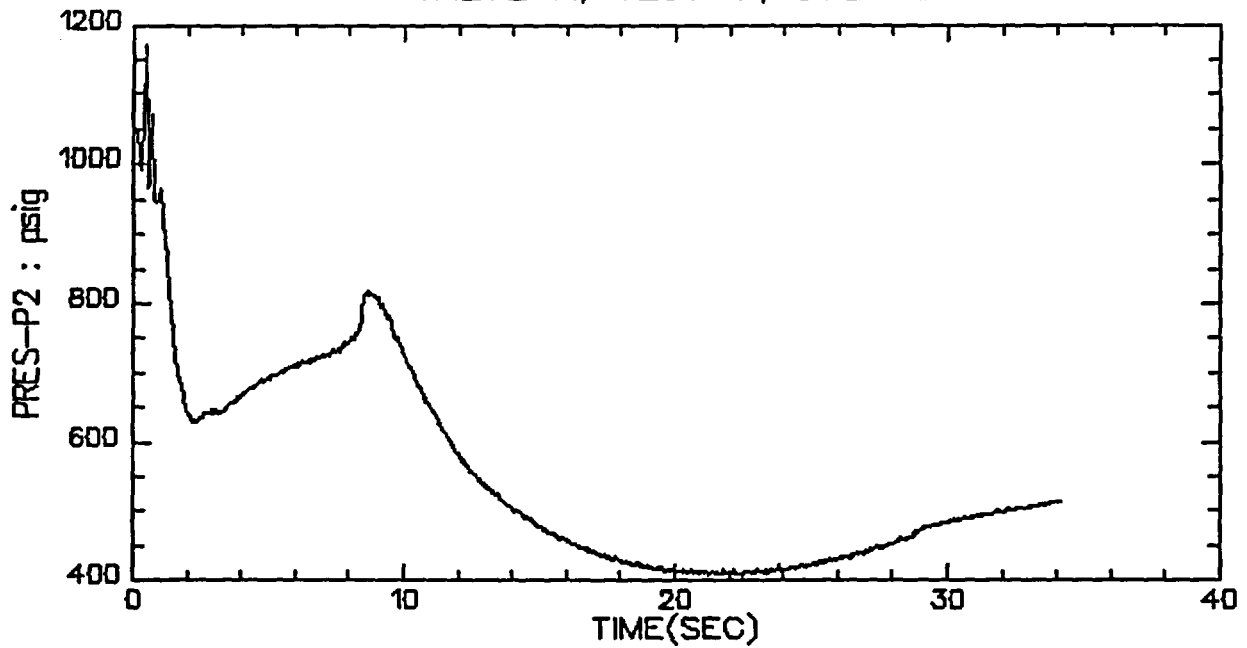

VALVE A, TEST 3, STEP 5

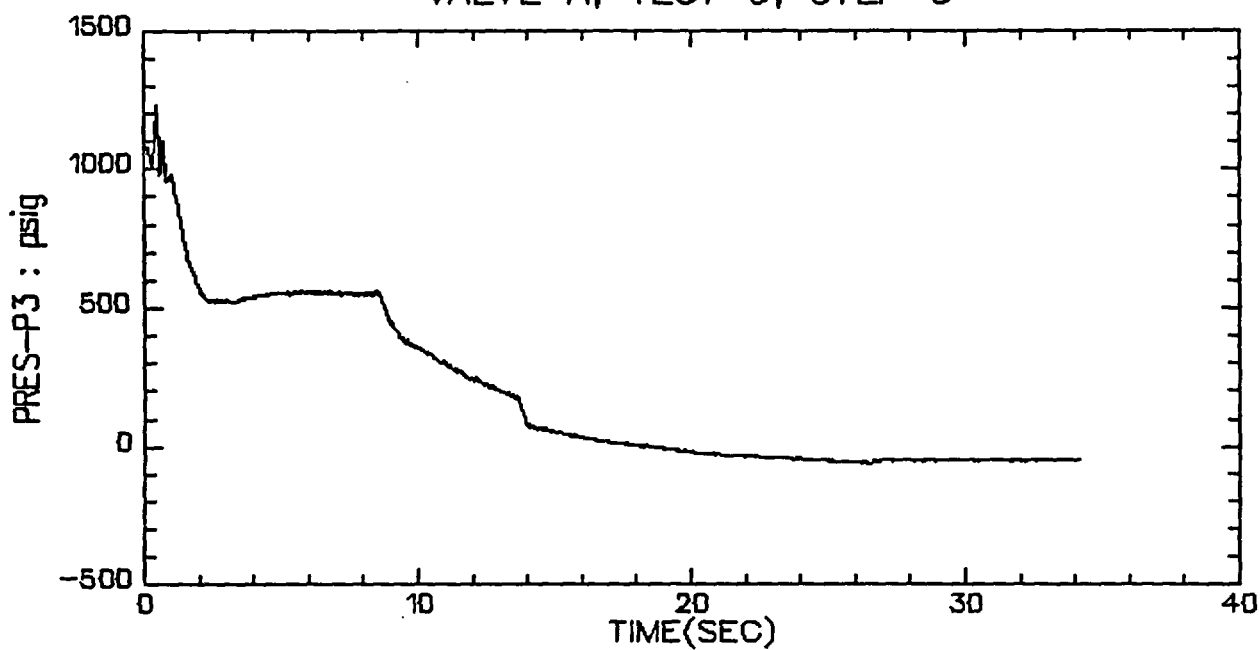

VALVE A, TEST 3, STEP 5

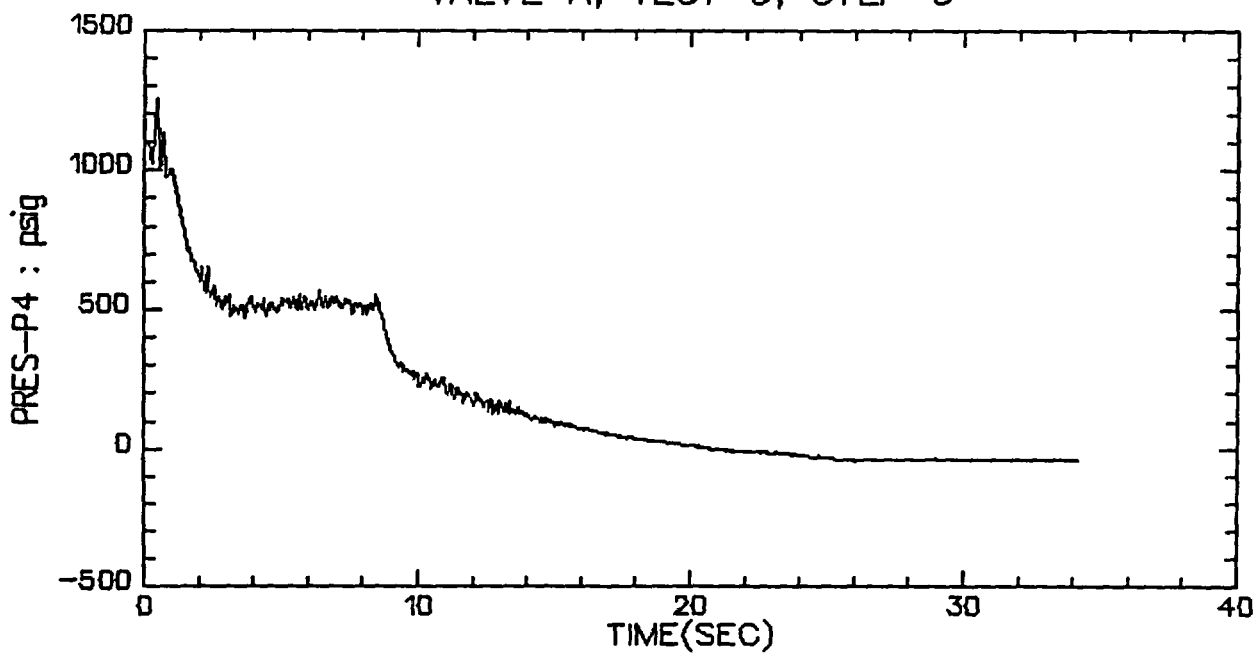

VALVE A, TEST 3, STEP 5

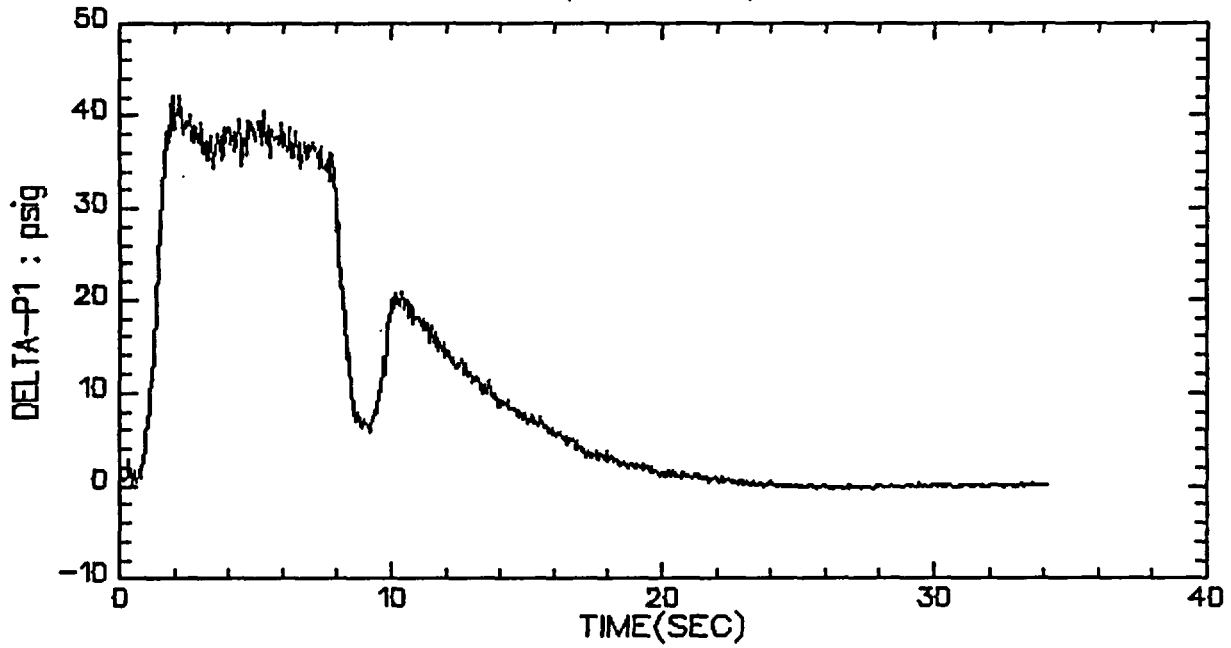

VALVE A, TEST 3, STEP 5

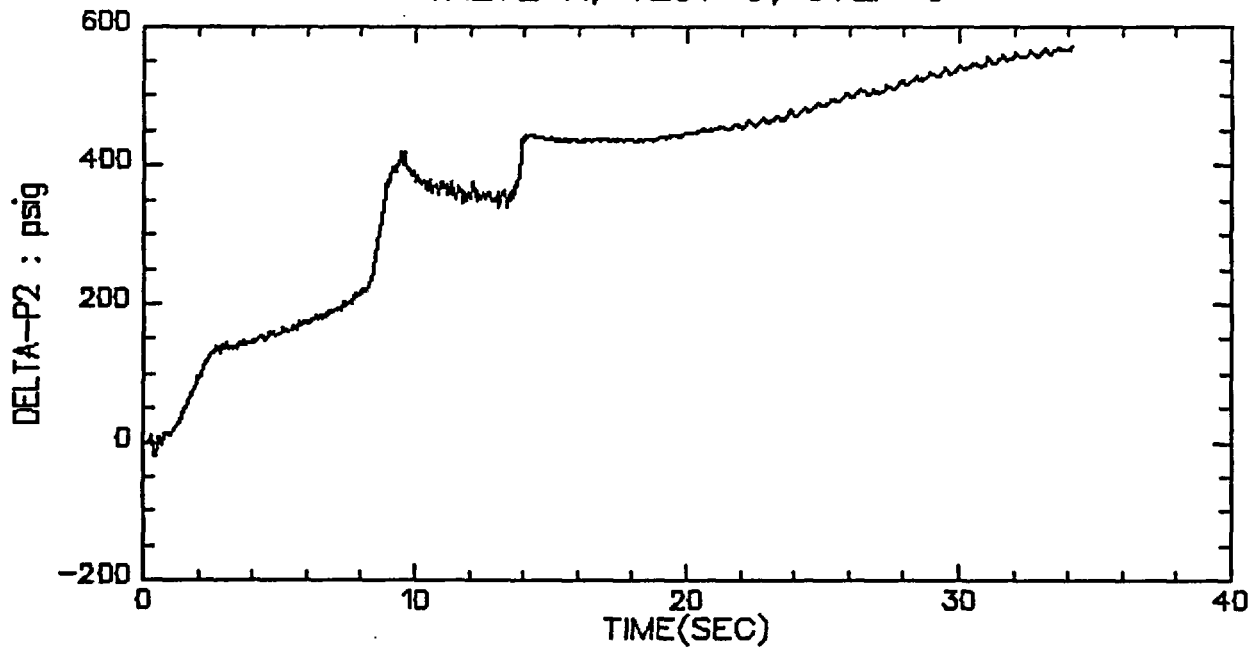

VALVE A, TEST 3, STEP 5

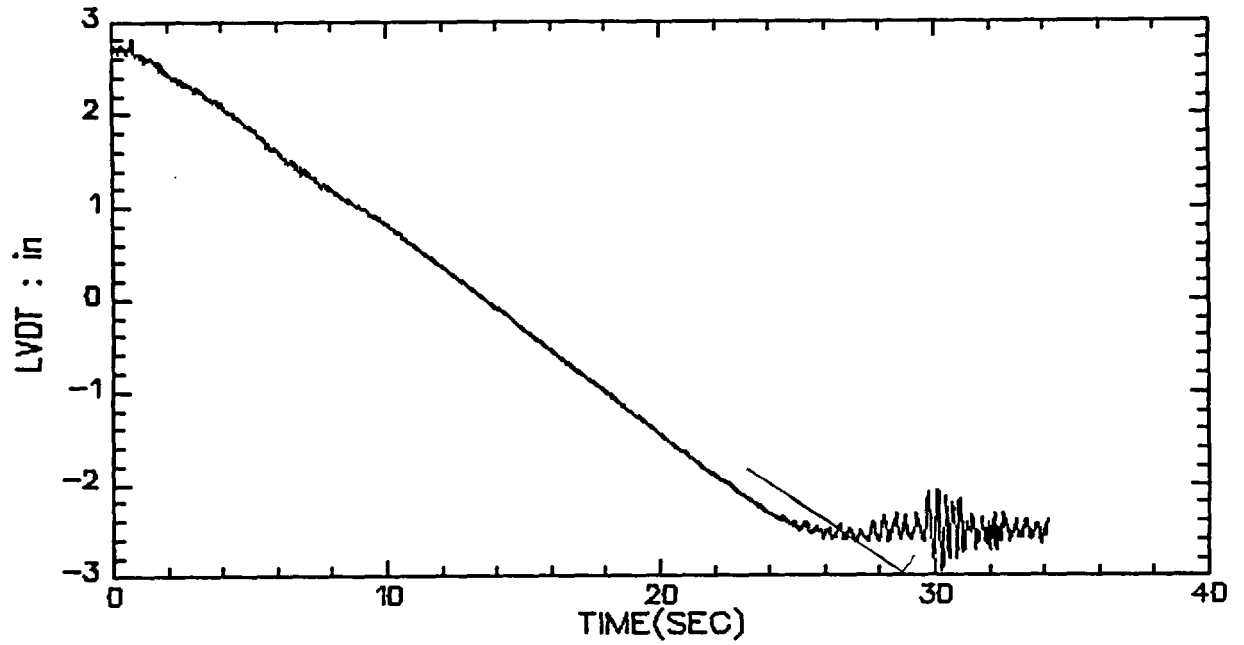

VALVE A, TEST 3, STEP 5

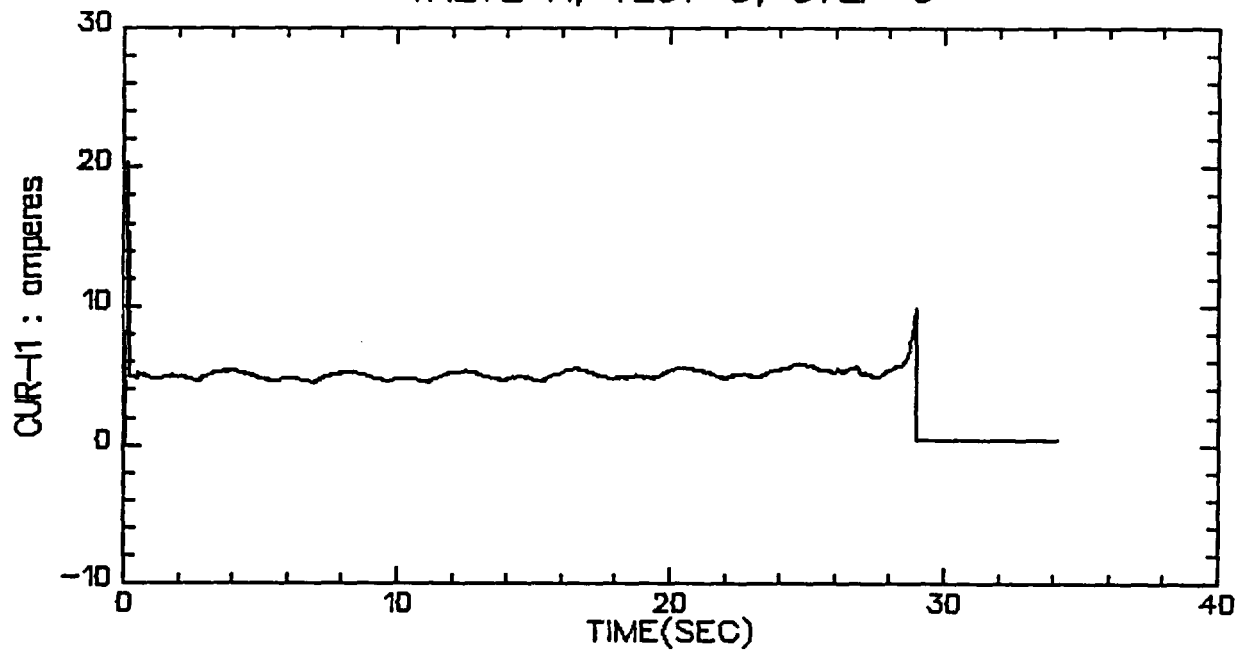

VALVE A, TEST 3, STEP 5

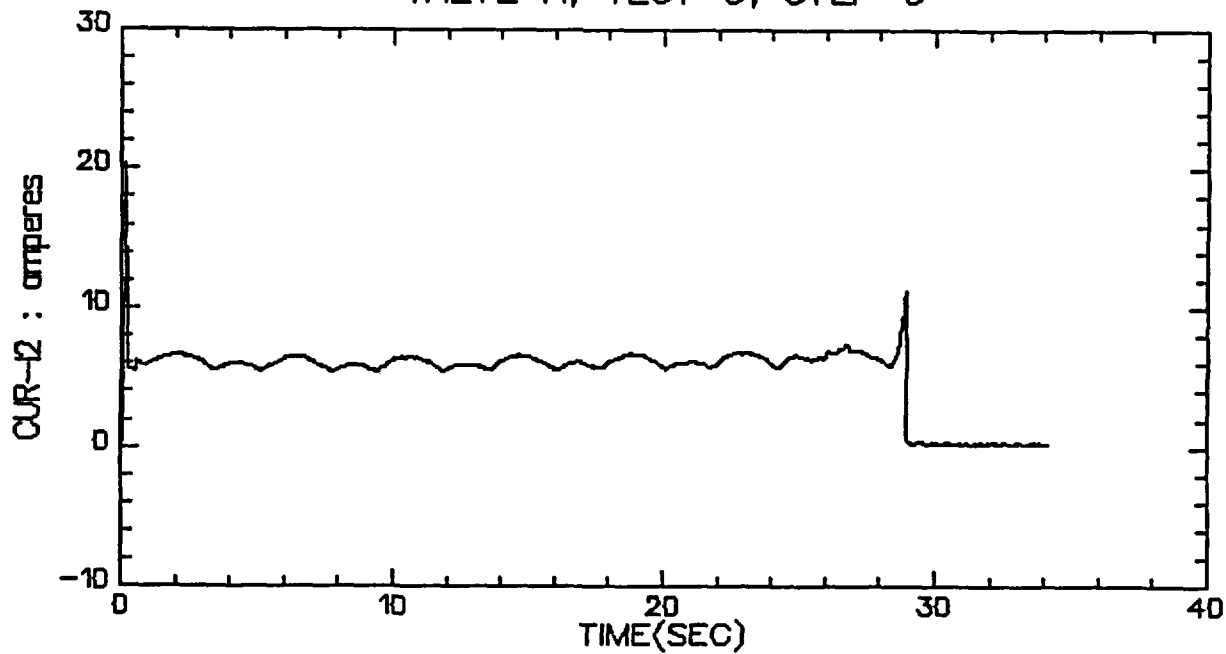

VALVE A, TEST 3, STEP 5

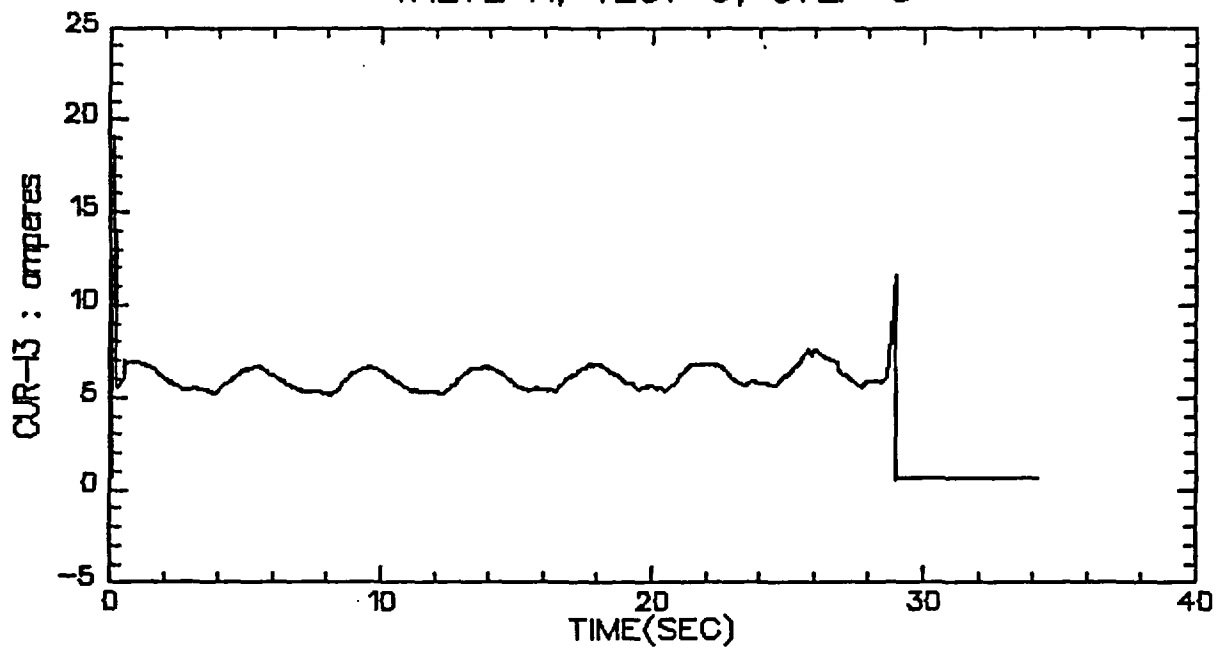

VALVE A, TEST 3, STEP 5

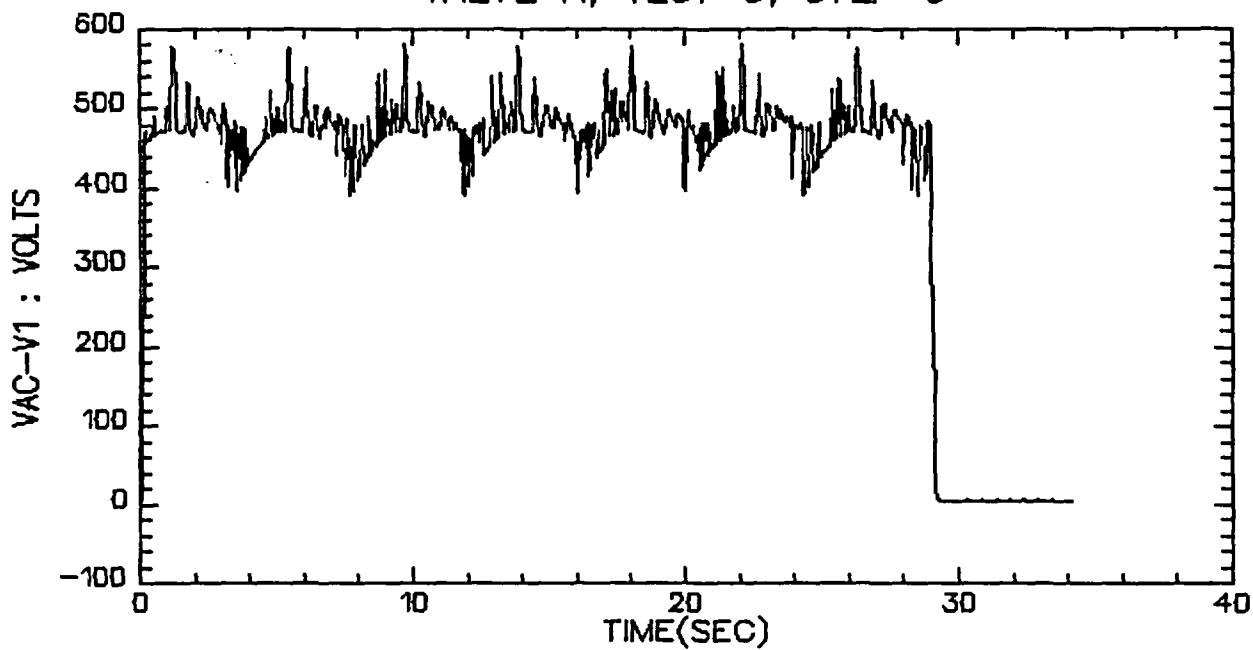

VALVE A, TEST 3, STEP 5

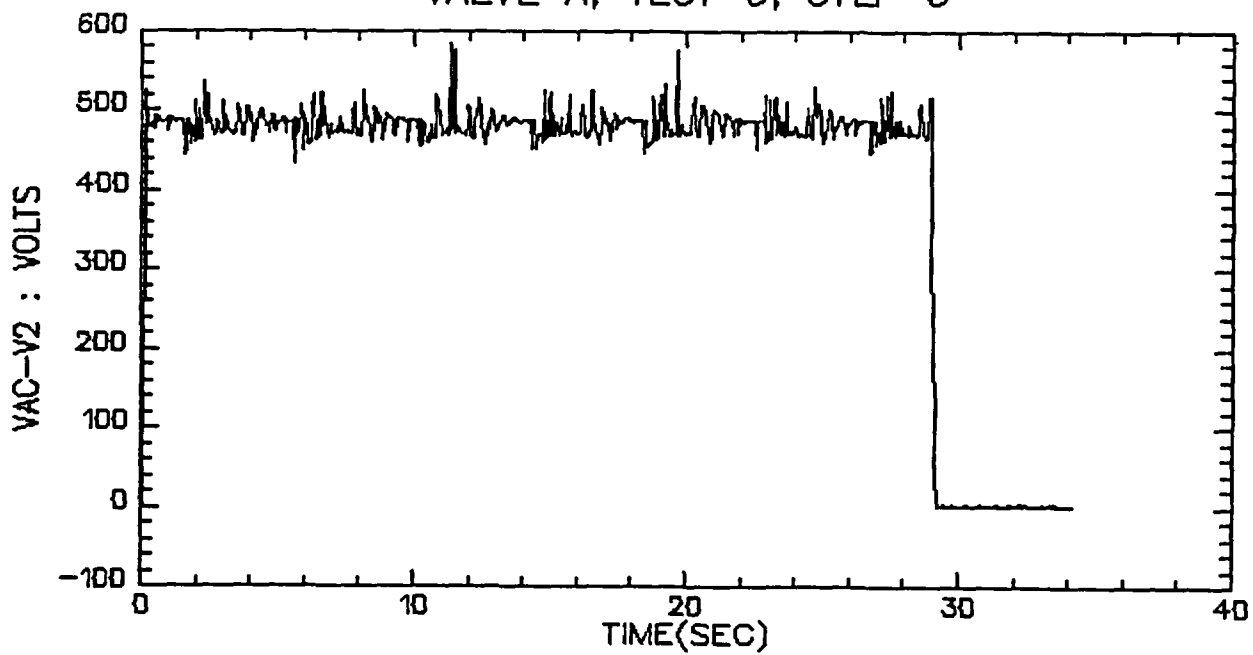

VALVE A, TEST 3, STEP 5

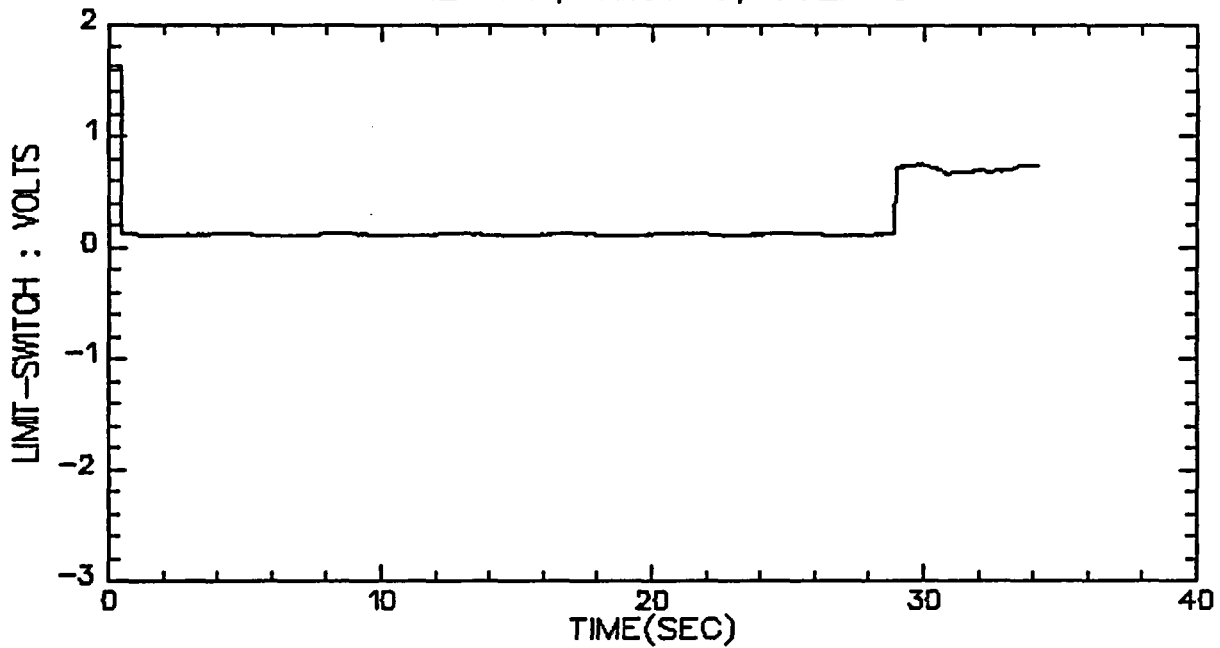

VALVE A, TEST 3, STEP 5

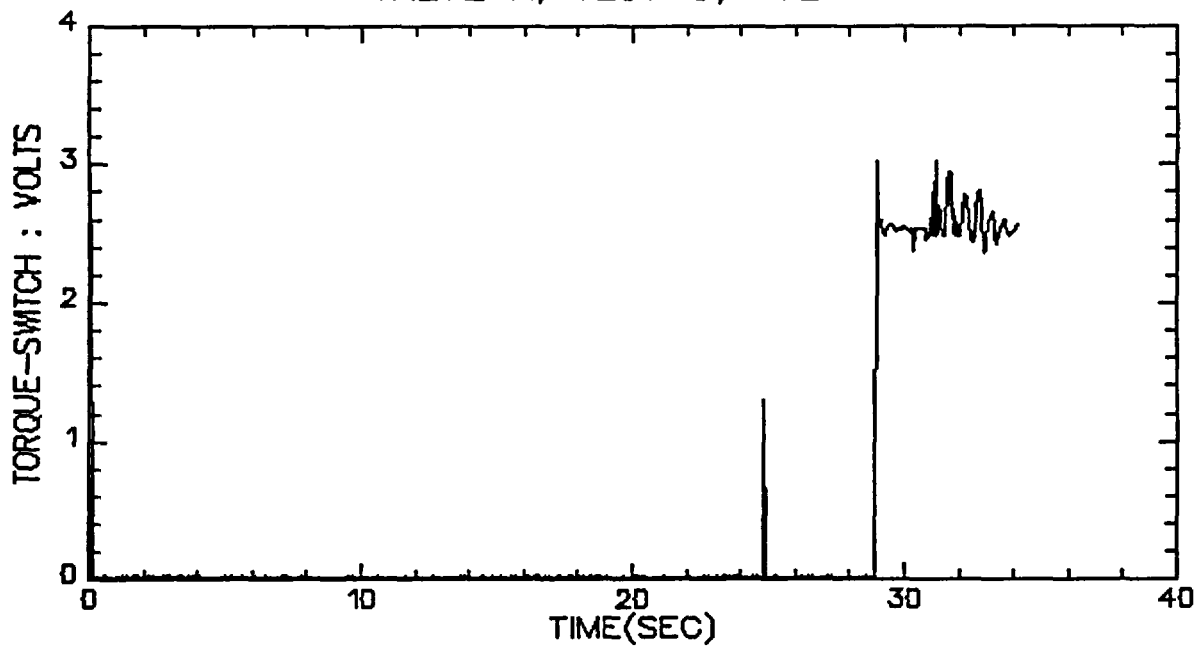

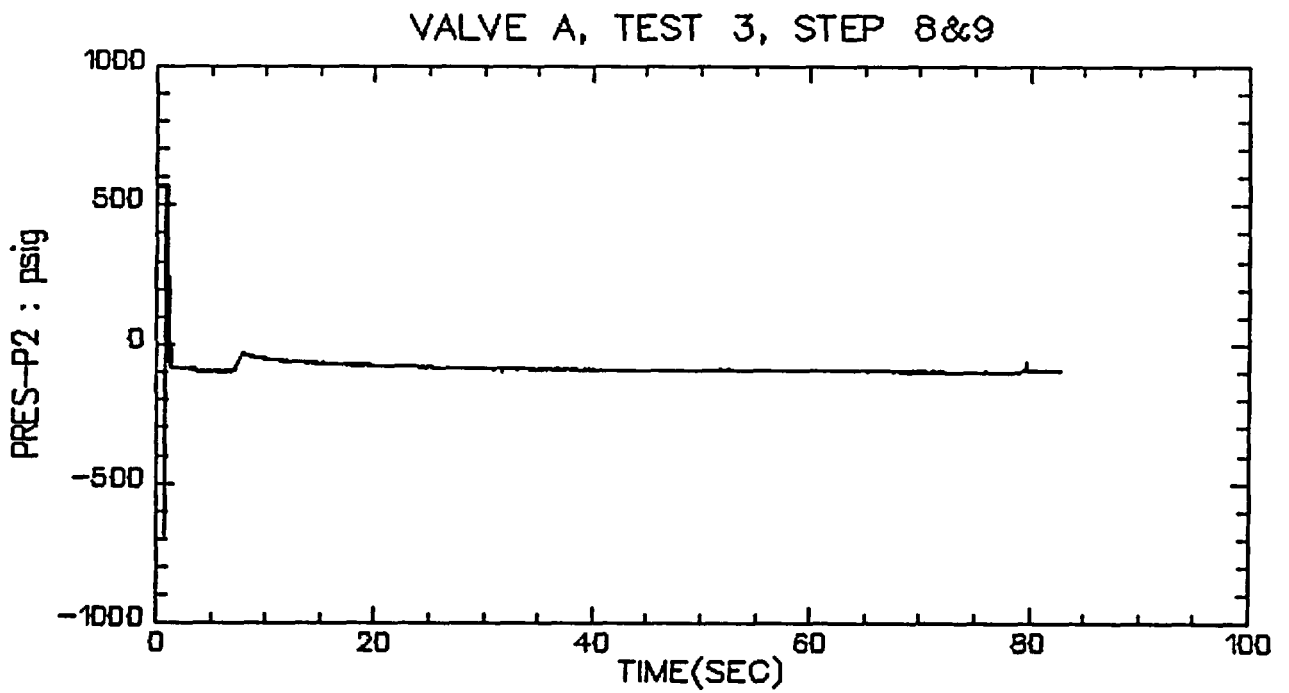
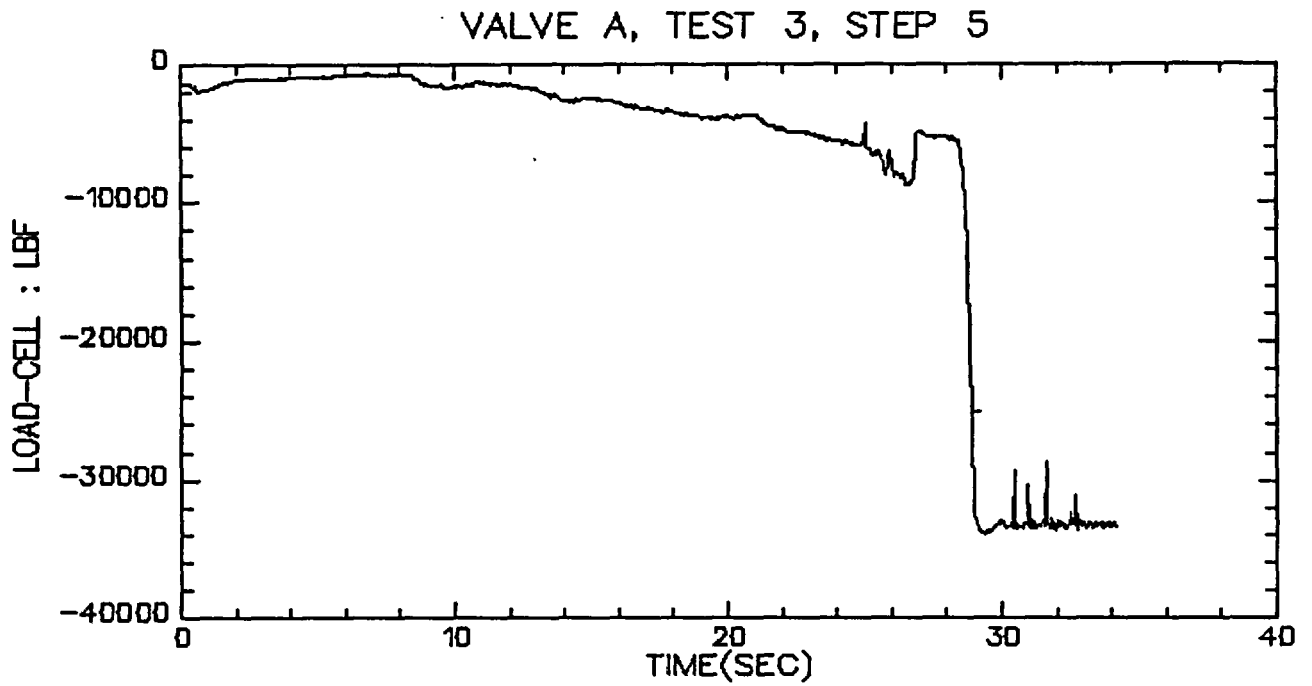

VALVE A, TEST 3, STEP 8&9

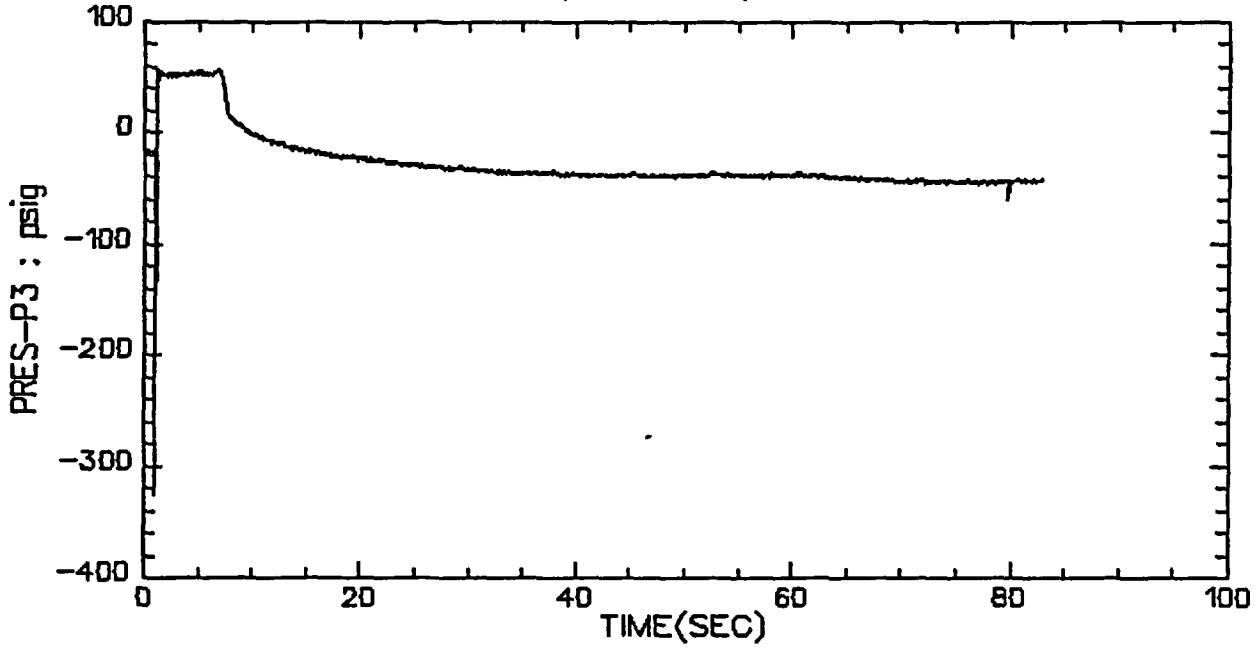

VALVE A, TEST 3, STEP 8&9

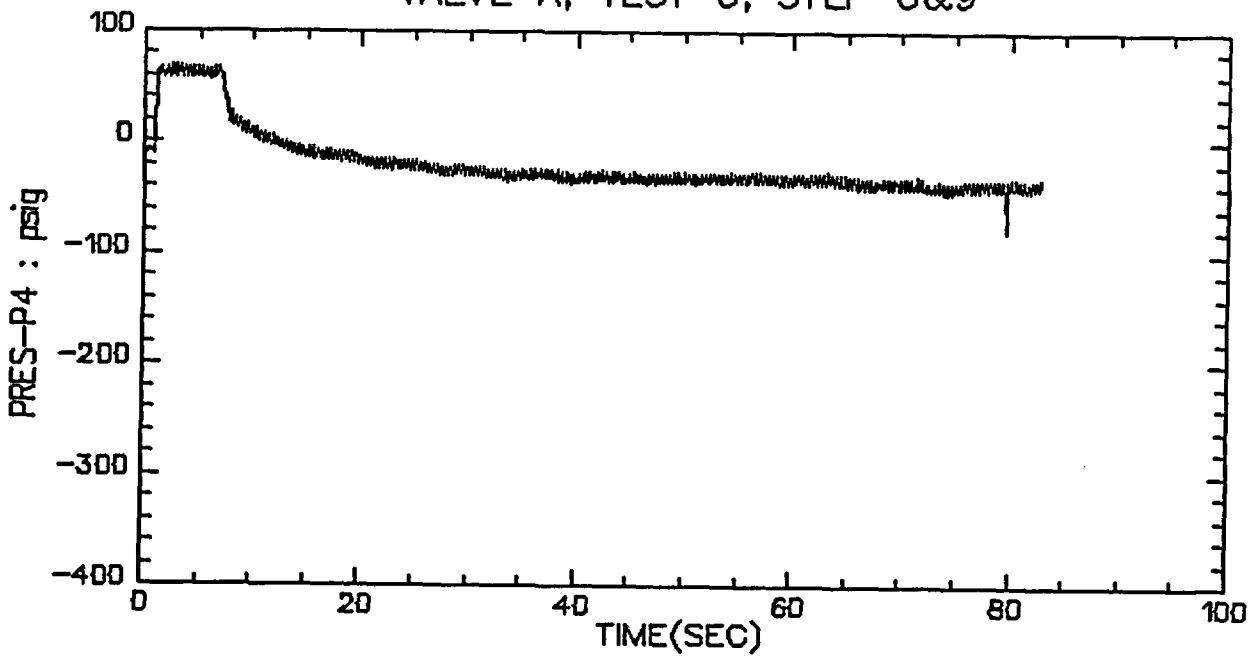

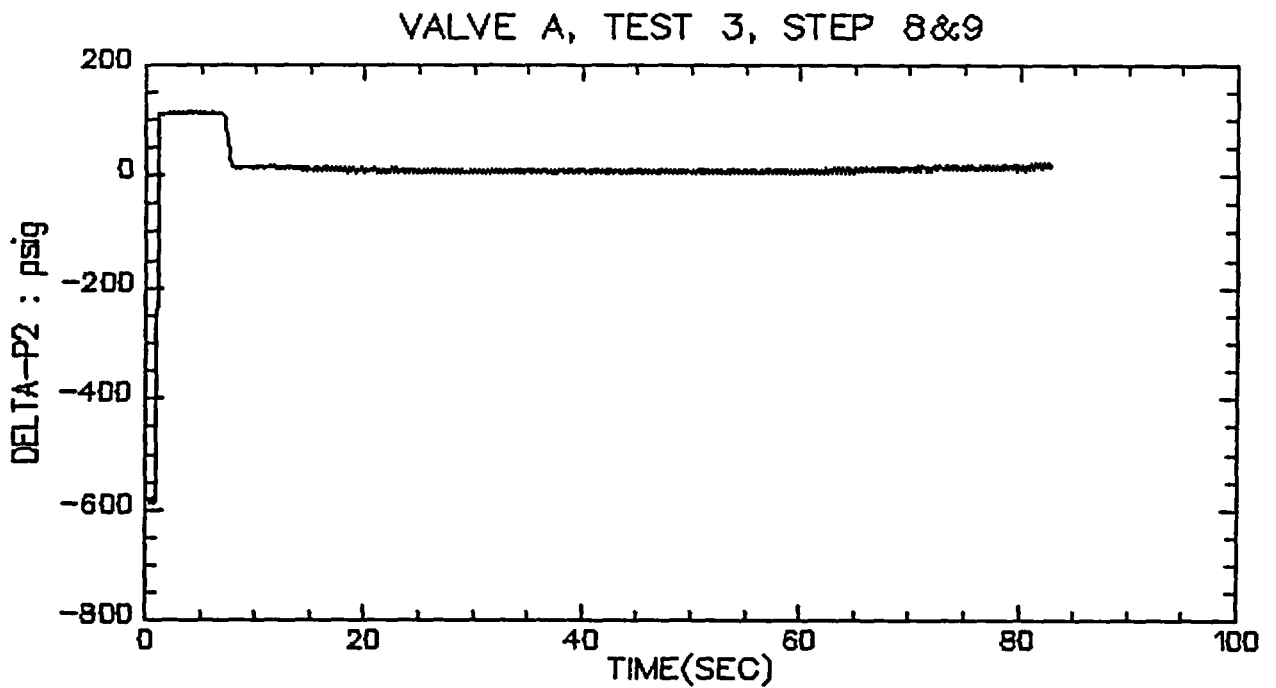
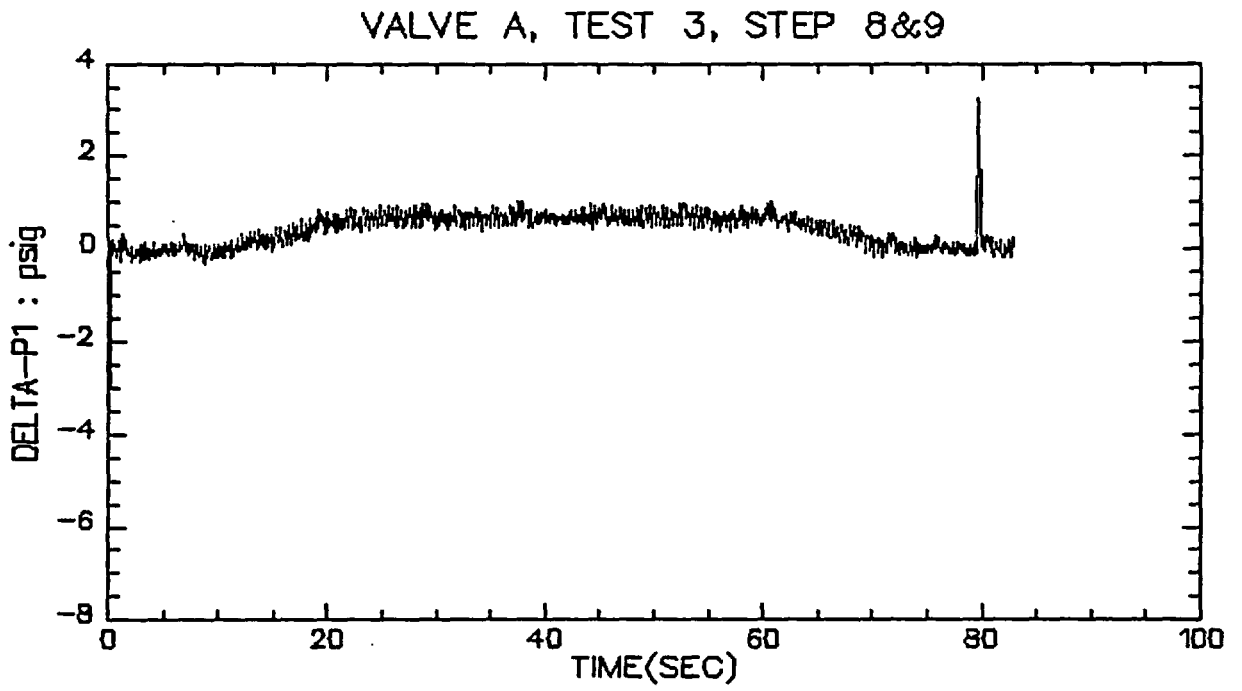

VALVE A, TEST 3, STEP 8&9

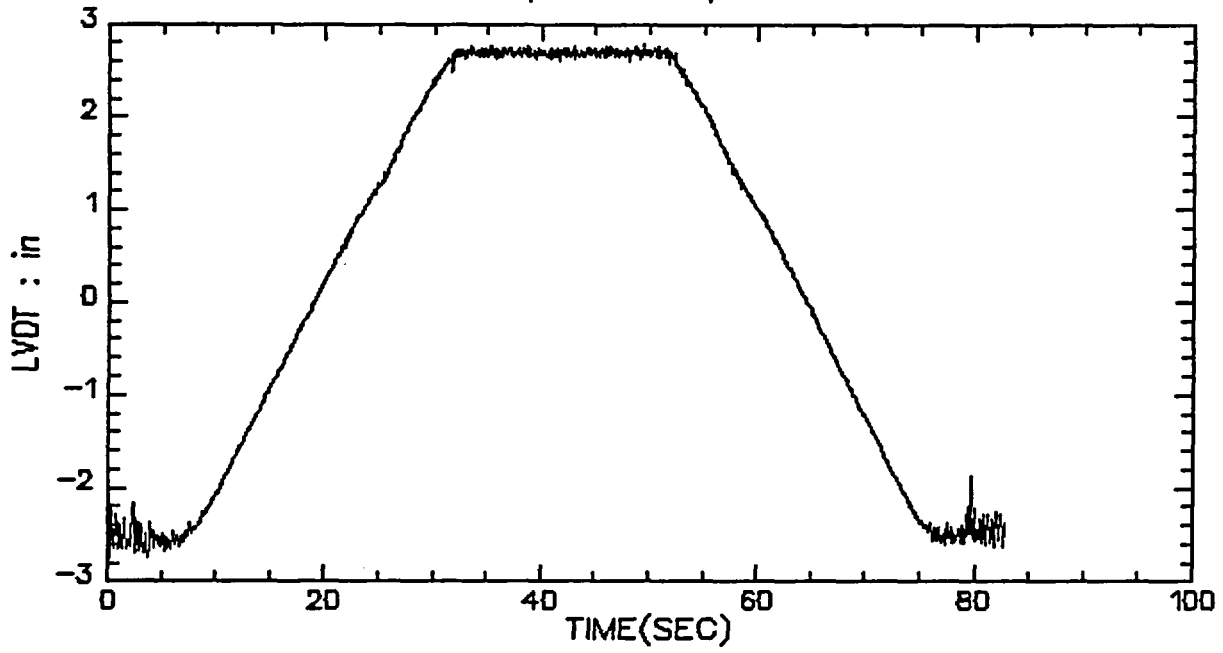

VALVE A, TEST 3, STEP 8&9

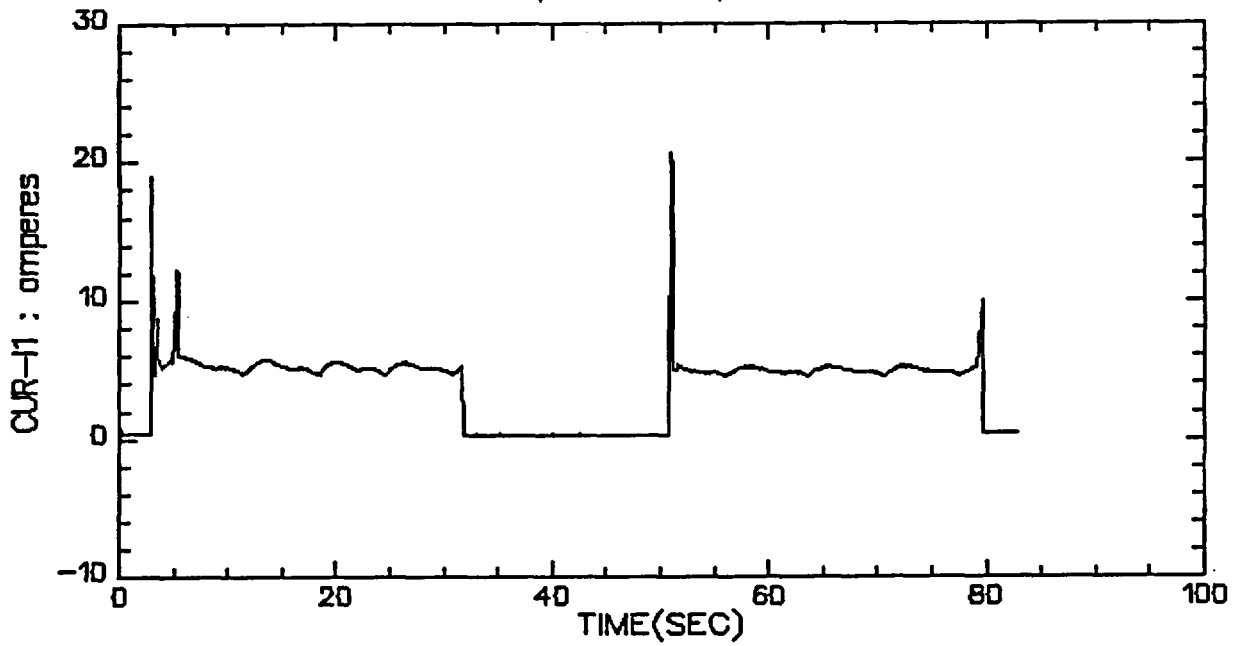

VALVE A, TEST 3, STEP 8&9

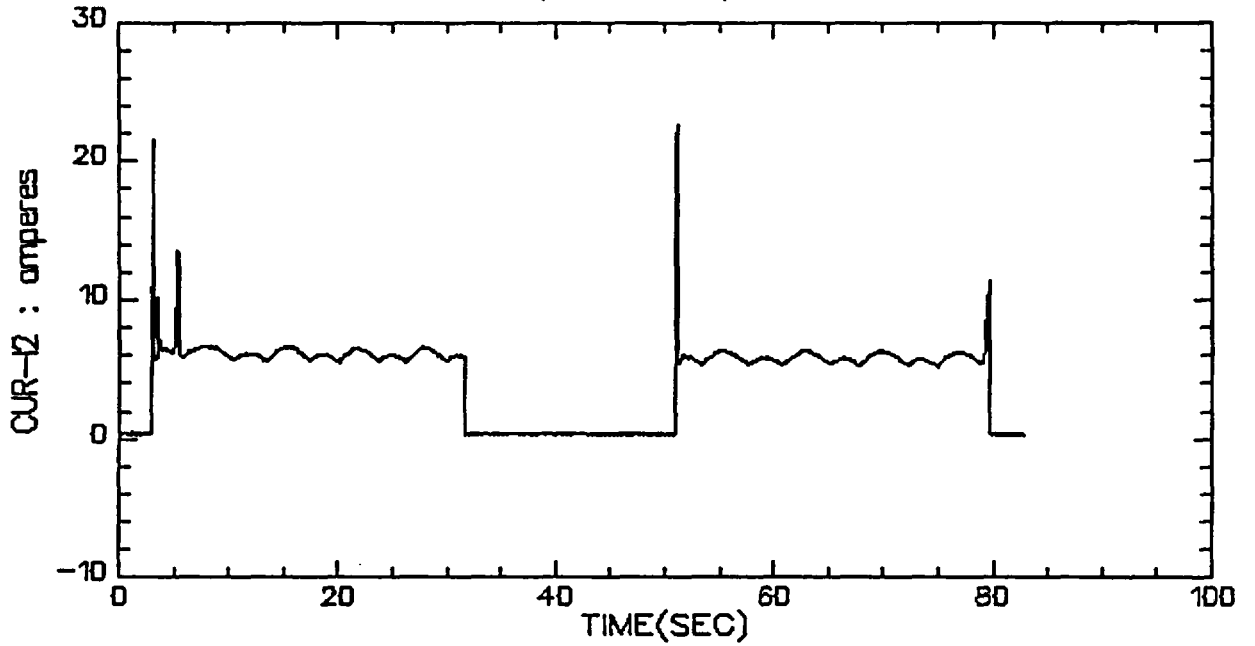

VALVE A, TEST 3, STEP 8&9

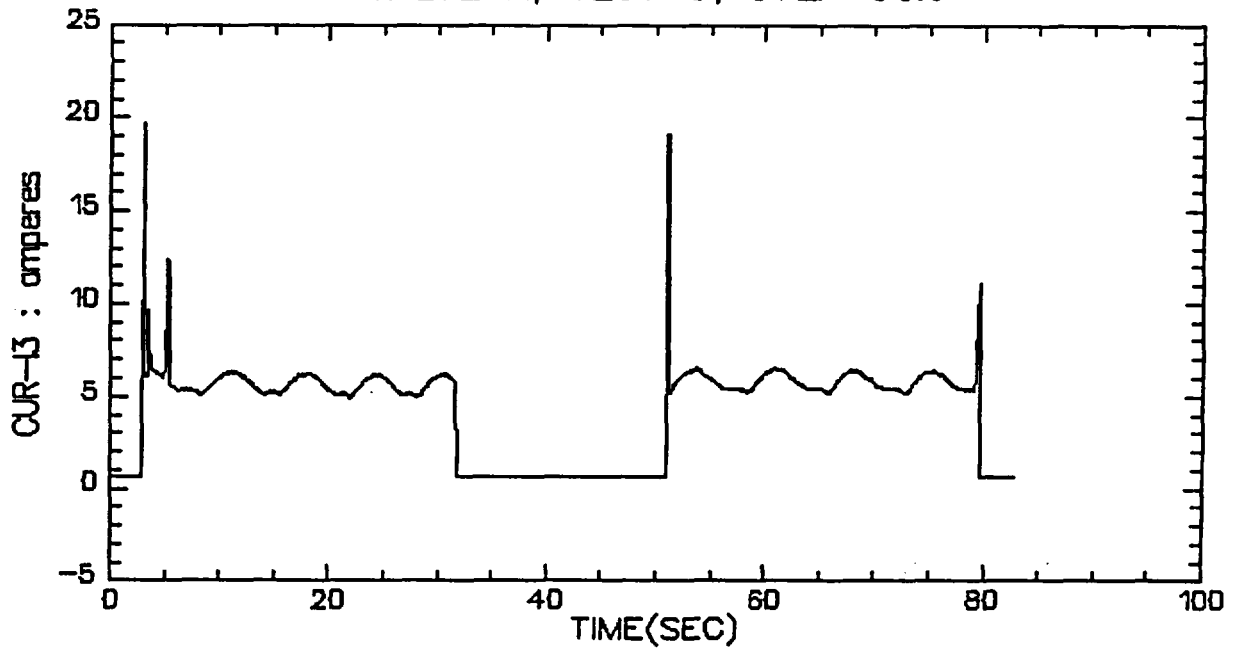

VALVE A, TEST 3, STEP 8&9

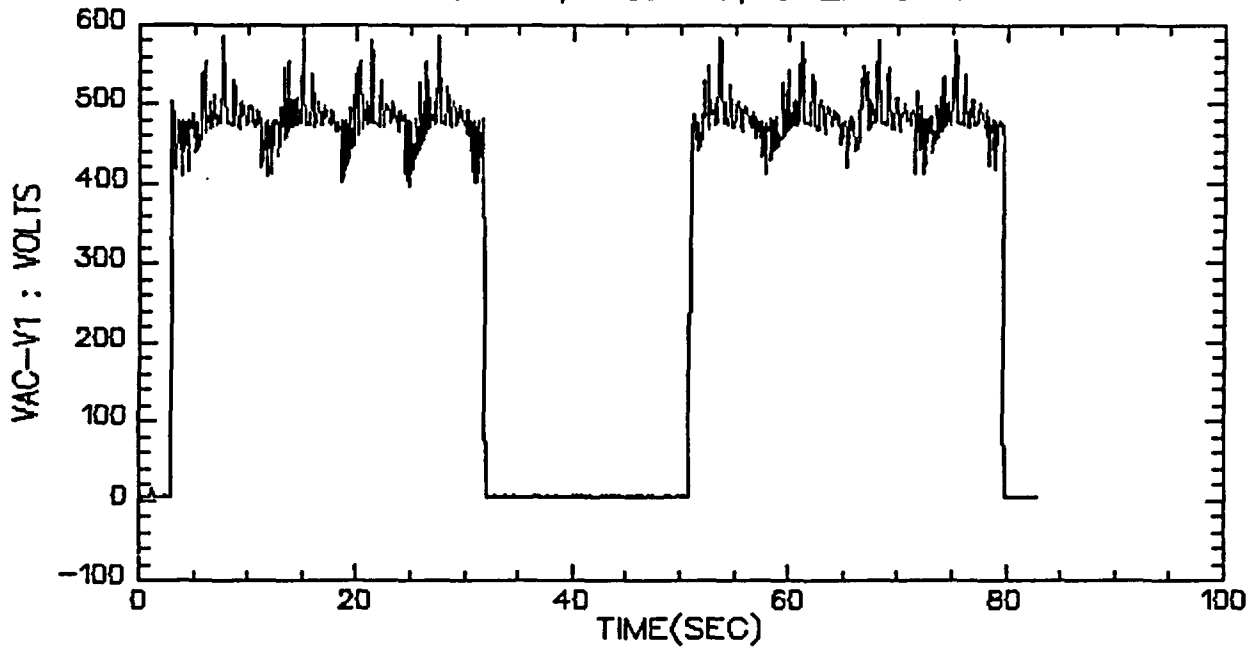

VALVE A, TEST 3, STEP 8&9

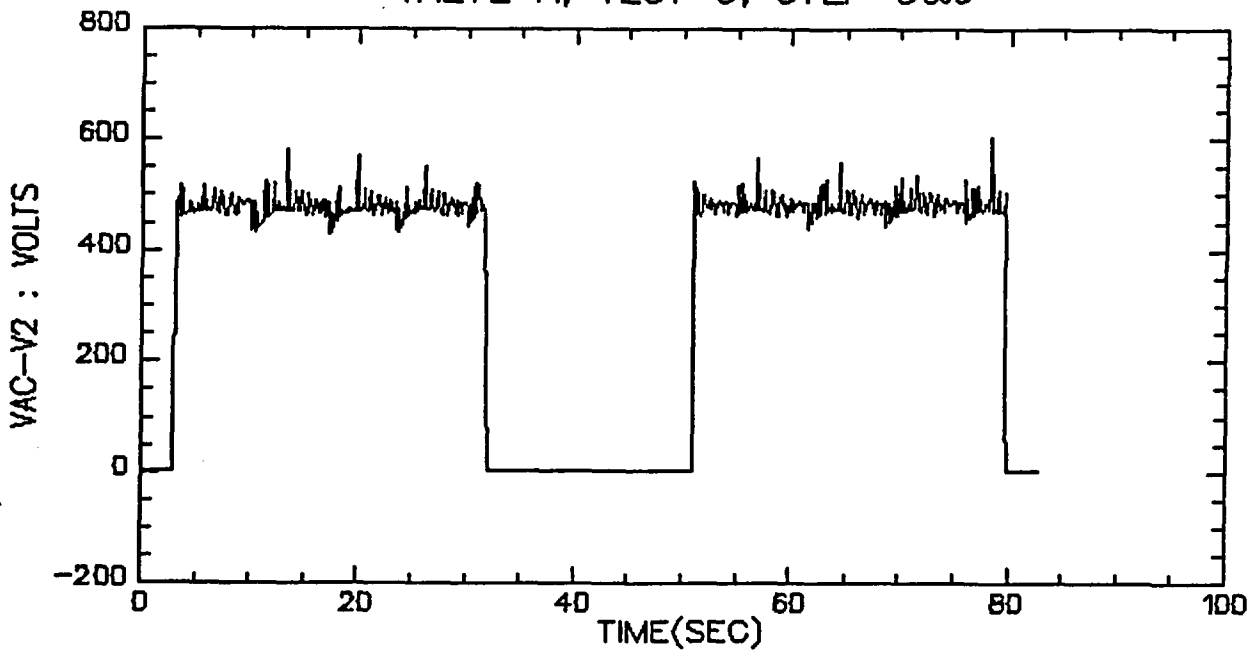

VALVE A, TEST 3, STEP 8&9

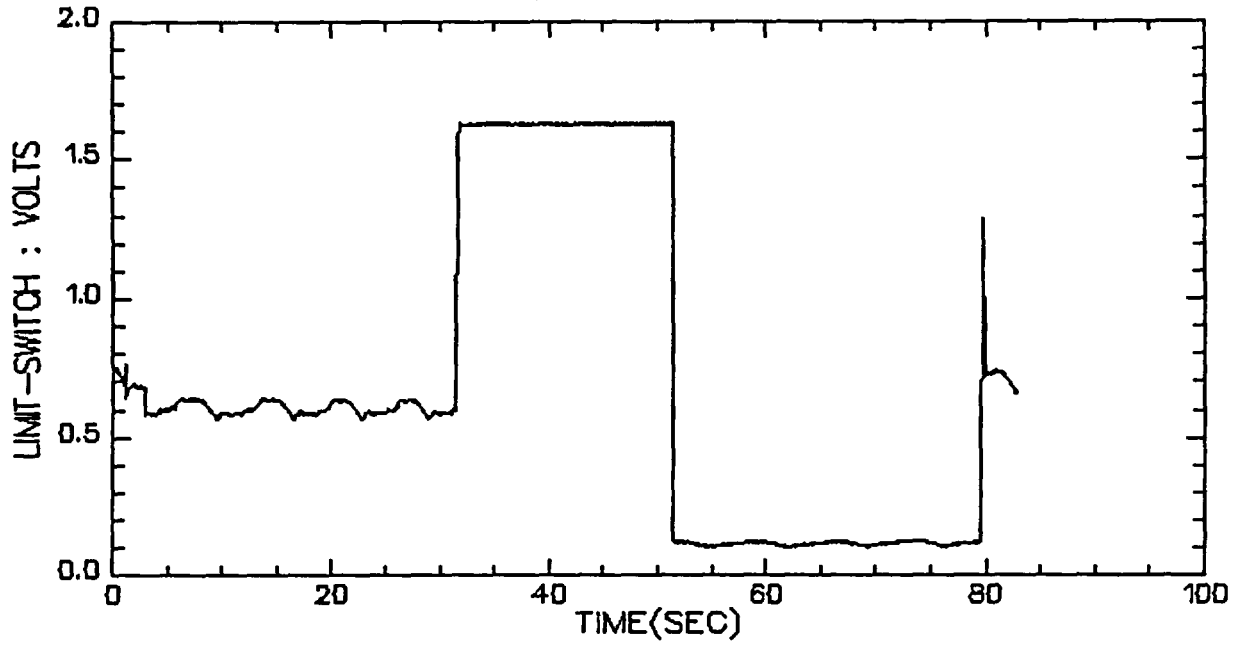

VALVE A, TEST 3, STEP 8&9

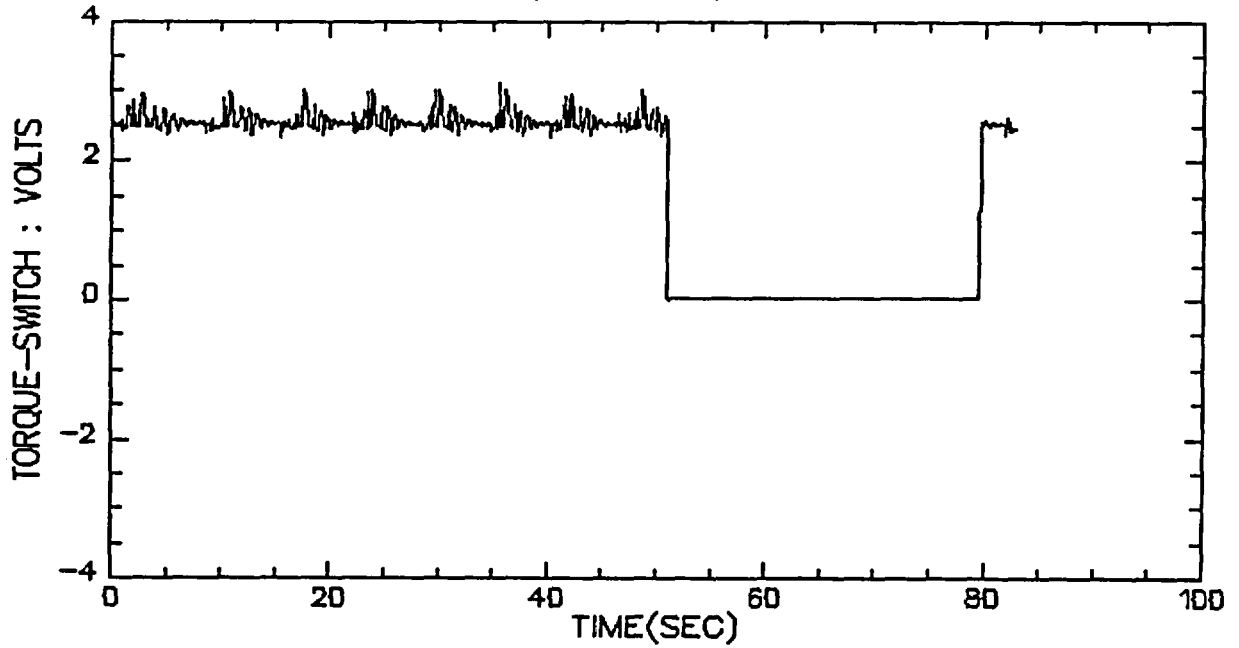

VALVE A, TEST 4, STEP 1

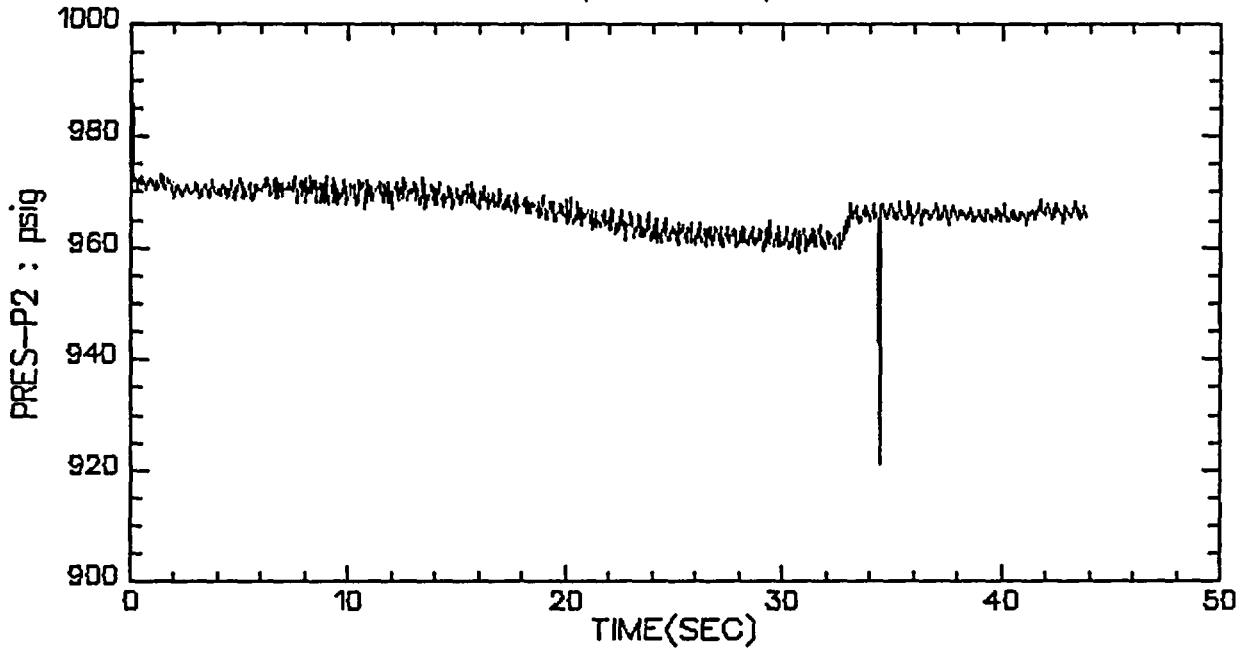

VALVE A, TEST 4, STEP 1

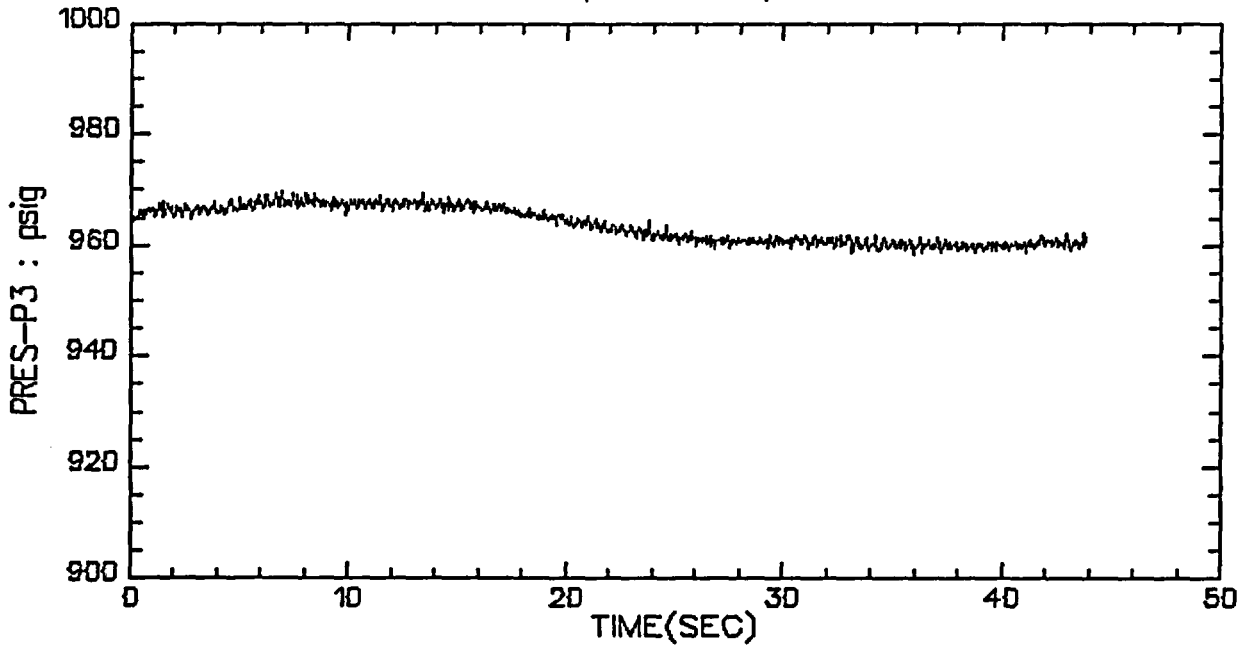

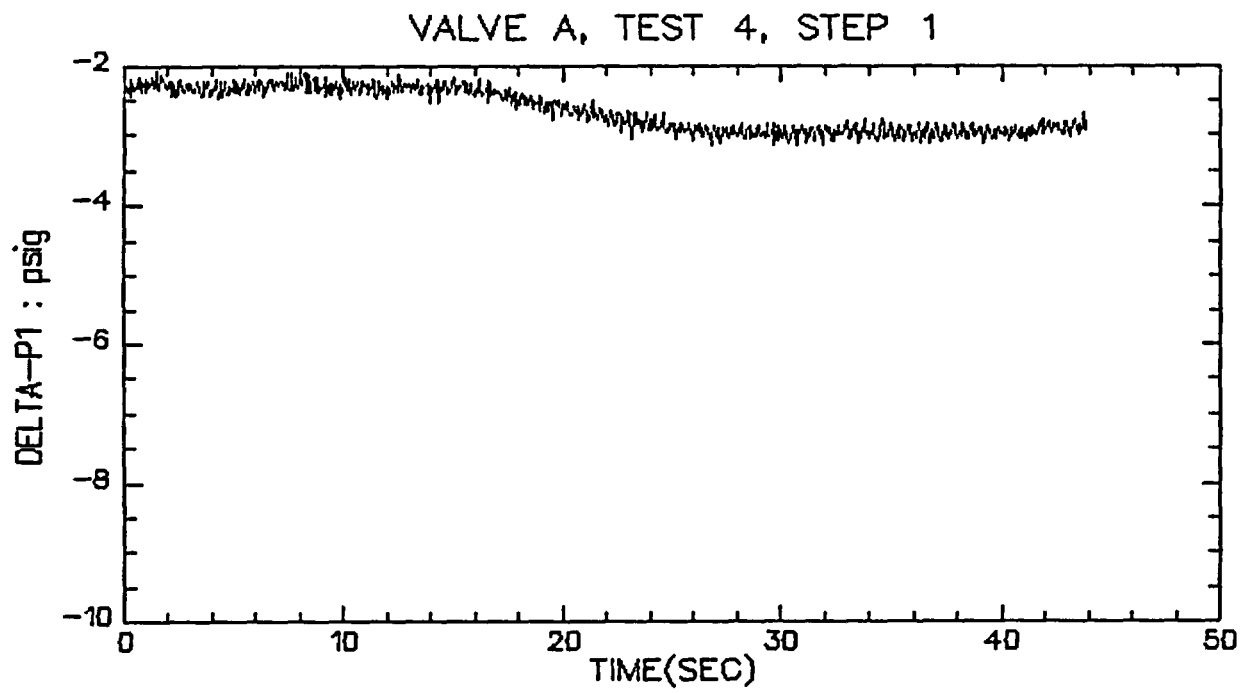
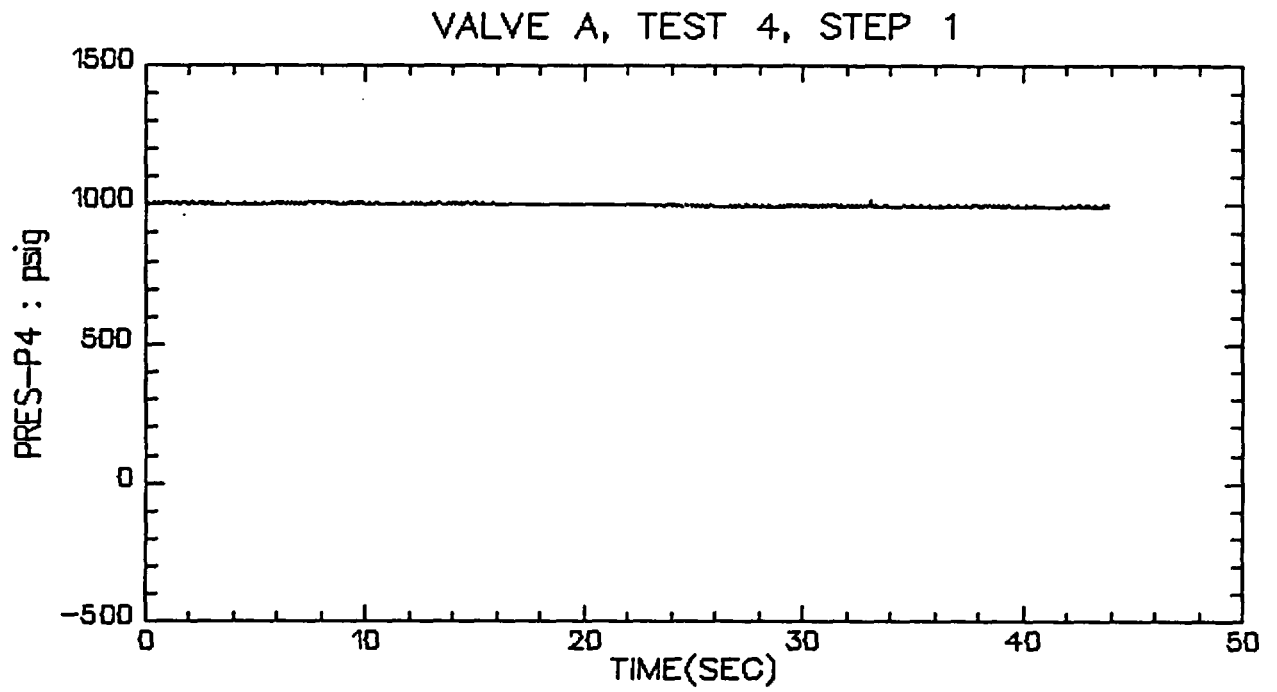

VALVE A, TEST 4, STEP 1

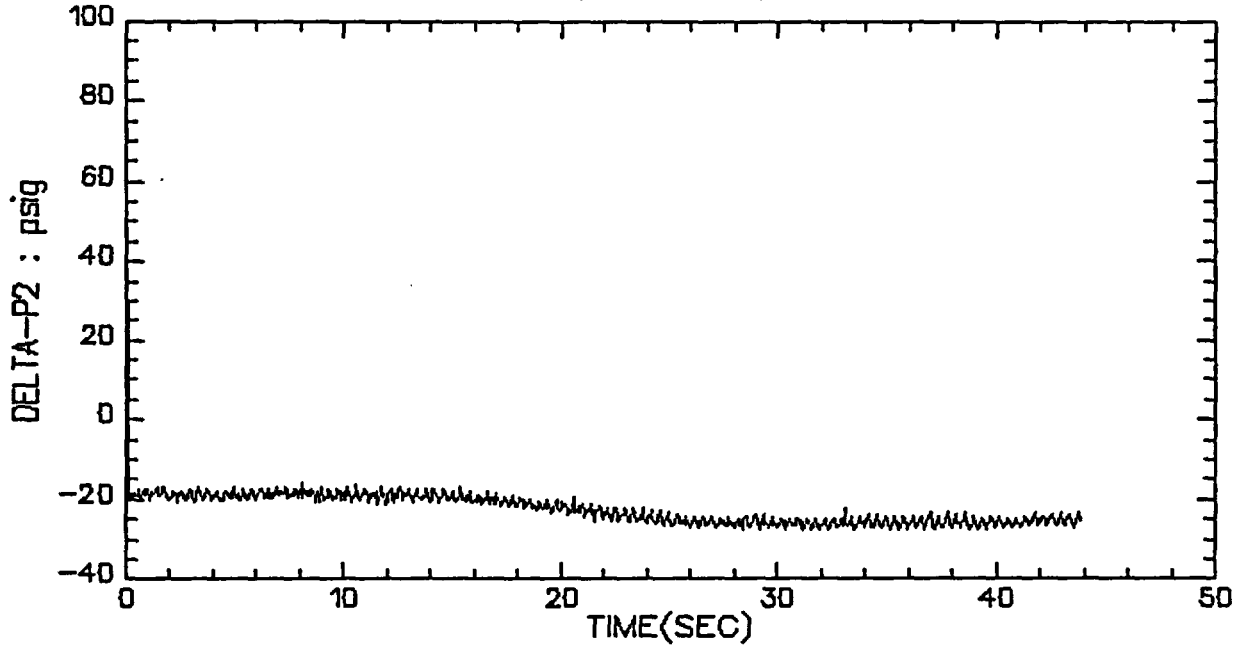

VALVE A, TEST 4, STEP 1

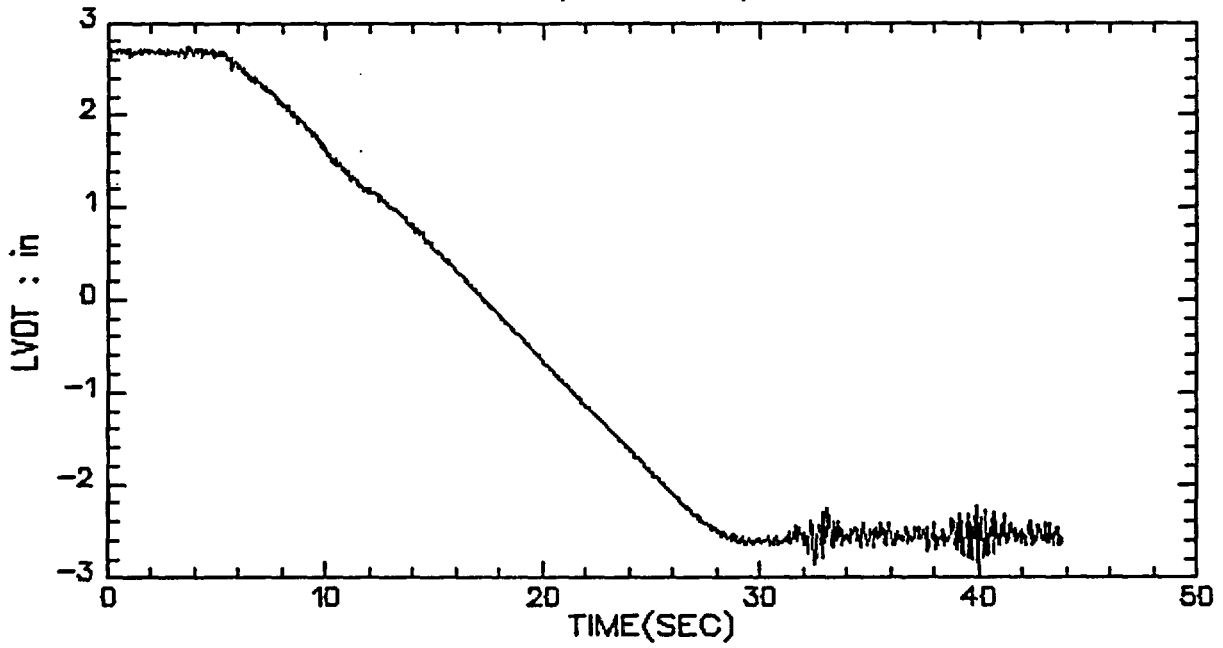

VALVE A, TEST 4, STEP 1

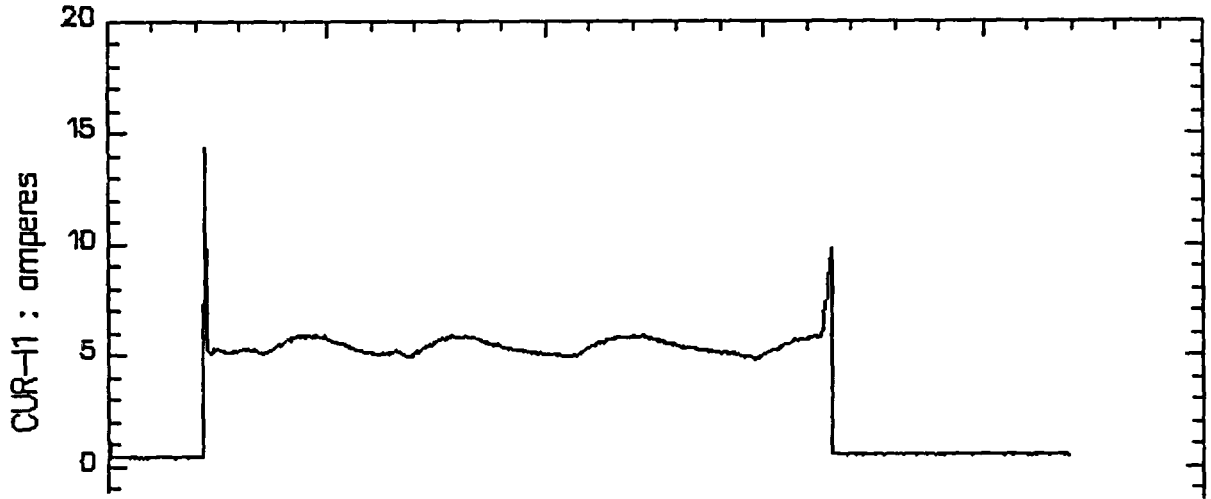

VALVE A, TEST 4, STEP 1

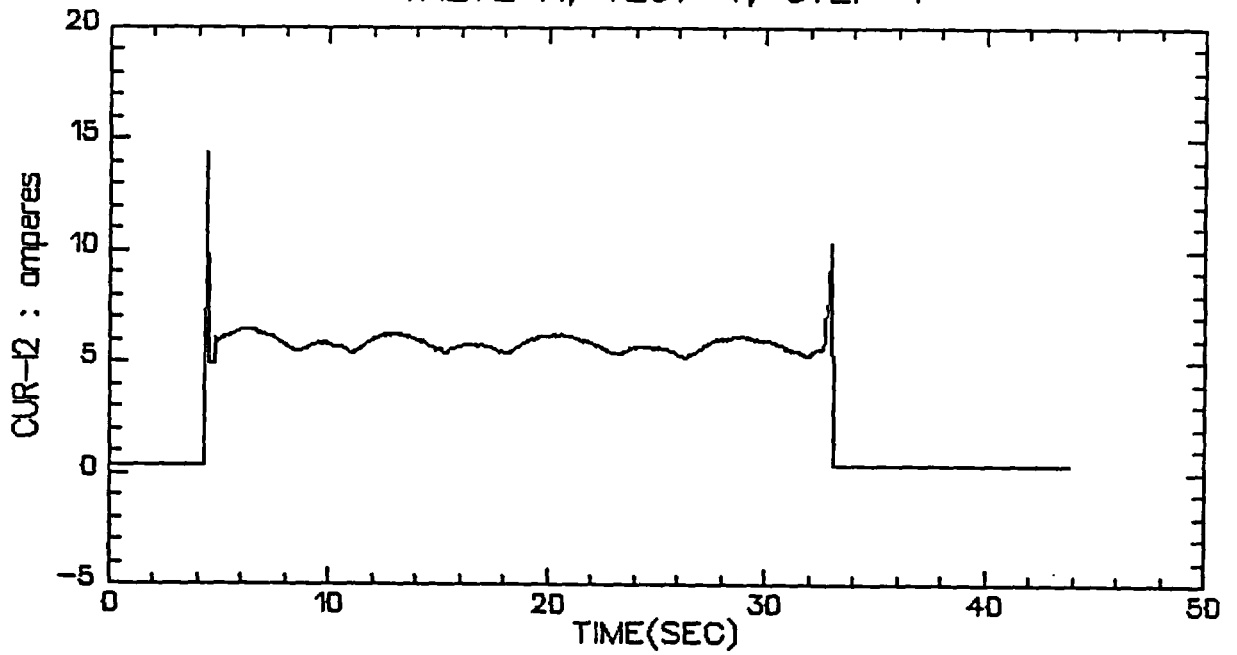

VALVE A, TEST 4, STEP 1

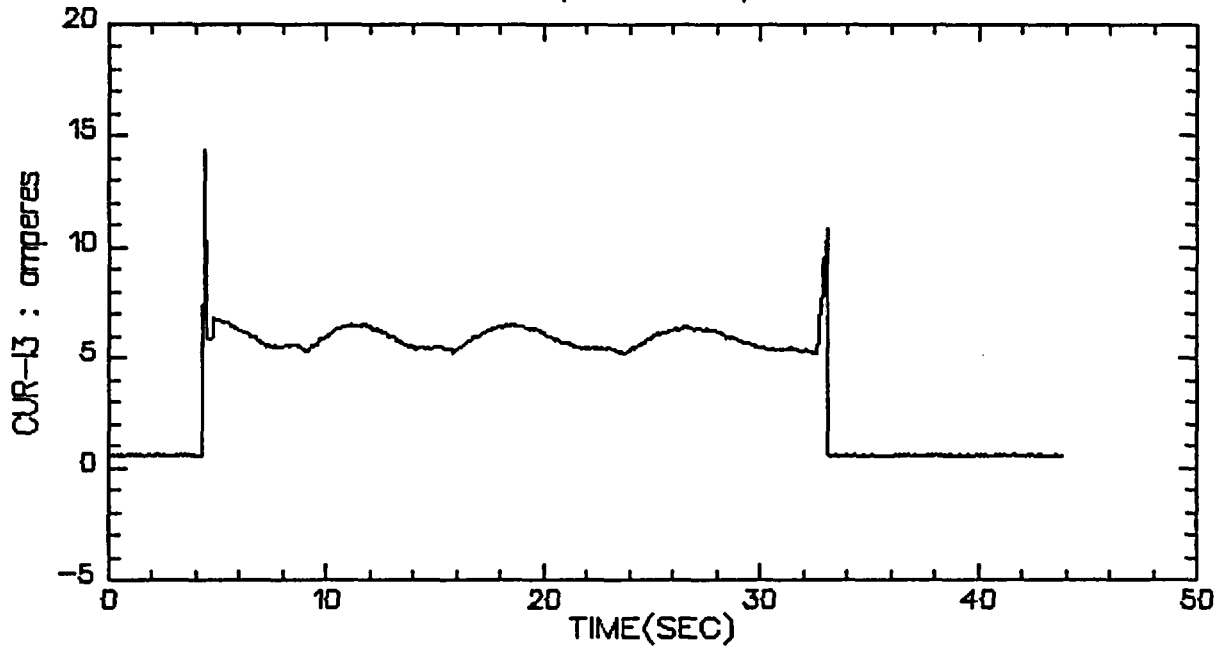

VALVE A, TEST 4, STEP 1

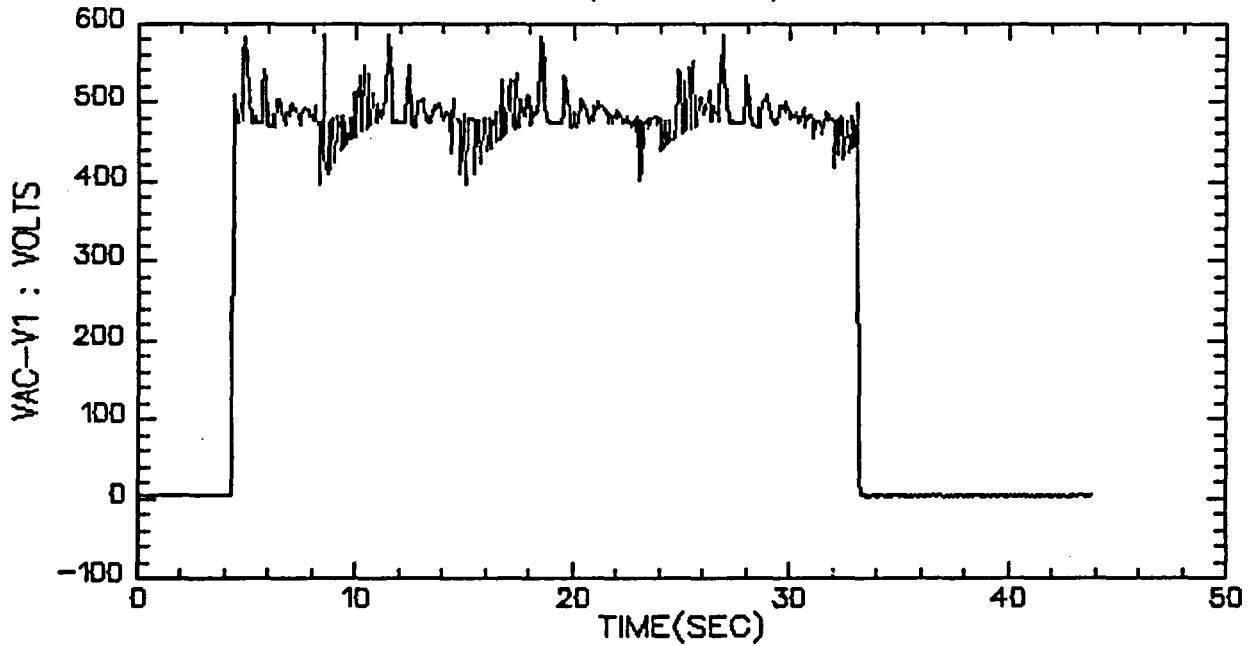

VALVE A, TEST 4, STEP 1

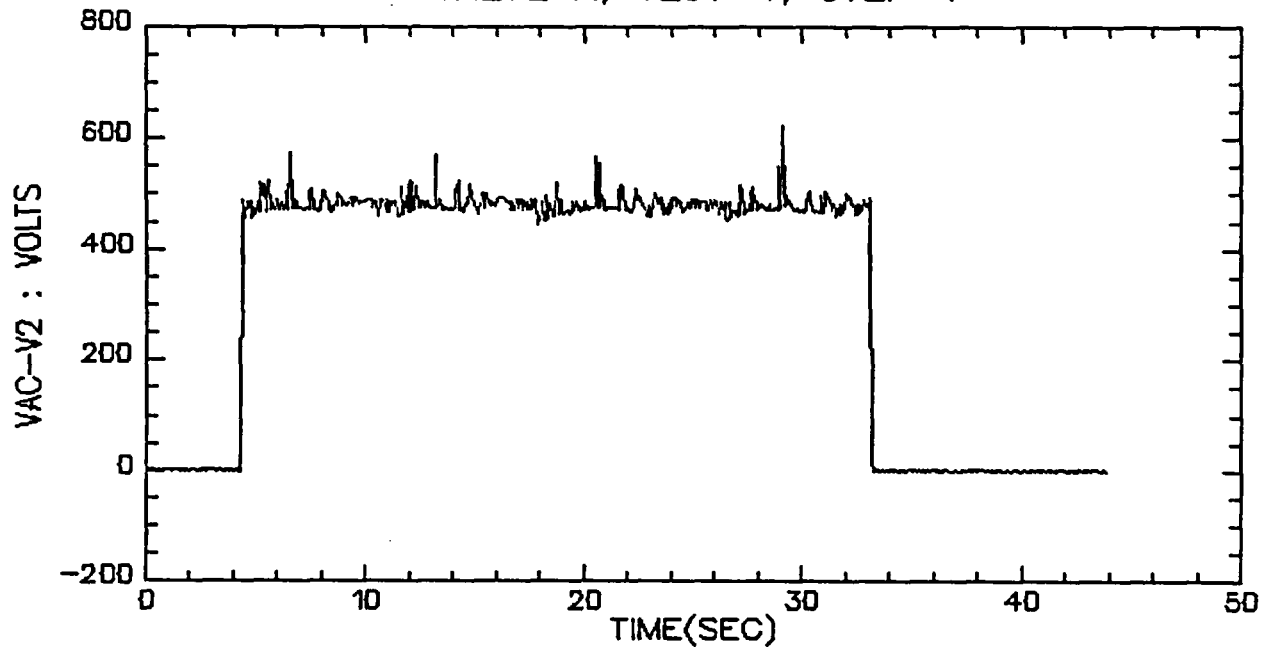

VALVE A, TEST 4, STEP 1

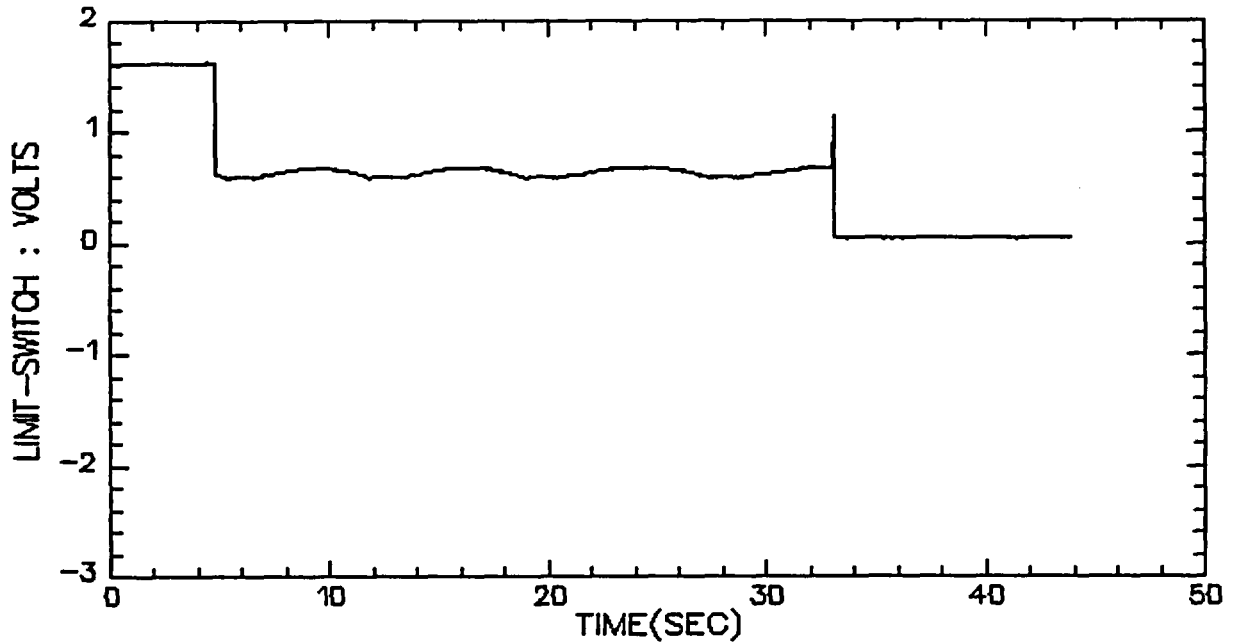

VALVE A, TEST 4, STEP 1

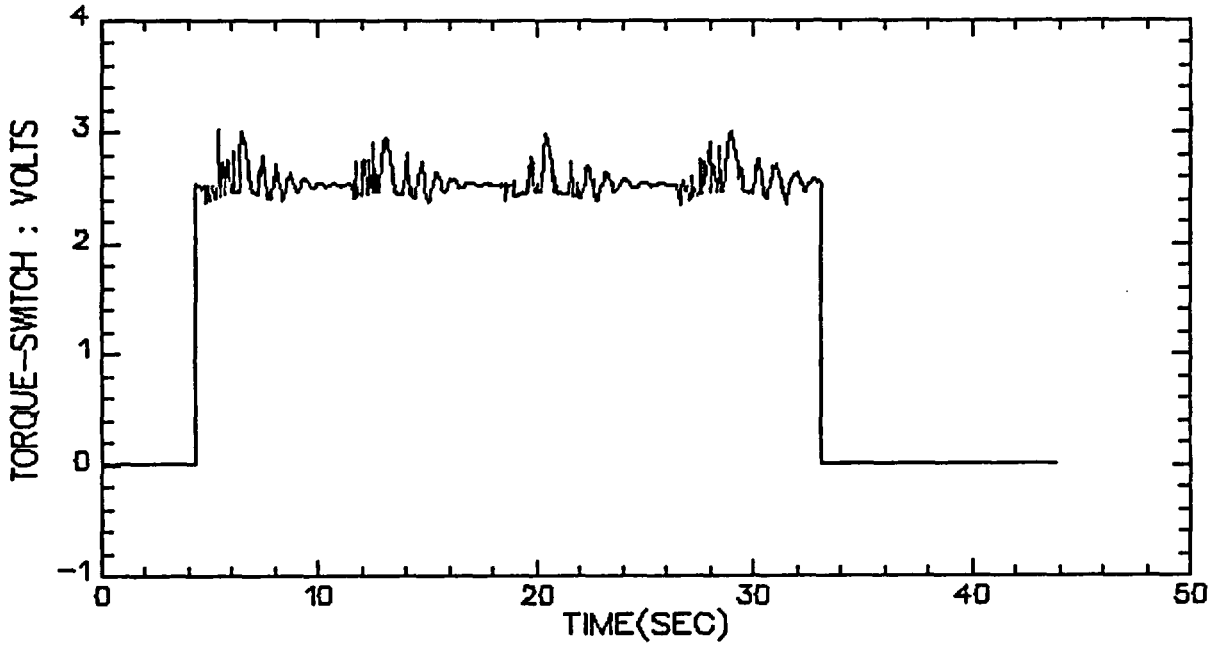

VALVE A, TEST 4, STEP 1

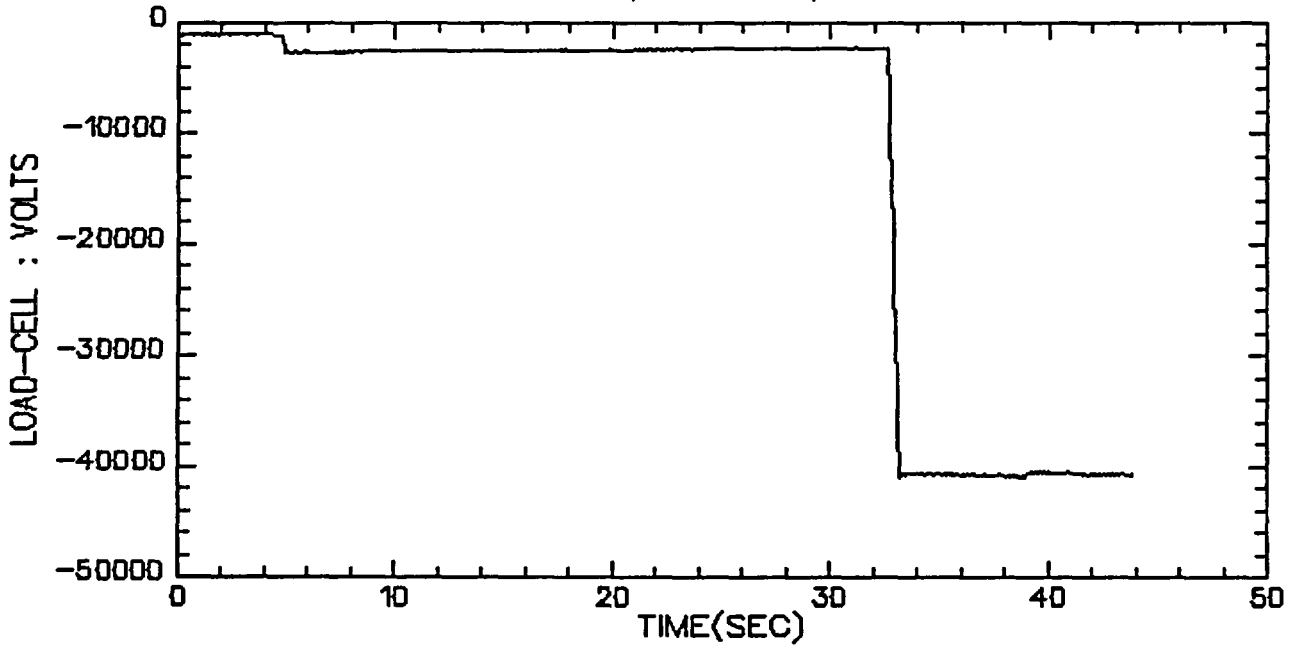

VALVE A, TEST 4, STEP 2

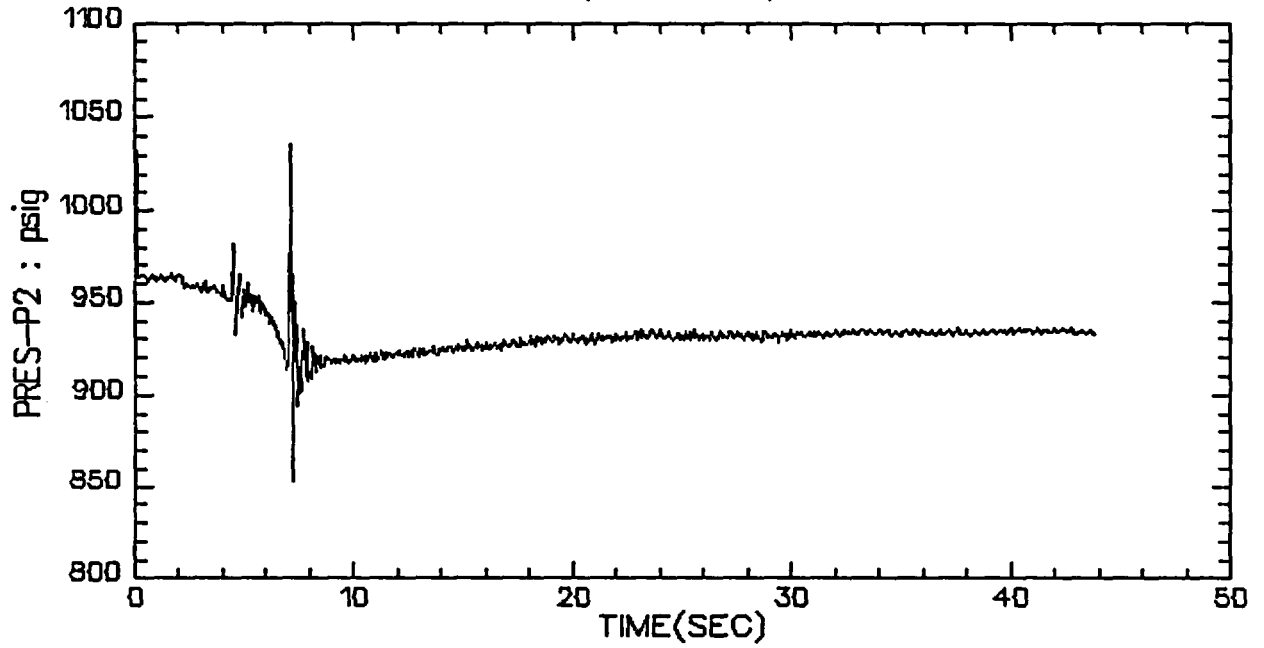

VALVE A, TEST 4, STEP 2

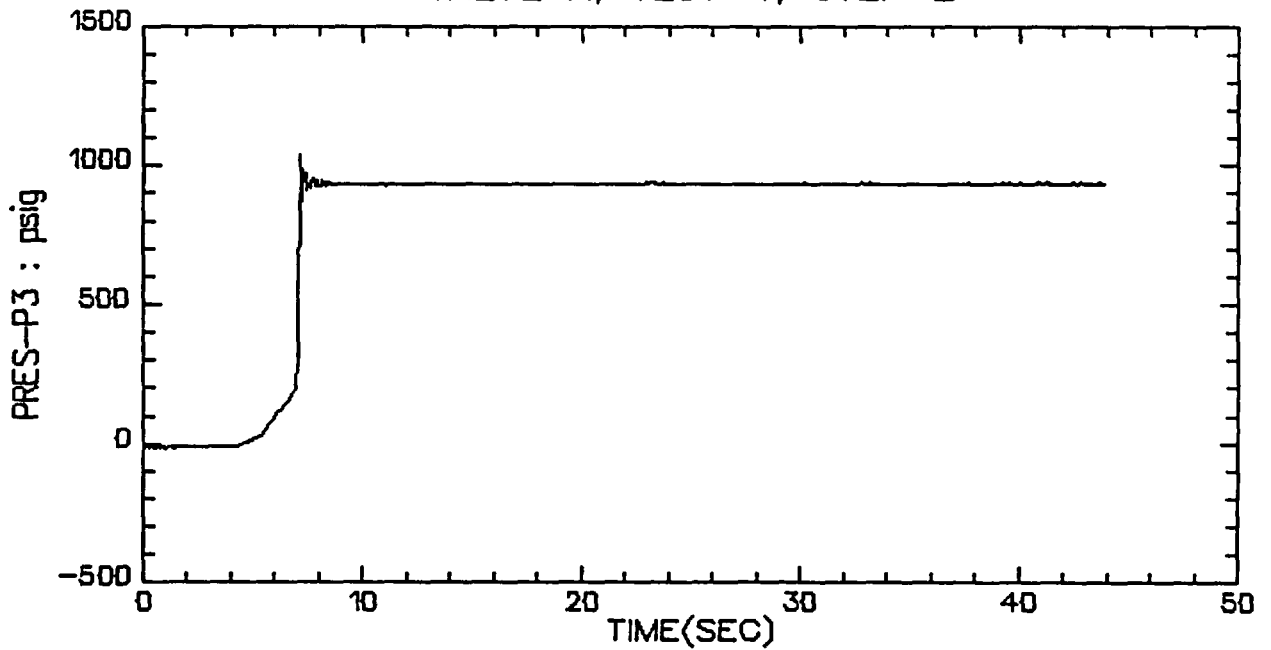

VALVE A, TEST 4, STEP 2

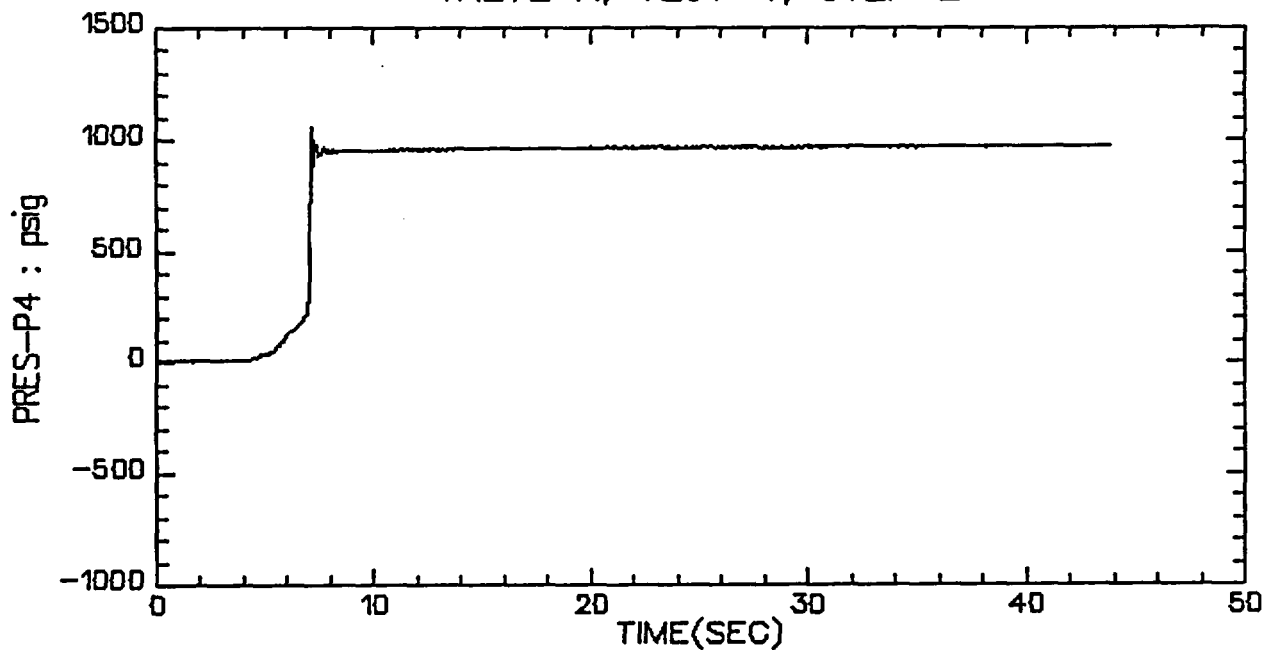

VALVE A, TEST 4, STEP 2

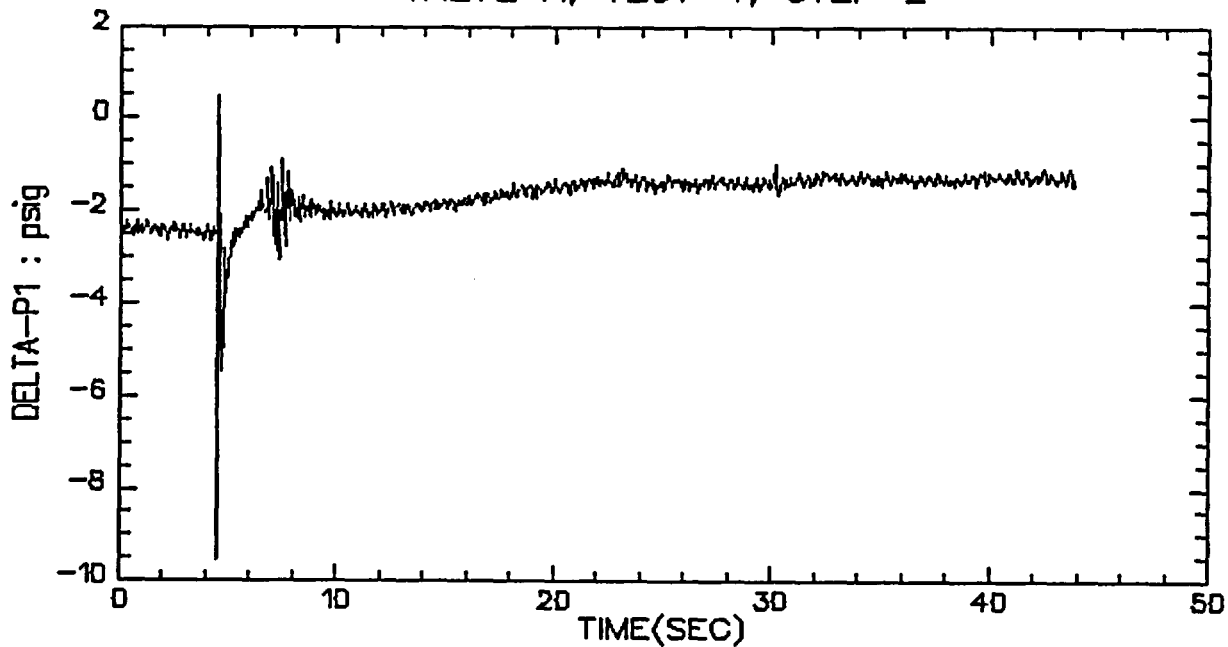

VALVE A, TEST 4, STEP 2

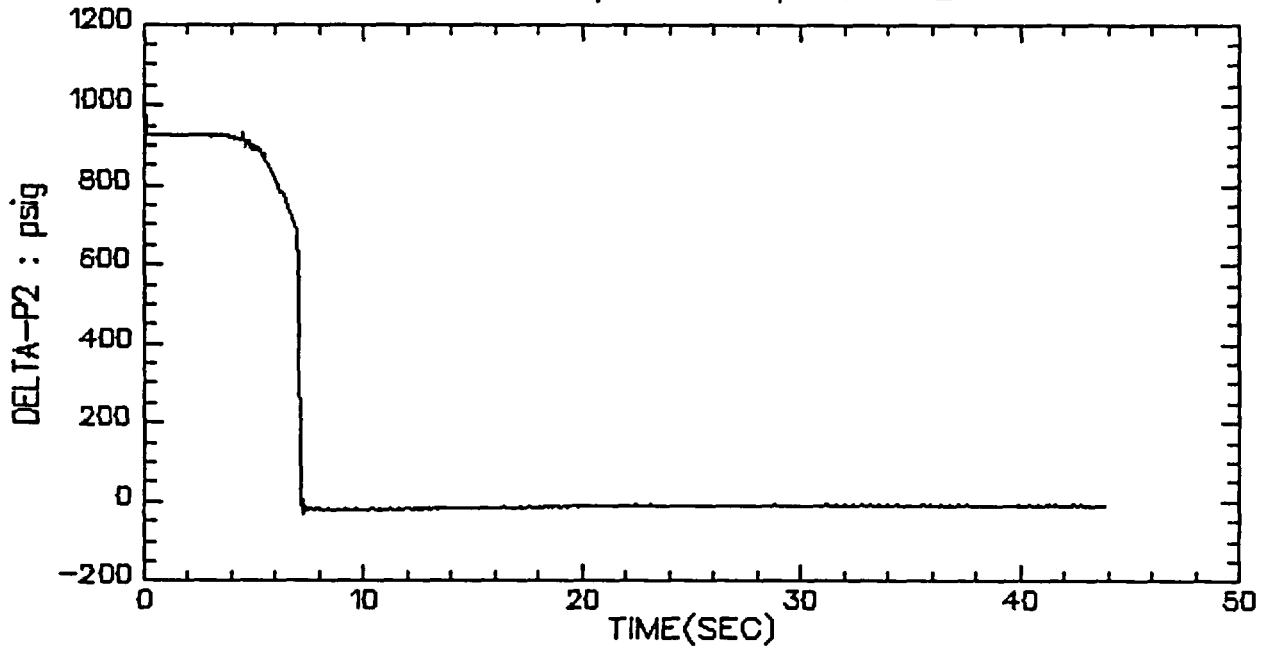

VALVE A, TEST 4, STEP 2

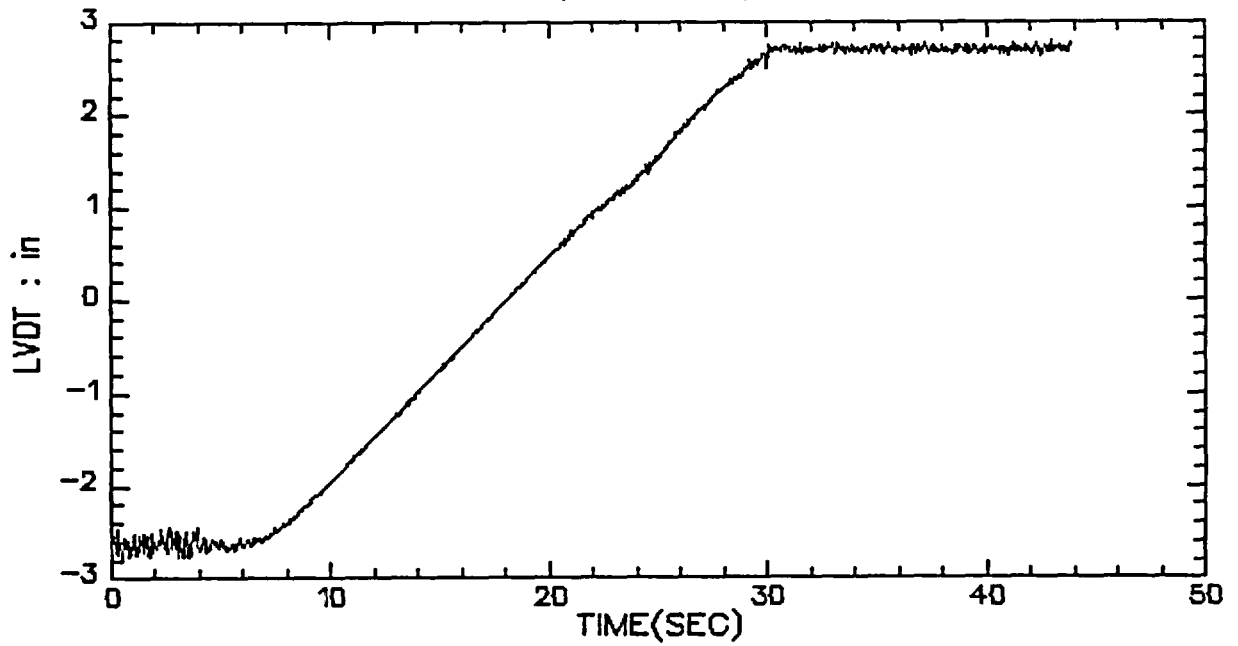

VALVE A, TEST 4, STEP 2

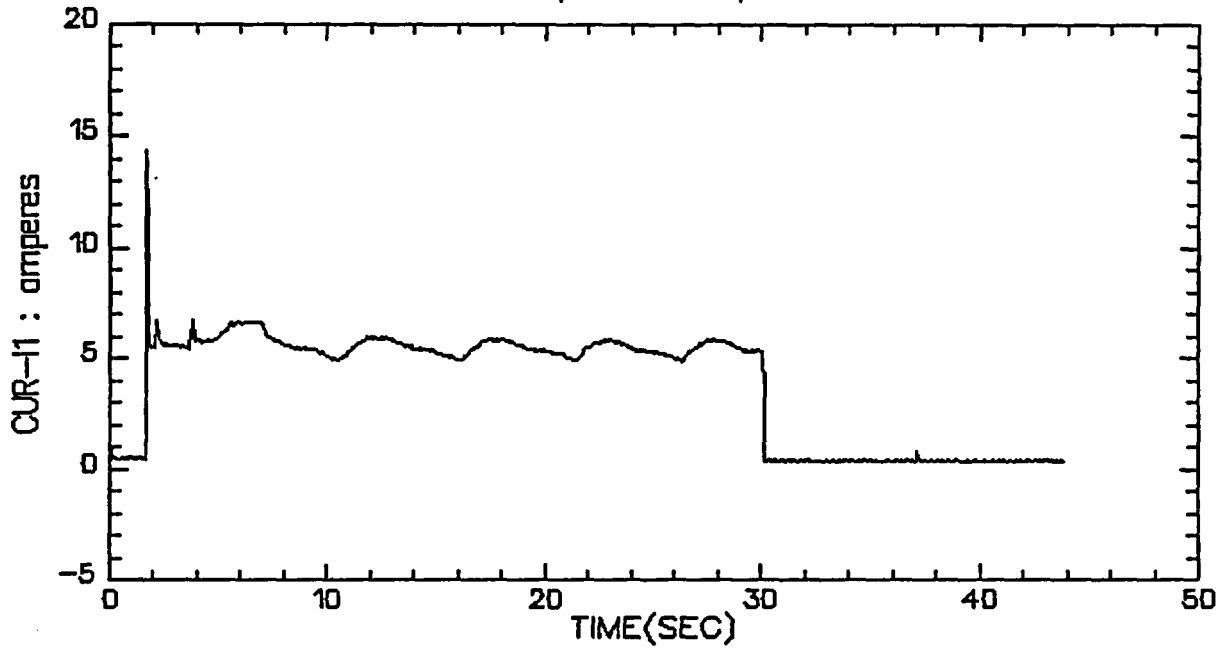

VALVE A, TEST 4, STEP 2

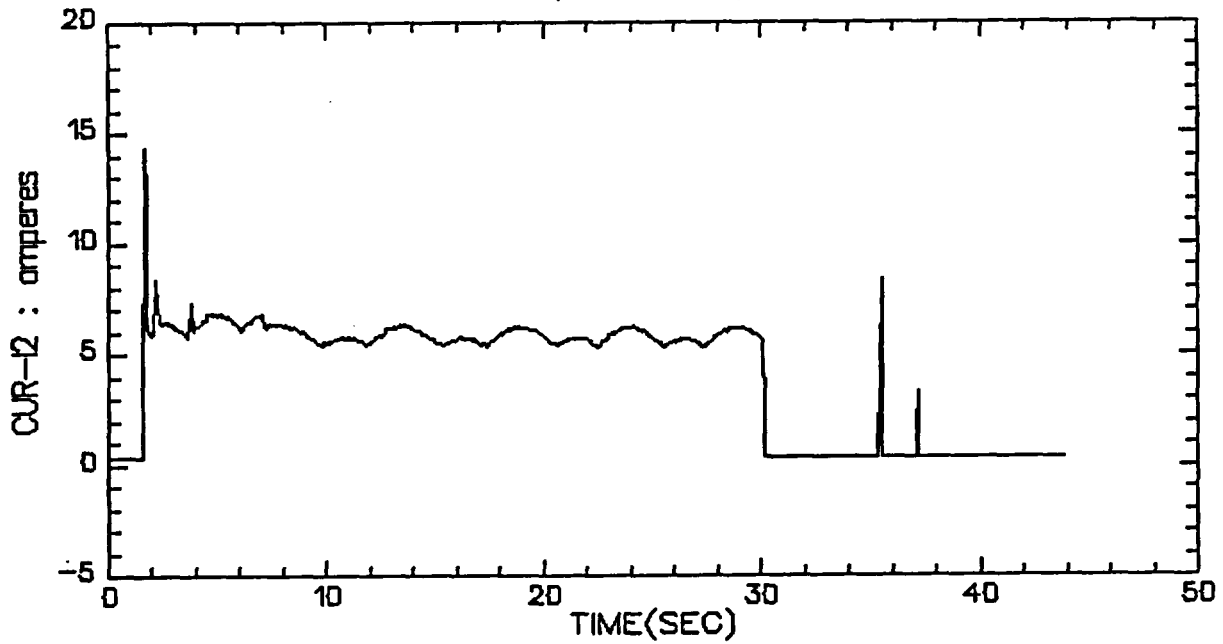

VALVE A, TEST 4, STEP 2

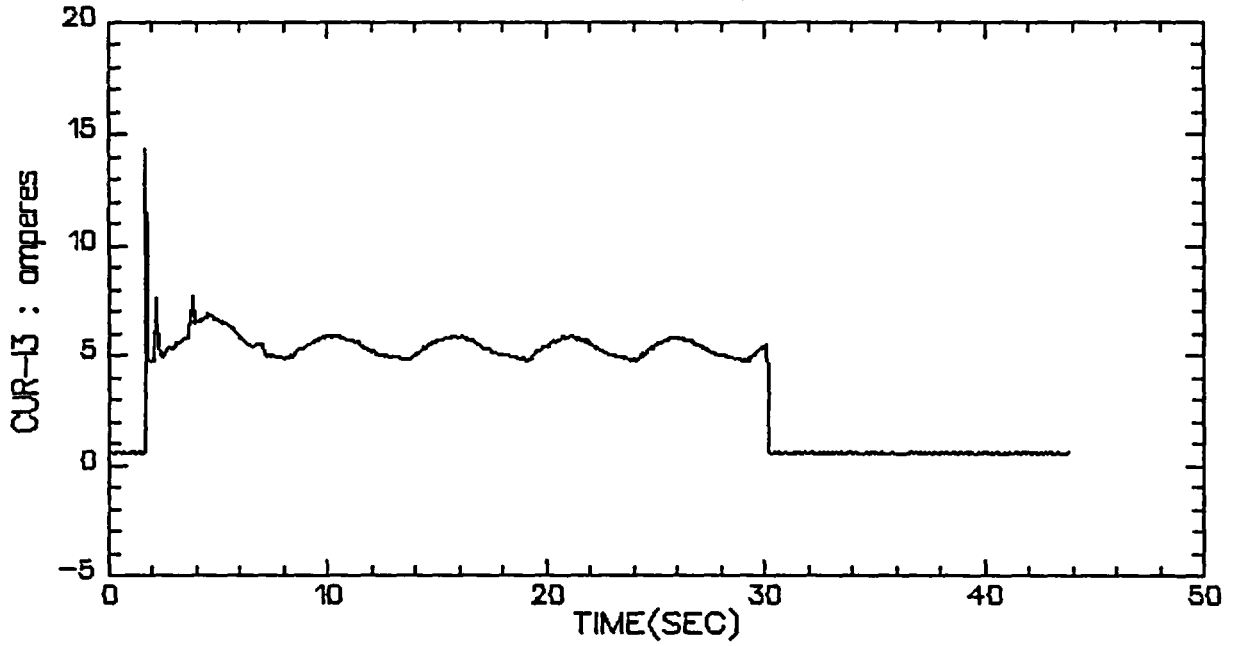

VALVE A, TEST 4, STEP 2

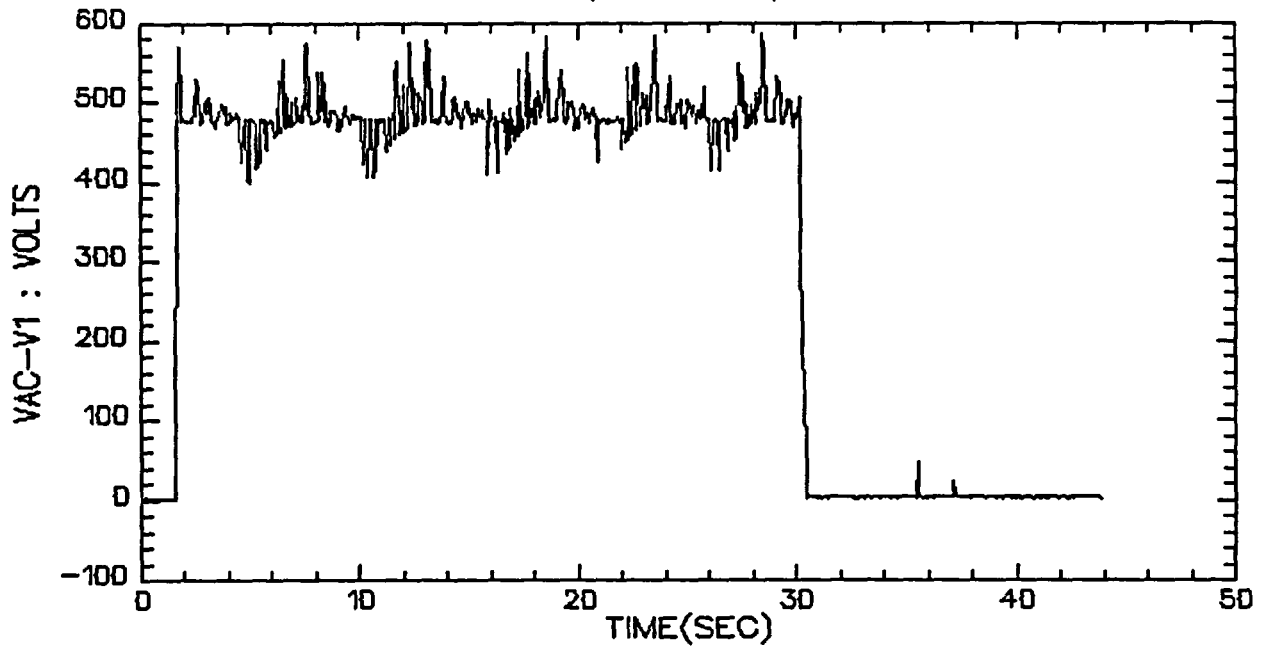

VALVE A, TEST 4, STEP 2

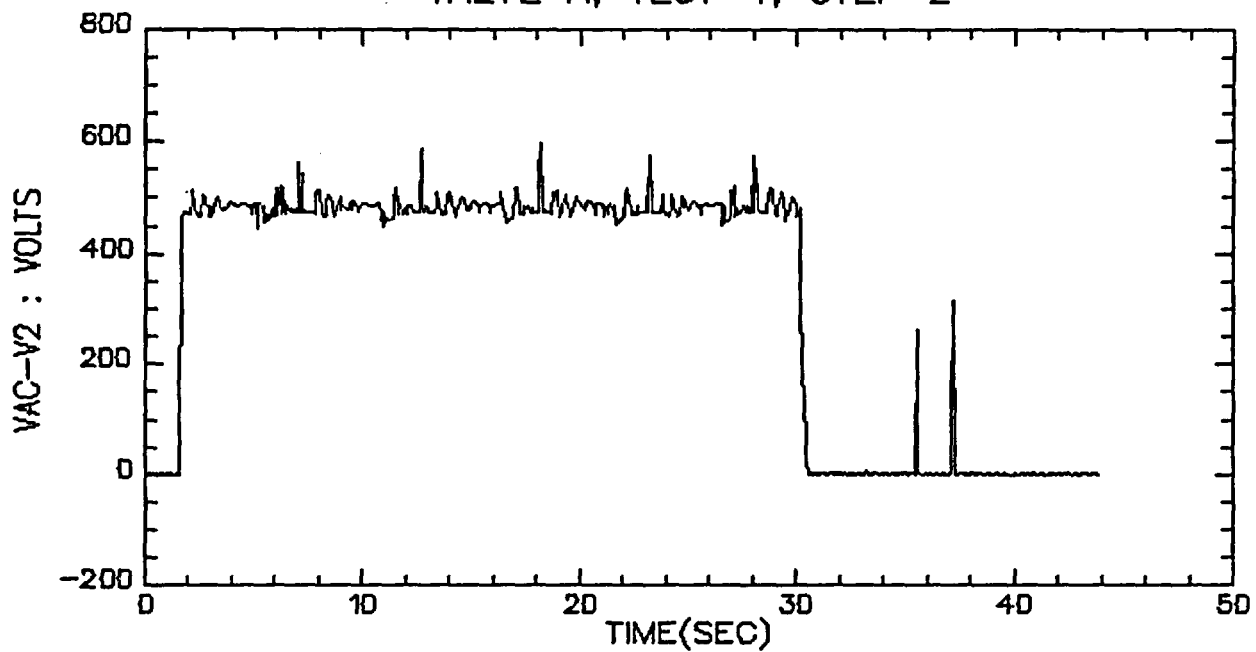

VALVE A, TEST 4, STEP 2

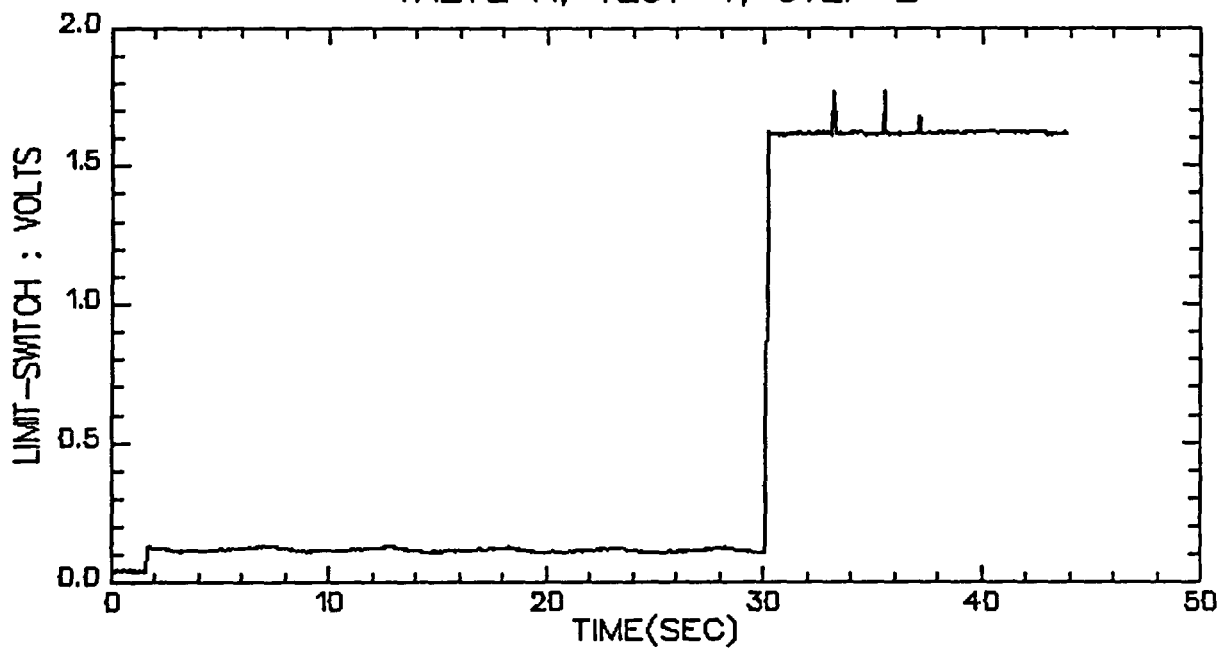

VALVE A, TEST 4, STEP 2

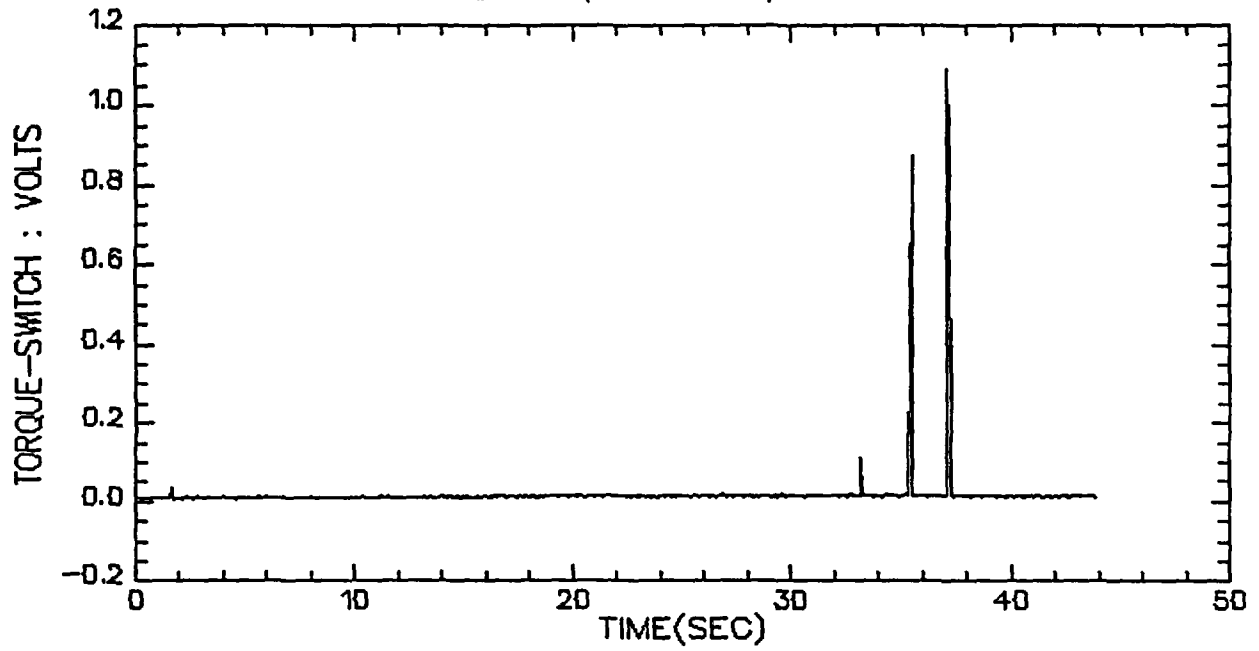

VALVE A, TEST 4, STEP 2

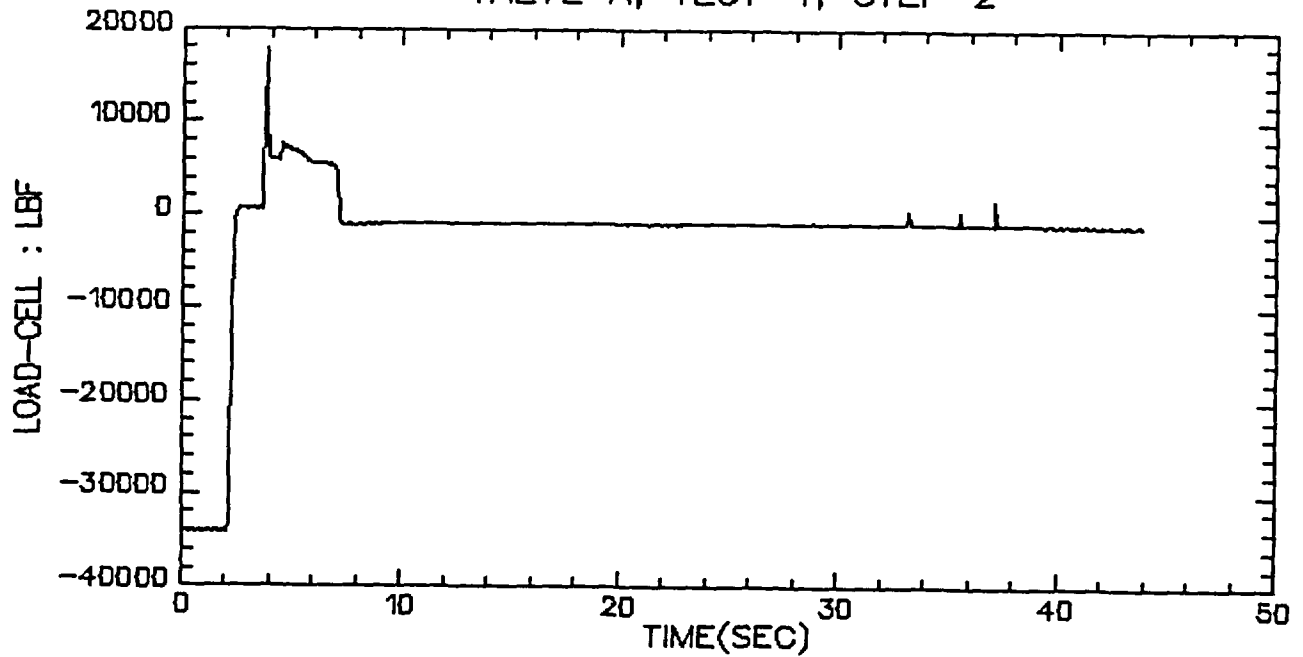

VALVE A, TEST 4, STEP 3&4

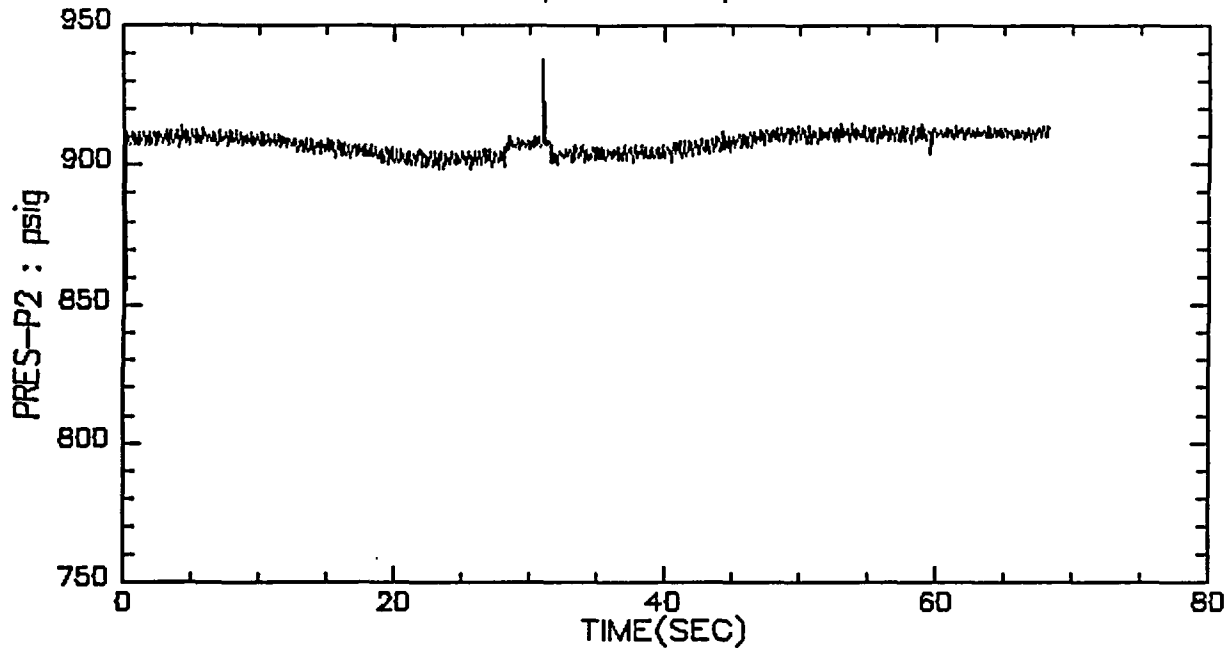

VALVE A, TEST 4, STEP 3&4

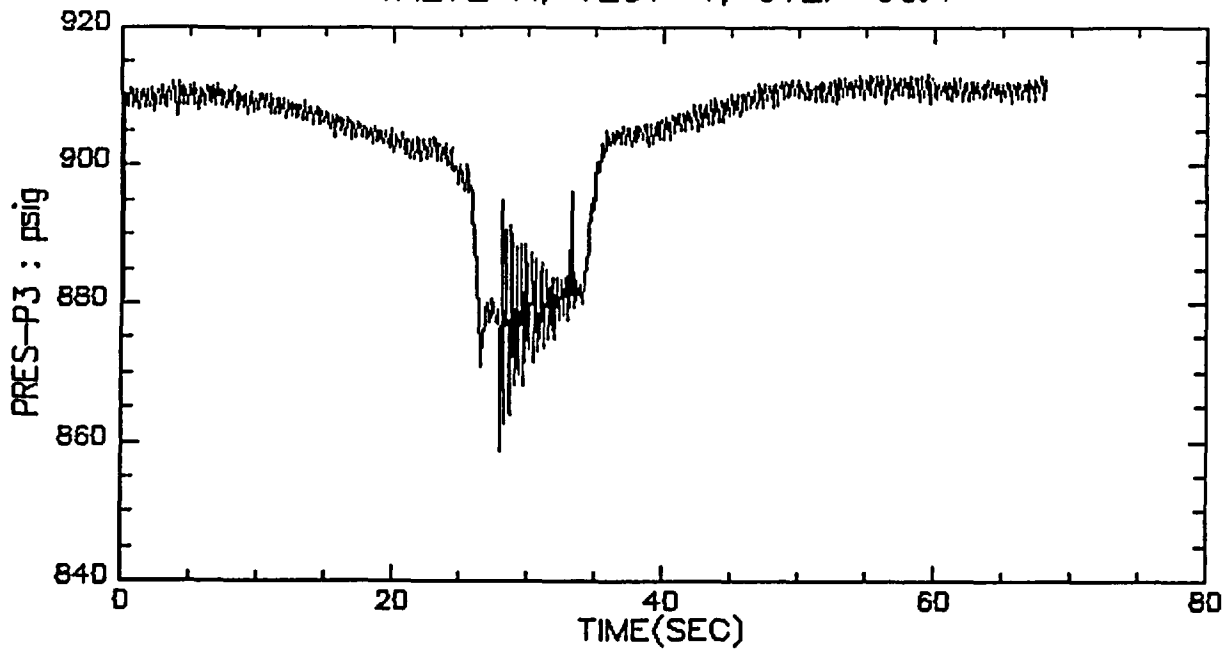

VALVE A, TEST 4, STEP 3&4

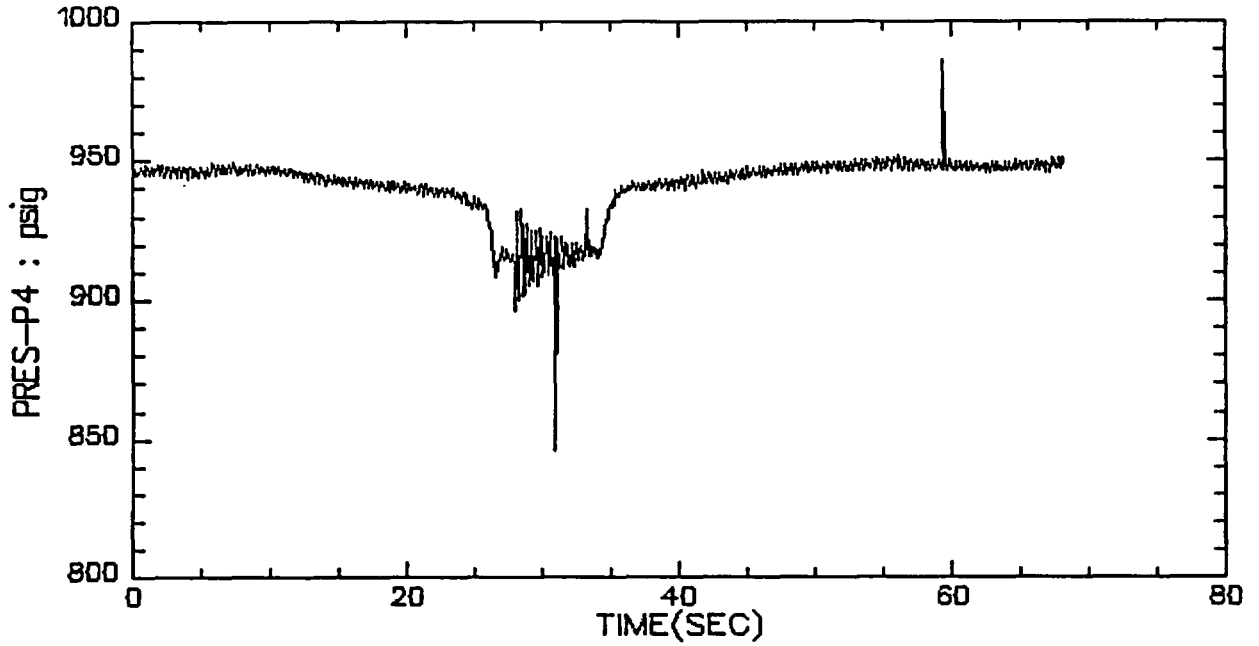

VALVE A, TEST 4, STEP 3&4

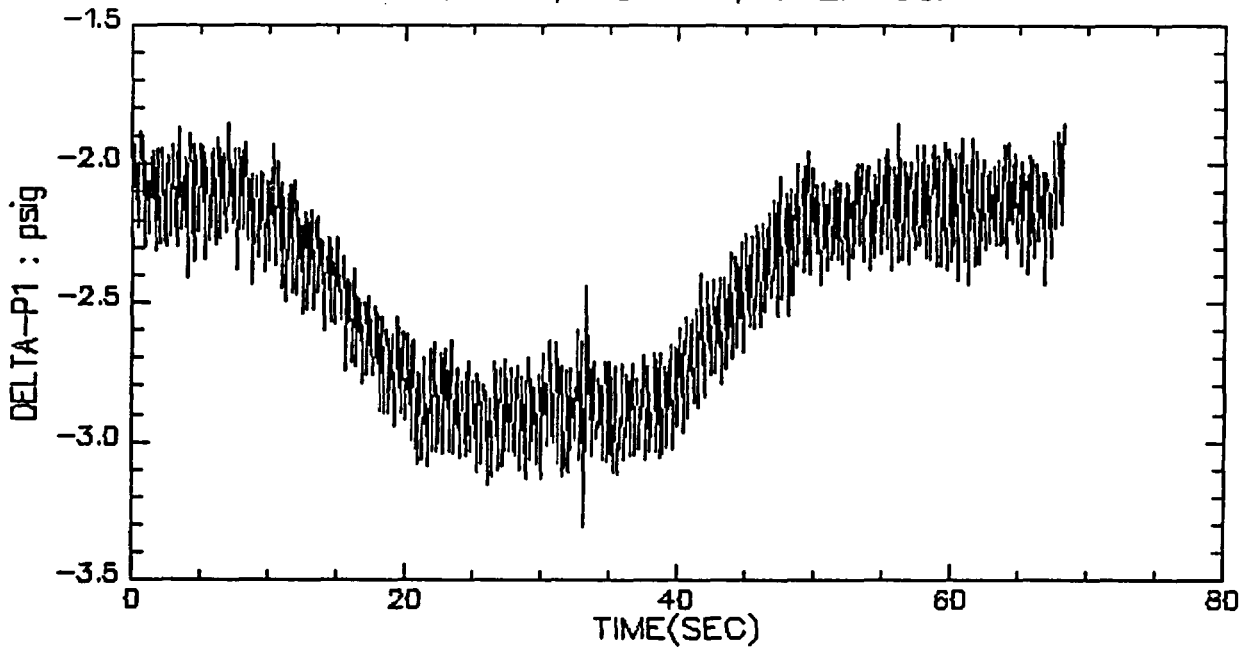

VALVE A, TEST 4, STEP 3&4

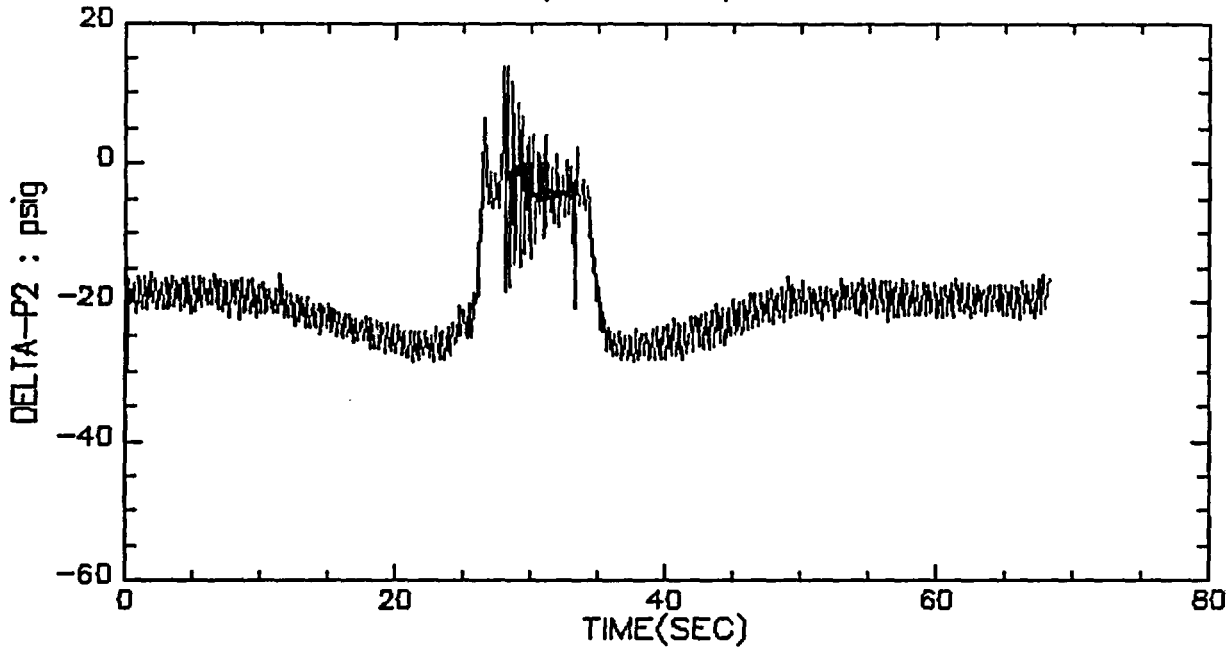

VALVE A, TEST 4, STEP 3&4

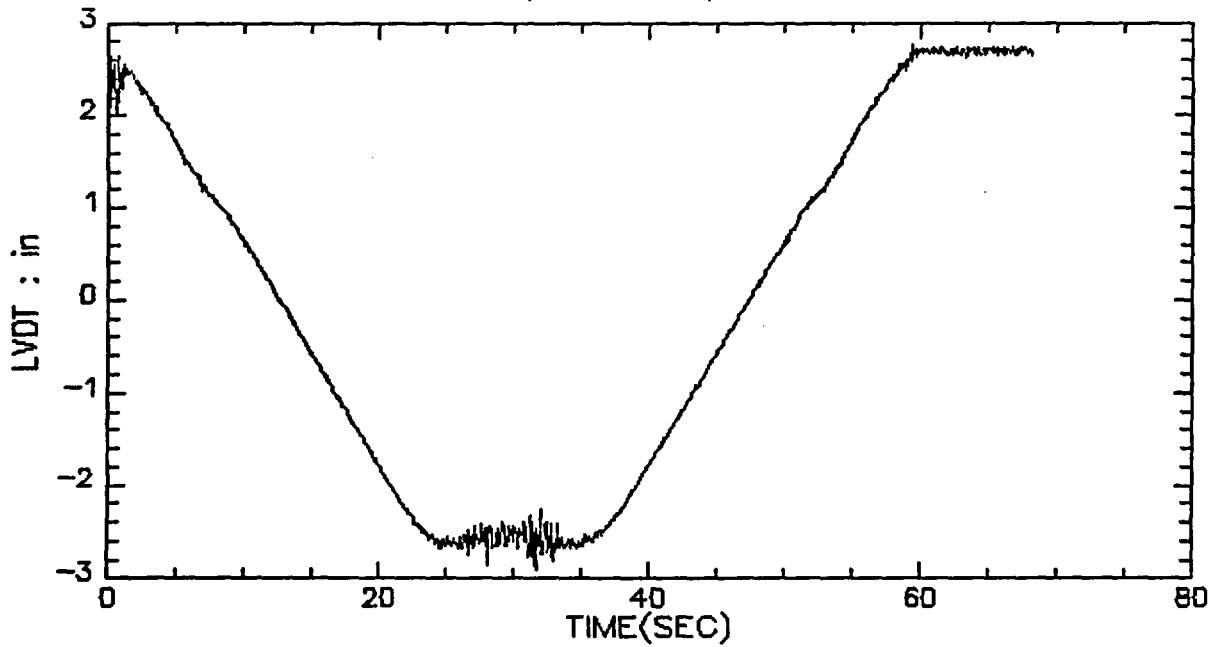

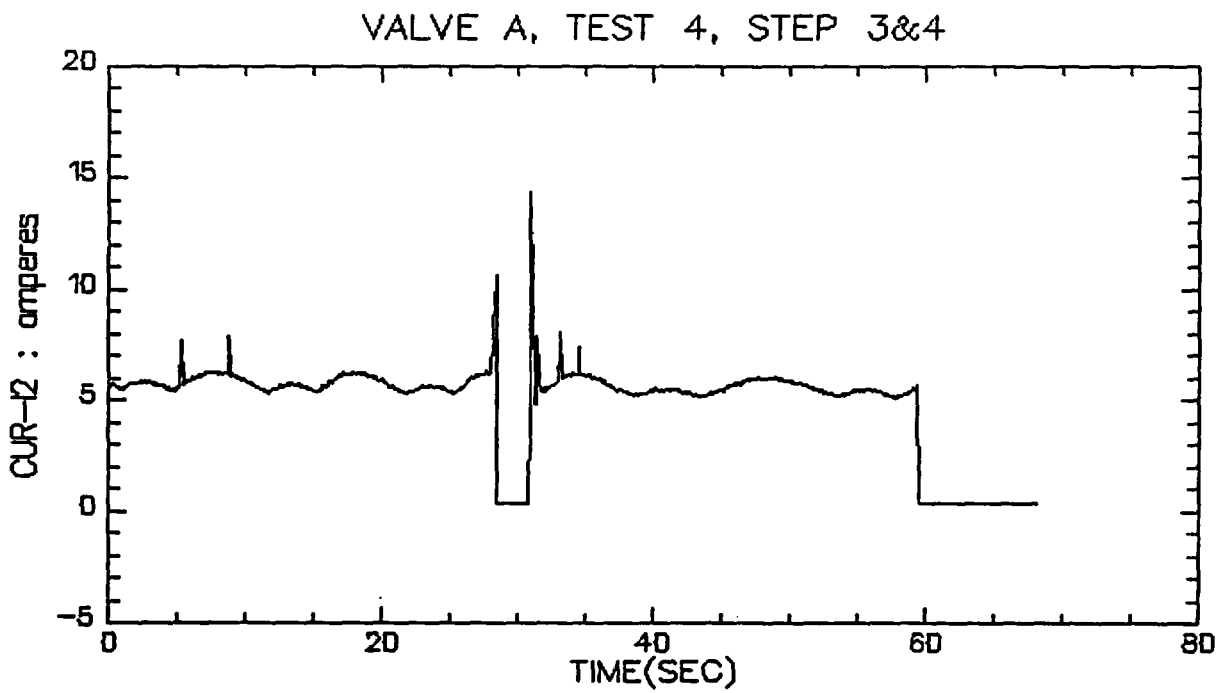
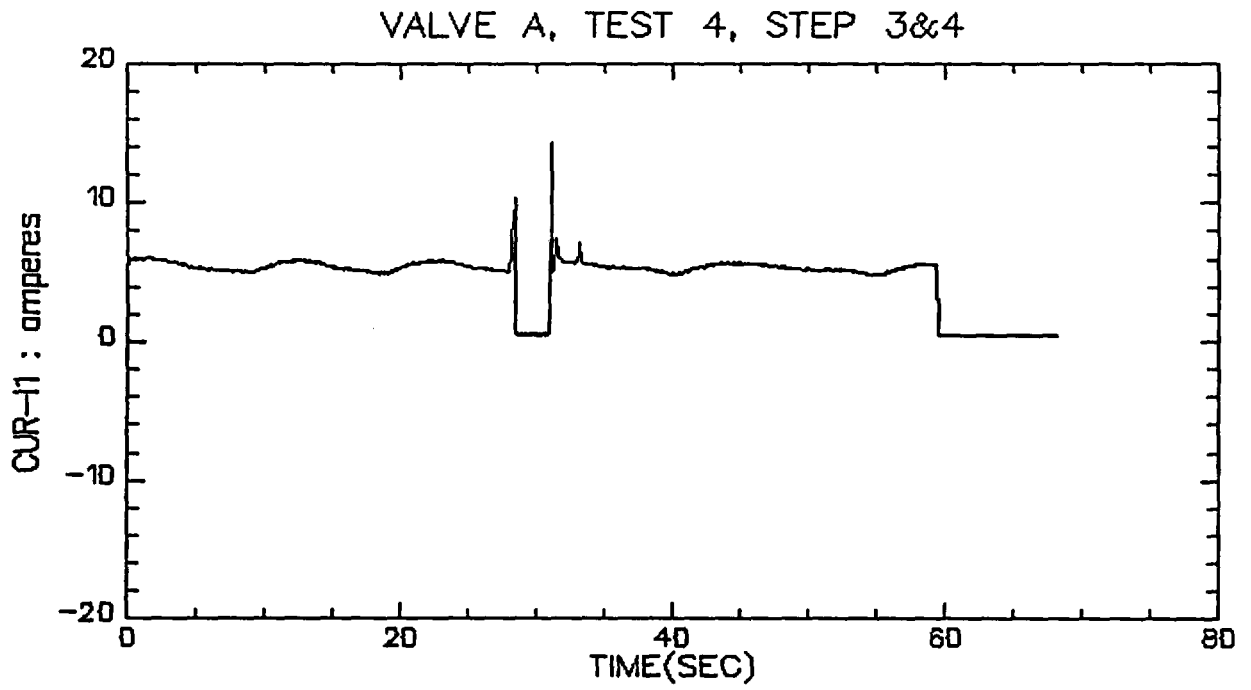

VALVE A, TEST 4, STEP 3&4

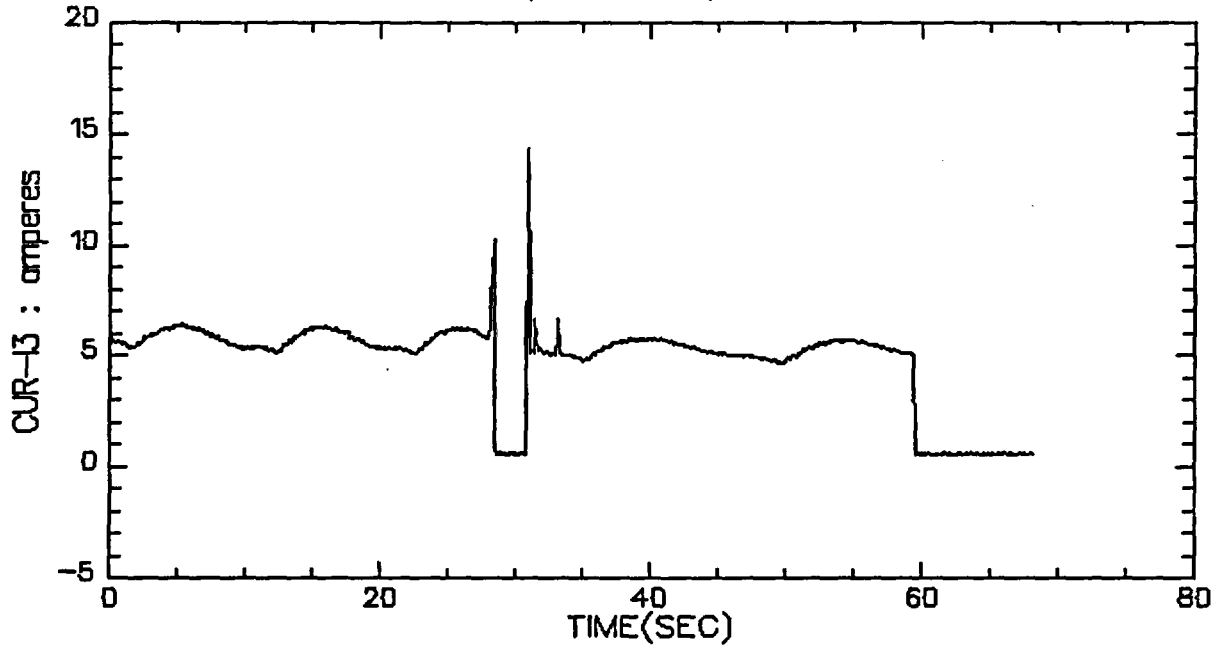

VALVE A, TEST 4, STEP 3&4

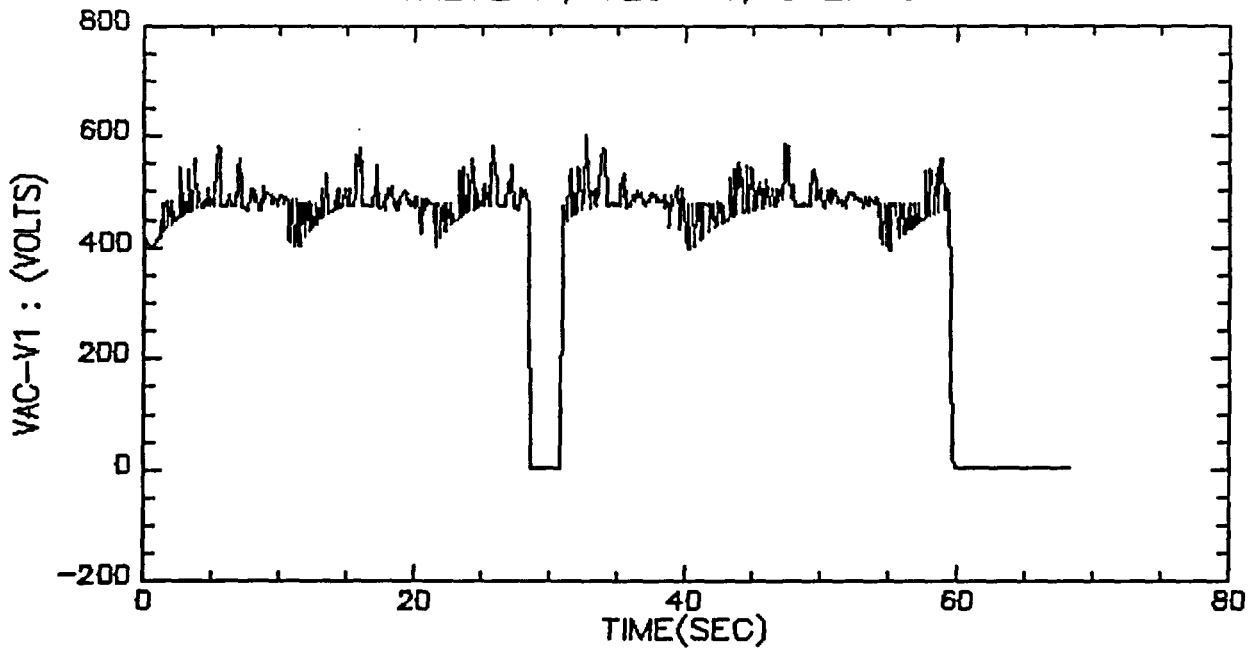

VALVE A, TEST 4, STEP 3&4

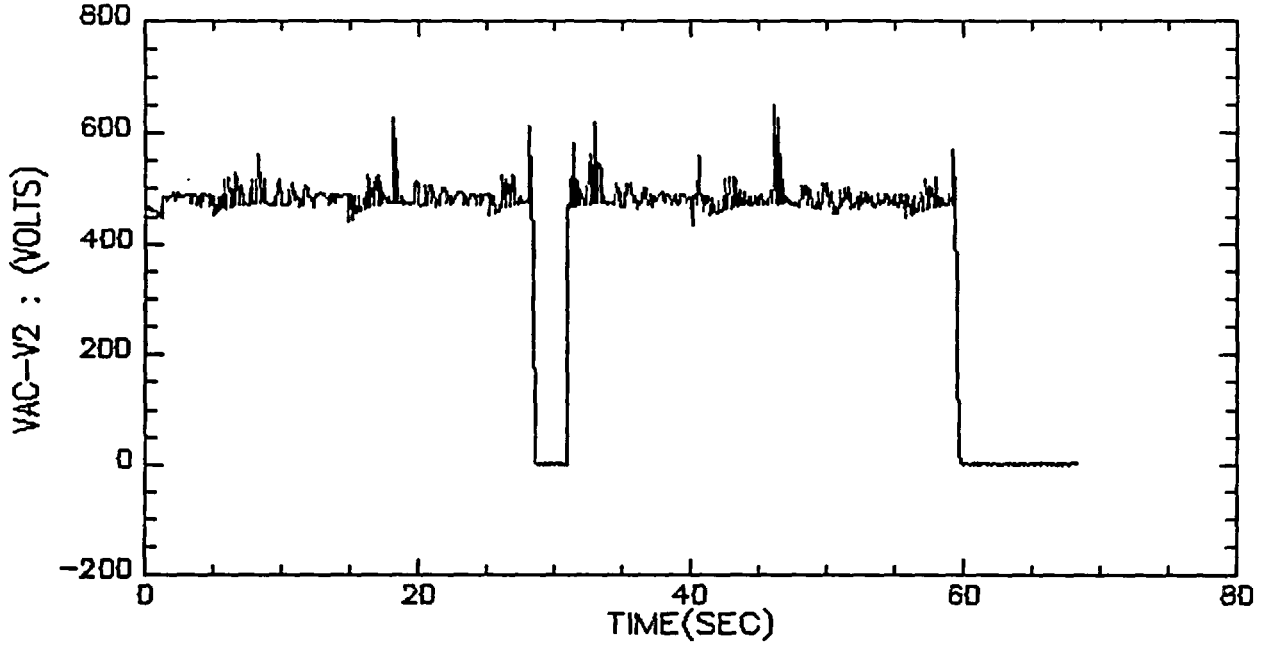

VALVE A, TEST 4, STEP 3&4

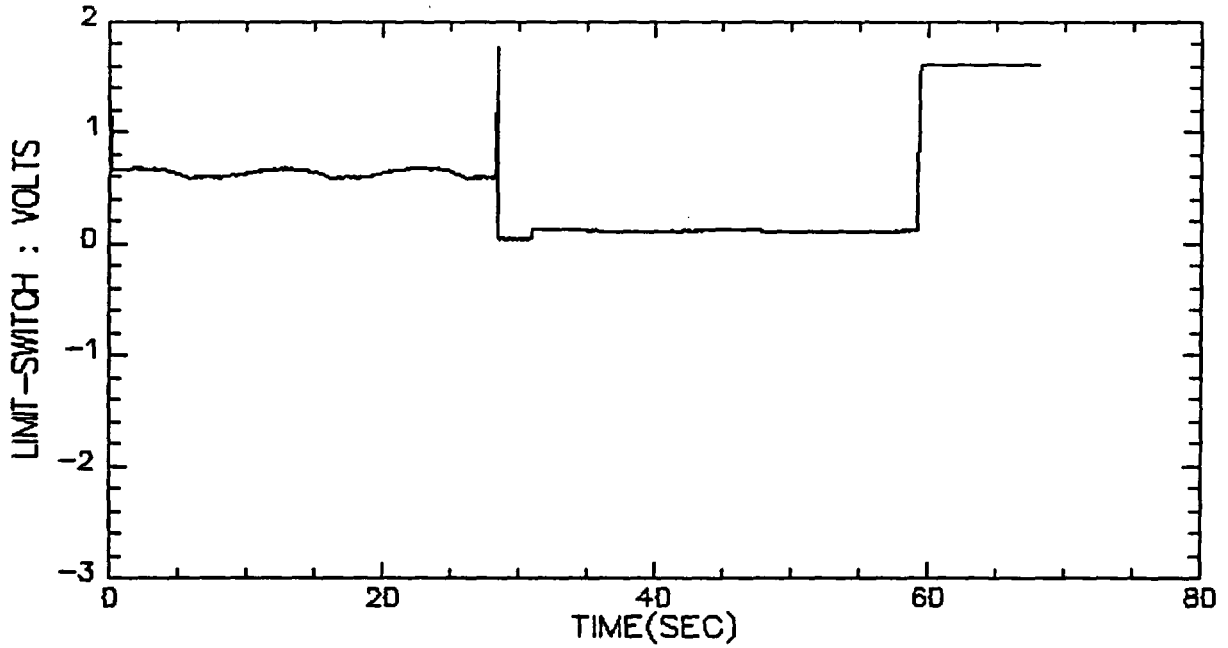

VALVE A, TEST 4, STEP 3&4

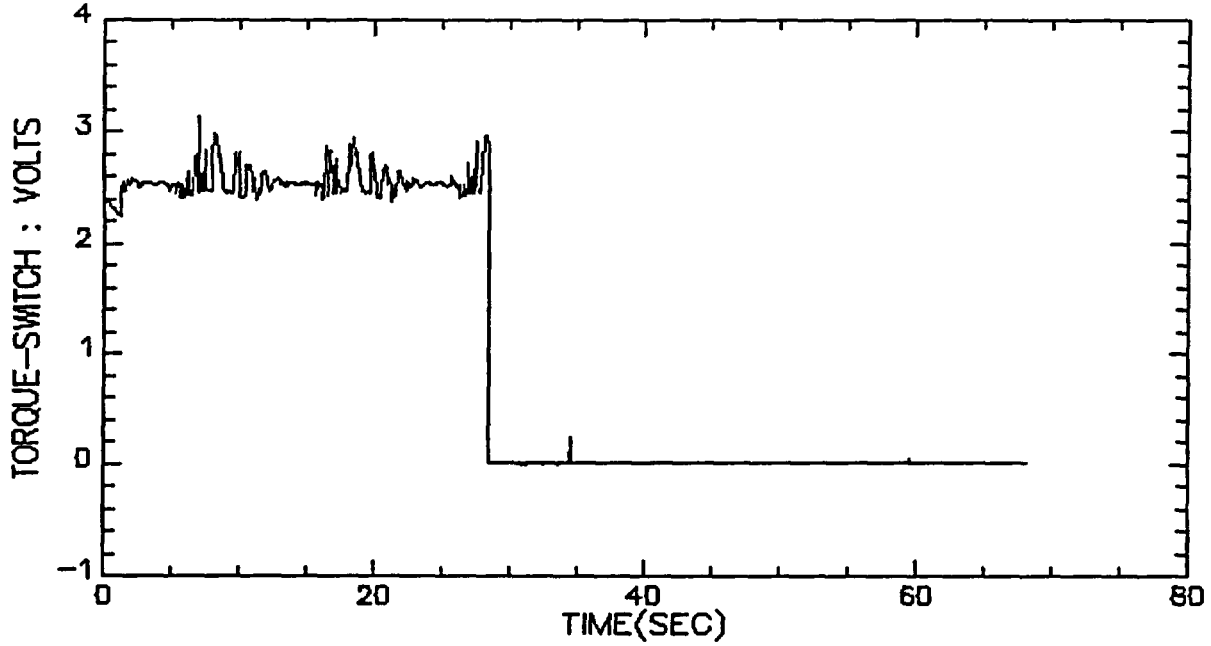

VALVE A, TEST 4, STEP 3&4

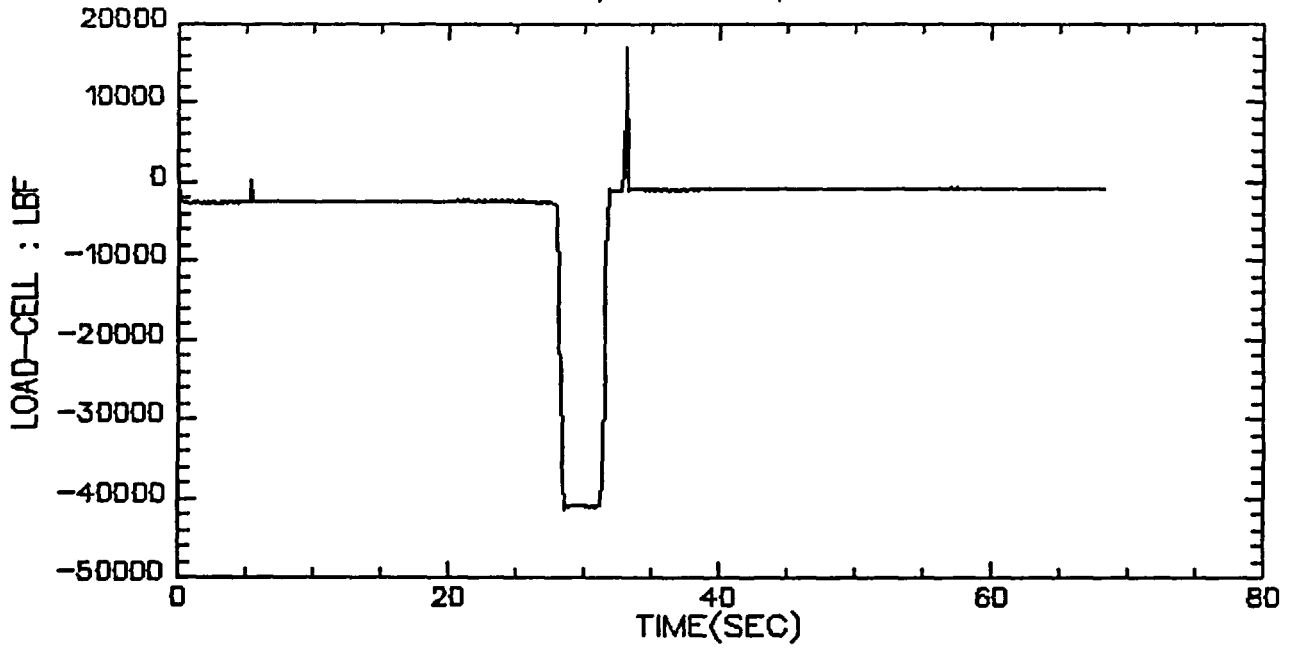

VALVE A, TEST 4, STEP 5

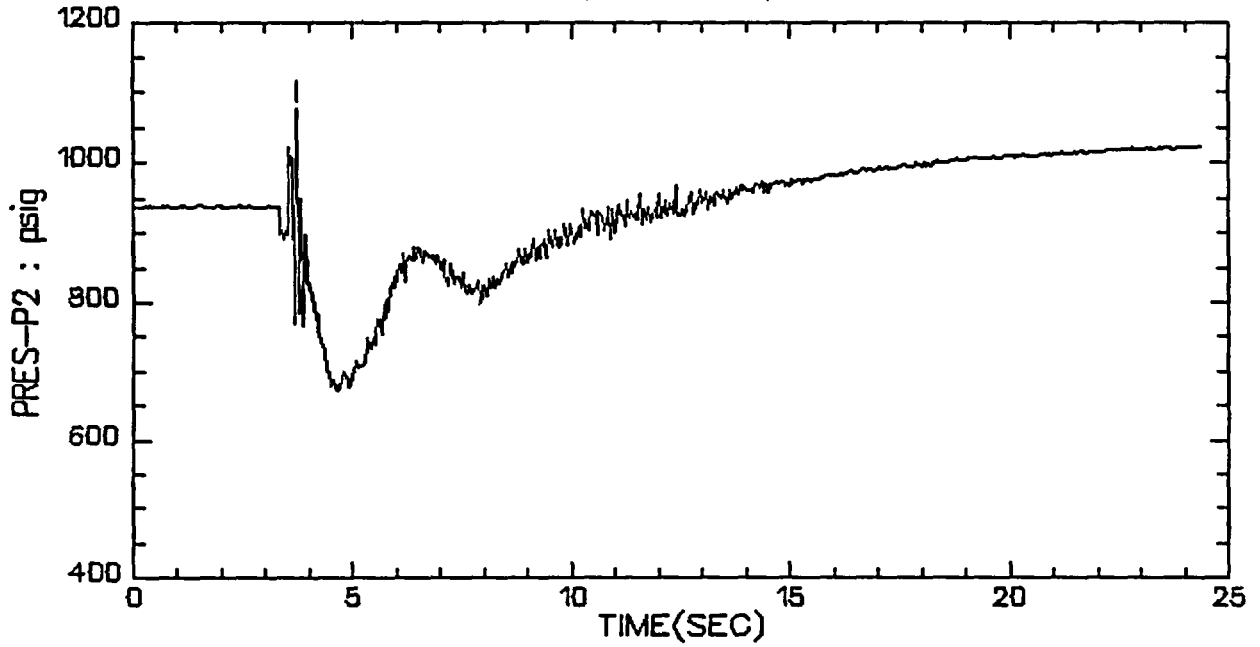

VALVE A, TEST 4, STEP 5

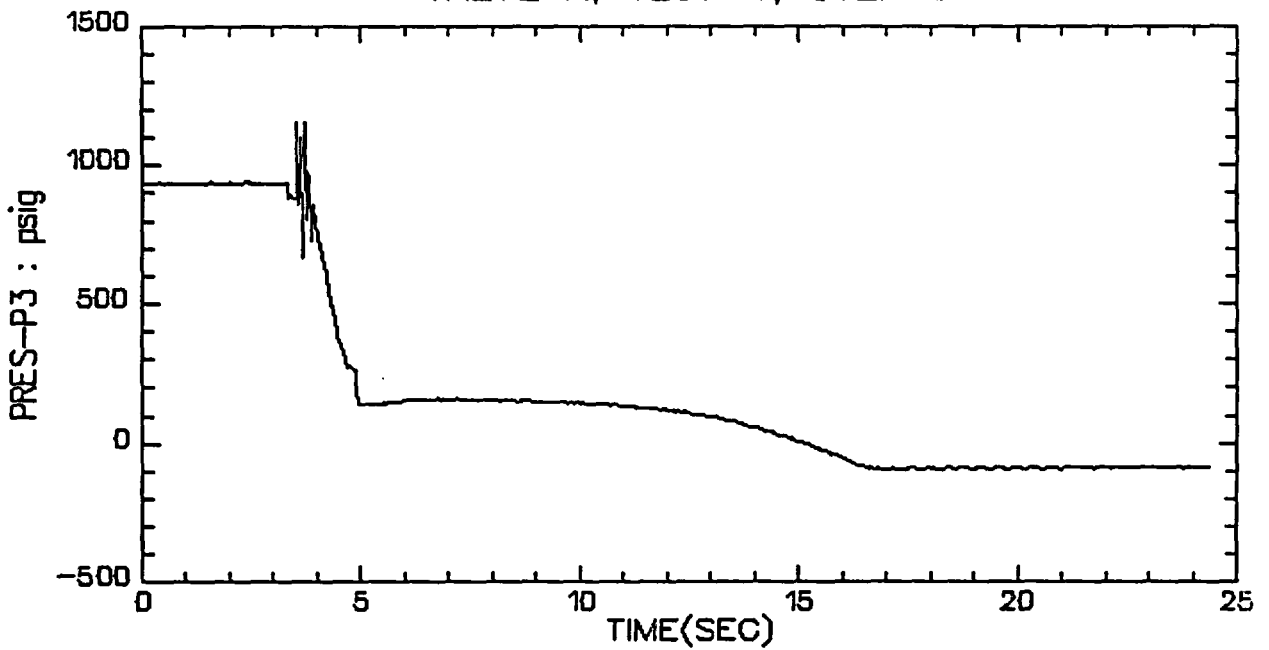

VALVE A, TEST 4, STEP 5

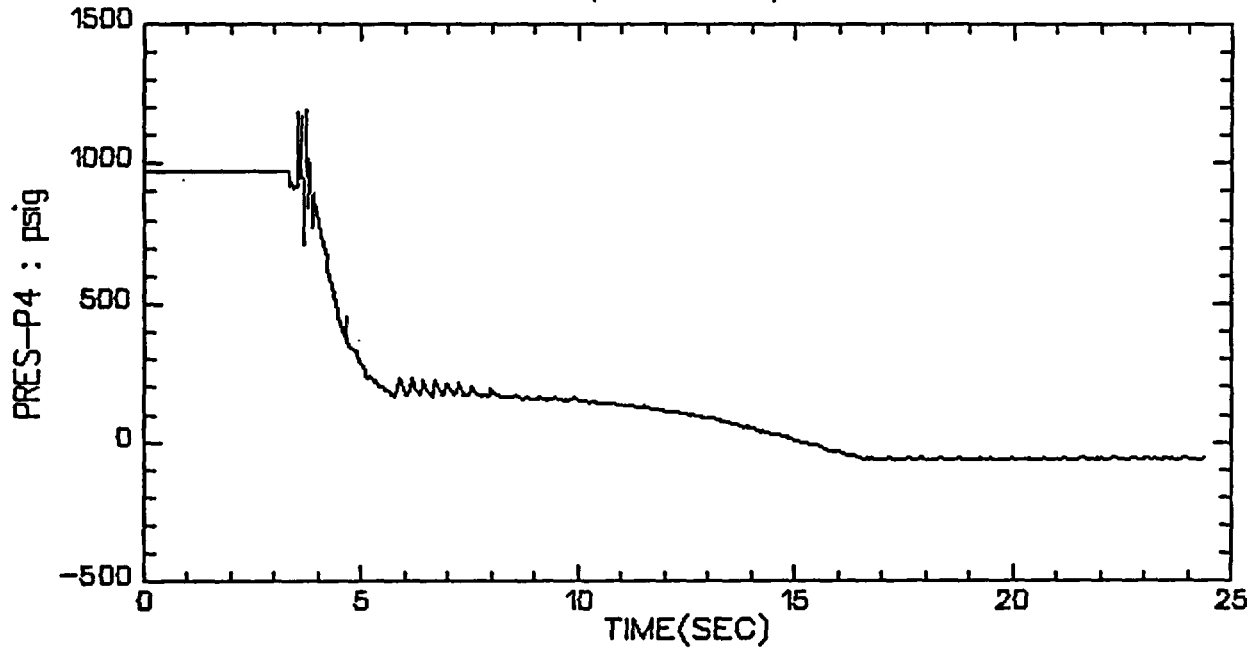

VALVE A, TEST 4, STEP 5

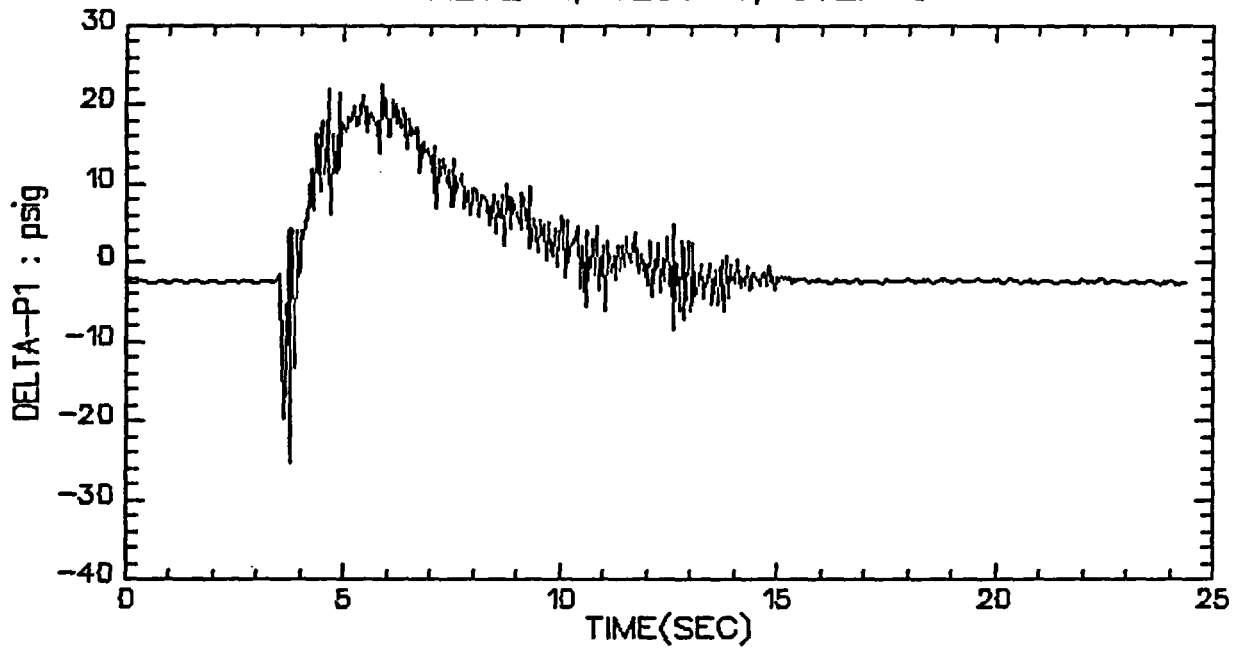

VALVE A, TEST 4, STEP 5

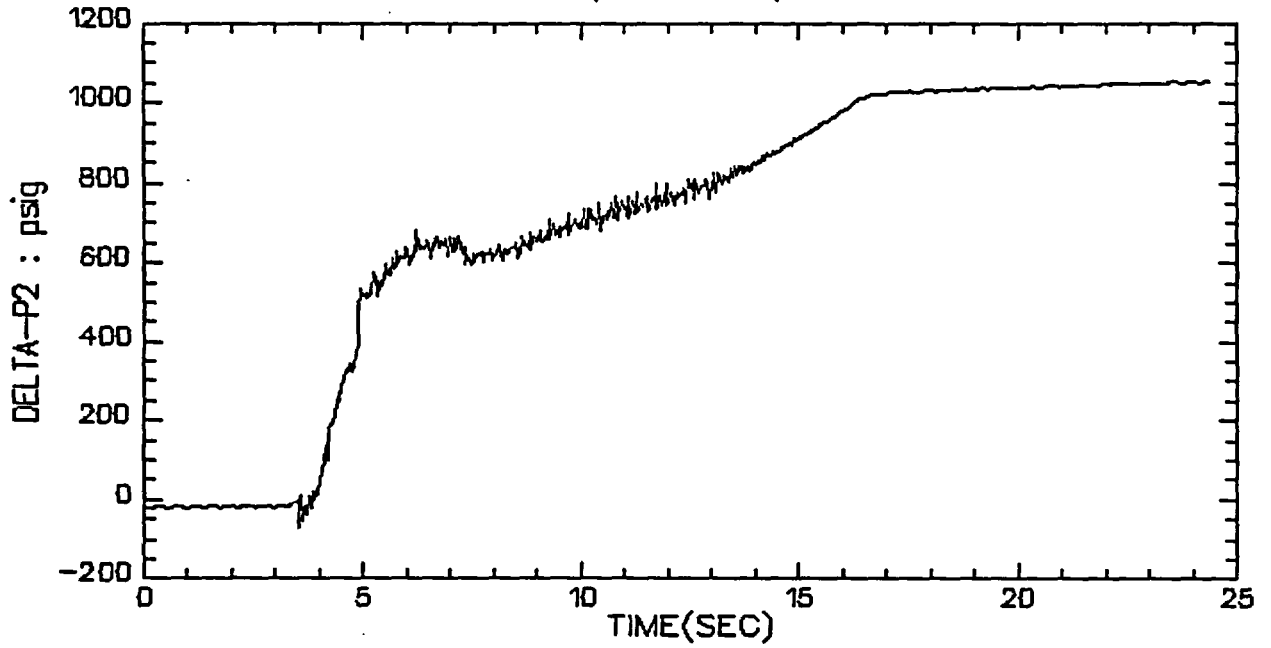

VALVE A, TEST 4, STEP 5

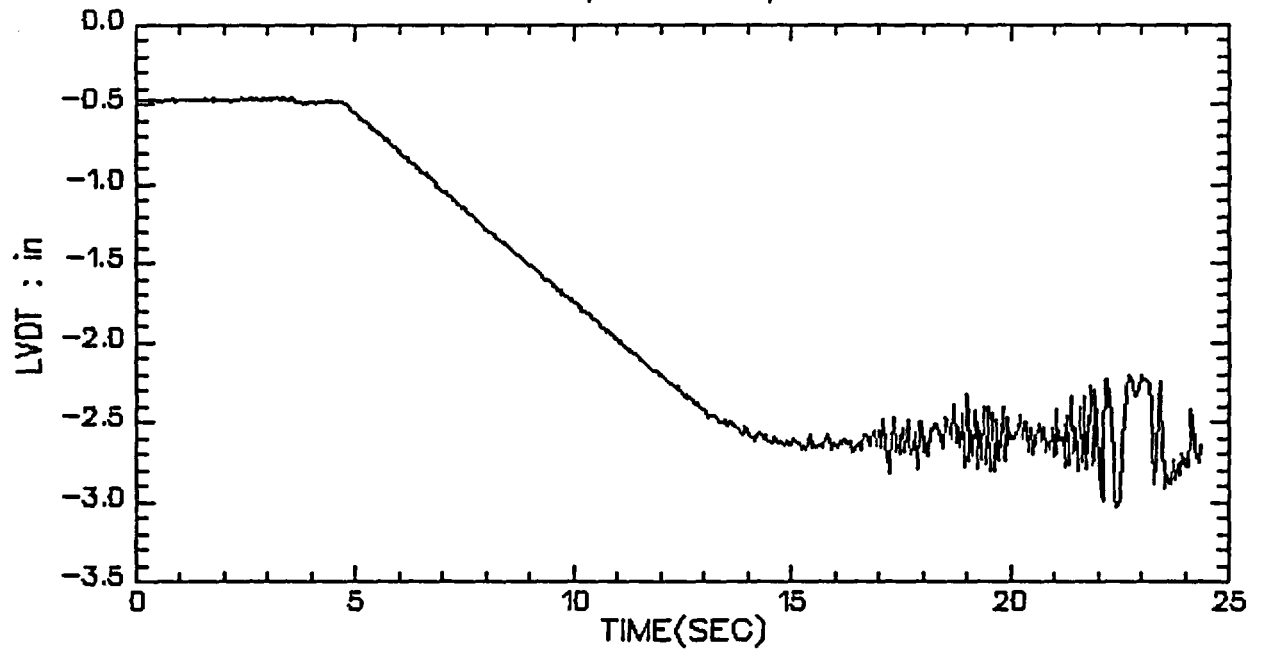

VALVE A, TEST 4, STEP 5

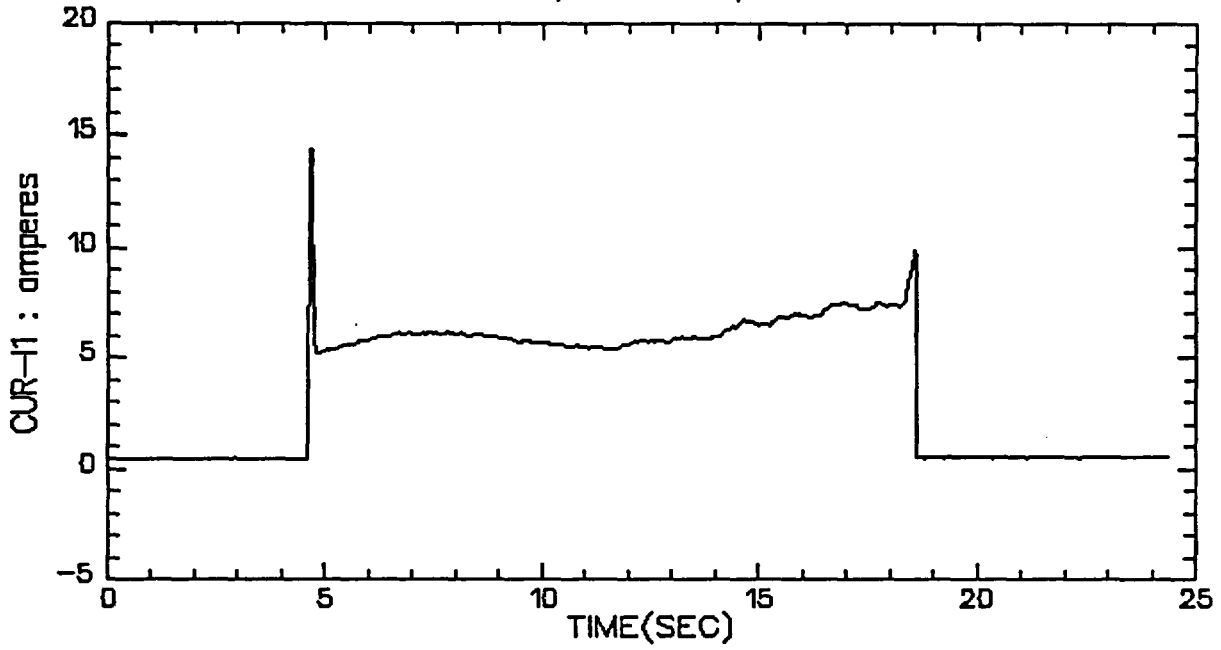

VALVE A, TEST 4, STEP 5

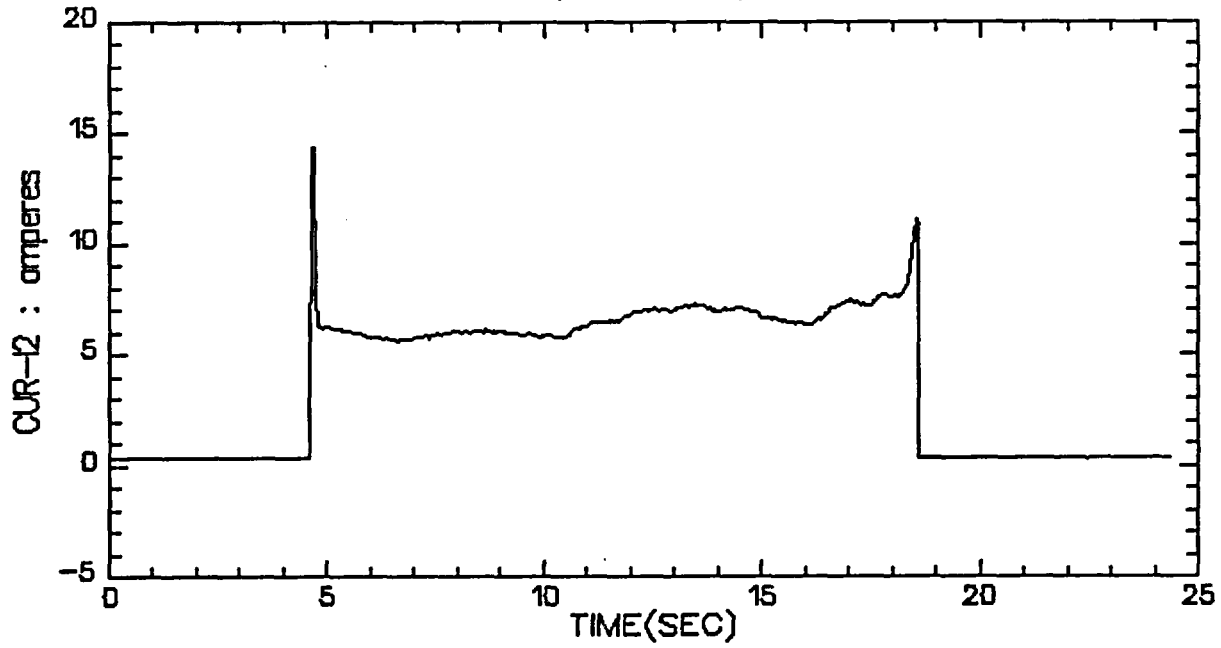

VALVE A, TEST 4, STEP 5

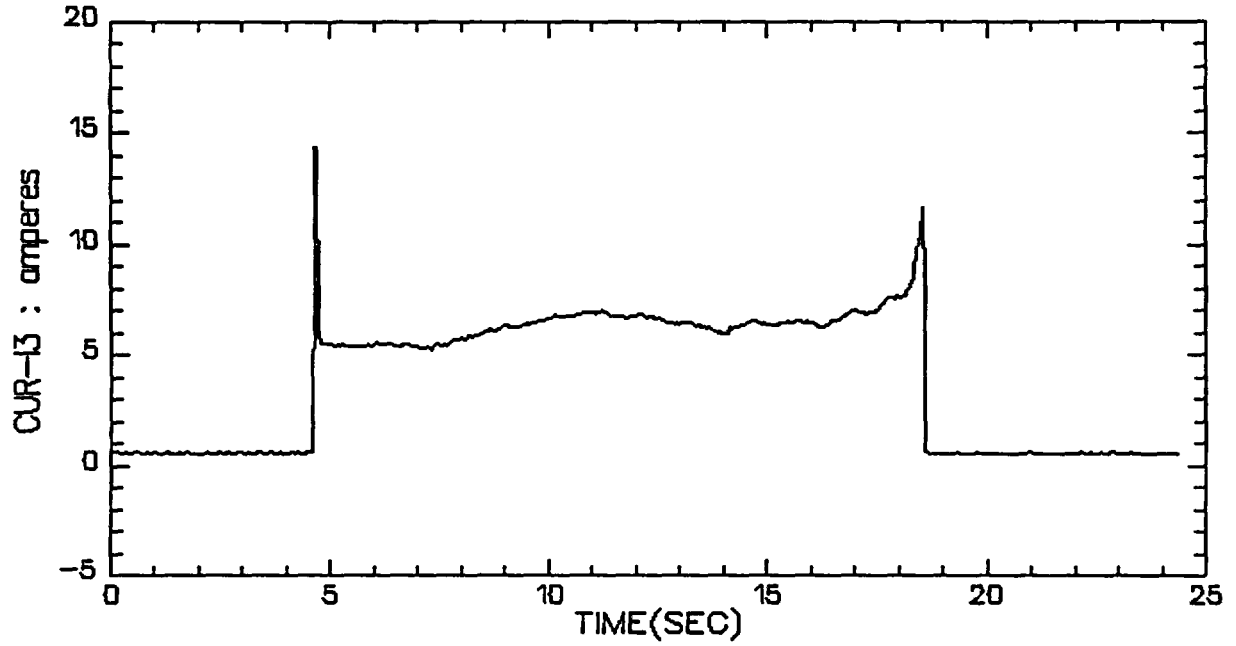

VALVE A, TEST 4, STEP 5

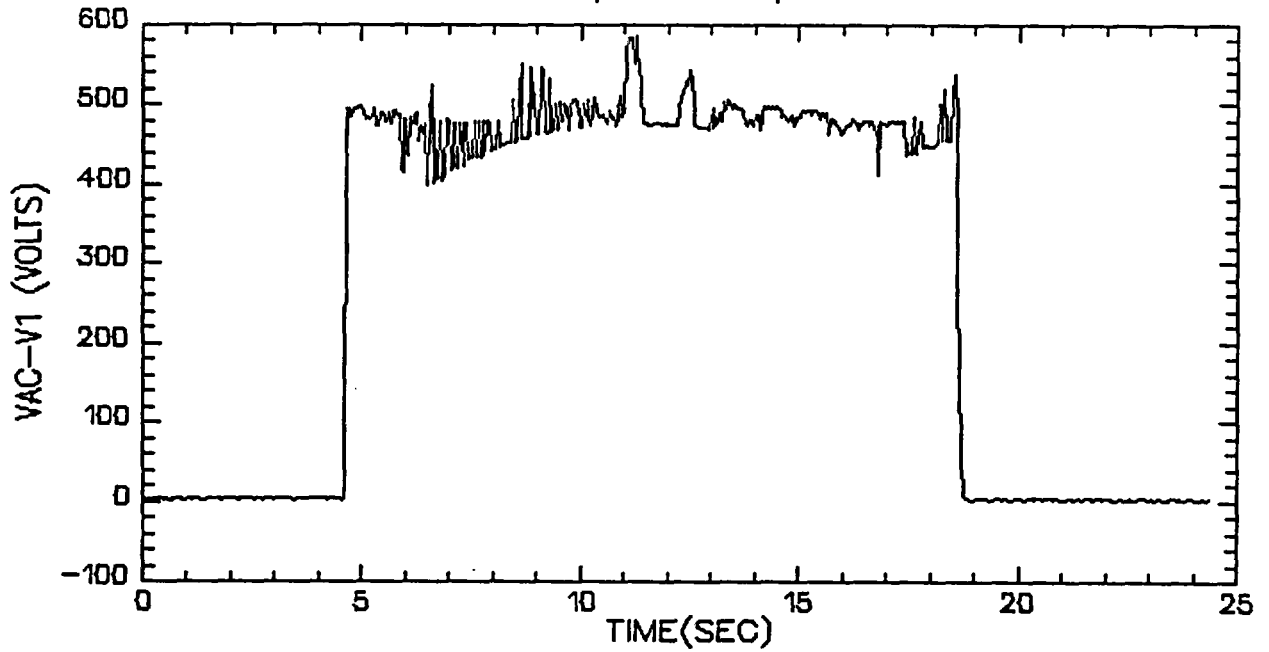

VALVE A, TEST 4, STEP 5

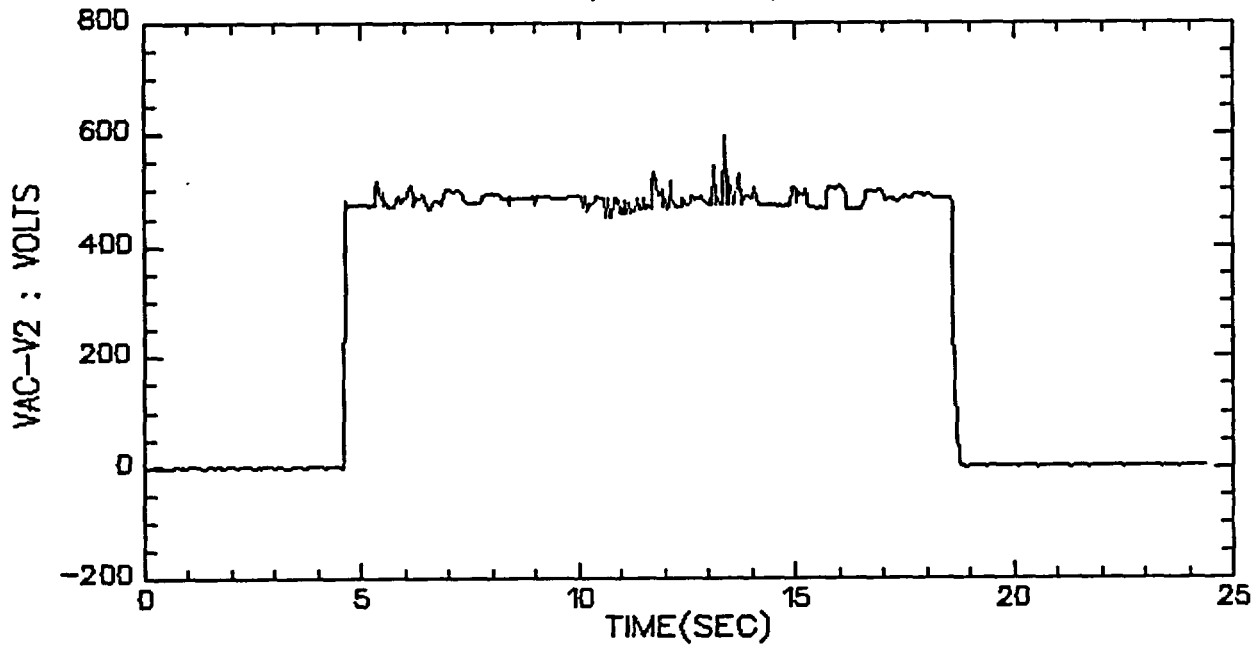

VALVE A, TEST 4, STEP 5

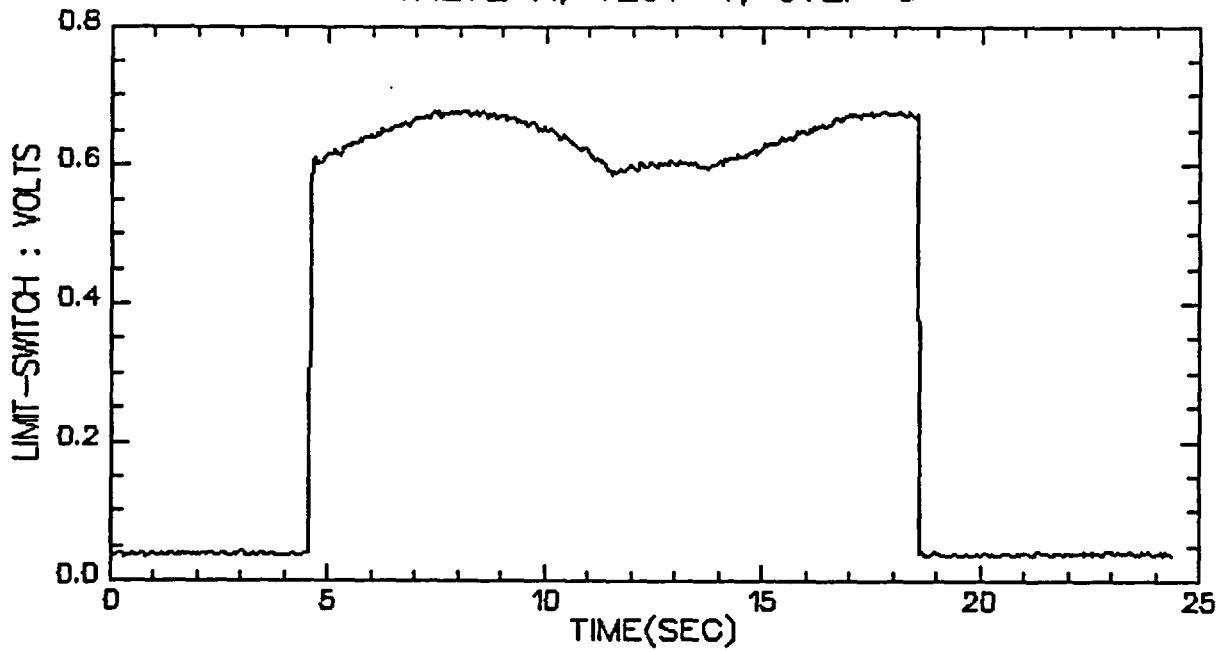

VALVE A, TEST 4, STEP 5

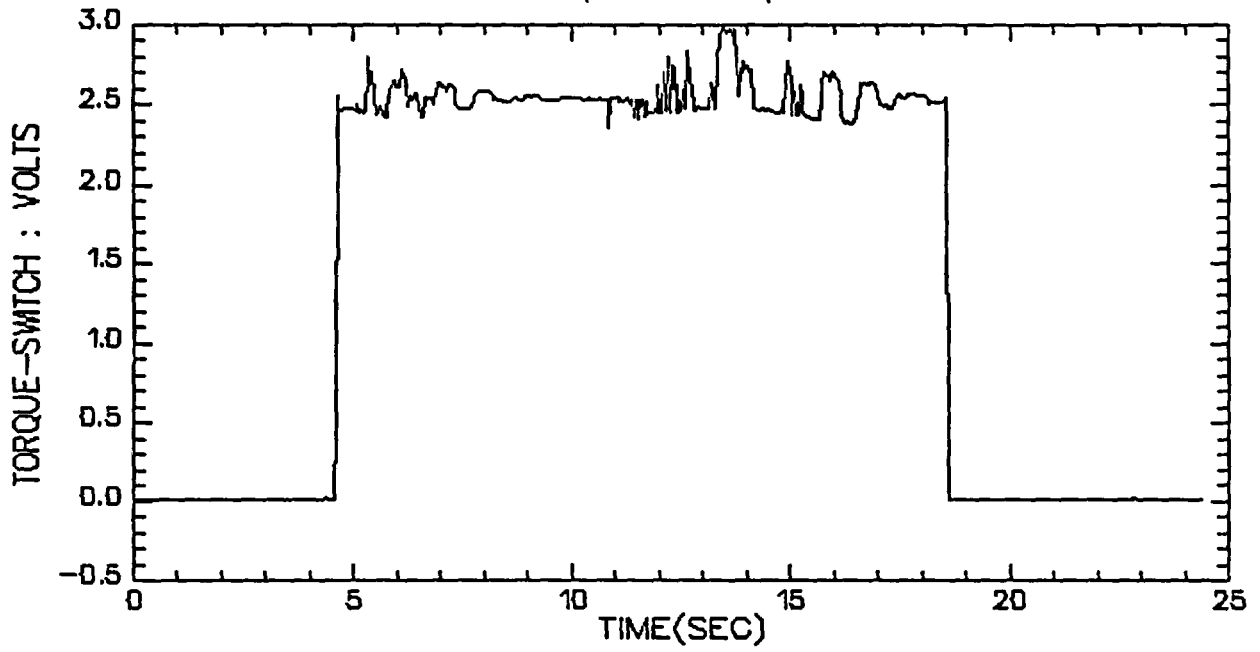

VALVE A, TEST 4, STEP 5

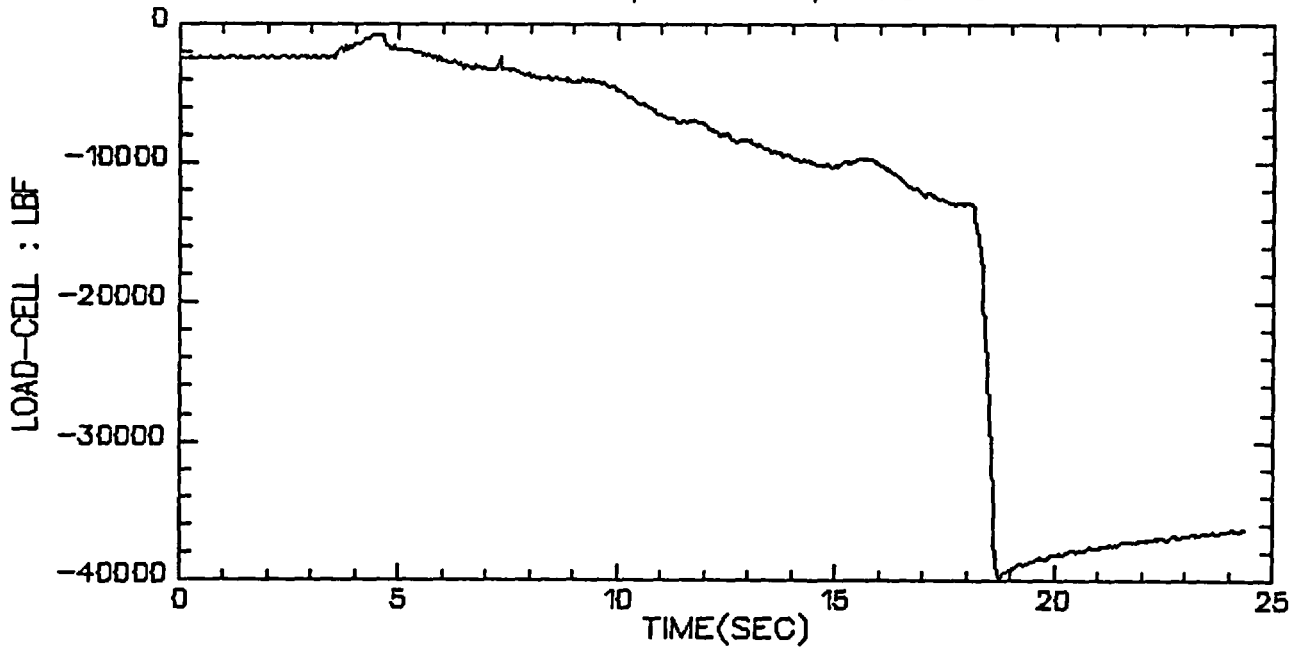

VALVE A, TEST 4, STEP 7

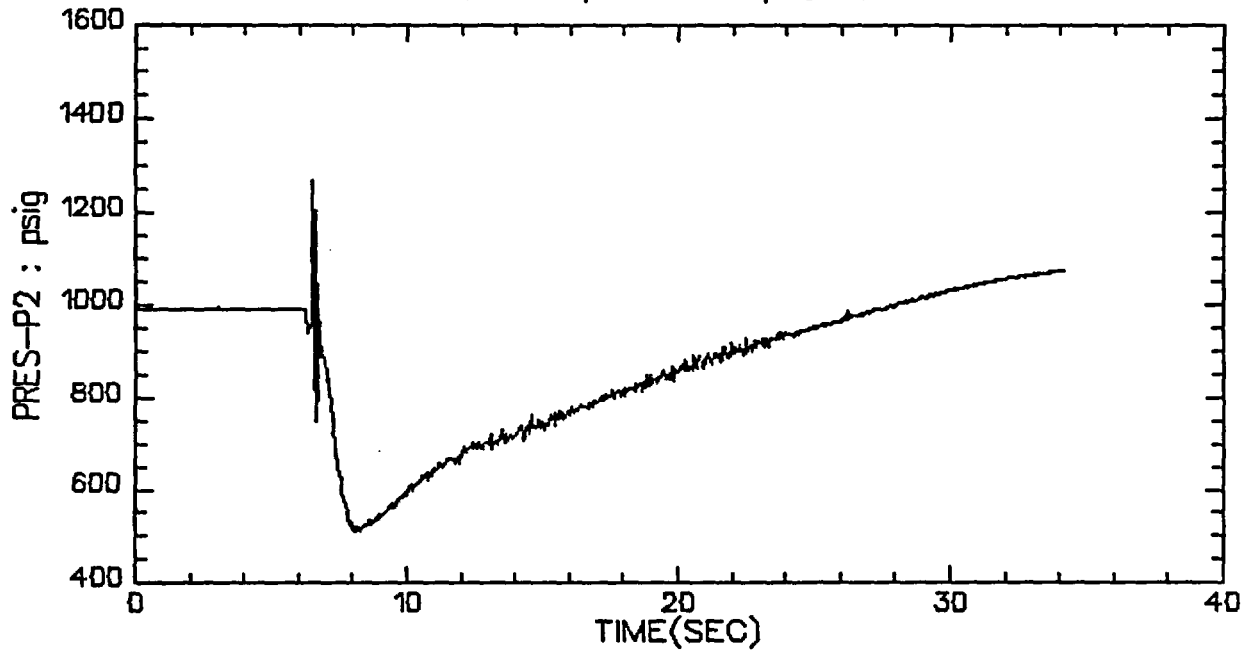

VALVE A, TEST 4, STEP 5

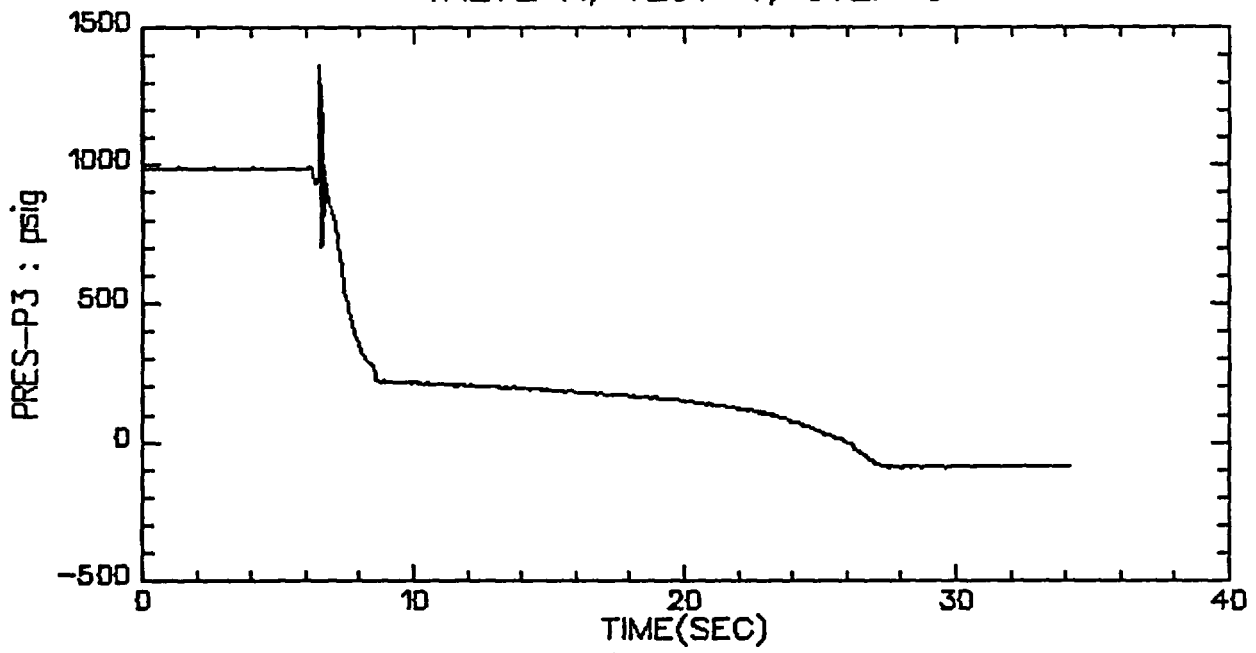

VALVE A, TEST 4, STEP 5

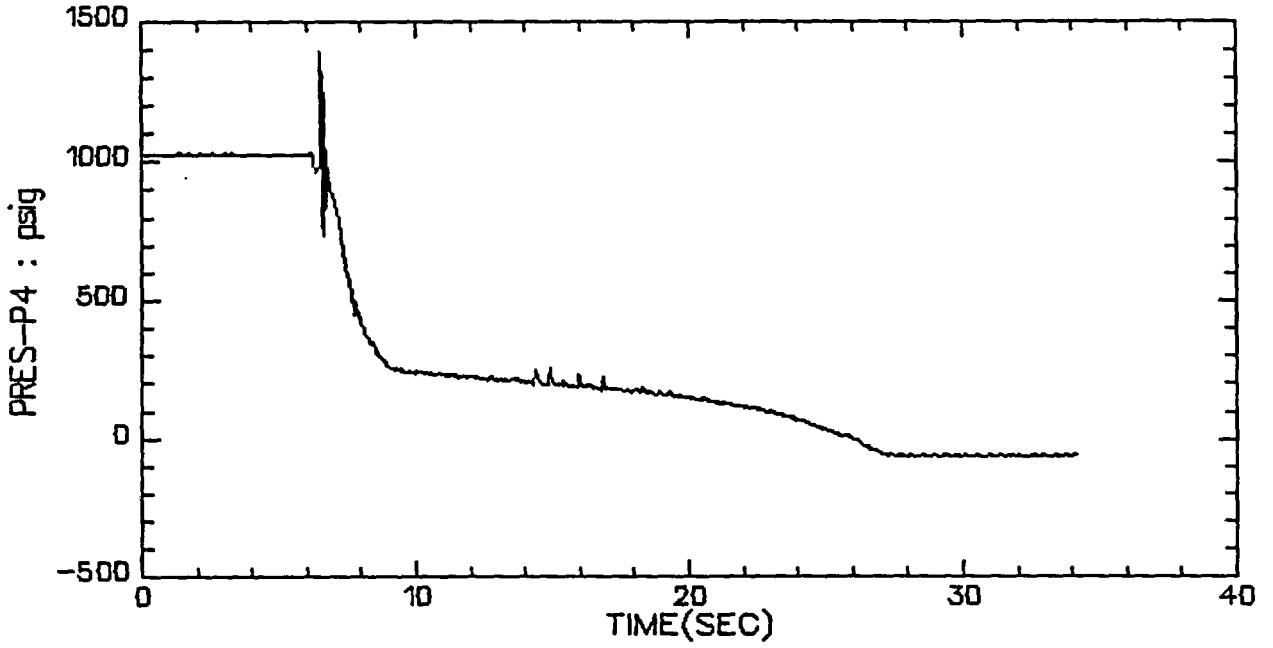

VALVE A, TEST 4, STEP 7

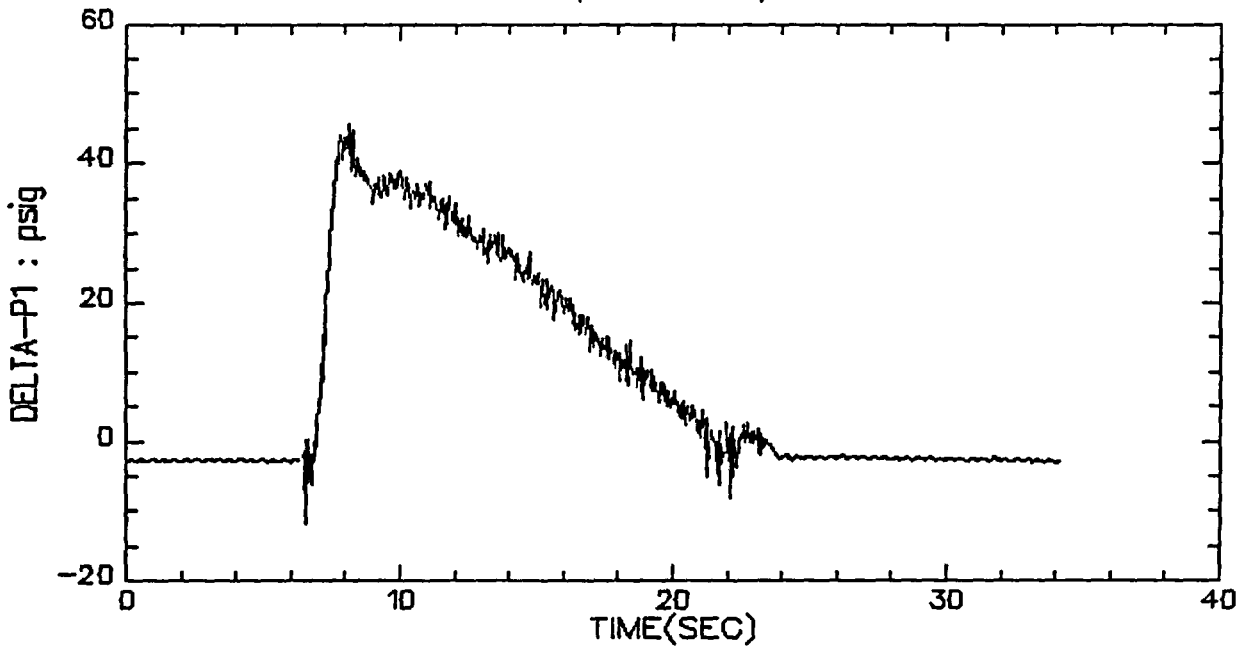

VALVE A, TEST 4, STEP 7

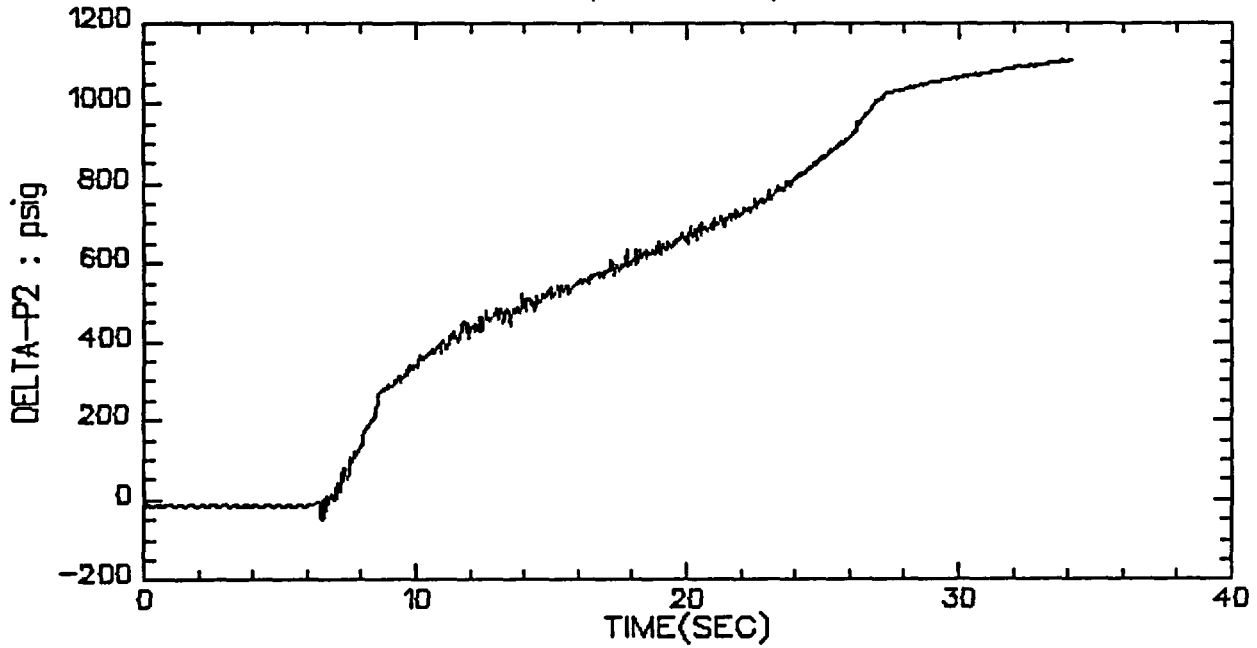

VALVE A, TEST 4, STEP 7

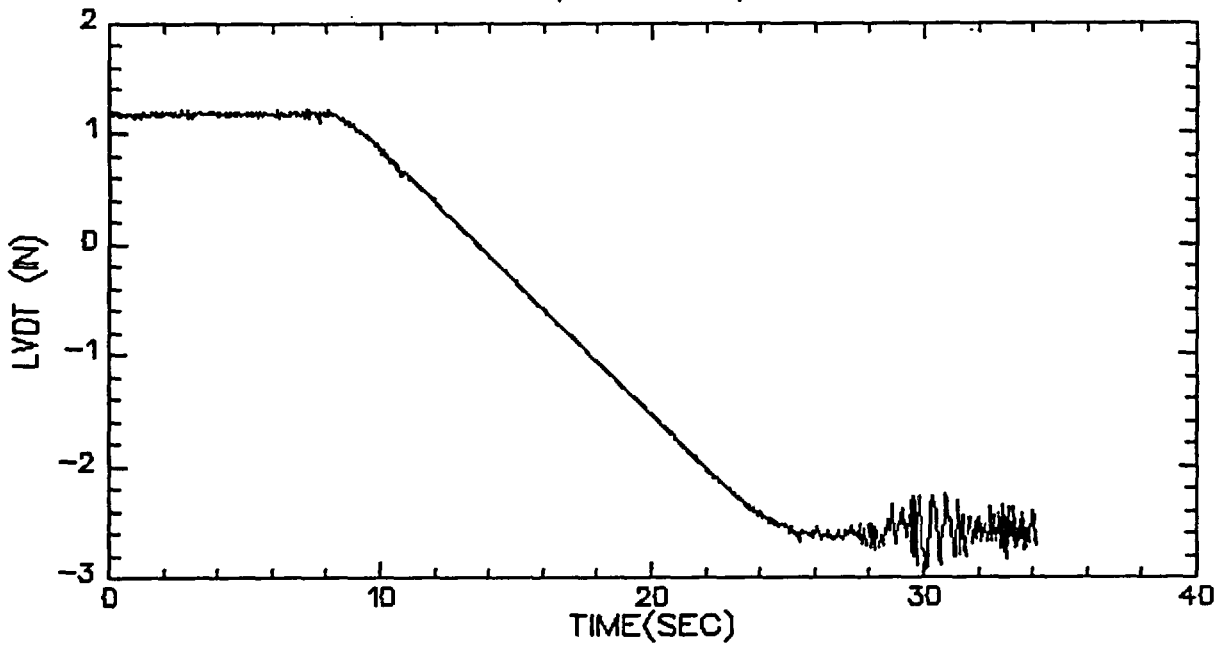

VALVE A, TEST 4, STEP 7

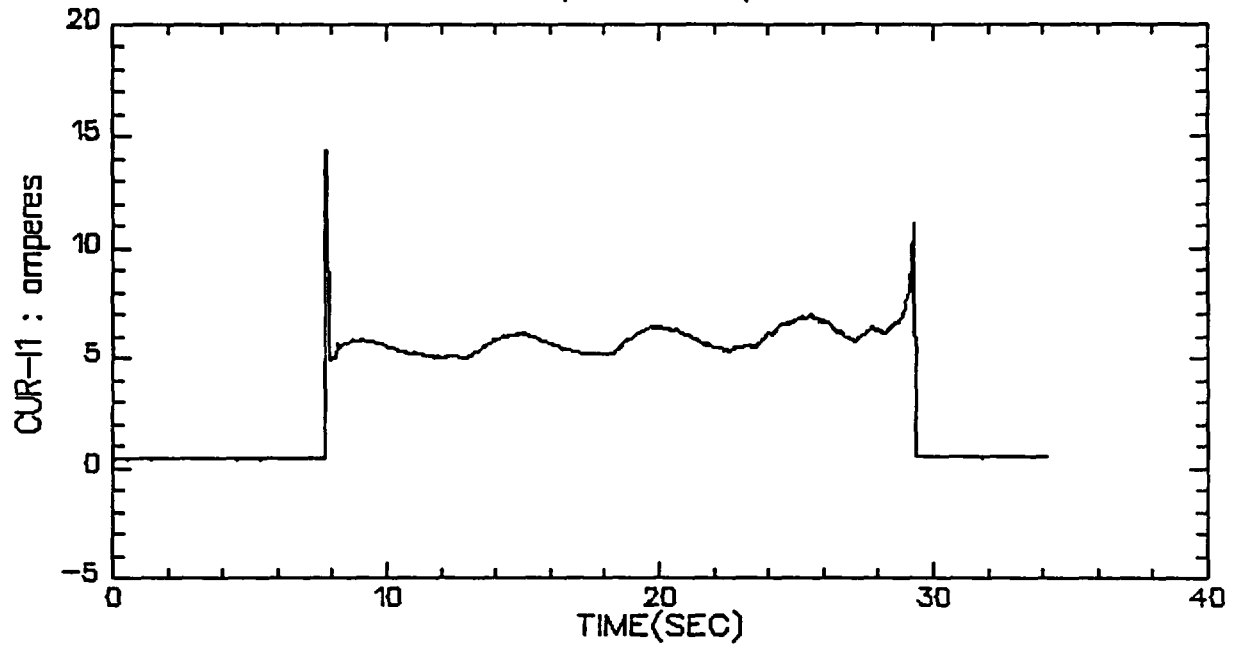

VALVE A, TEST 4, STEP 7

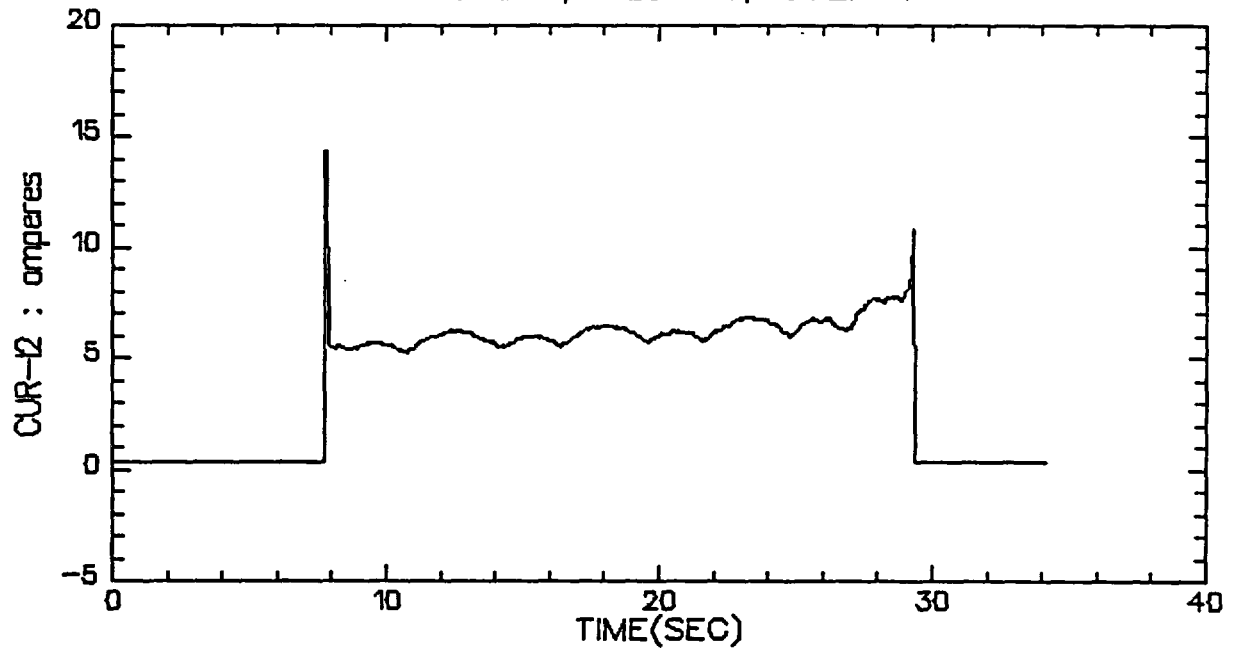

VALVE A, TEST 4, STEP 7

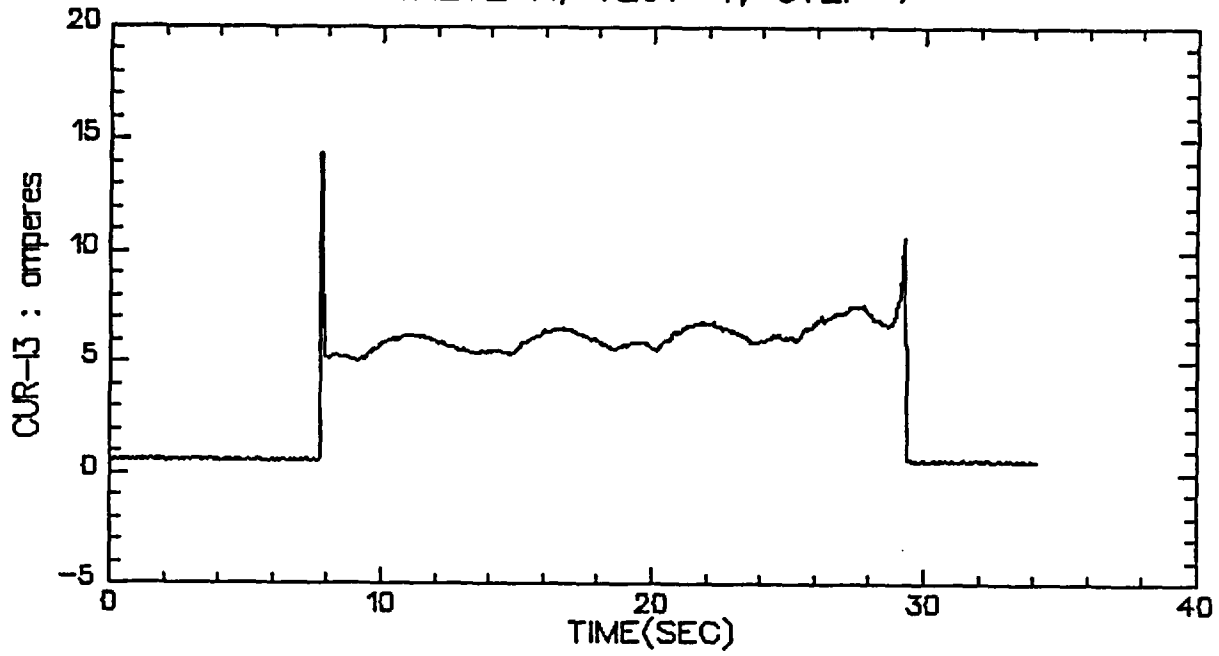

VALVE A, TEST 4, STEP 7

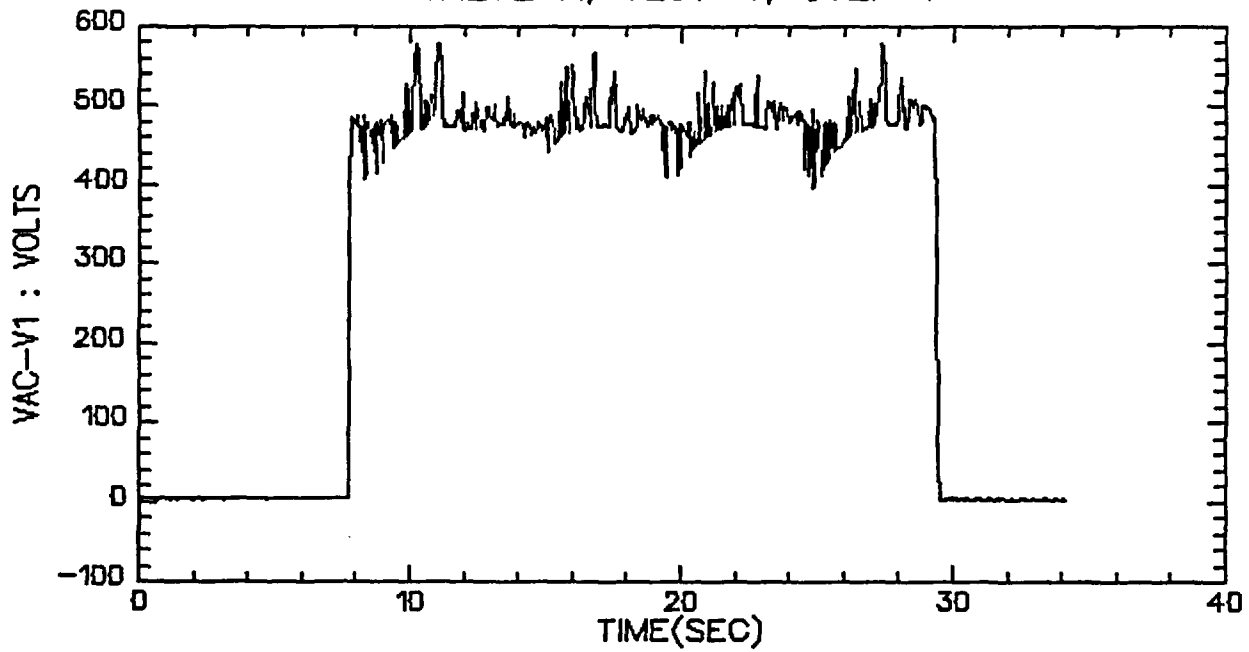

VALVE A, TEST 4, STEP 7

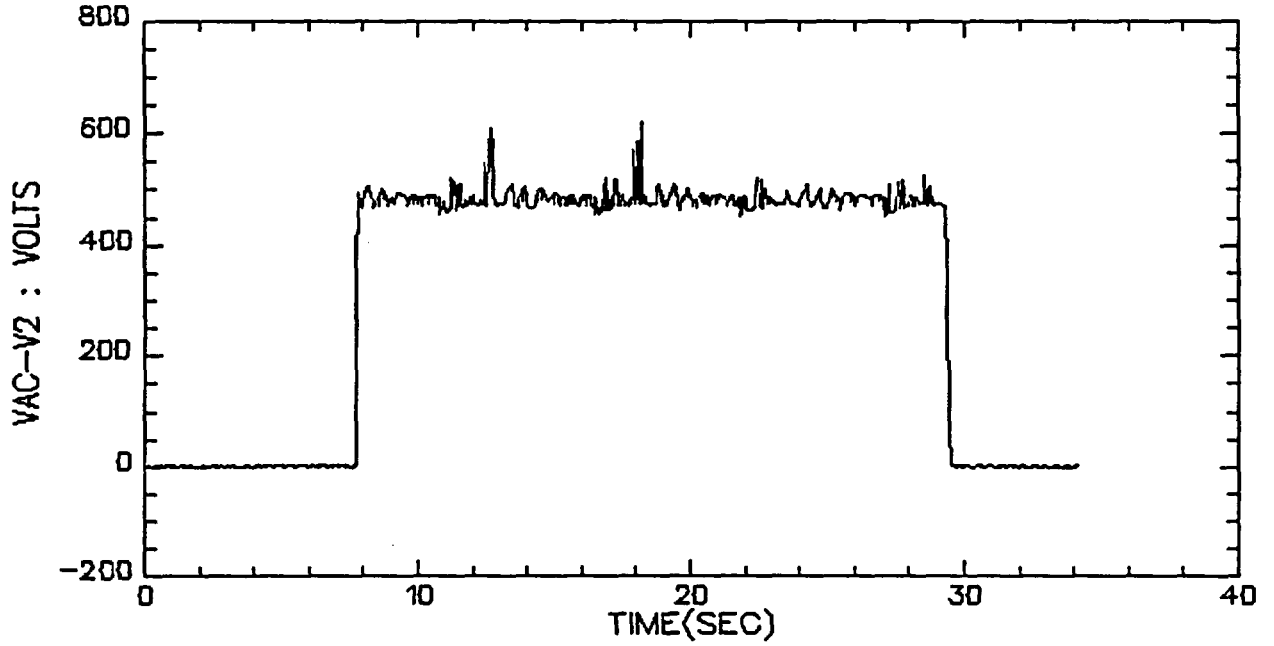

VALVE A, TEST 4, STEP 7

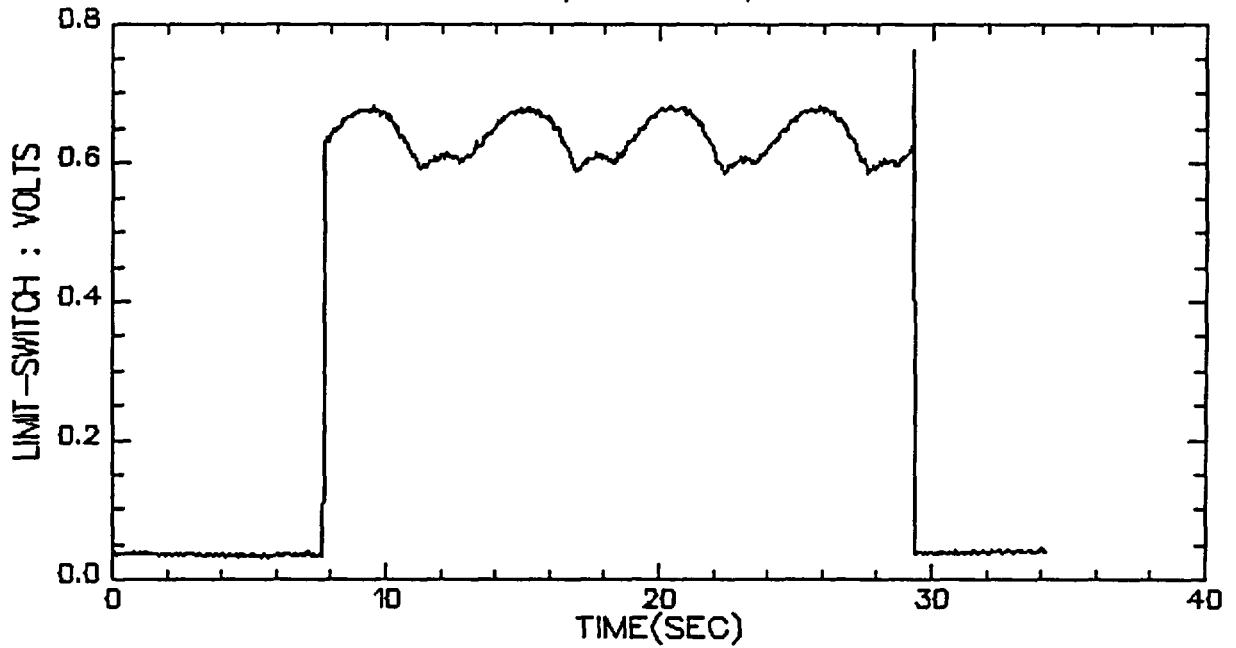

VALVE A, TEST 4, STEP 7

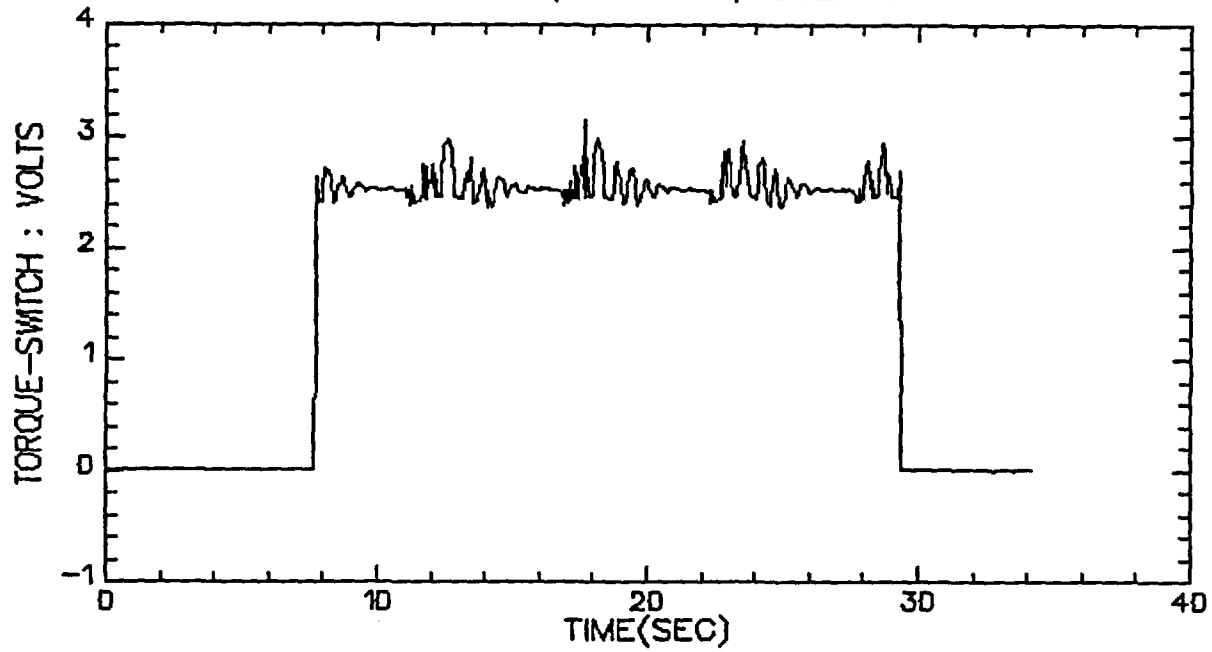

VALVE A, TEST 4, STEP 7

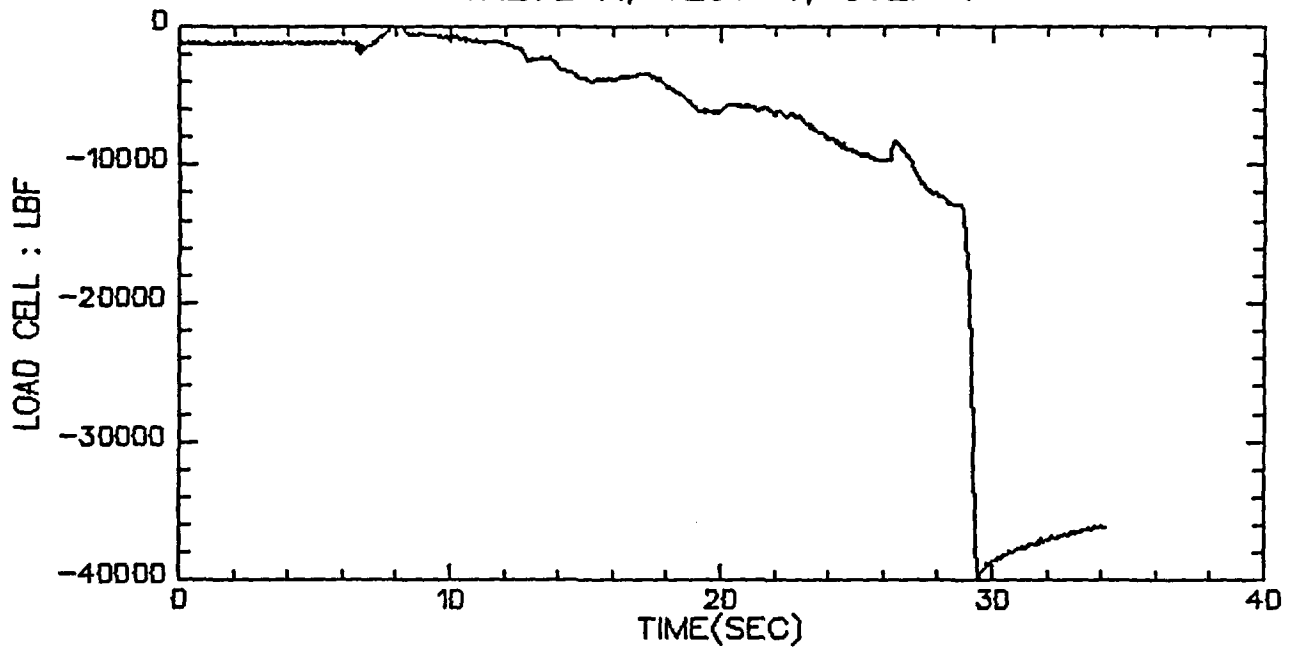

VALVE A, TEST 4 STEP 8&9

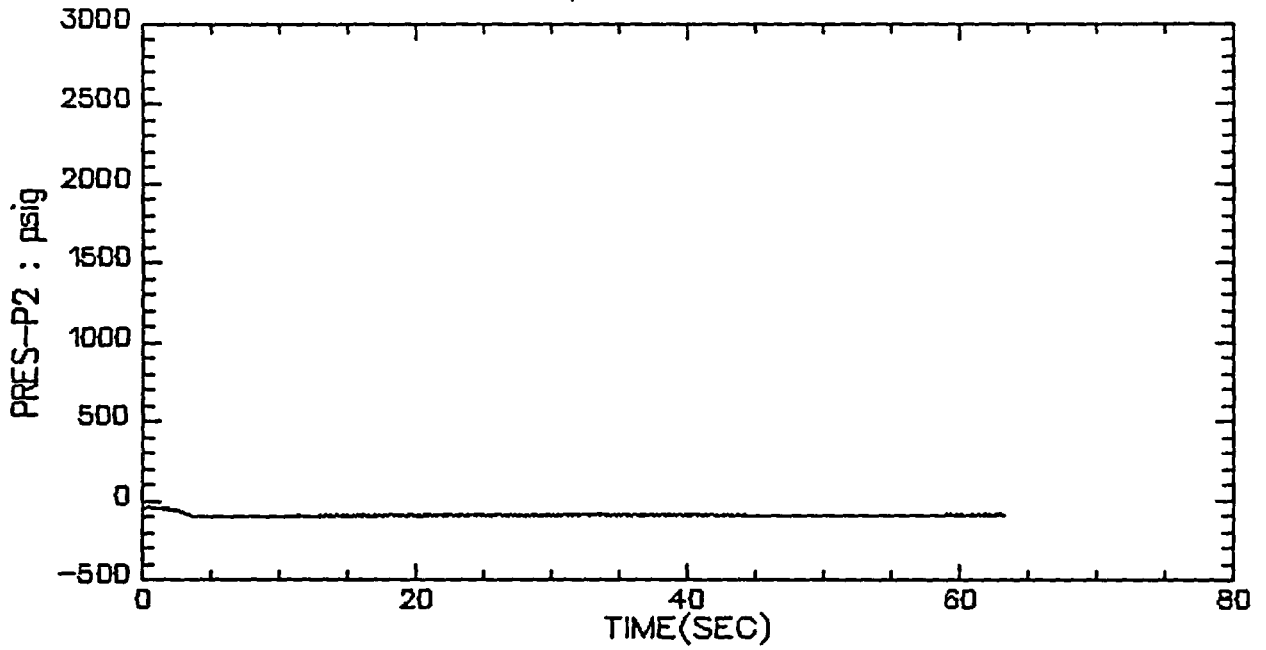

VALVE A, TEST 4 STEP 8&9

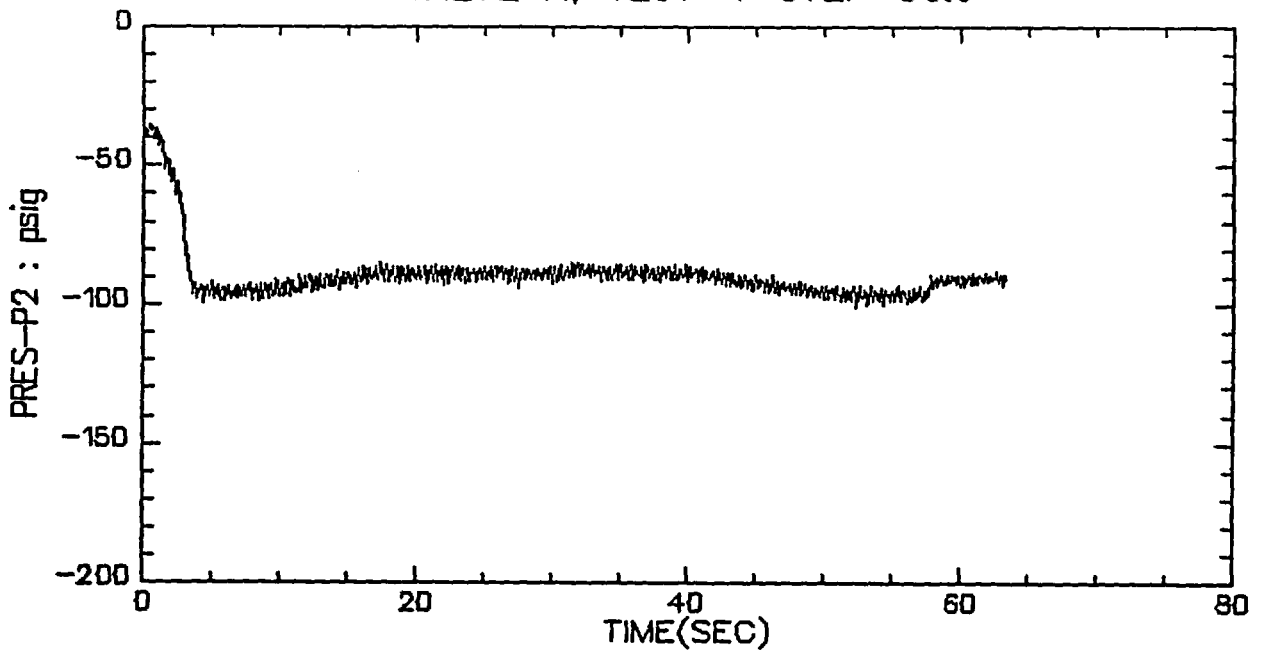

VALVE A, TEST 4 STEP 8&9

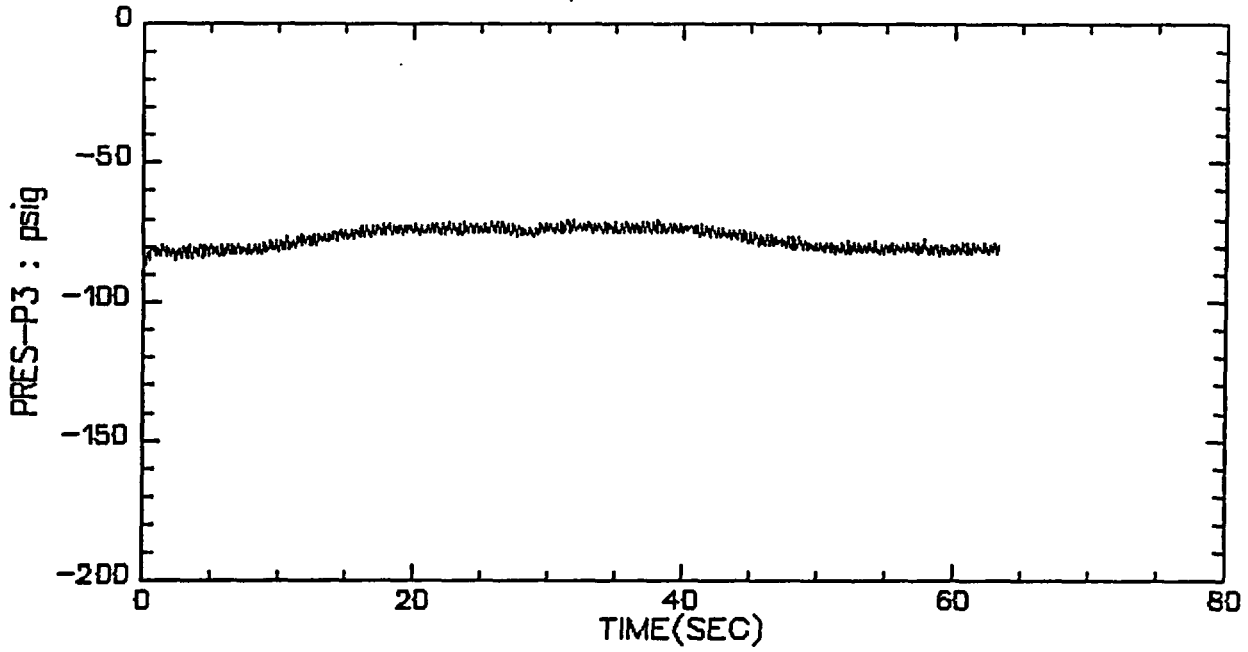

VALVE A, TEST 4 STEP 8&9

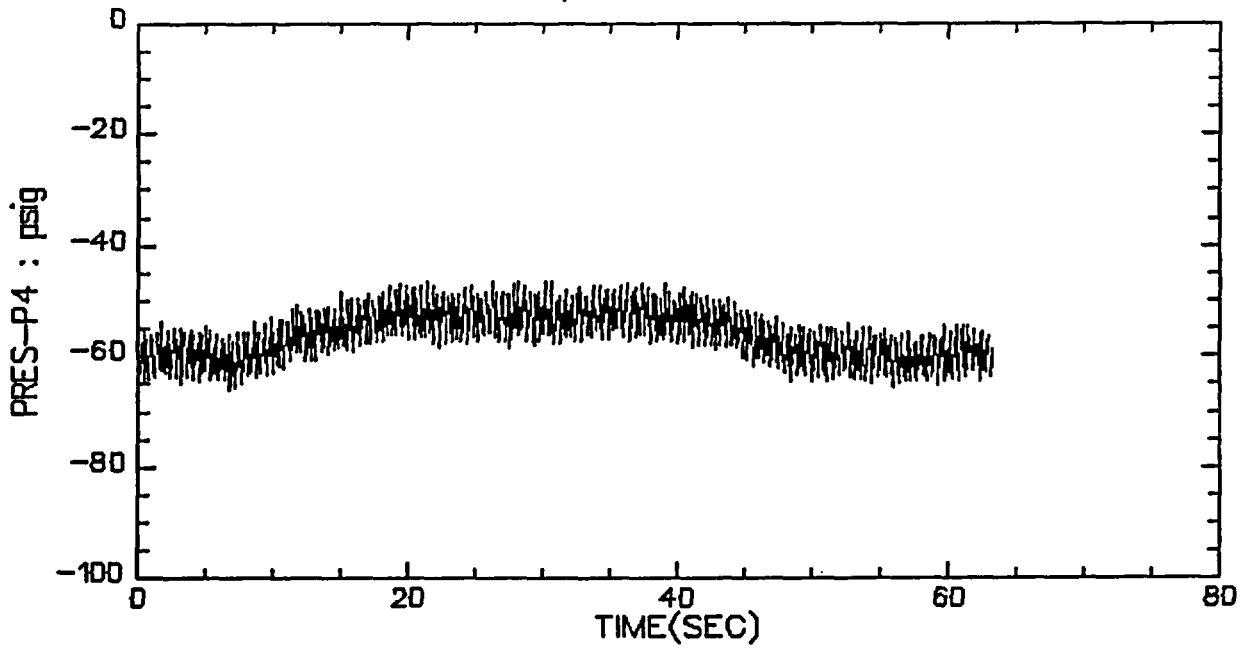

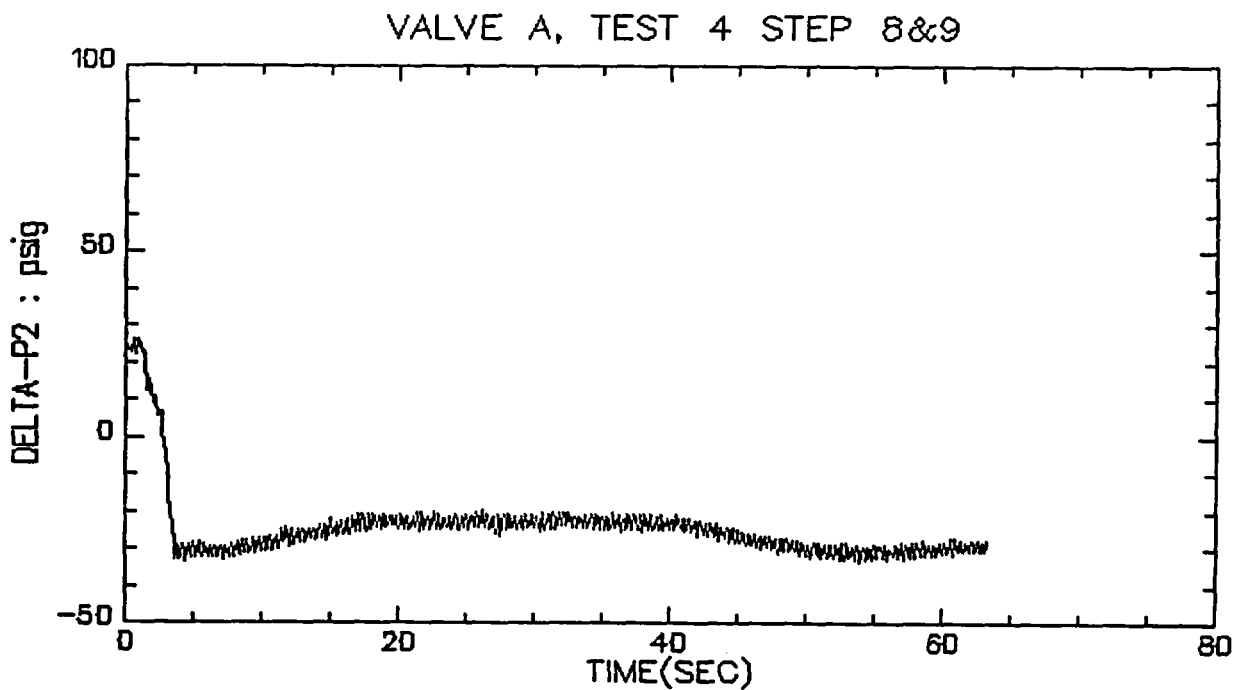
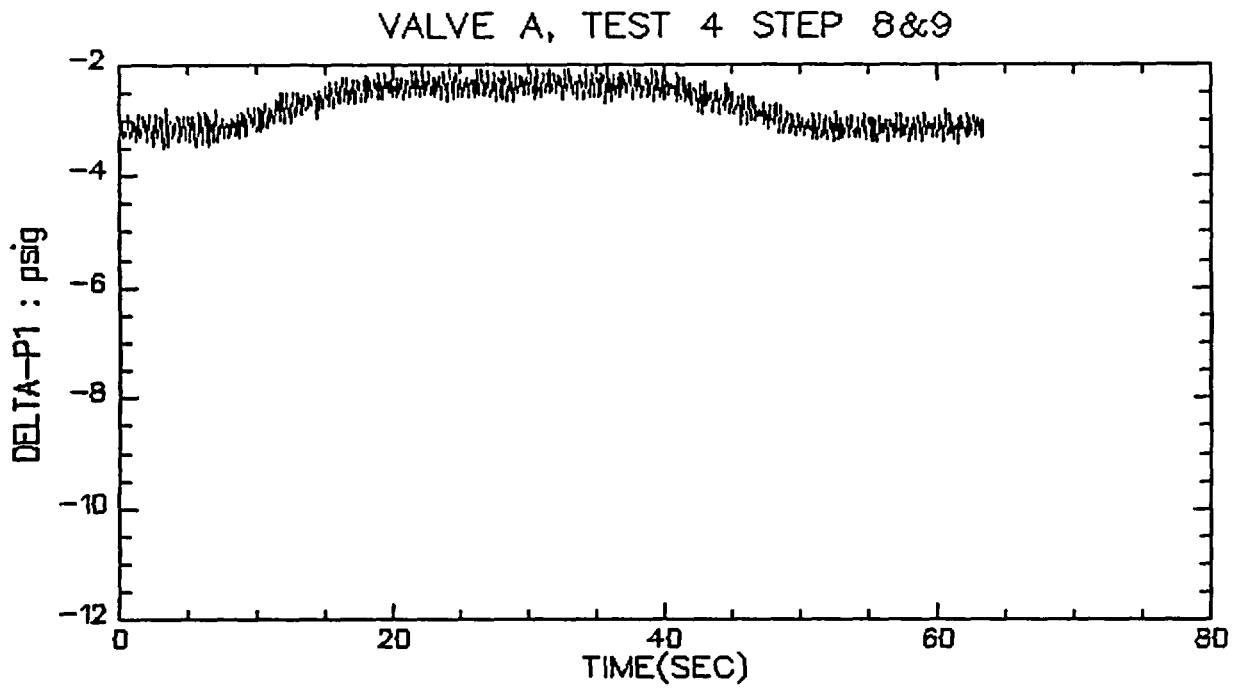

VALVE A, TEST 4 STEP 8&9

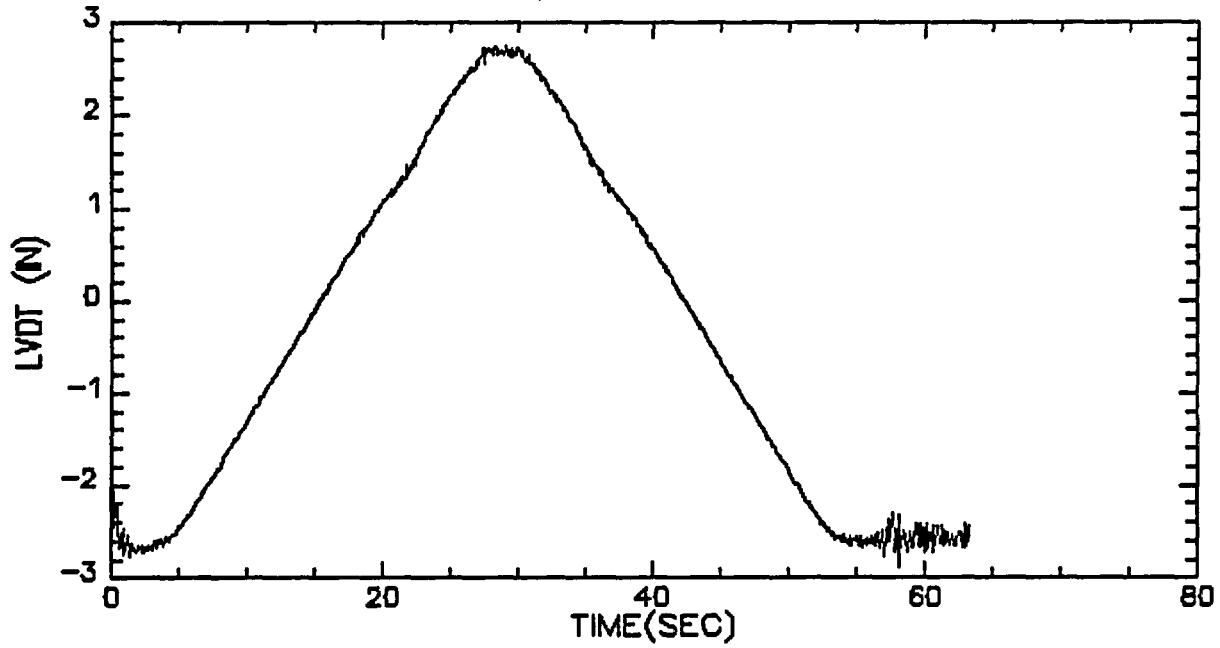

VALVE A, TEST 4 STEP 8&9

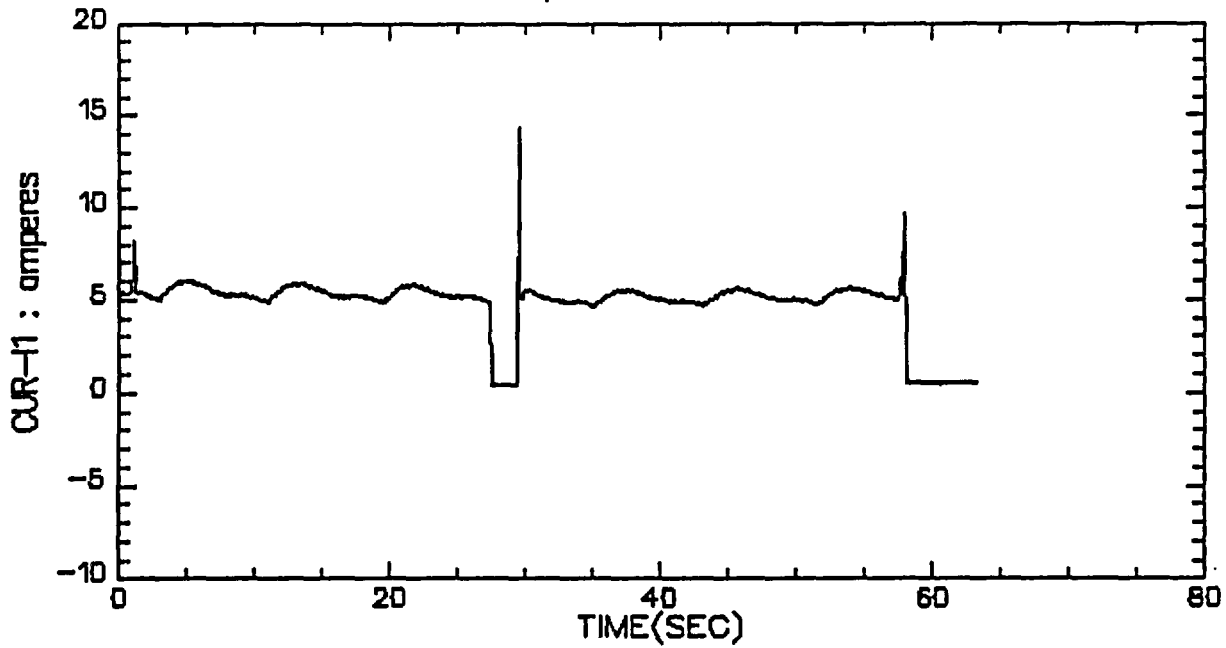

VALVE A, TEST 4 STEP 8&9

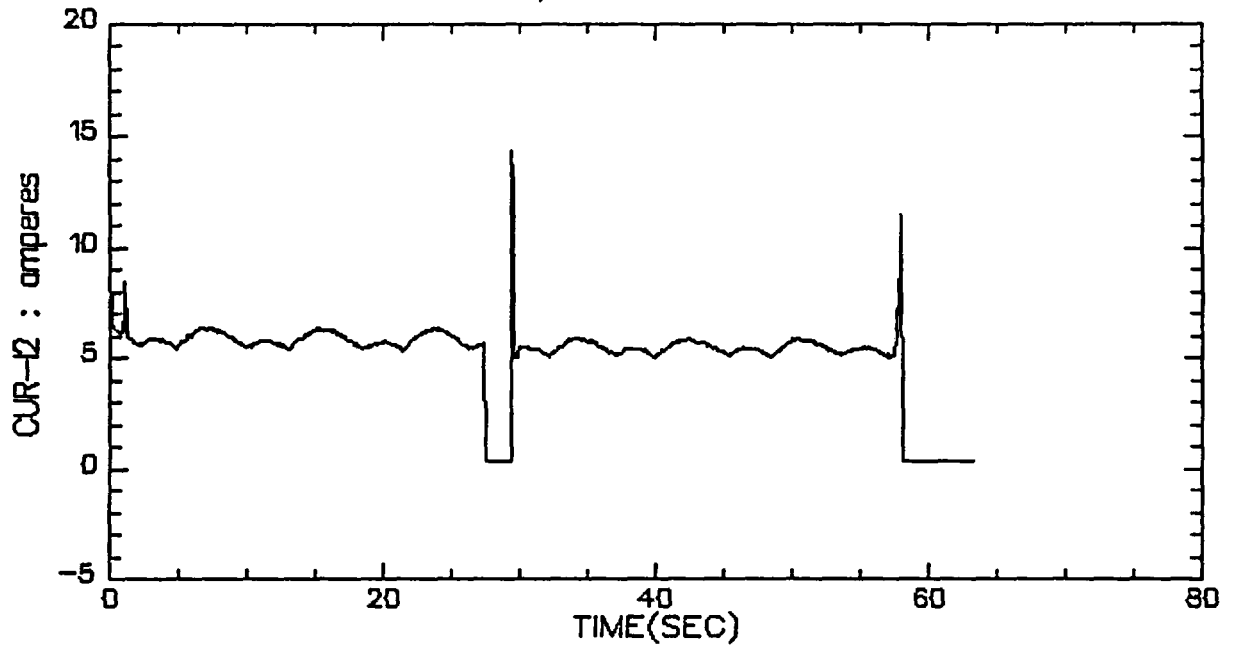

VALVE A, TEST 4 STEP 8&9

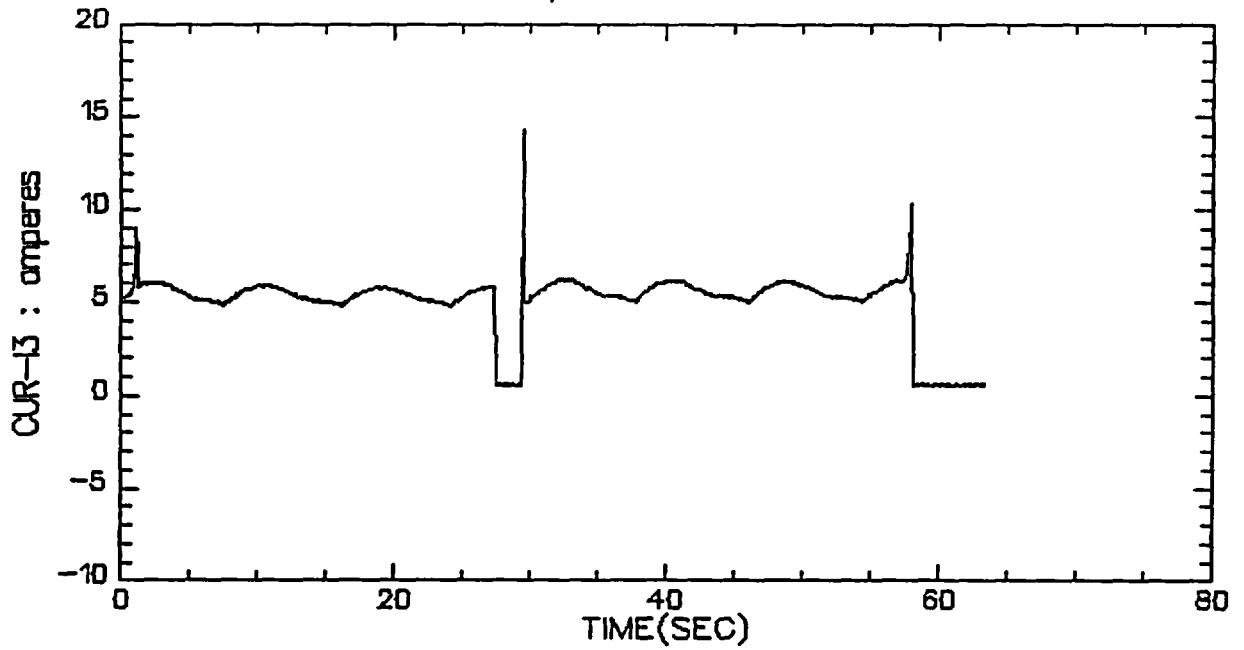

VALVE A, TEST 4 STEP 8&9

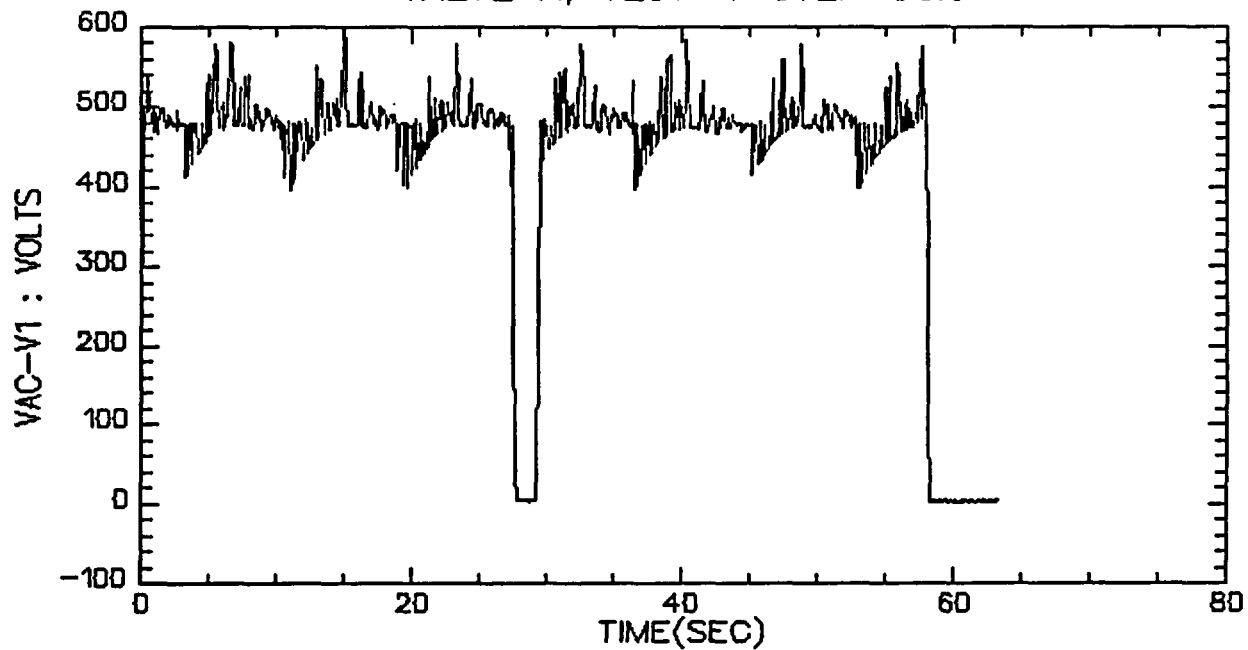

VALVE A, TEST 4 STEP 8&9

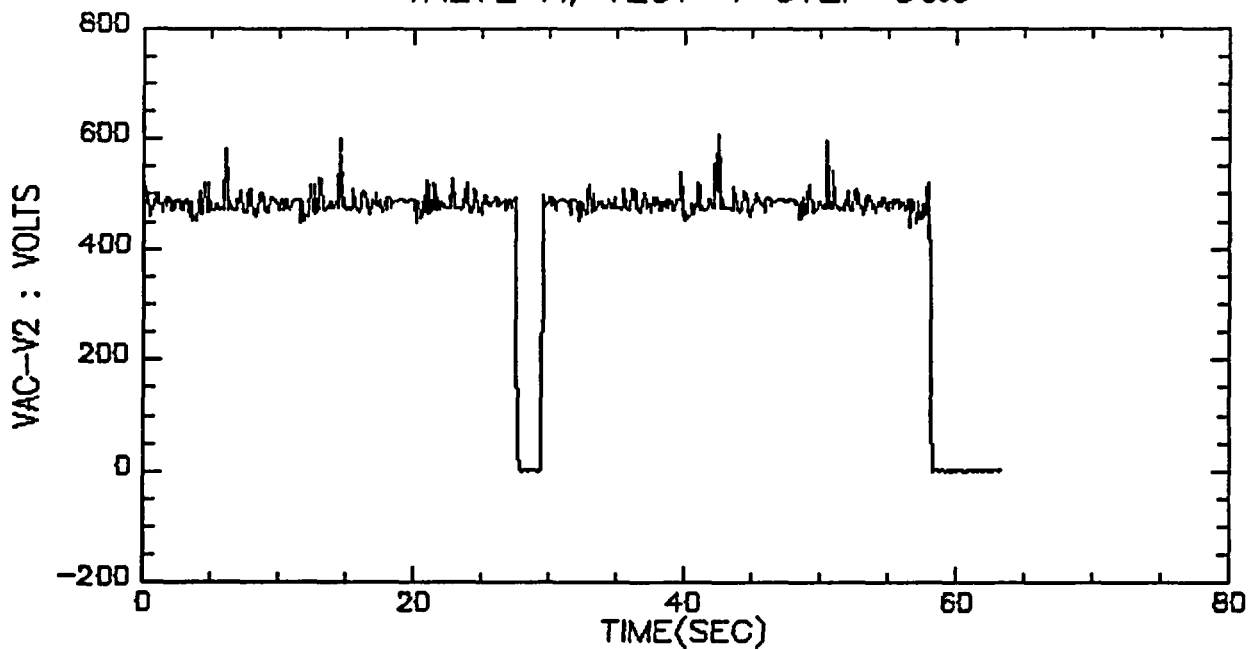

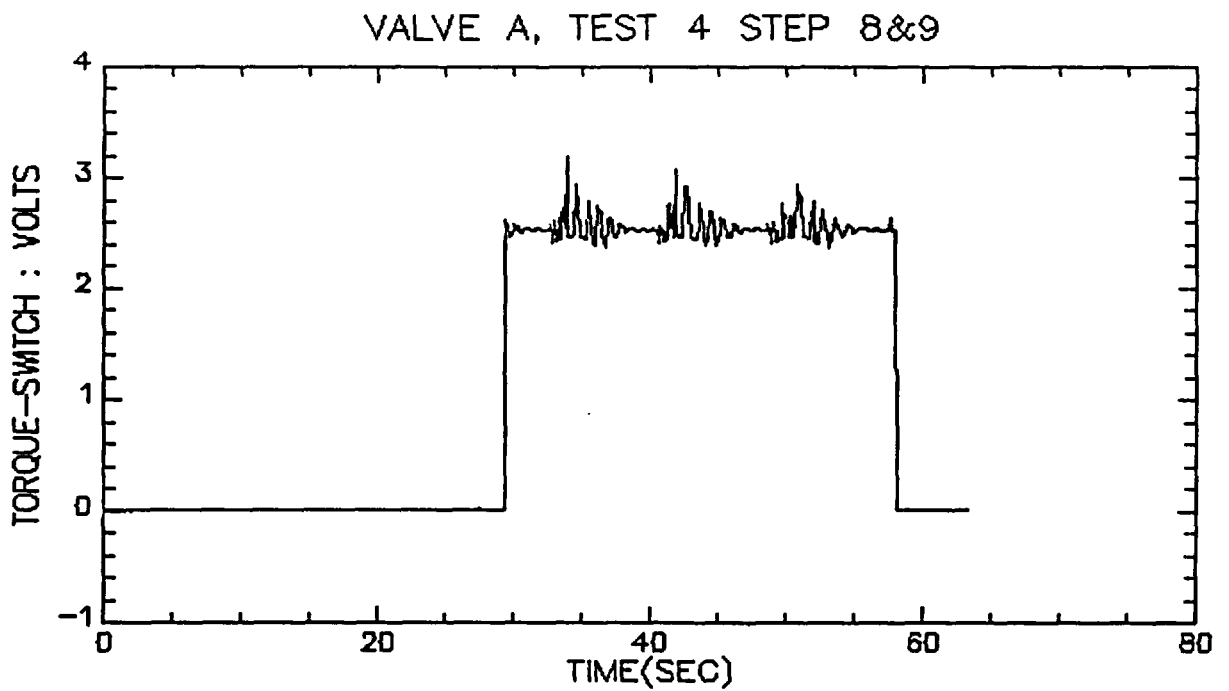
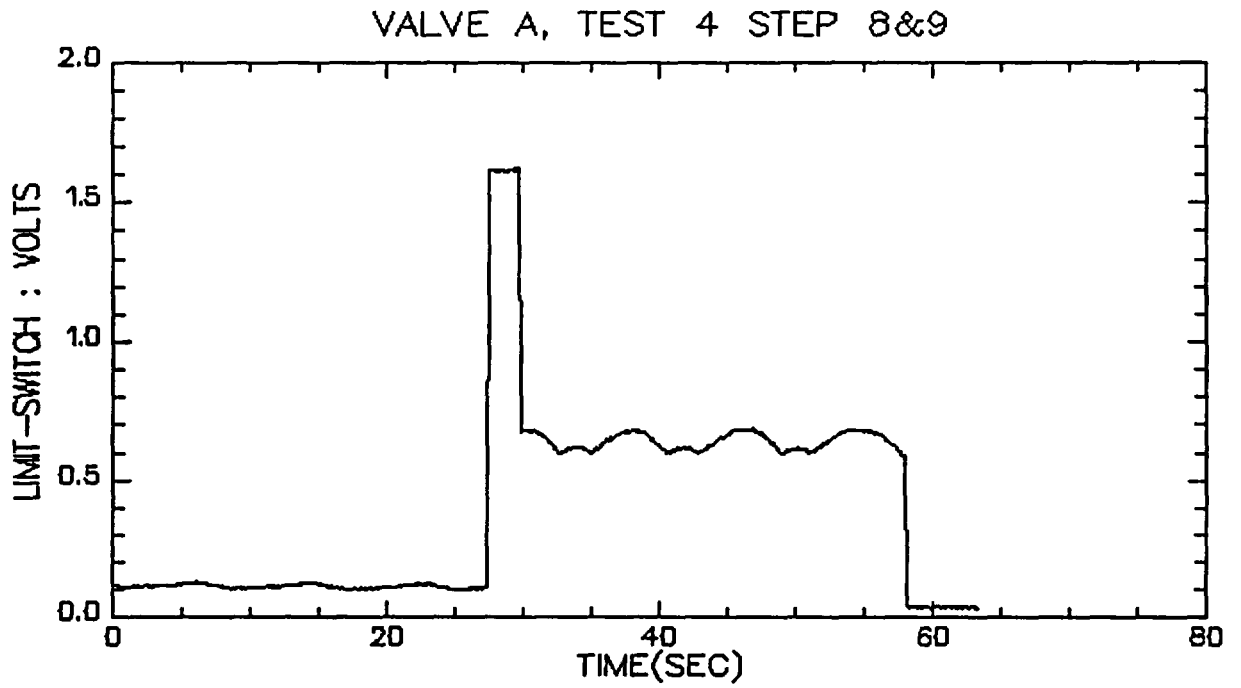

VALVE A, TEST 5, STEP 1

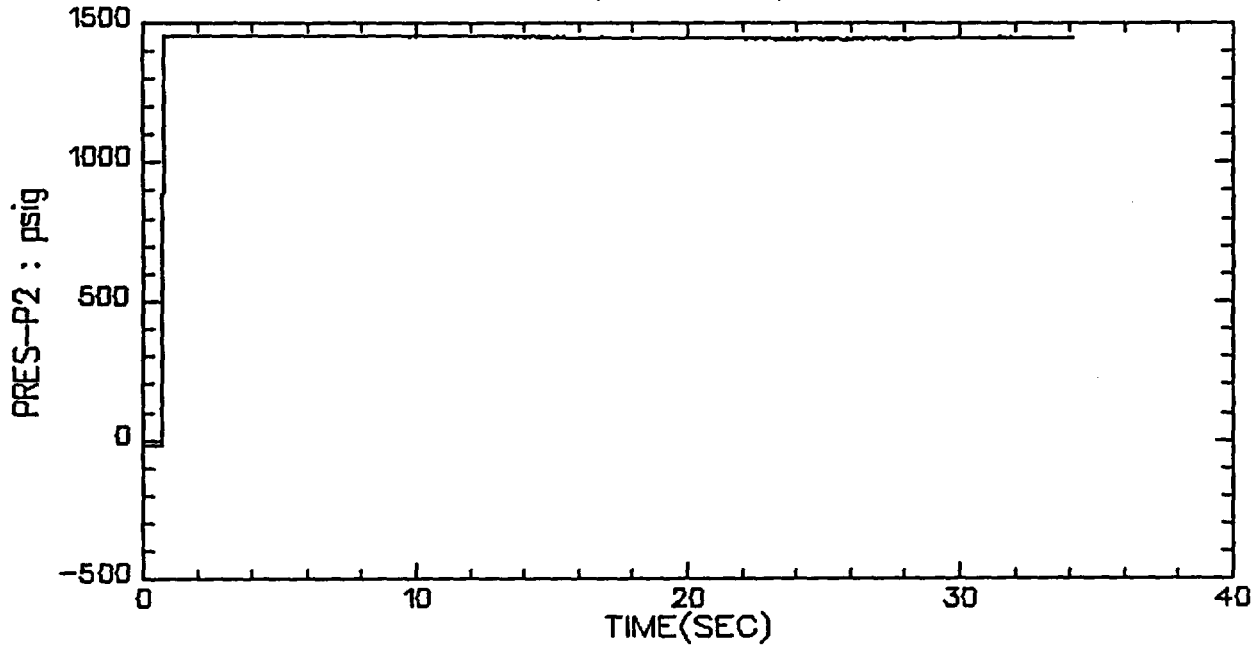

VALVE A, TEST 5, STEP 1

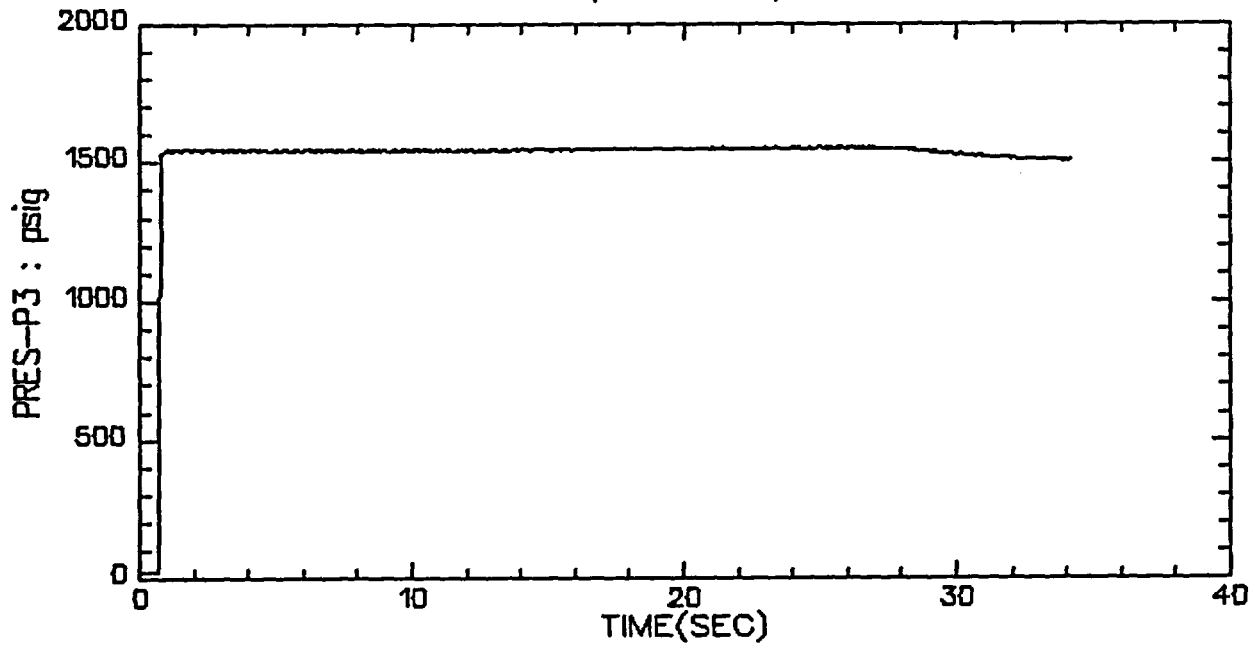

VALVE A, TEST 5, STEP 1

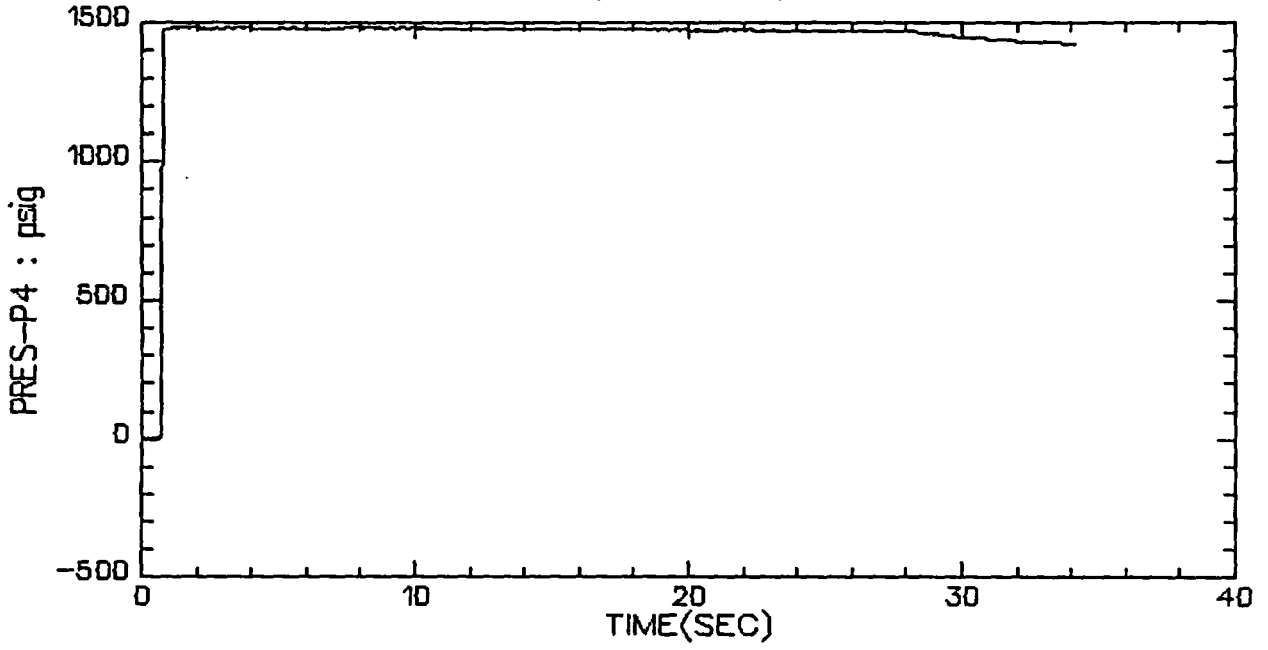

VALVE A, TEST 5, STEP 1

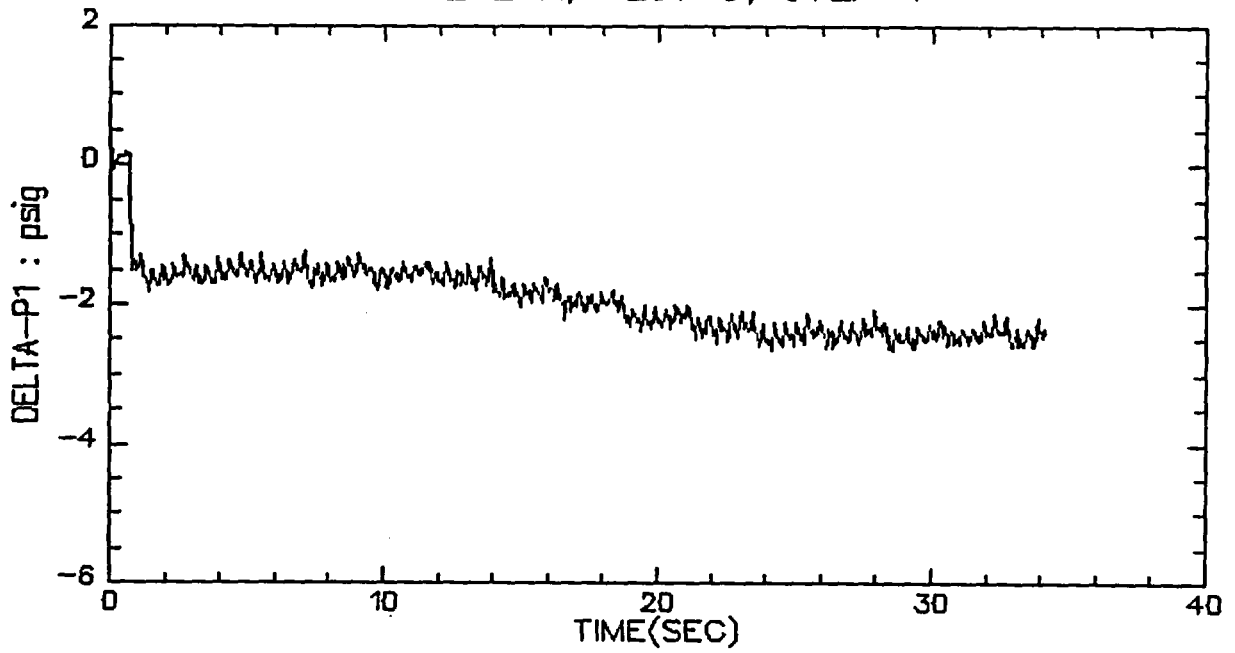

VALVE A, TEST 5, STEP 1

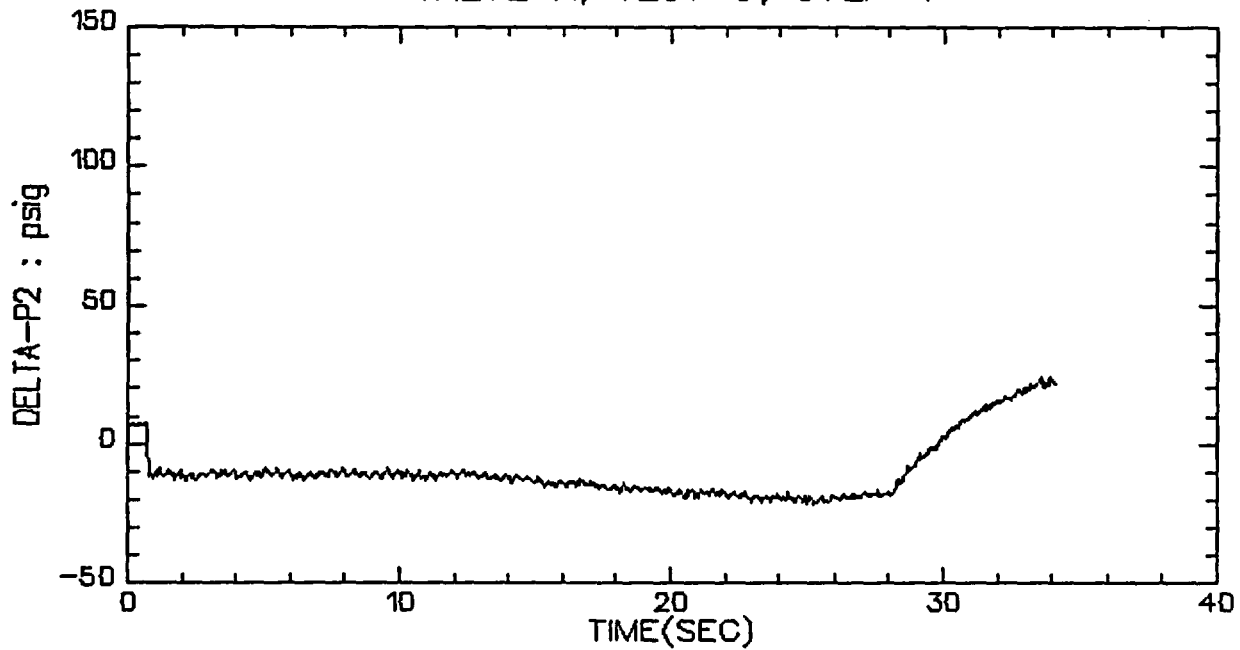

VALVE A, TEST 5, STEP 1

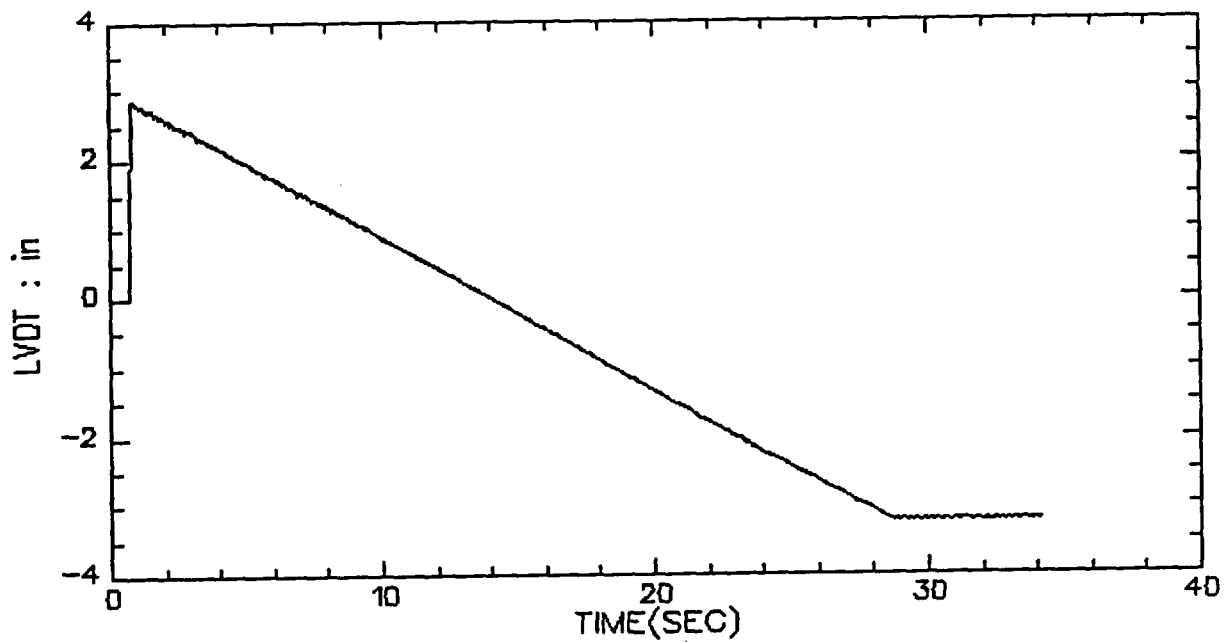

VALVE A, TEST 5, STEP 1

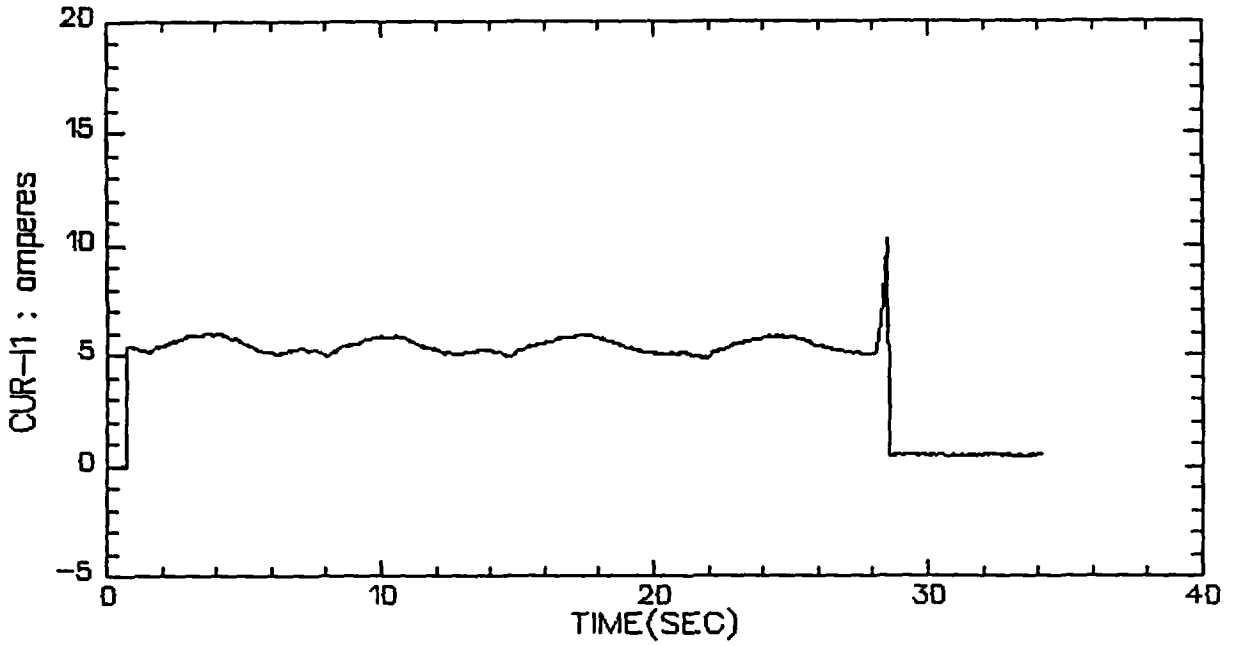

VALVE A, TEST 5, STEP 1

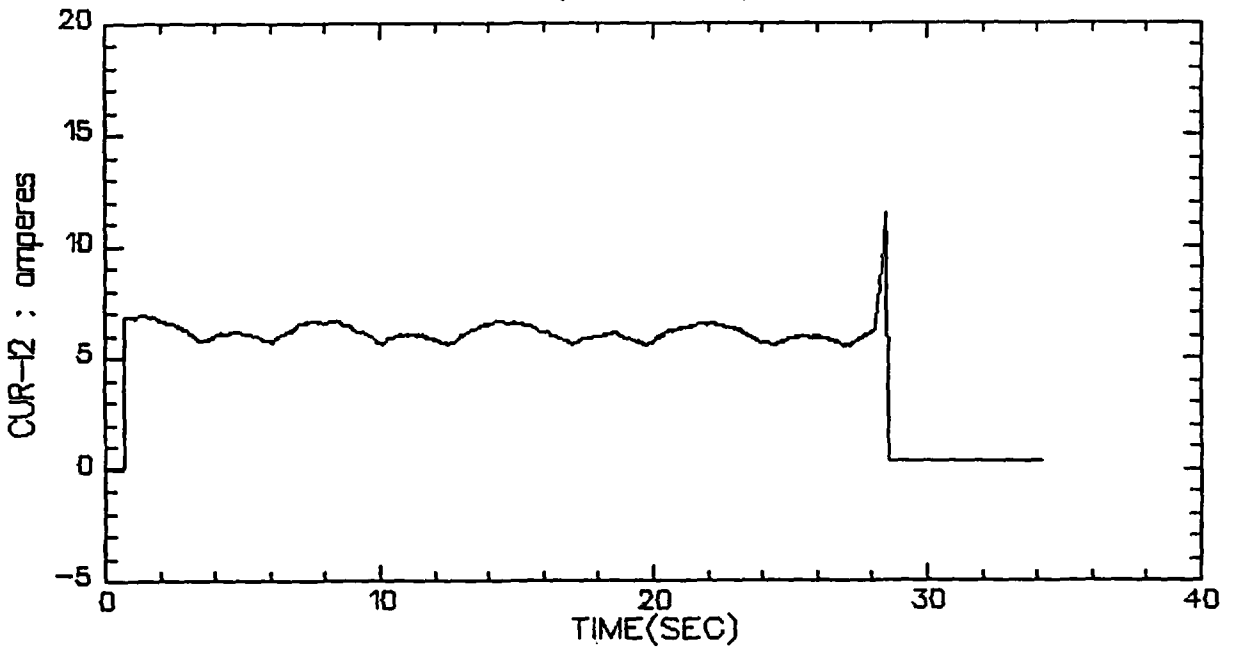

VALVE A, TEST 5, STEP 1

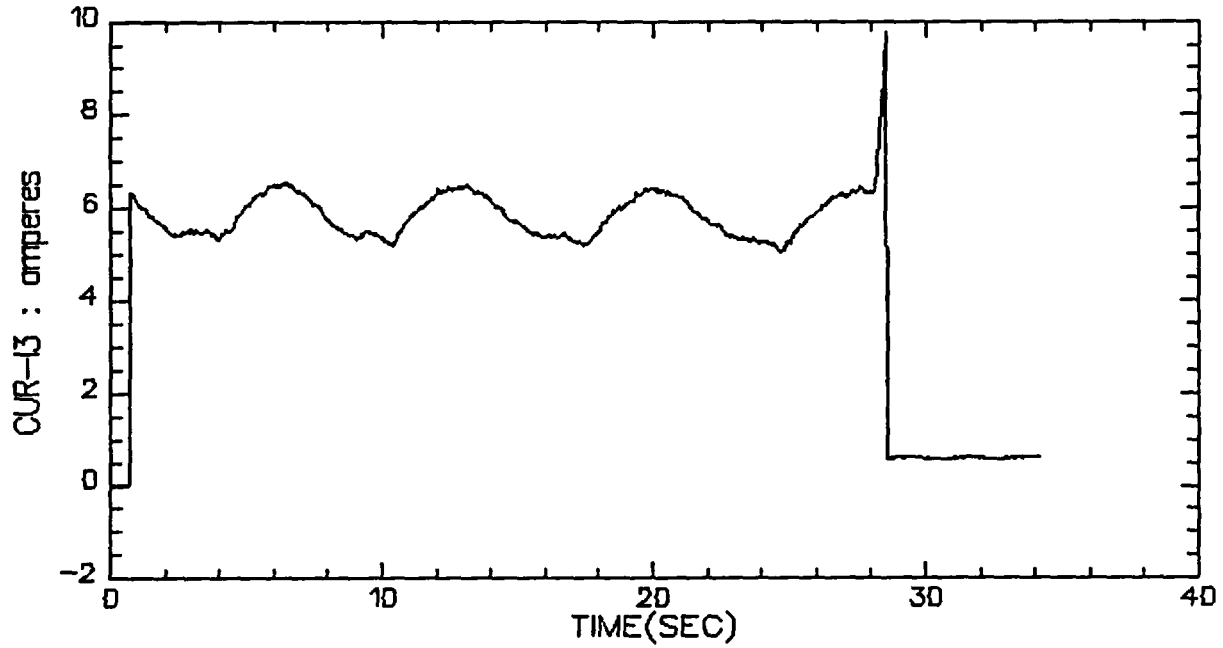

VALVE A, TEST 5, STEP 1

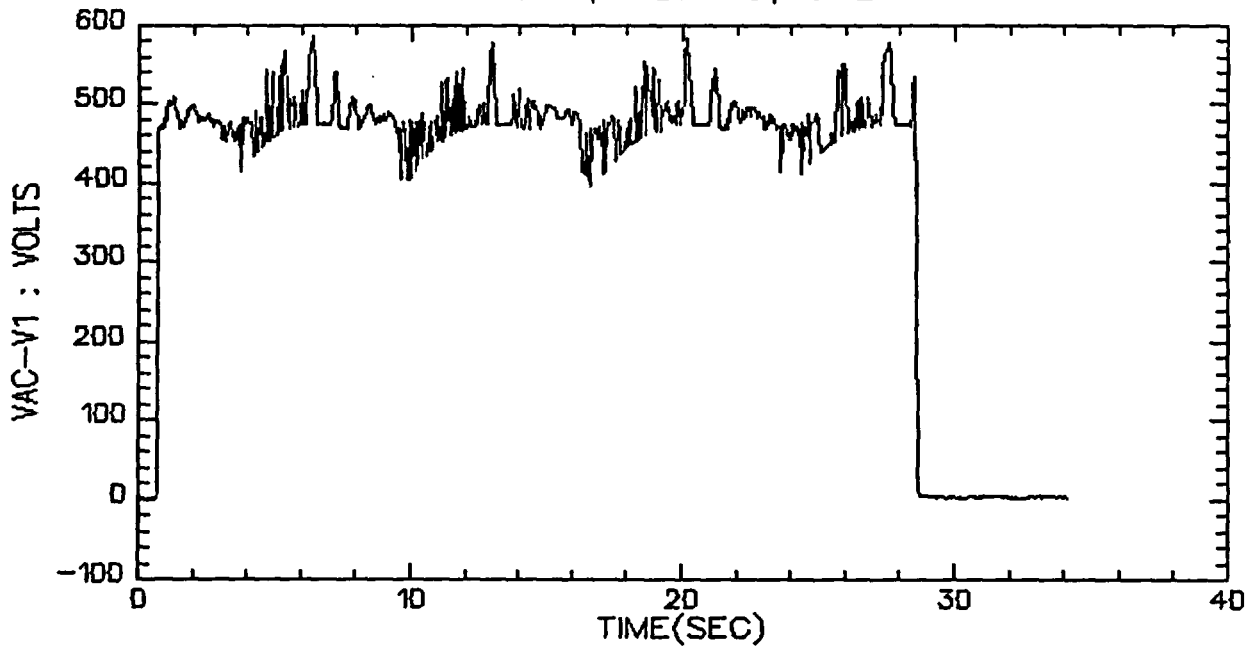

VALVE A, TEST 5, STEP 1

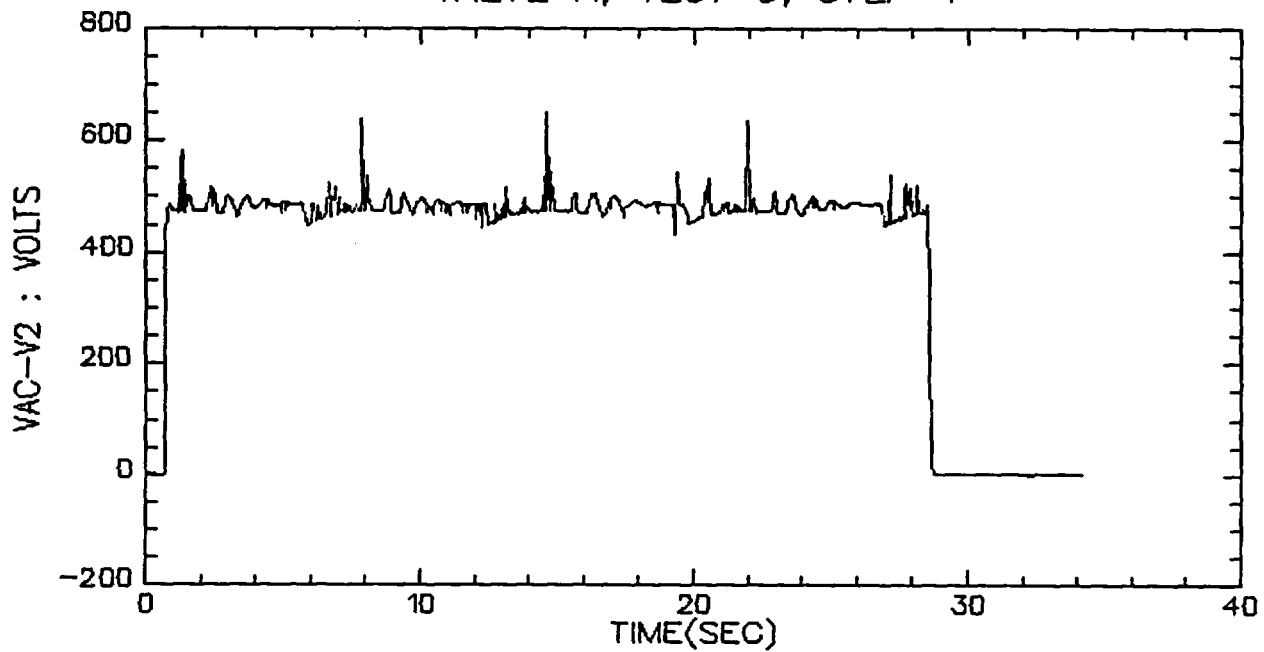

VALVE A, TEST 5, STEP 1

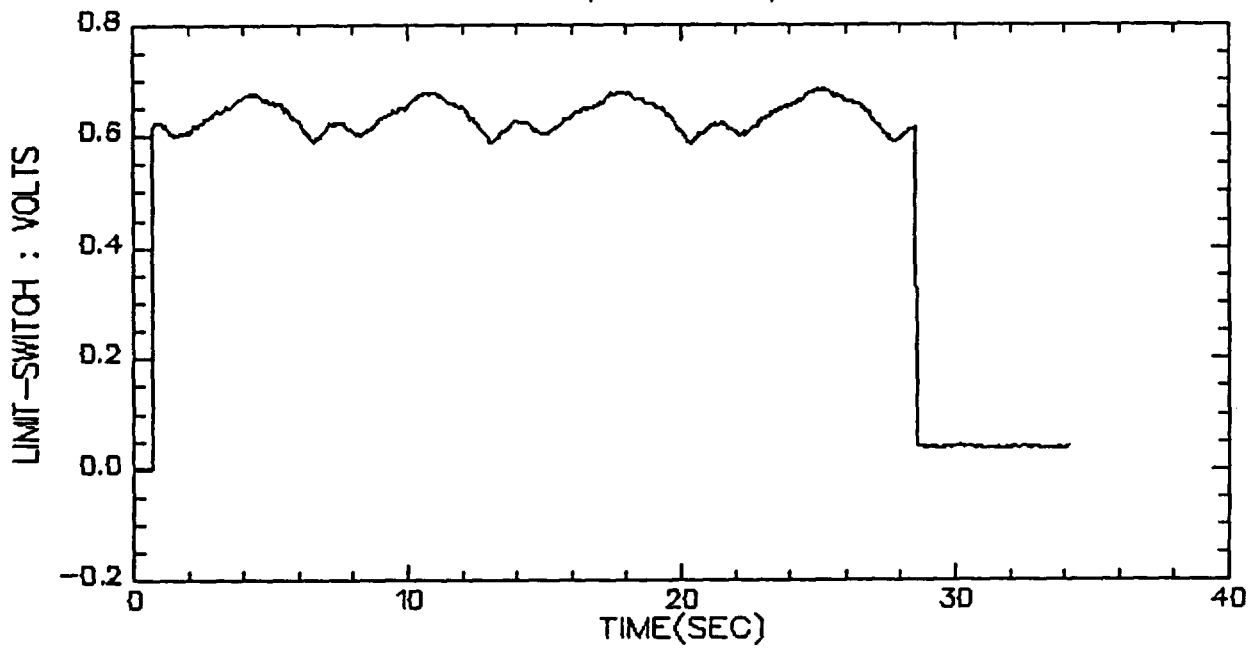

VALVE A, TEST 5, STEP 1

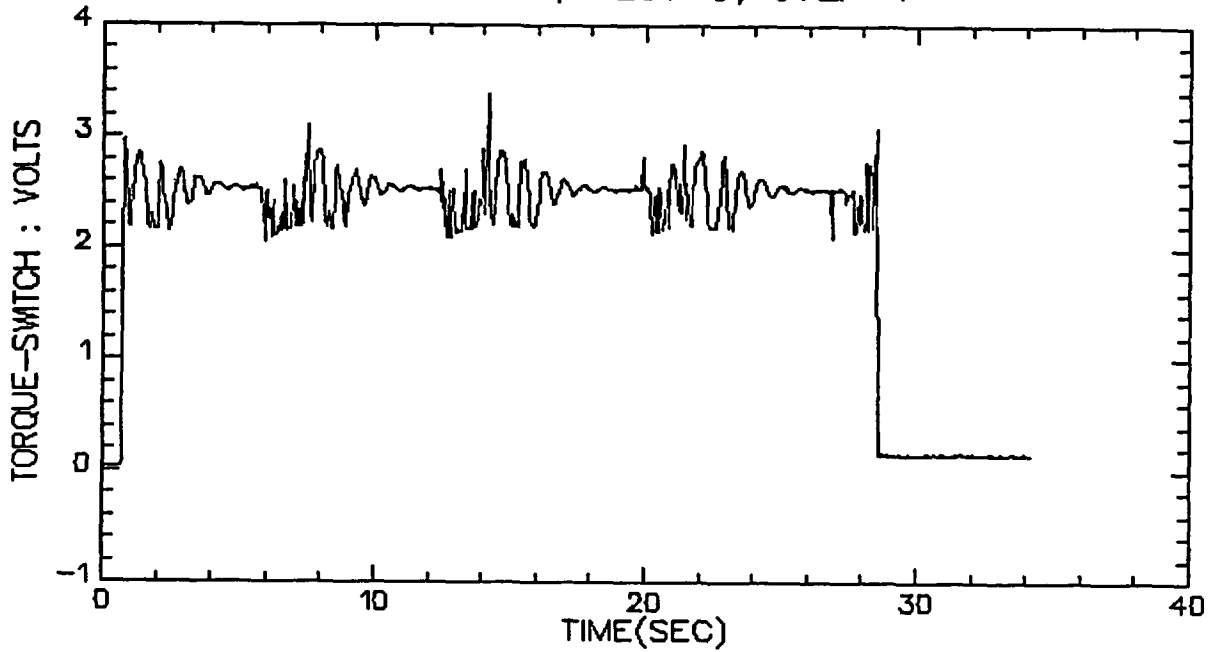

VALVE A, TEST 5, STEP 1

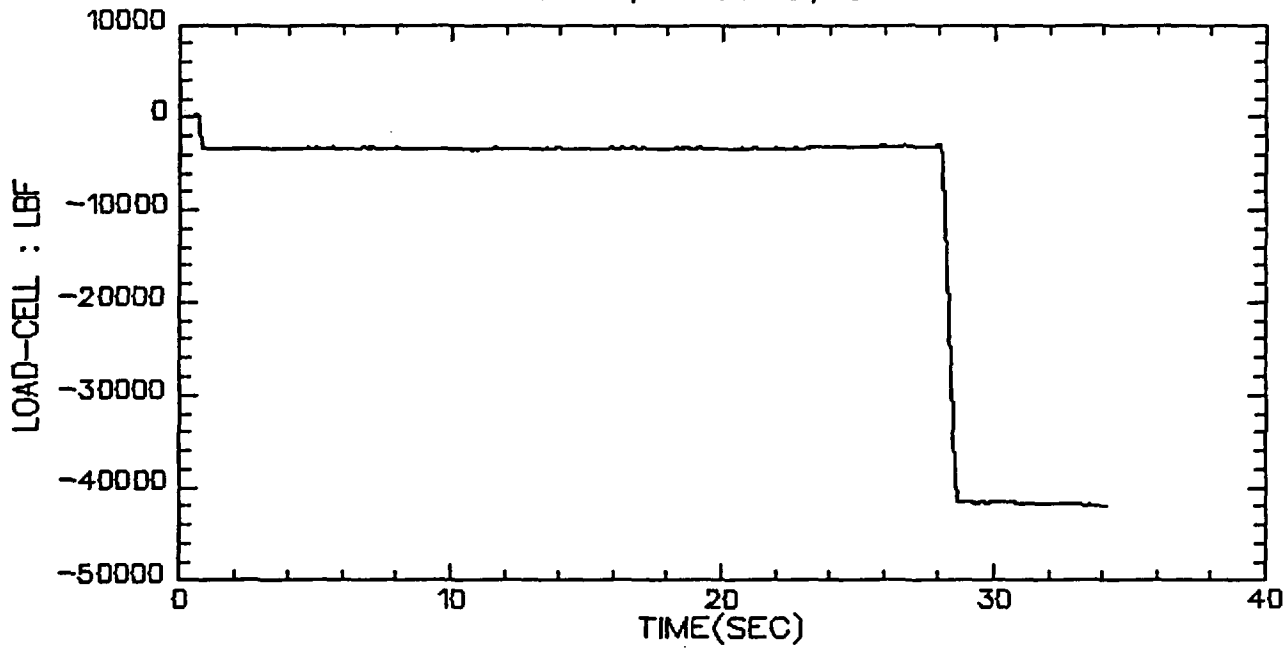

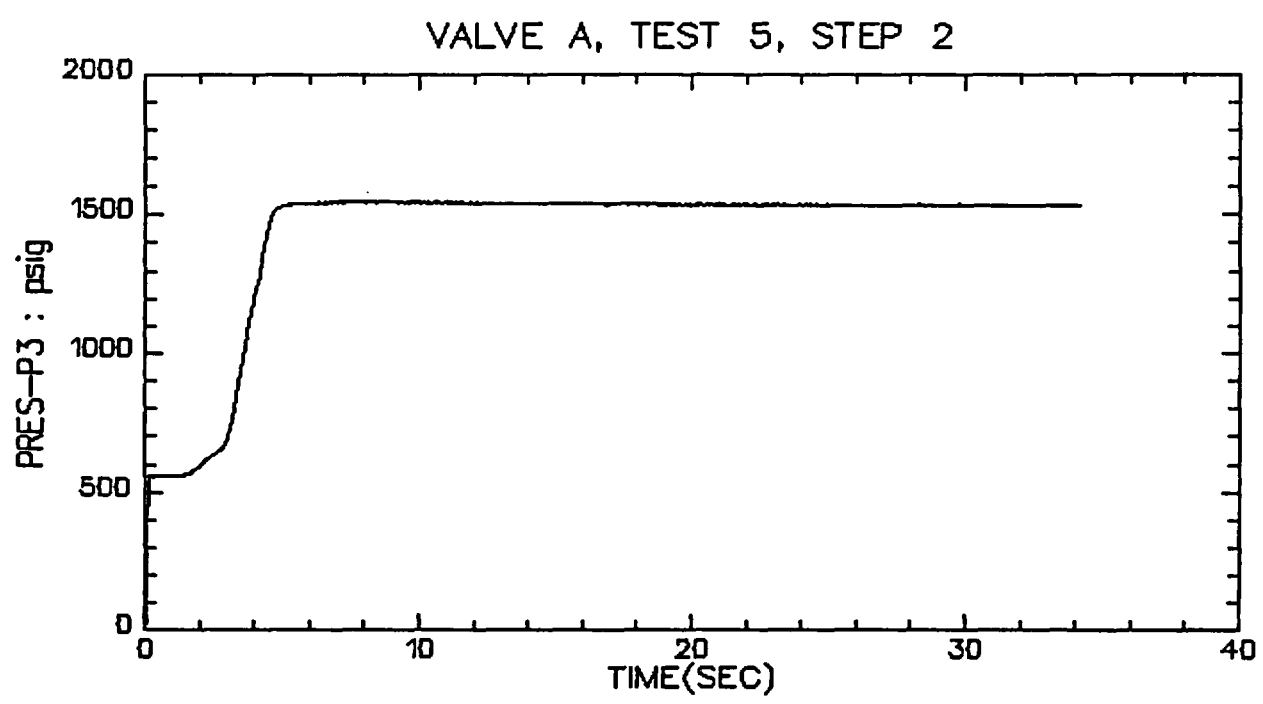
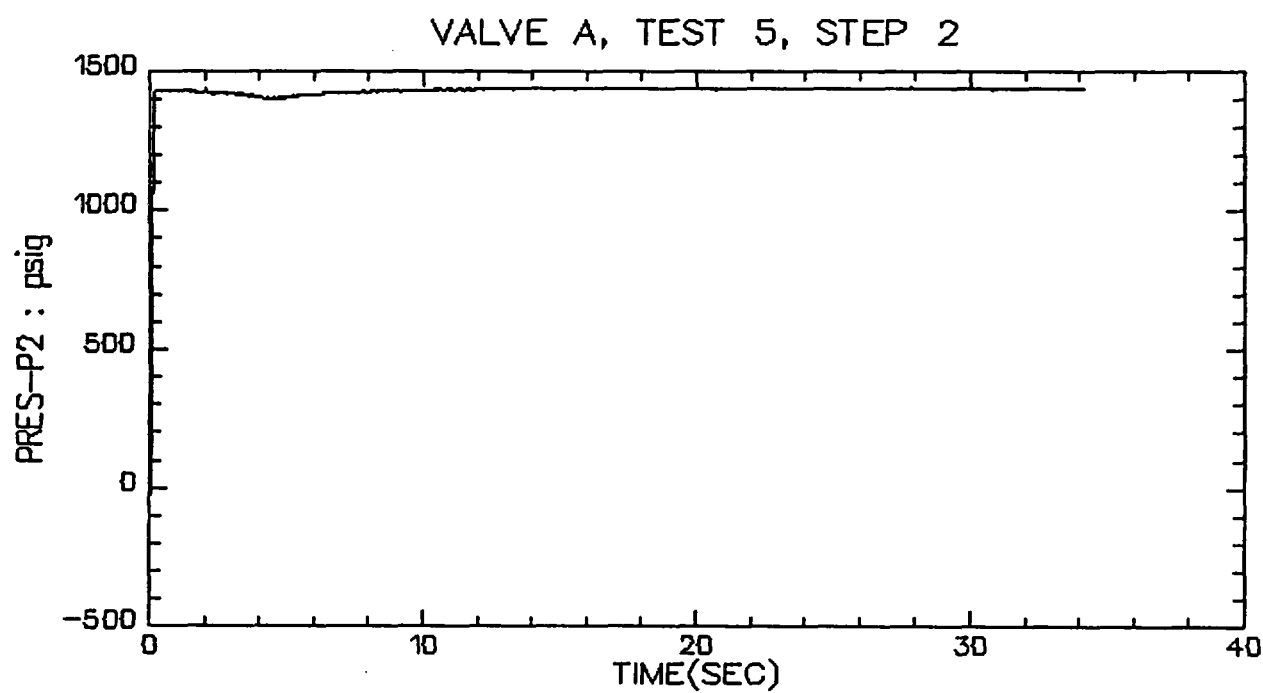

VALVE A, TEST 5, STEP 2

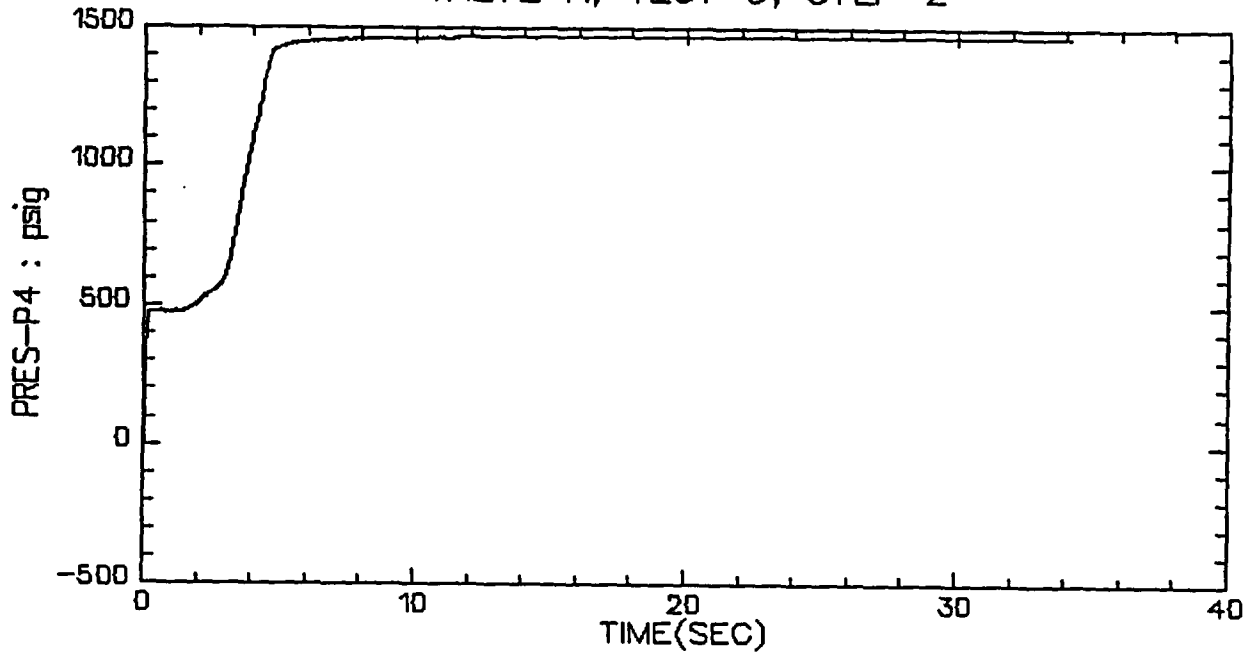

VALVE A, TEST 5, STEP 2

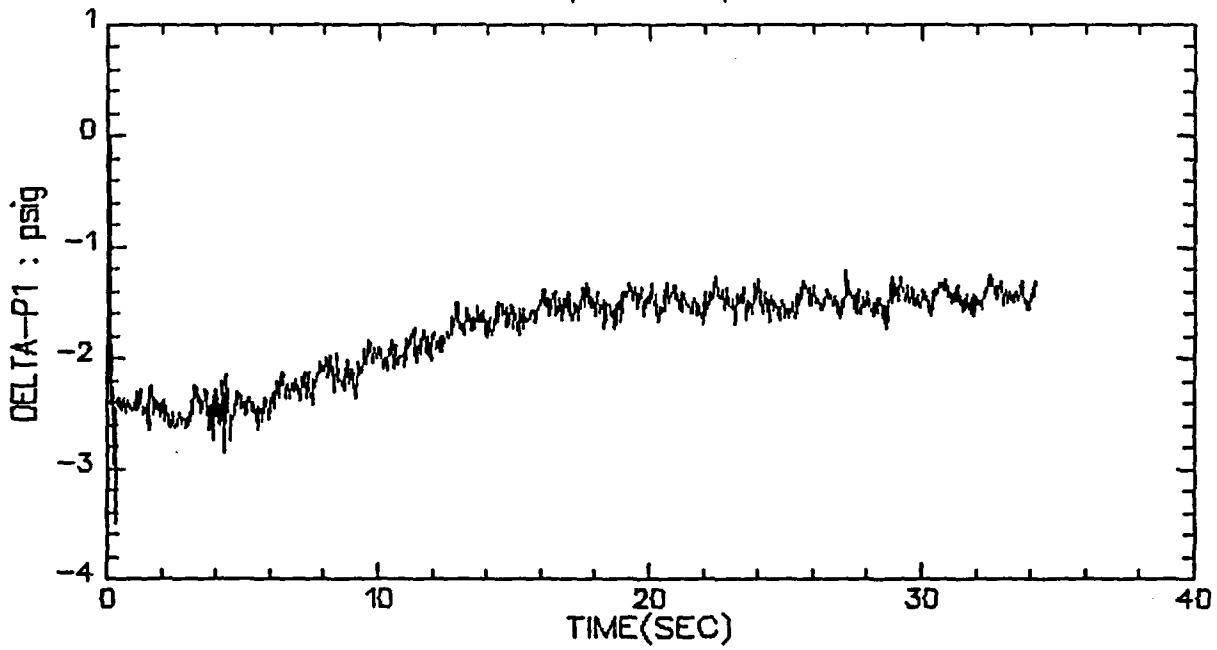

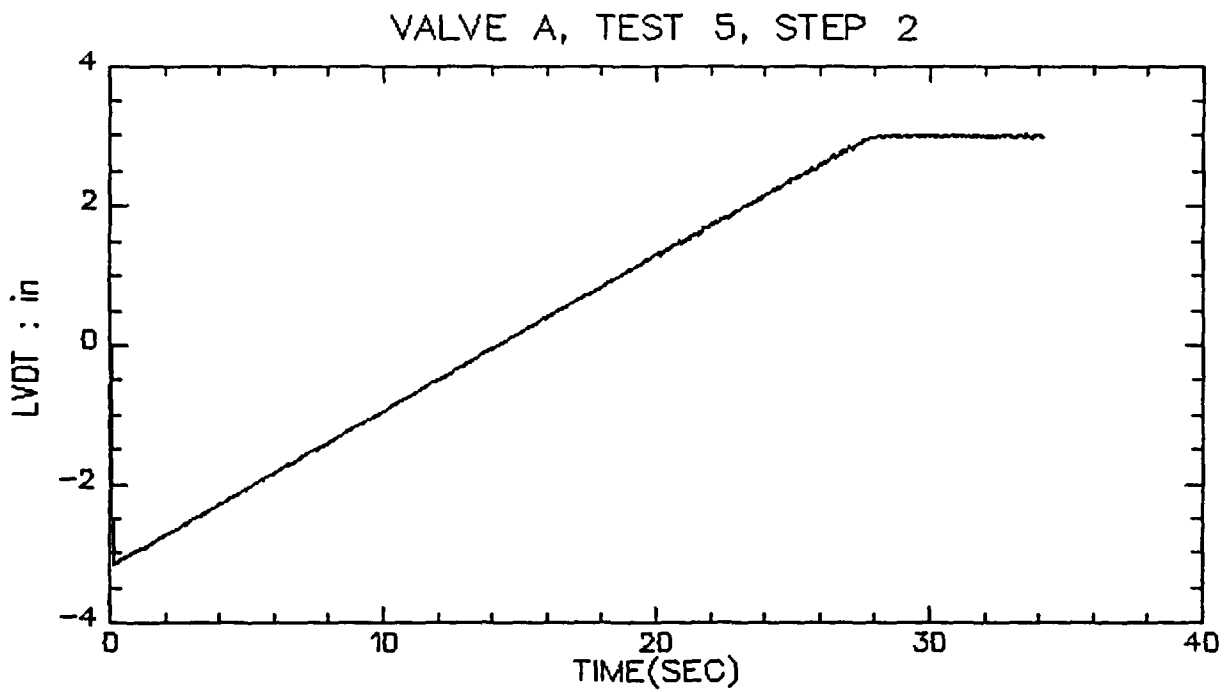
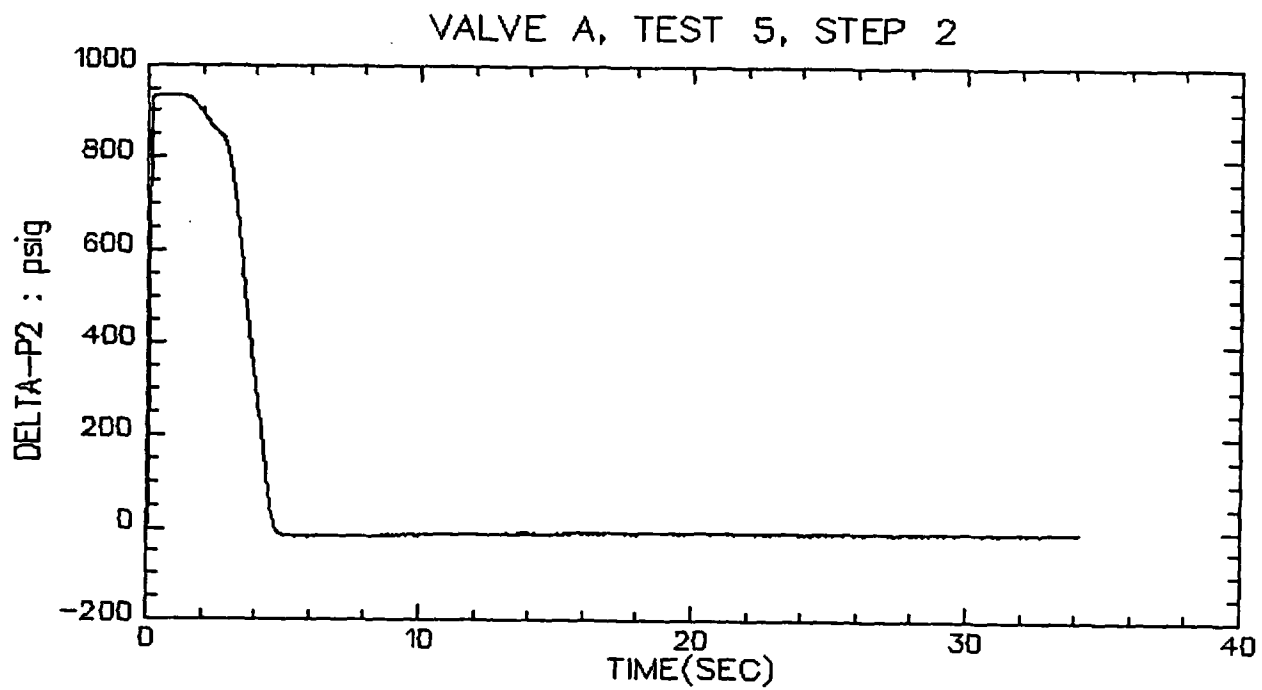

VALVE A, TEST 5, STEP 2

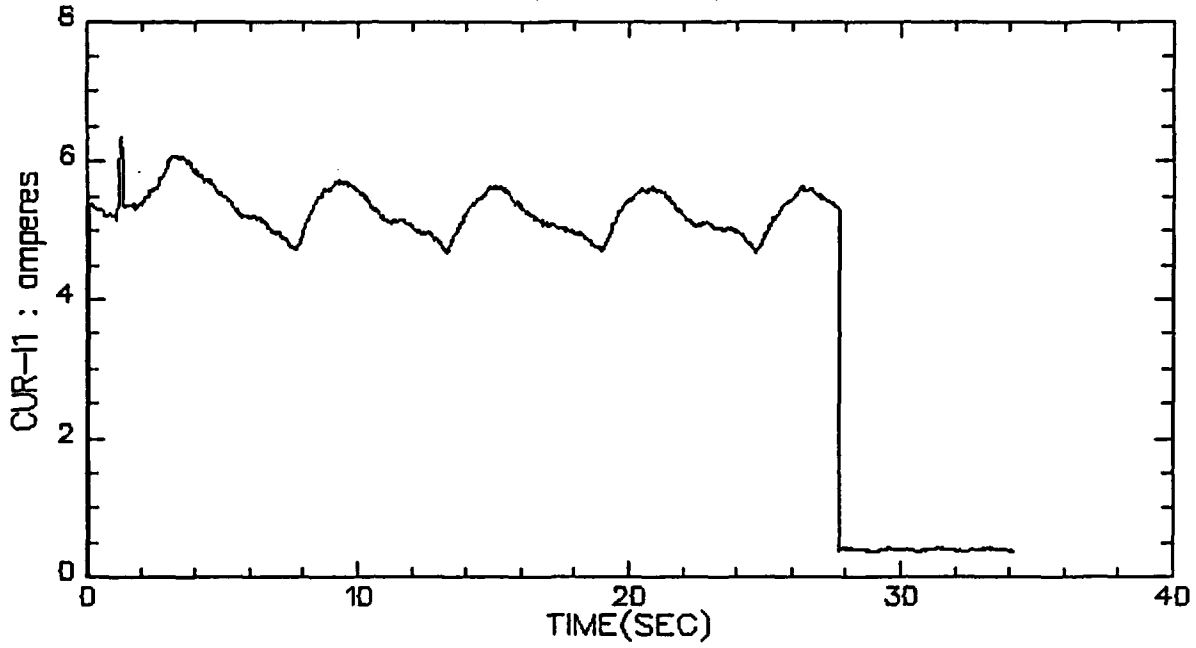

VALVE A, TEST 5, STEP 2

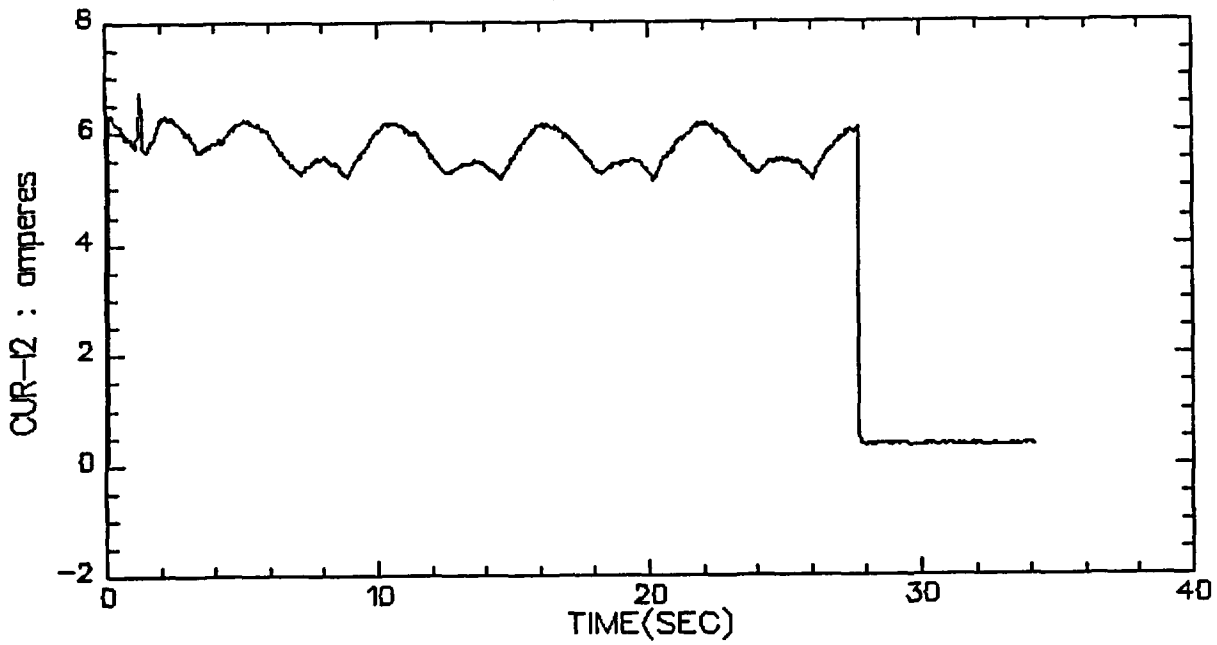

VALVE A, TEST 5, STEP 2

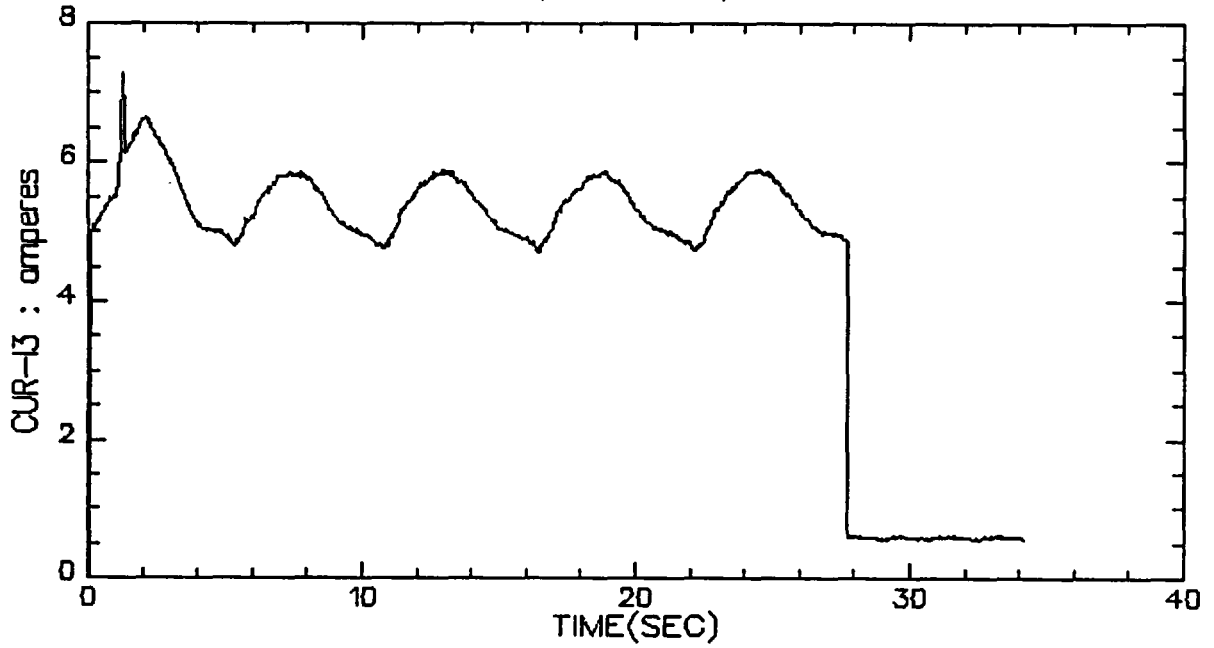

VALVE A, TEST 5, STEP 2

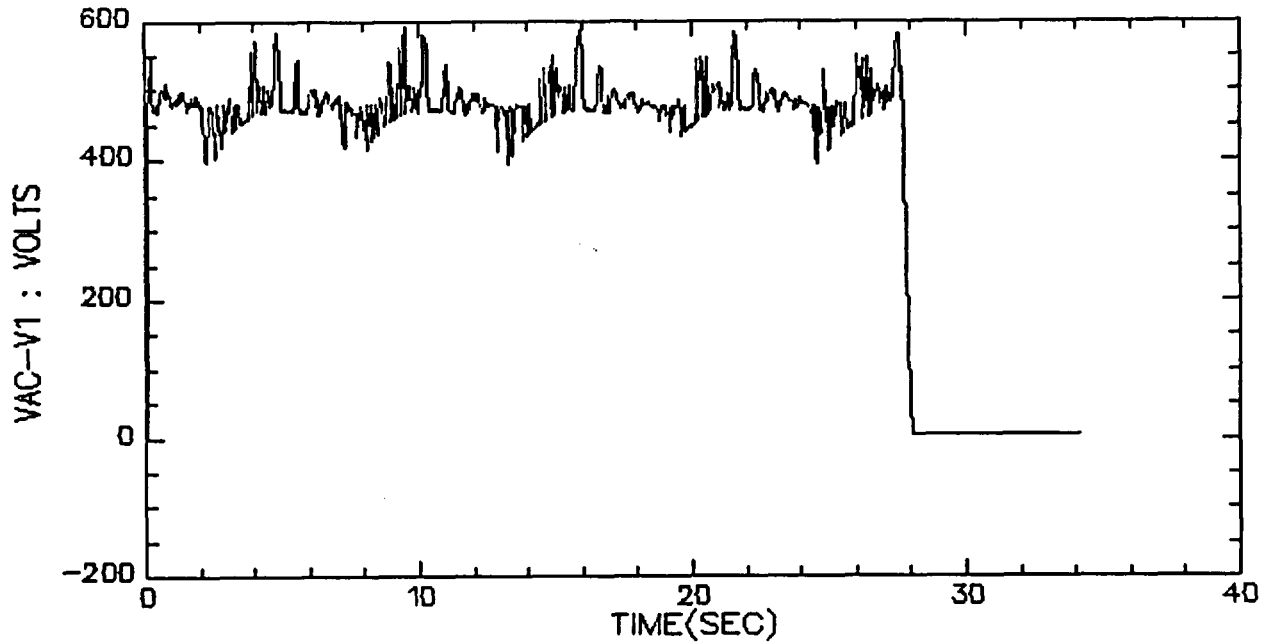

VALVE A, TEST 5, STEP 2

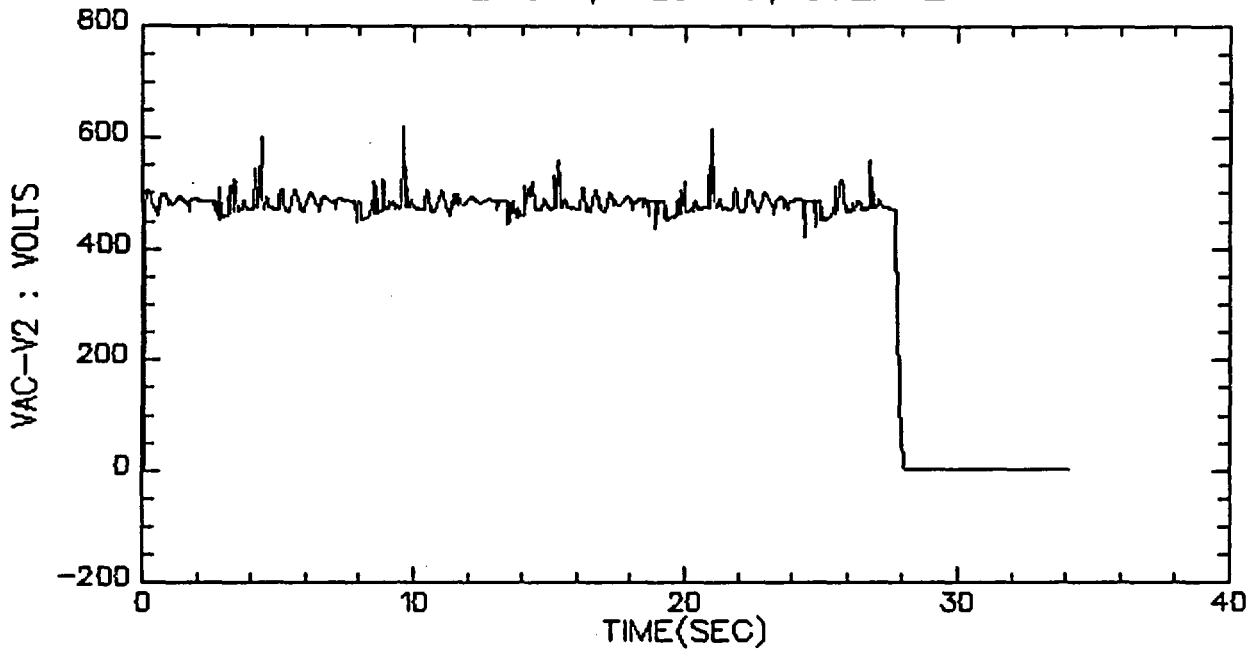

VALVE A, TEST 5, STEP 2

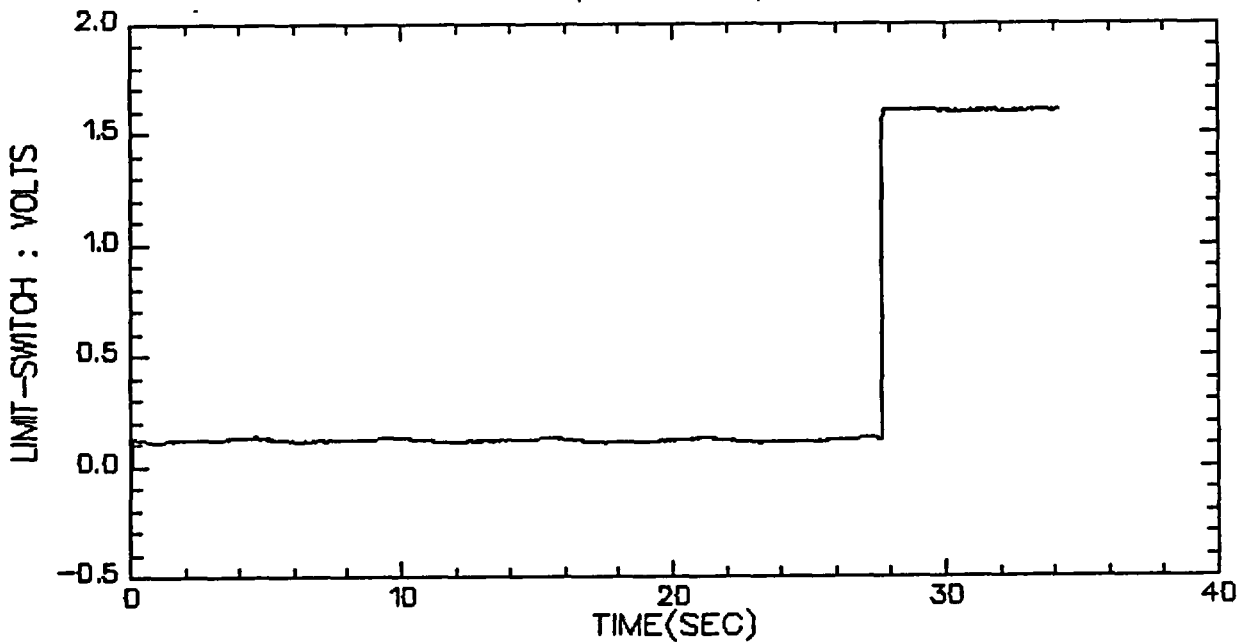

VALVE A, TEST 5, STEP 2

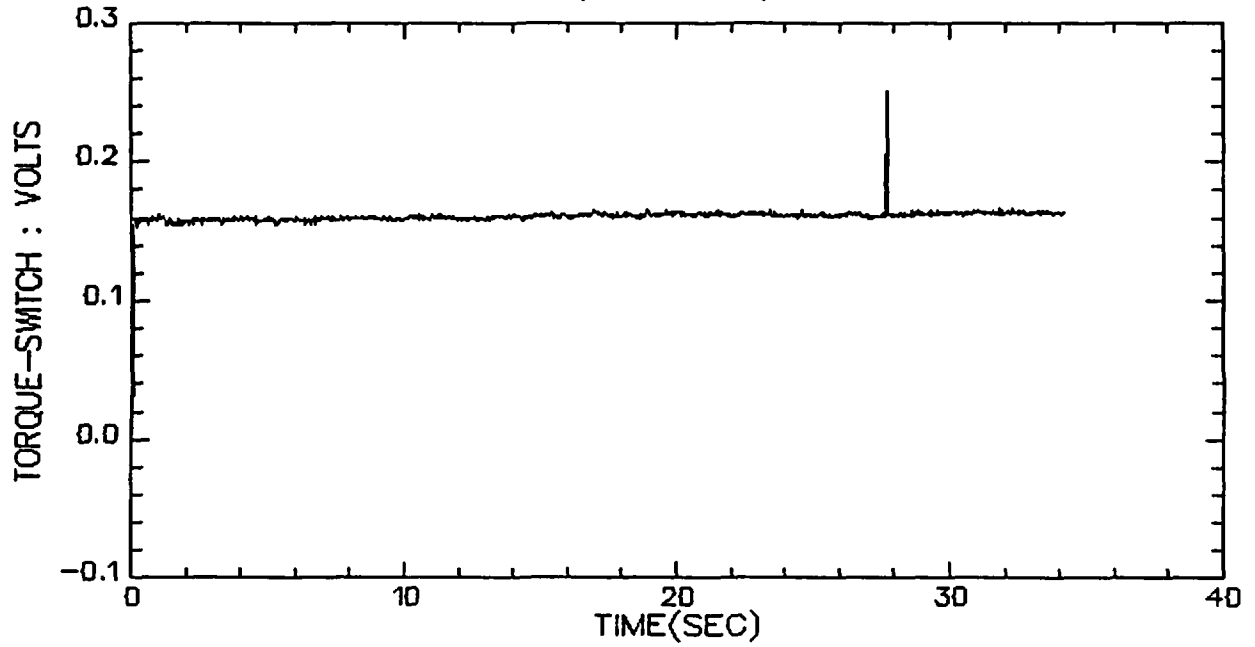

VALVE A, TEST 5, STEP 2

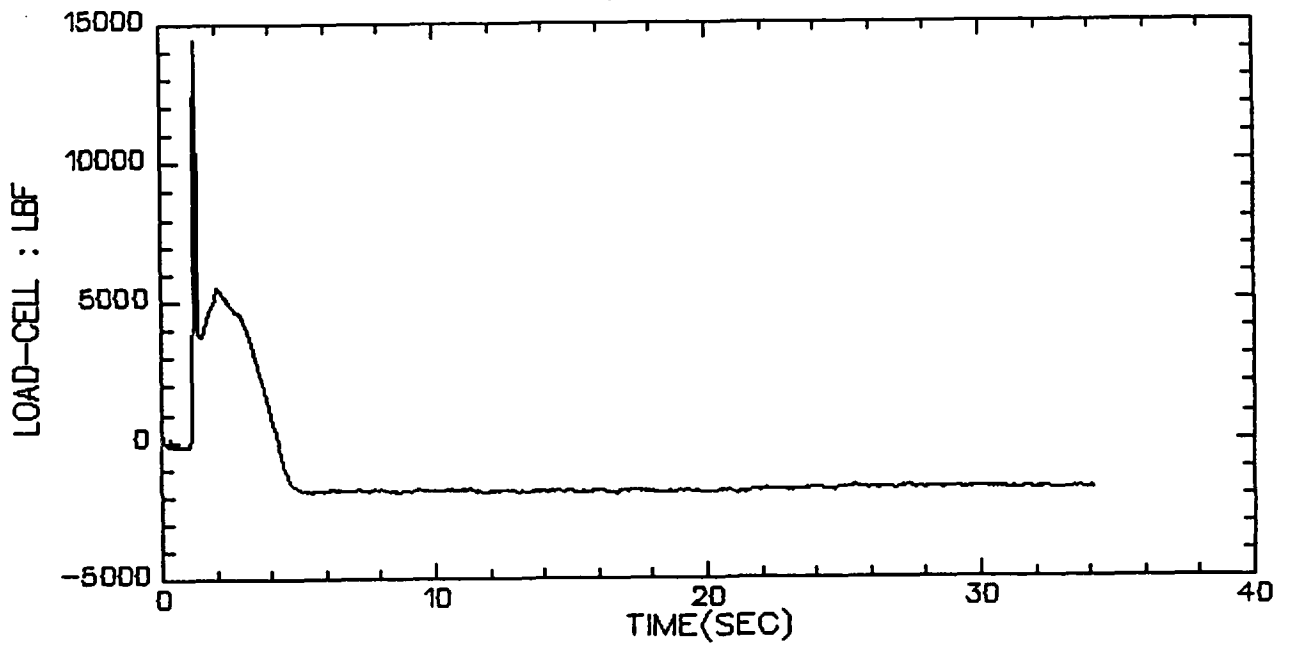

VALVE A, TEST 5, STEP 3&4

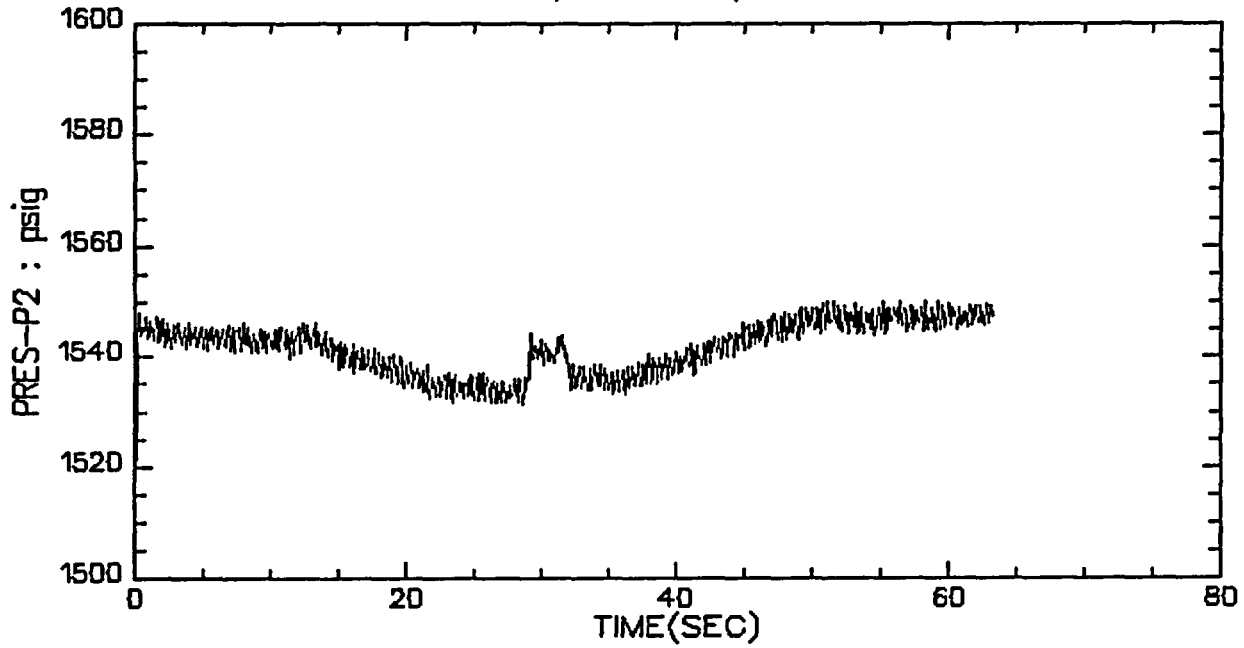

VALVE A, TEST 5, STEP 3&4

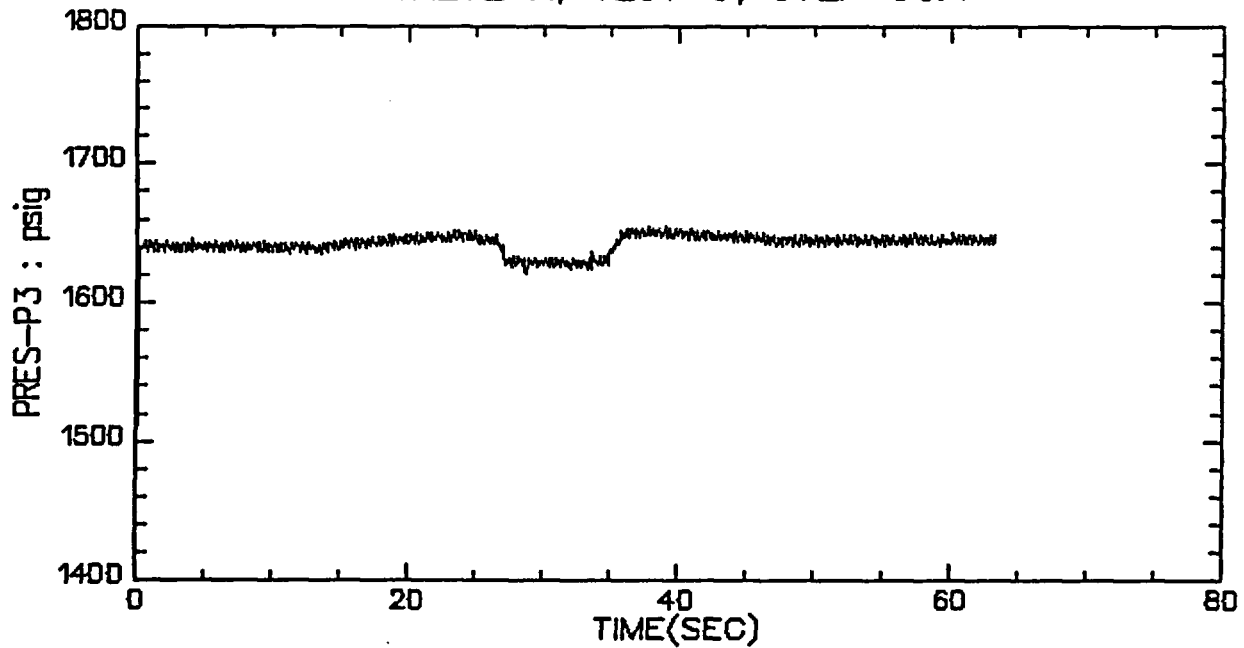

VALVE A, TEST 5, STEP 3&4

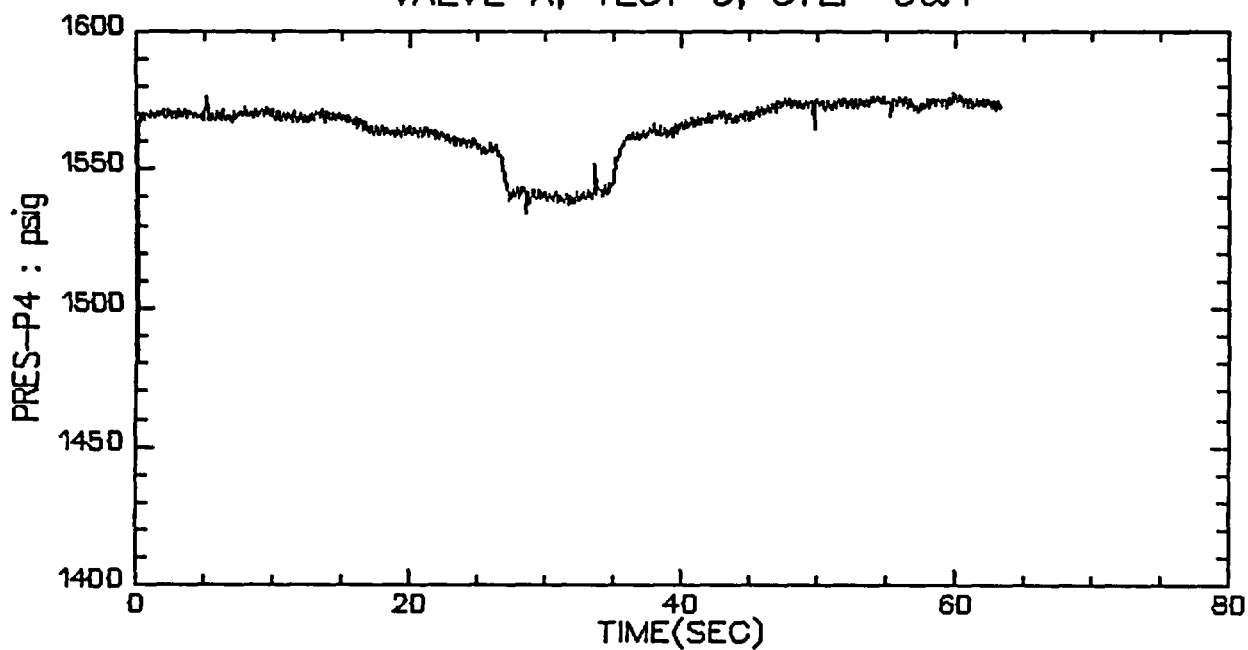

VALVE A, TEST 5, STEP 3&4

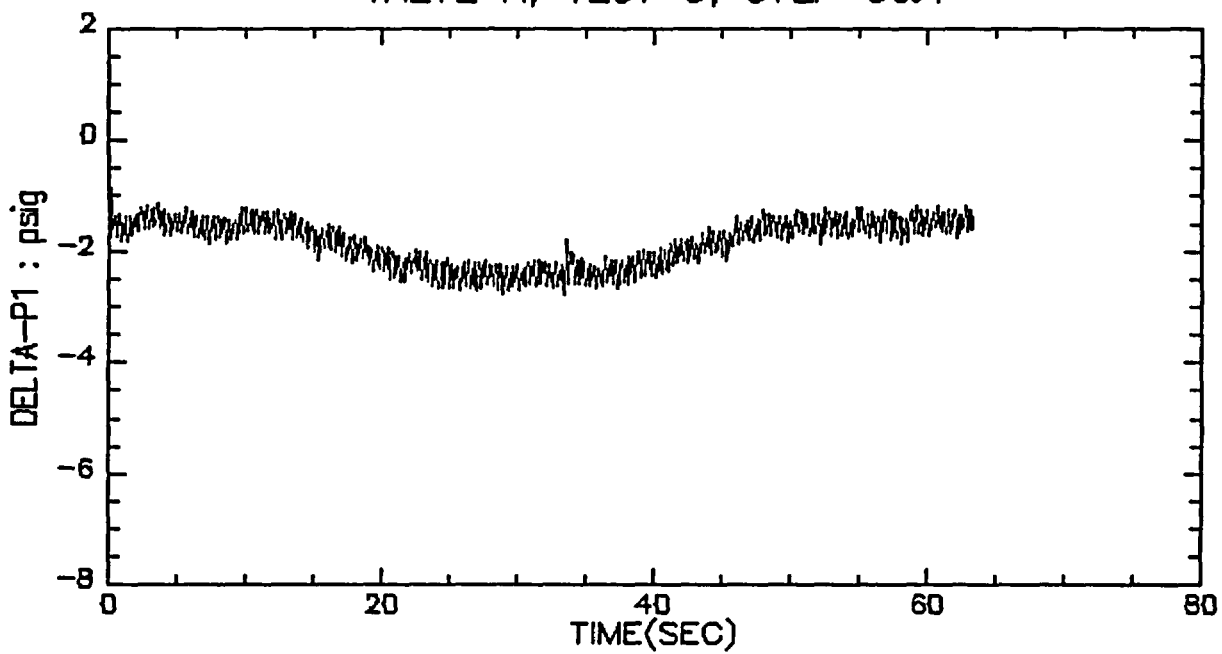

VALVE A, TEST 5, STEP 3&4

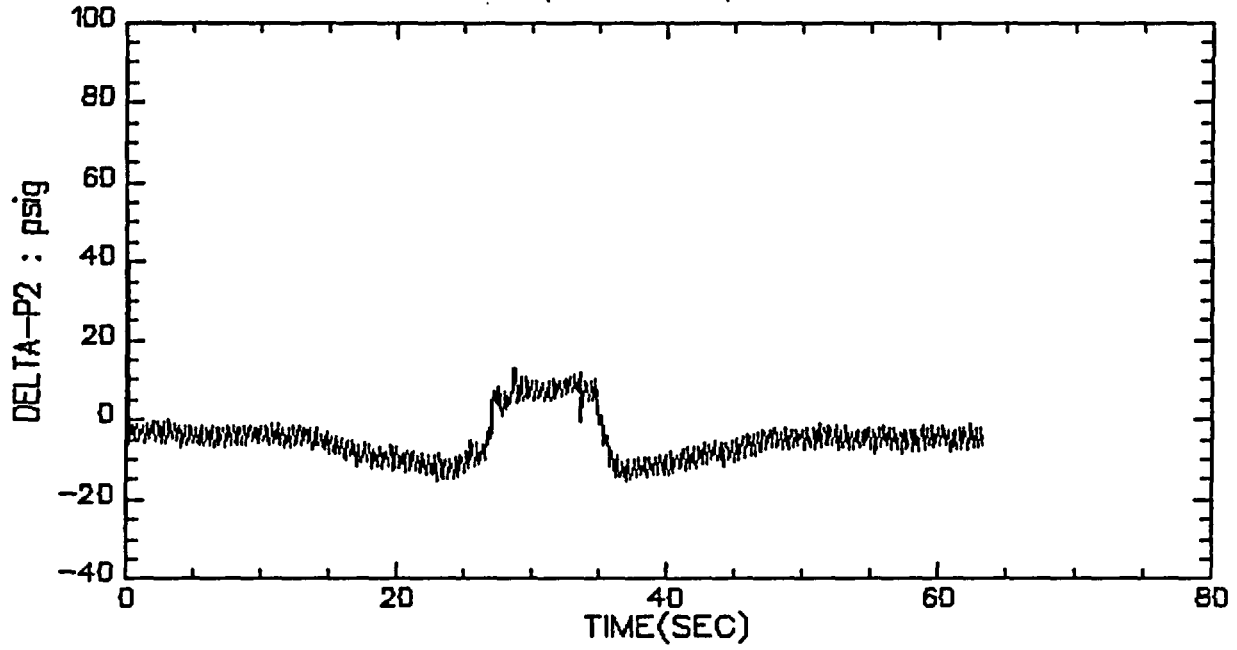

VALVE A, TEST 5, STEP 3&4

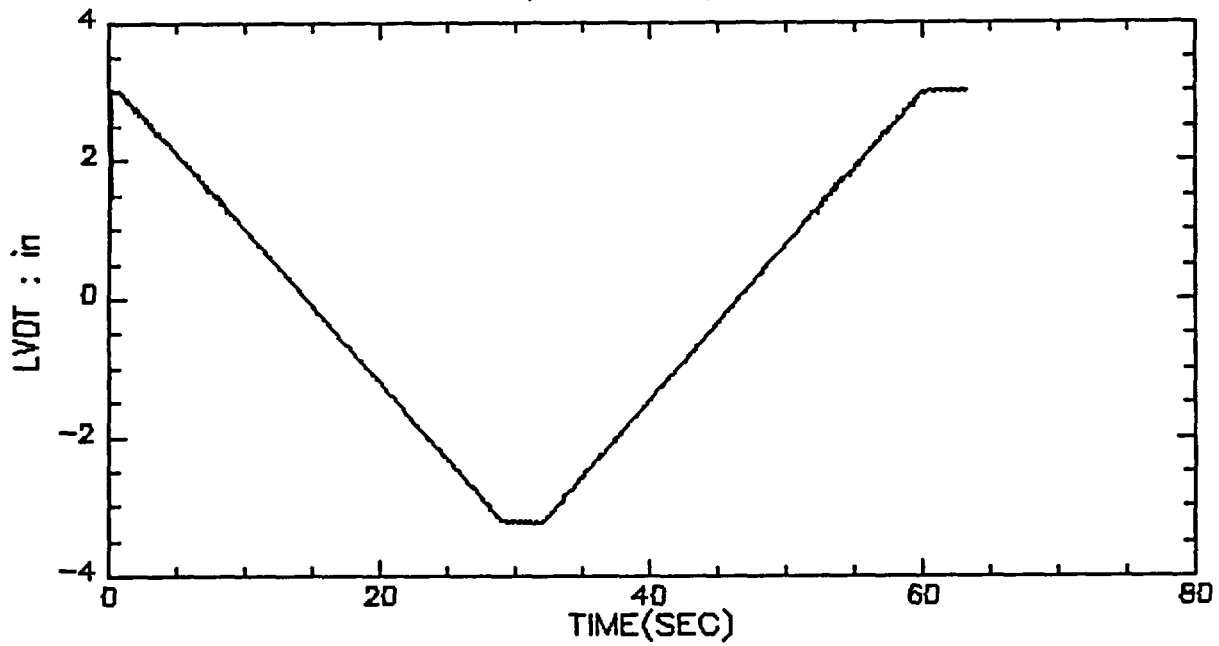

VALVE A, TEST 5, STEP 3&4

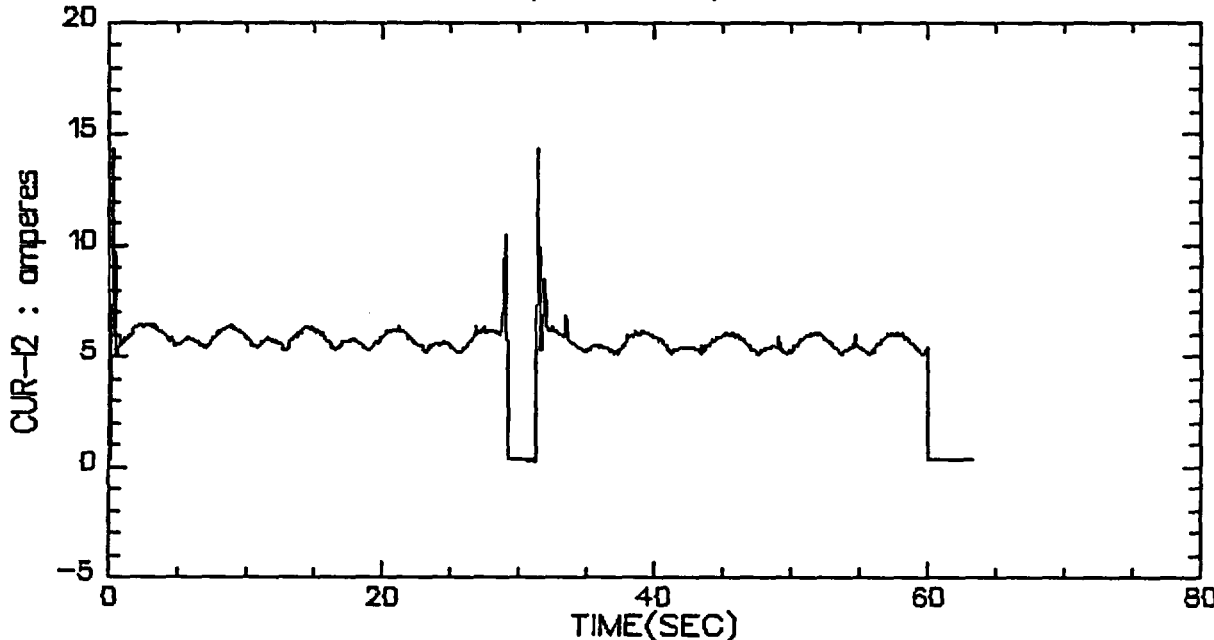

VALVE A, TEST 5, STEP 3&4

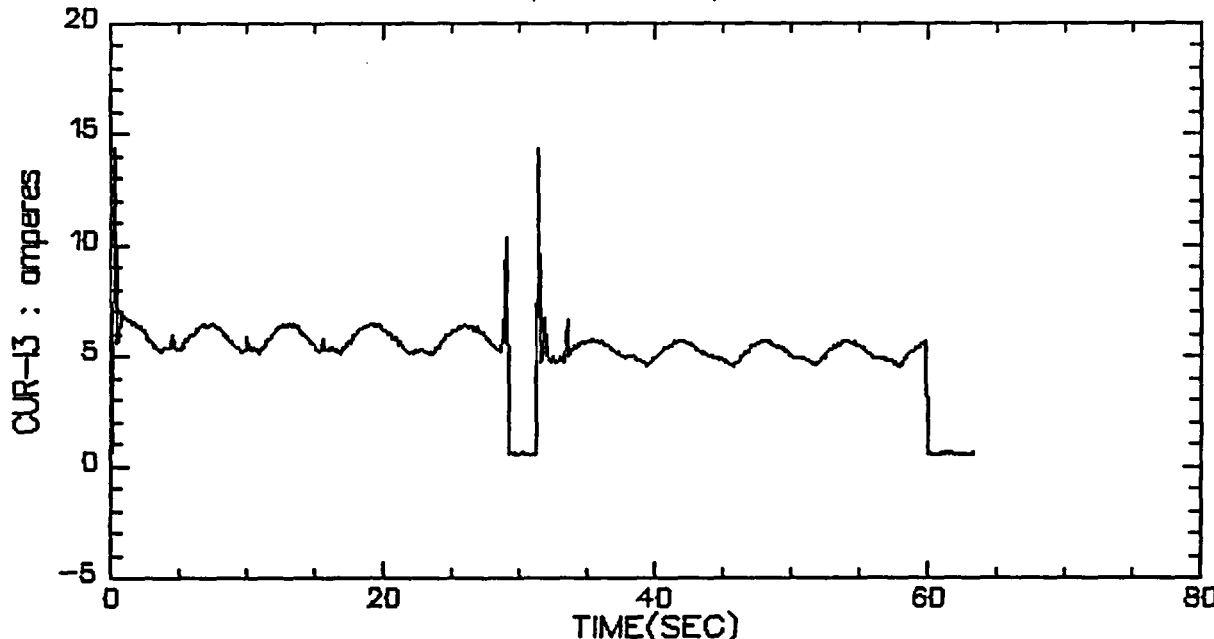

VALVE A, TEST 5, STEP 3&4

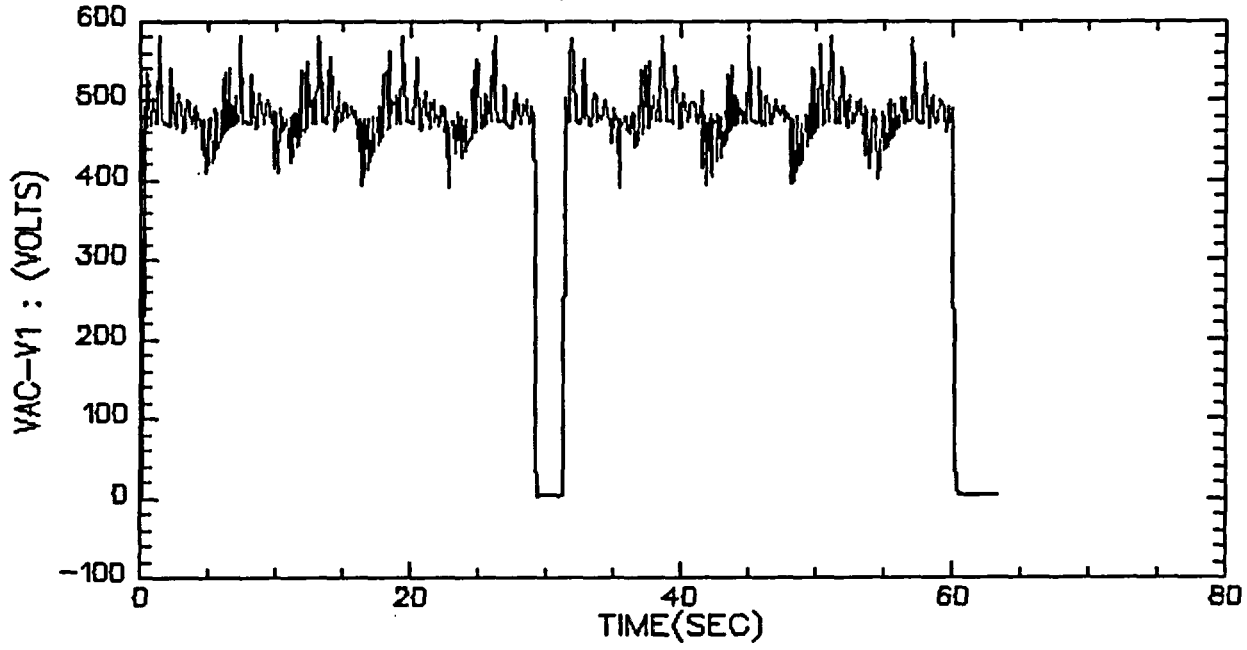

VALVE A, TEST 5, STEP 3&4

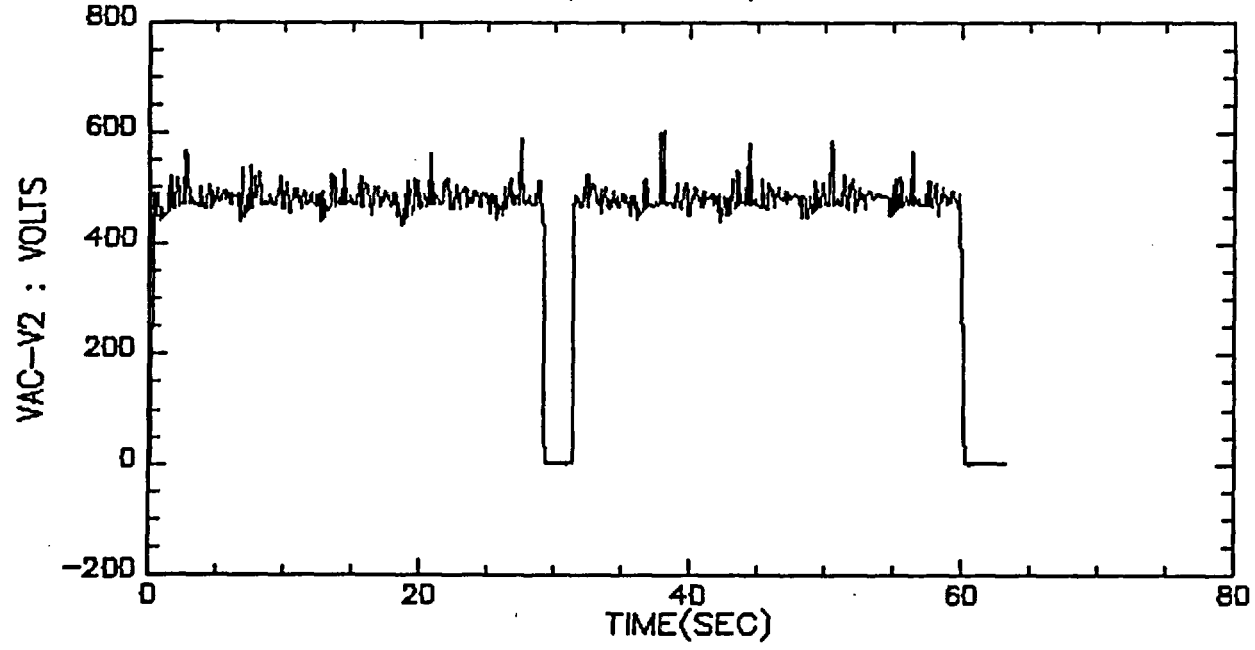

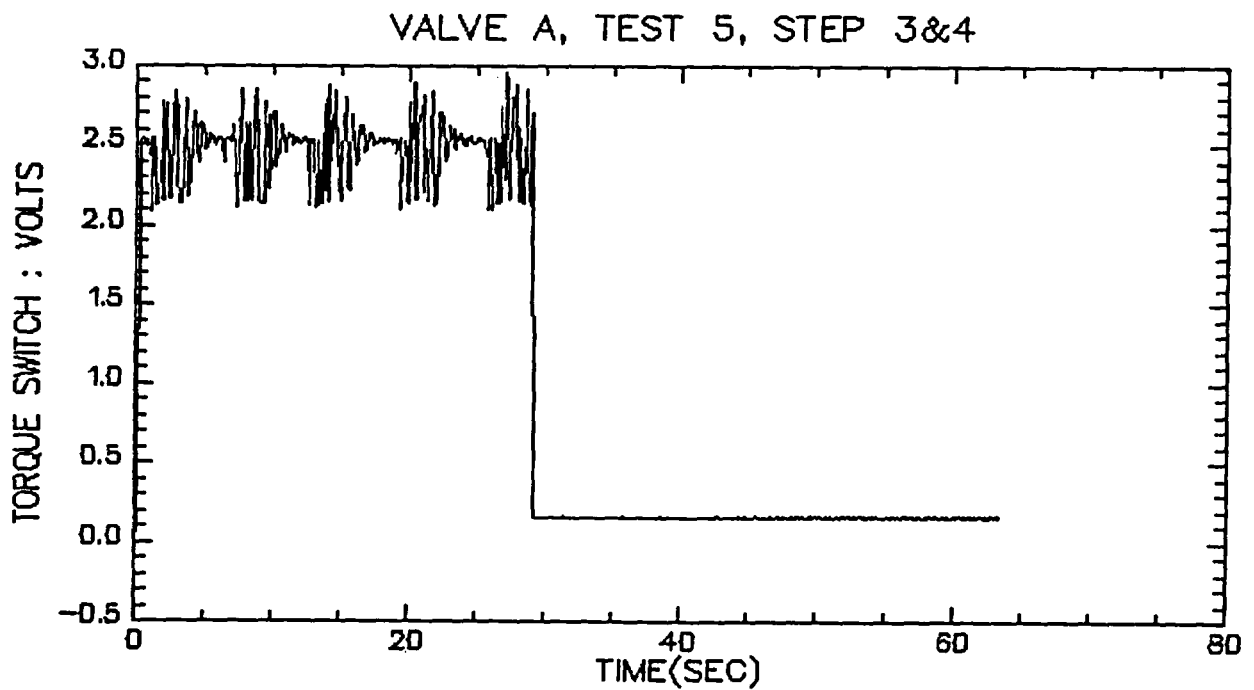
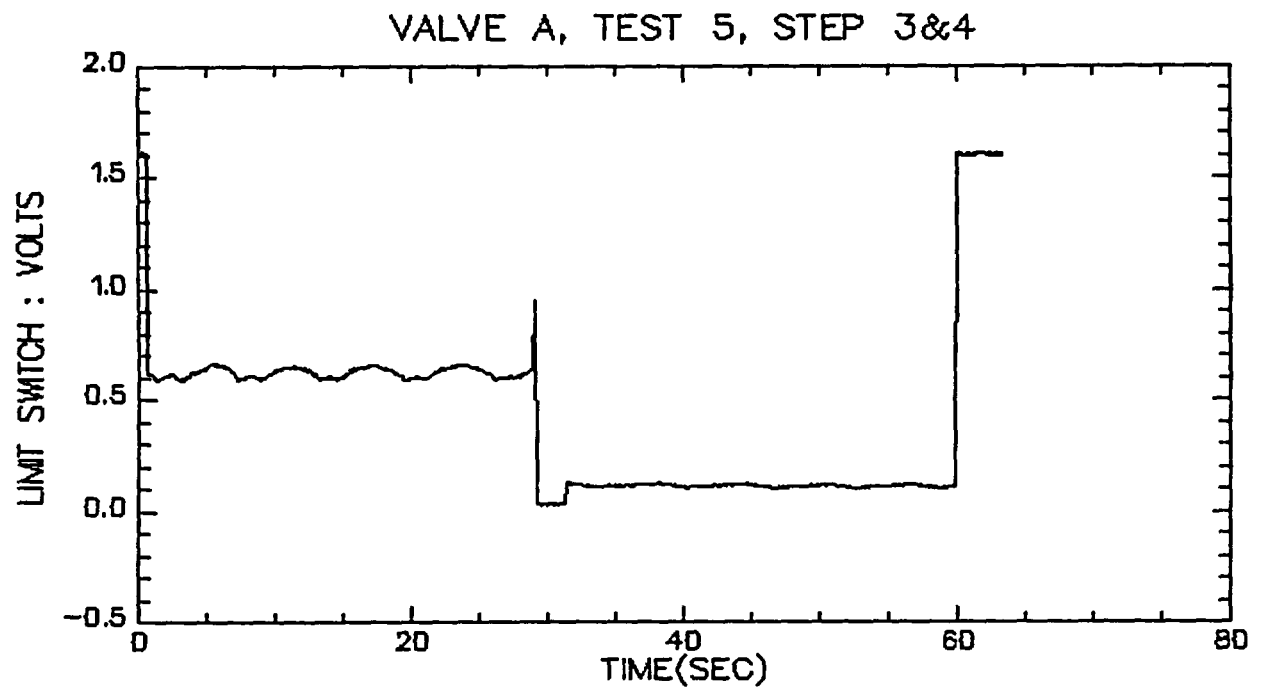

VALVE A, TEST 5, STEP 3&4

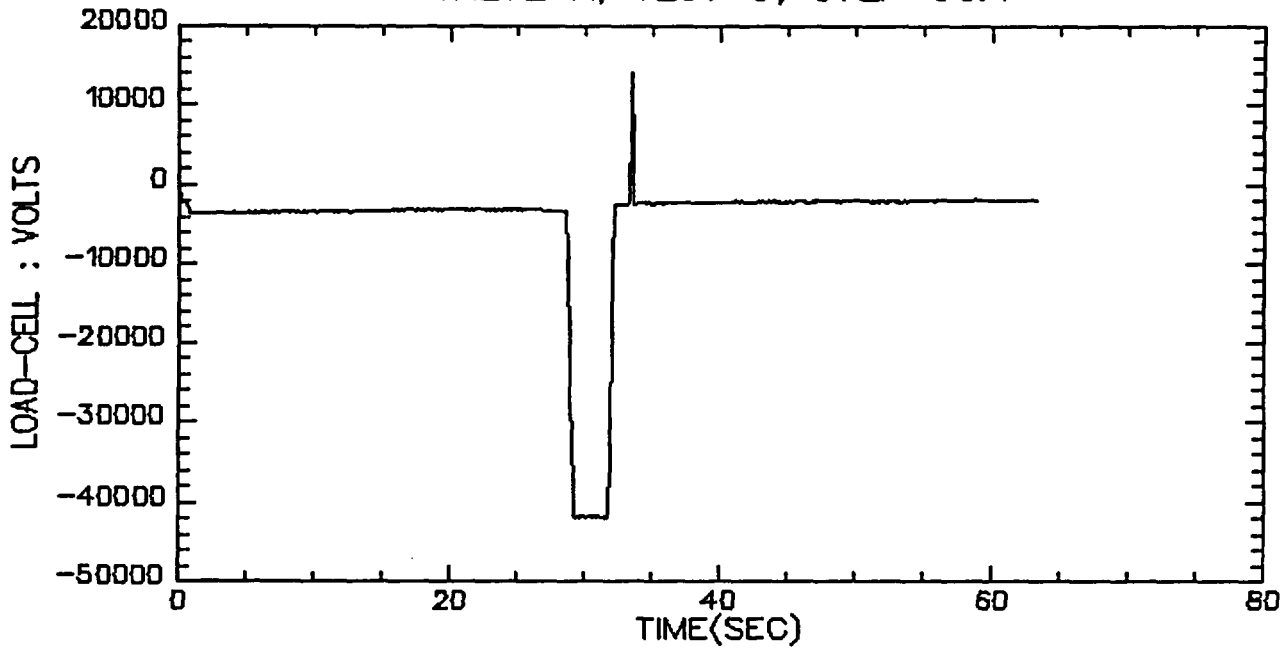

VALVE A, TEST 5, STEP 5

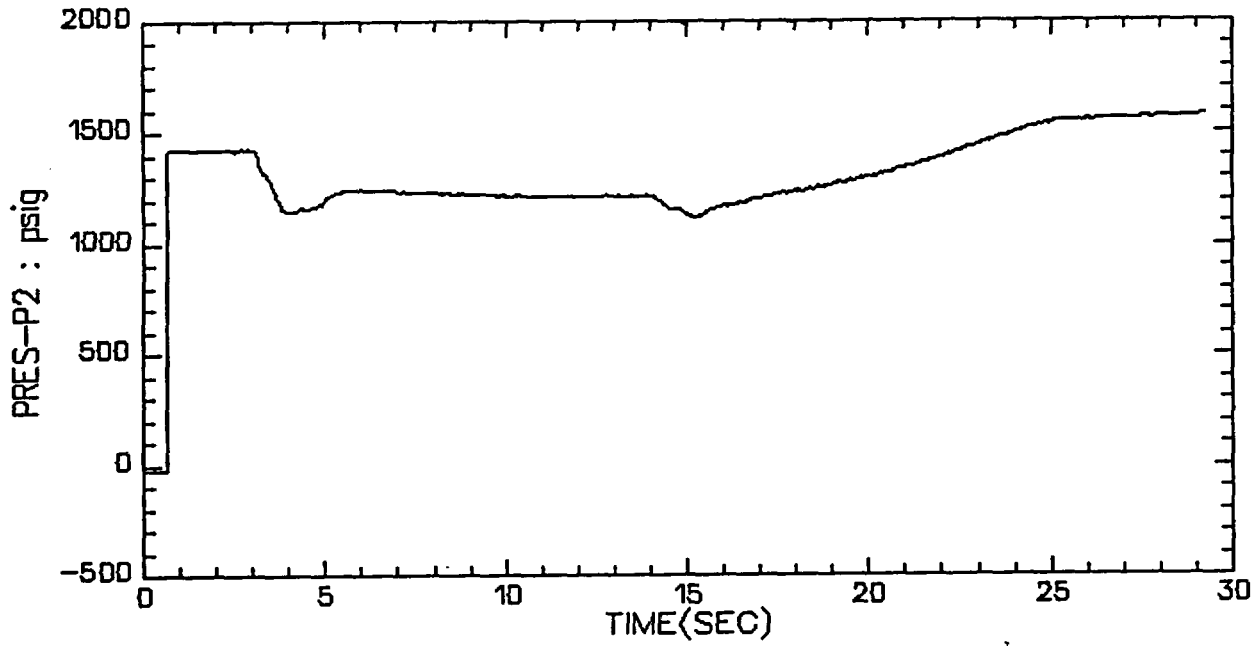

VALVE A, TEST 5, STEP 5

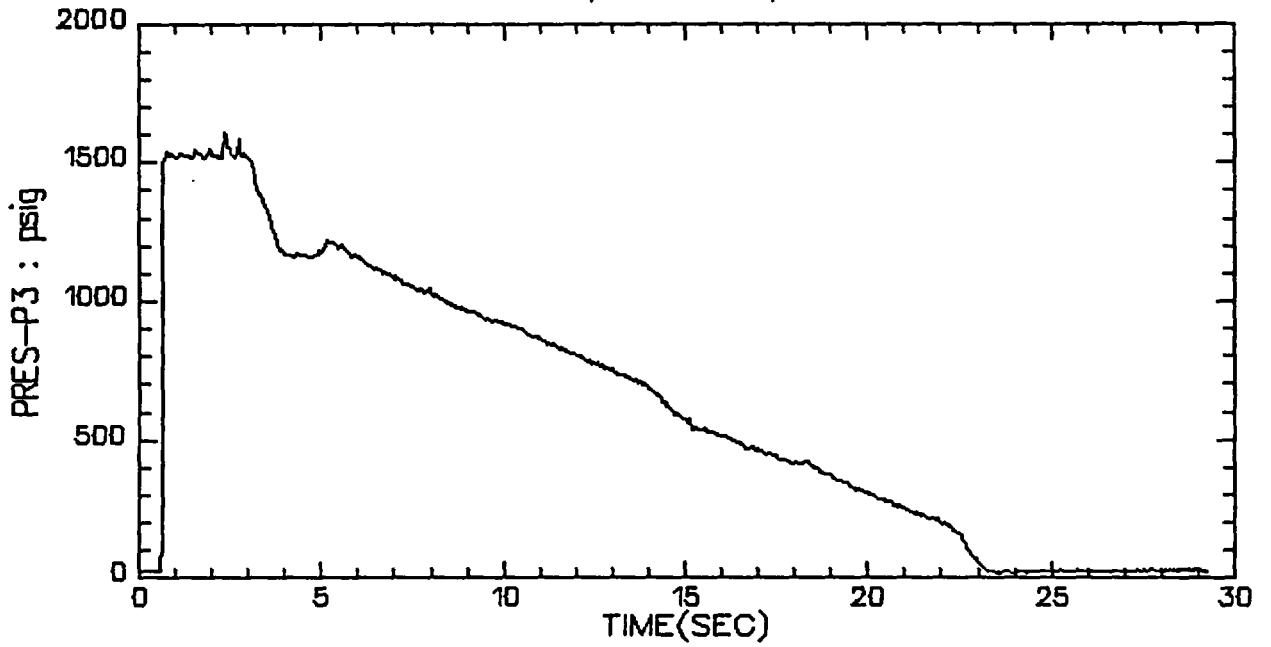

VALVE A, TEST 5, STEP 5

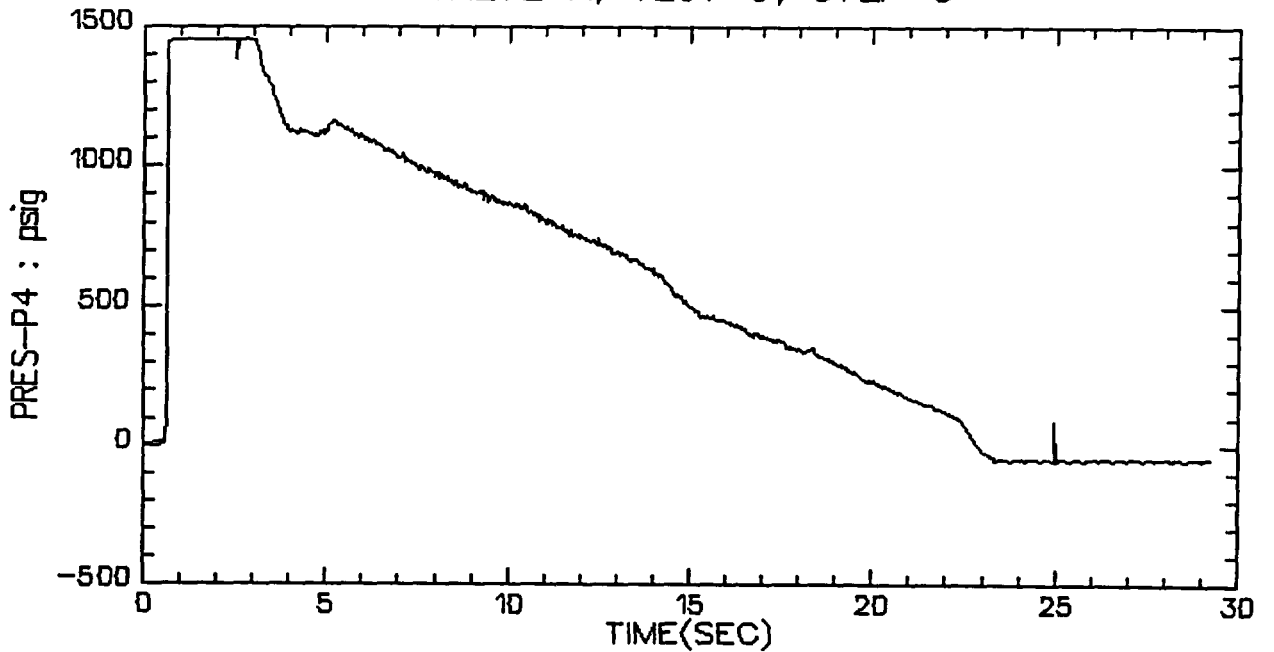

VALVE A, TEST 5, STEP 5

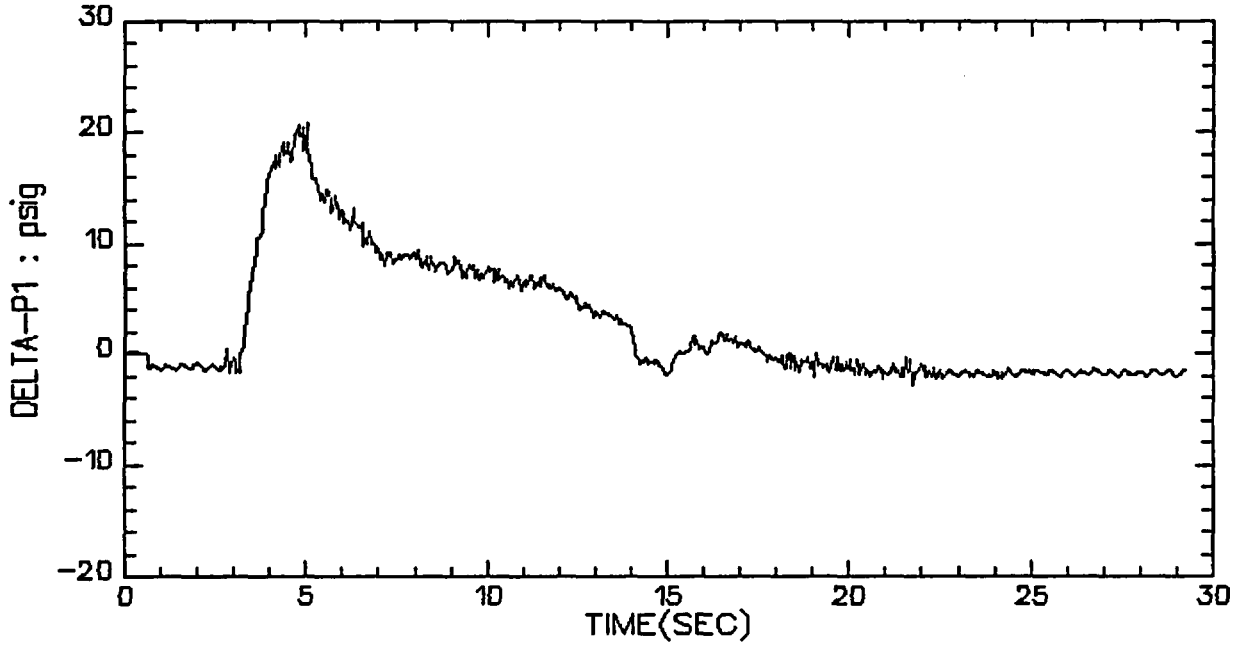

VALVE A, TEST 5, STEP 5

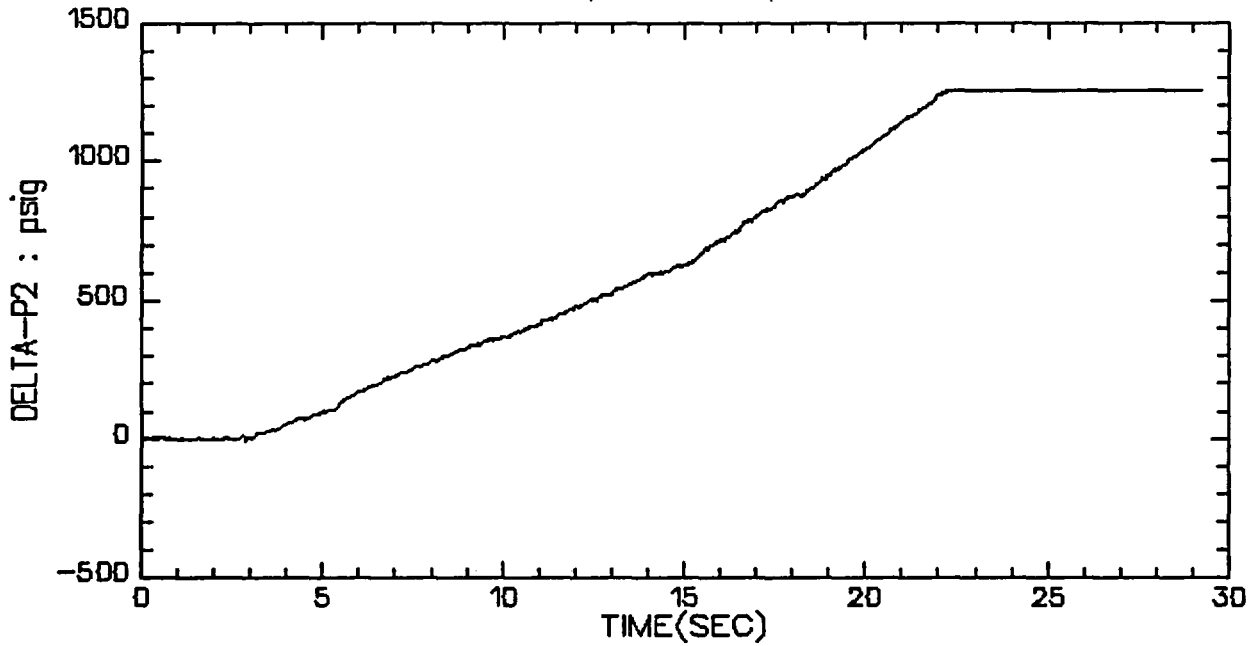

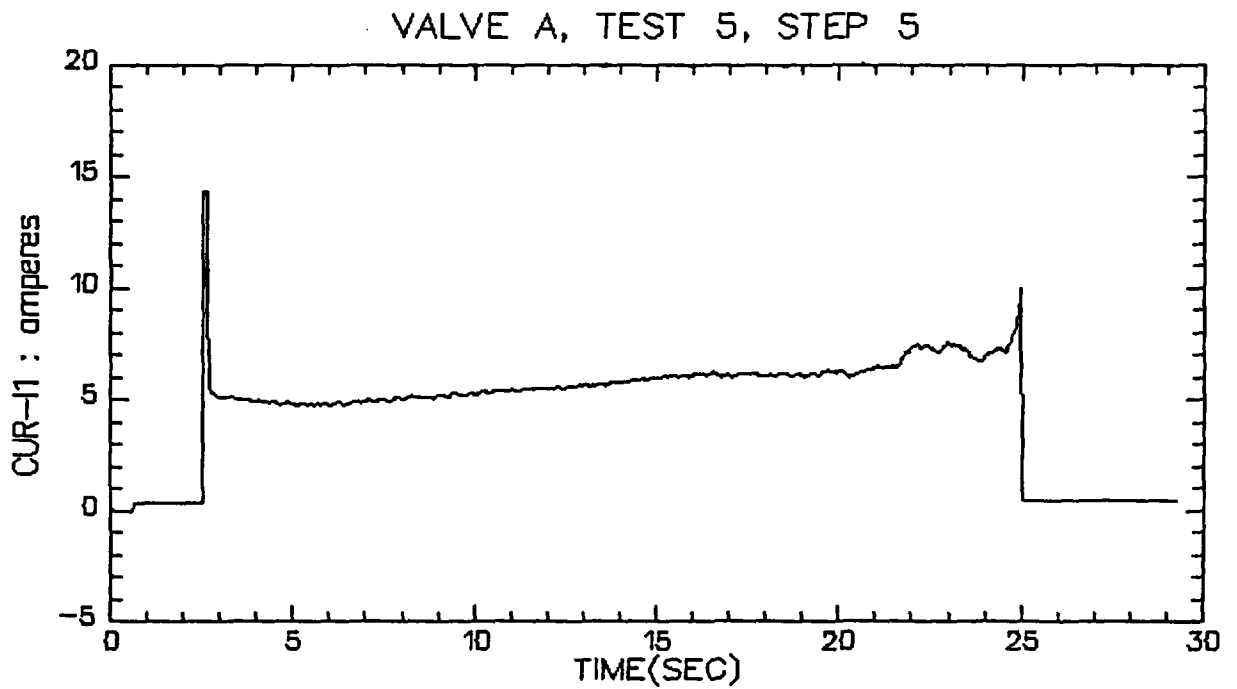
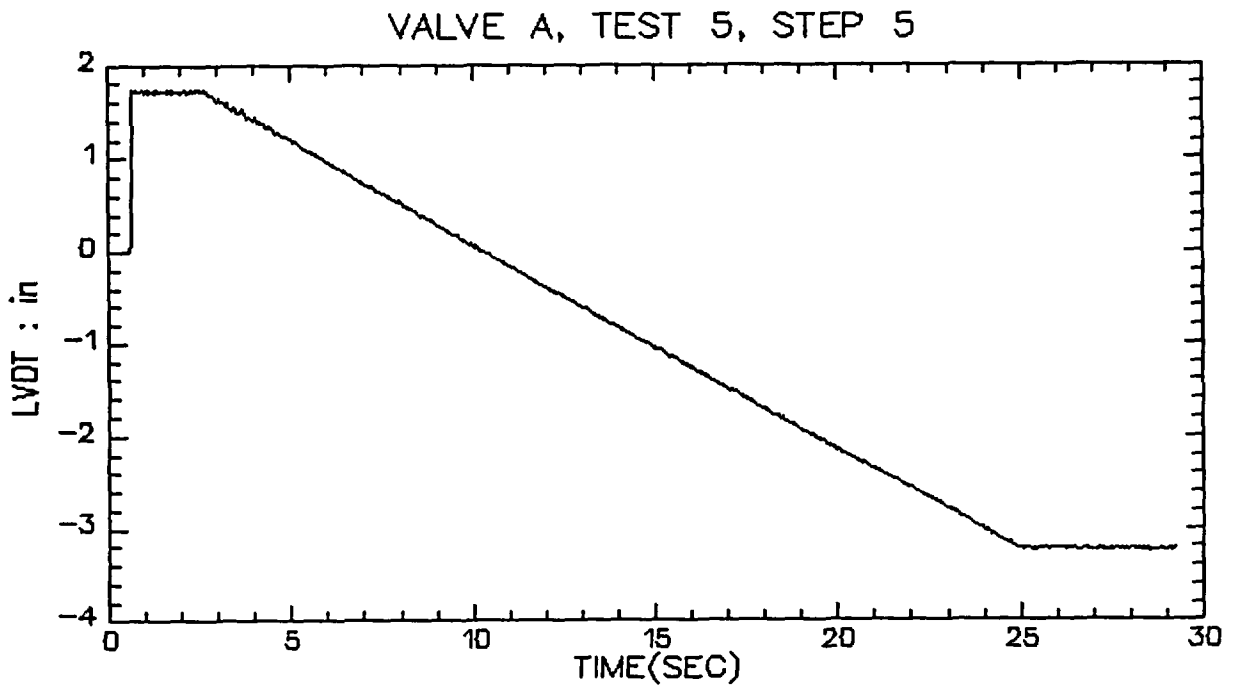

VALVE A, TEST 5, STEP 5

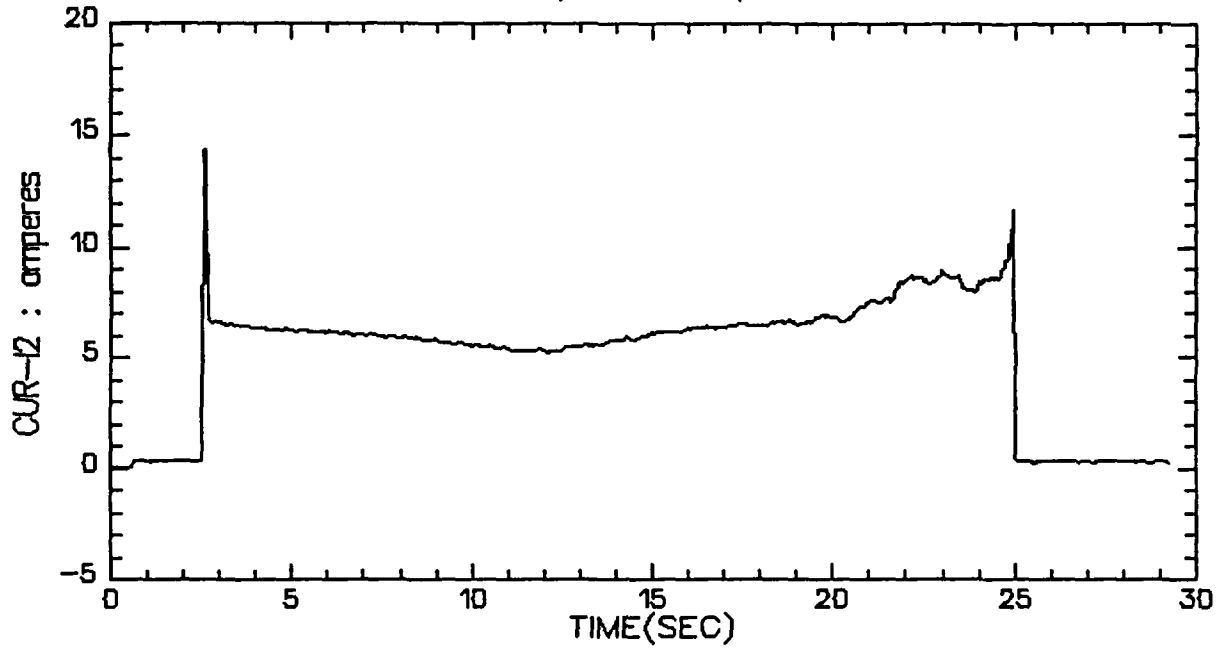

VALVE A, TEST 5, STEP 5

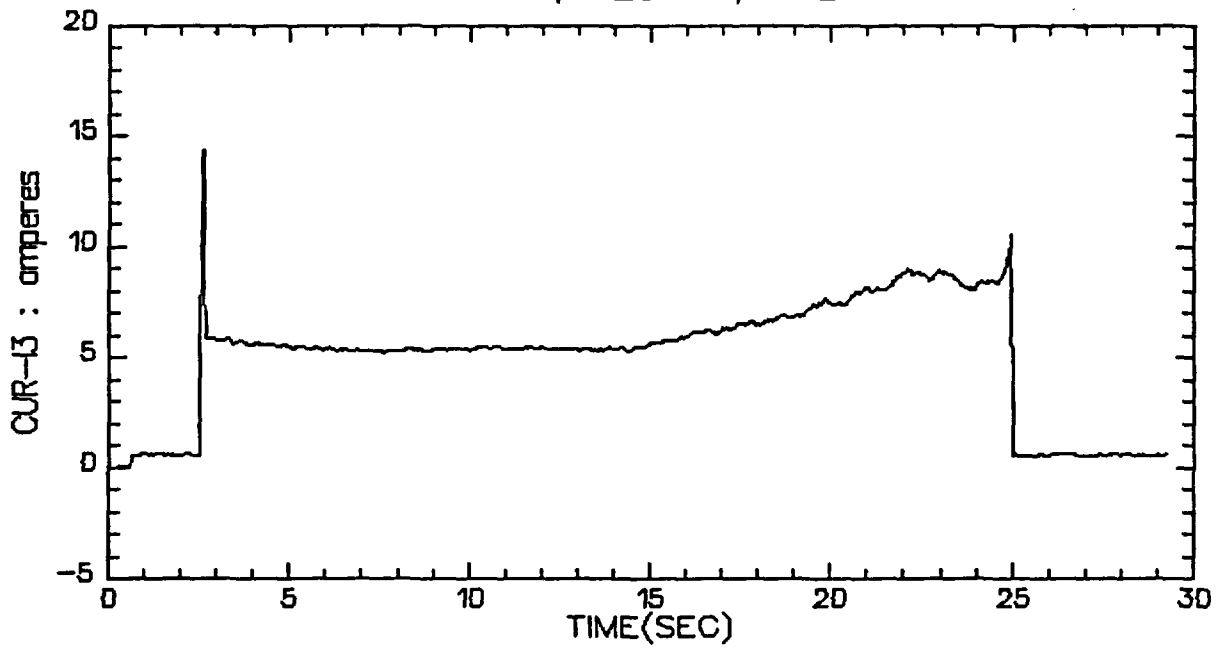

VALVE A, TEST 5, STEP 5

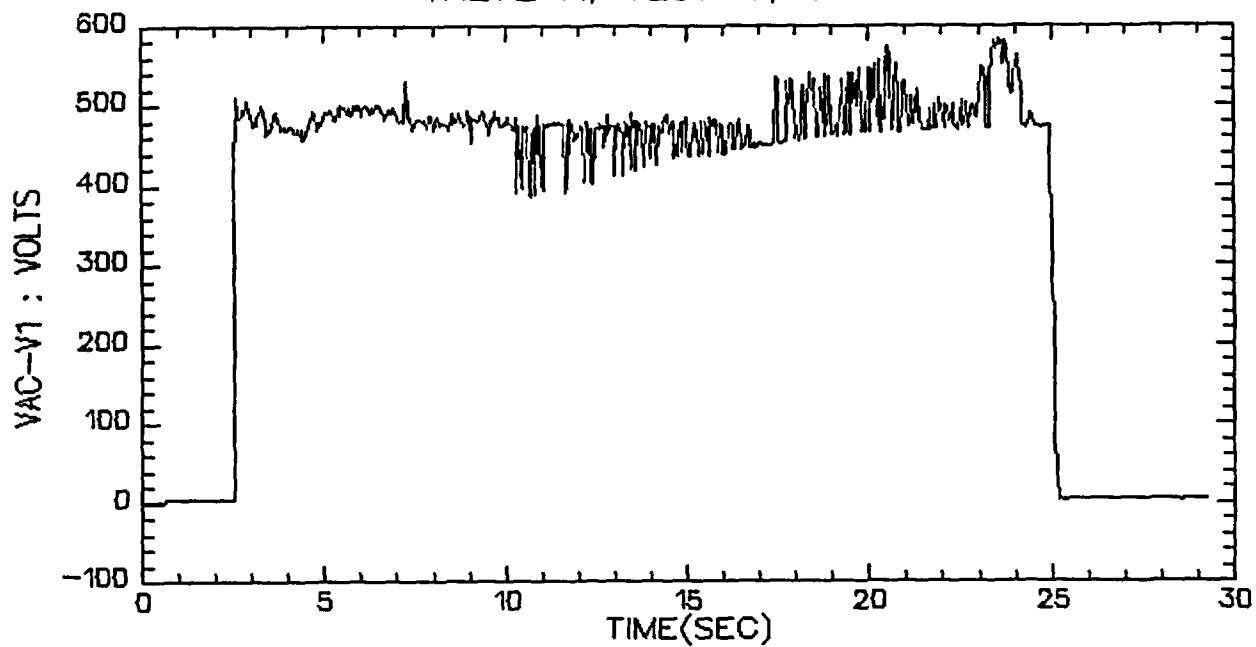

VALVE A, TEST 5, STEP 5

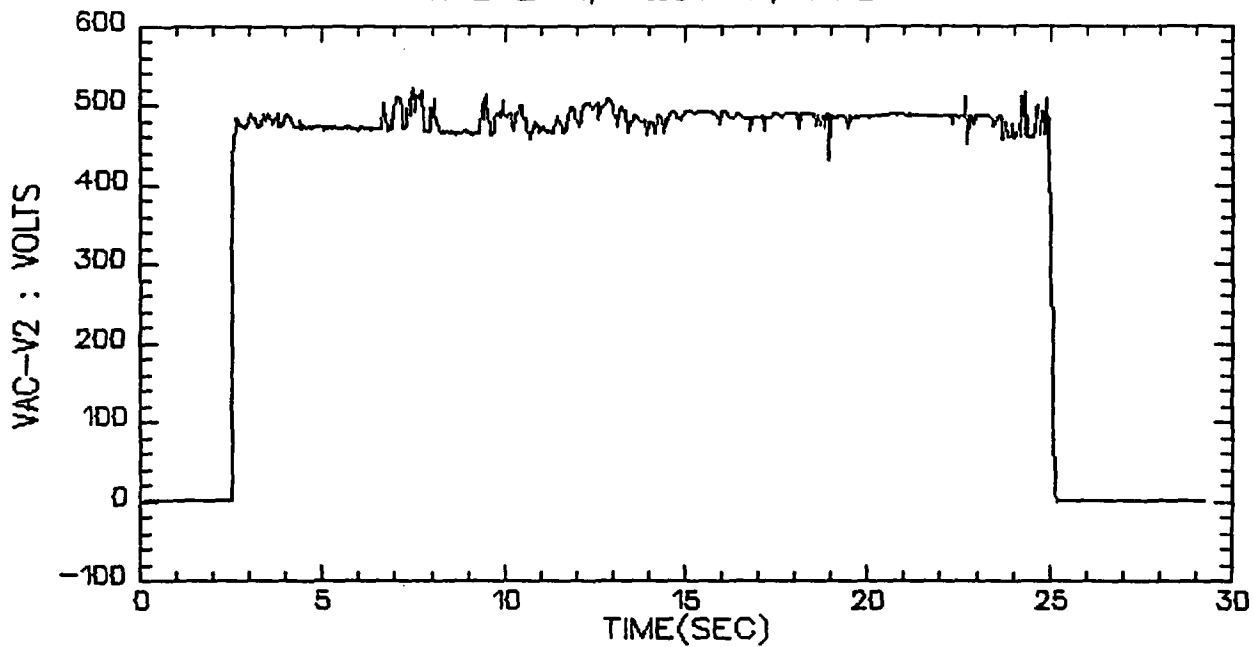

VALVE A, TEST 5, STEP 5

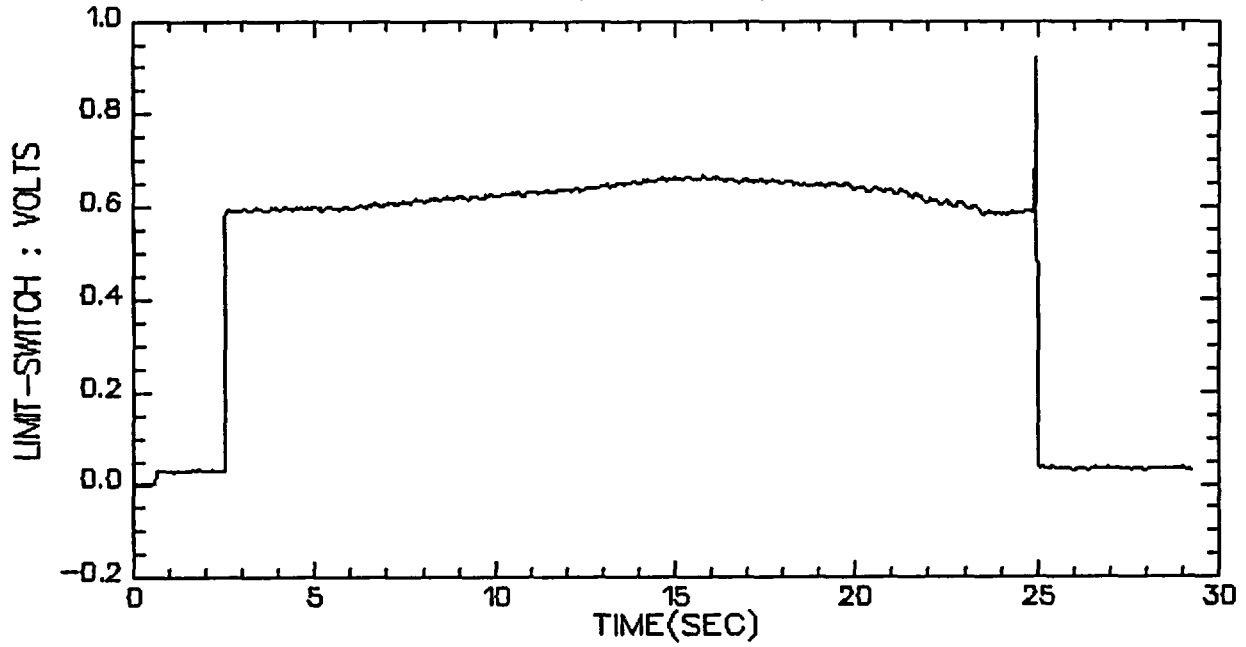

VALVE A, TEST 5, STEP 5

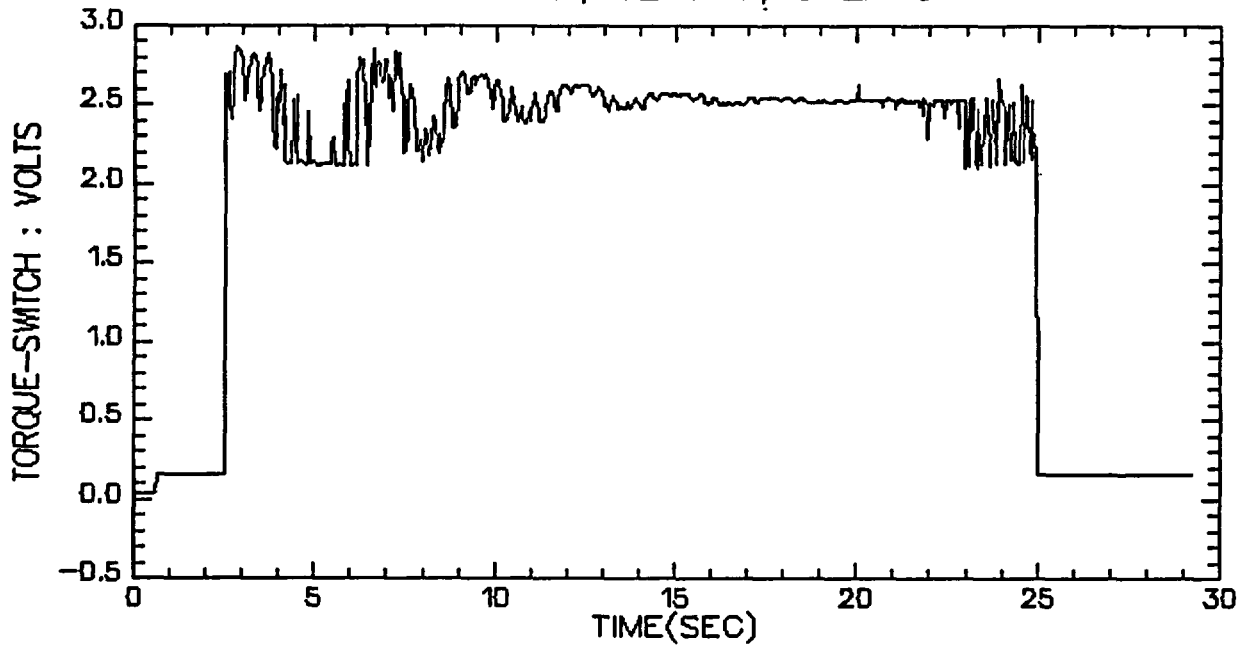

VALVE A, TEST 5, STEP 5

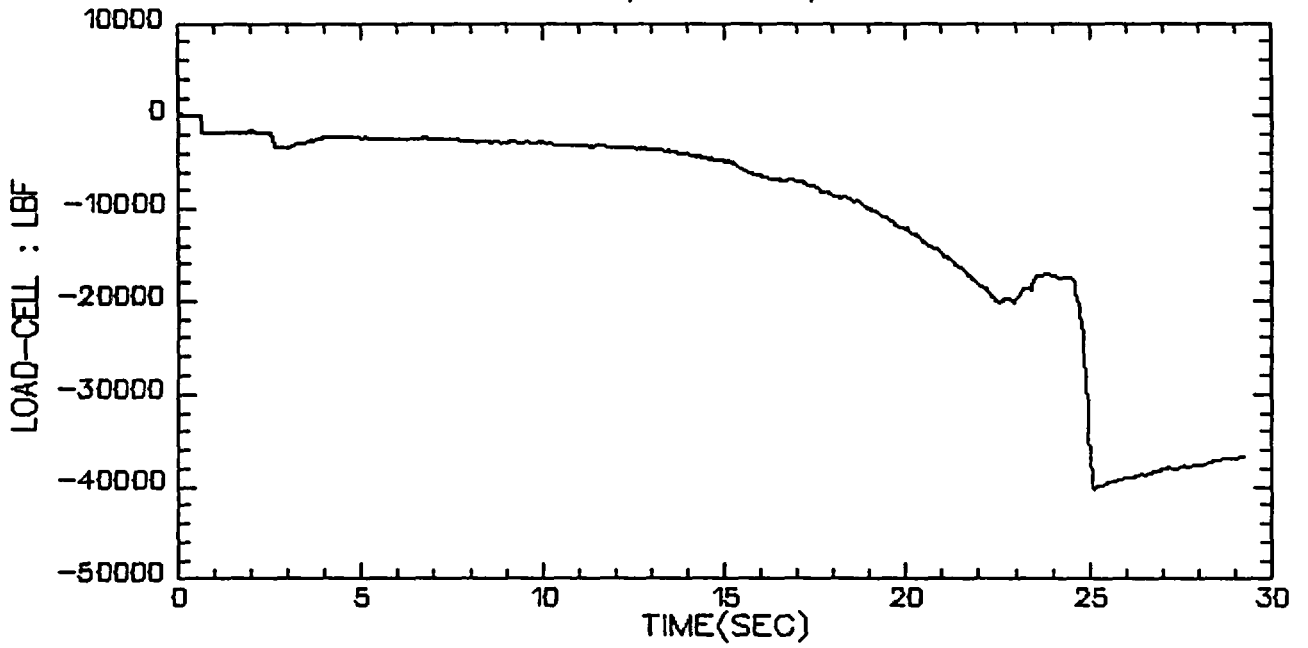

VALVE A, TEST 5, STEP 6&7

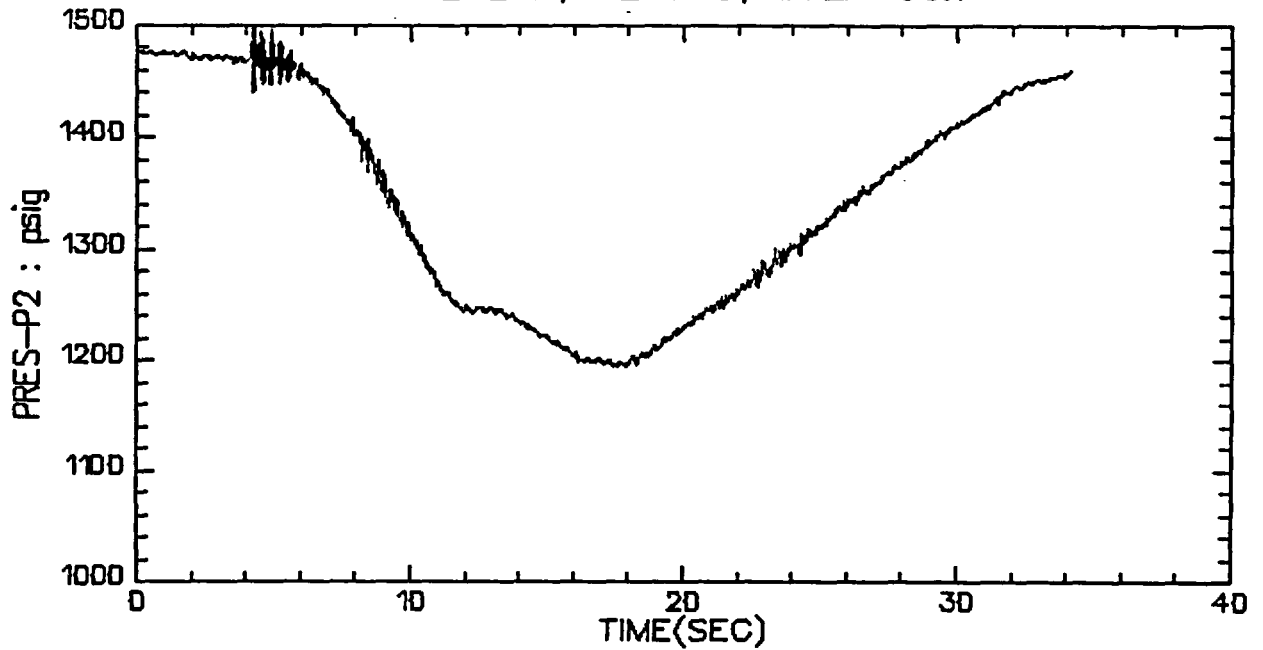

VALVE A, TEST 5, STEP 6&7

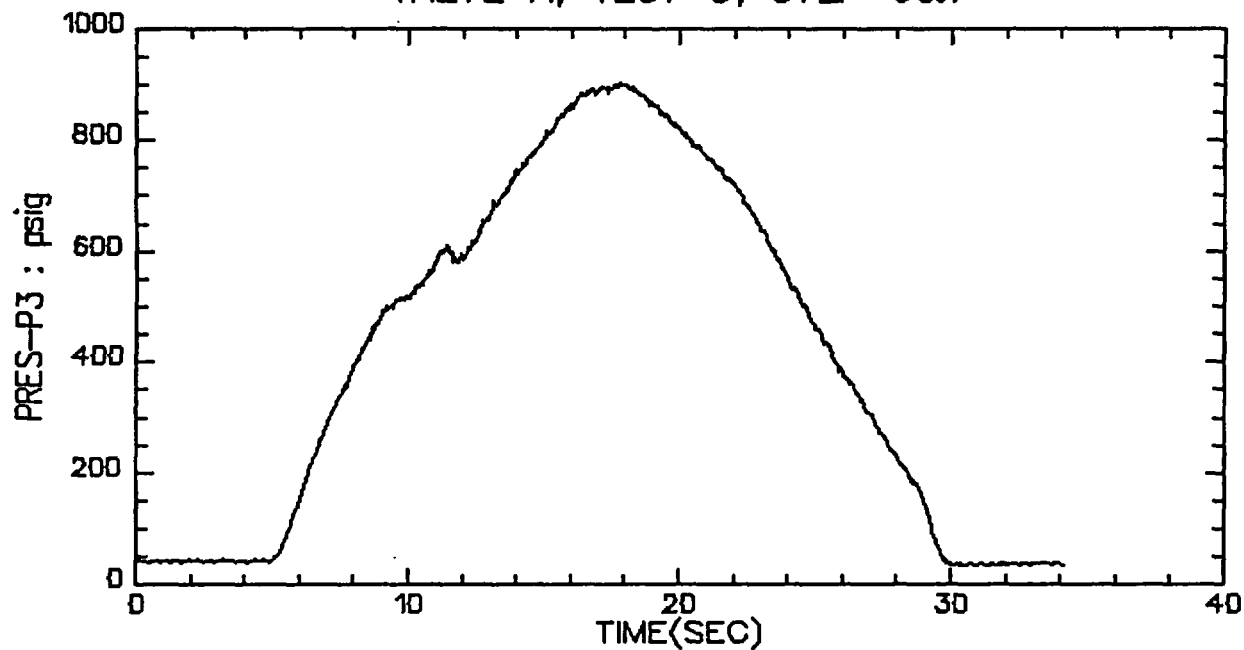

VALVE A, TEST 5, STEP 6&7

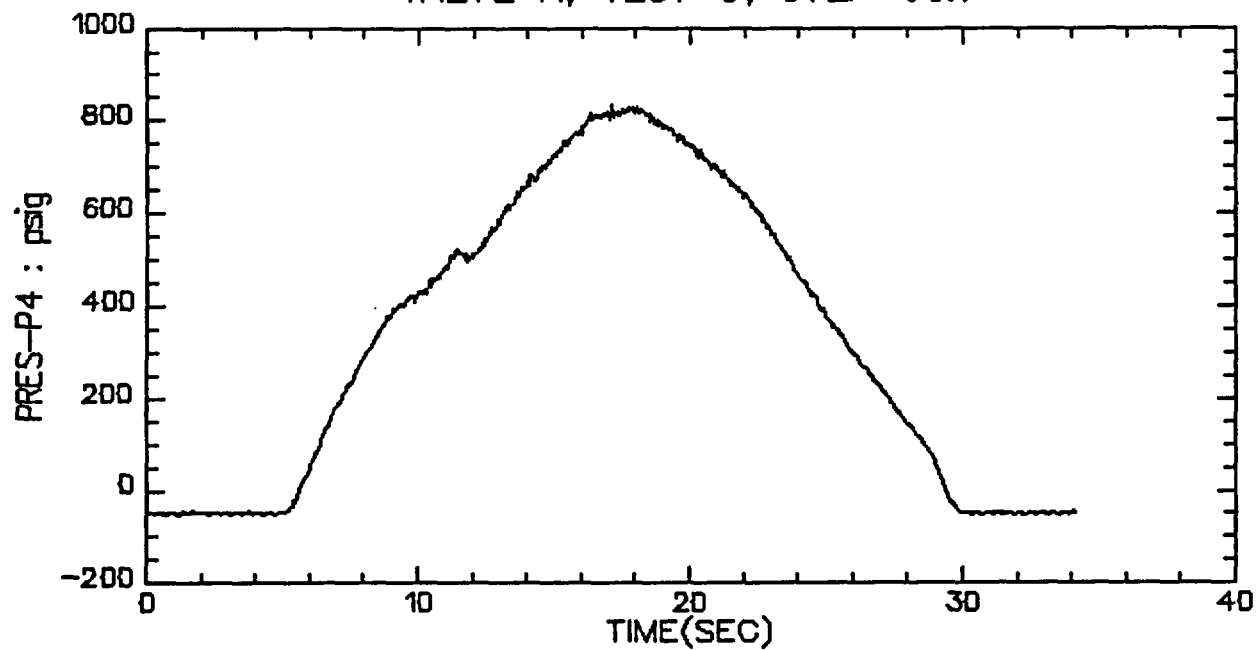

VALVE A, TEST 5, STEP 6&7

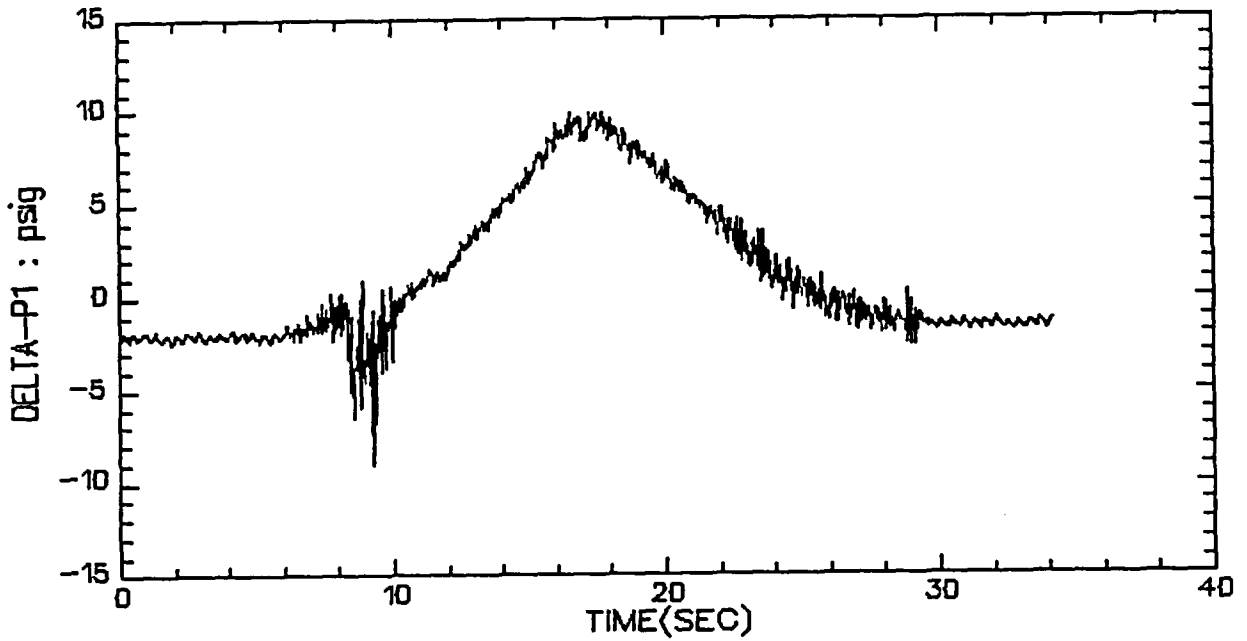

VALVE A, TEST 5, STEP 6&7

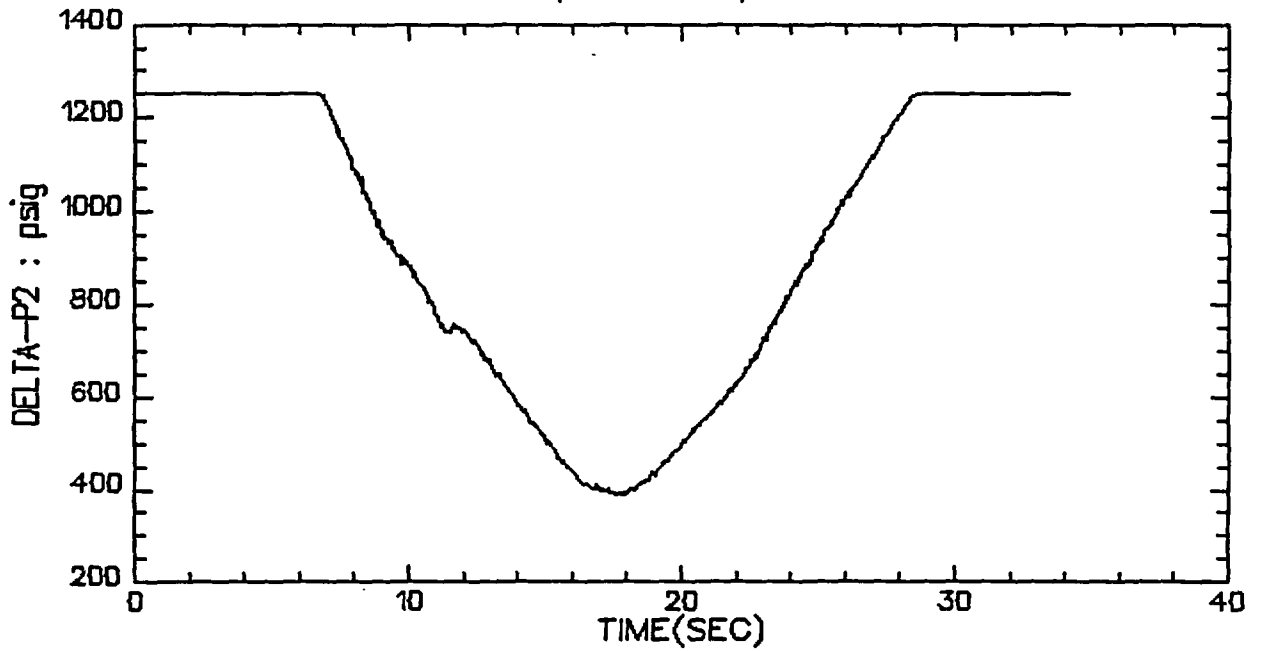

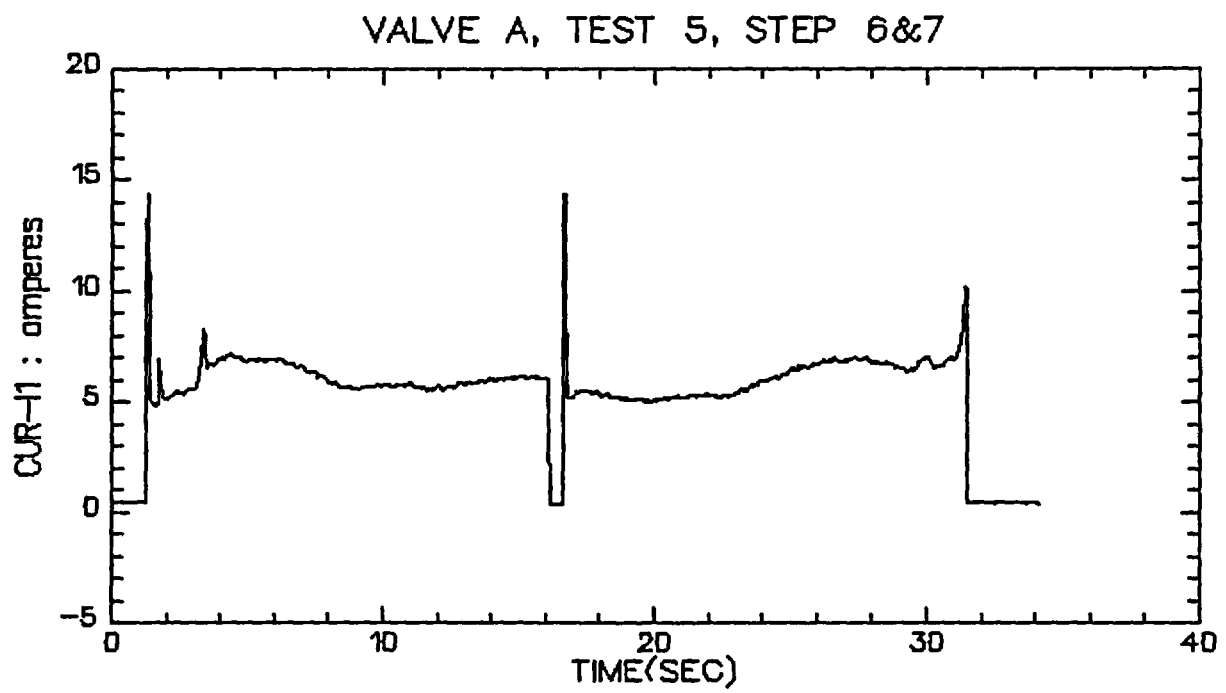
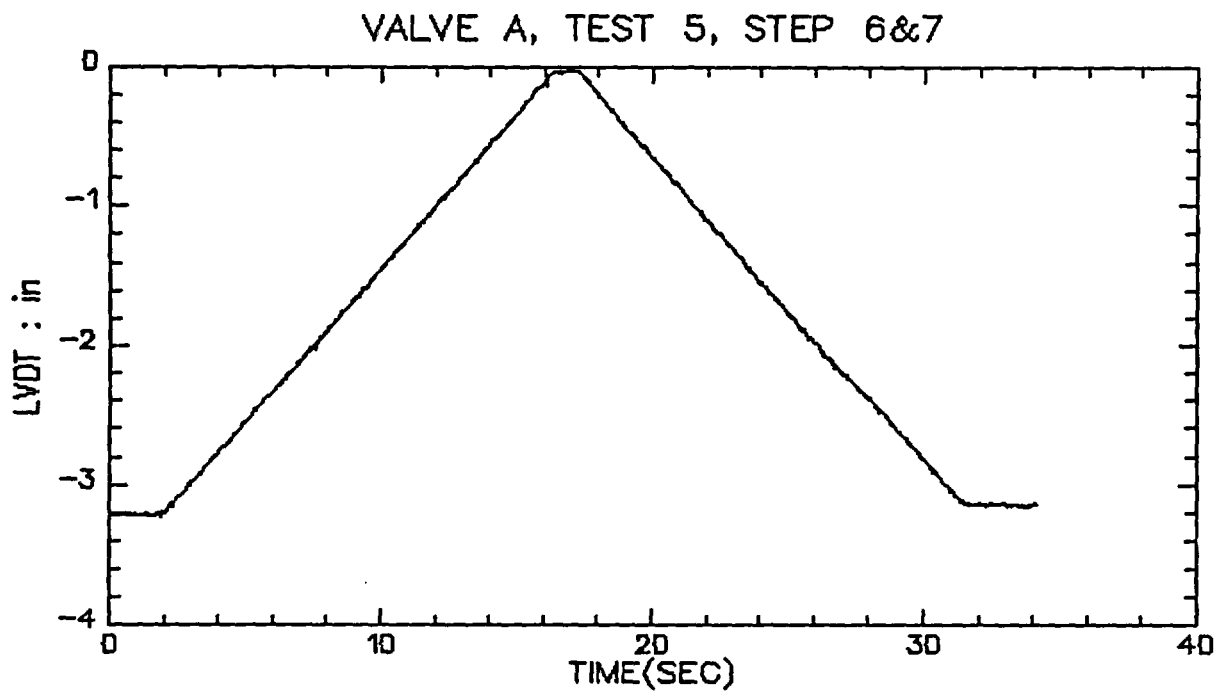

VALVE A, TEST 5, STEP 6&7

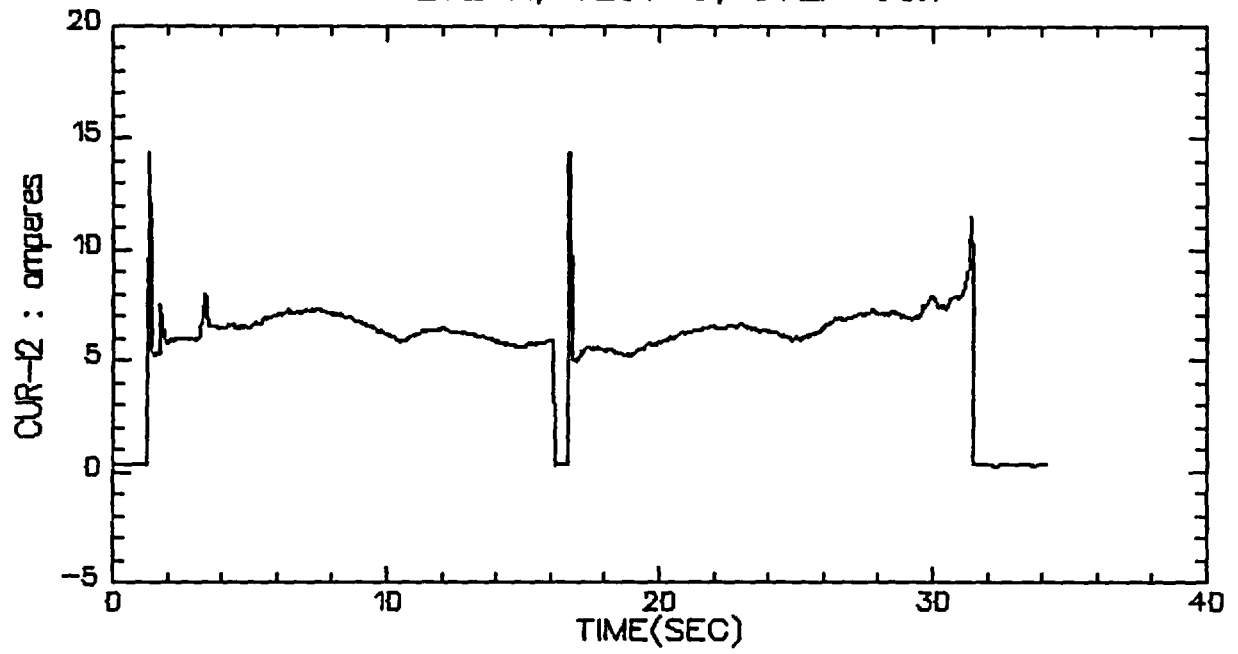

VALVE A, TEST 5, STEP 6&7

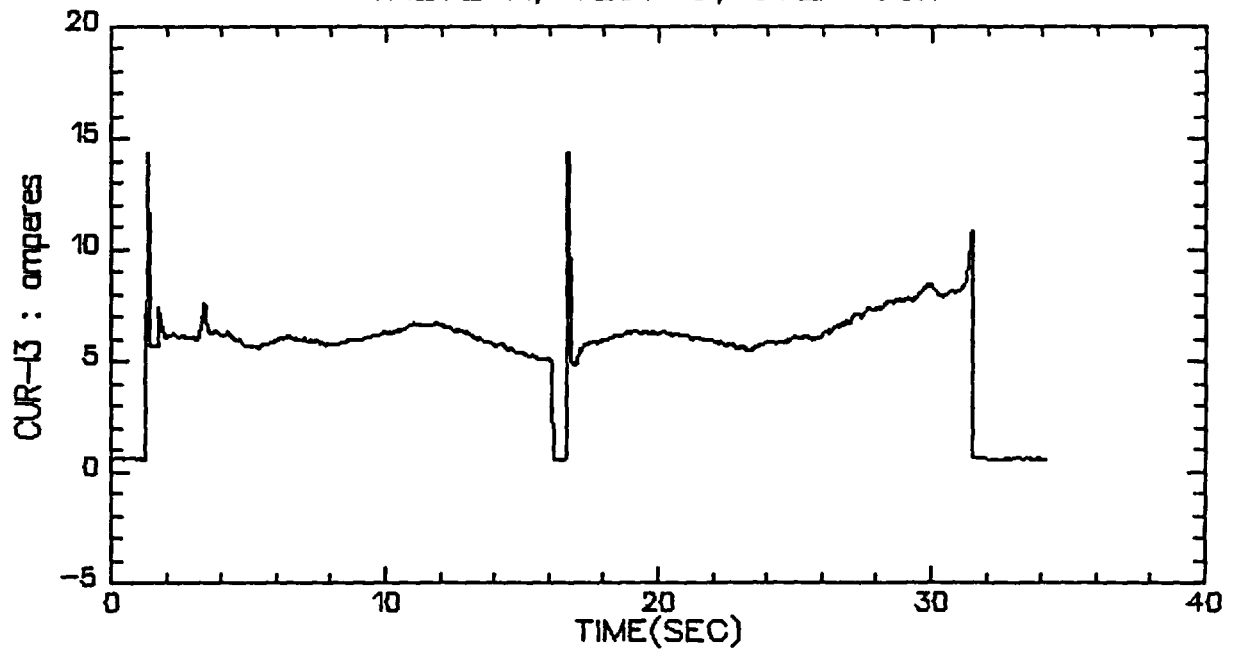

VALVE A, TEST 5, STEP 6&7

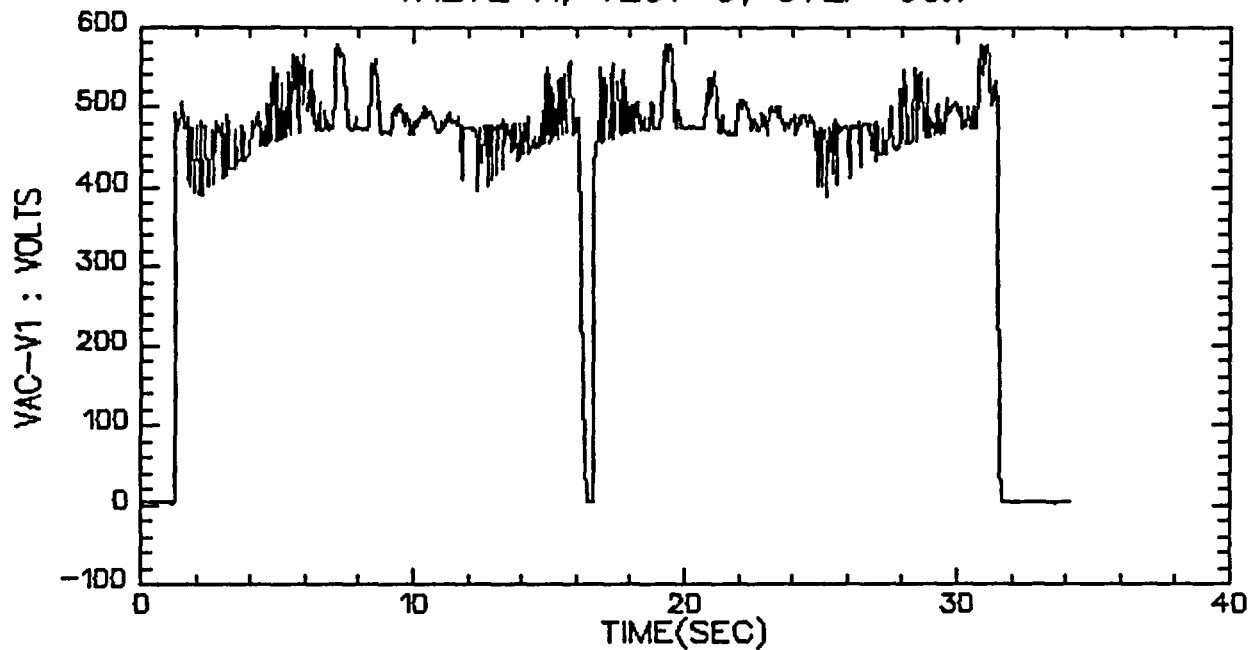

VALVE A, TEST 5, STEP 6&7

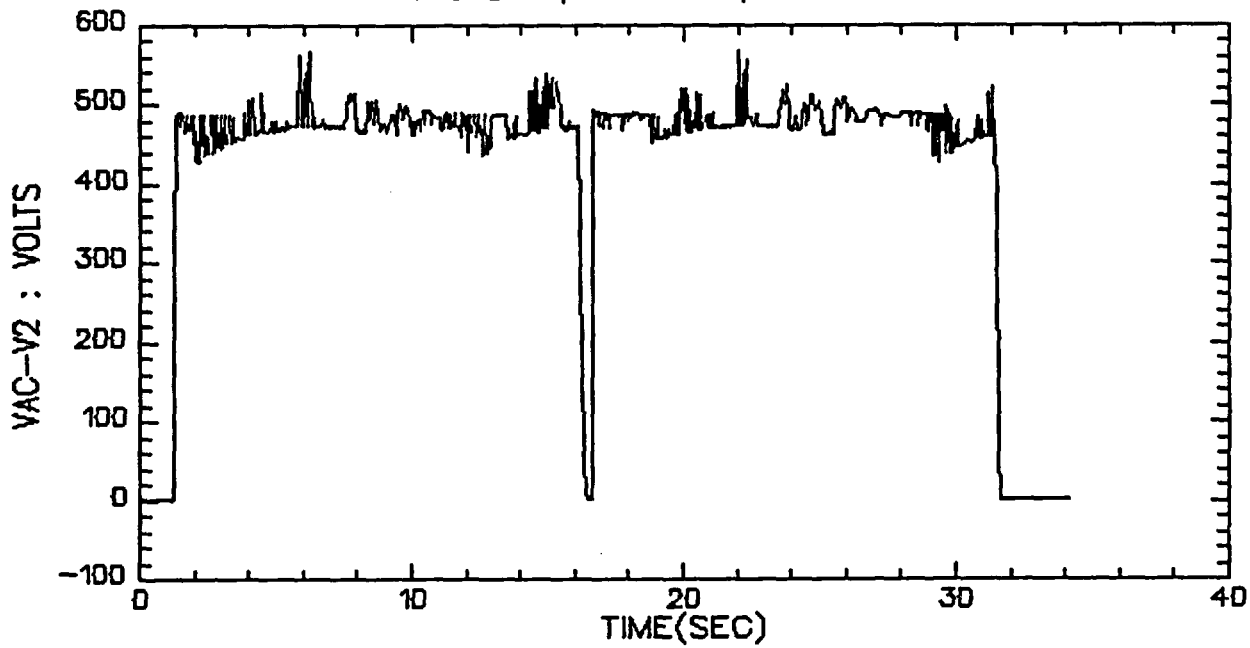

VALVE A, TEST 5, STEP 6&7

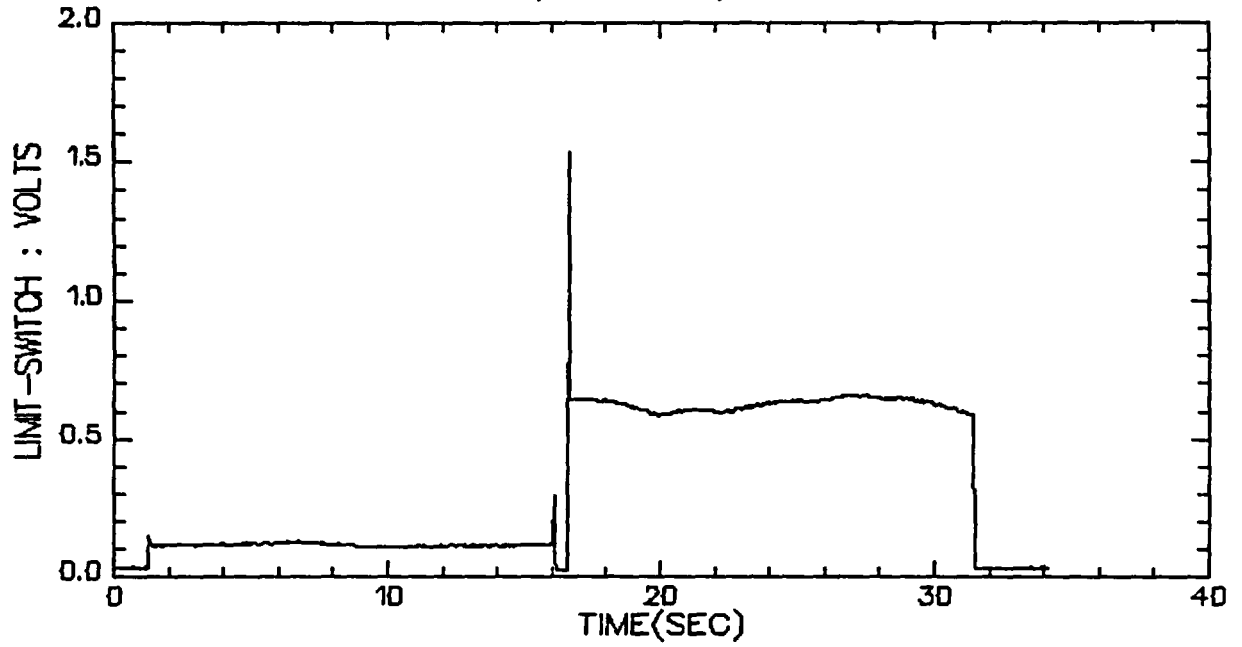

VALVE A, TEST 5, STEP 6&7

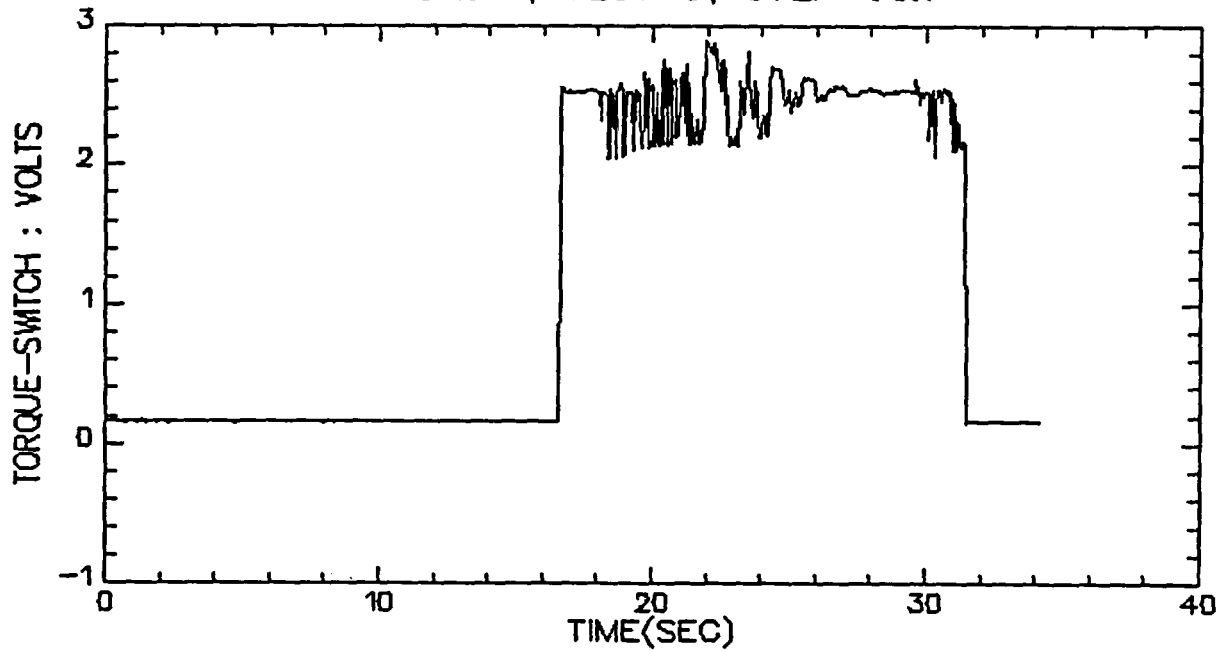

VALVE A, TEST 5, STEP 6&7

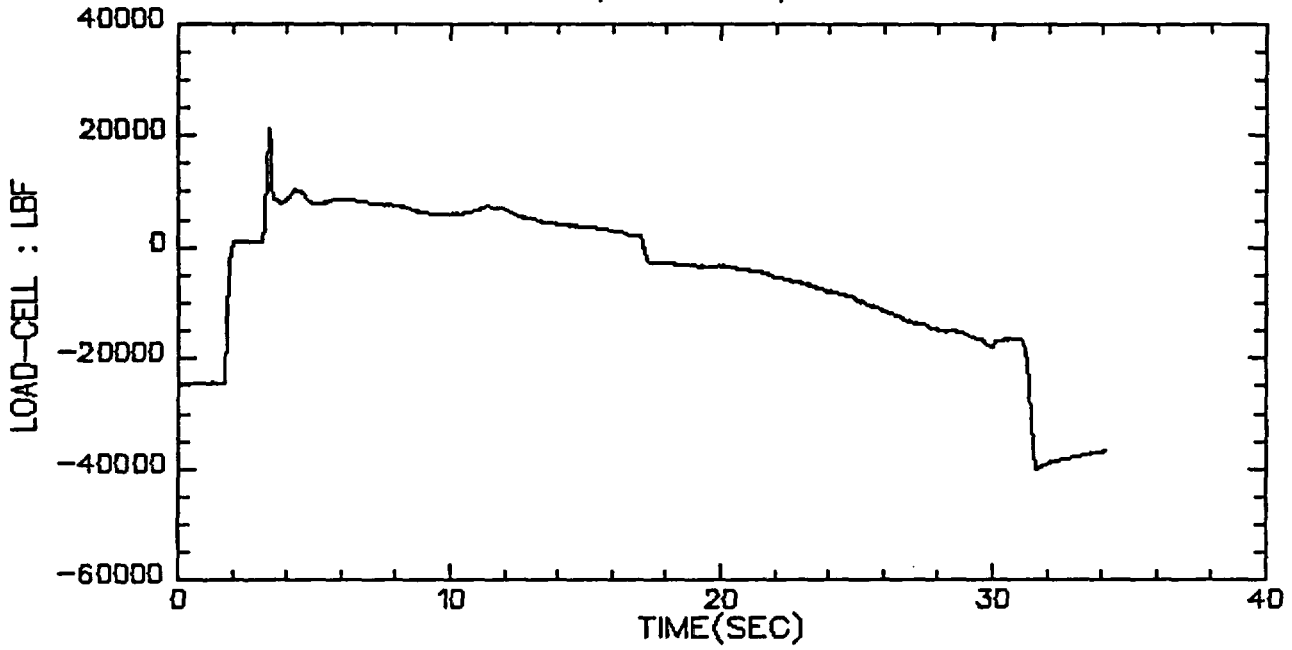

VALVE A, TEST 5, STEP 8&9

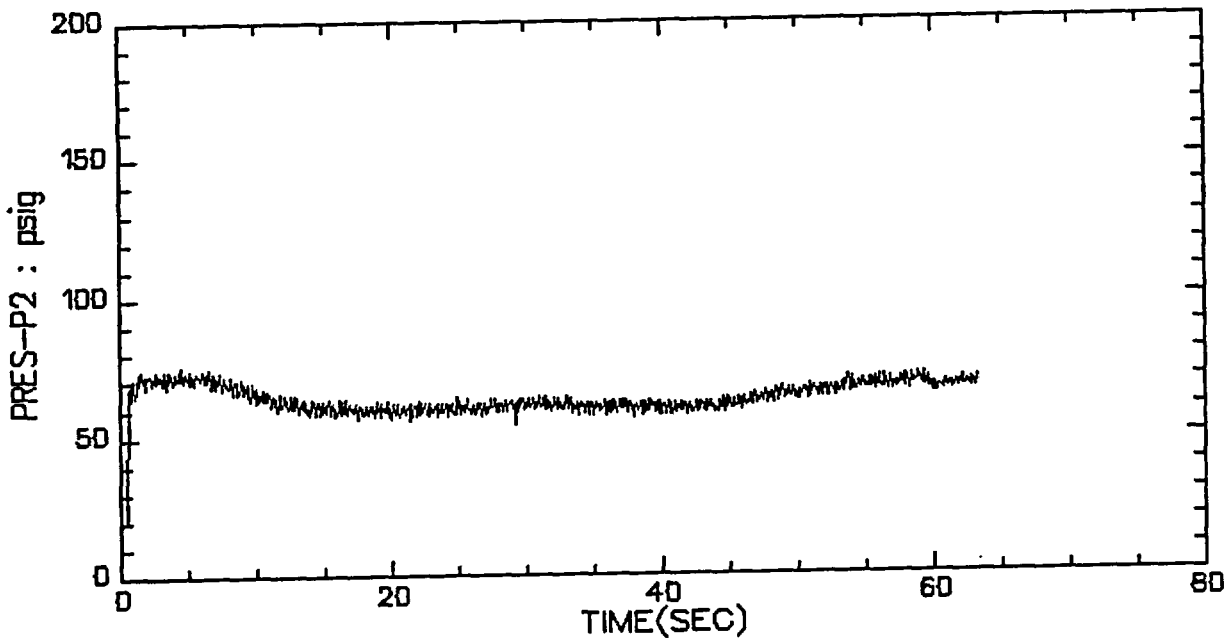

VALVE A, TEST 5, STEP 8&9

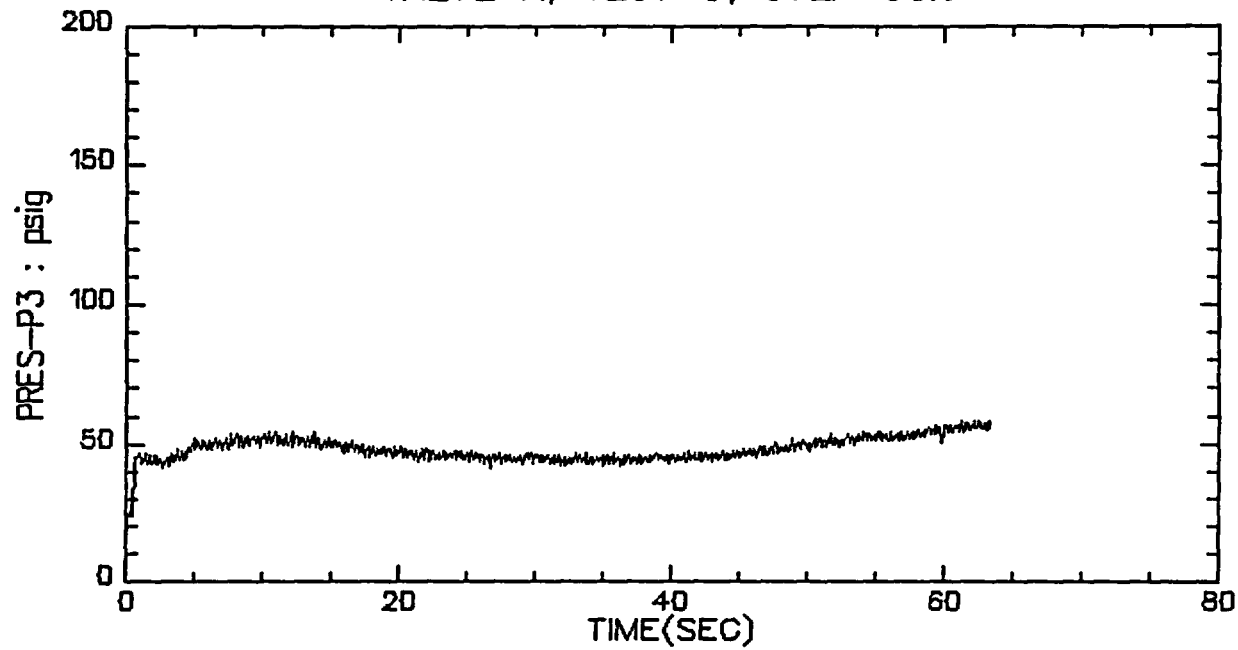

VALVE A, TEST 5, STEP 8&9

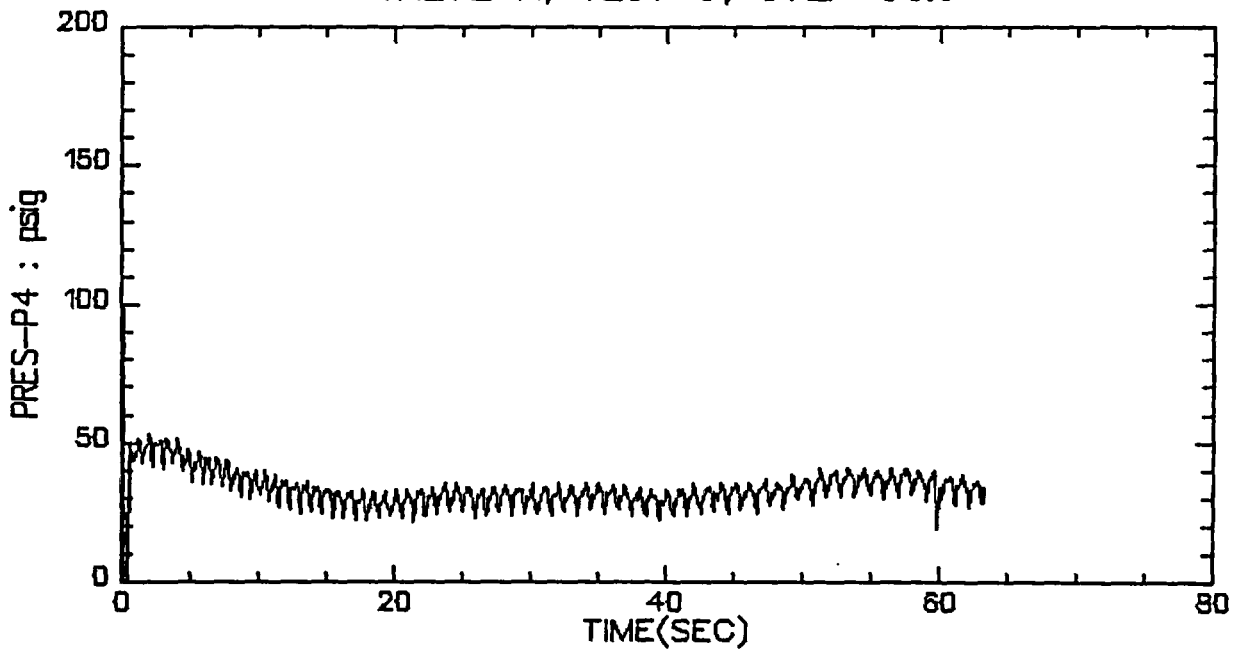

VALVE A, TEST 5, STEP 8&9

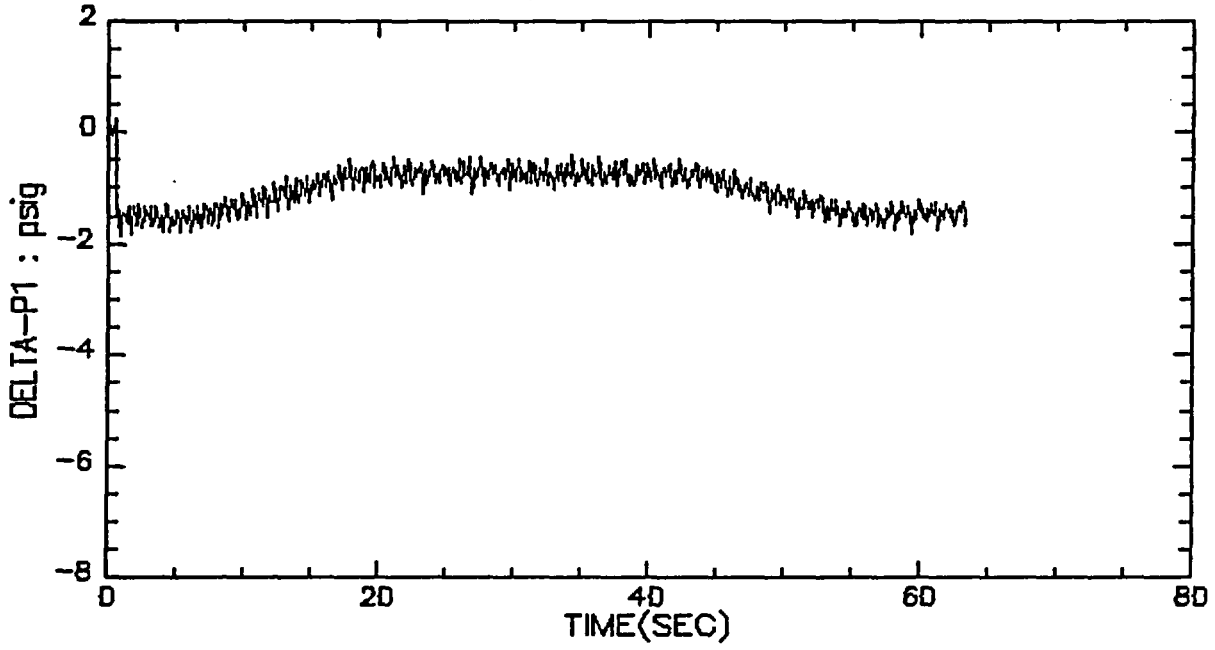

VALVE A, TEST 5, STEP 8&9

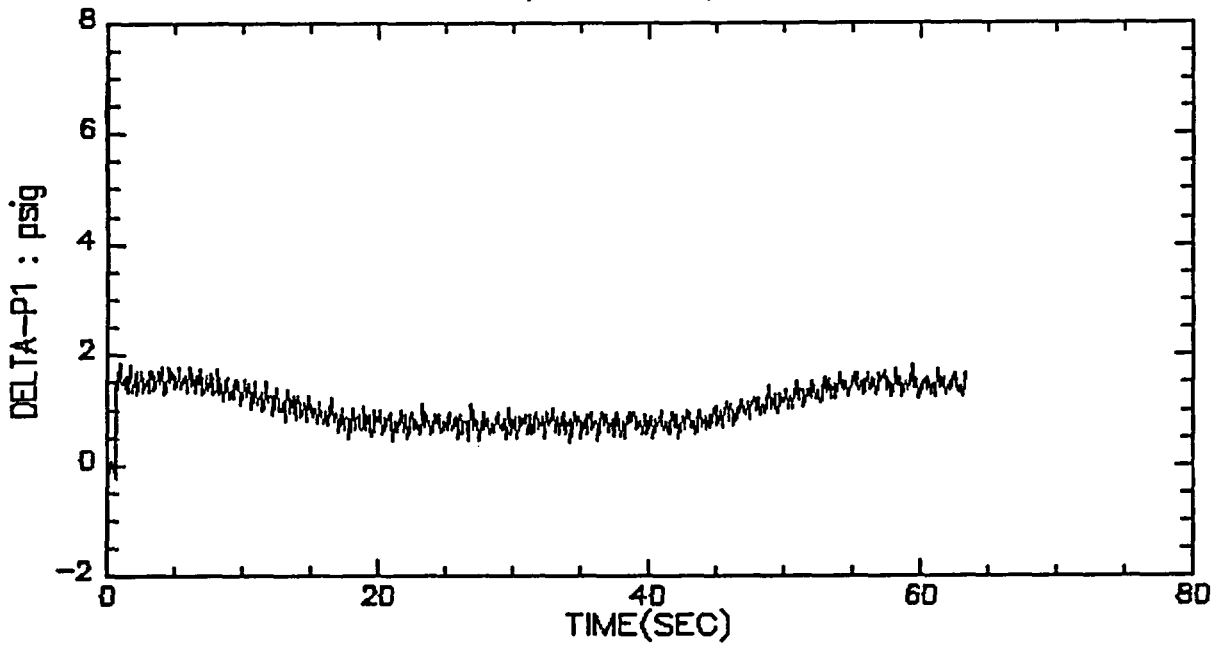

VALVE A, TEST 5, STEP 8&9

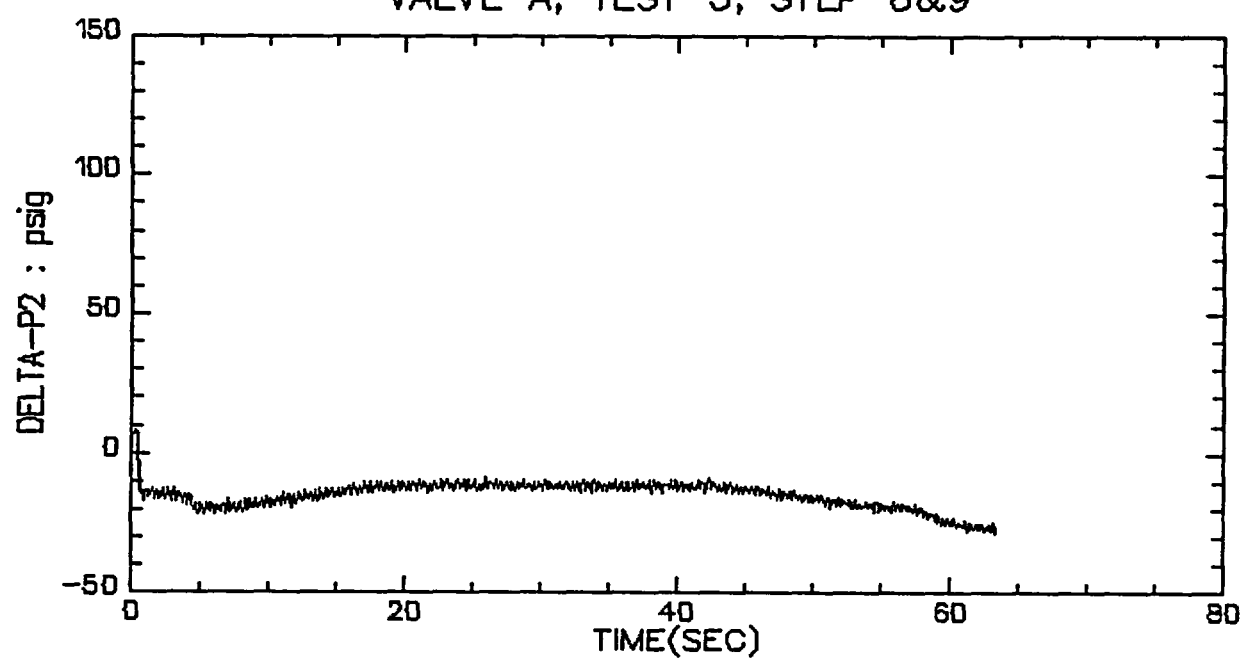

VALVE A, TEST 5, STEP 8&9

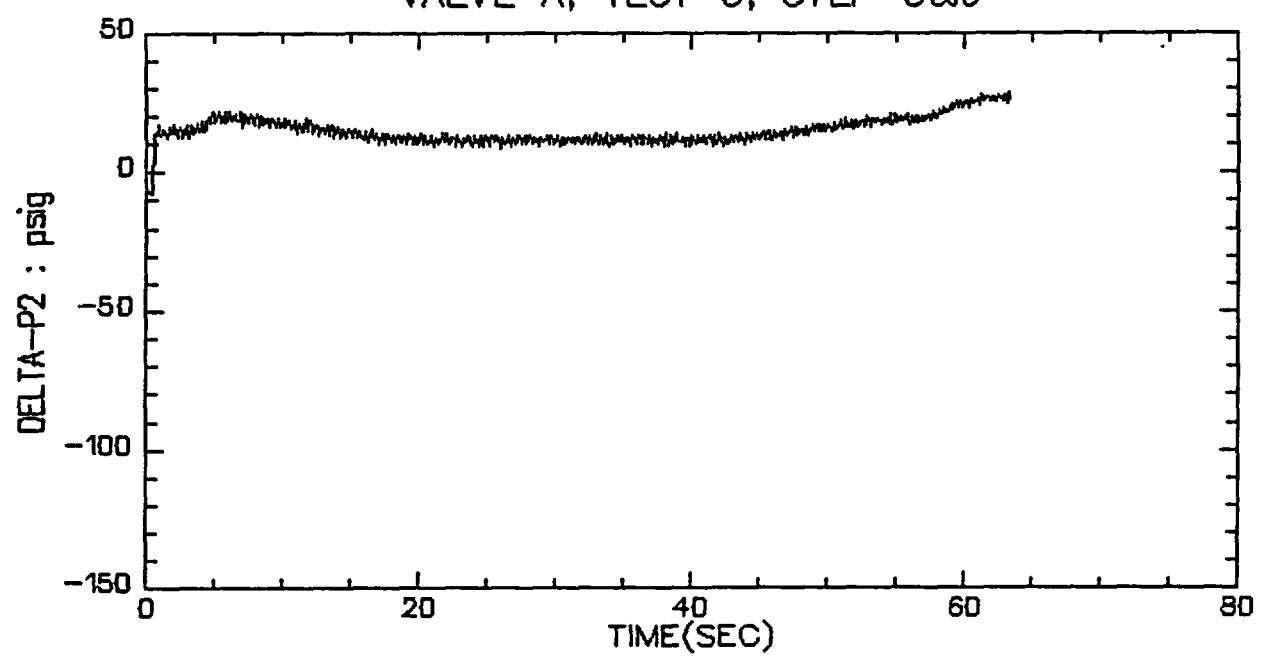

VALVE A, TEST 5, STEP 8&9

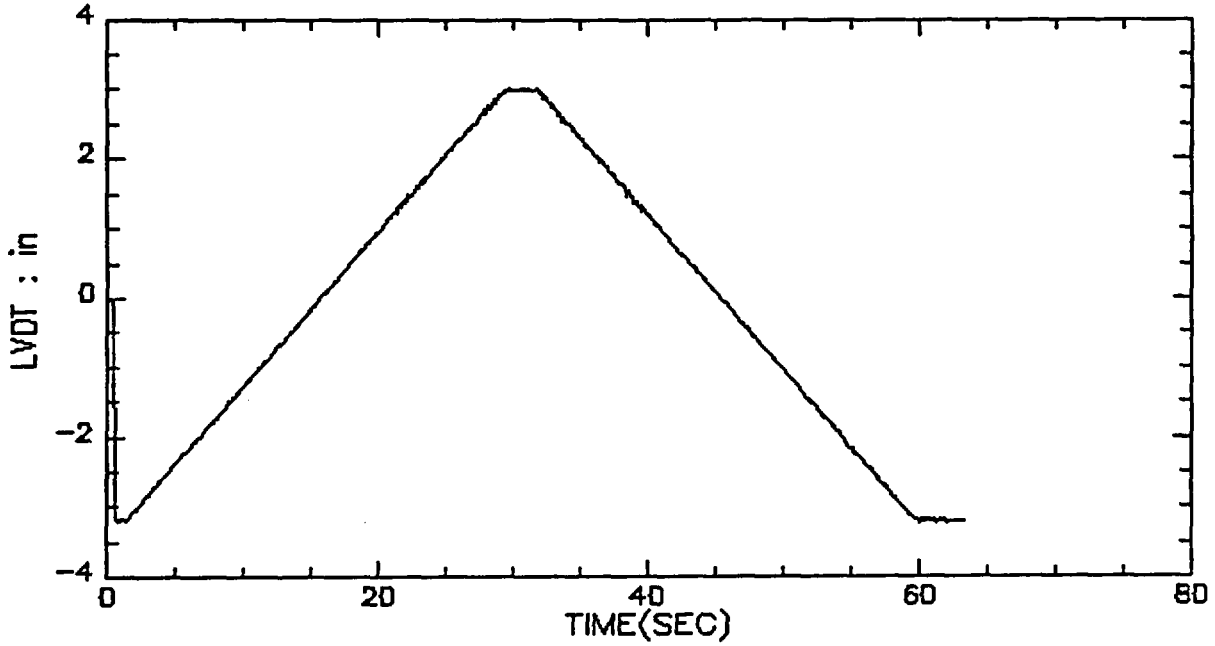

VALVE A, TEST 5, STEP 8&9

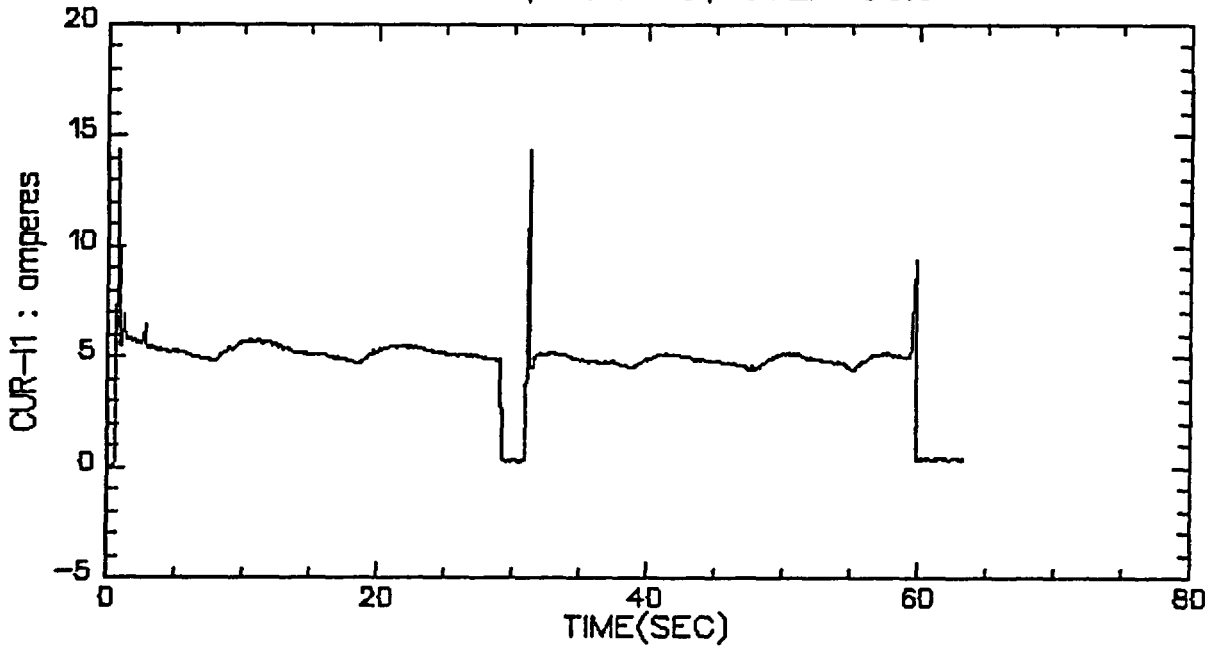

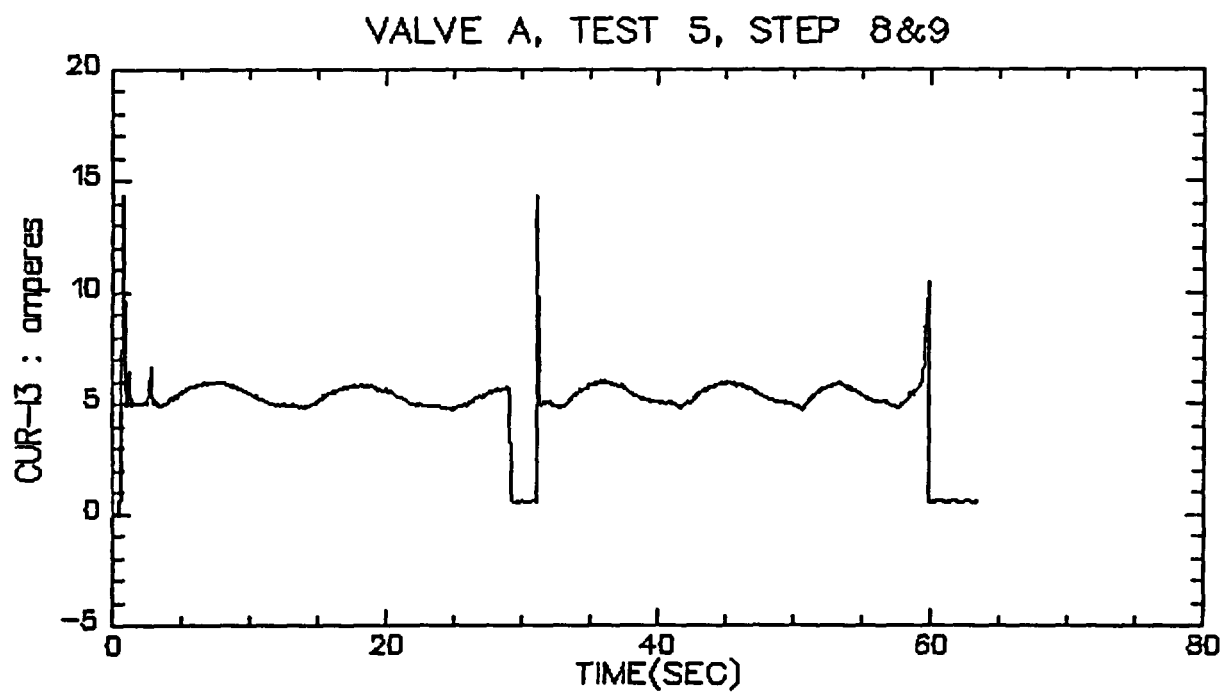
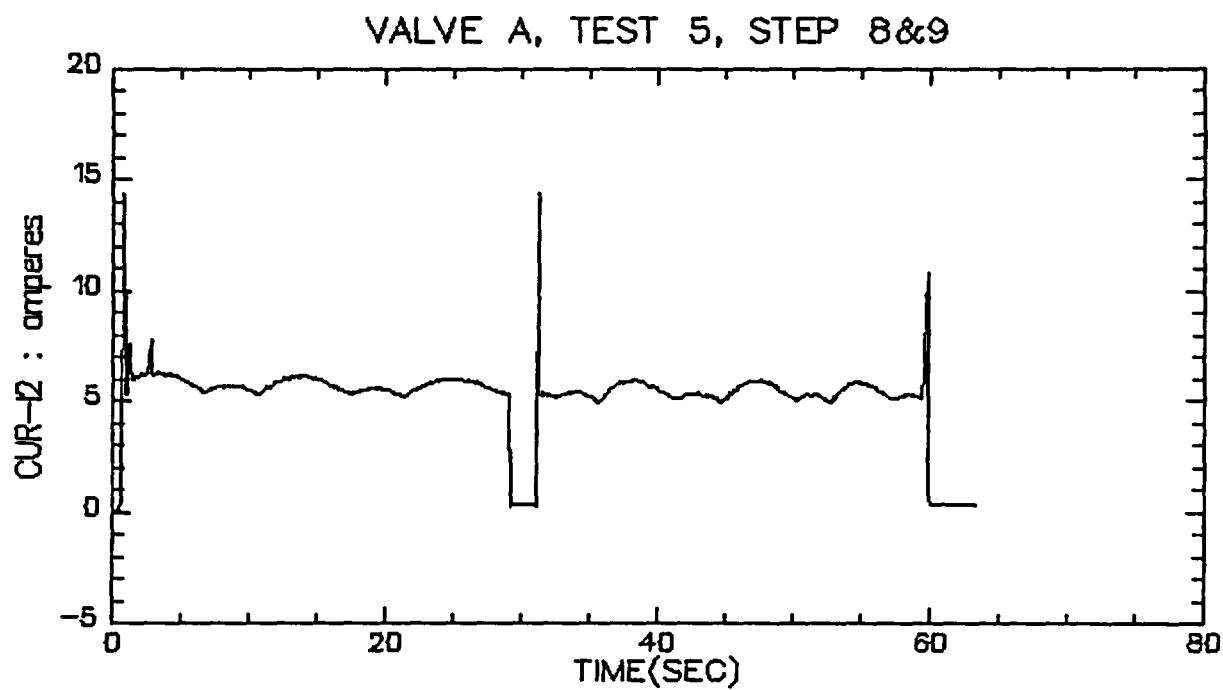

VALVE A, TEST 5, STEP 8&9

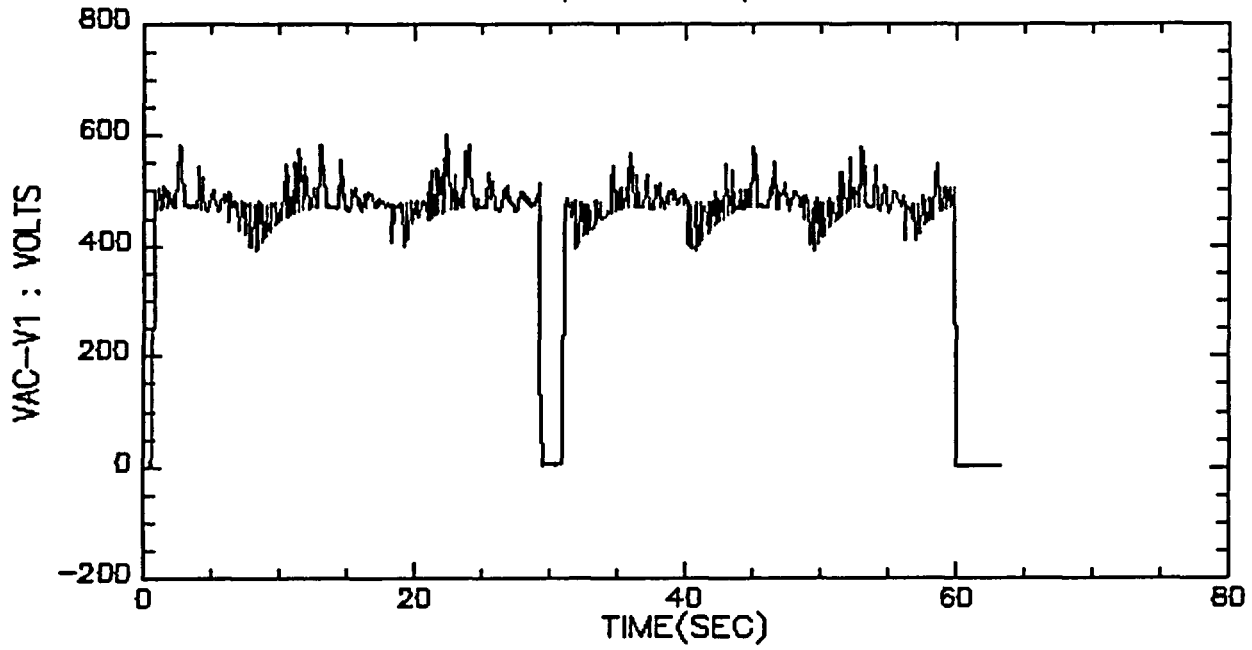

VALVE A, TEST 5, STEP 8&9

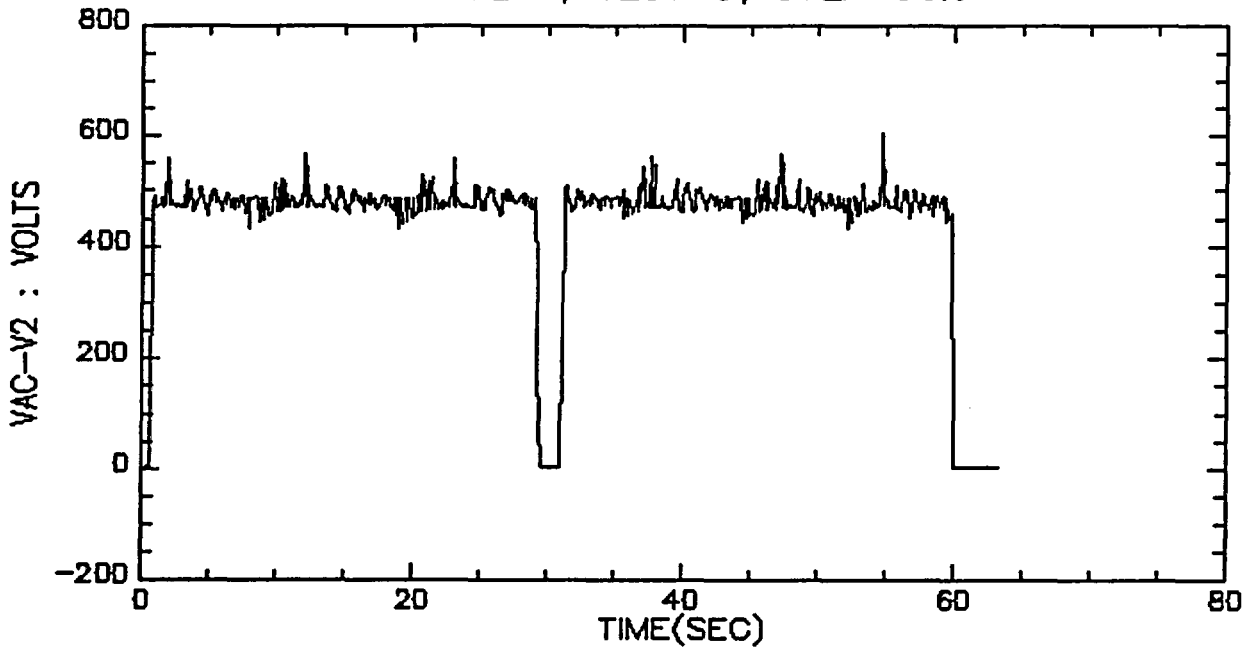

VALVE A, TEST 5, STEP 8&9

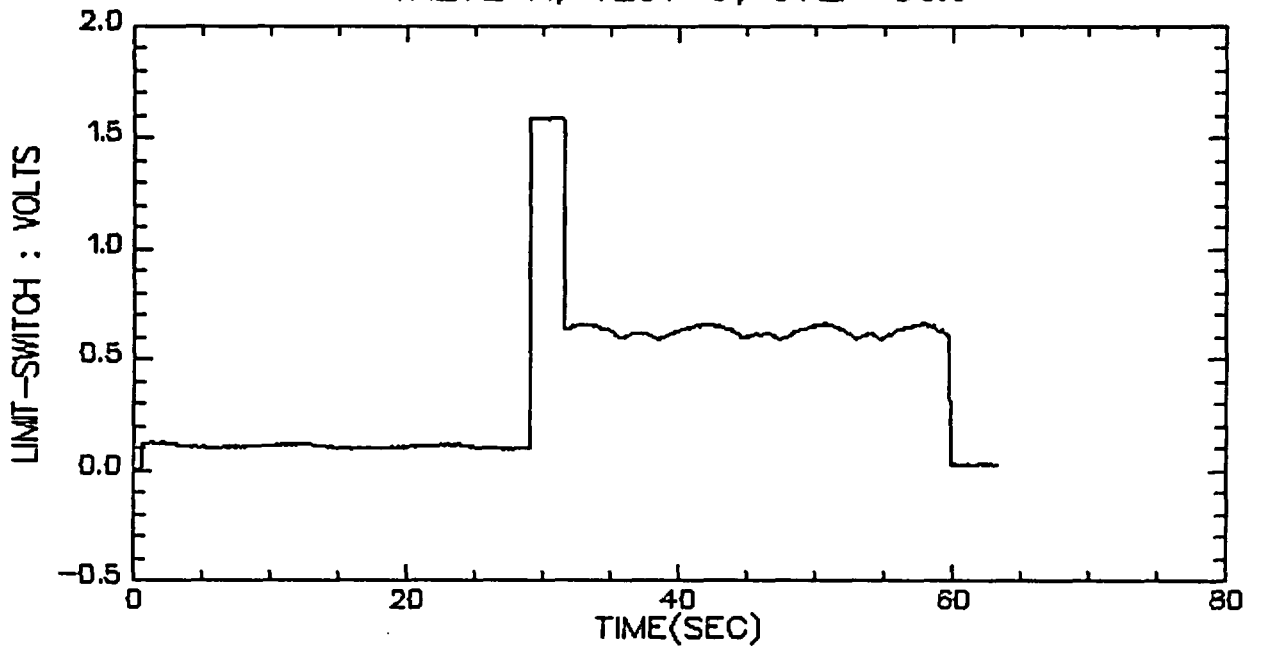

VALVE A, TEST 5, STEP 8&9

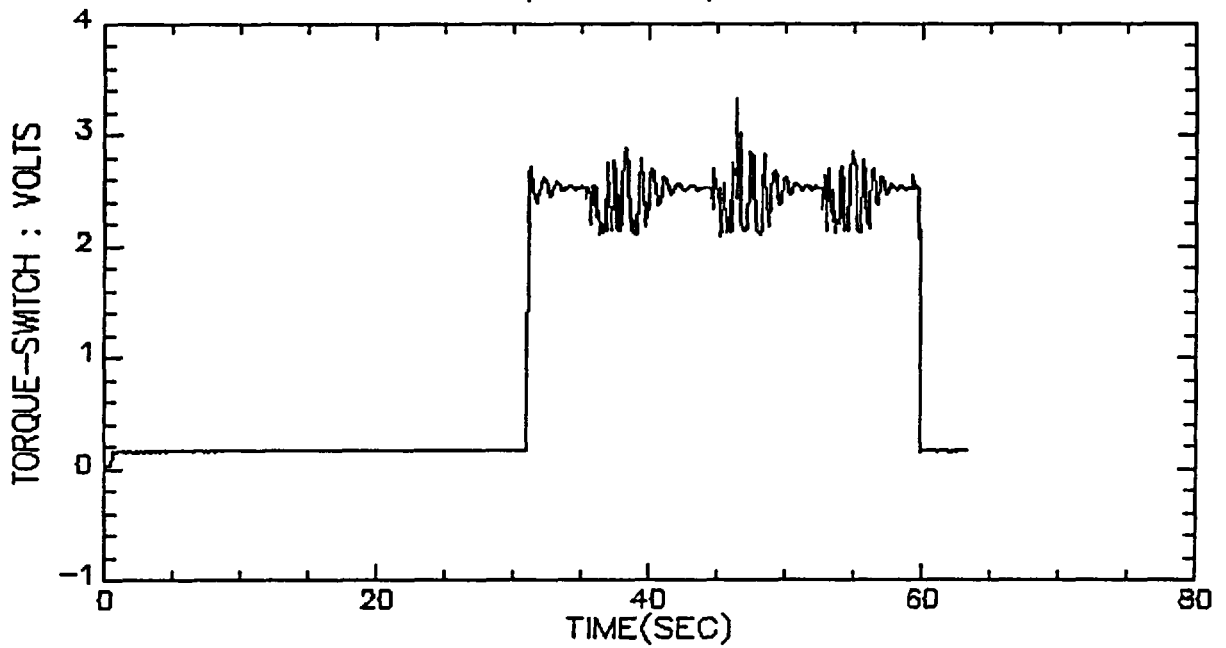

VALVE A, TEST 6, STEP 1

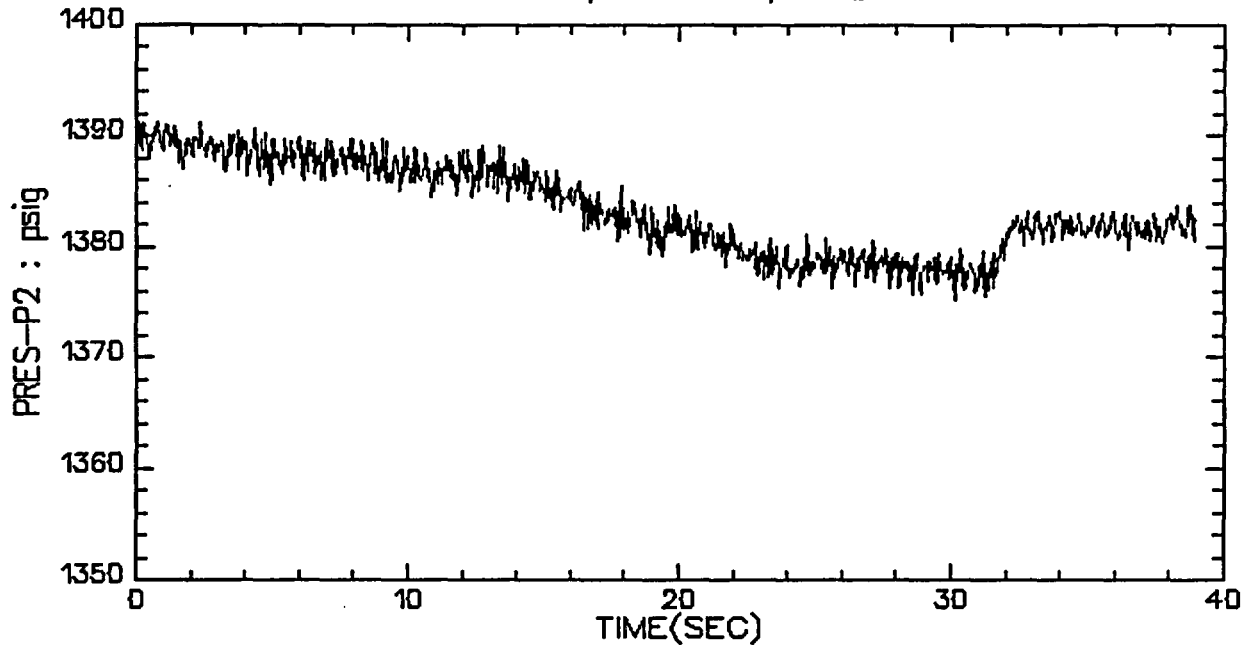

VALVE A, TEST 6, STEP 1

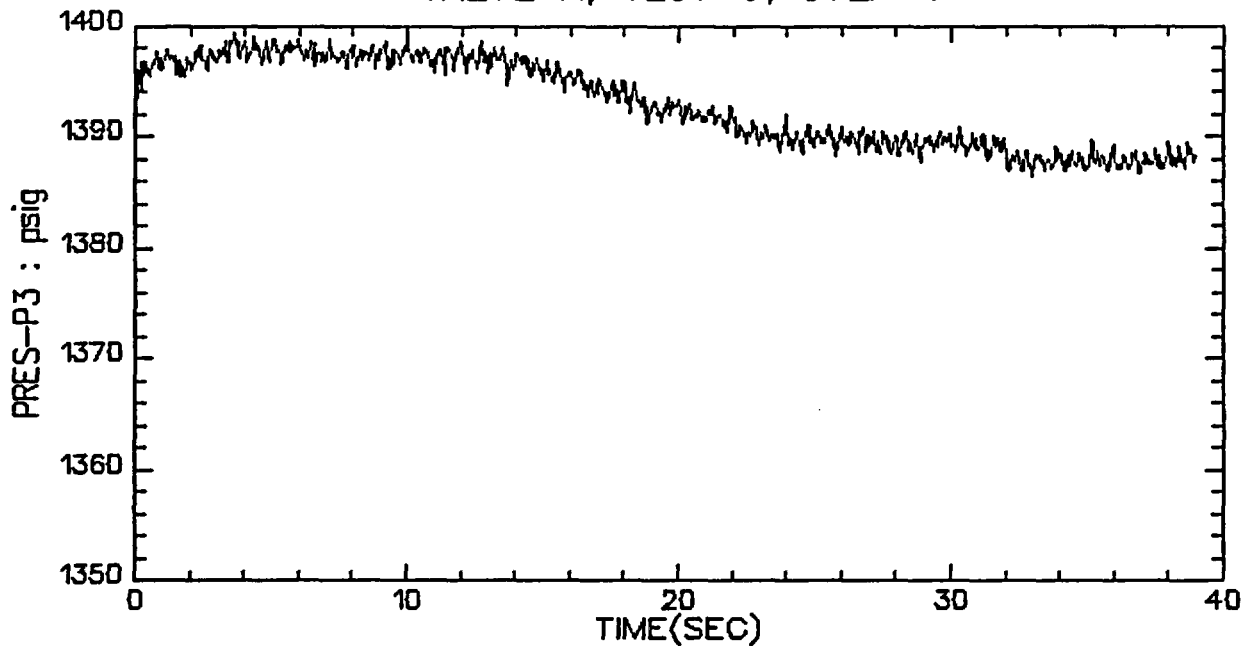

VALVE A, TEST 6, STEP 1

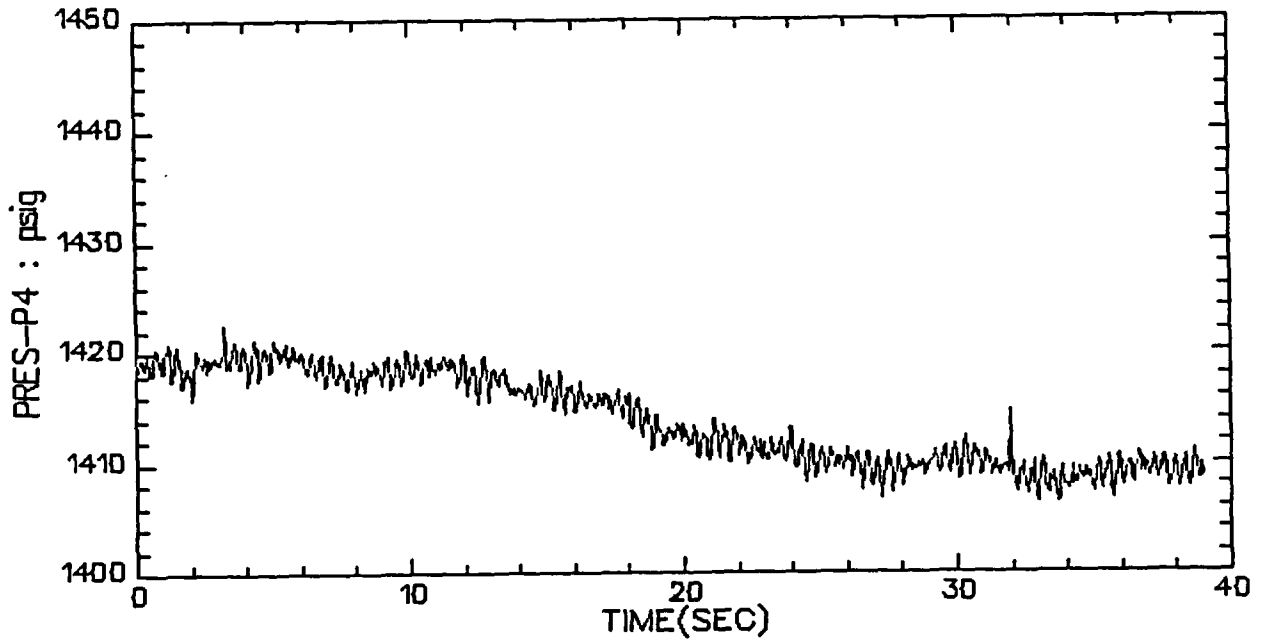

VALVE A, TEST 6 STEP 1

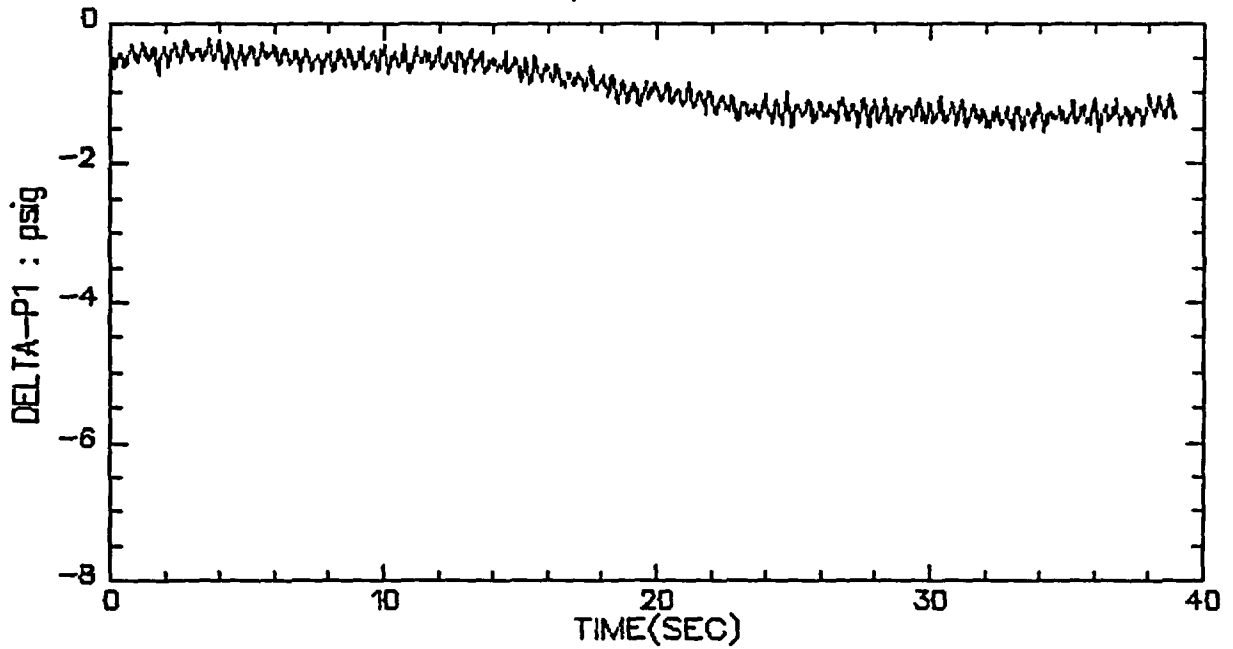

VALVE A, TEST 6, STEP 1

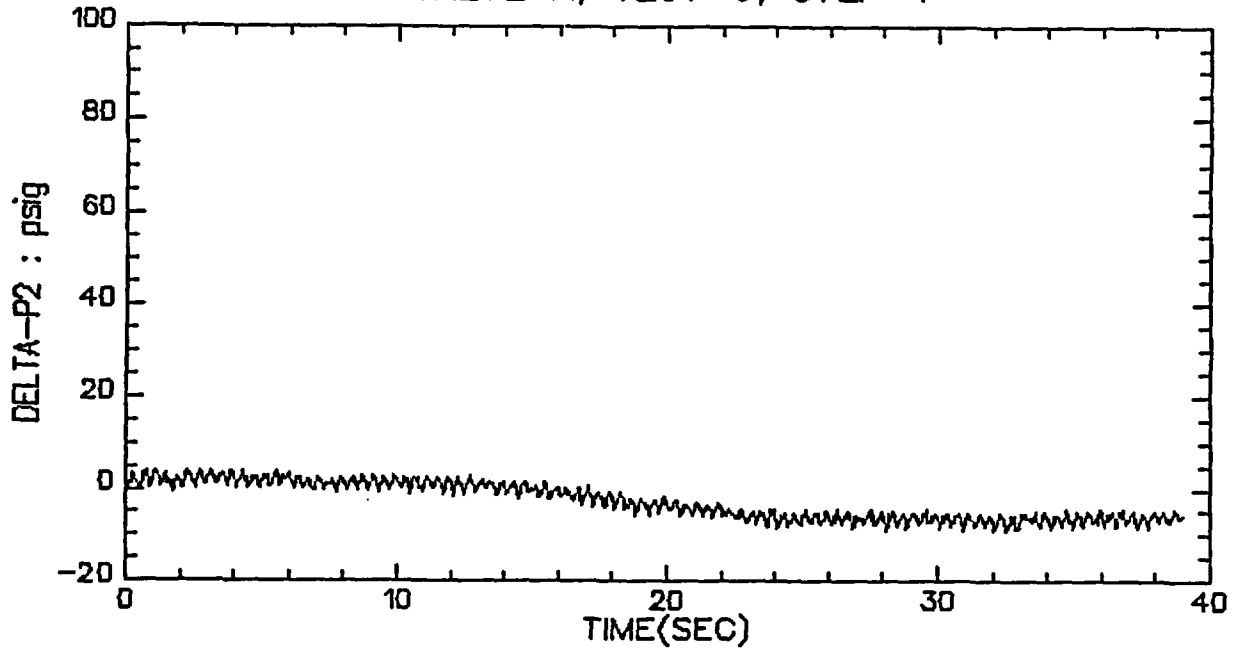

VALVE A, TEST 6, STEP 1

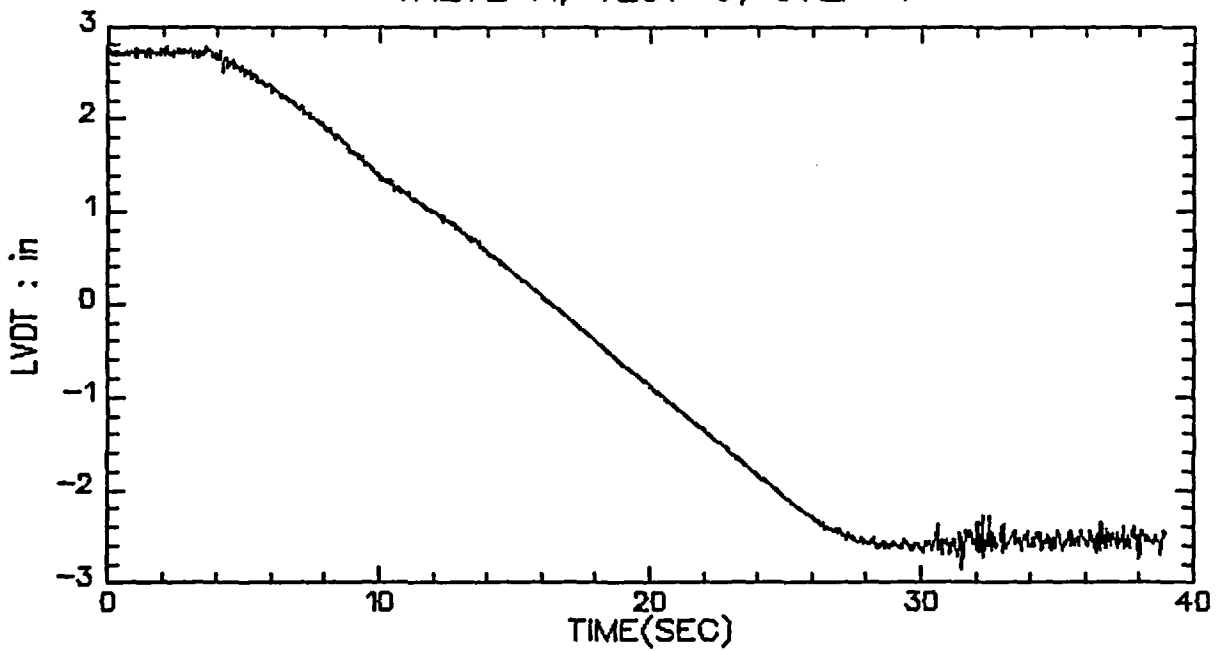

VALVE A, TEST 6, STEP 1

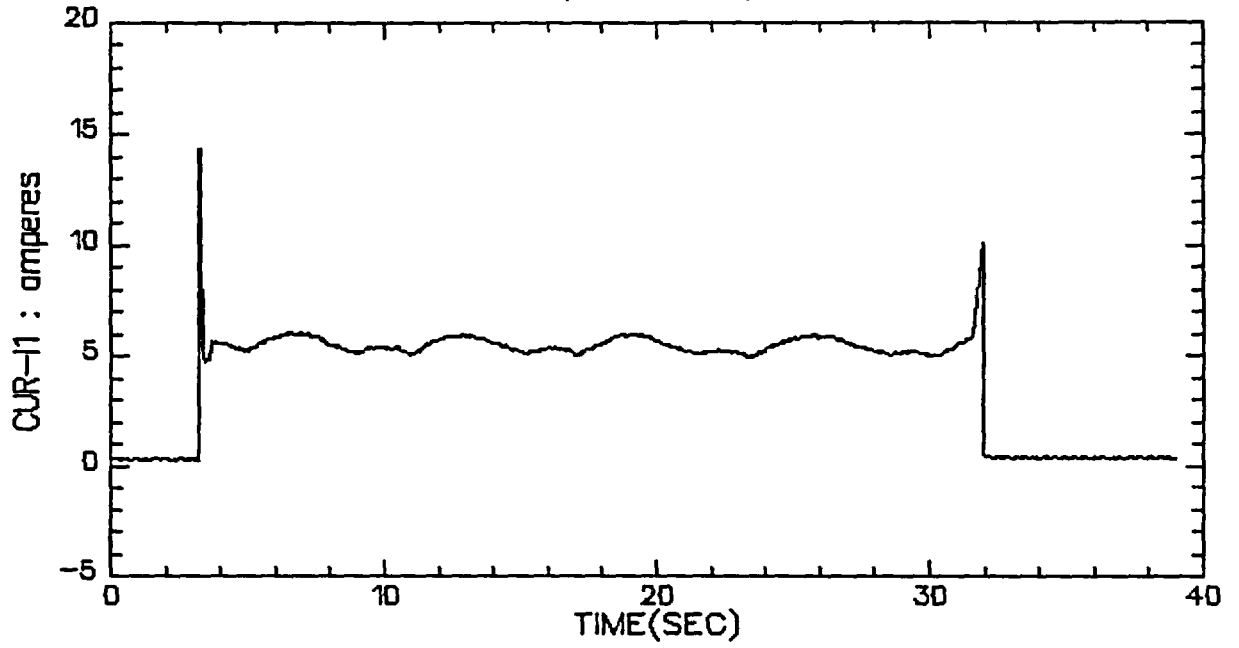

VALVE A, TEST 6, STEP 1

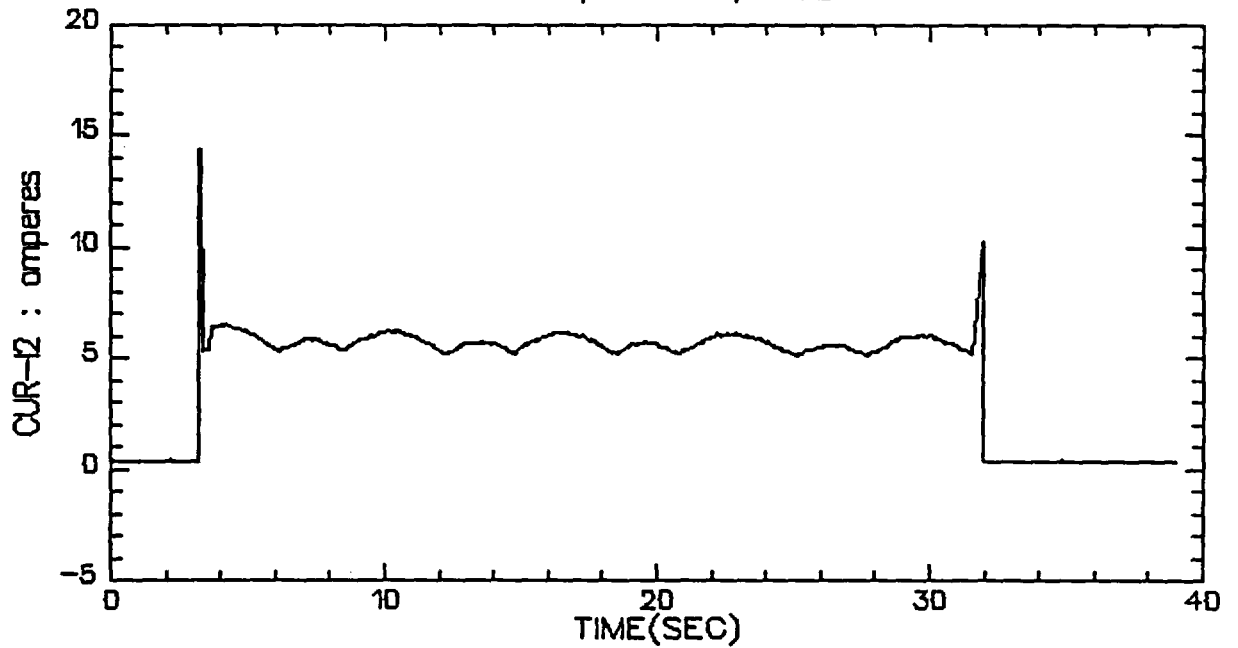

VALVE A, TEST 6, STEP 1

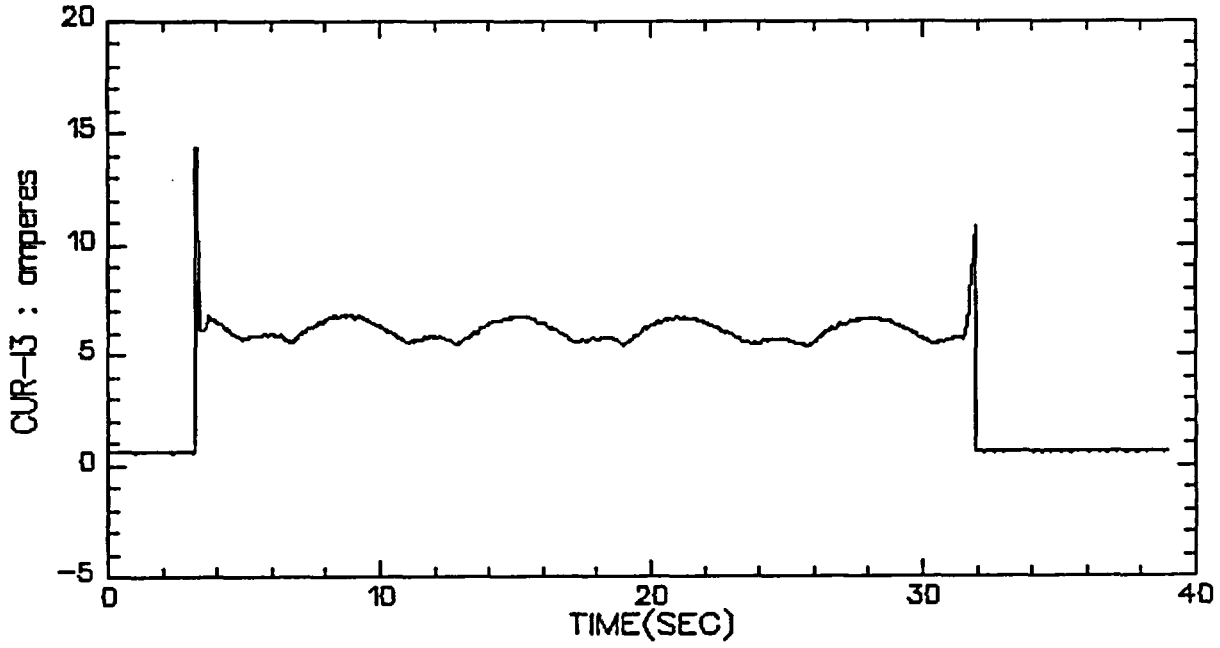

VALVE A, TEST 6, STEP 1

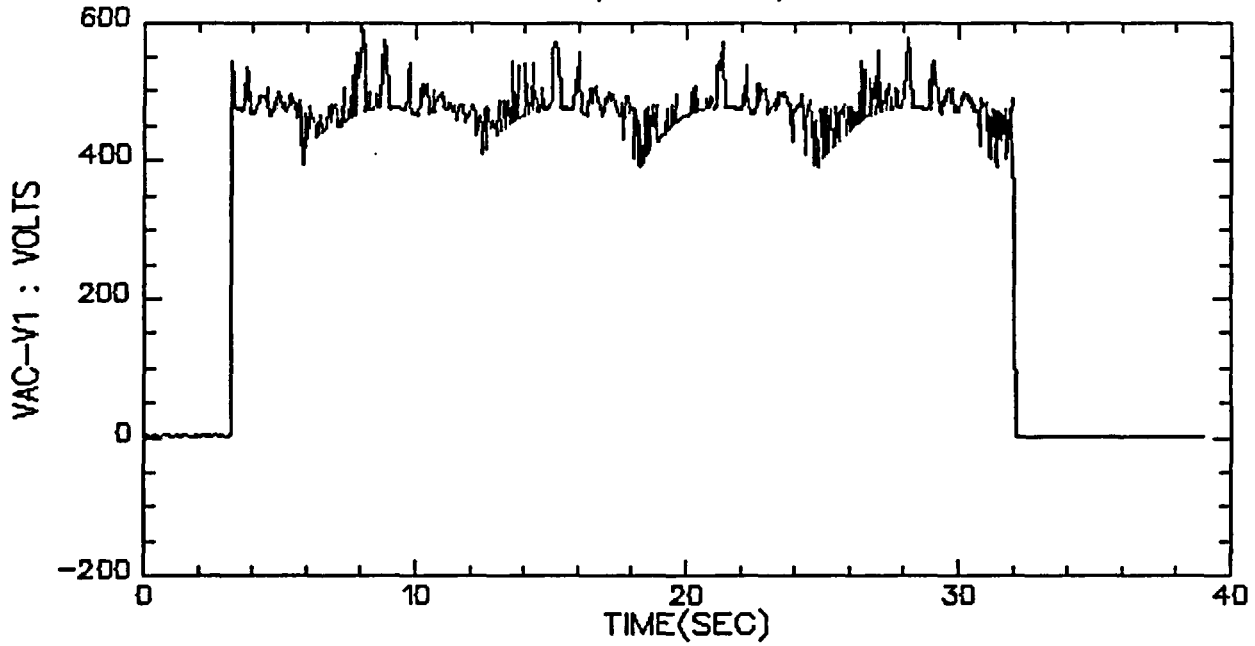

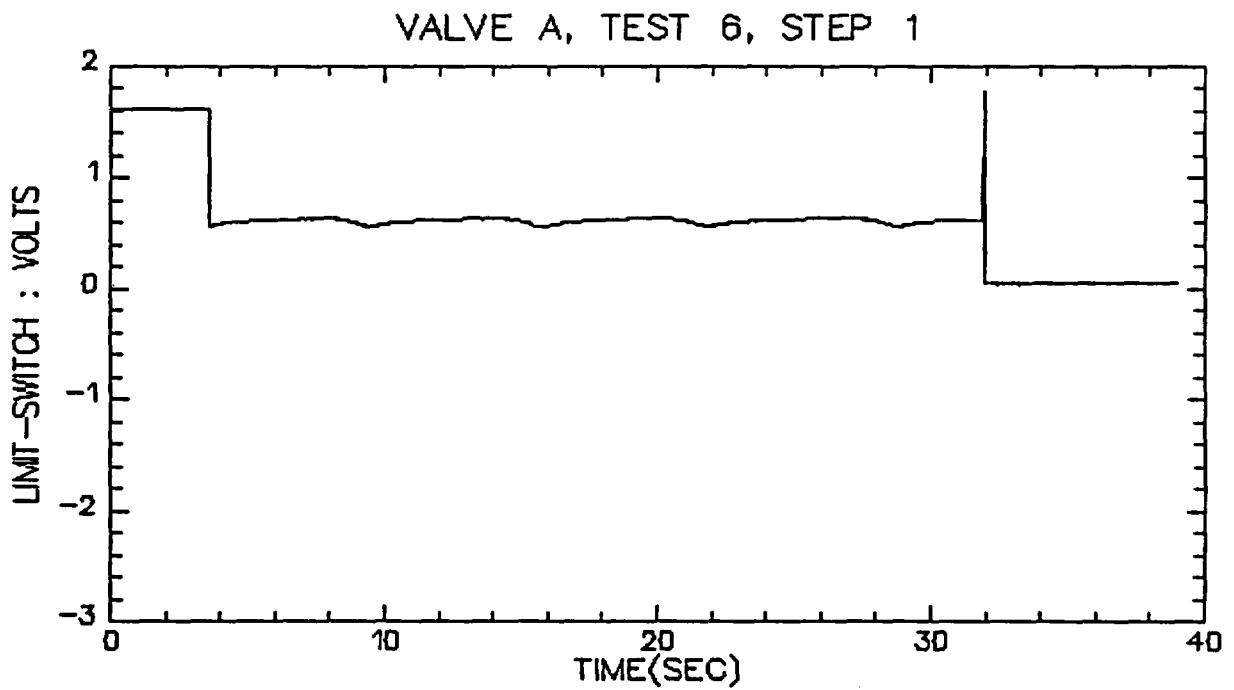
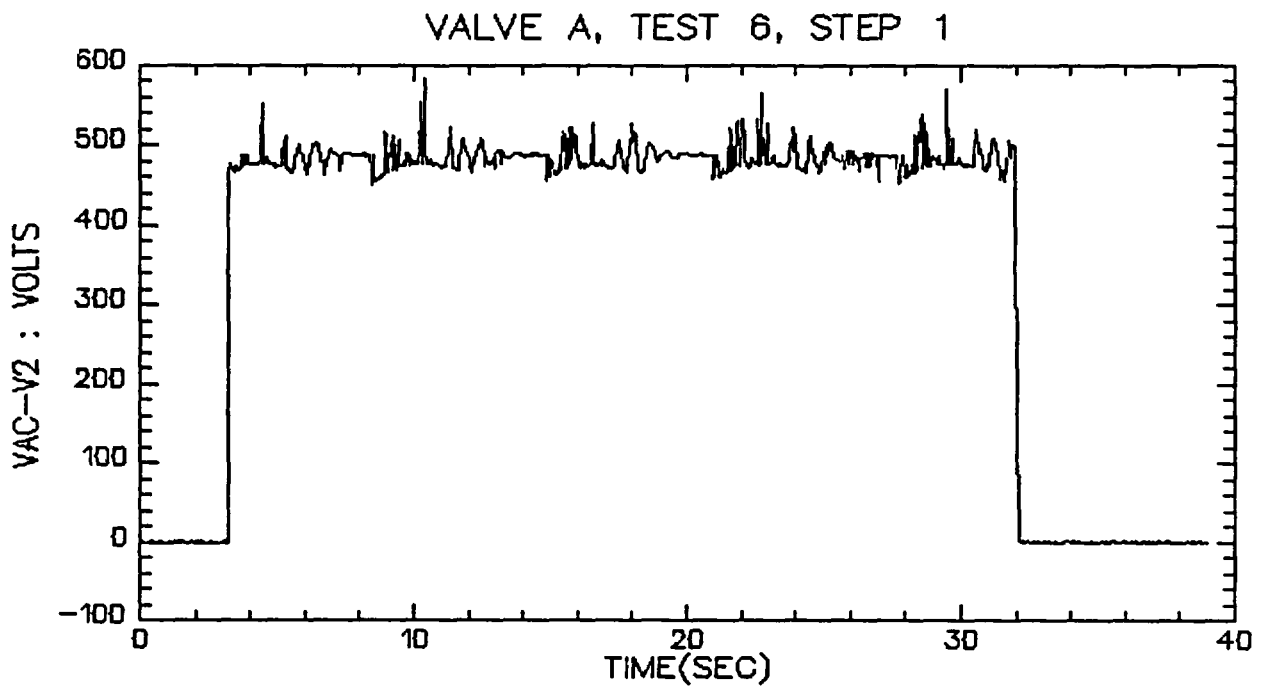

VALVE A, TEST 6, STEP 1

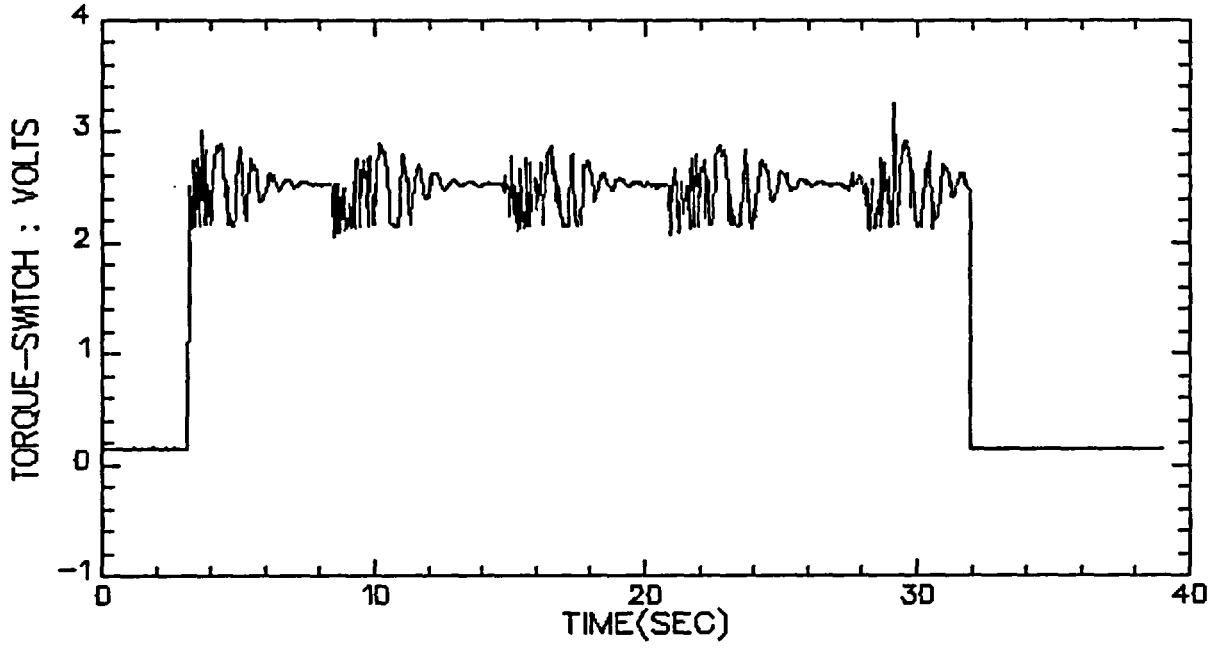

VALVE A, TEST 6, STEP 1

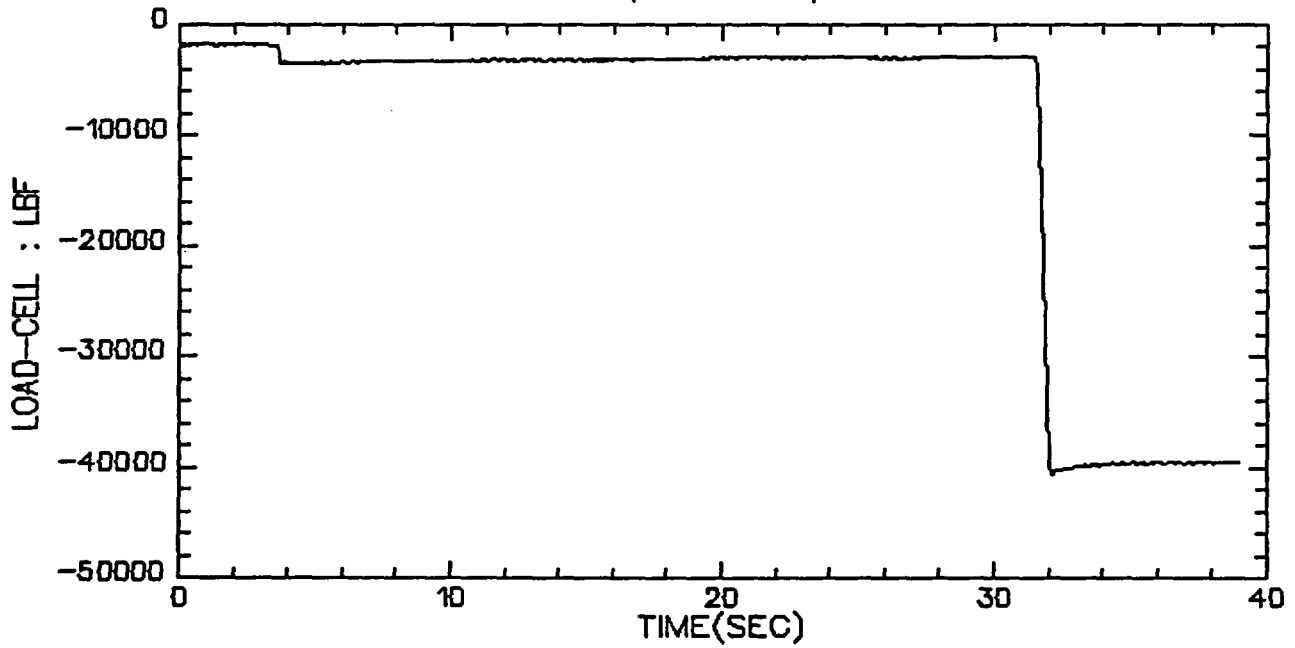

VALVE A, TEST 6, STEP 2

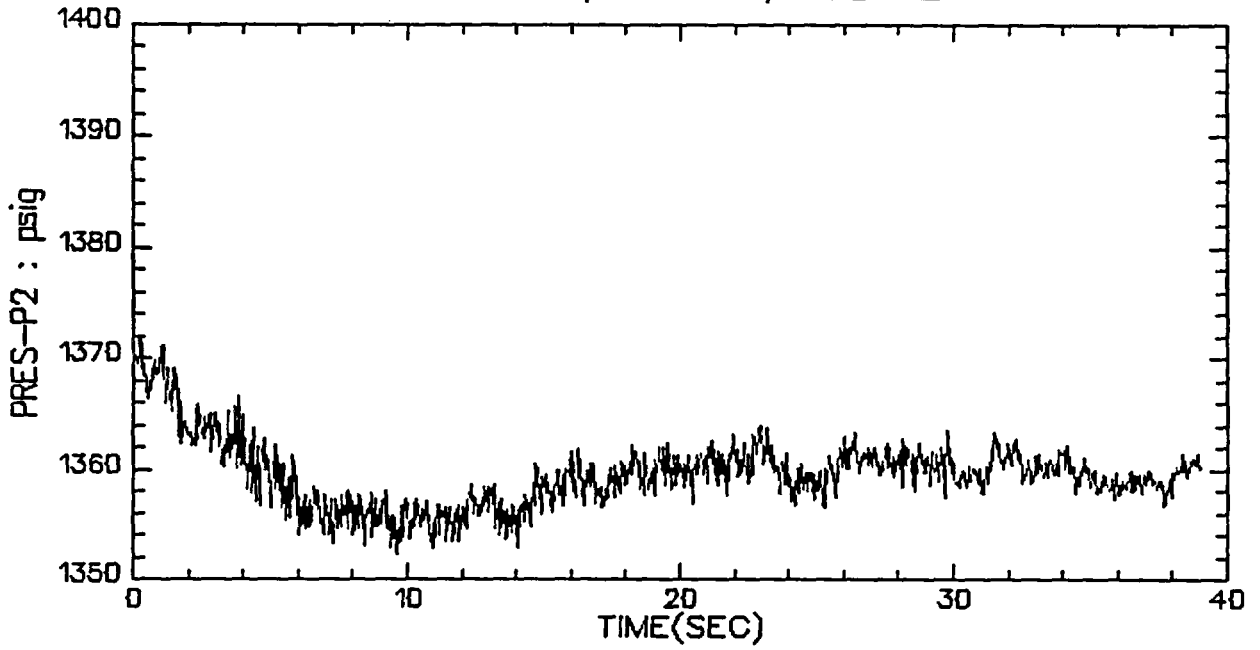

VALVE A, TEST 6, STEP 2

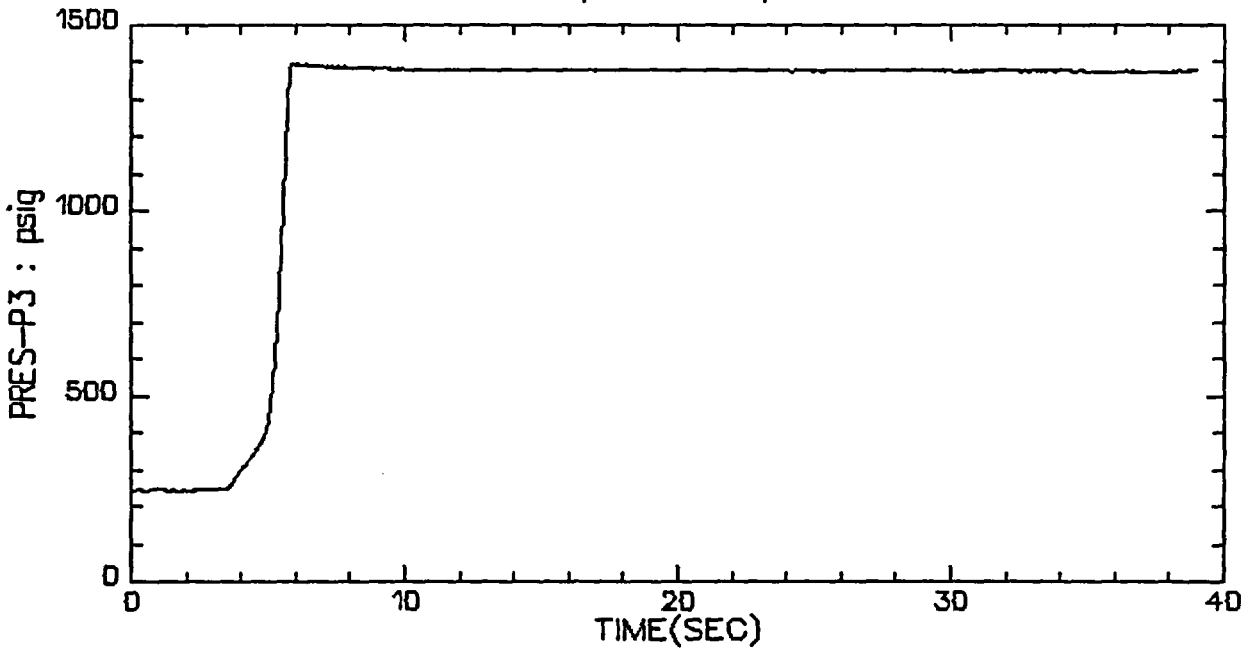

VALVE A, TEST 6, STEP 2

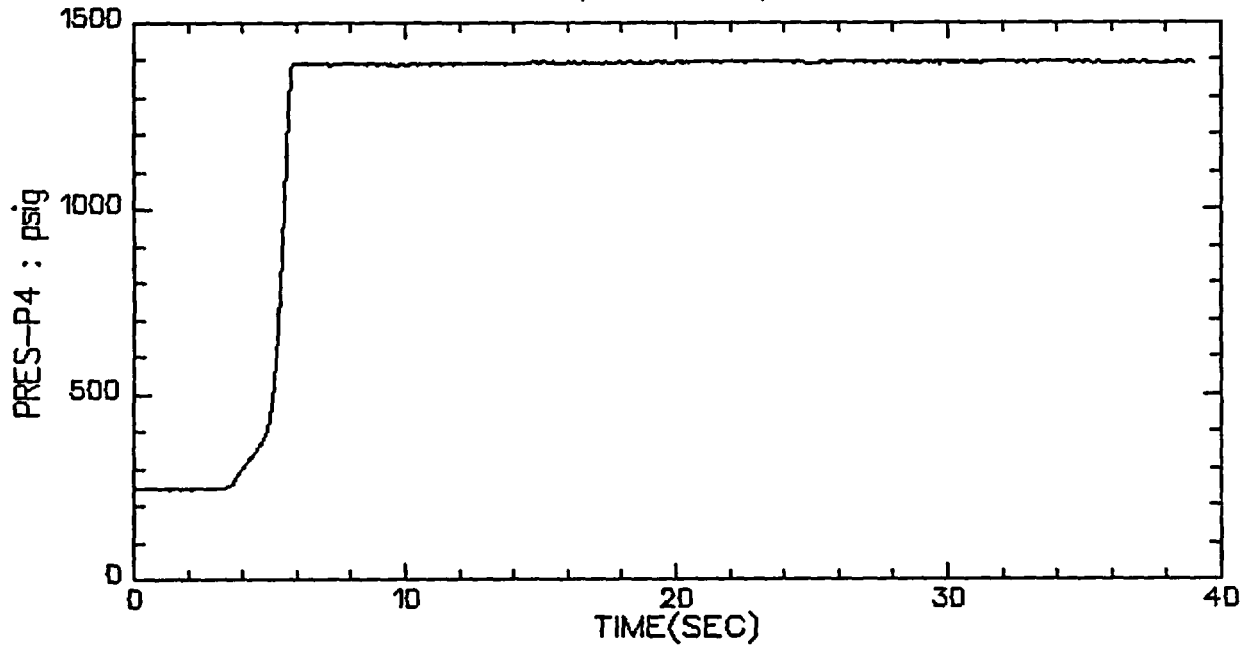

VALVE A, TEST 6, STEP 2

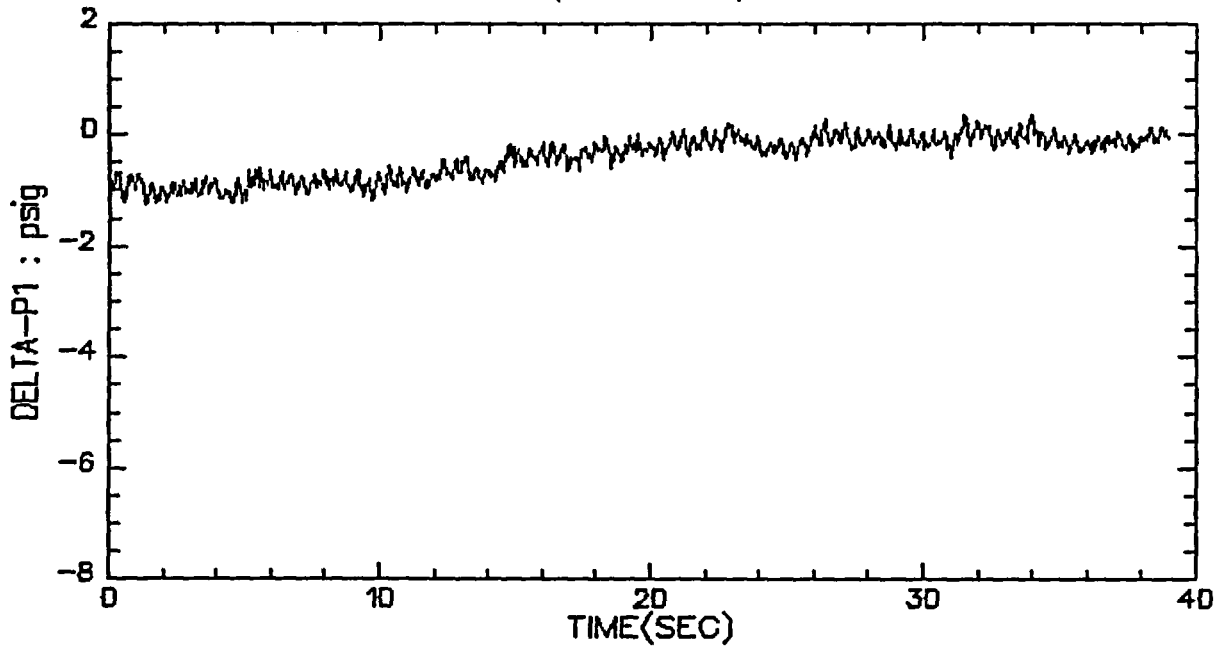

VALVE A, TEST 6, STEP 2

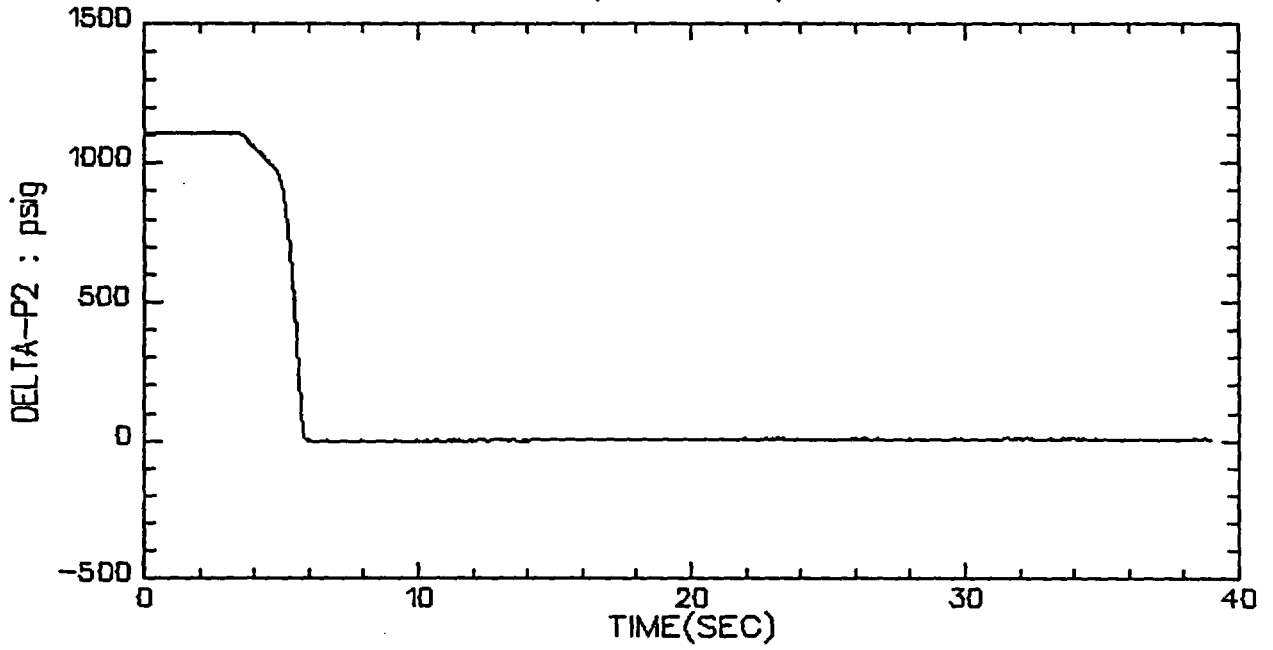

VALVE A, TEST 6, STEP 2

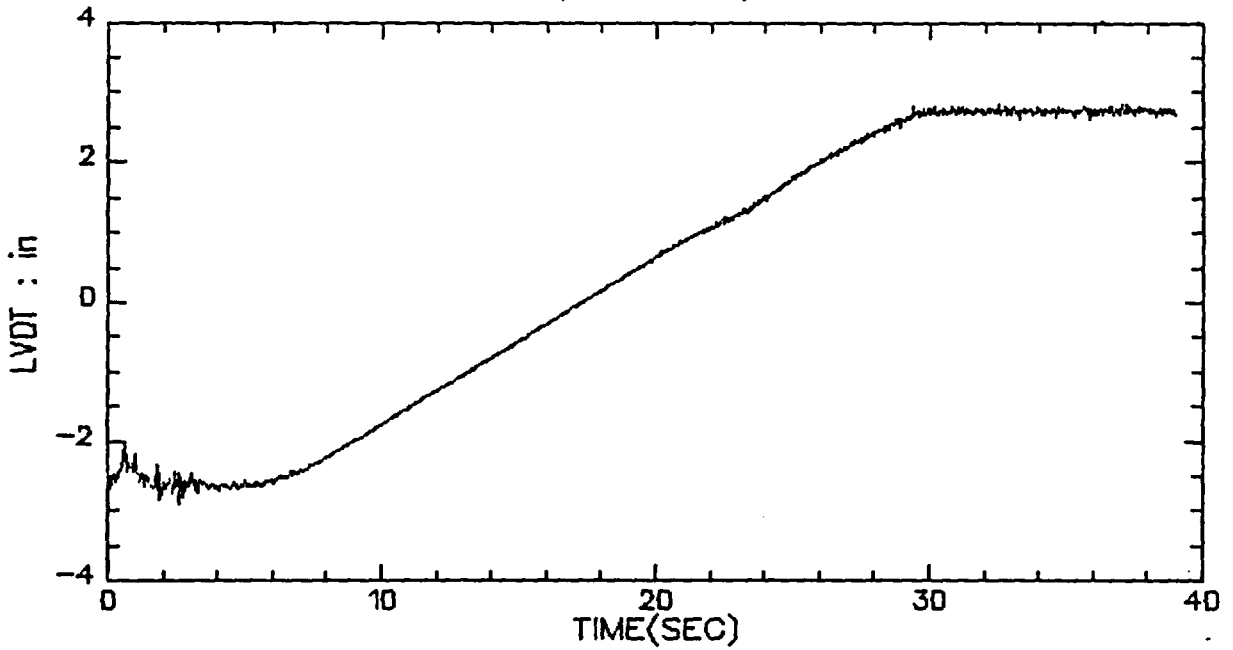

VALVE A, TEST 6, STEP 2

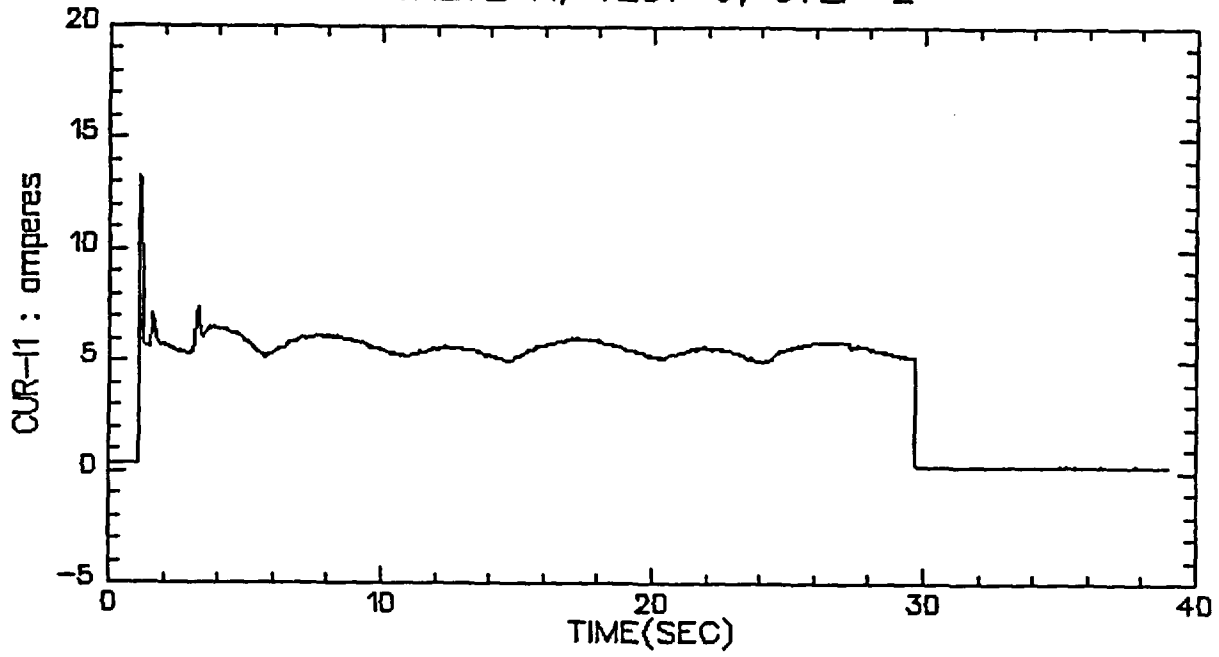

VALVE A, TEST 6, STEP 2

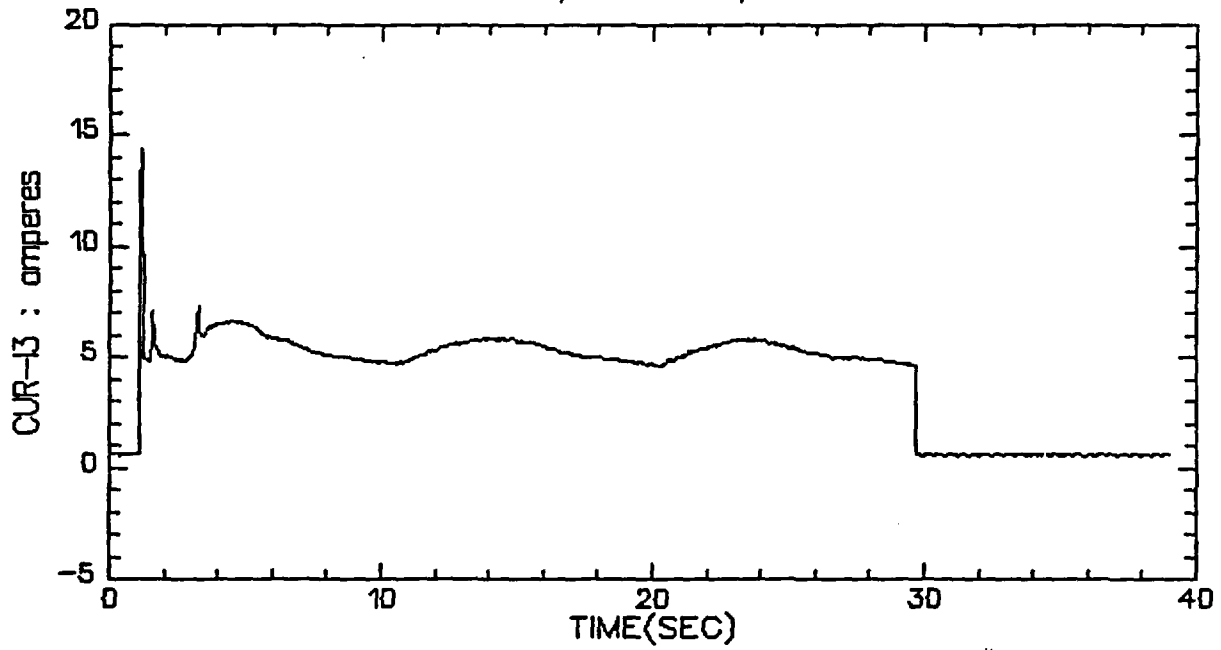

VALVE A, TEST 6, STEP 2

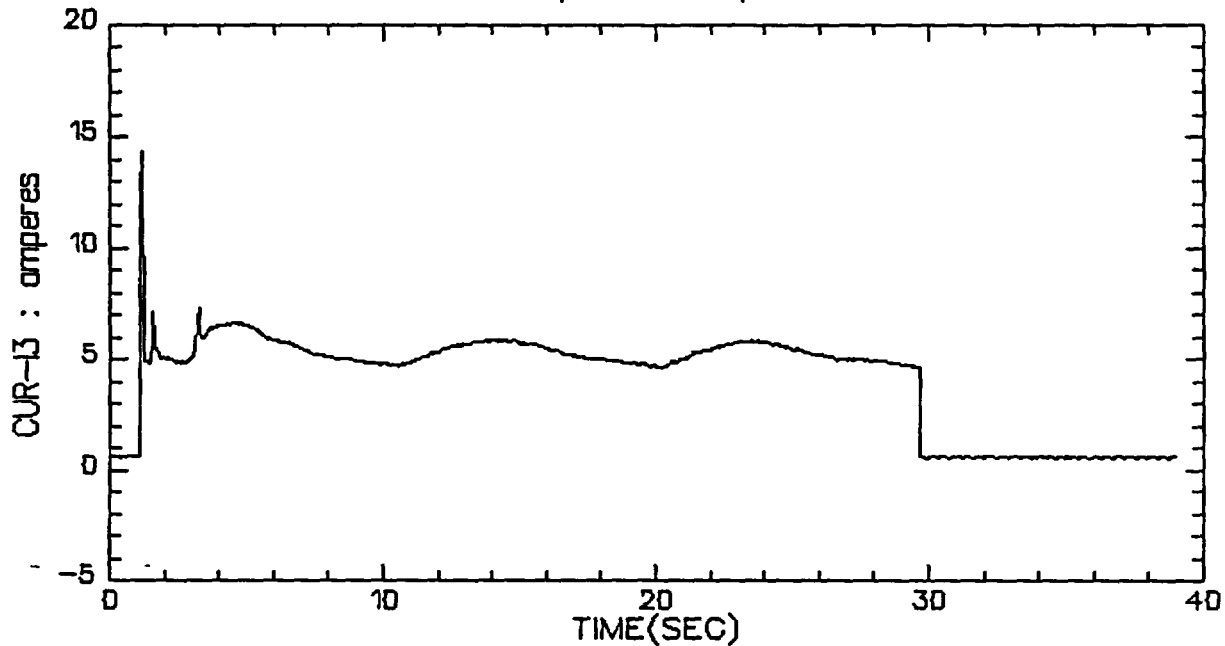

VALVE A, TEST 6, STEP 2

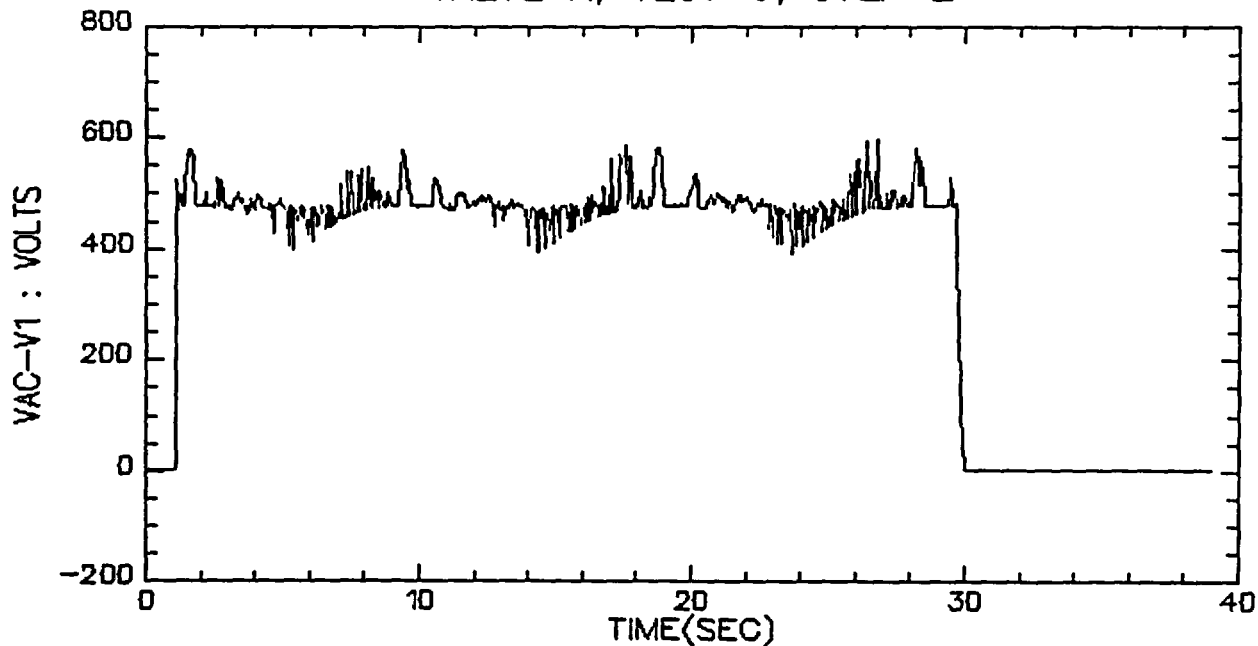

VALVE A, TEST 6, STEP 2

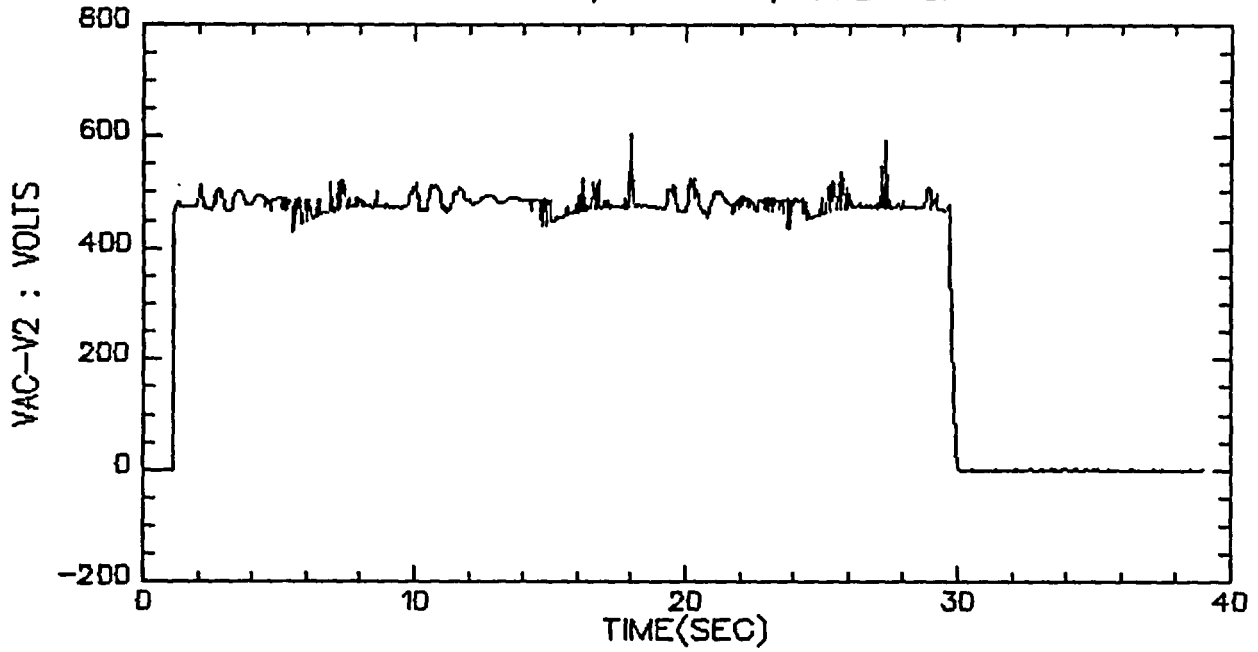

VALVE A, TEST 6, STEP 2

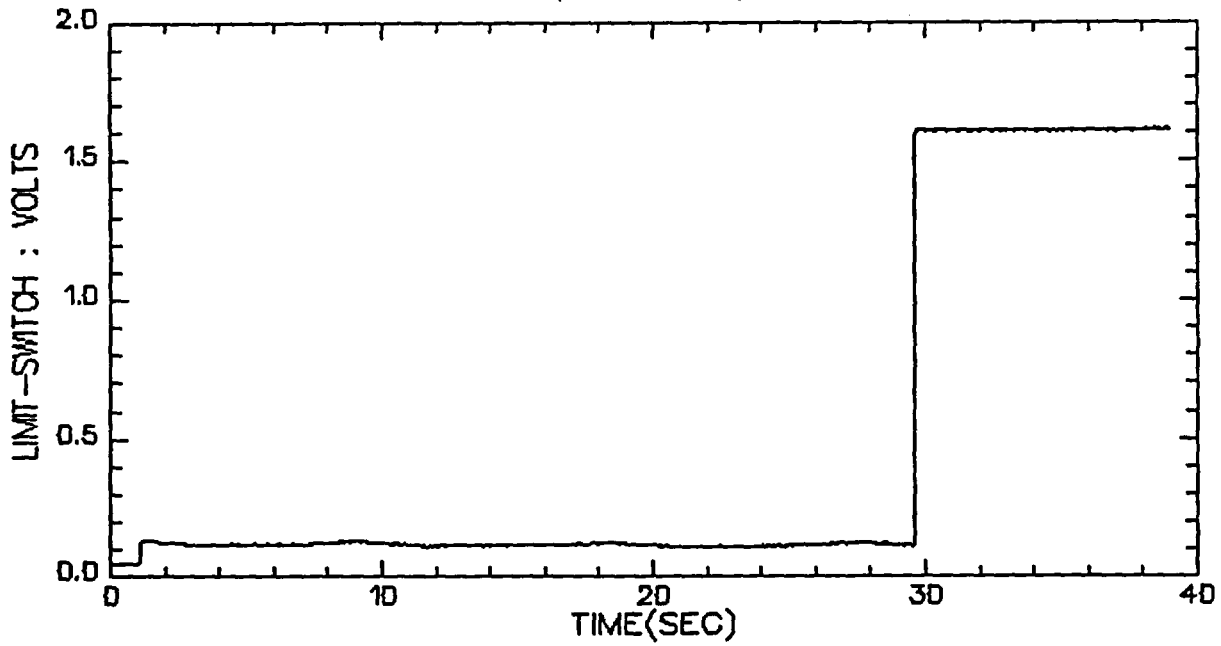

VALVE A, TEST 6, STEP 2

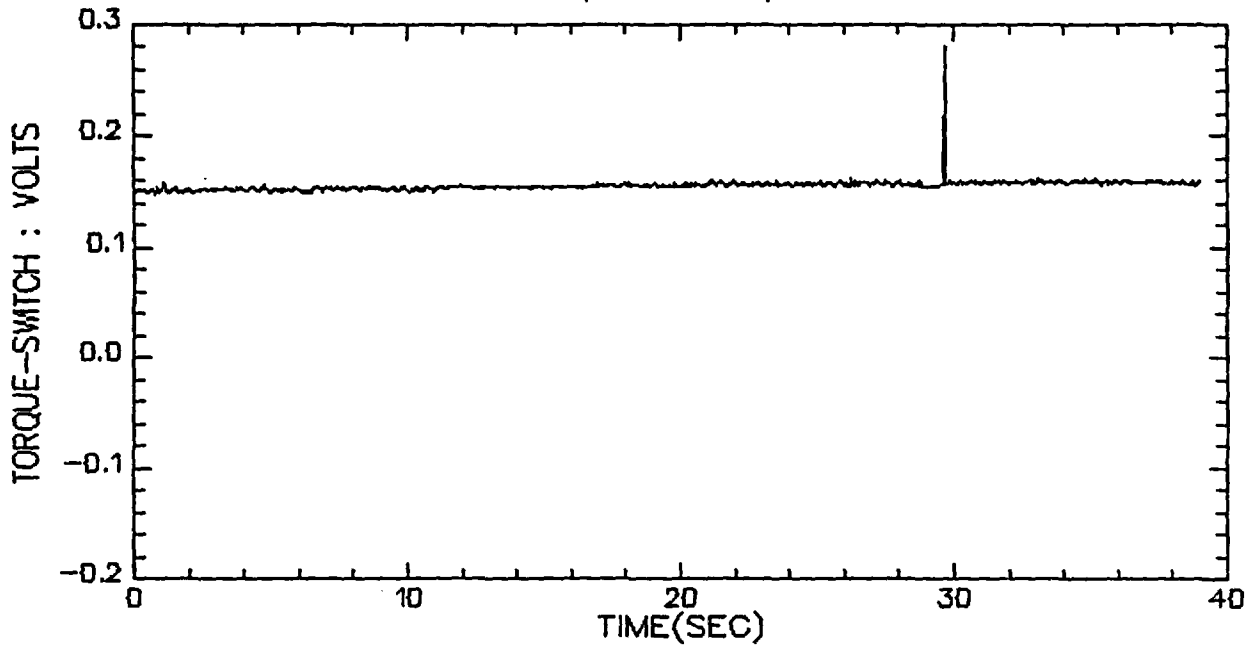

VALVE A, TEST 6, STEP 2

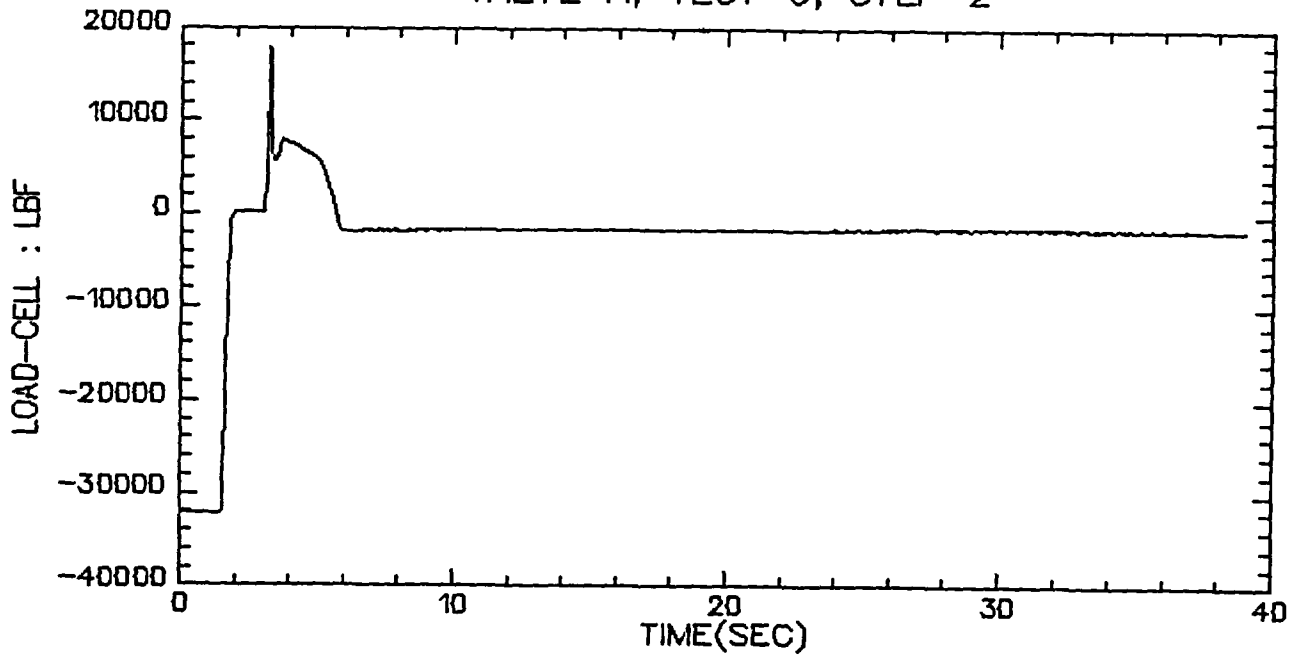

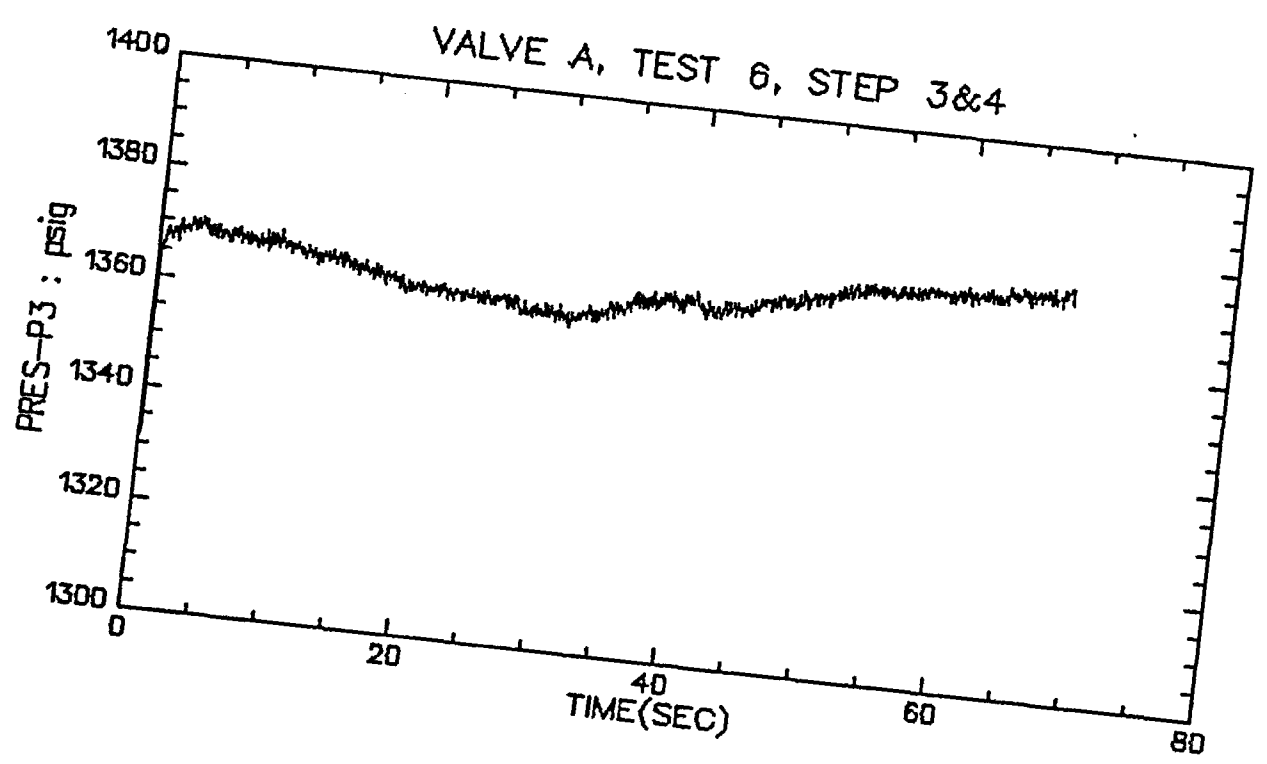
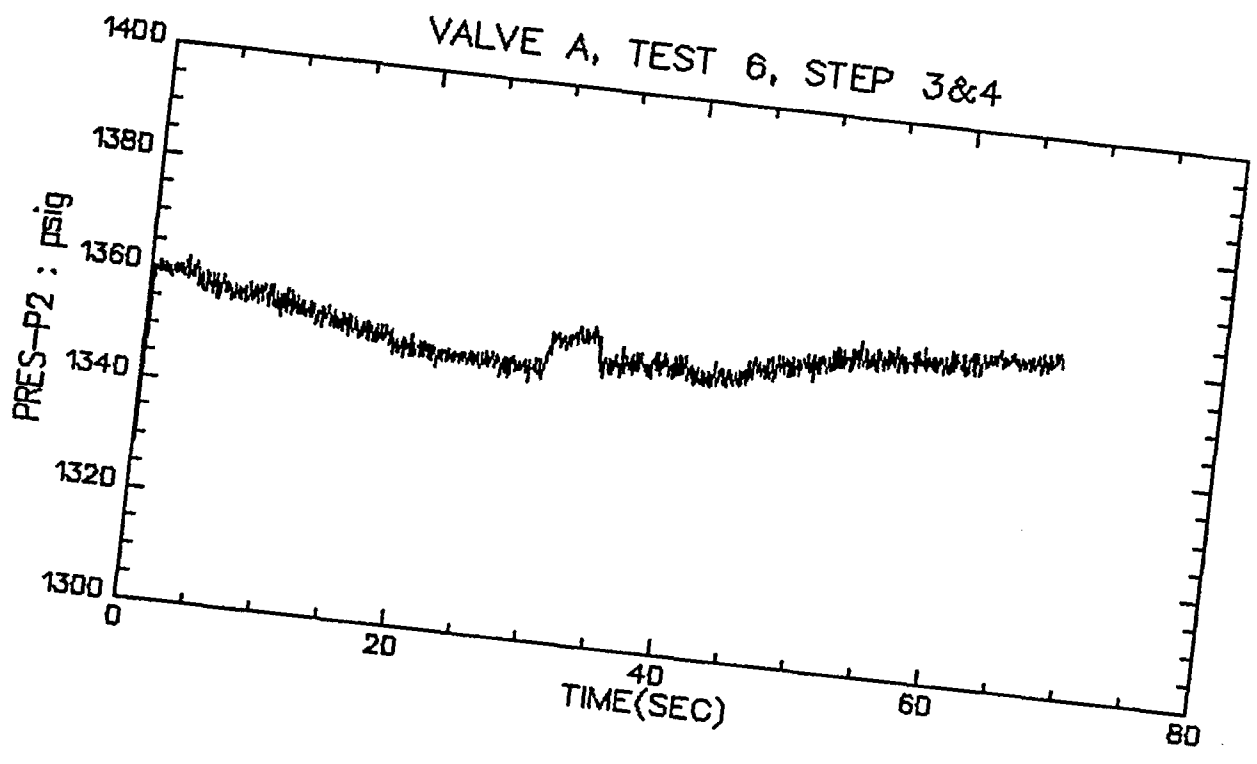

VALVE A, TEST 6, STEP 3&4

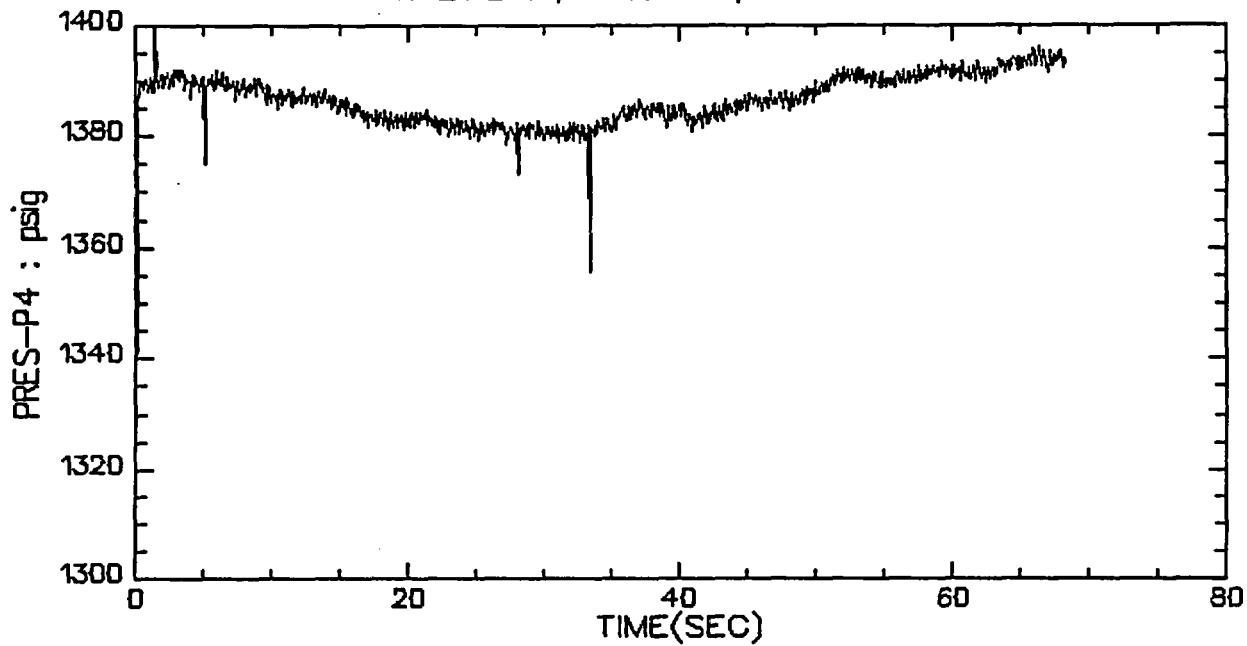

VALVE A, TEST 6, STEP 3&4

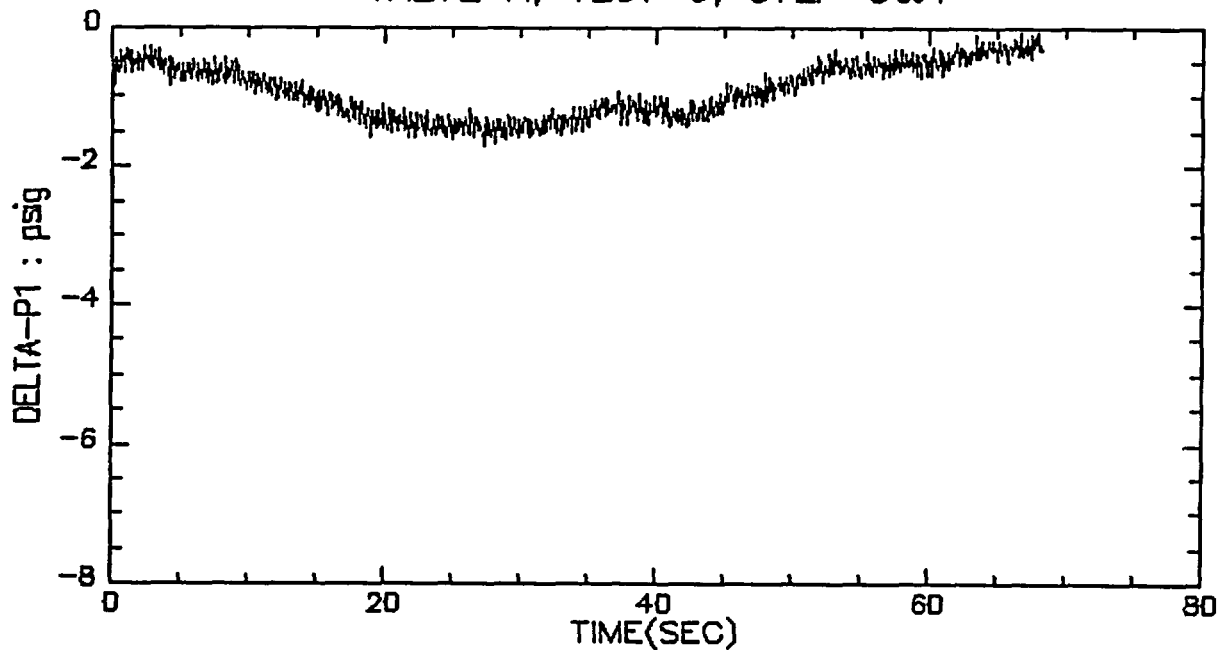

VALVE A, TEST 6, STEP 3&4

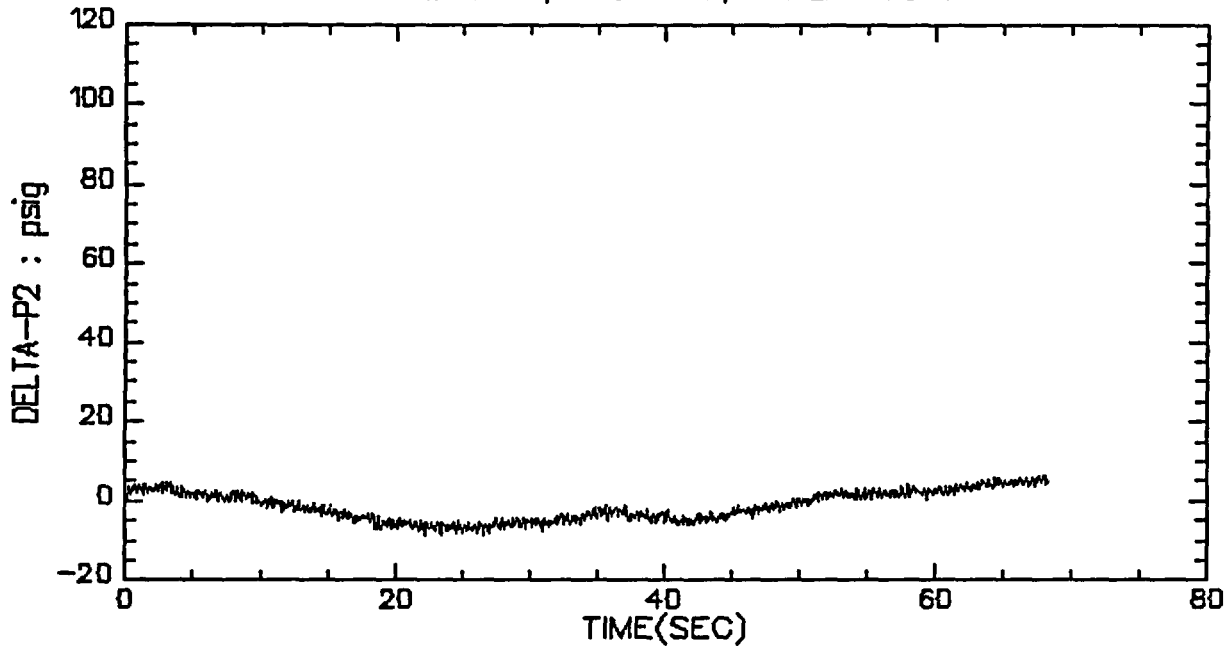

VALVE A, TEST 6, STEP 3&4

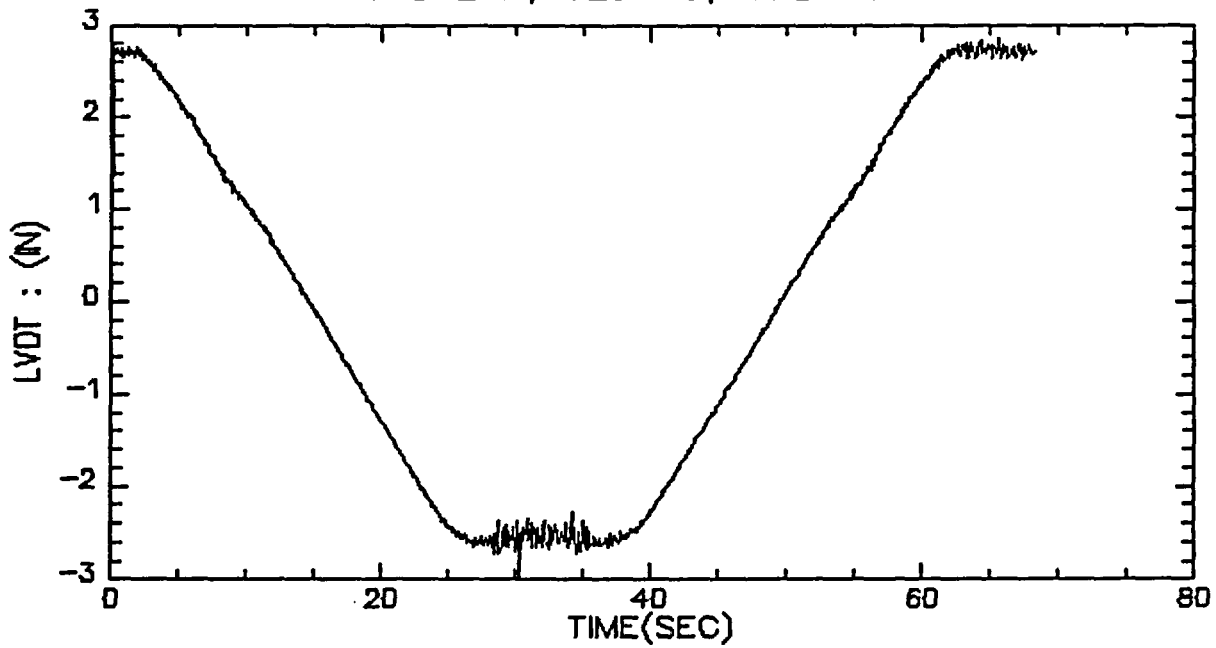

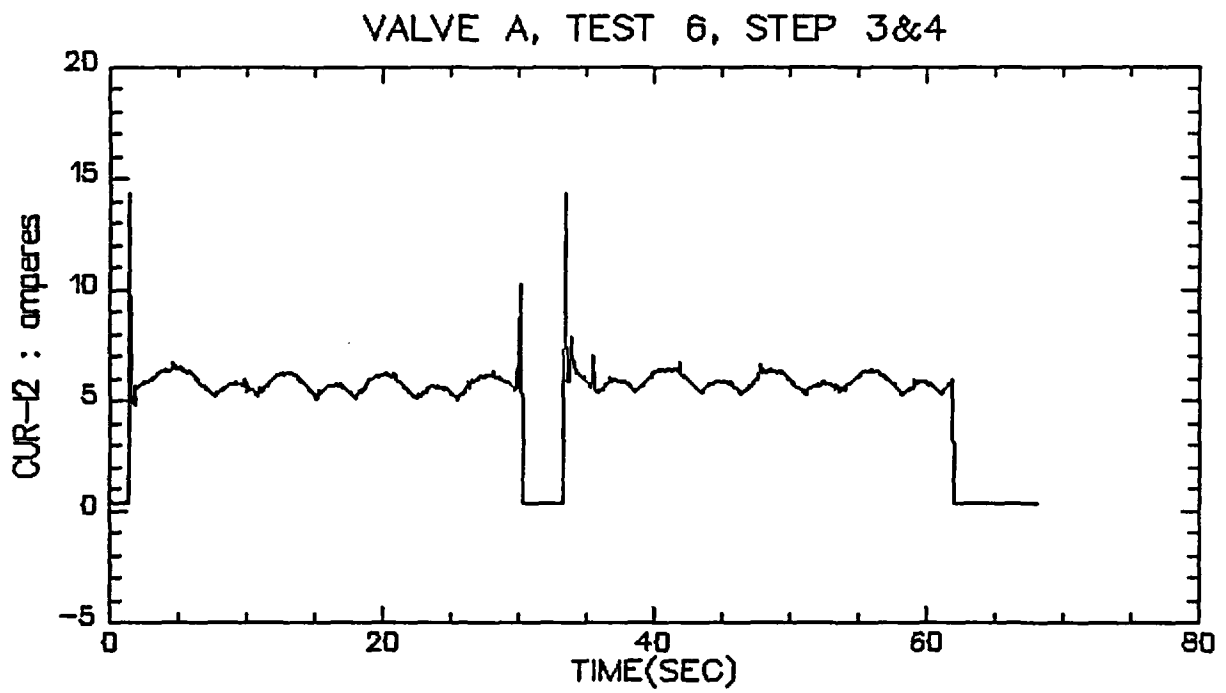
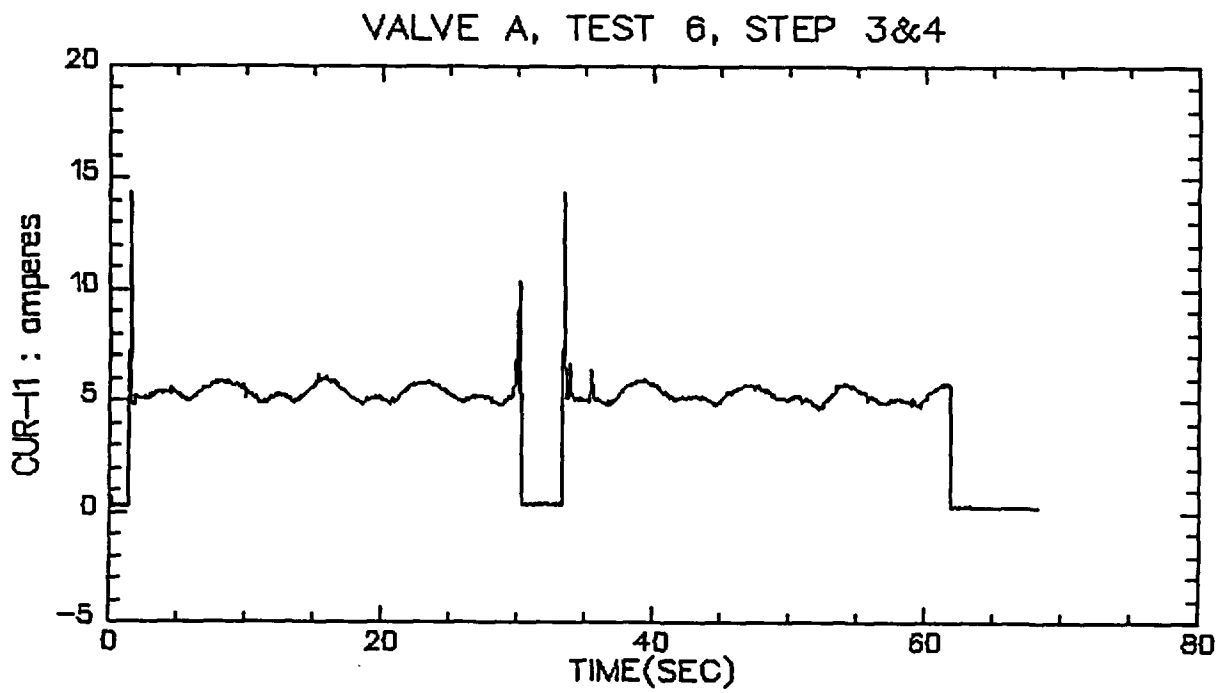

VALVE A, TEST 6, STEP 3&4

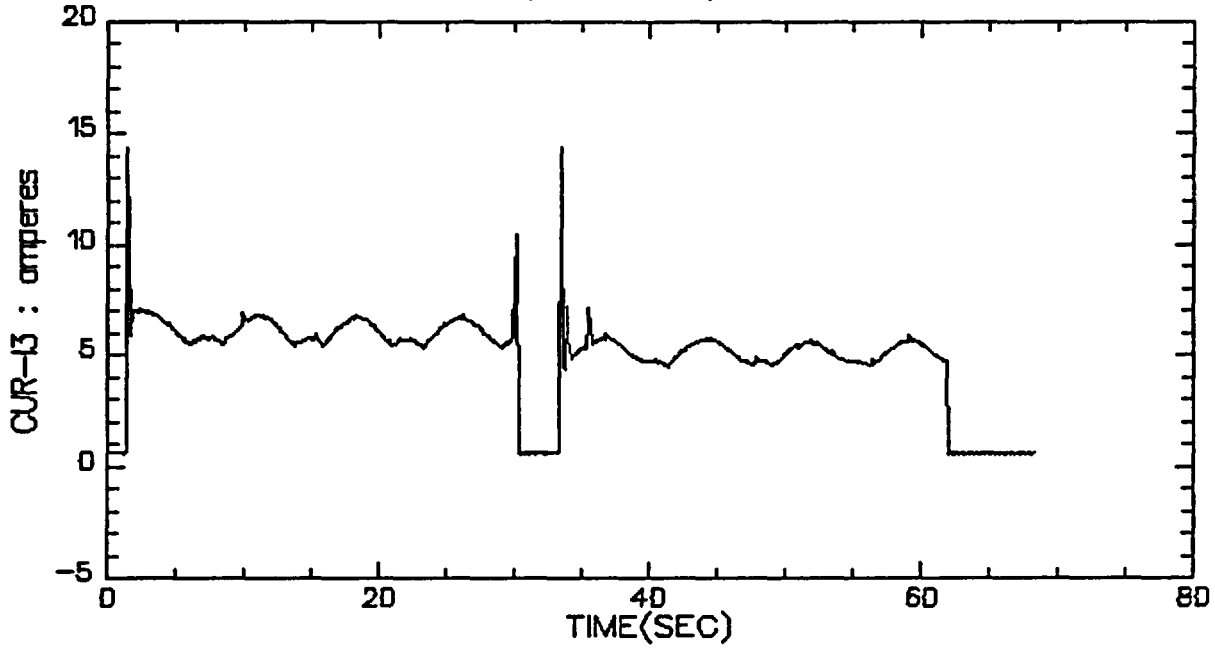

VALVE A, TEST 6, STEP 3&4

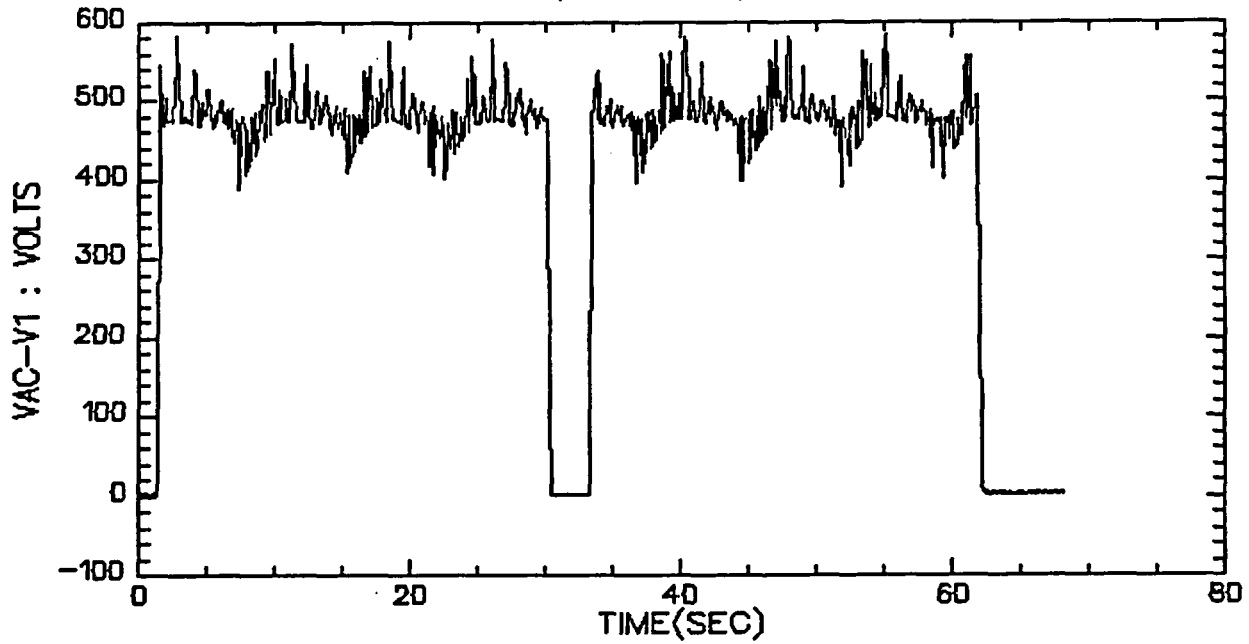

VALVE A, TEST 6, STEP 3&4

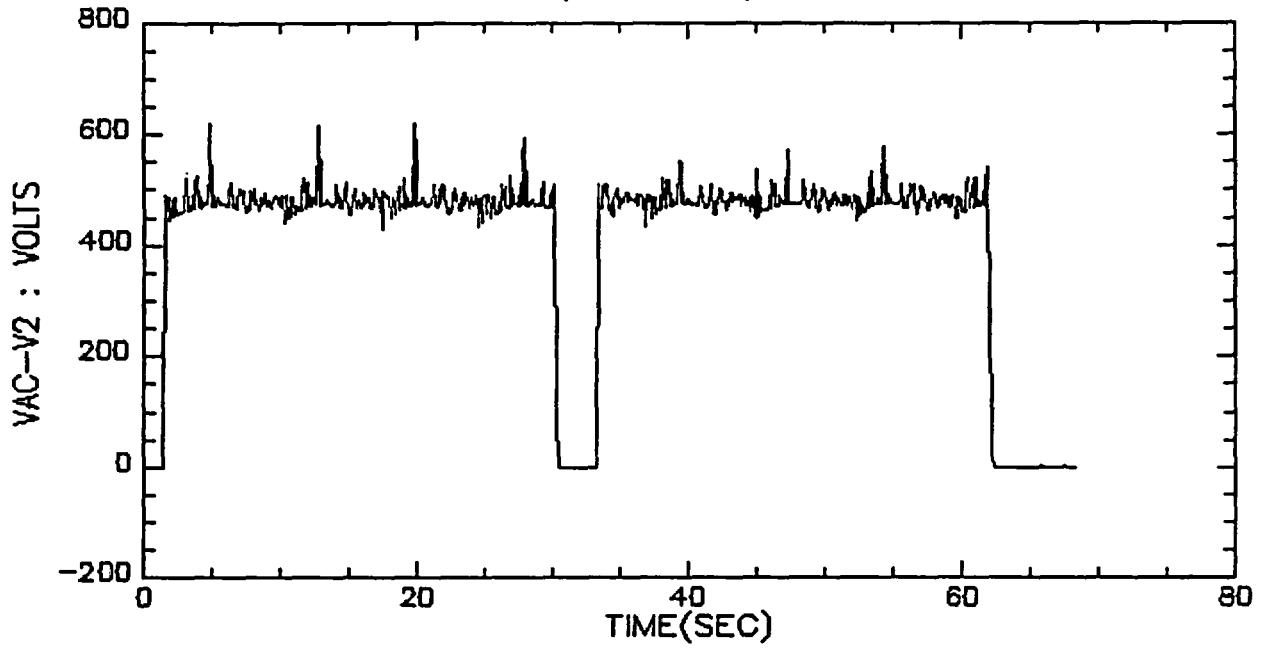

VALVE A, TEST 6, STEP 3&4

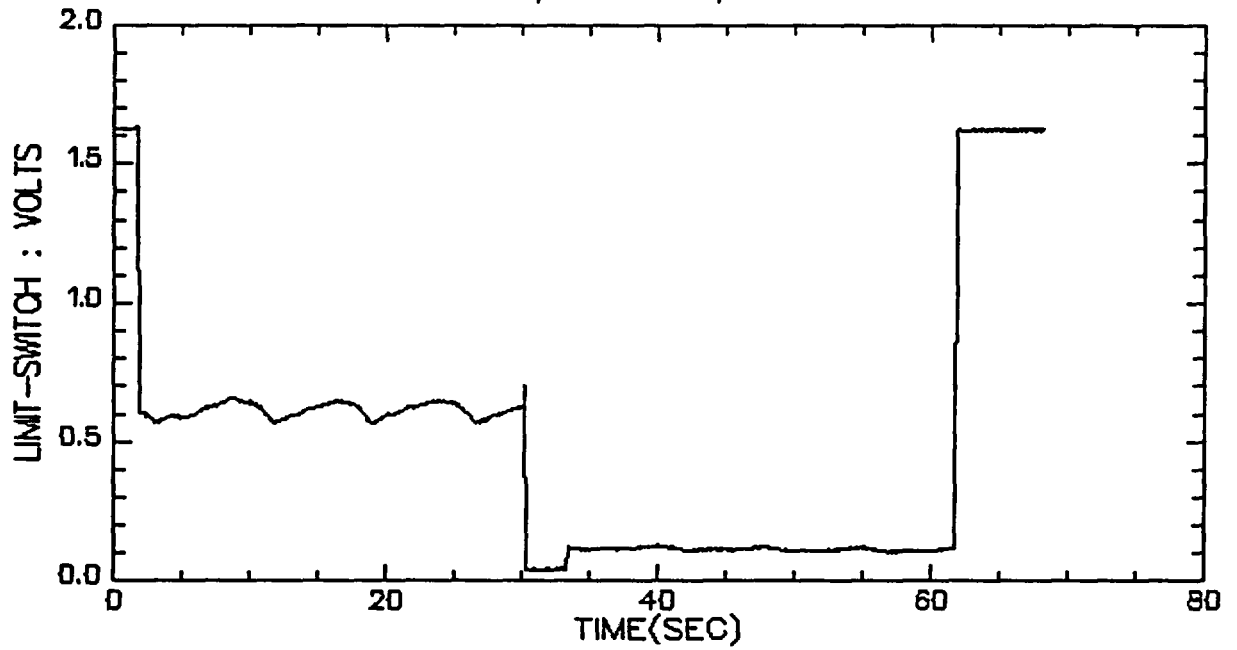

VALVE A, TEST 6, STEP 3&4

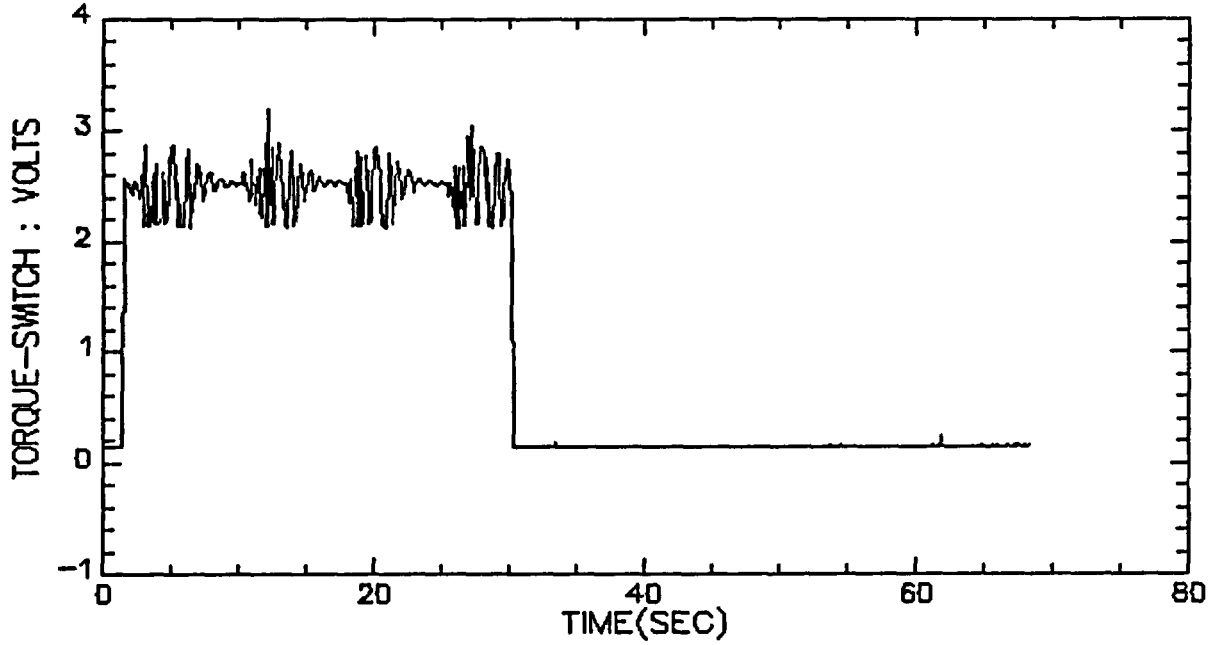

VALVE A, TEST 6, STEP 3&4

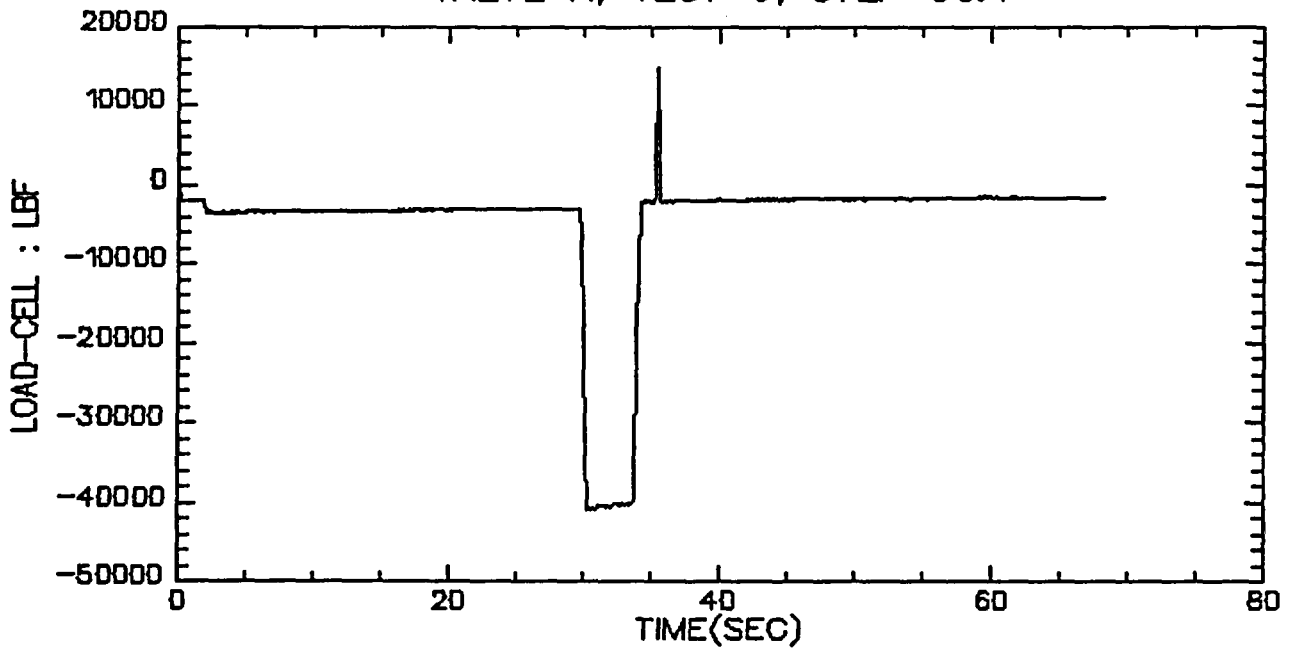

VALVE A, TEST 6, STEP 5

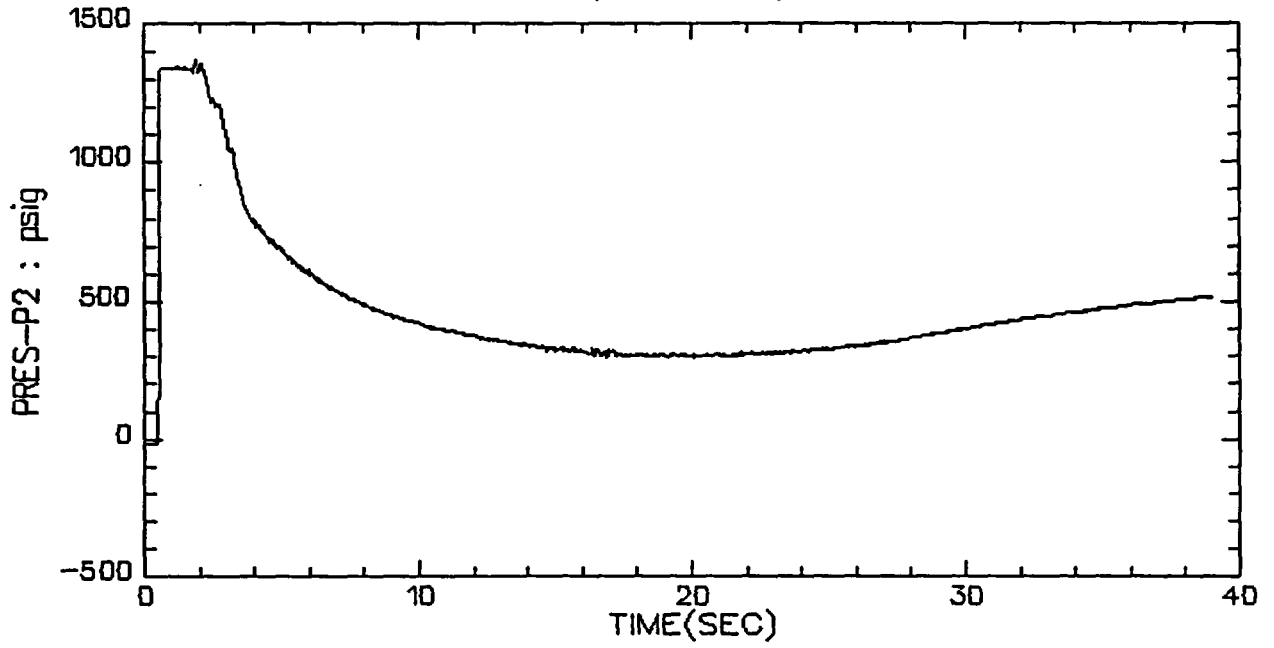

VALVE A, TEST 6, STEP 5

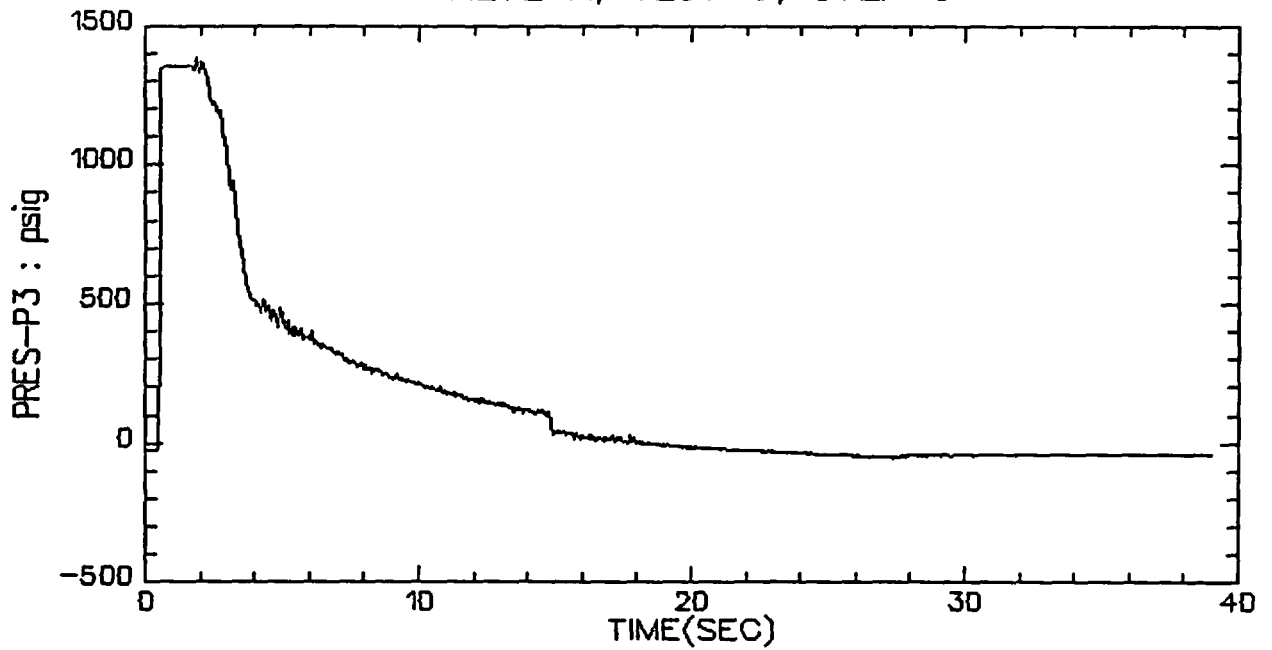

VALVE A, TEST 6, STEP 5

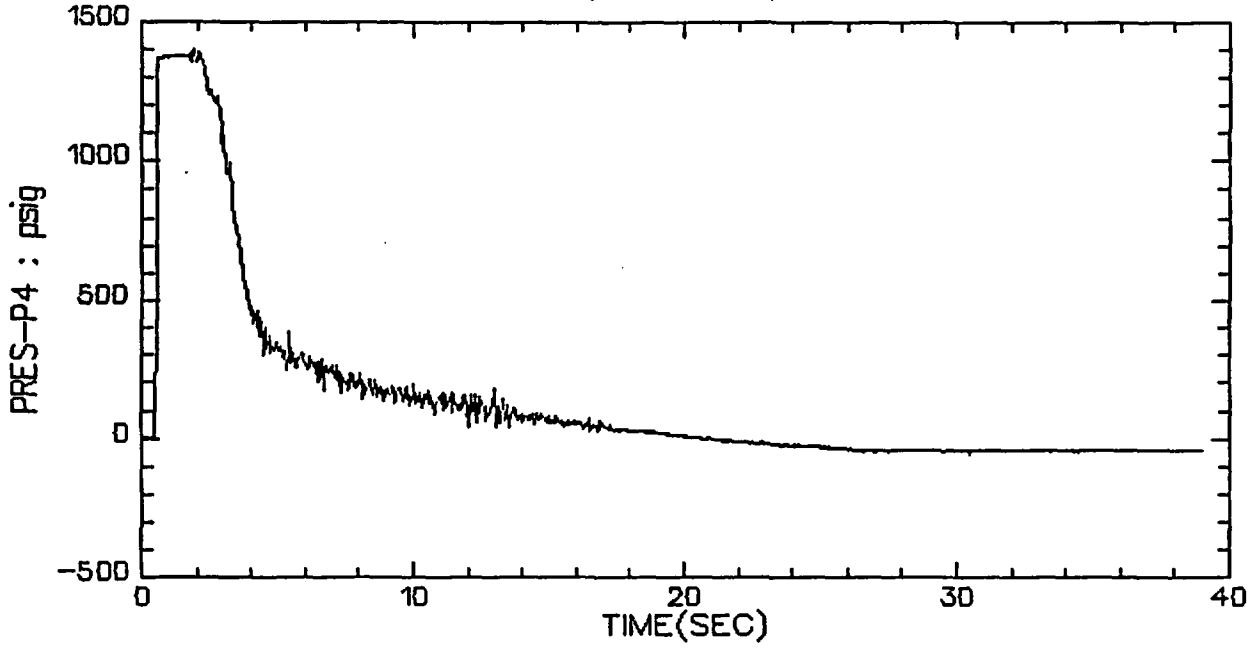

VALVE A, TEST 6, STEP 5

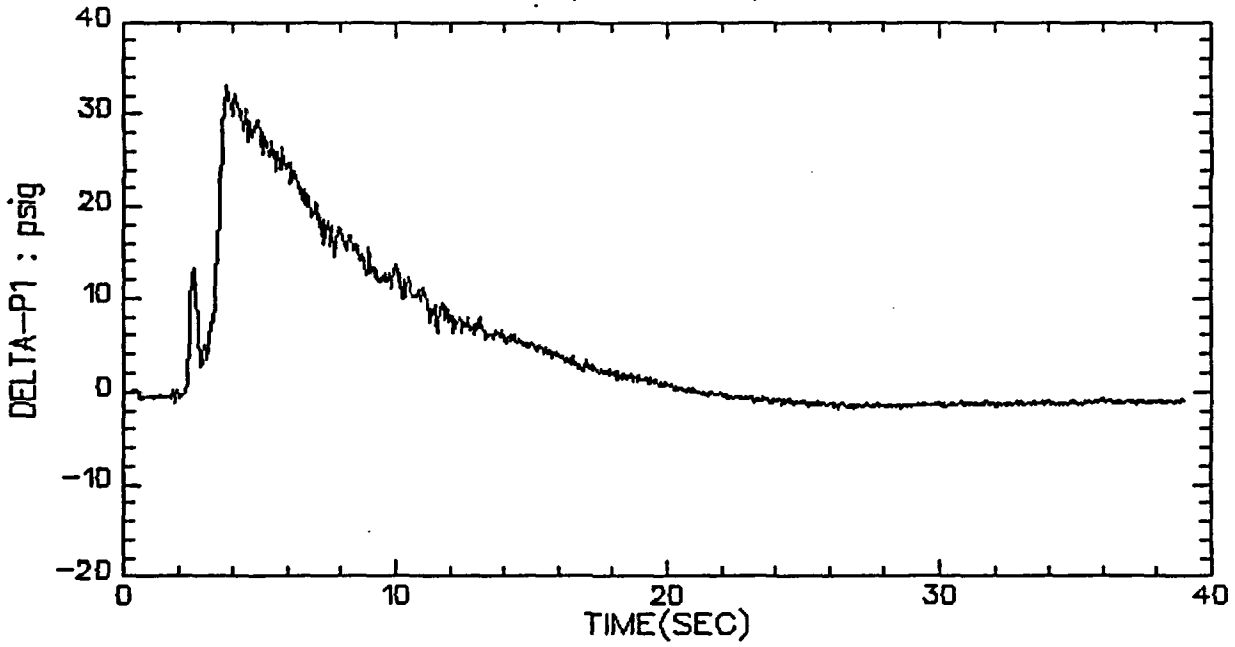

VALVE A, TEST 6, STEP 5

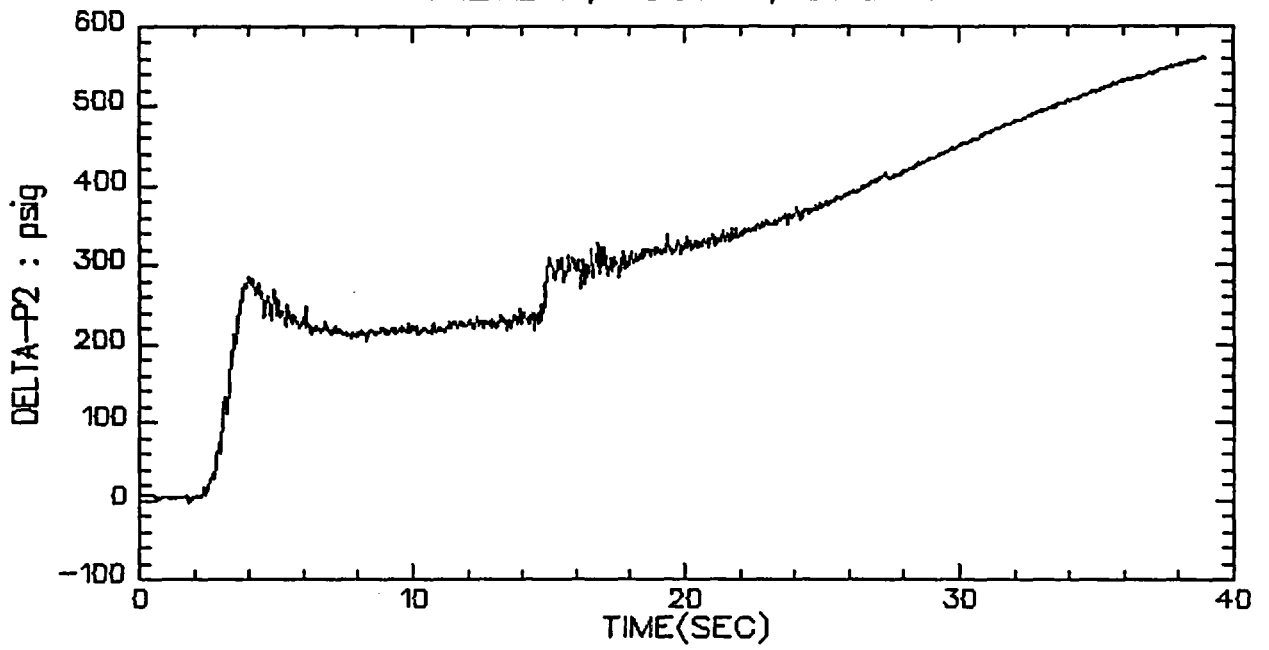

VALVE A, TEST 6, STEP 5

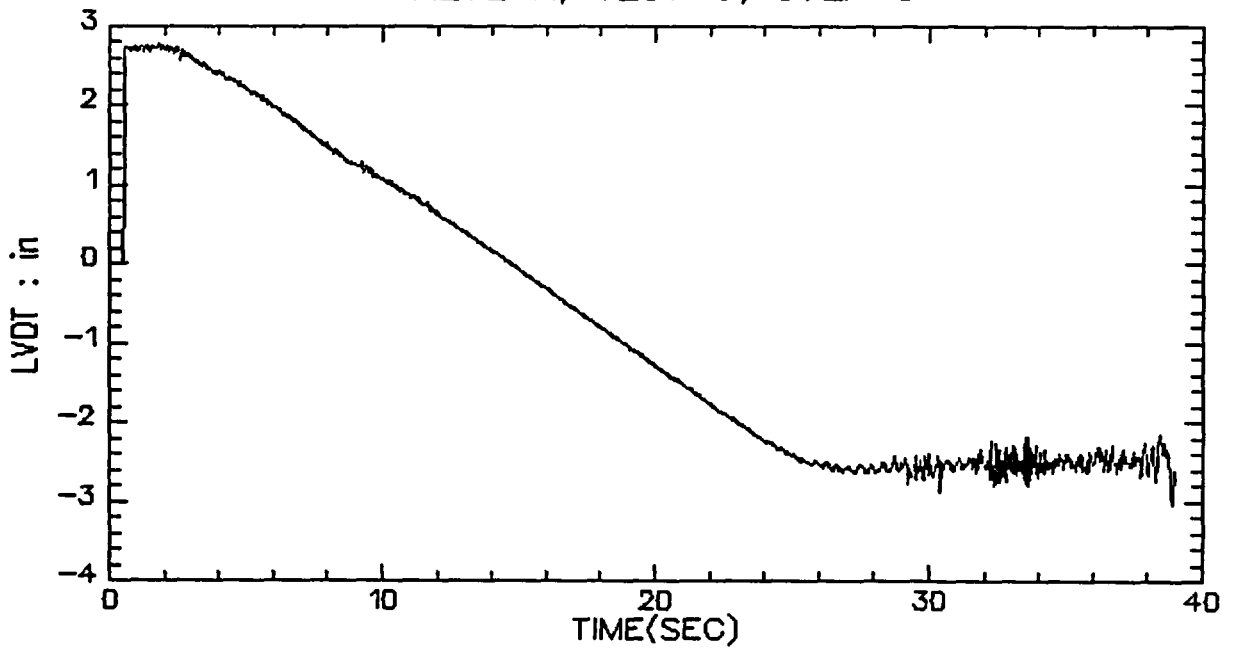

VALVE A, TEST 6, STEP 5

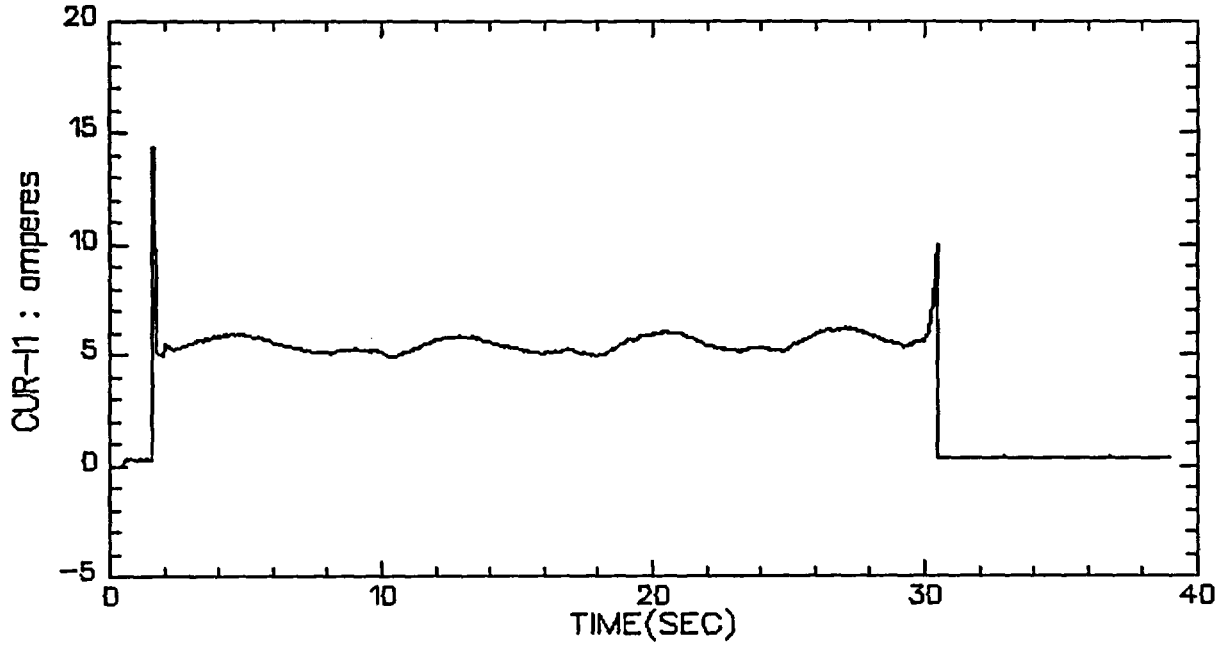

VALVE A, TEST 6, STEP 5

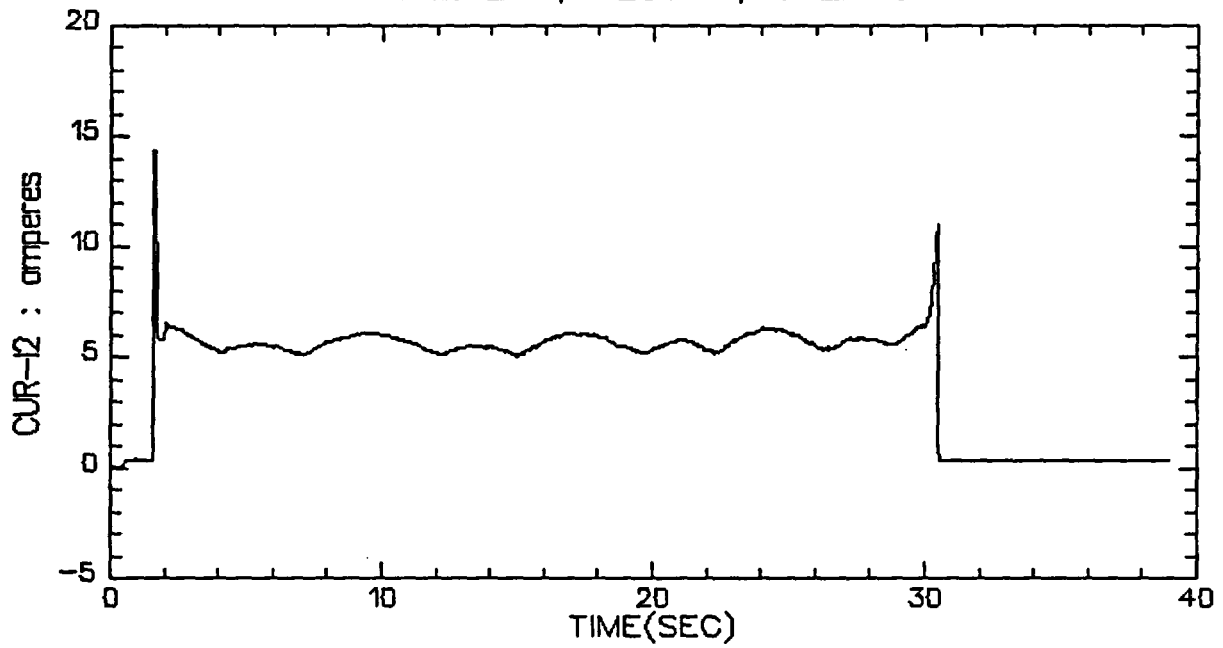

VALVE A, TEST 6, STEP 5

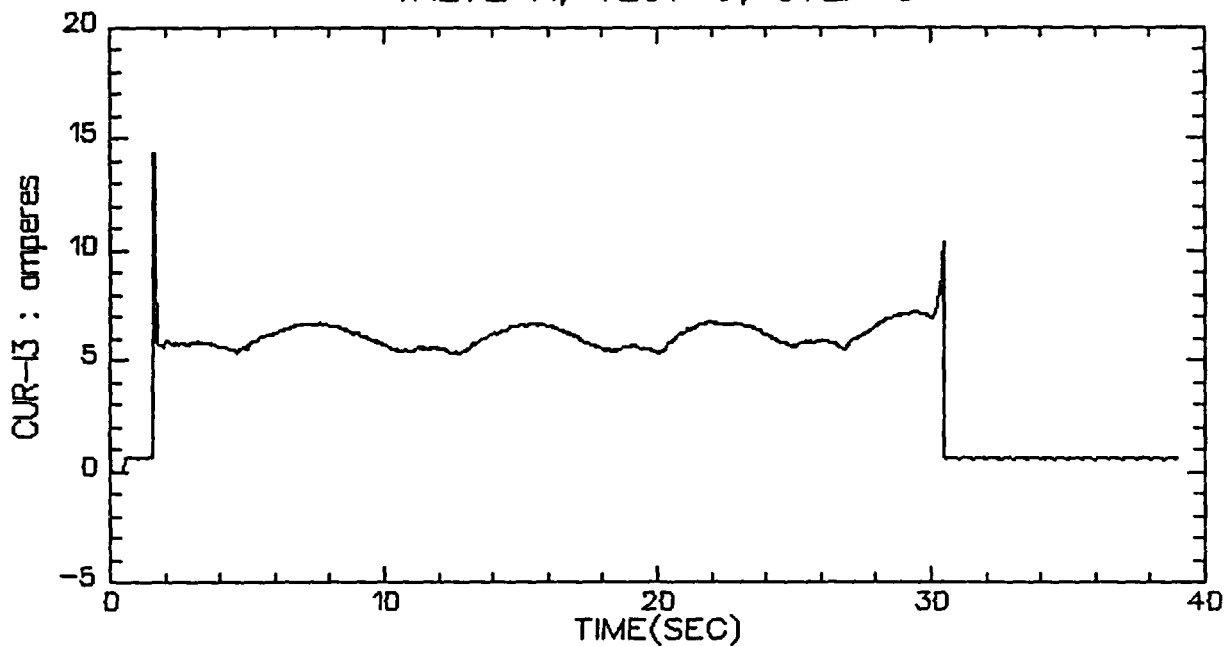

VALVE A, TEST 6, STEP 5

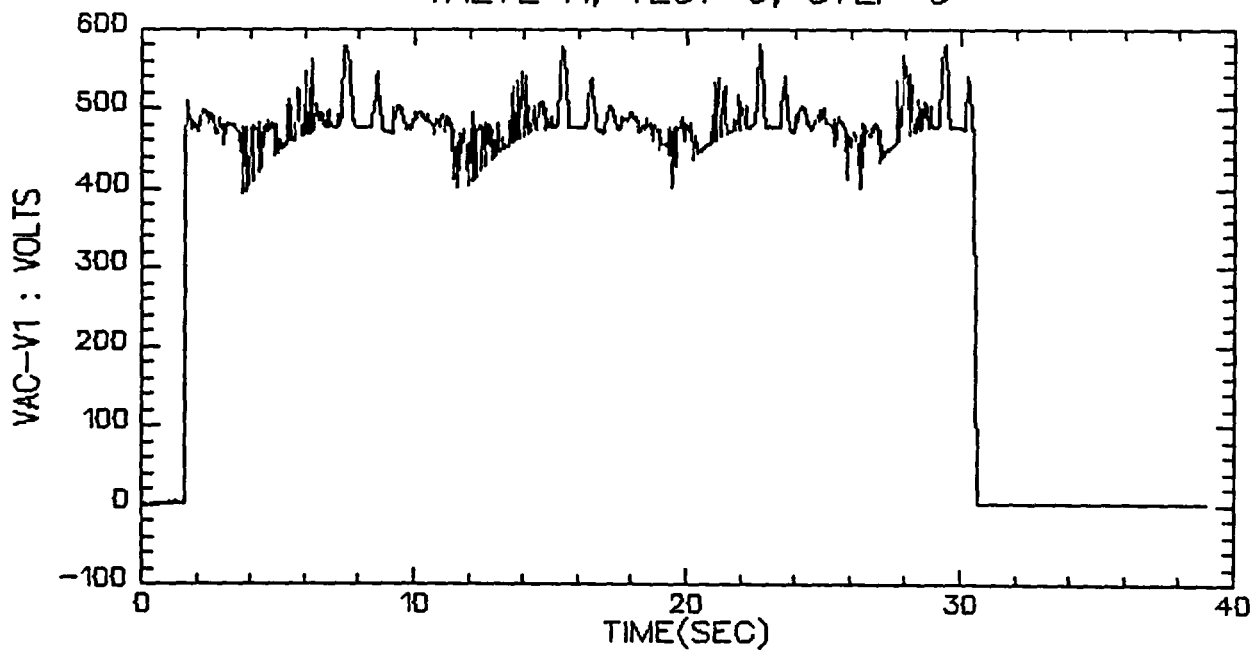

VALVE A, TEST 6, STEP 5

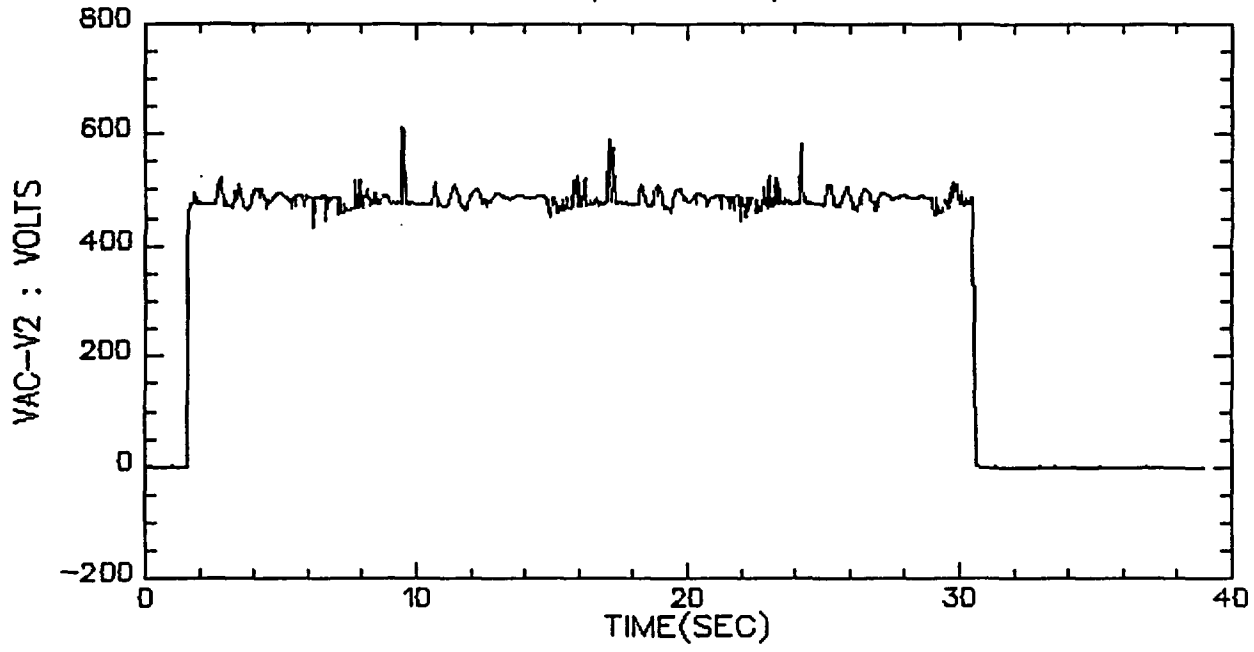

VALVE A, TEST 6, STEP 5

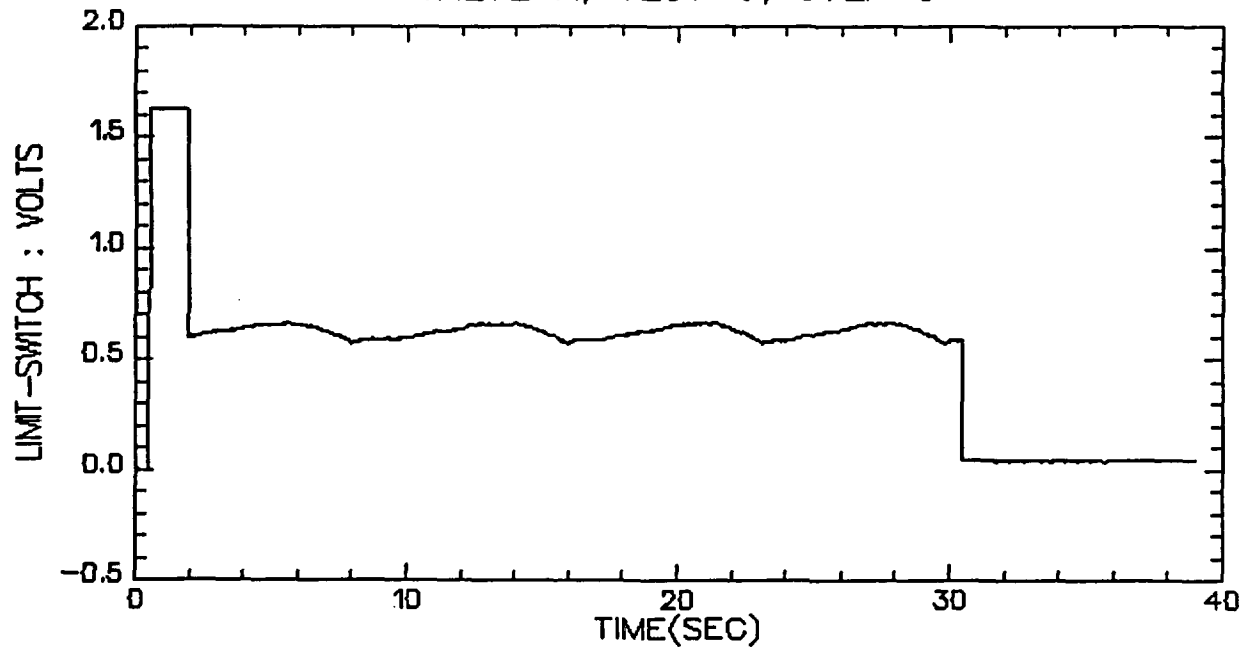

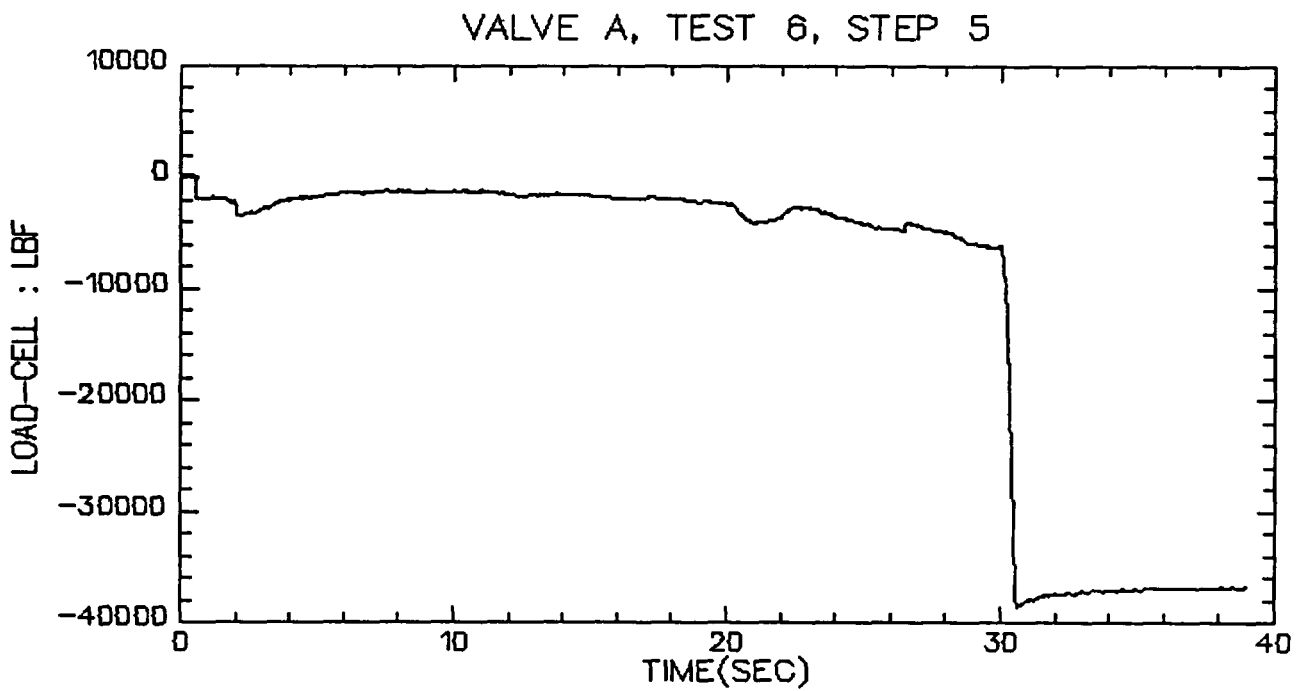
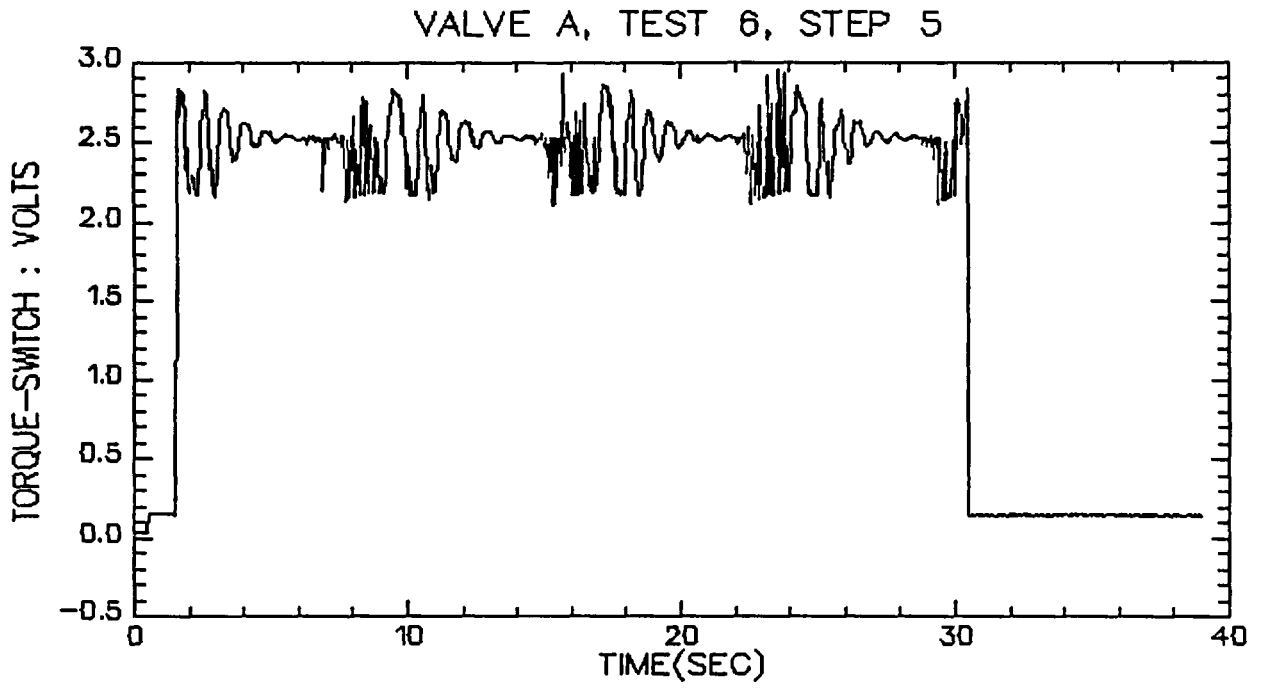

VALVE A, TEST 6, STEP 8&9

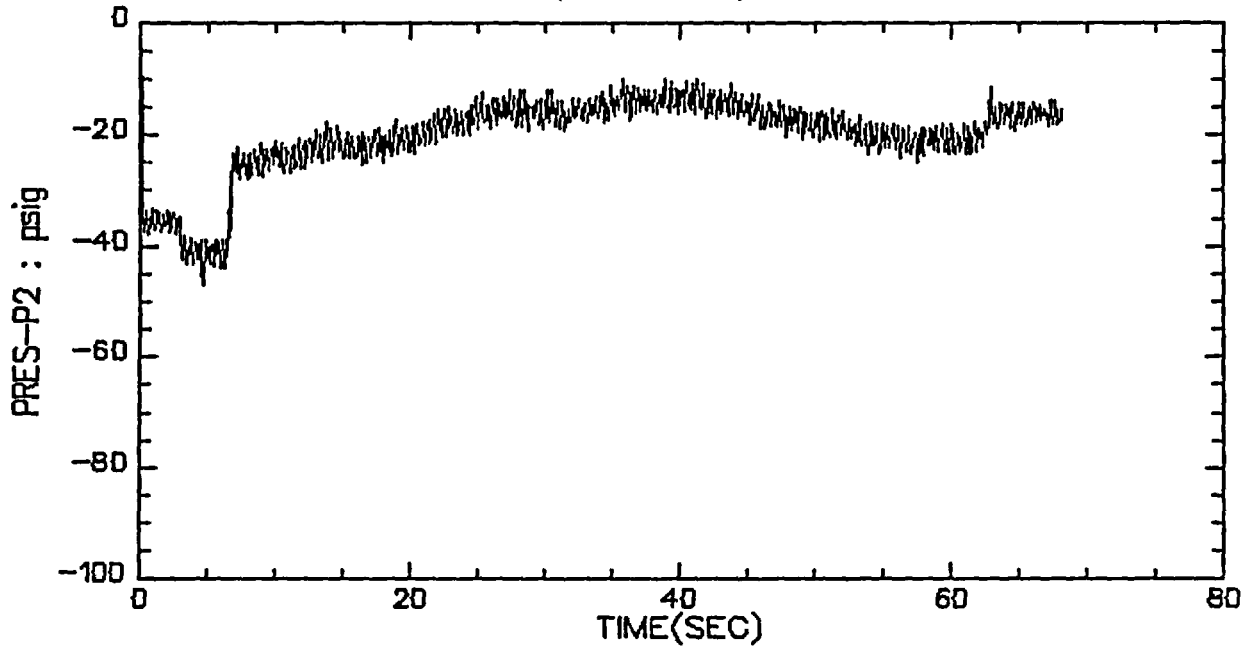

VALVE A, TEST 6, STEP 8&9

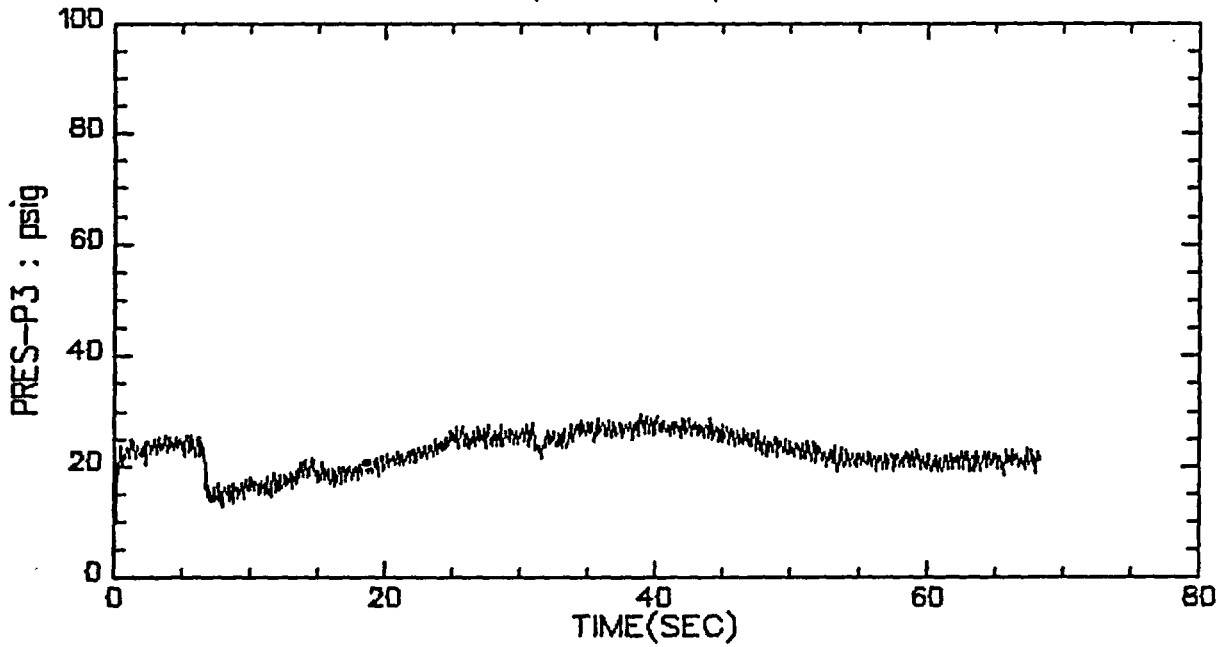

VALVE A, TEST 6, STEP 8&9

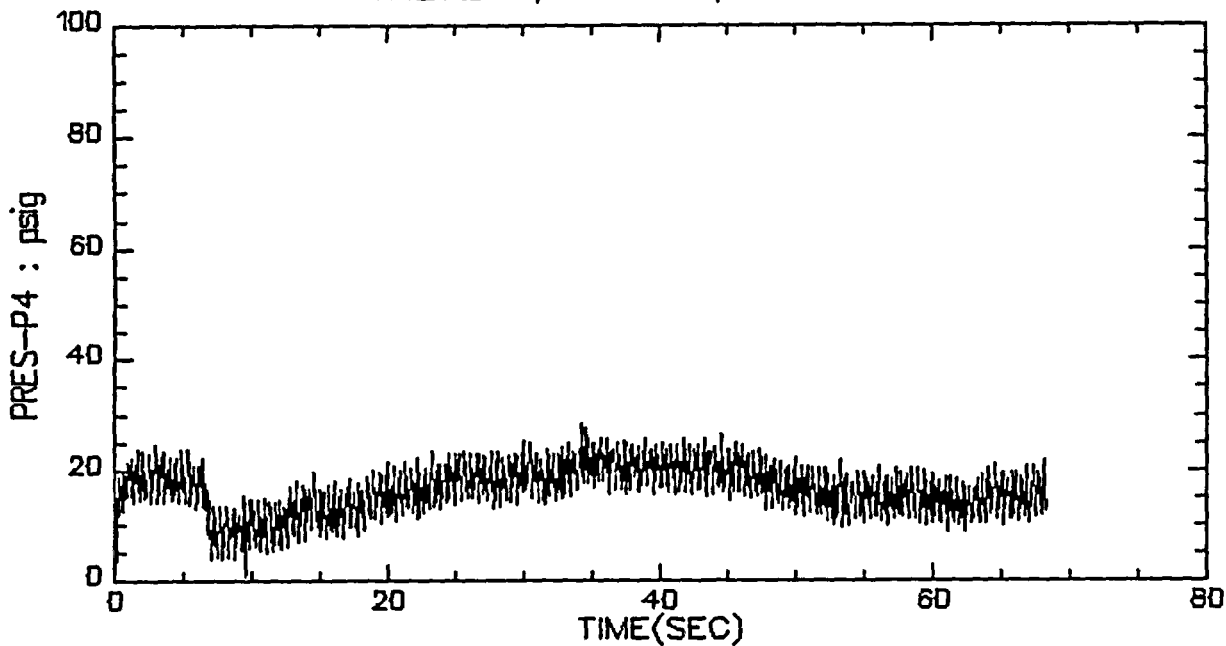

VALVE A, TEST 6, STEP 8&9

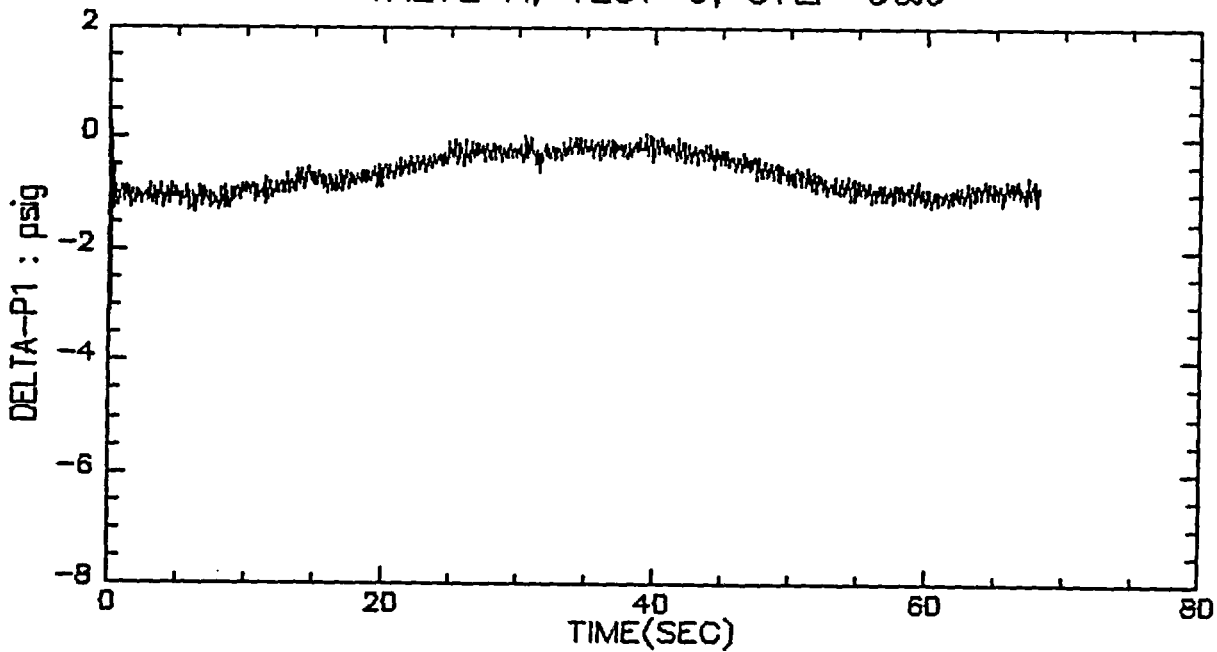

VALVE A, TEST 6, STEP 8&9

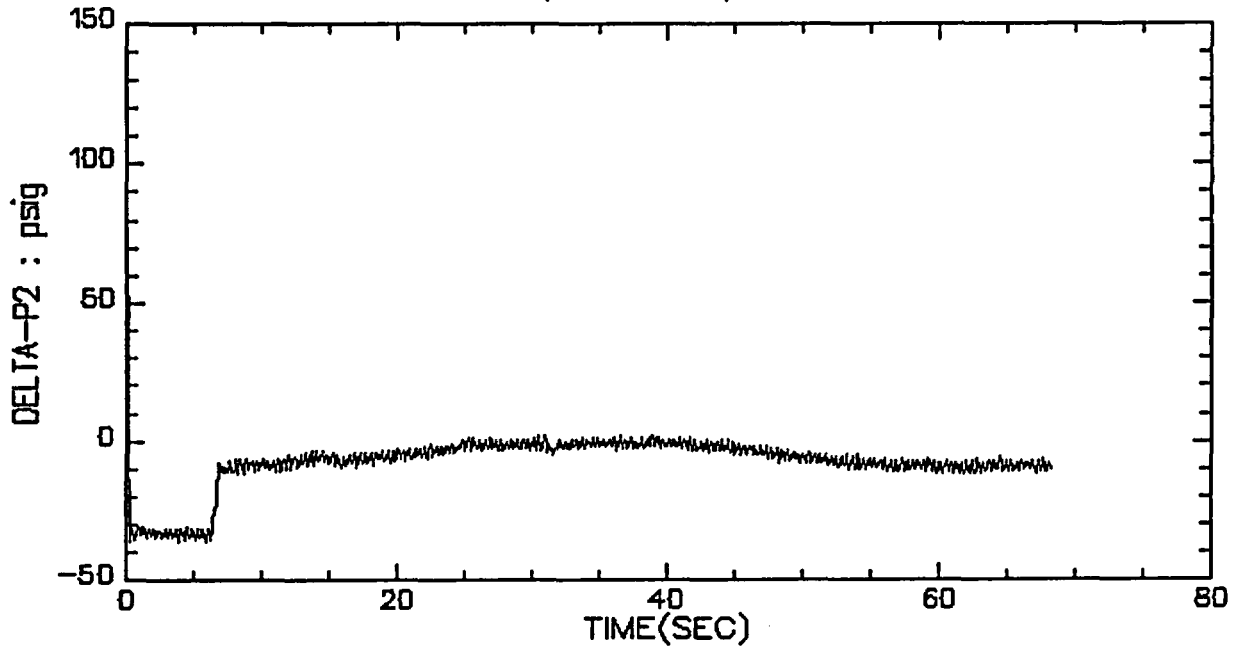

VALVE A, TEST 6, STEP 8&9

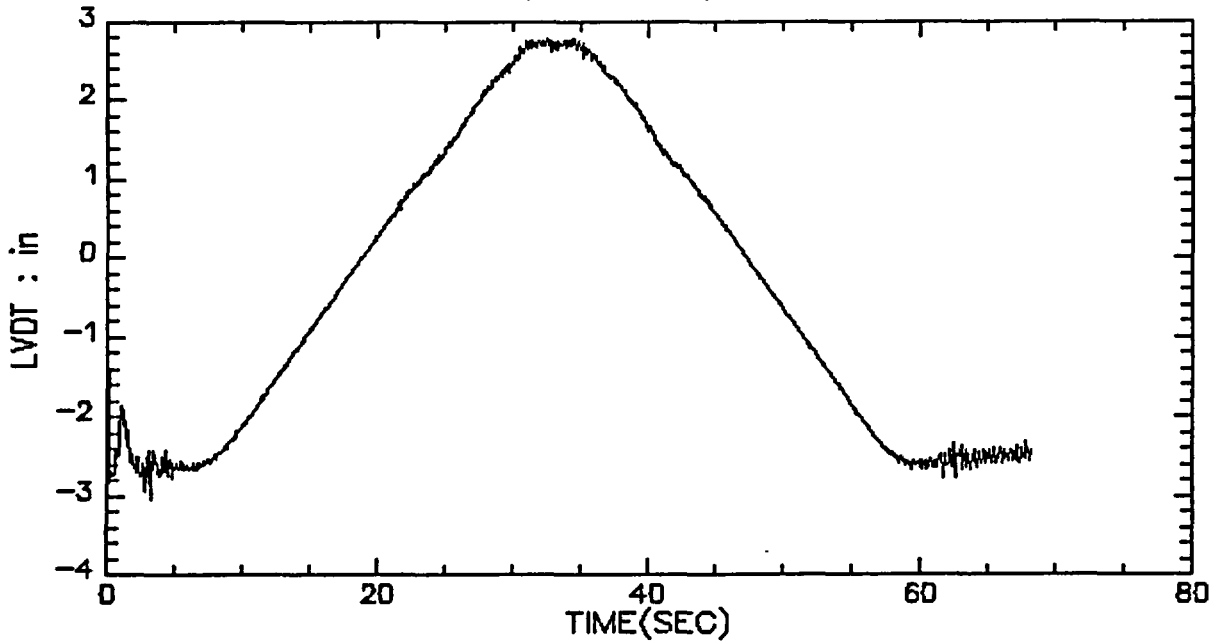

VALVE A, TEST 6, STEP 8&9

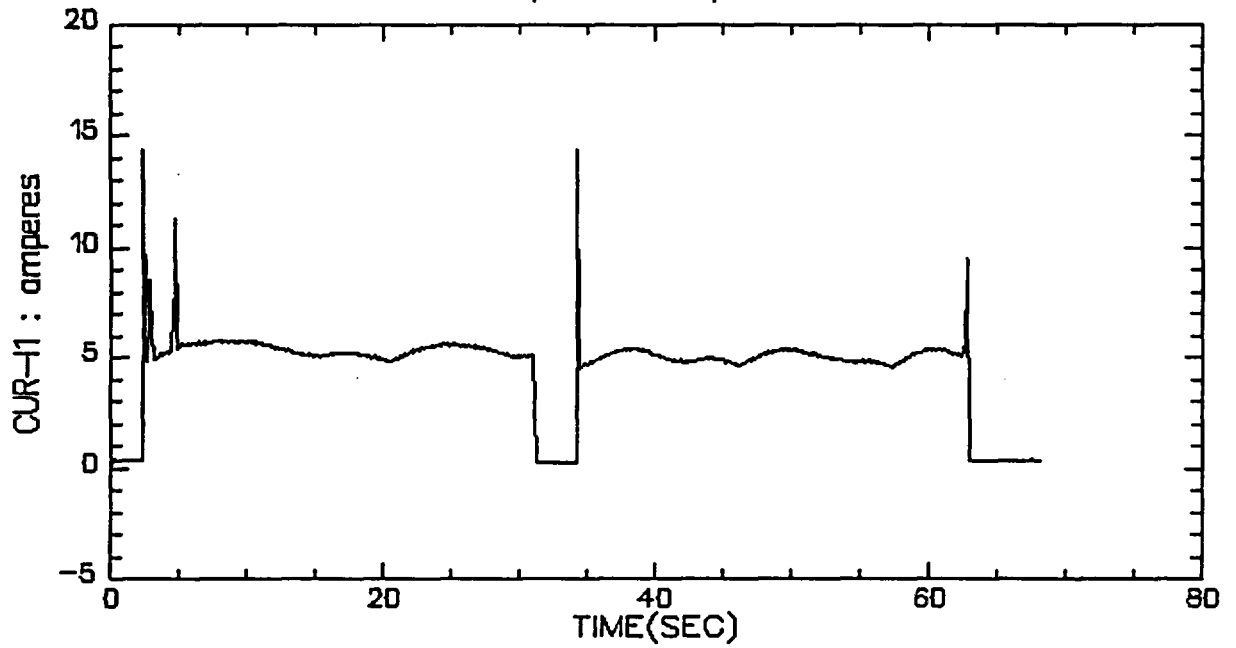

VALVE A, TEST 6, STEP 8&9

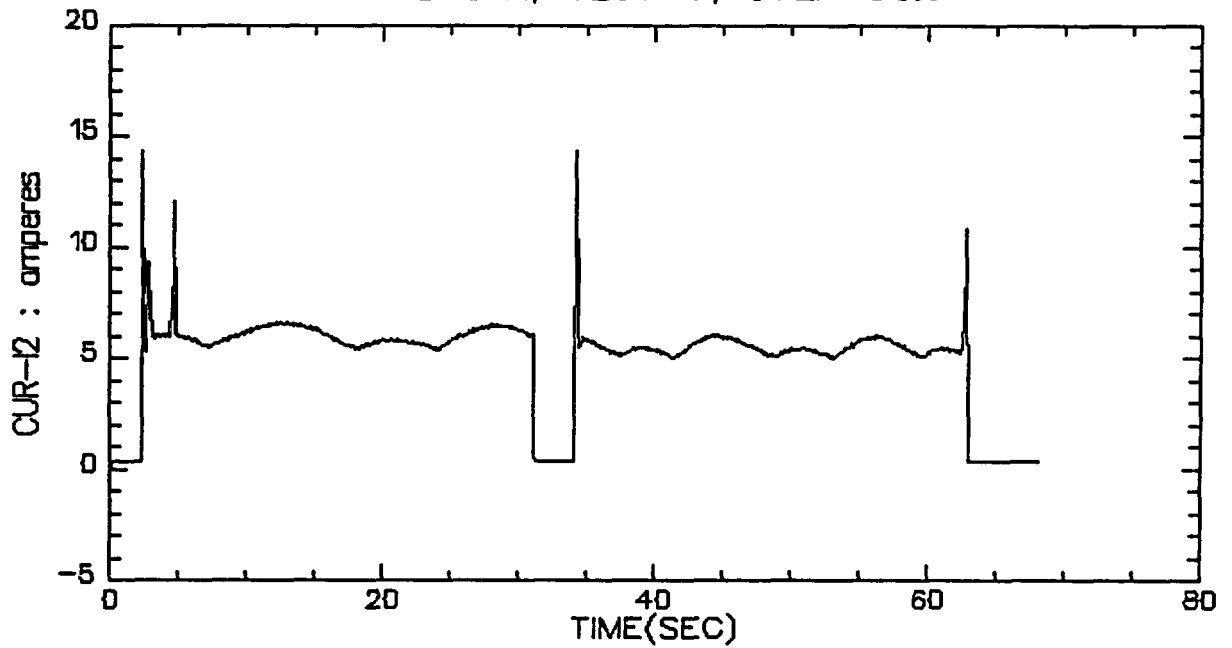

VALVE A, TEST 6, STEP 8&9

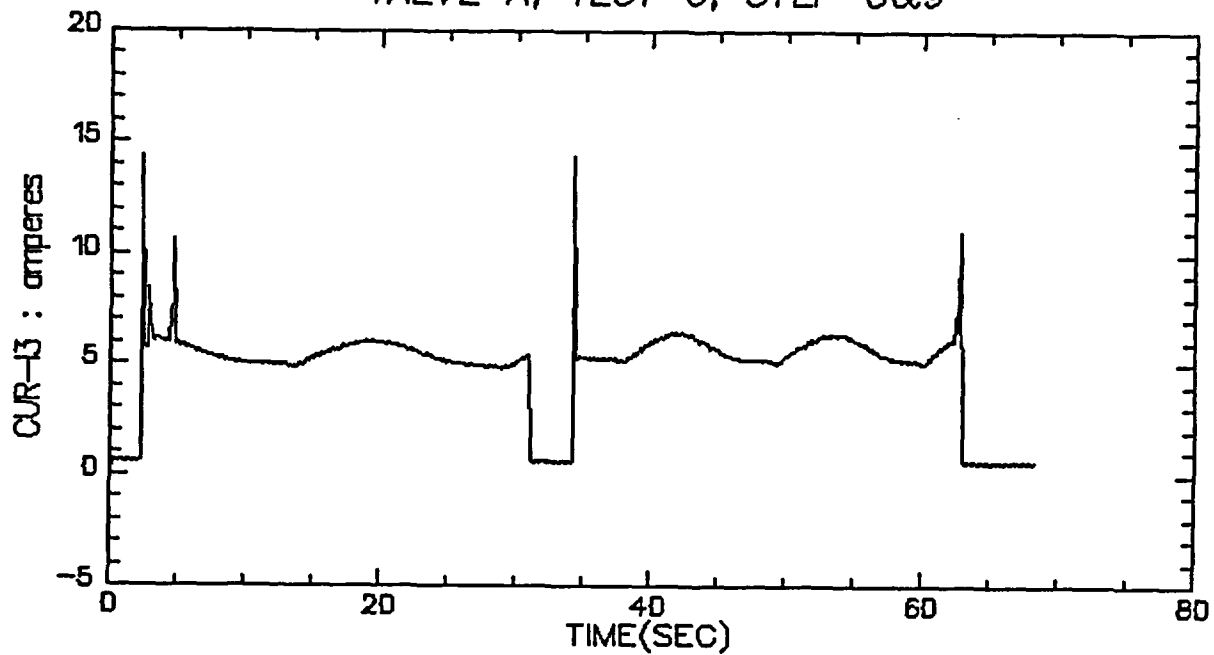

VALVE A, TEST 6, STEP 8&9

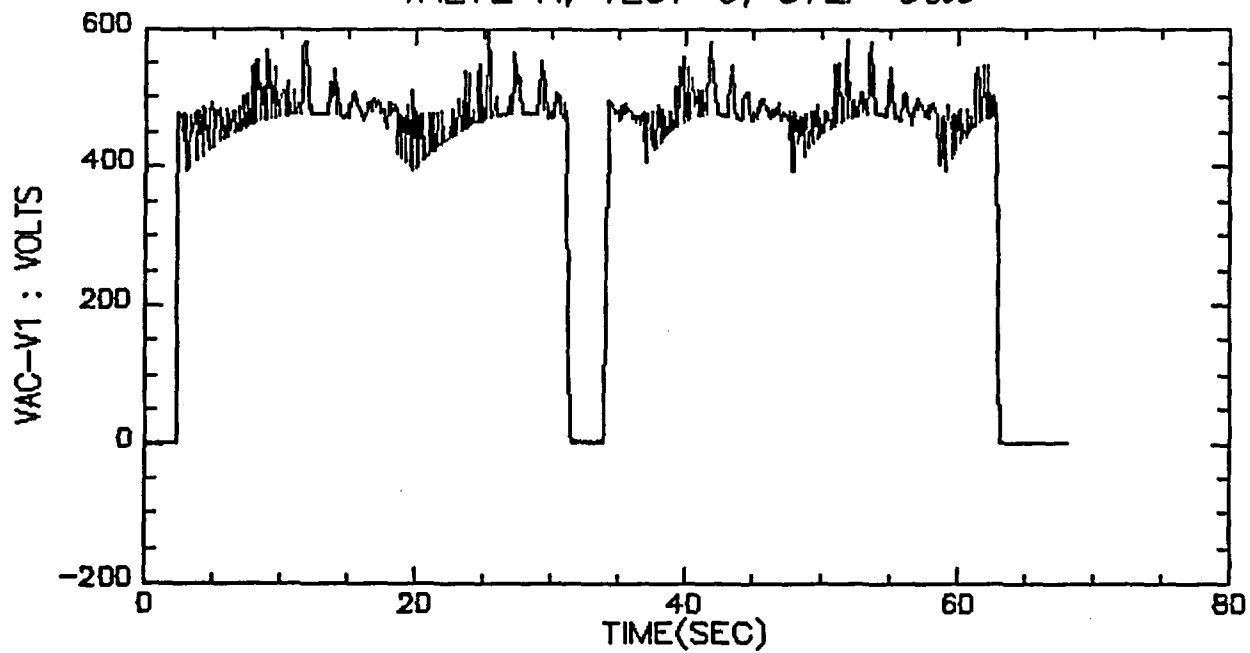

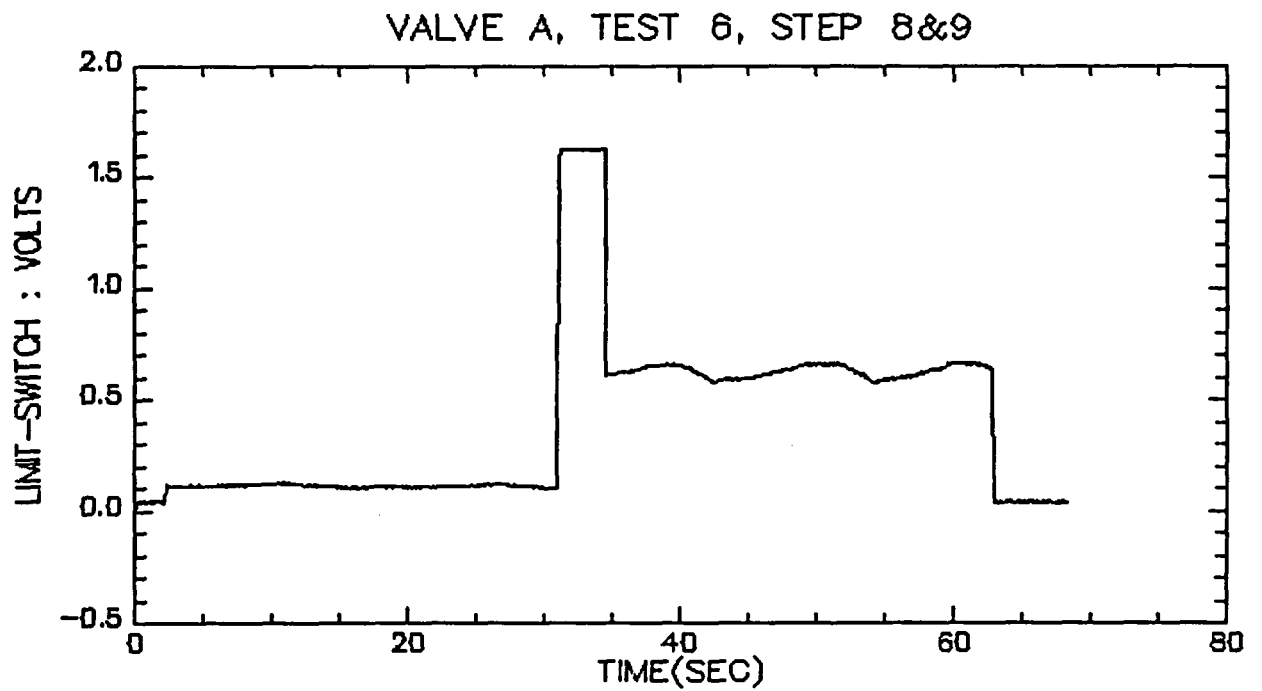
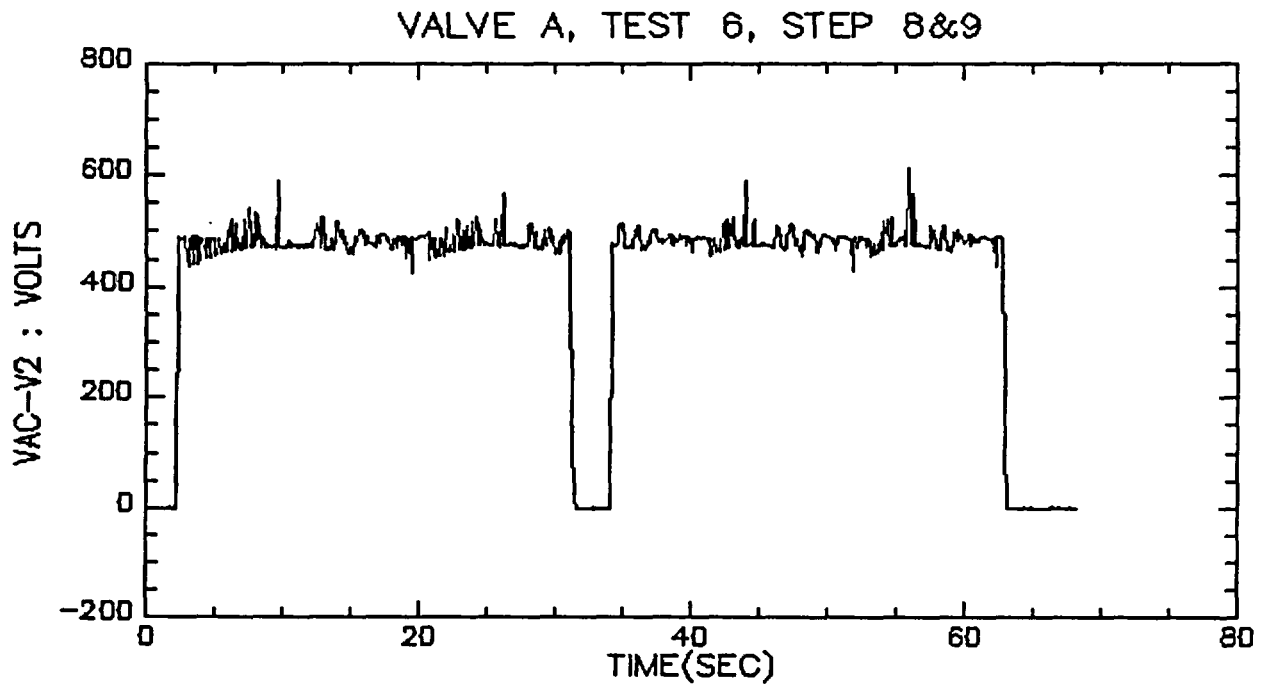

VALVE A, TEST 6, STEP 8&9

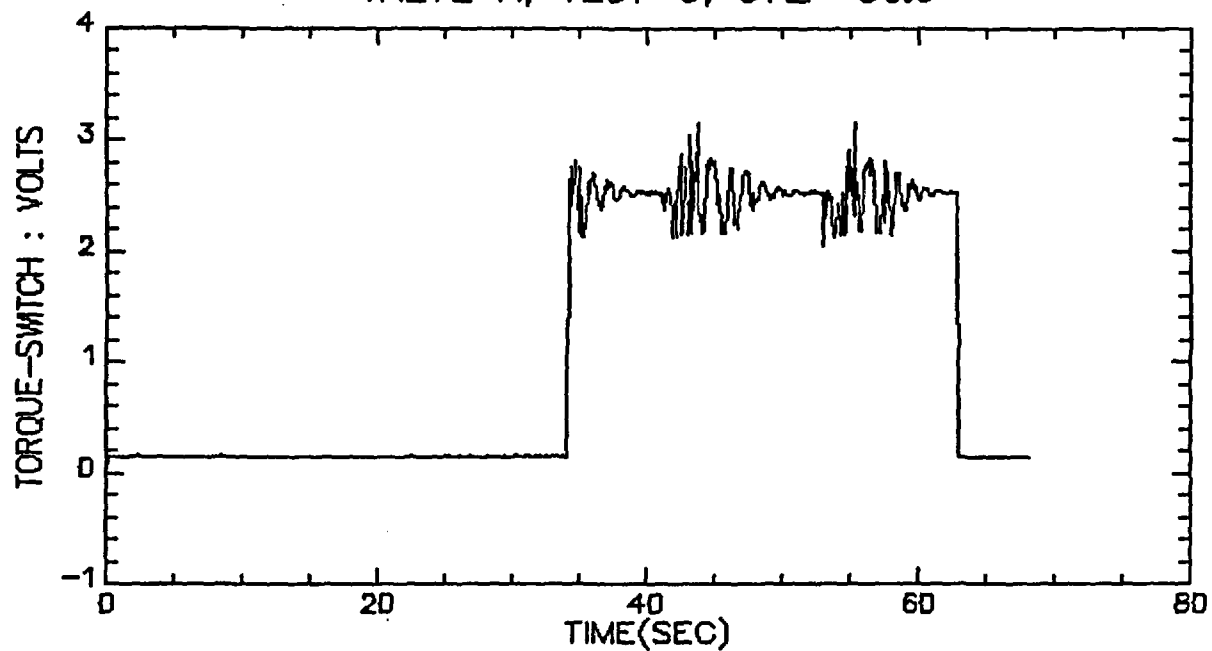

VALVE A, TEST 6, STEP 8&9

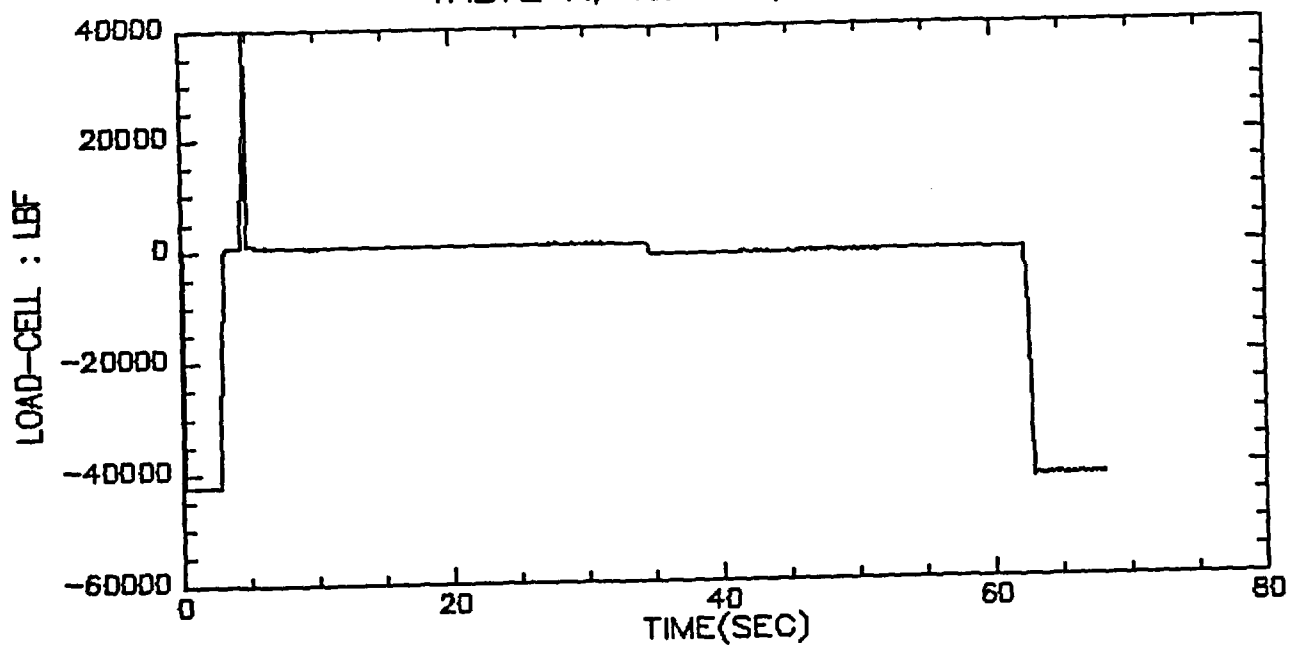

VALVE A, TEST 7 STEP 1

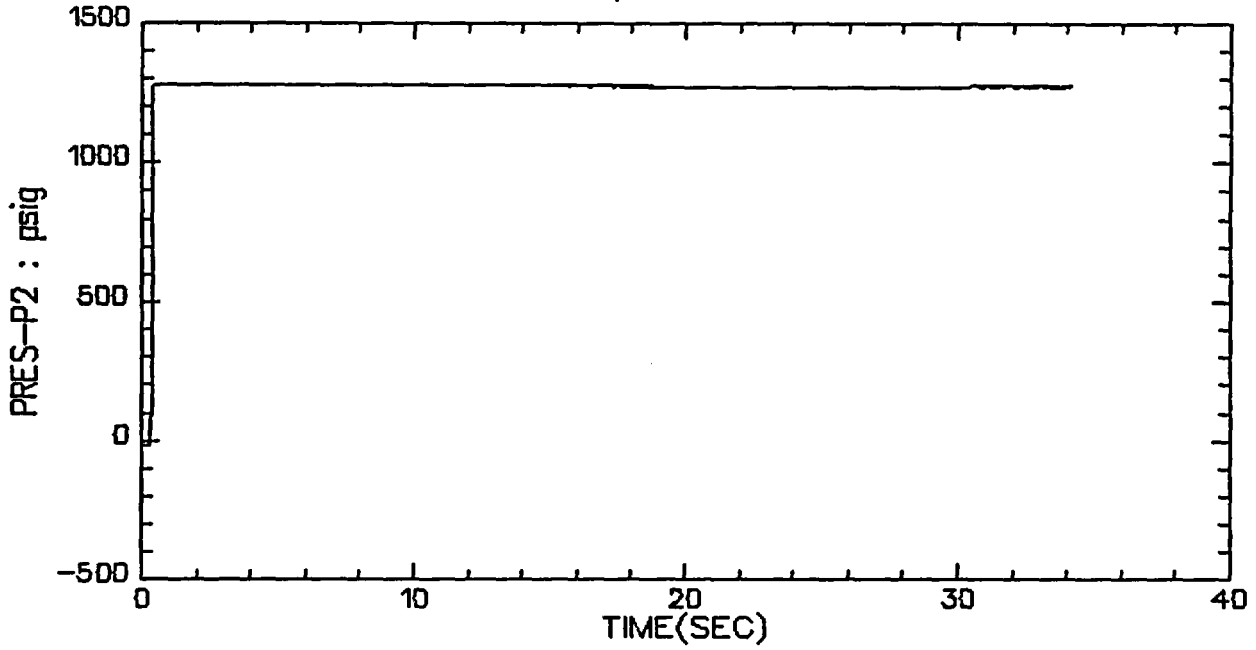

VALVE A, TEST 7, STEP 1

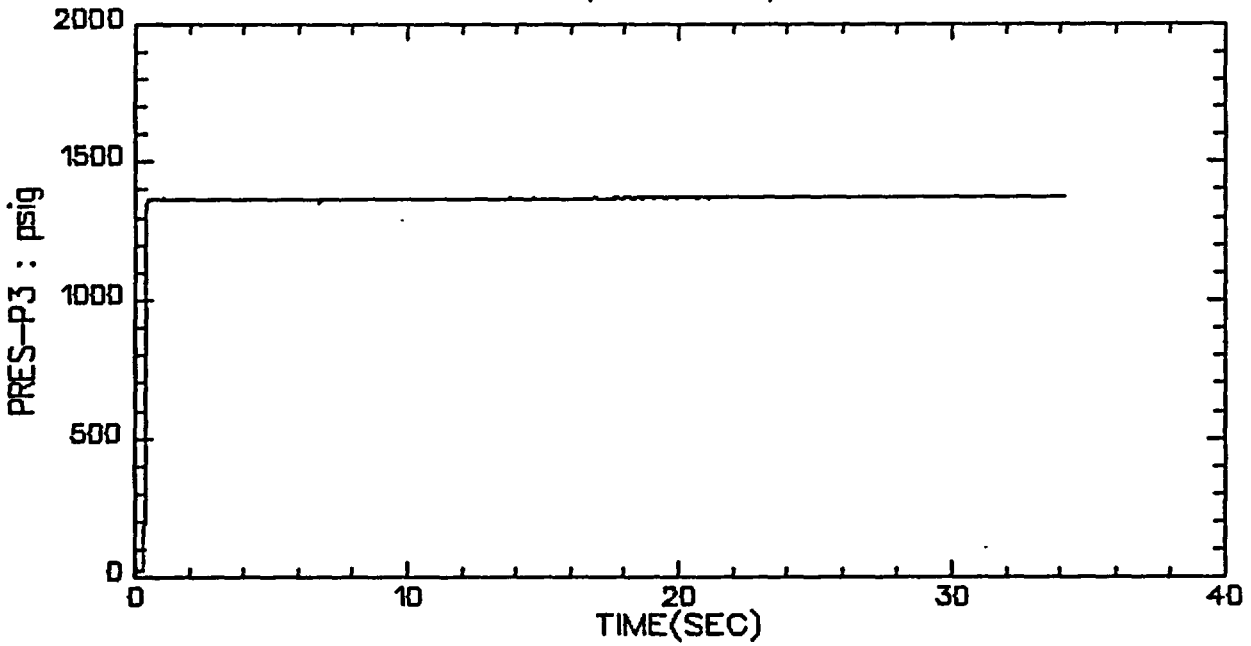

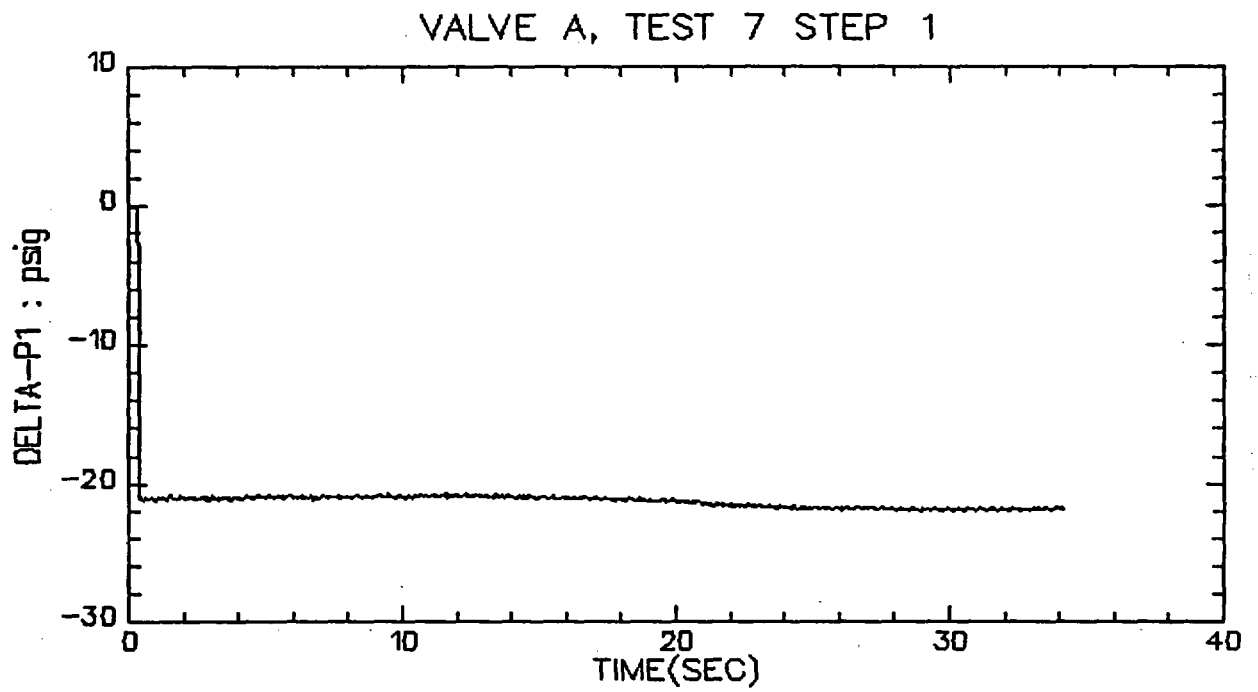
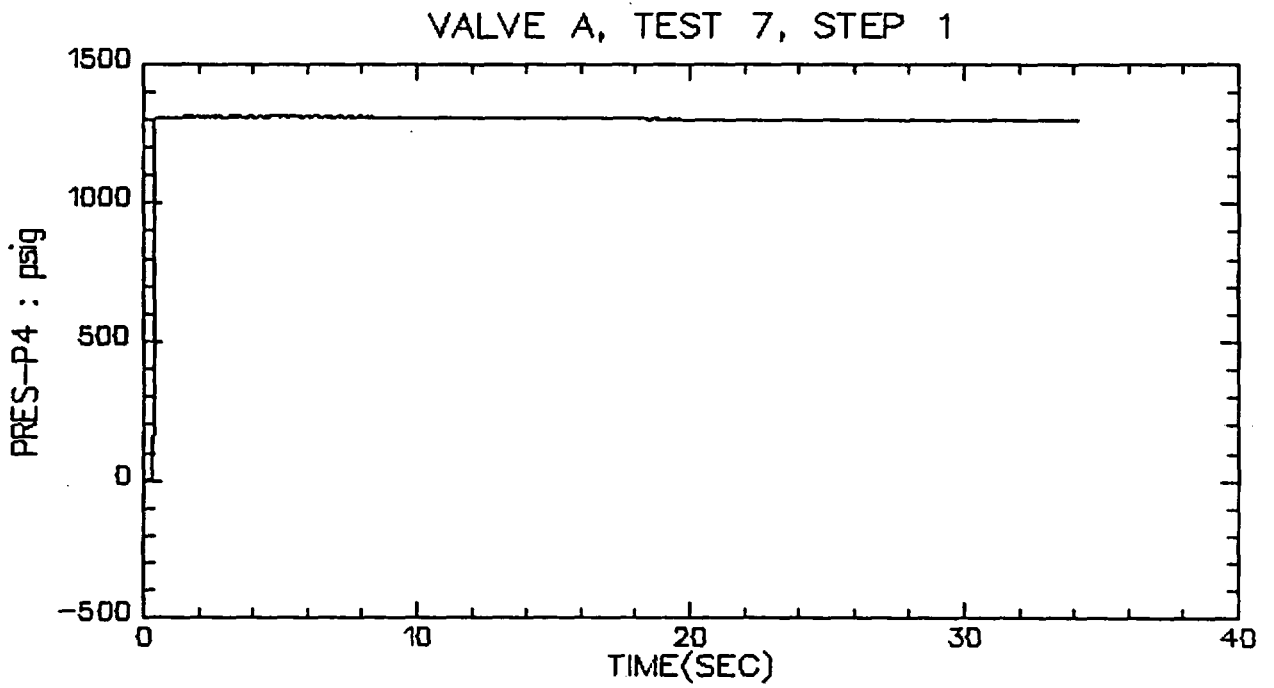

VALVE A, TEST 7, STEP 1

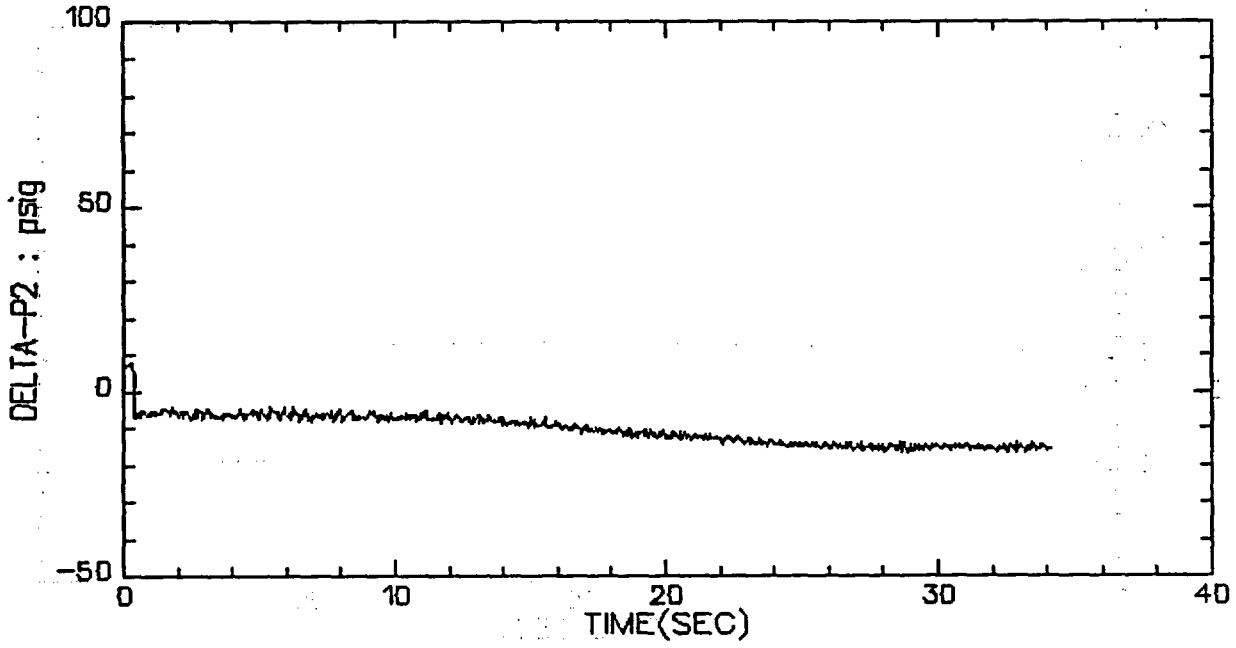

VALVE A, TEST 7, STEP 1

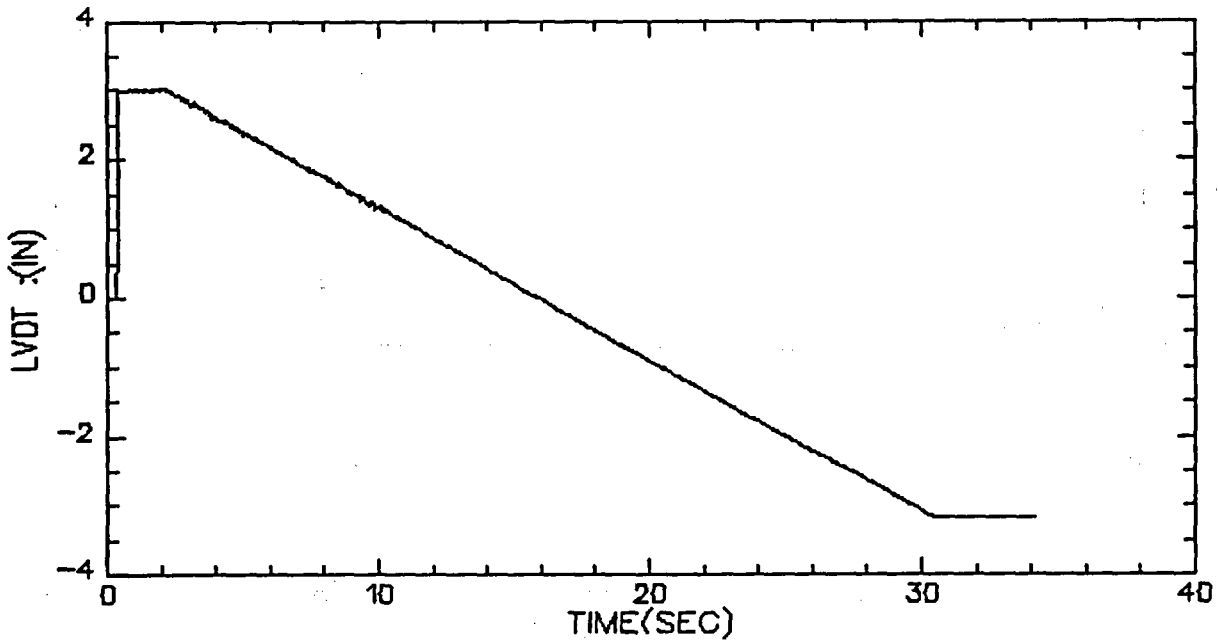

VALVE A, TEST 7, STEP 1

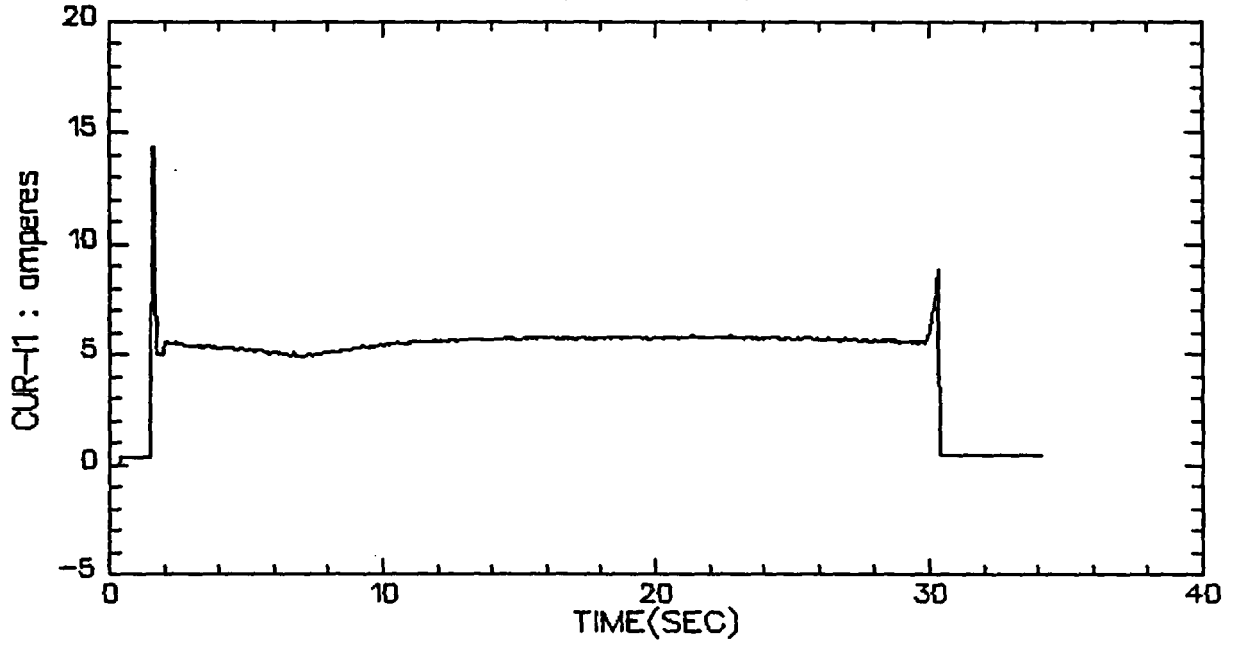

VALVE A, TEST 7, STEP 1

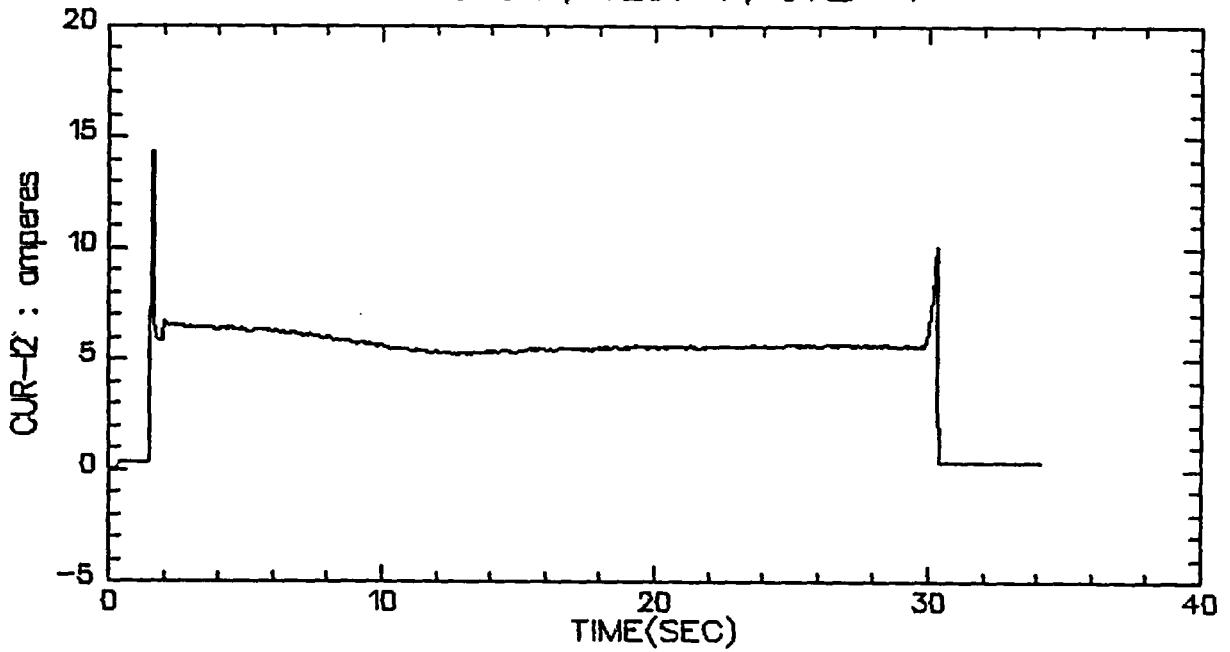

VALVE A, TEST 7, STEP 1

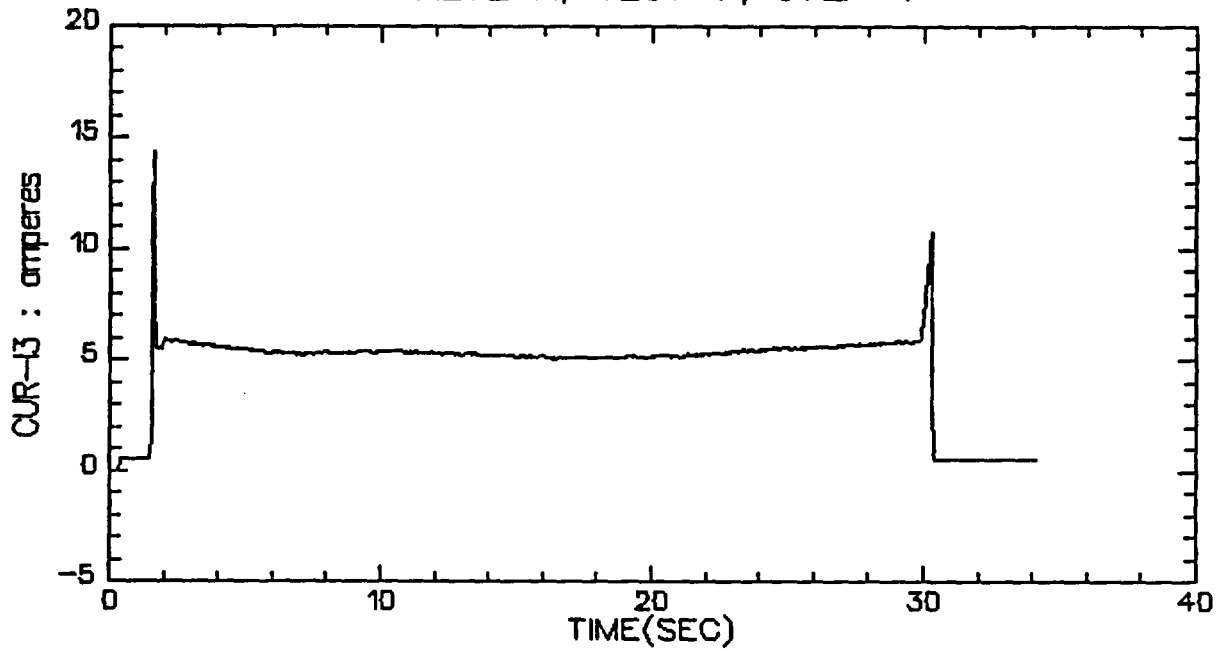

VALVE A, TEST 7, STEP 1

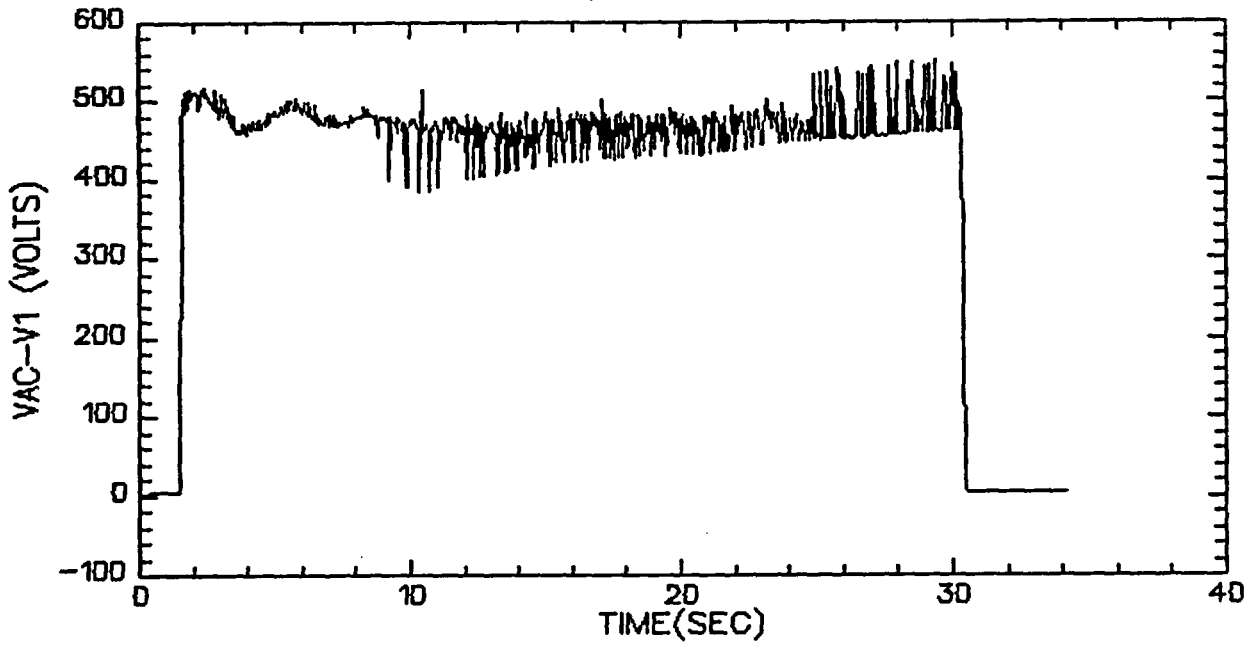

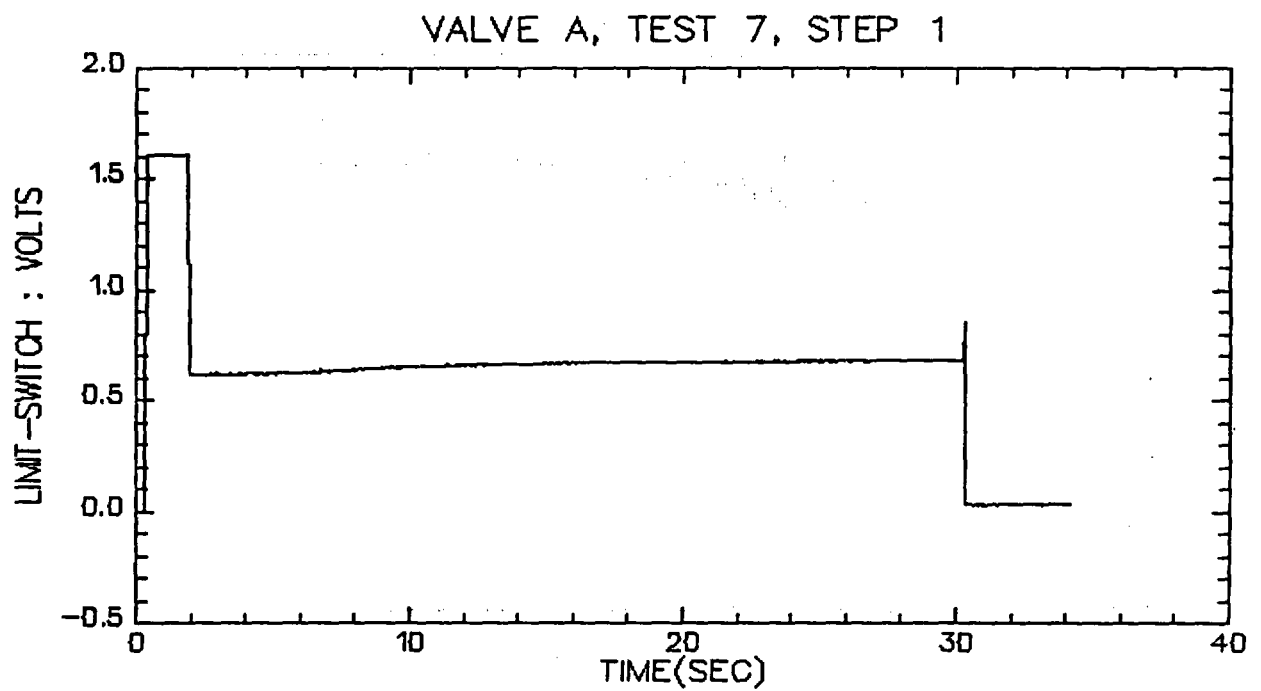
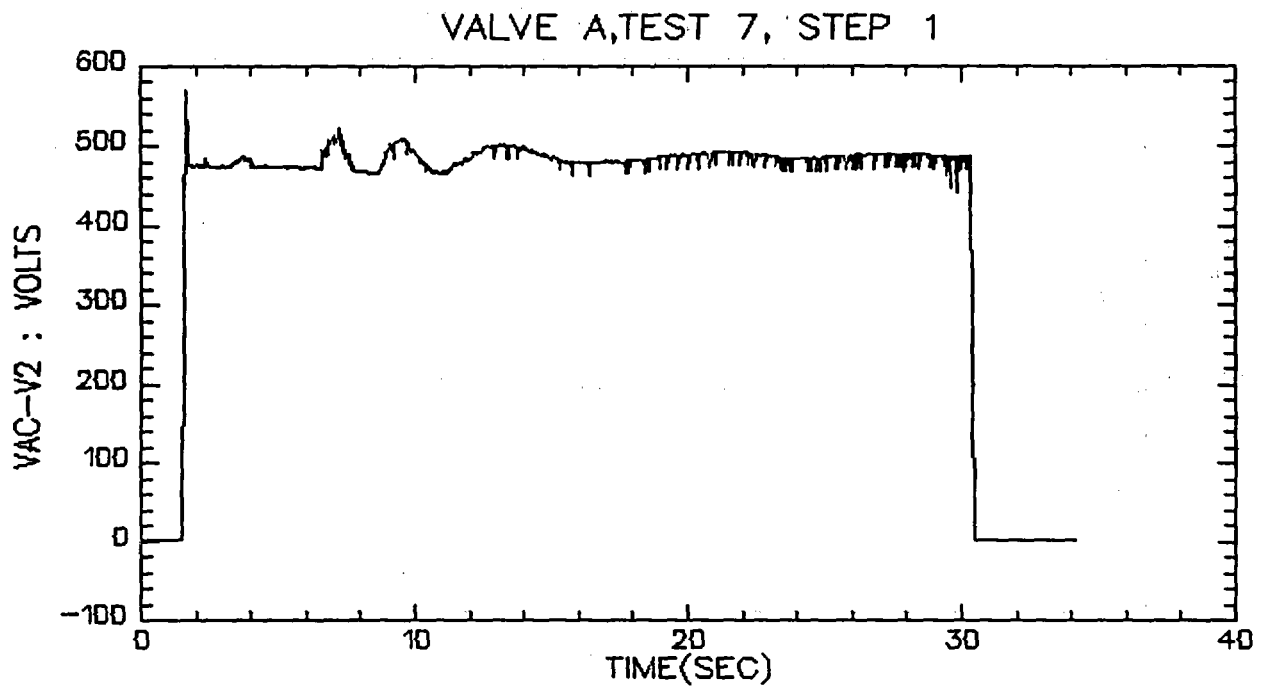

VALVE A, TEST 7, STEP 1

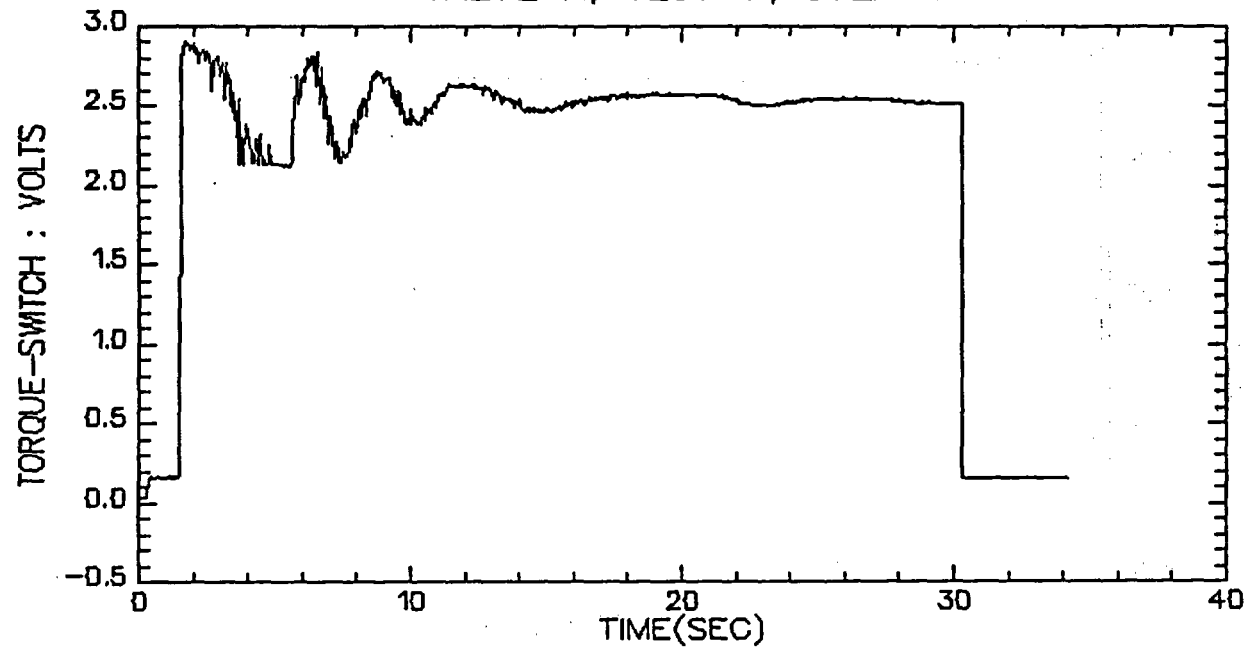

VALVE A, TEST 7, STEP 1

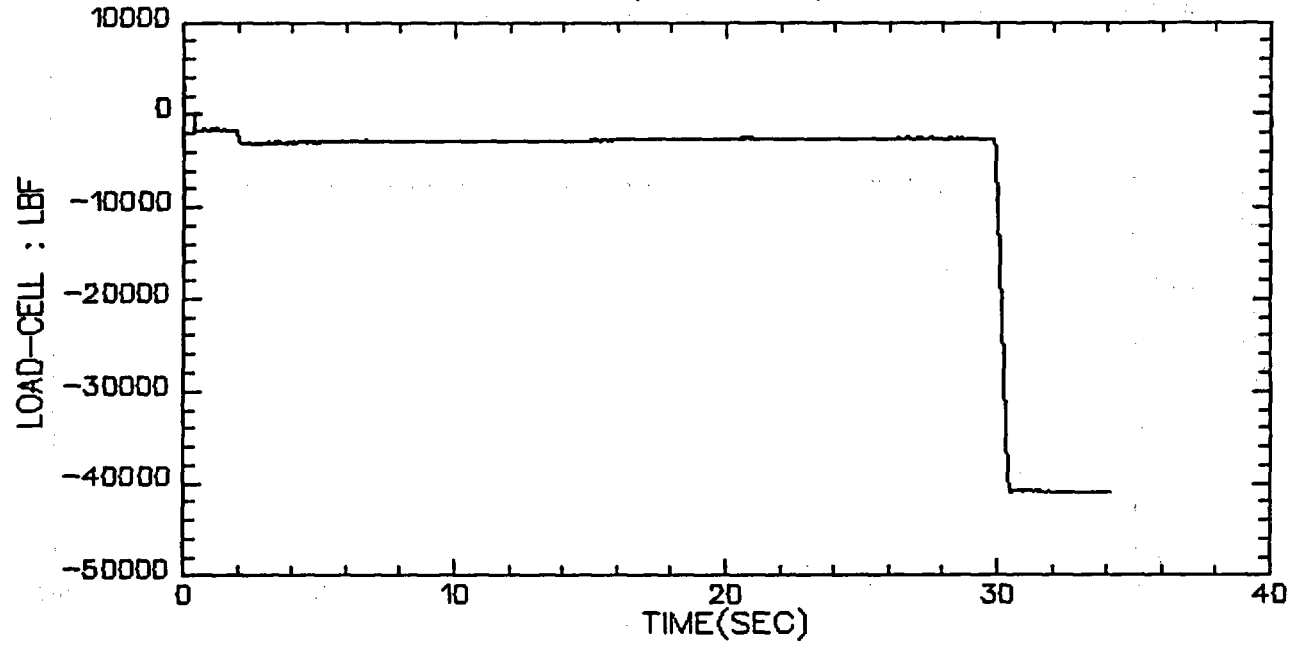

VALVE A, TEST 7, STEP 2

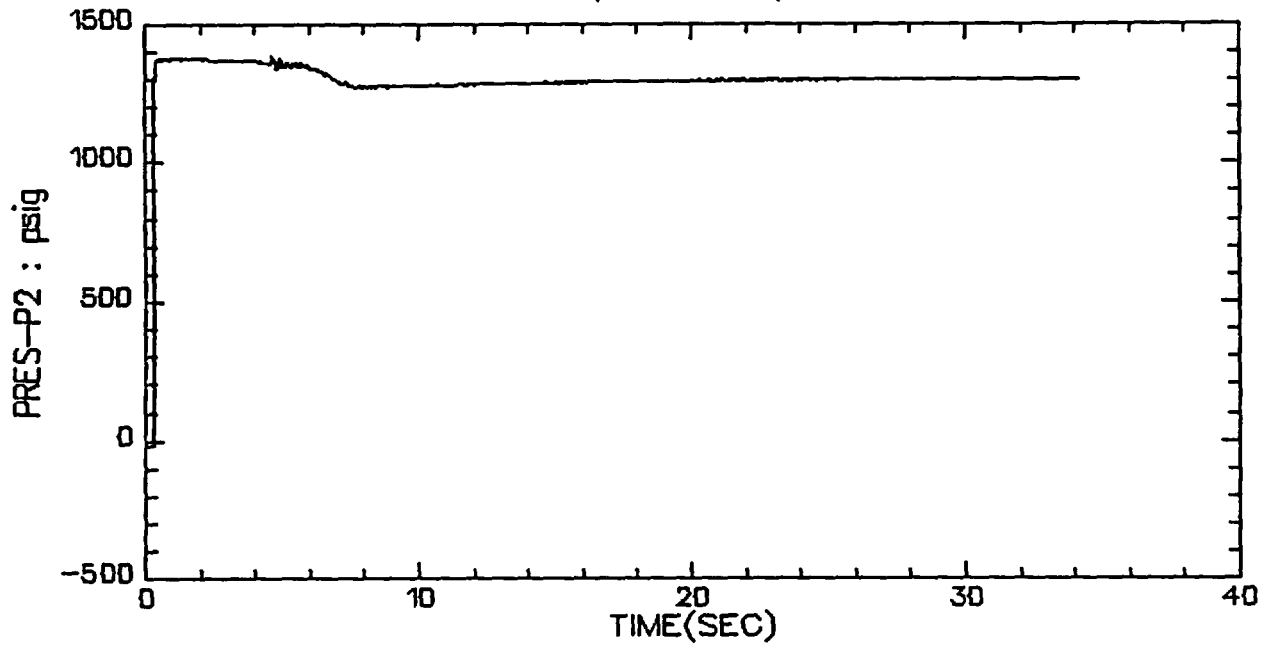

VALVE A, TEST 7, STEP 2

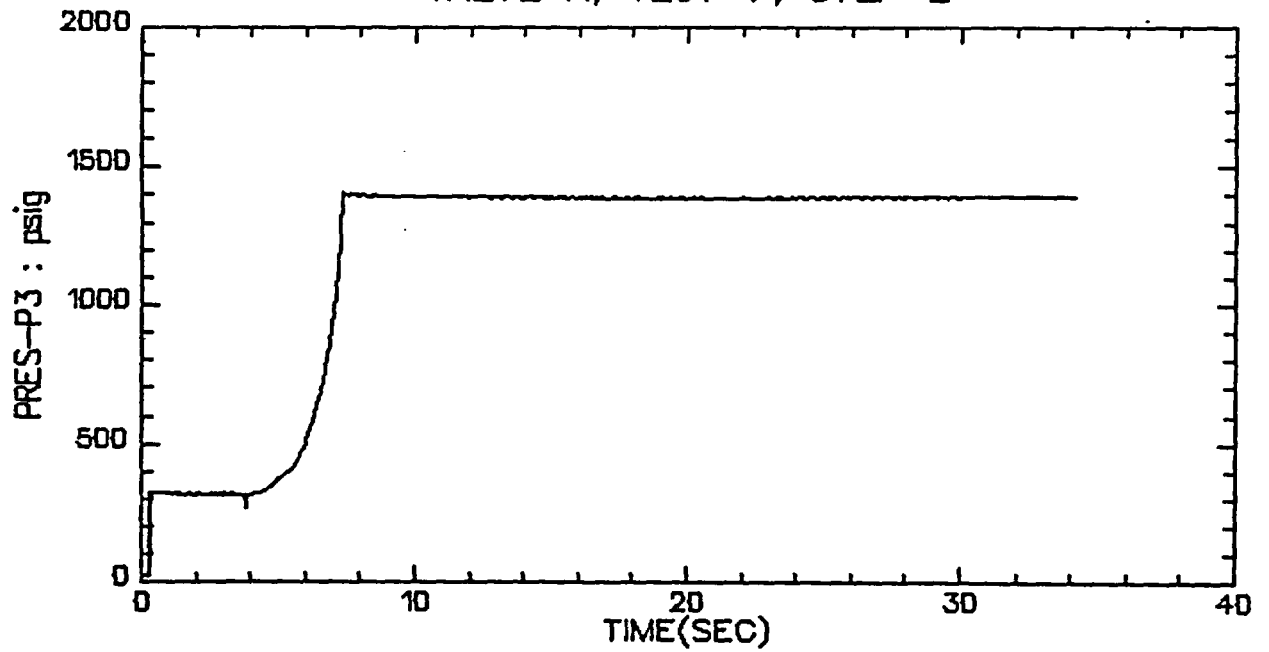

VALVE A, TEST 7, STEP 2

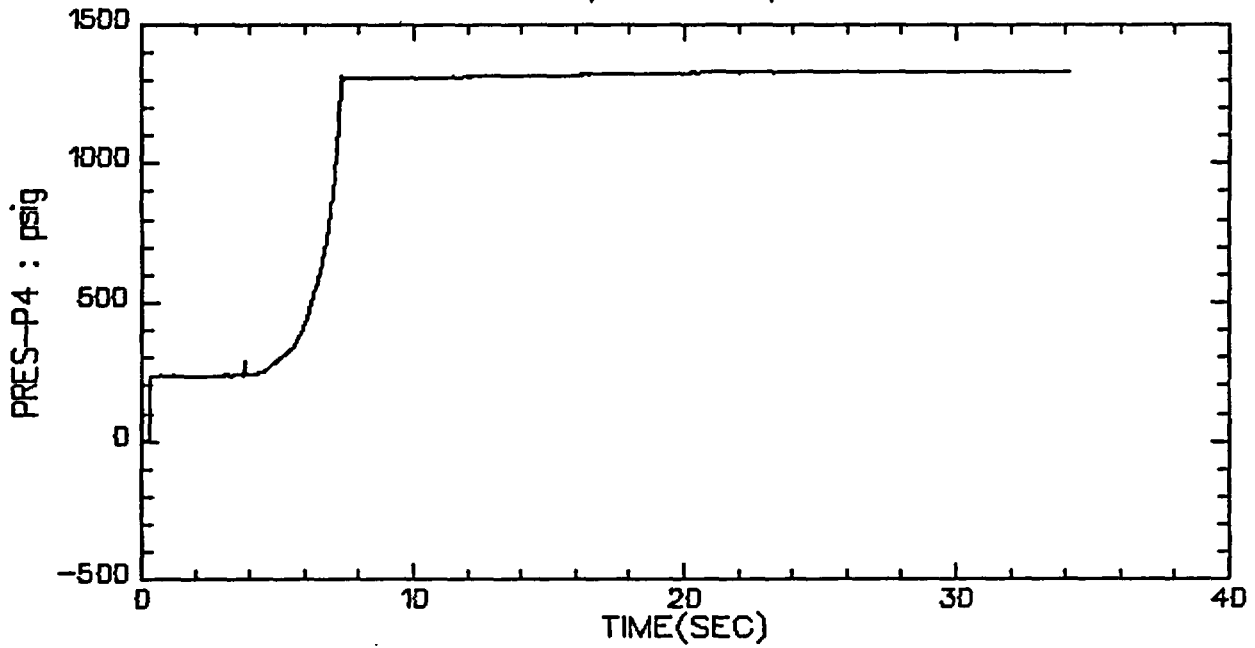

VALVE A, TEST 7, STEP 2

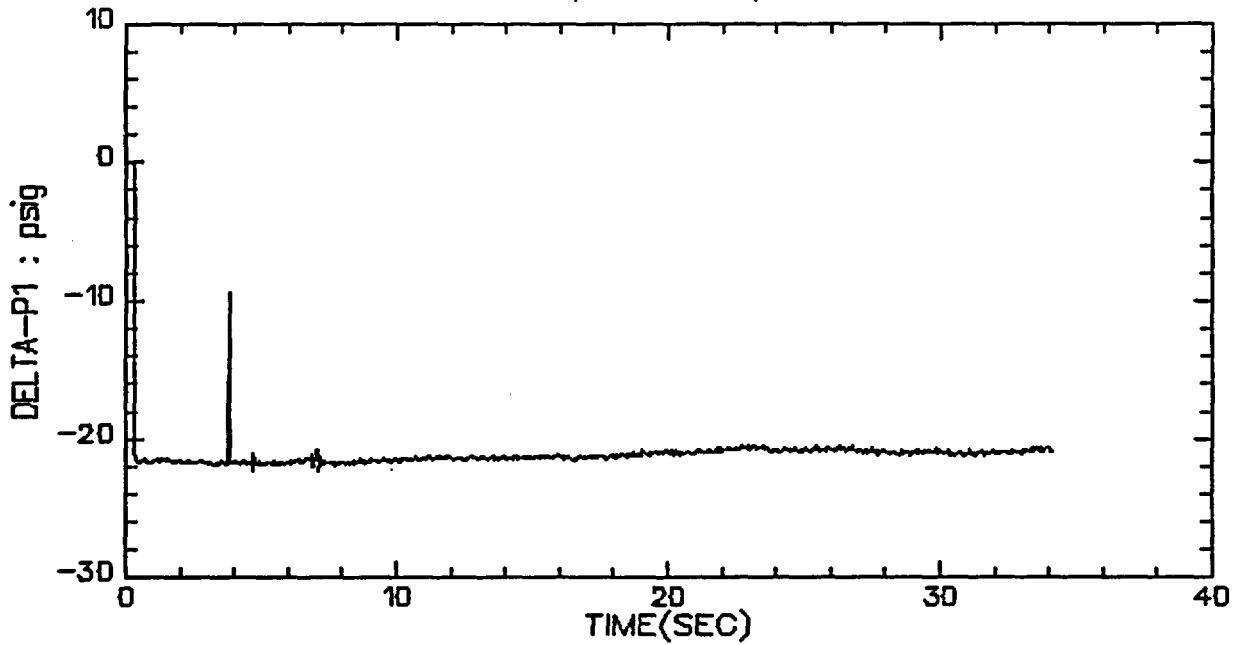

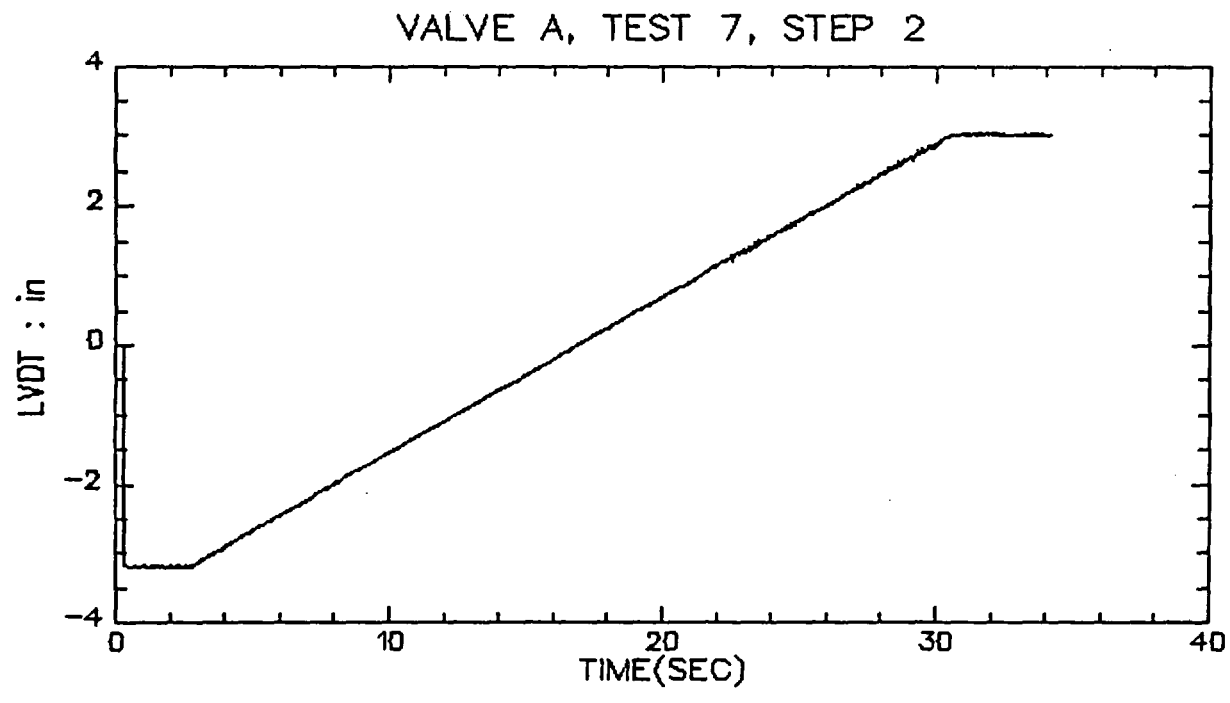
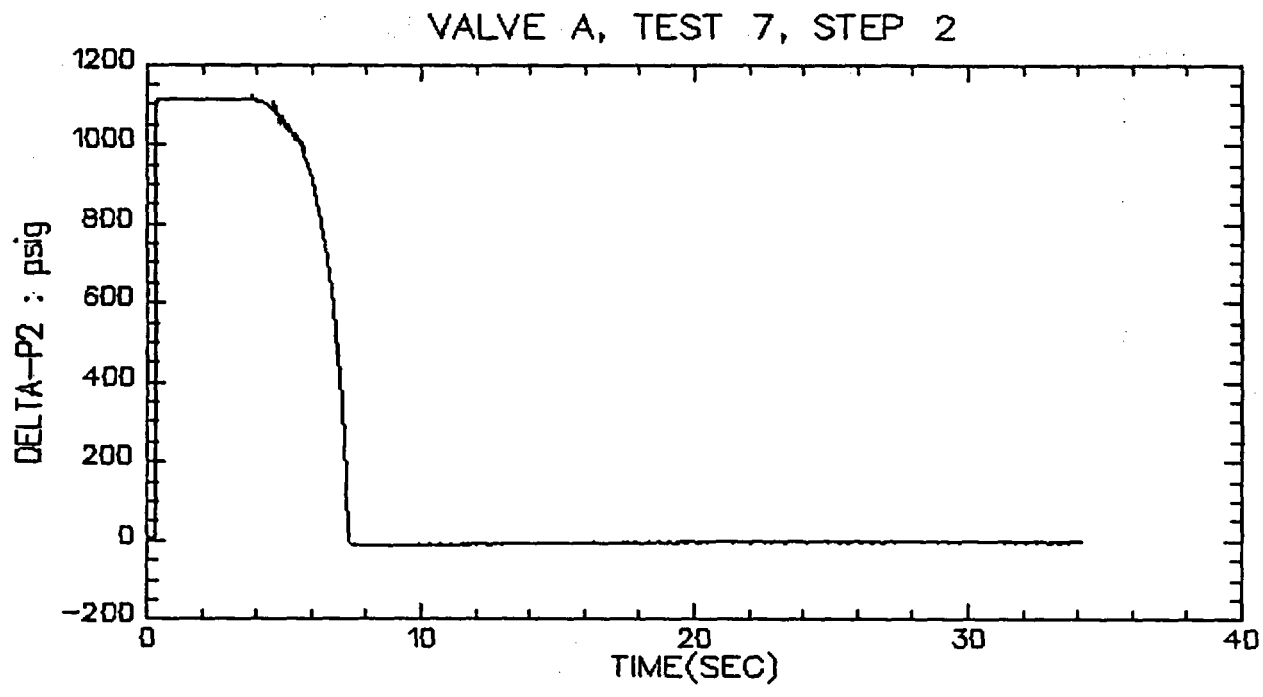

VALVE A, TEST 7, STEP 2

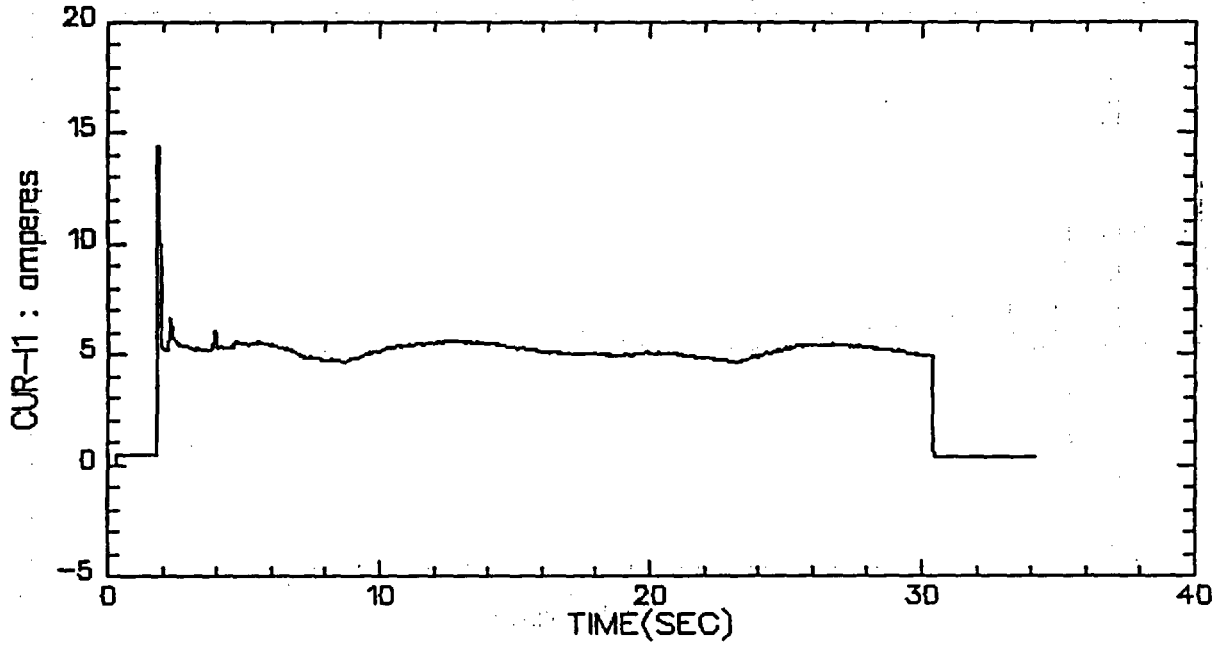

VALVE A, TEST 7, STEP 2

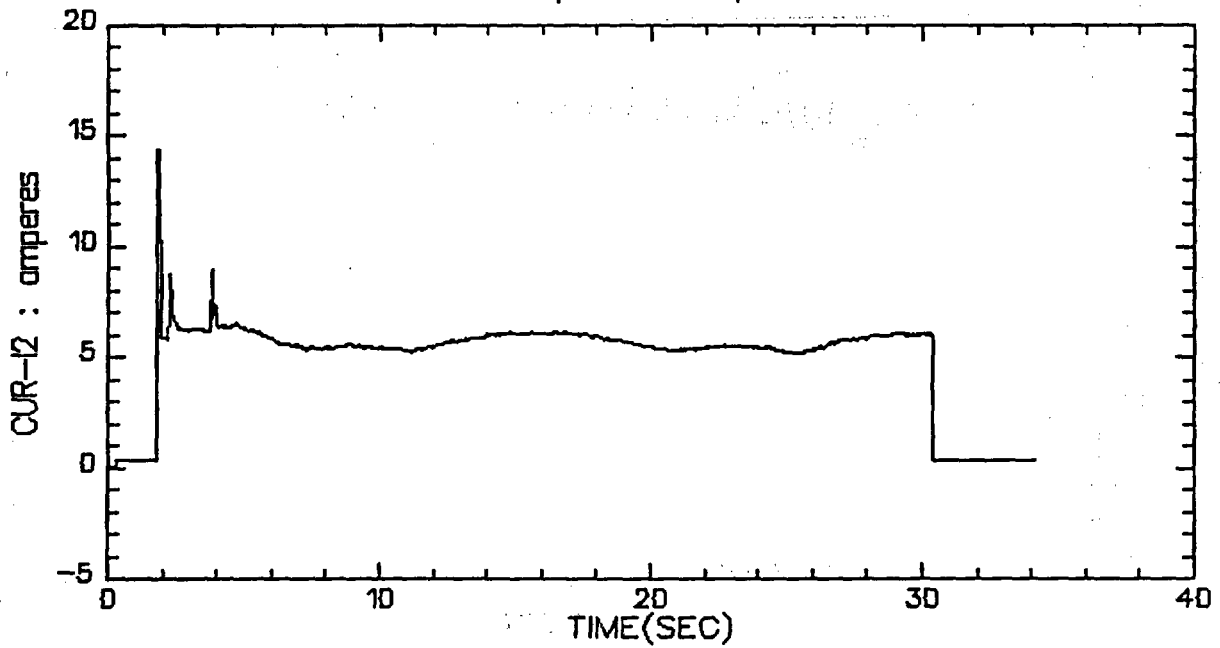

VALVE A, TEST 7, STEP 2

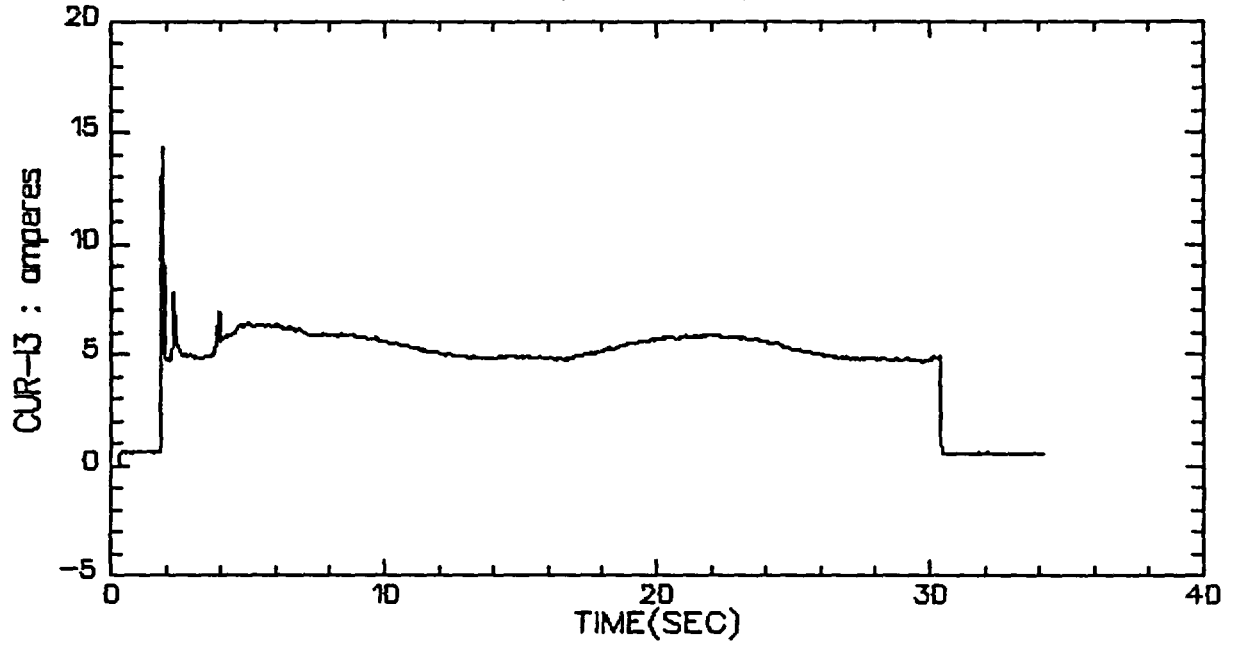

VALVE A, TEST 7, STEP 2

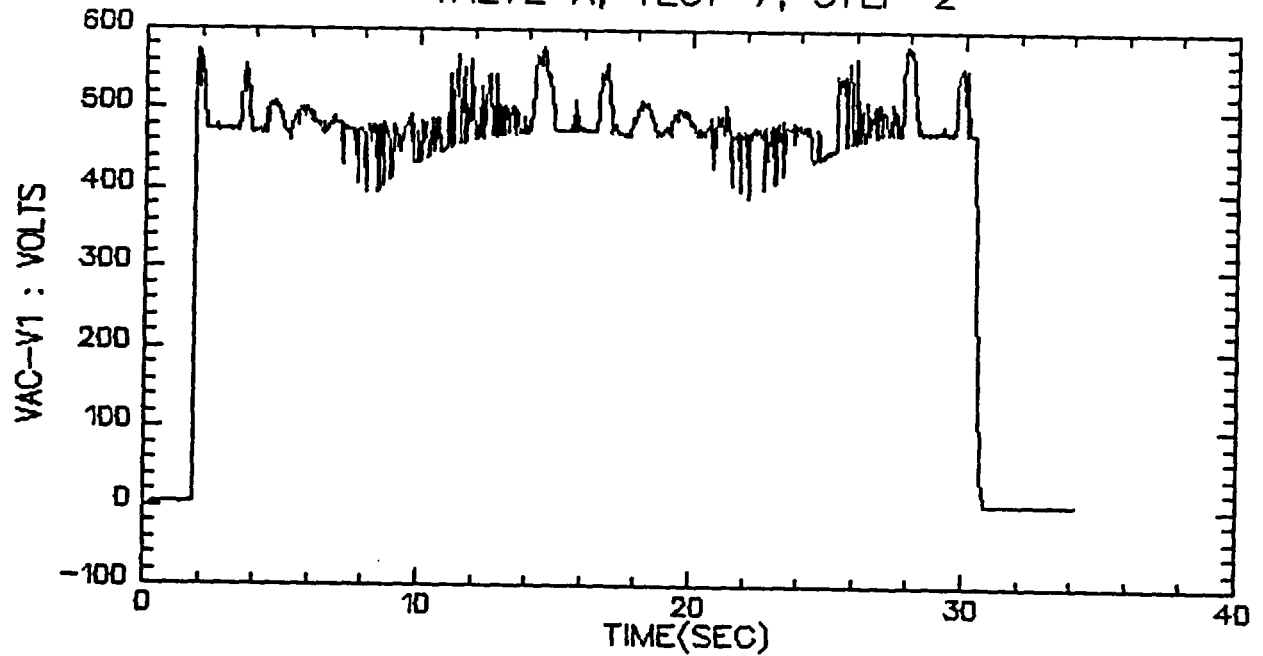

VALVE A, TEST 7, STEP 2

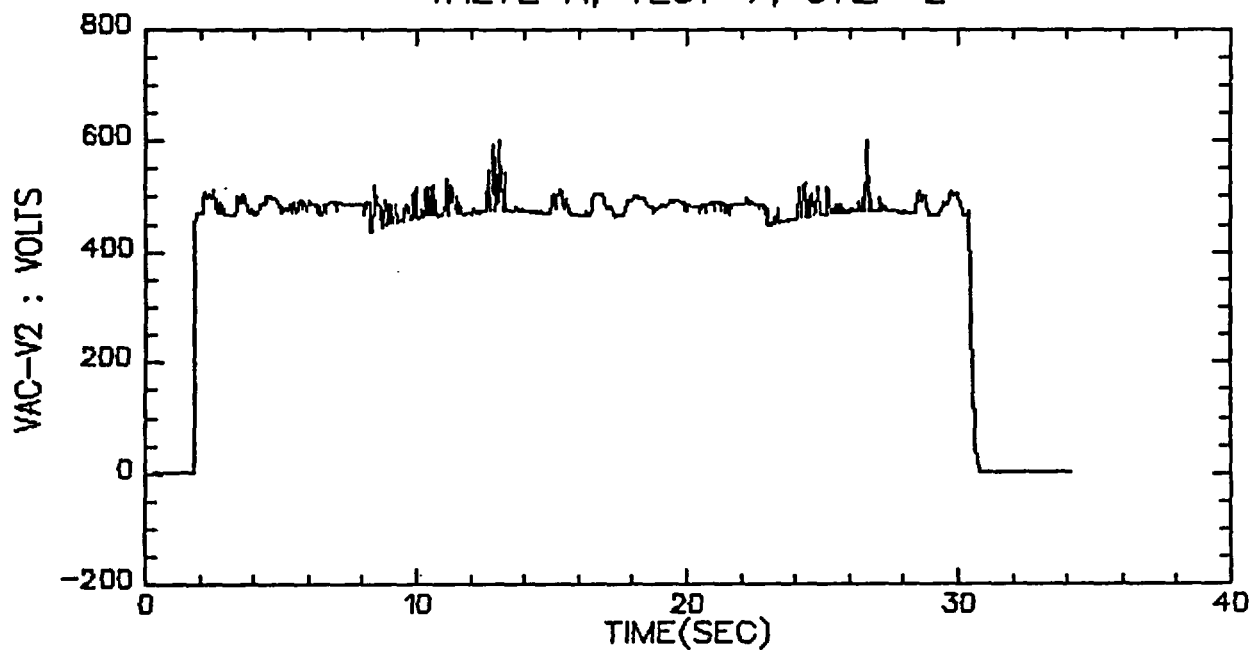

VALVE A, TEST 7, STEP 2

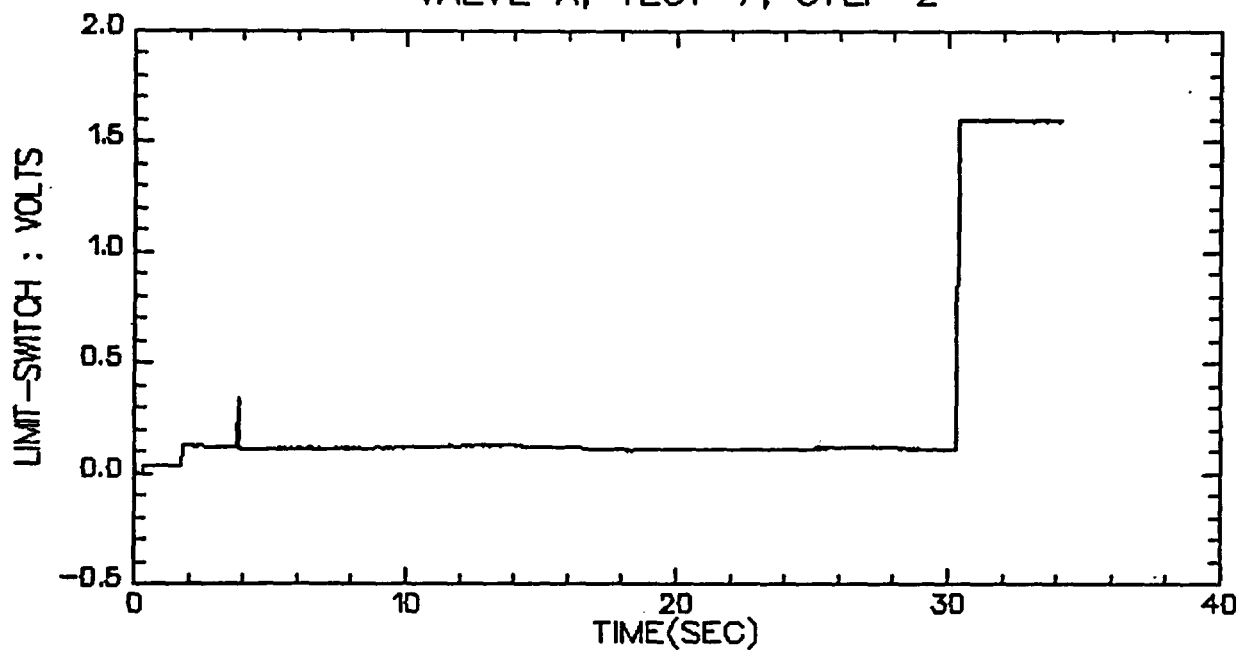

VALVE A, TEST 7, STEP 2

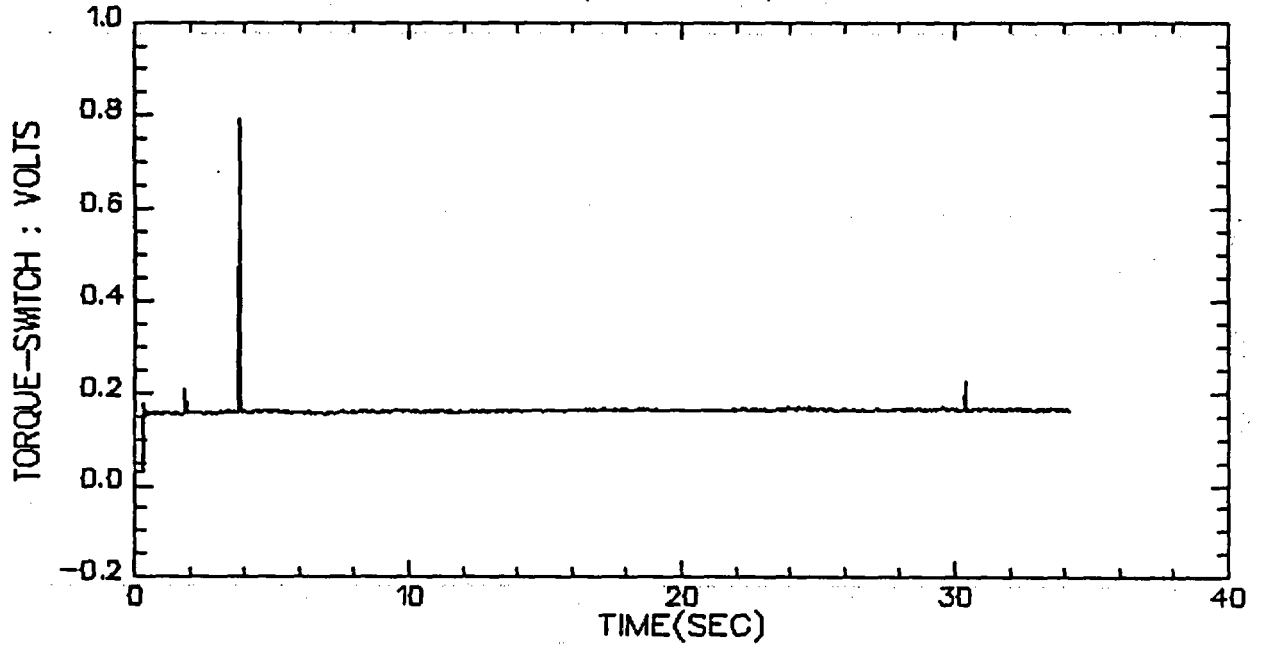

VALVE A, TEST 7, STEP 2

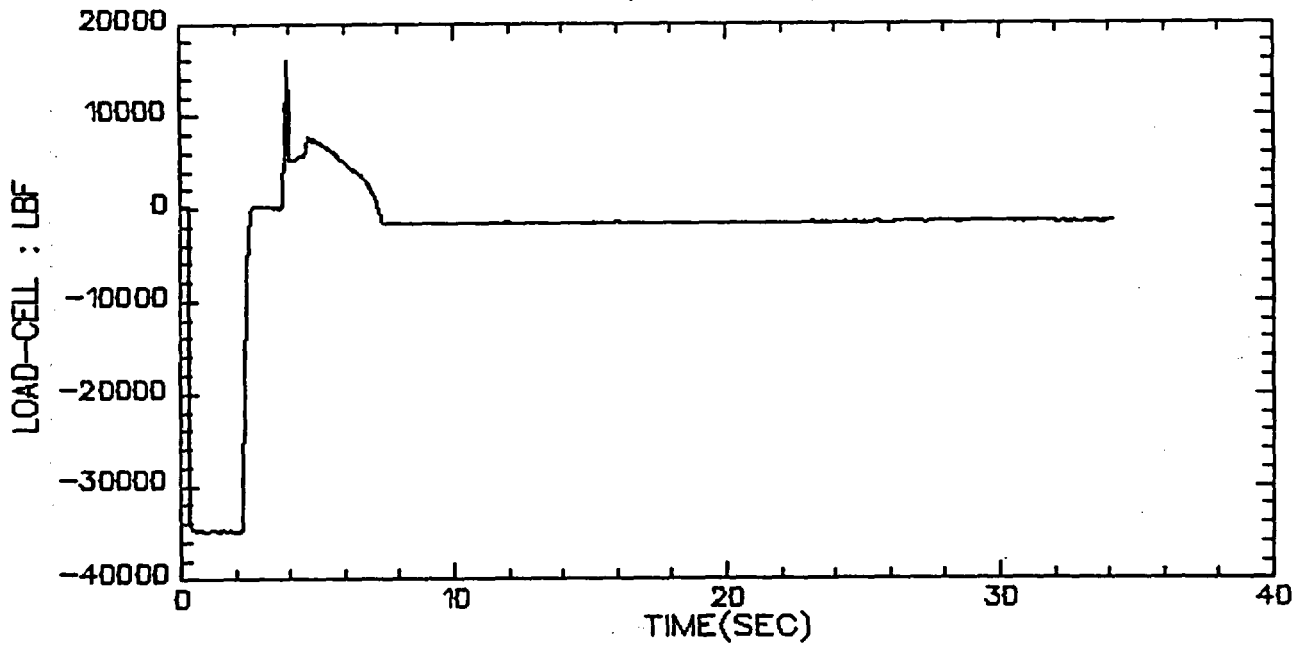

VALVE A, TEST 7, STEP 3&4

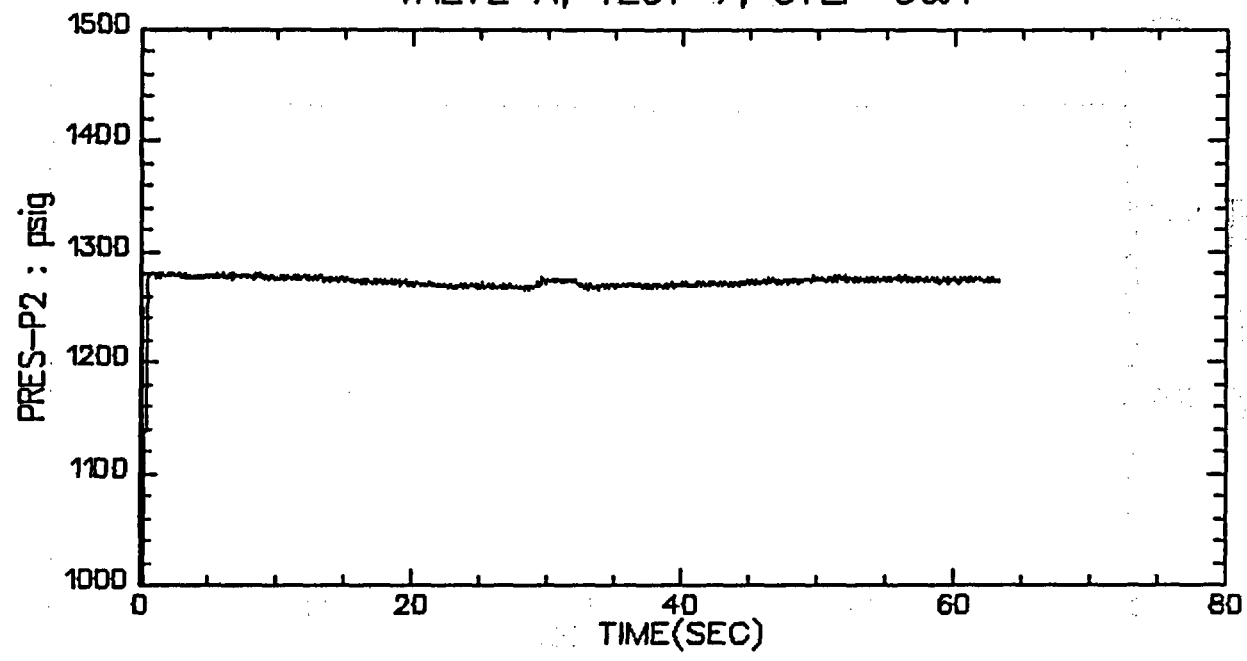

VALVE A, TEST 7, STEP 3&4

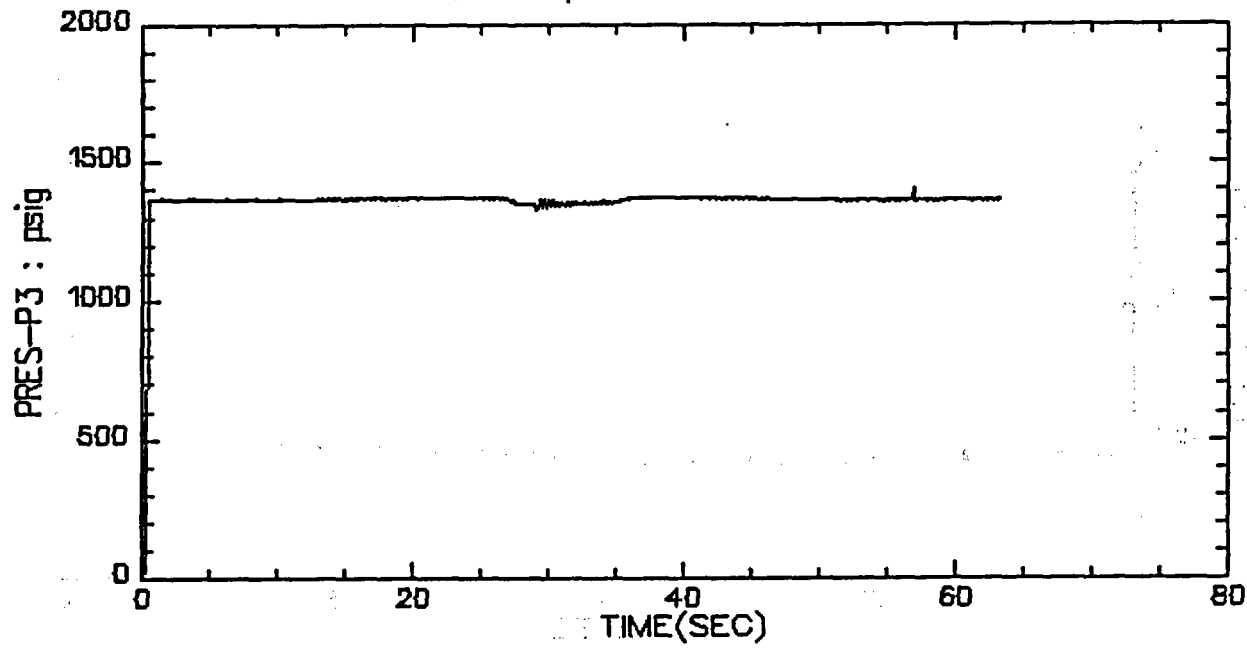

VALVE A, TEST 7, STEP 3&4

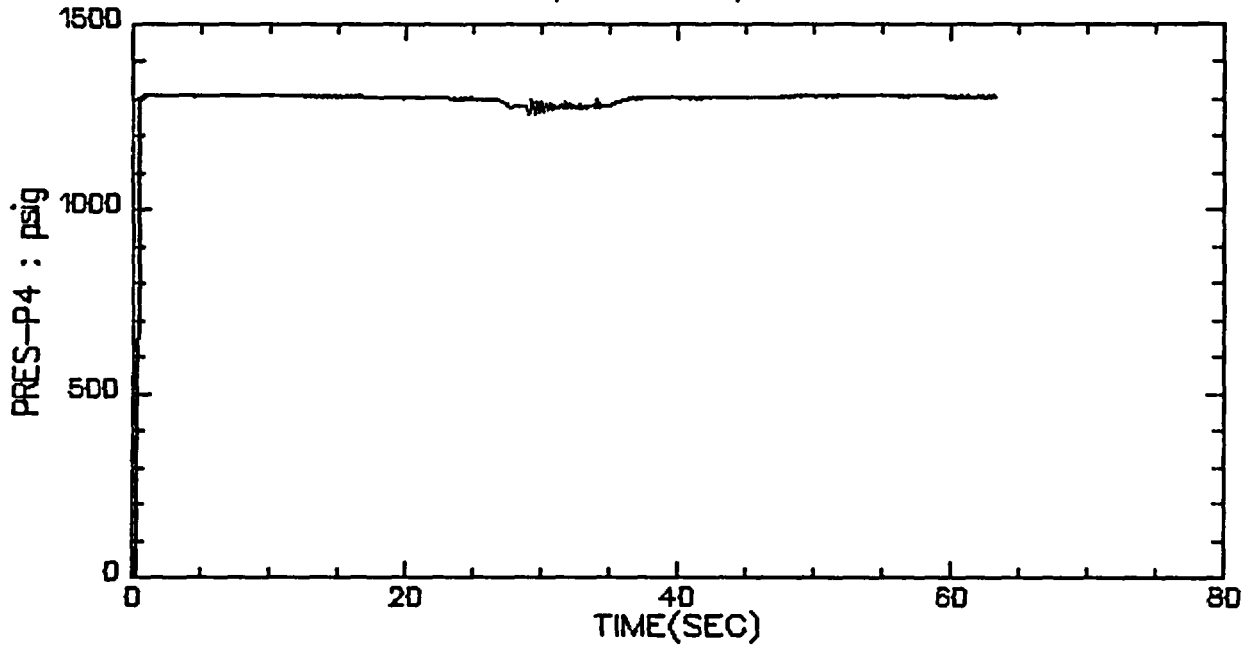

VALVE A, TEST 7, STEP 3&4

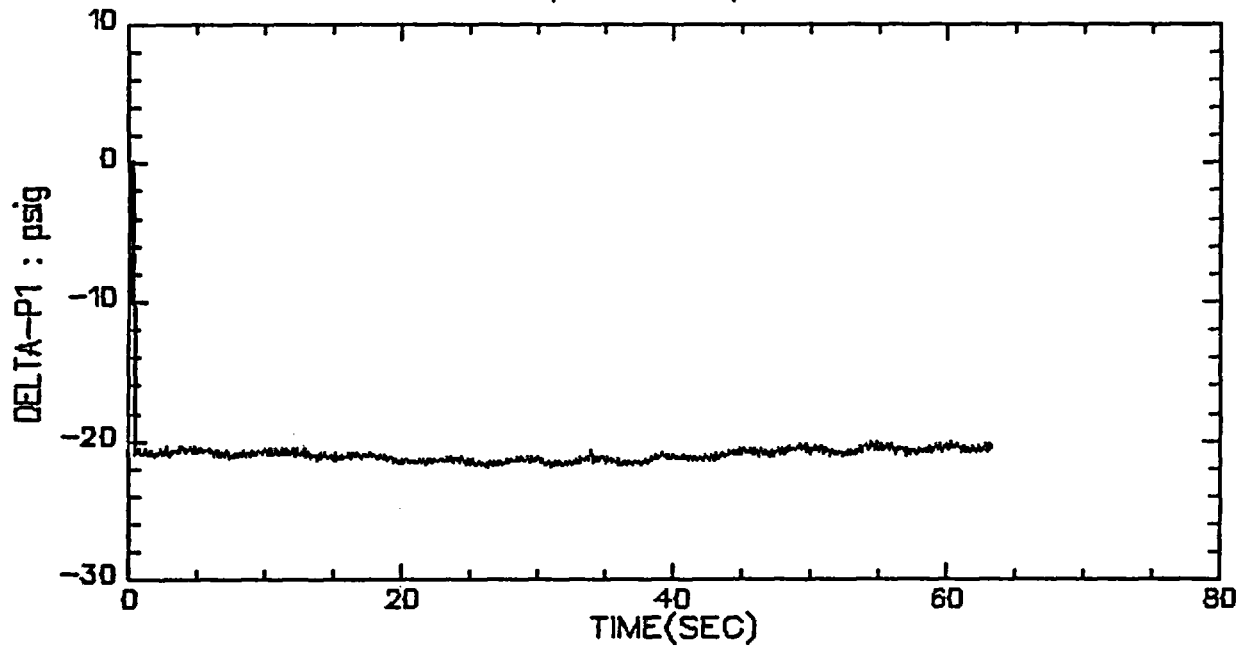

VALVE A, TEST 7 STEP 3&4

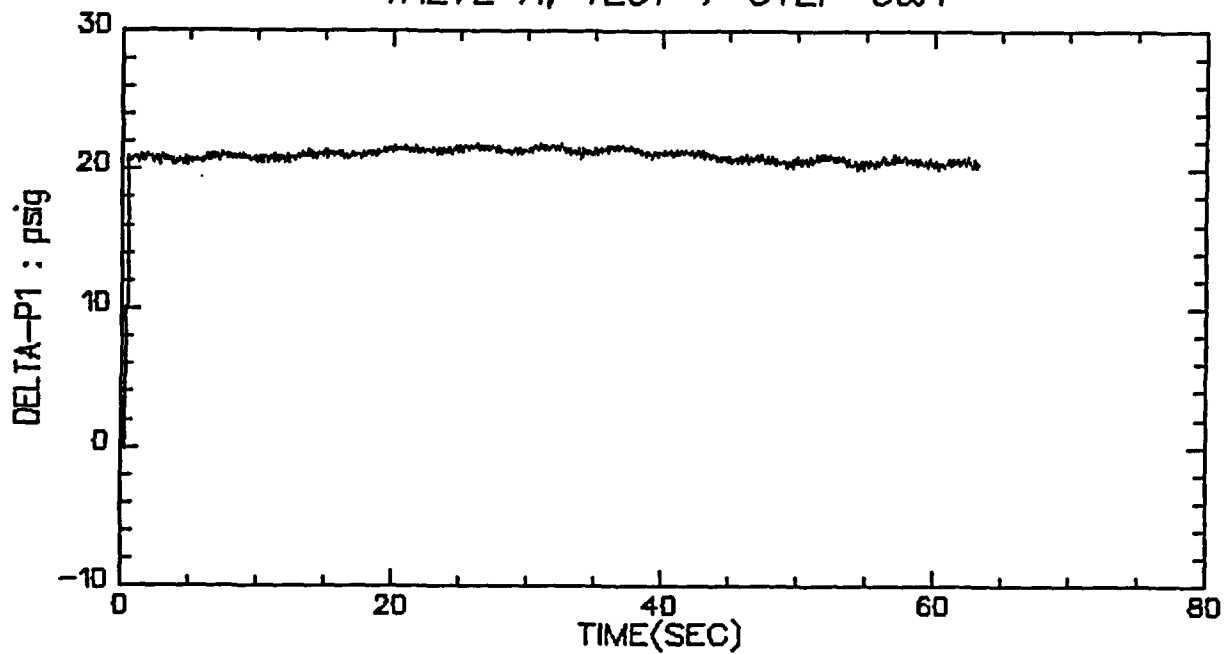

VALVE A, TEST 7, STEP 3&4

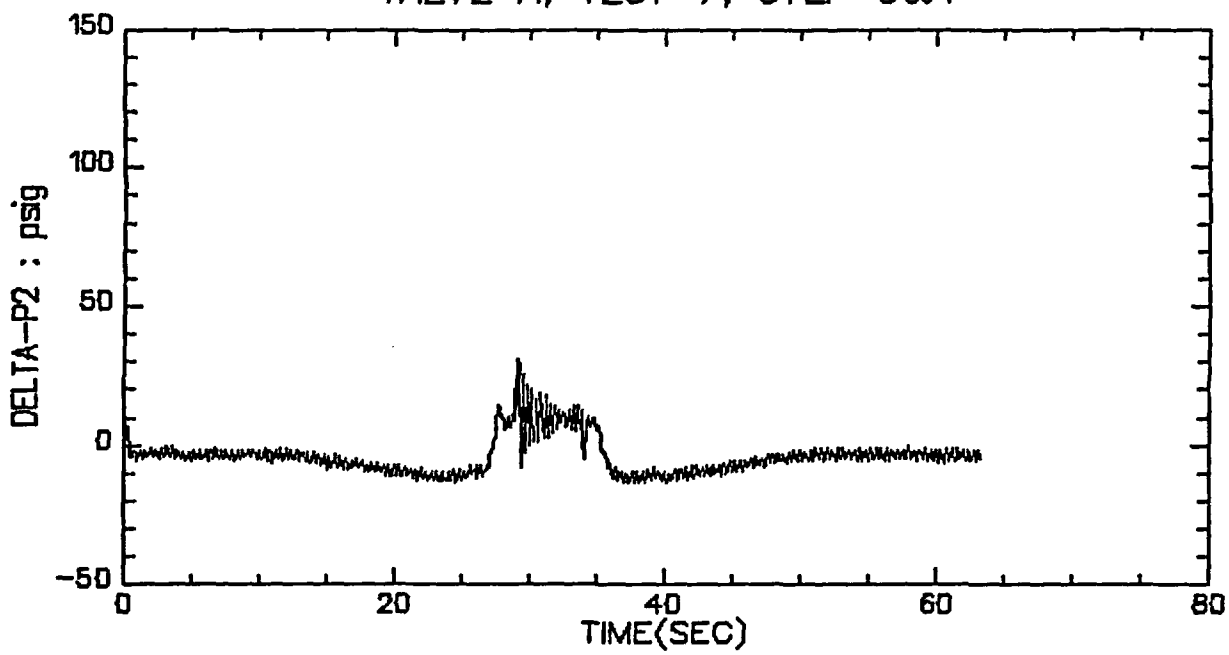

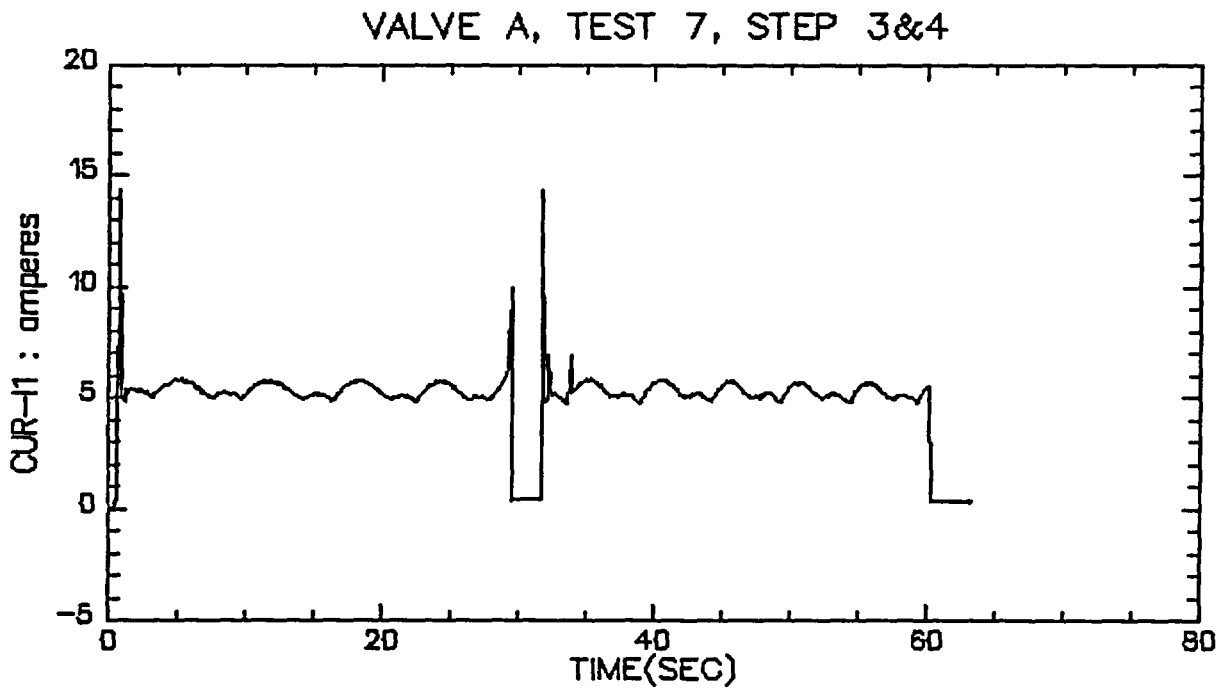
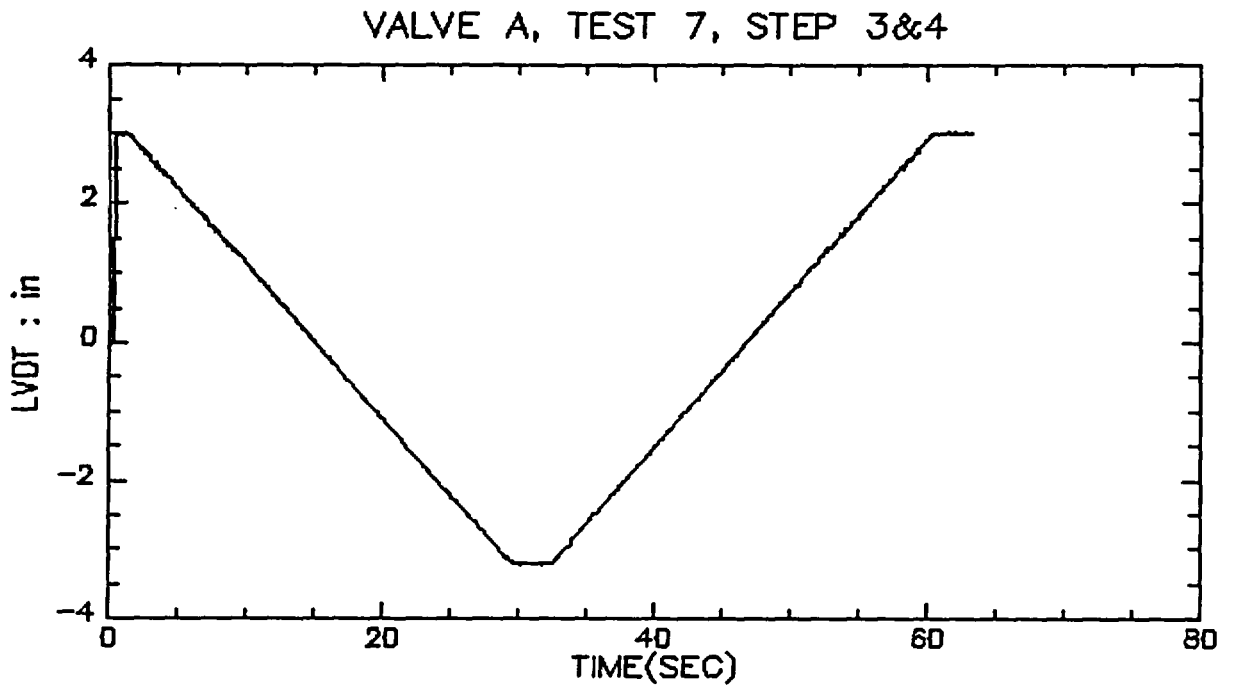

VALVE A, TEST 7, STEP 3&4

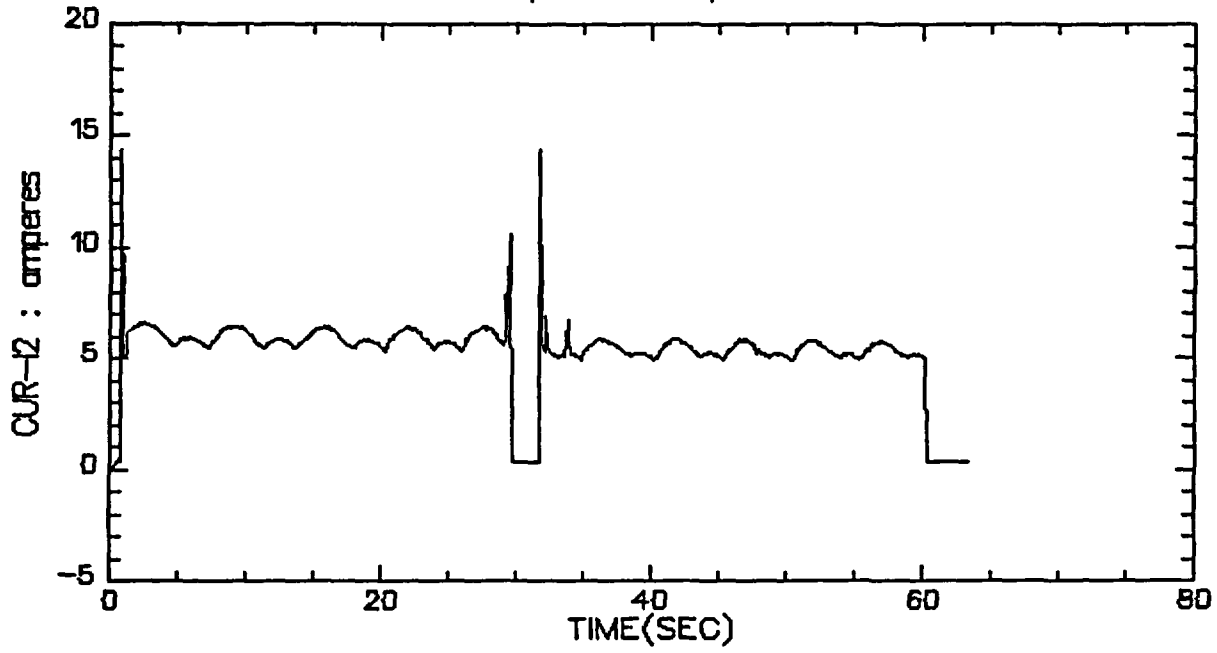

VALVE A, TEST 7, STEP 3&4

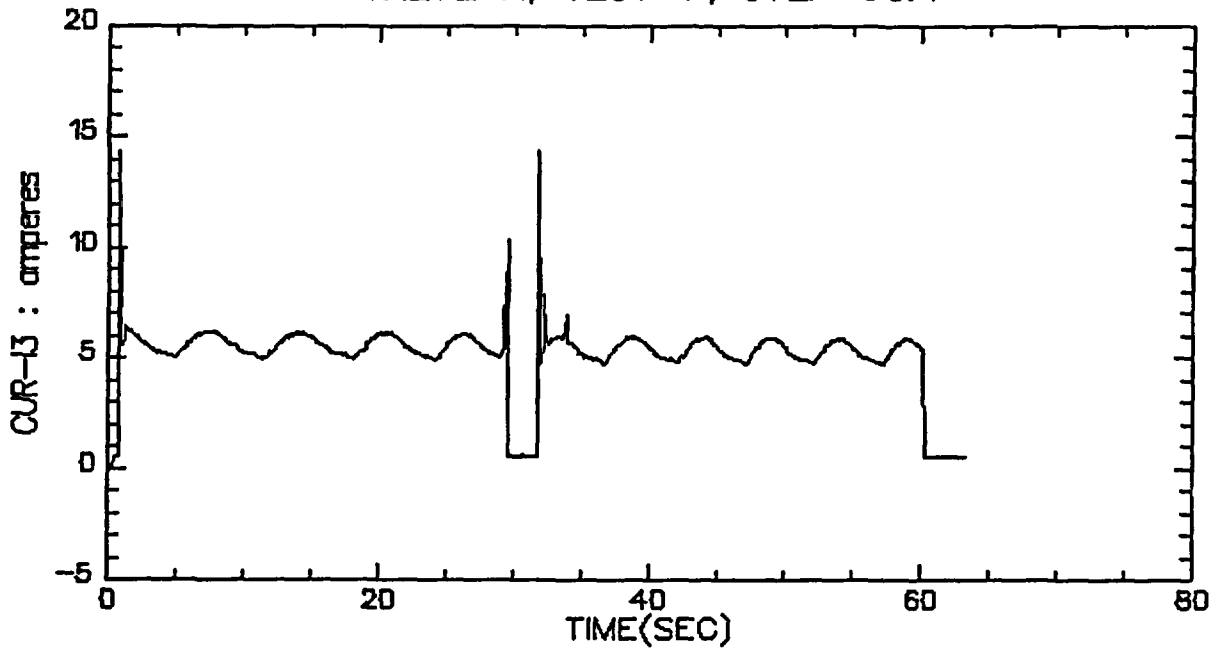

VALVE A, TEST 7, STEP 3&4

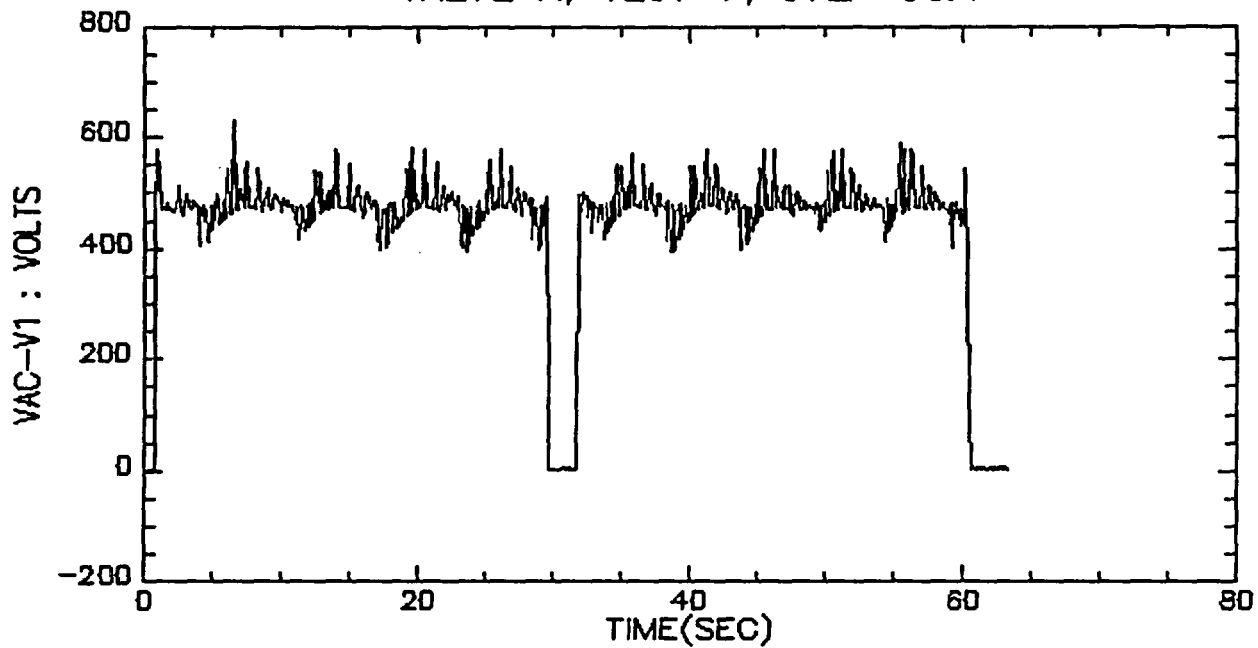

VALVE A, TEST 7, STEP 3&4

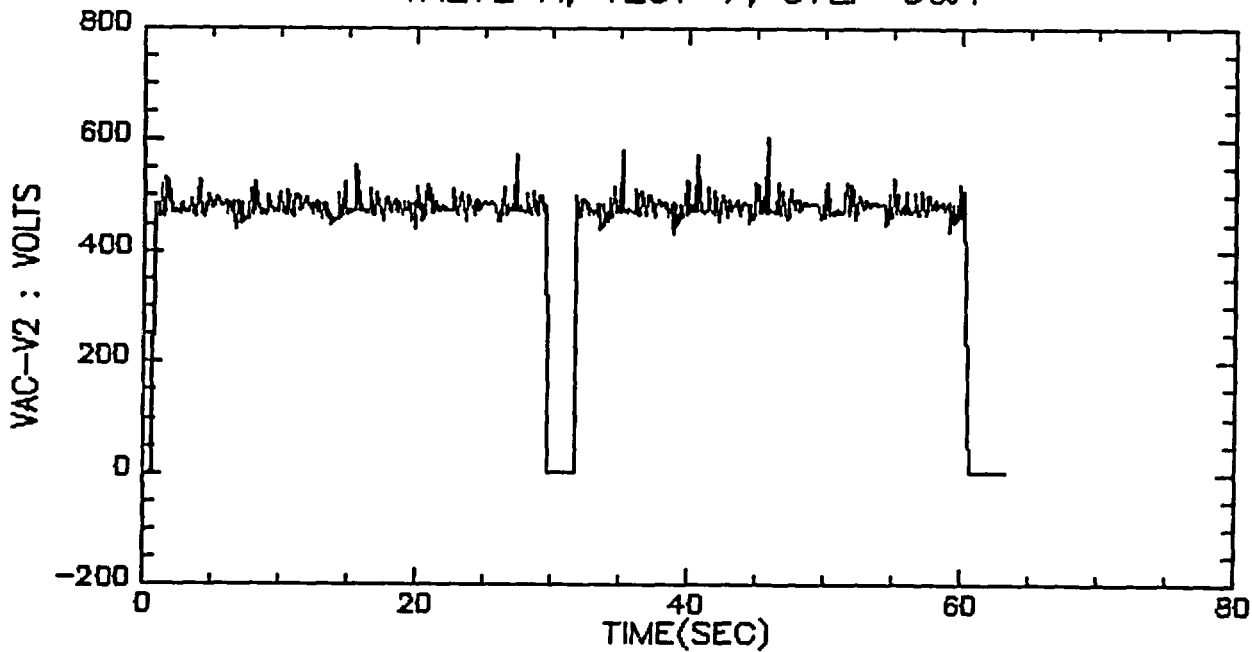

VALVE A, TEST 7, STEP 3&4

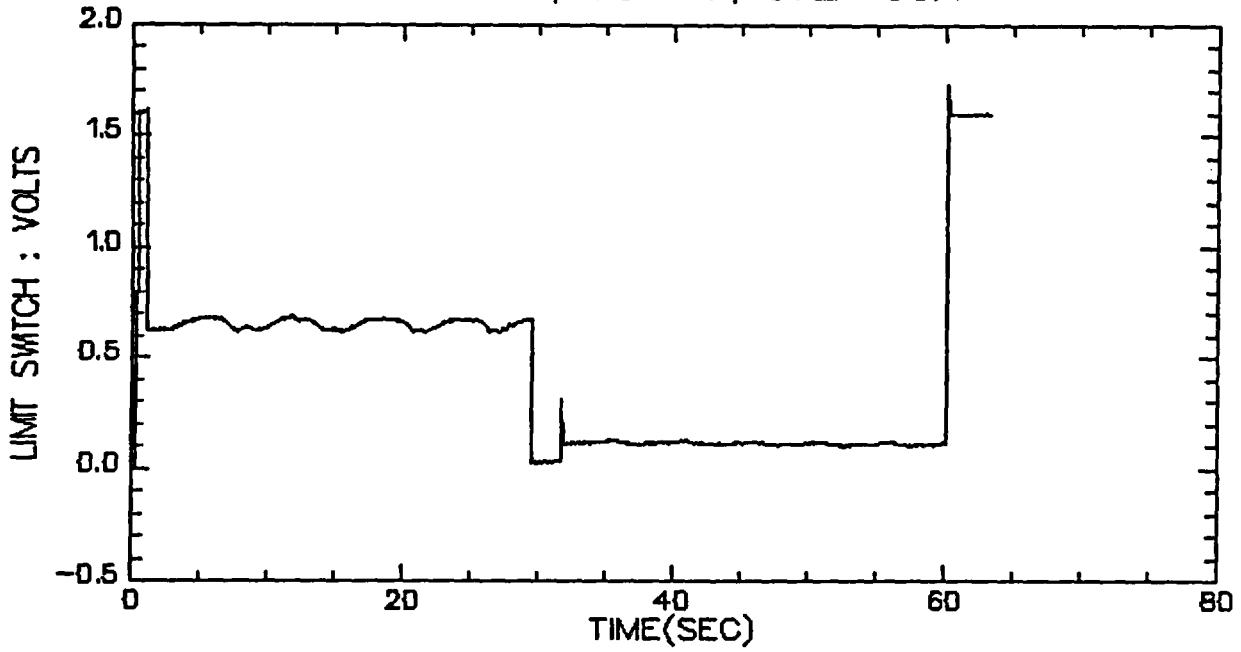

VALVE A, TEST 7, STEP 3&4

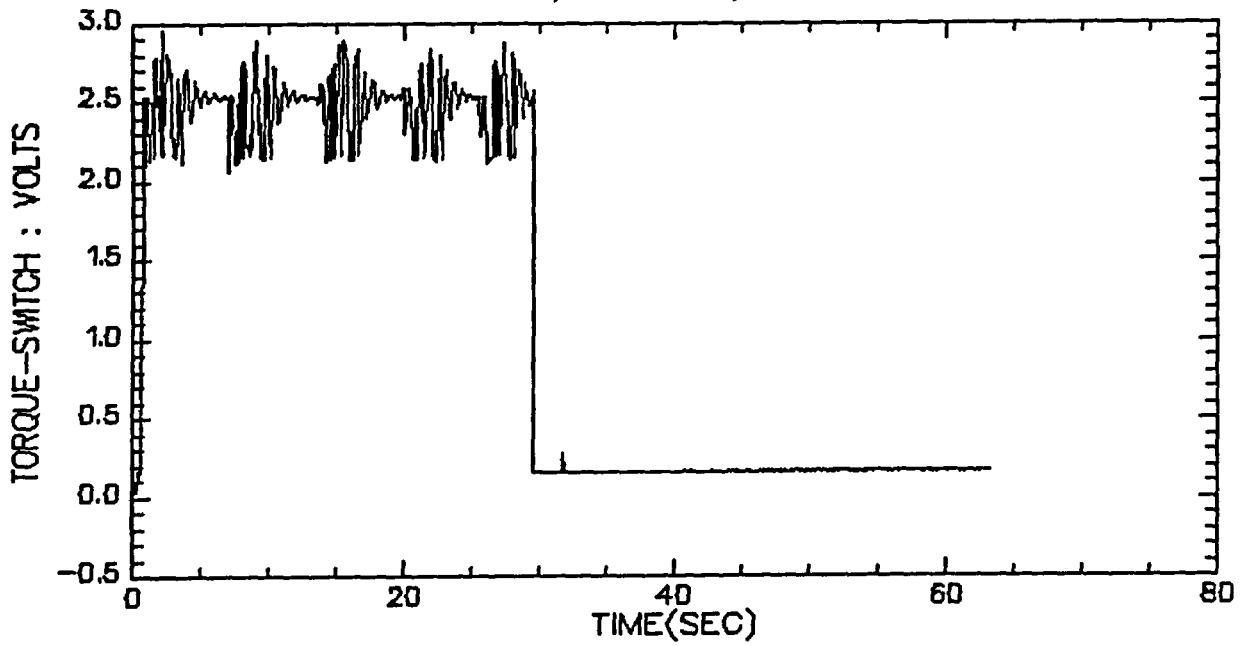

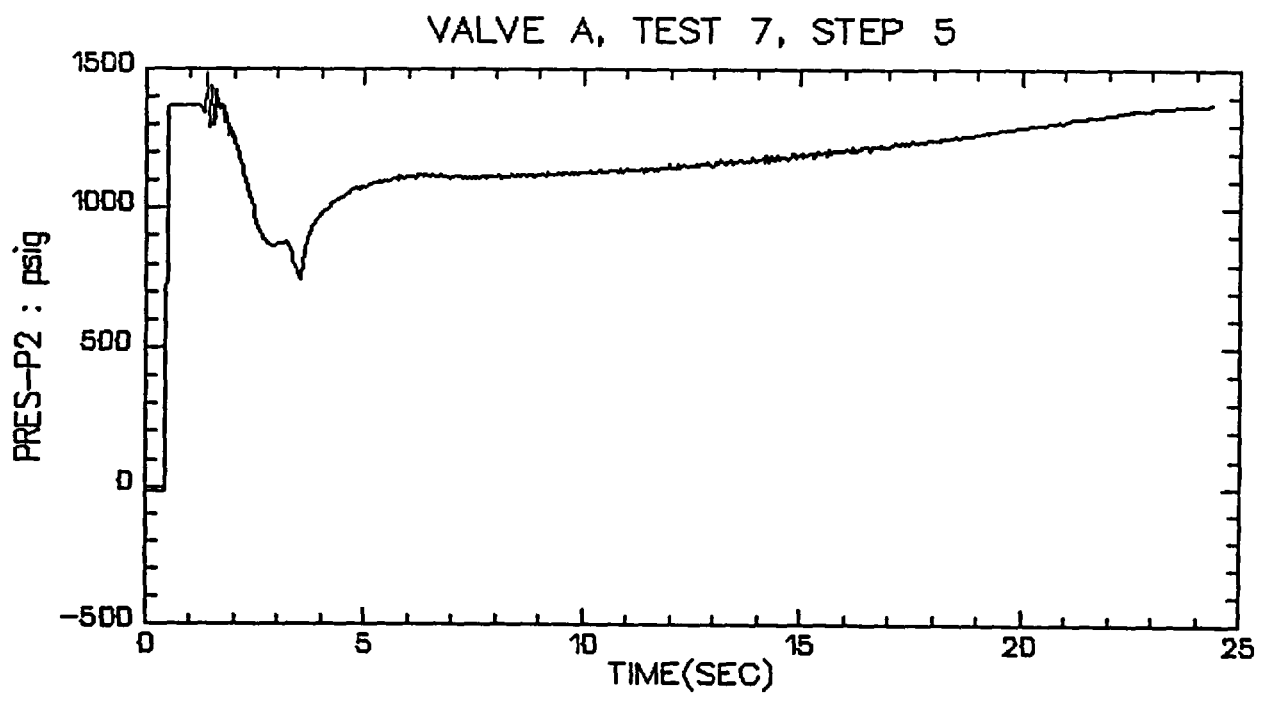
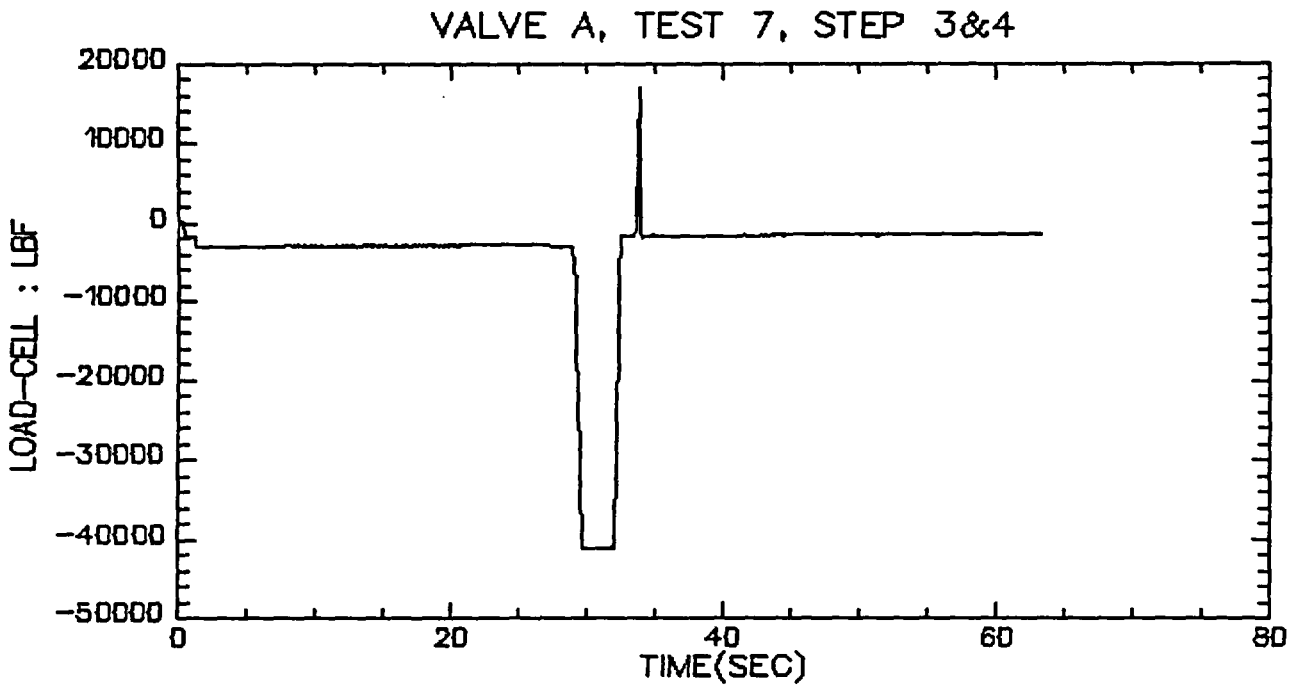

VALVE A, TEST 7, STEP 5

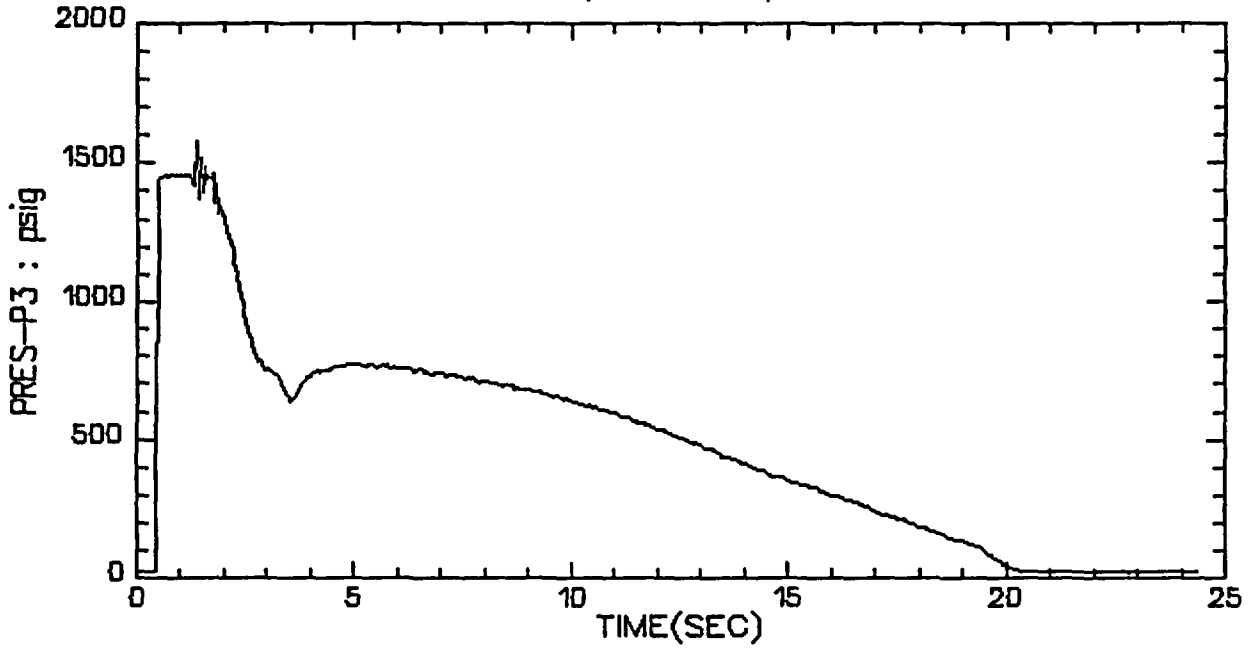

VALVE A, TEST 7, STEP 5

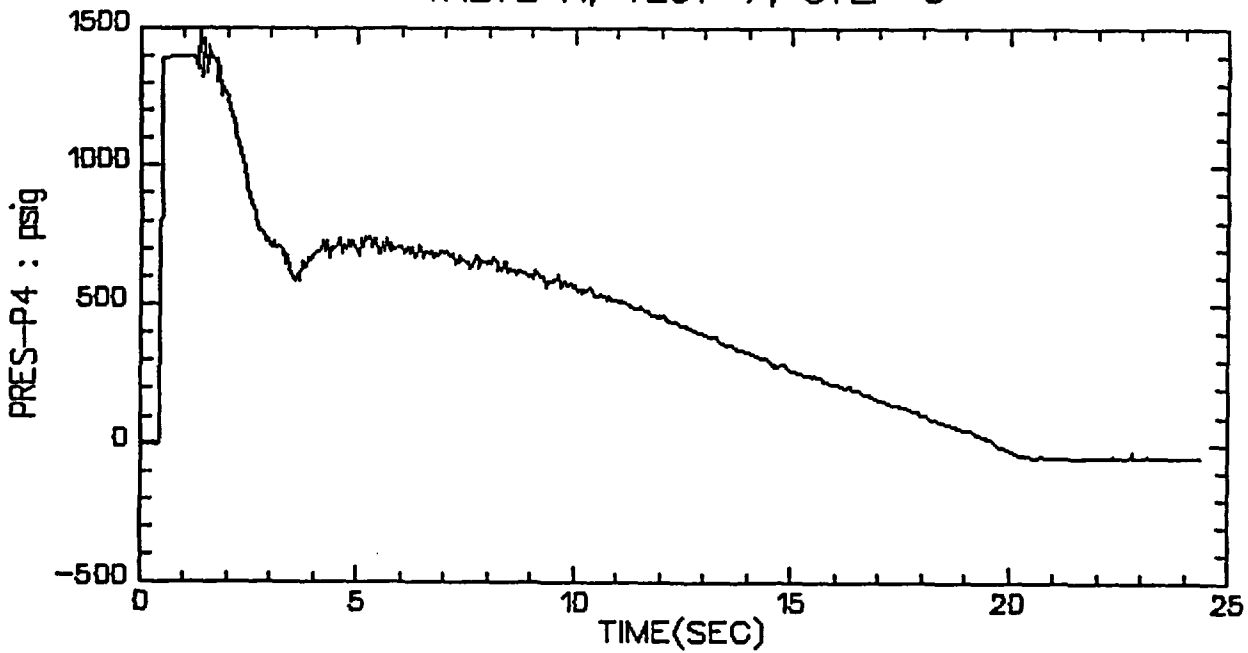

VALVE A, TEST 7, STEP 5

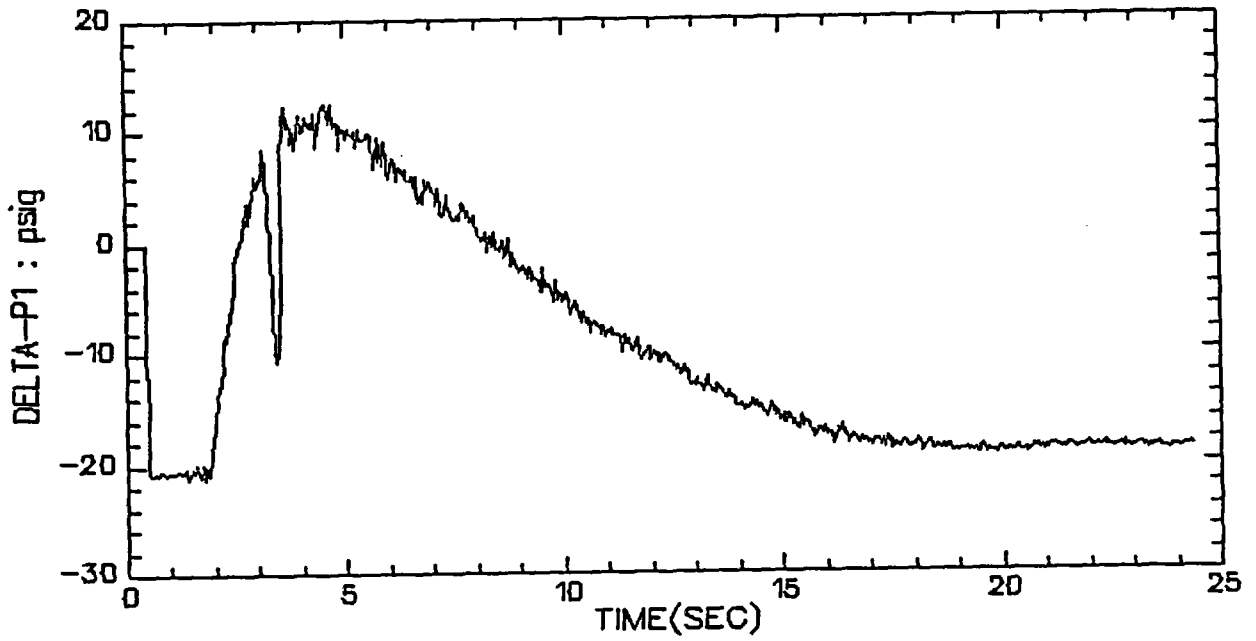

VALVE A, TEST 7, STEP 5

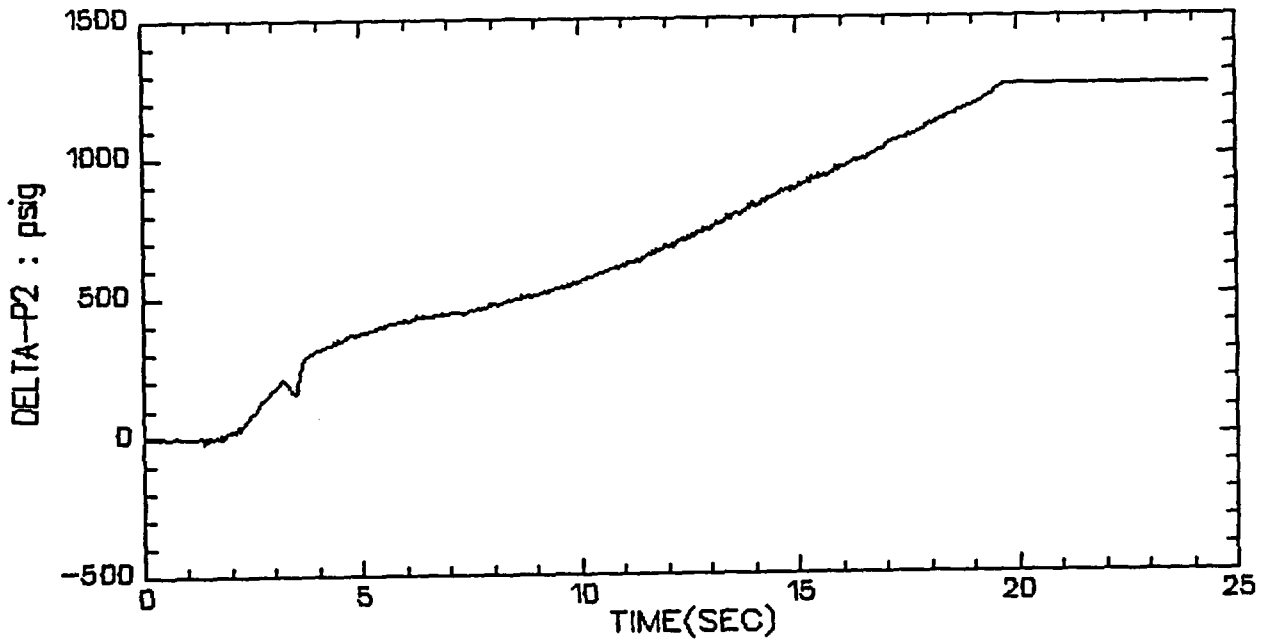

VALVE A, TEST 7, STEP 5

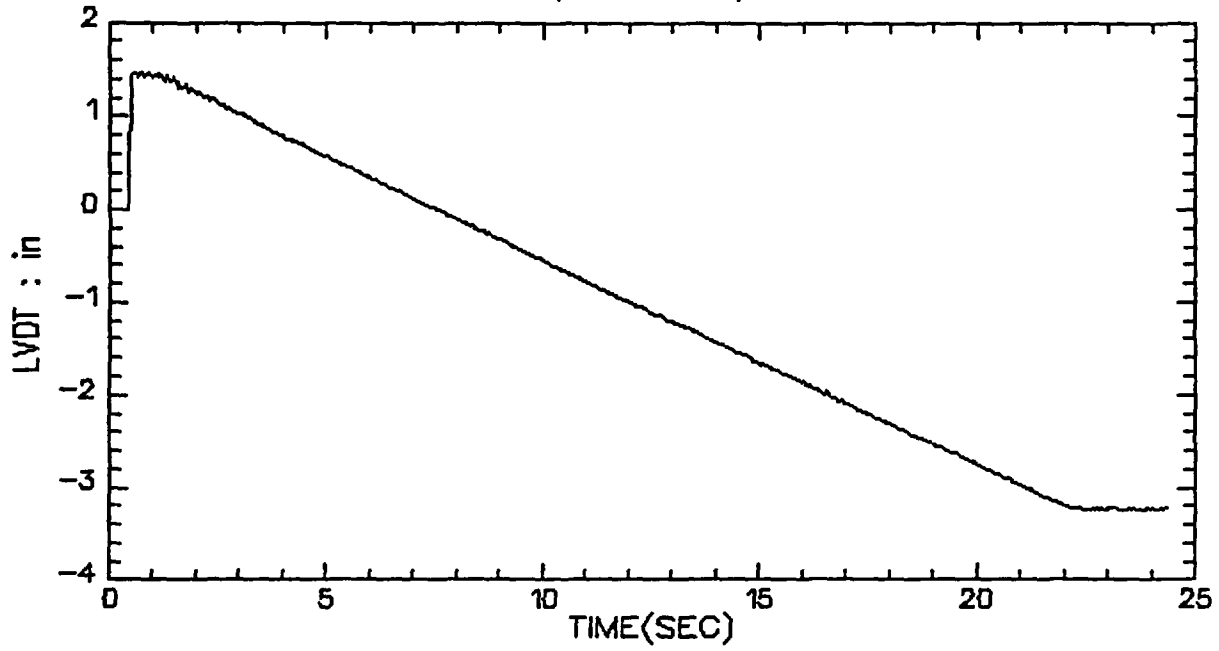

VALVE A, TEST 7, STEP 5

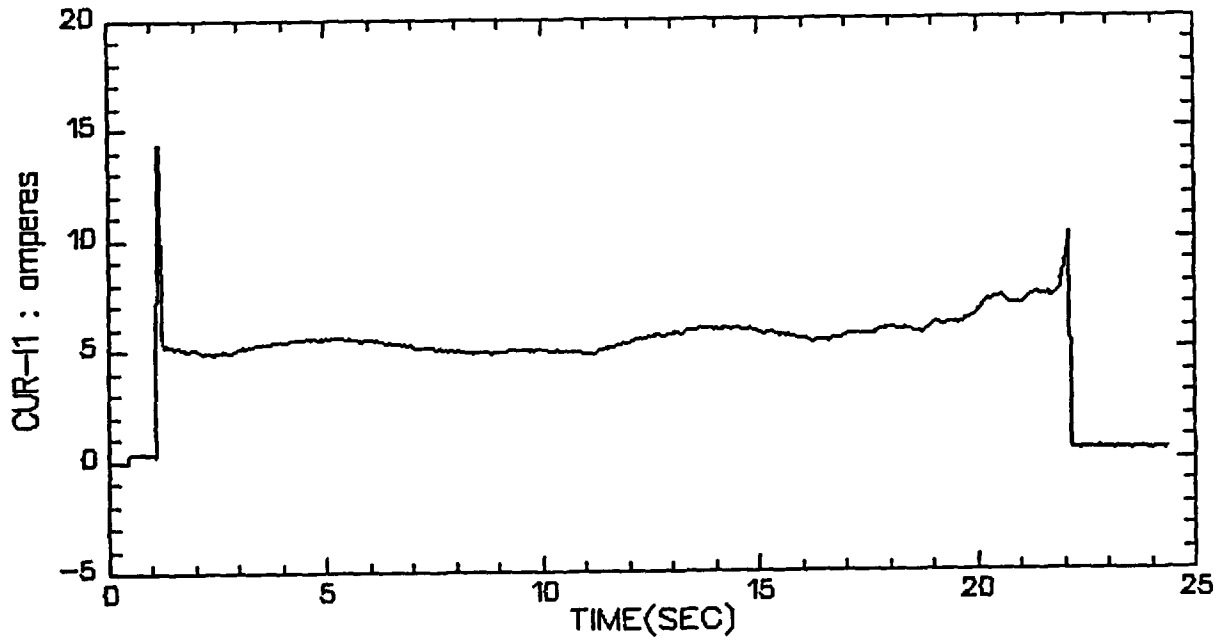

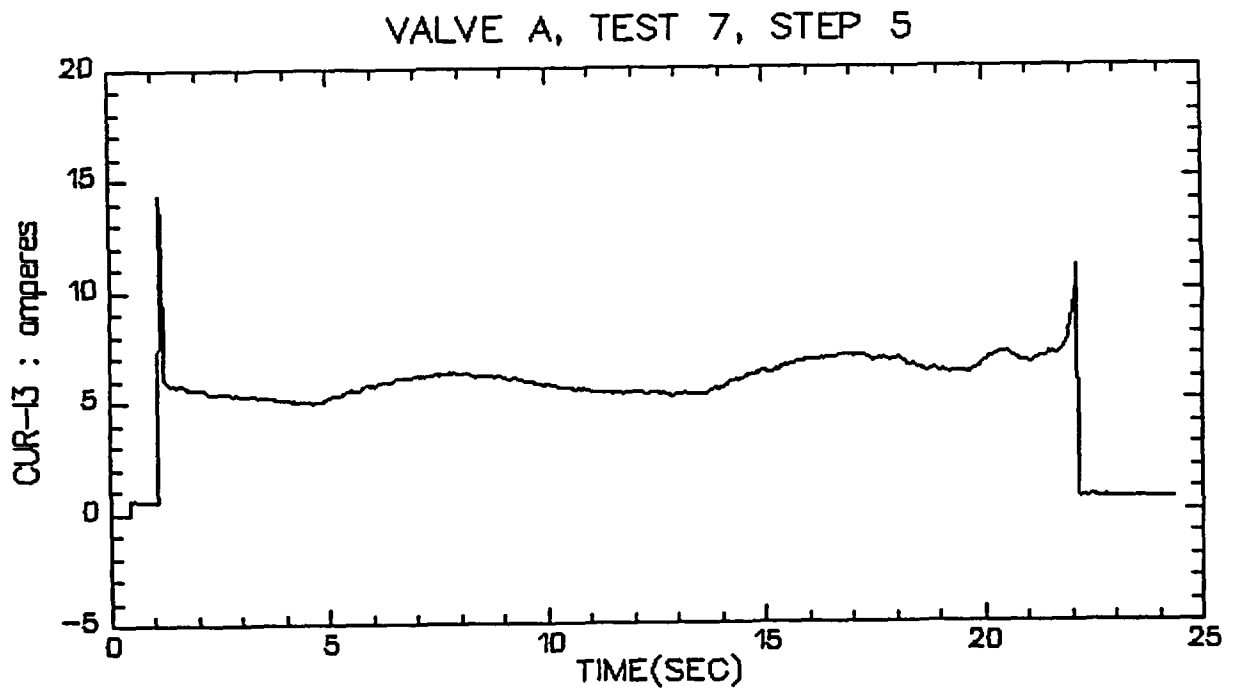
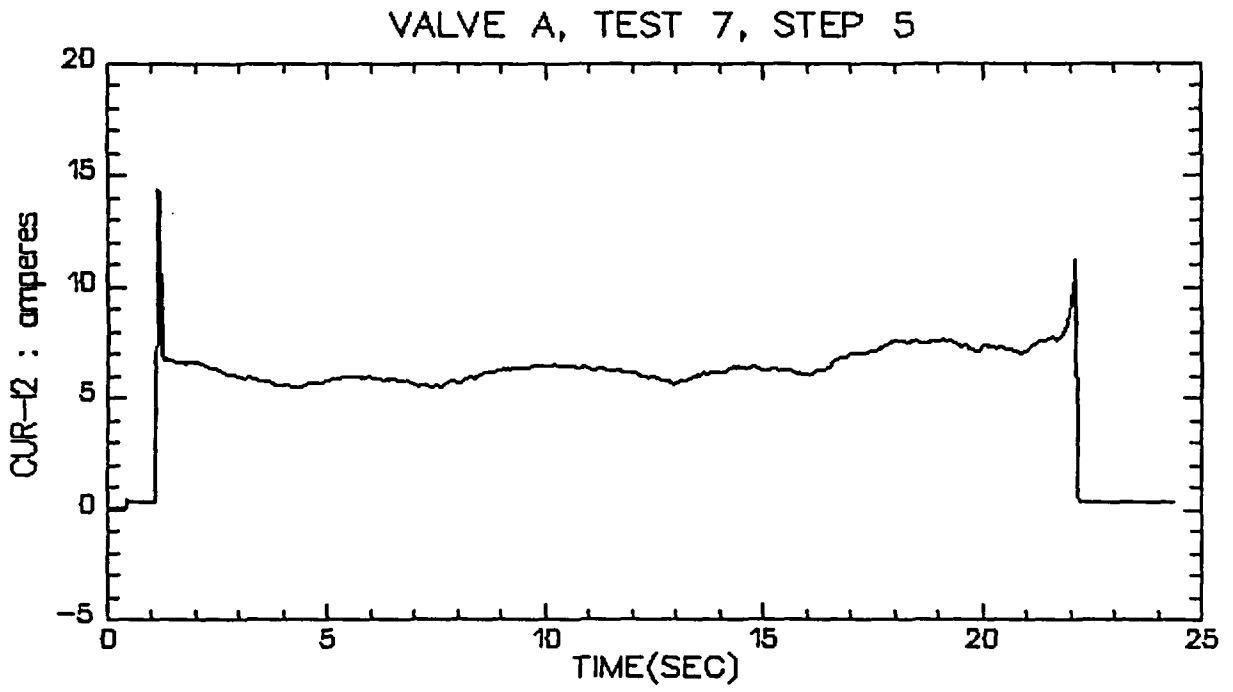

VALVE A, TEST 7, STEP 5

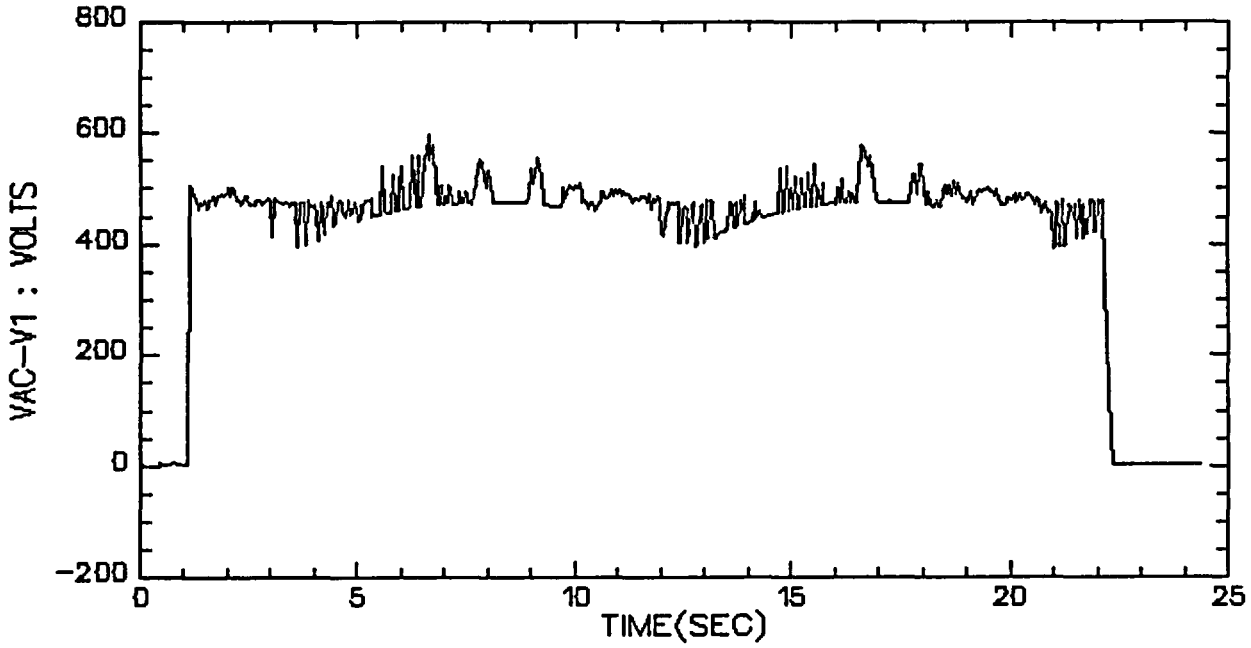

VALVE A, TEST 7, STEP 5

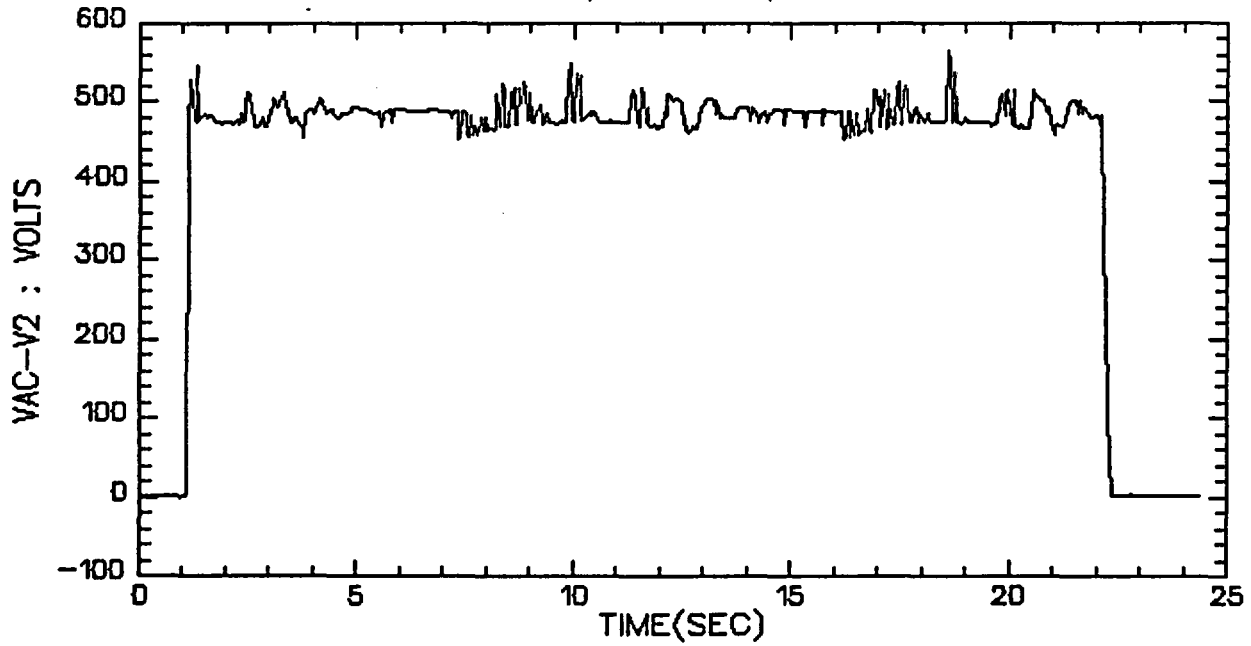

VALVE A, TEST 7, STEP 5

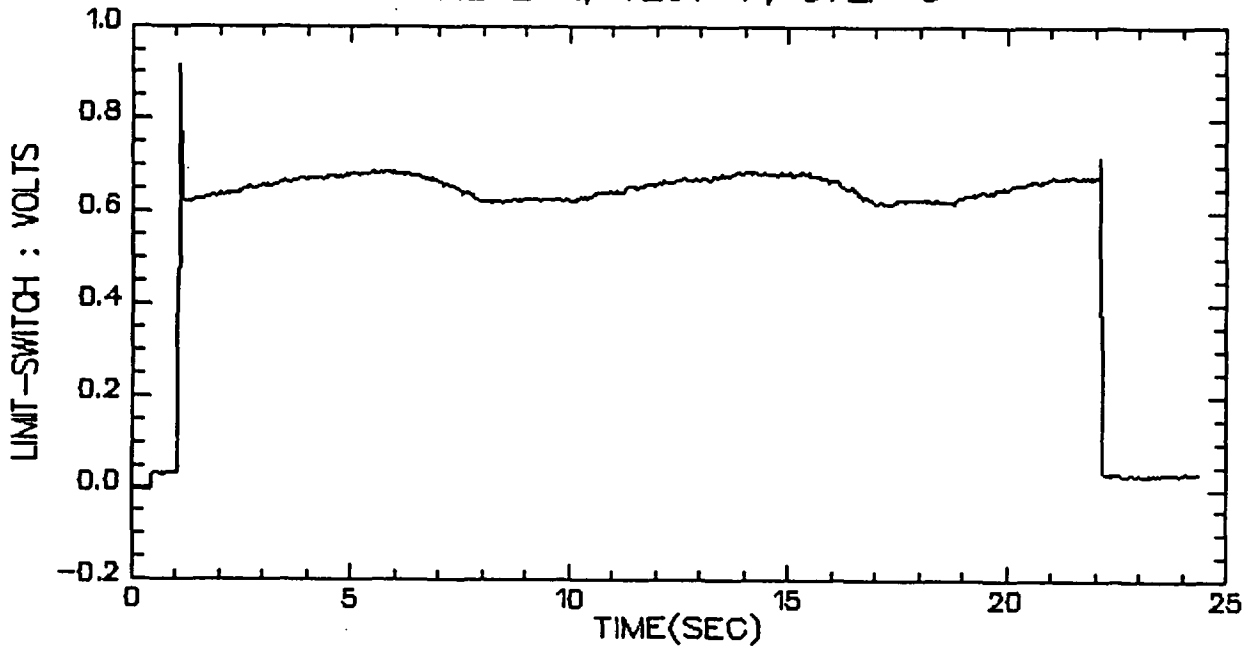

VALVE A, TEST 7, STEP 5

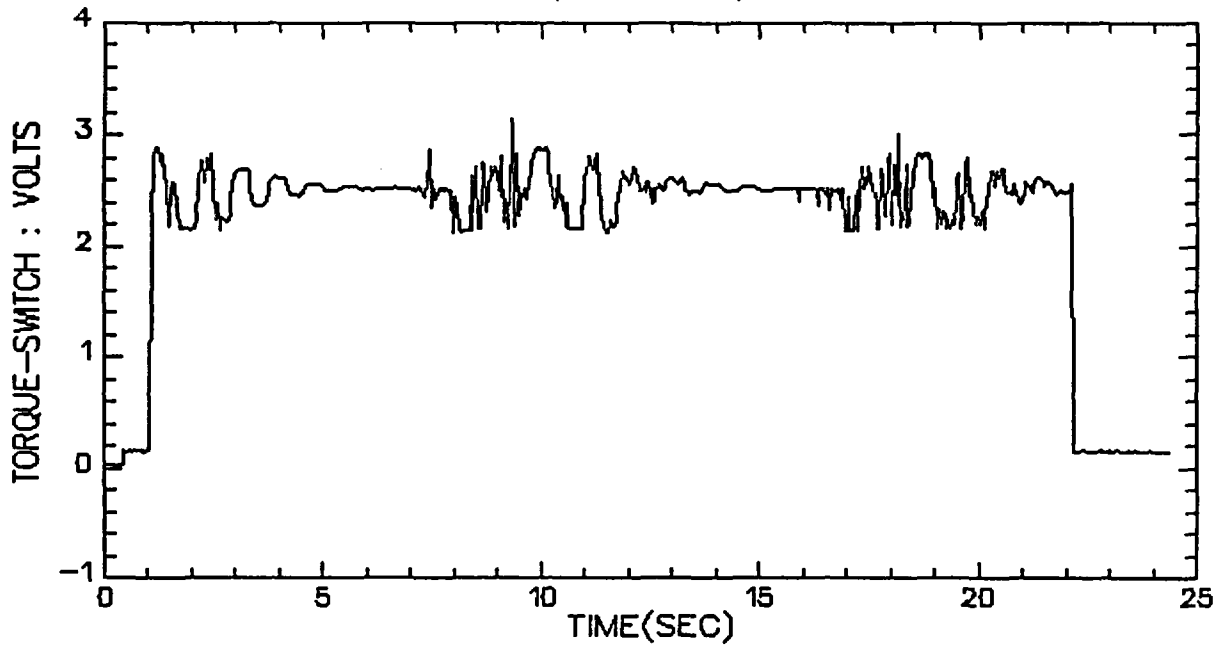

VALVE A, TEST 7, STEP 5

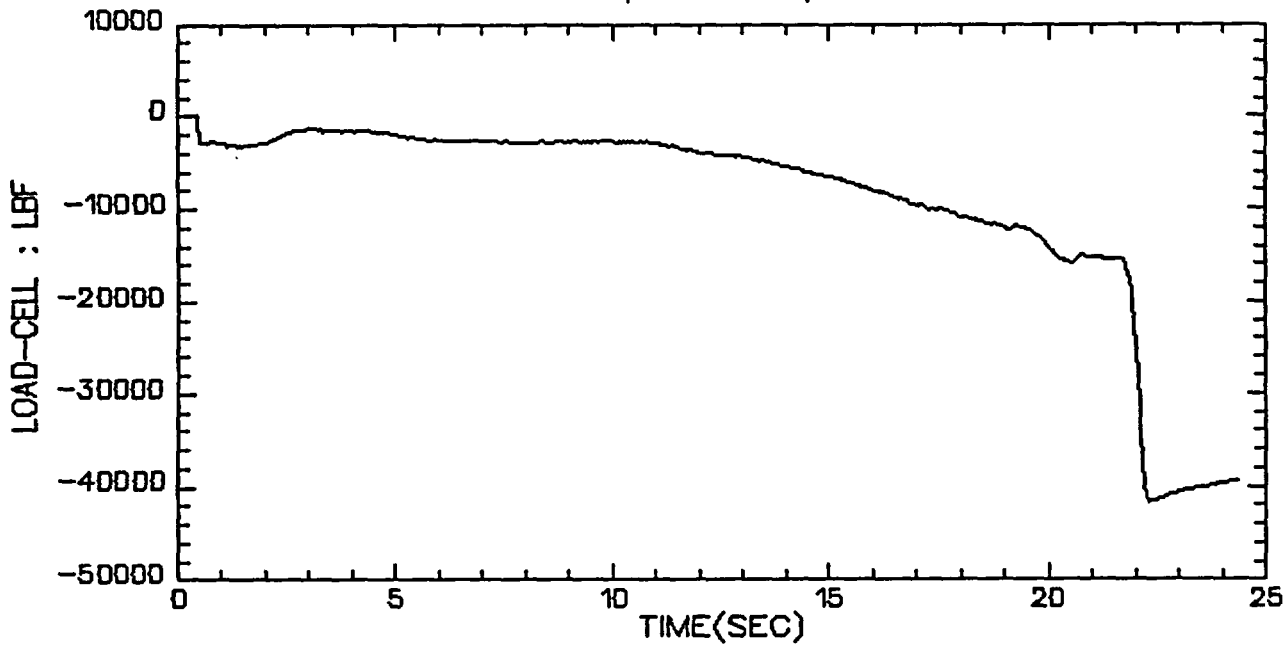

VALVE A, TEST 7, STEP 6&7

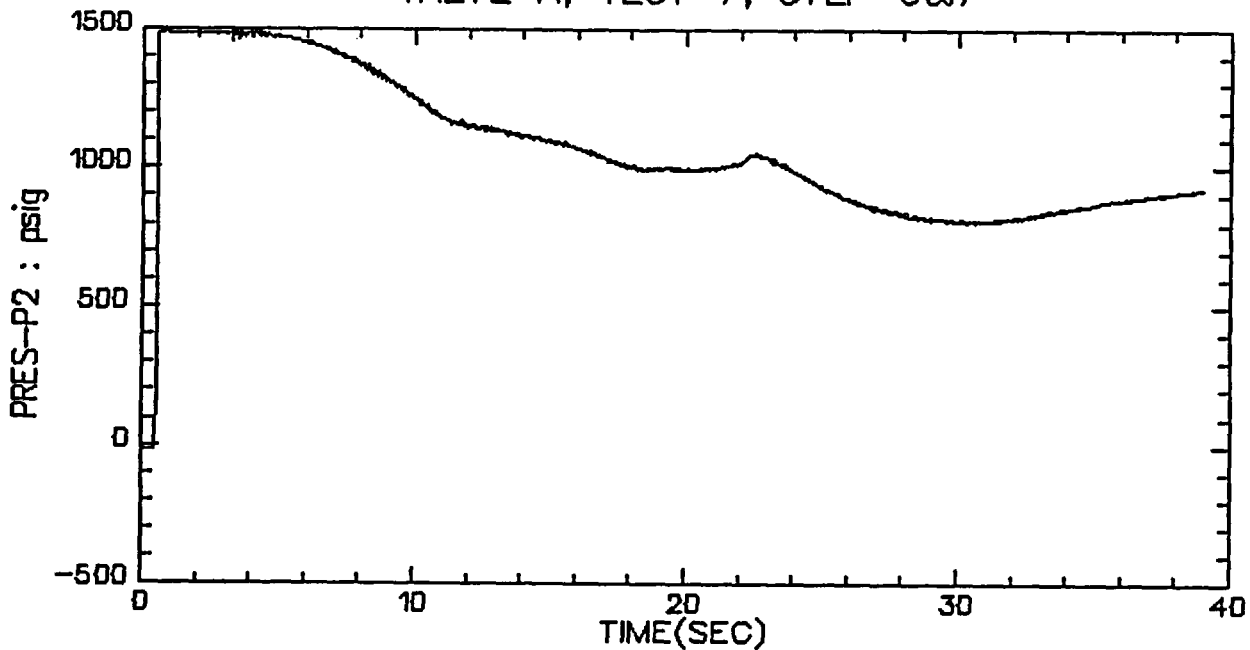

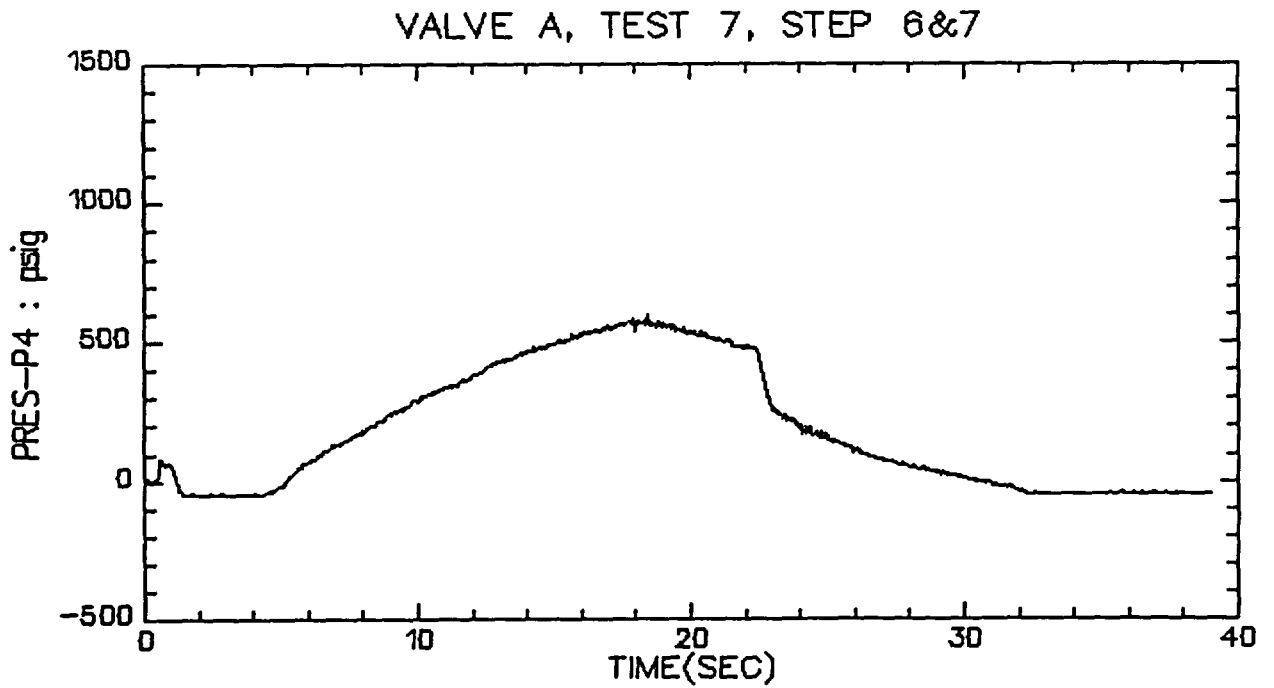
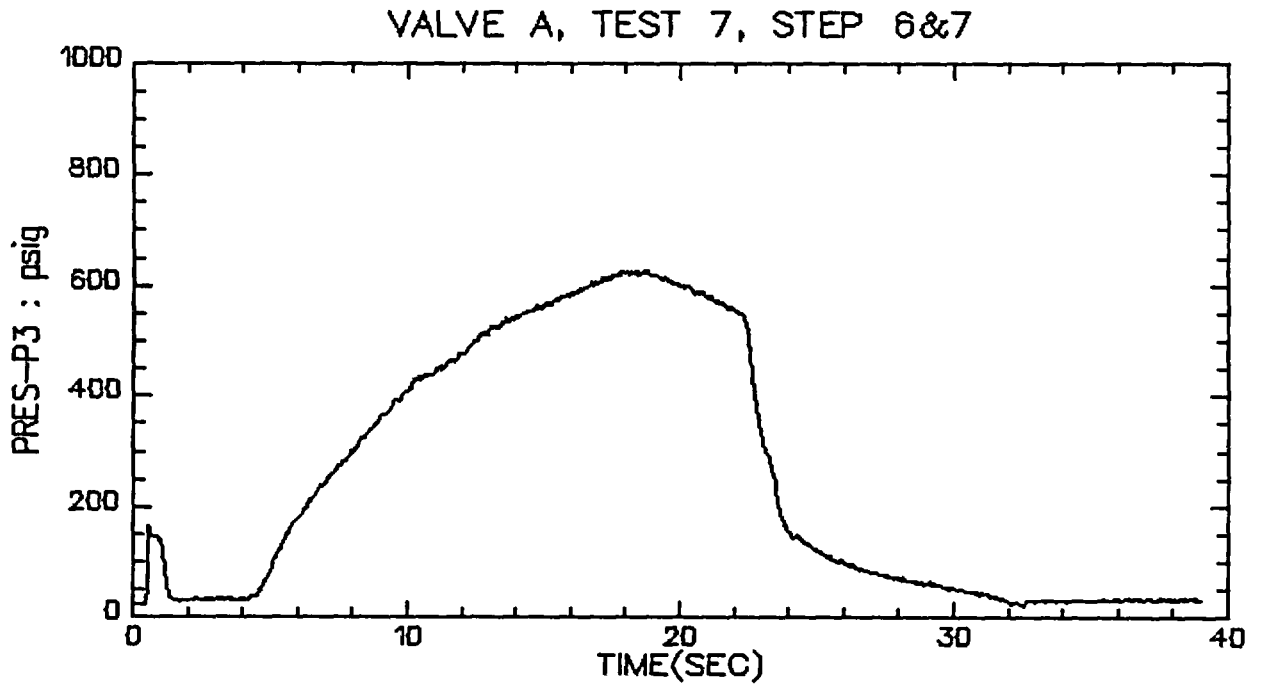

VALVE A, TEST 7, STEP 6&7

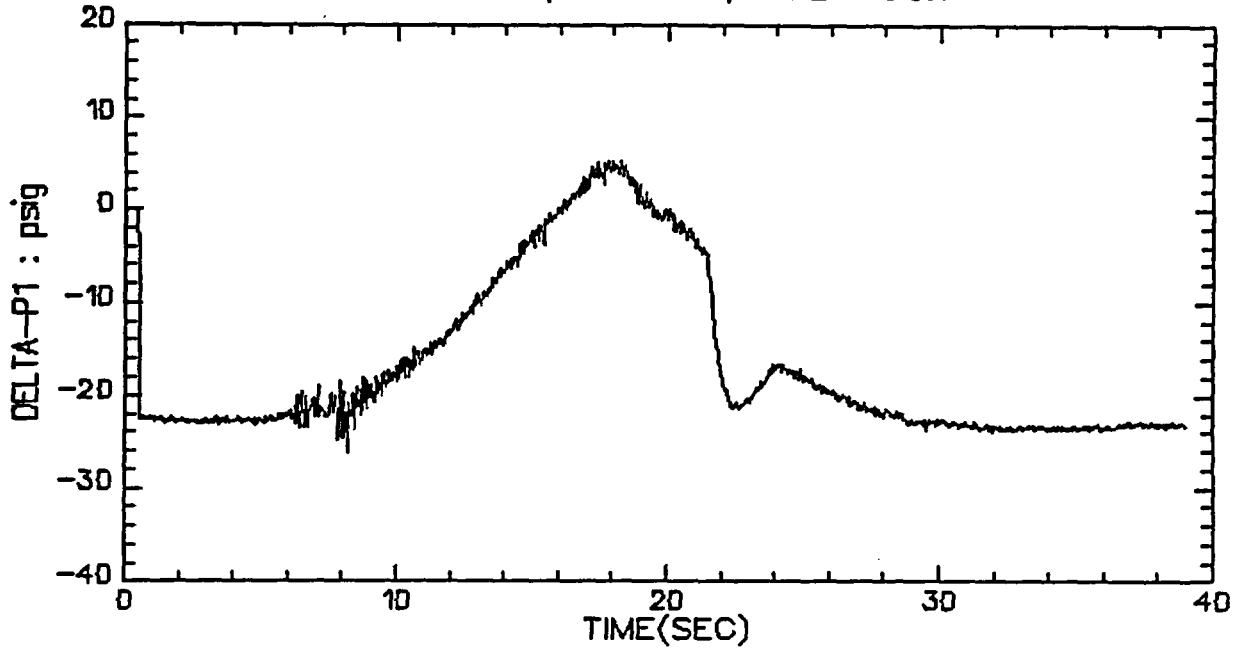

VALVE A, TEST 7, STEP 6&7

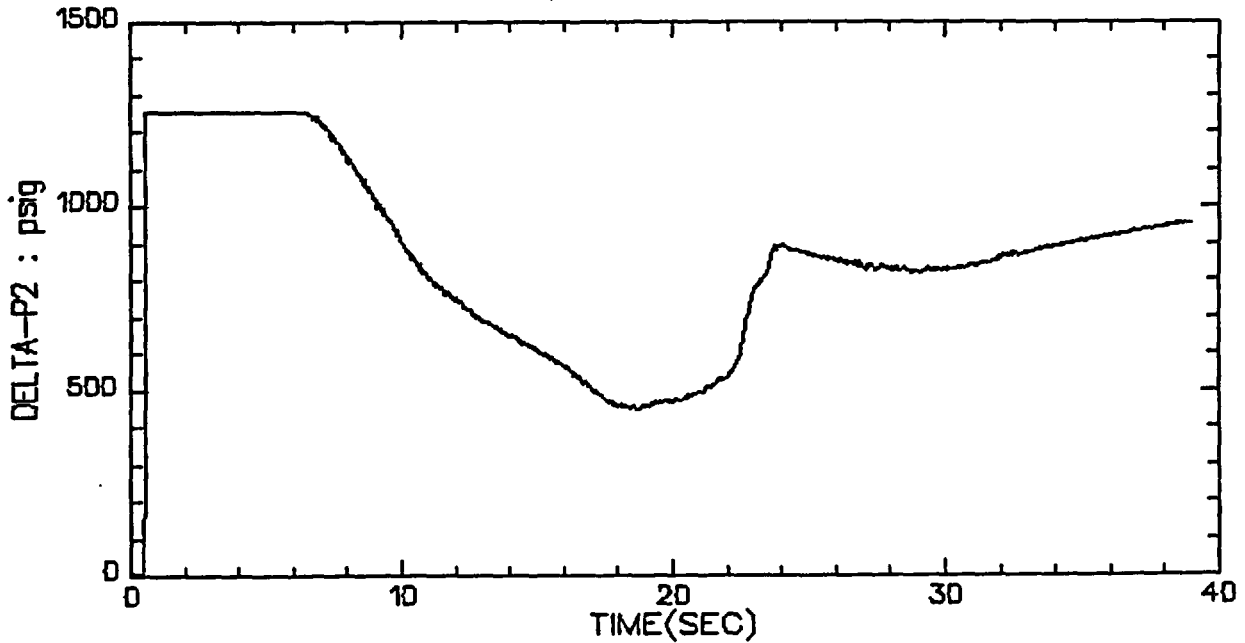

VALVE A, TEST 7, STEP 6&7

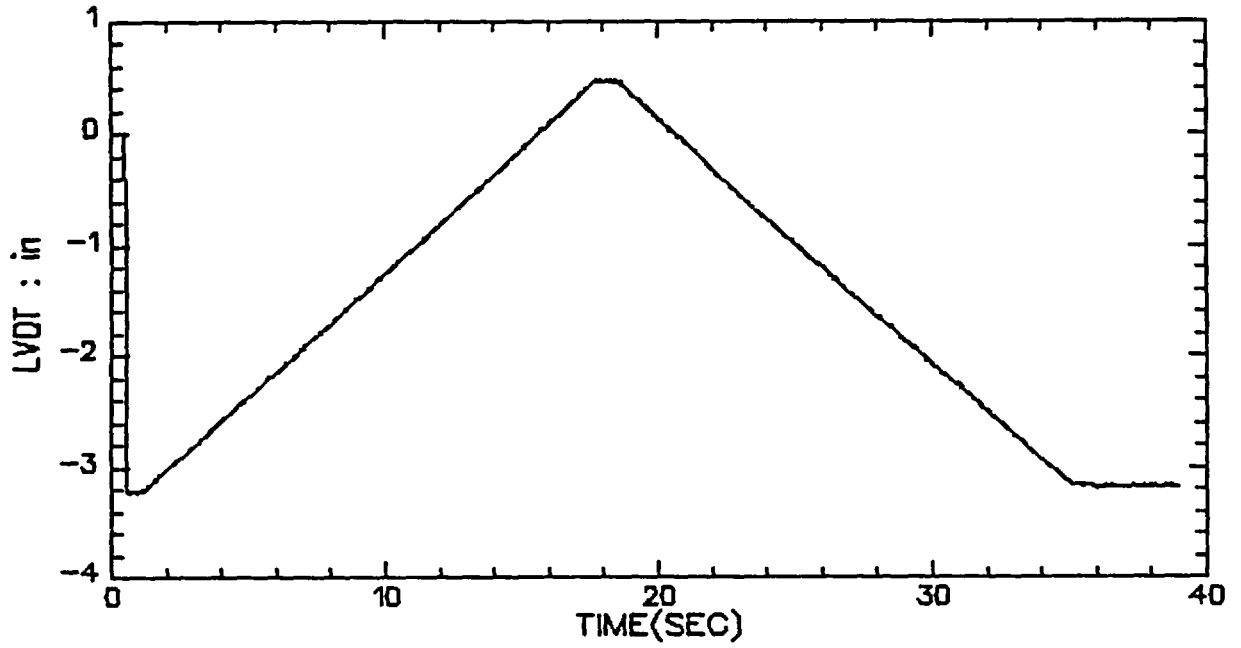

VALVE A, TEST 7, STEP 6&7

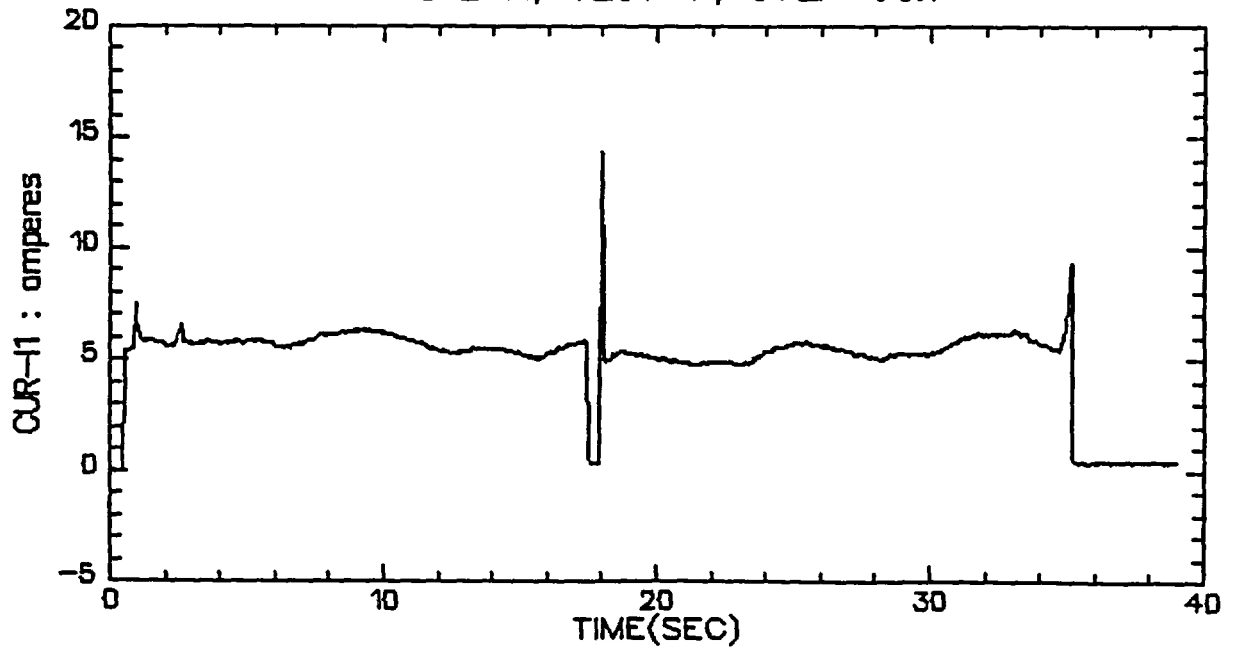

VALVE A, TEST 7, STEP 6&7

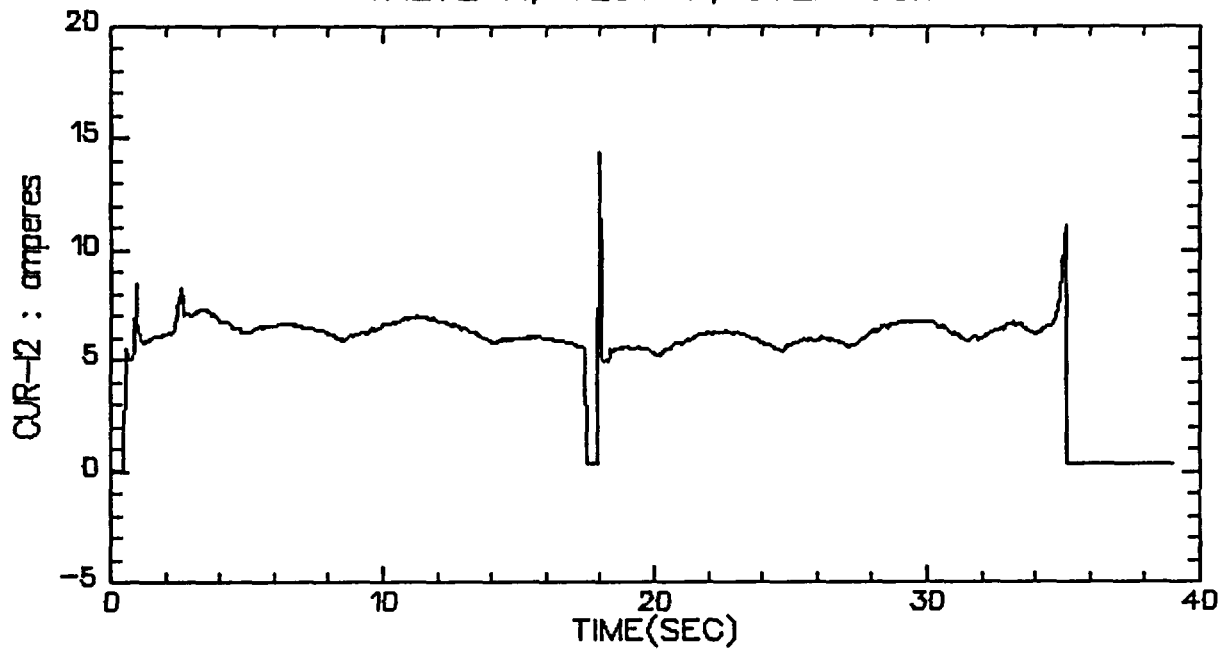

VALVE A, TEST 7, STEP 6&7

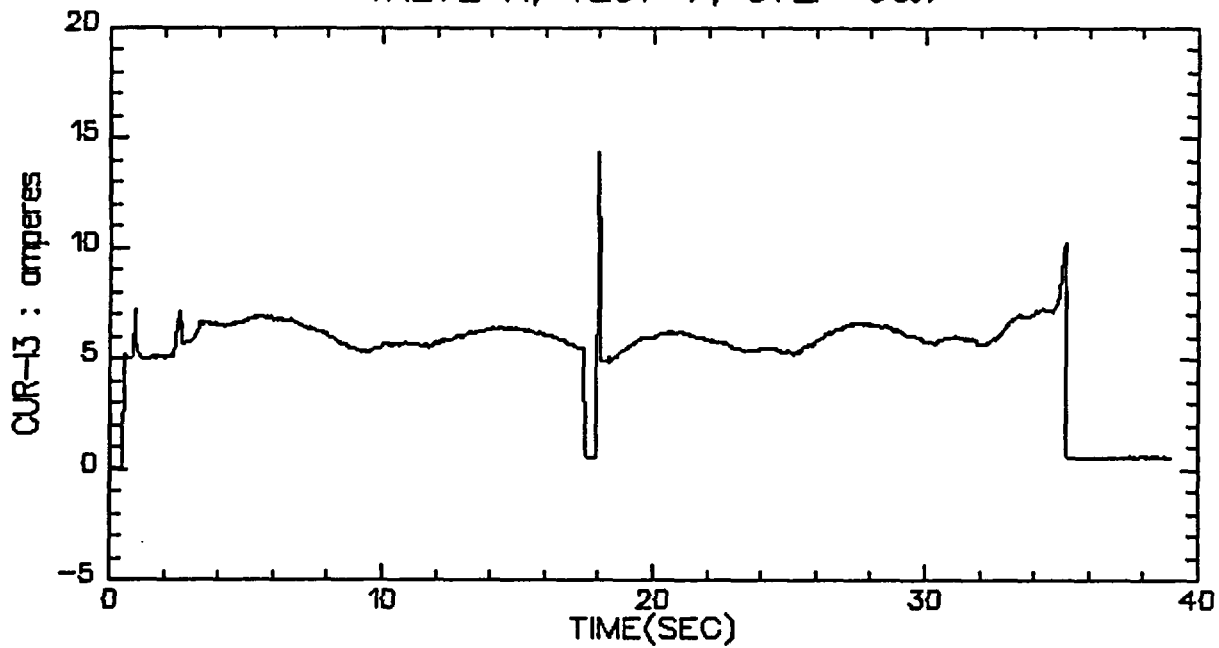

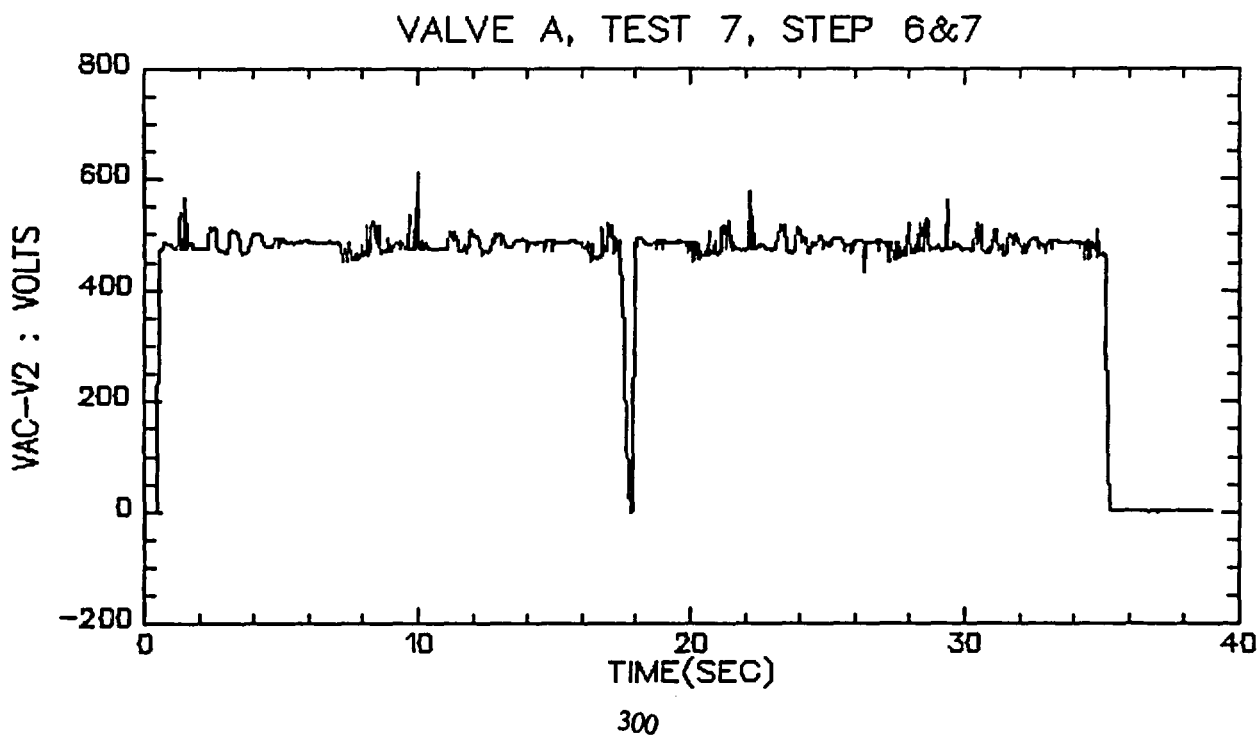
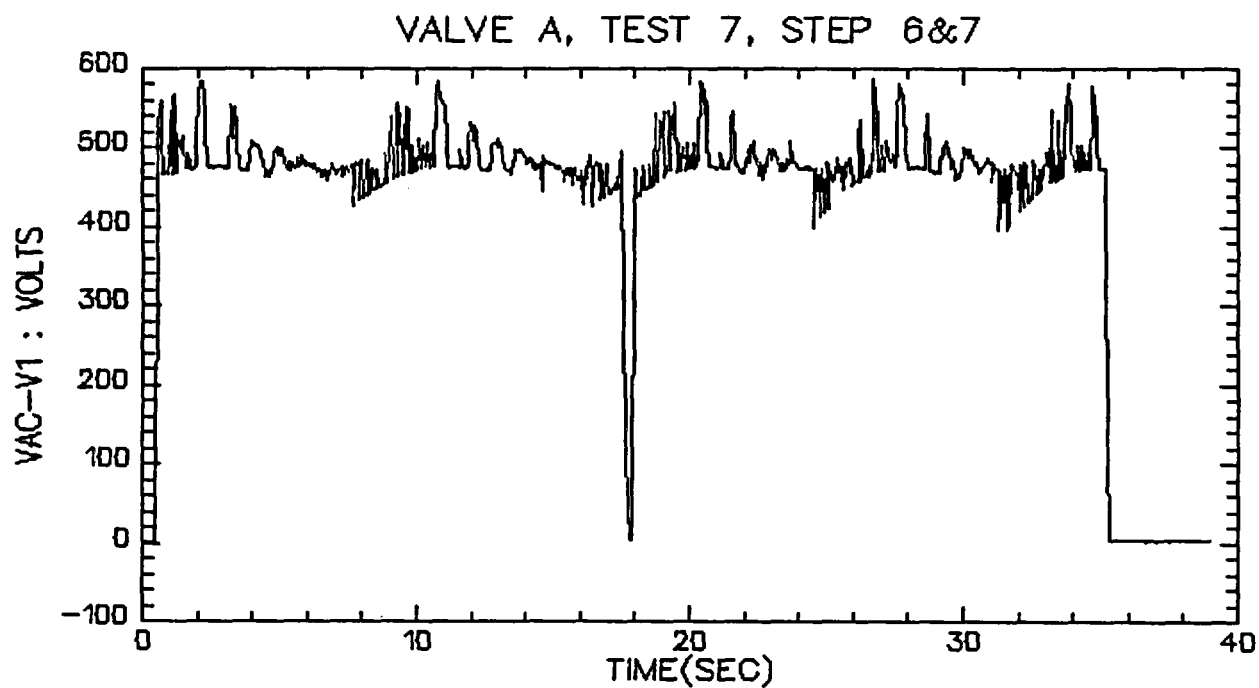

VALVE A, TEST 7, STEP 6&7

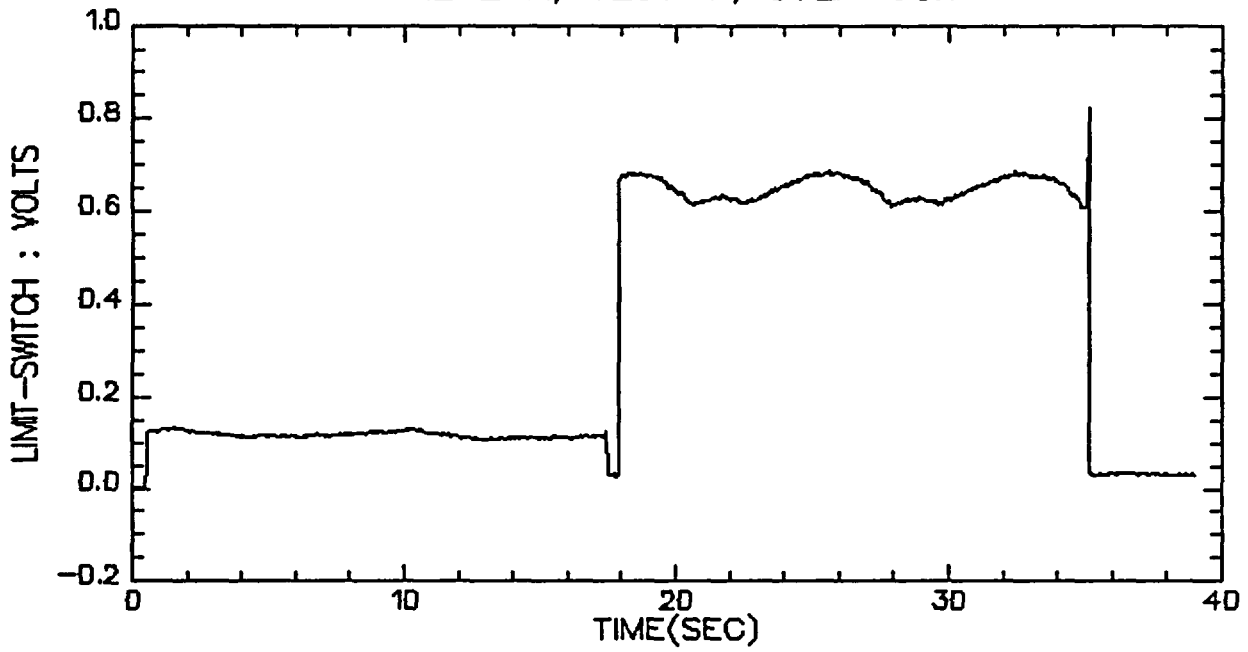

VALVE A, TEST 7, STEP 6&7

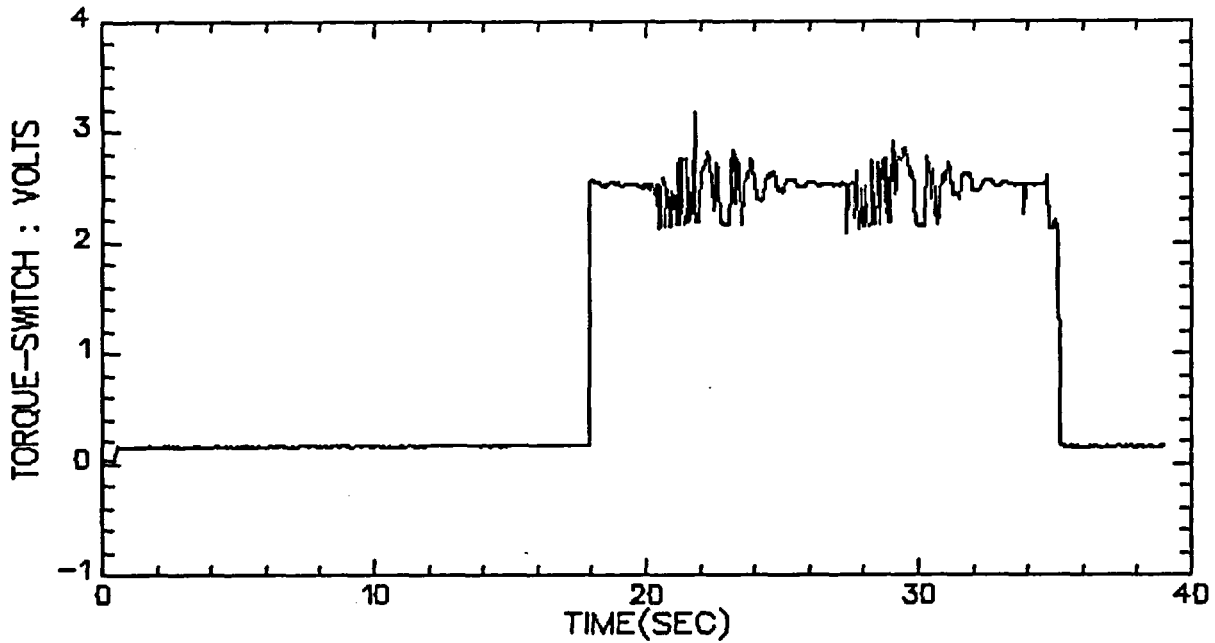

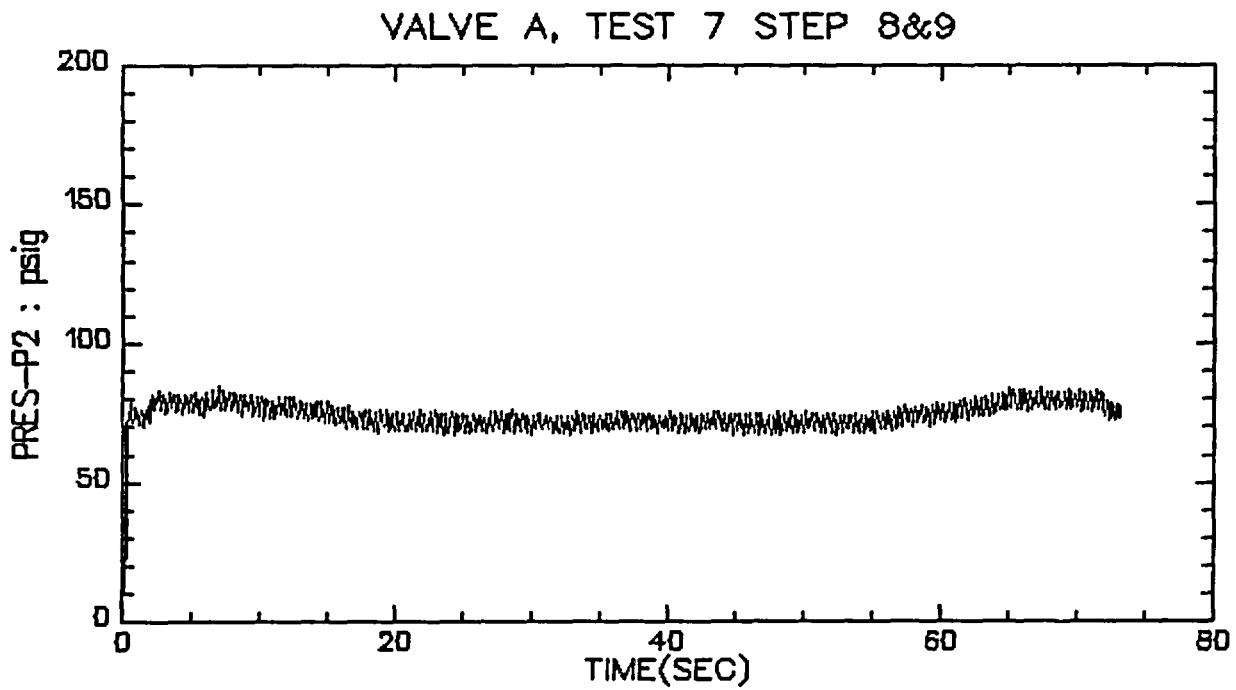
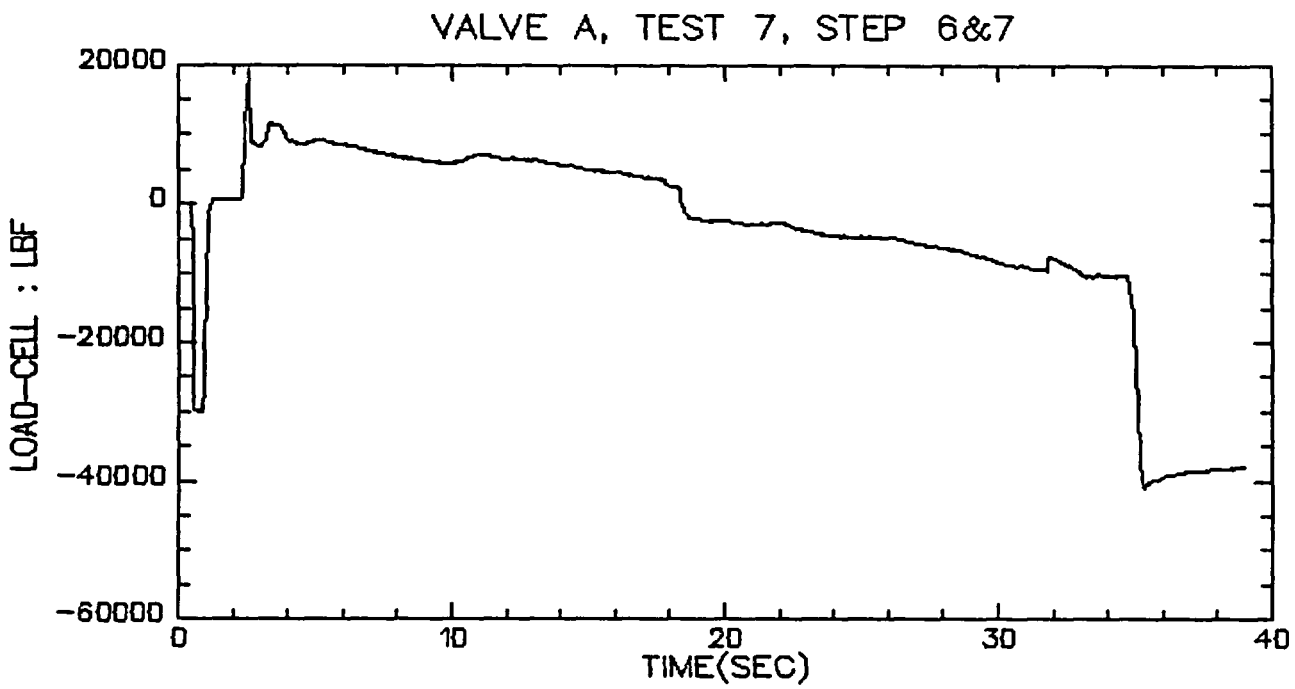

VALVE A, TEST 7, STEP 8&9

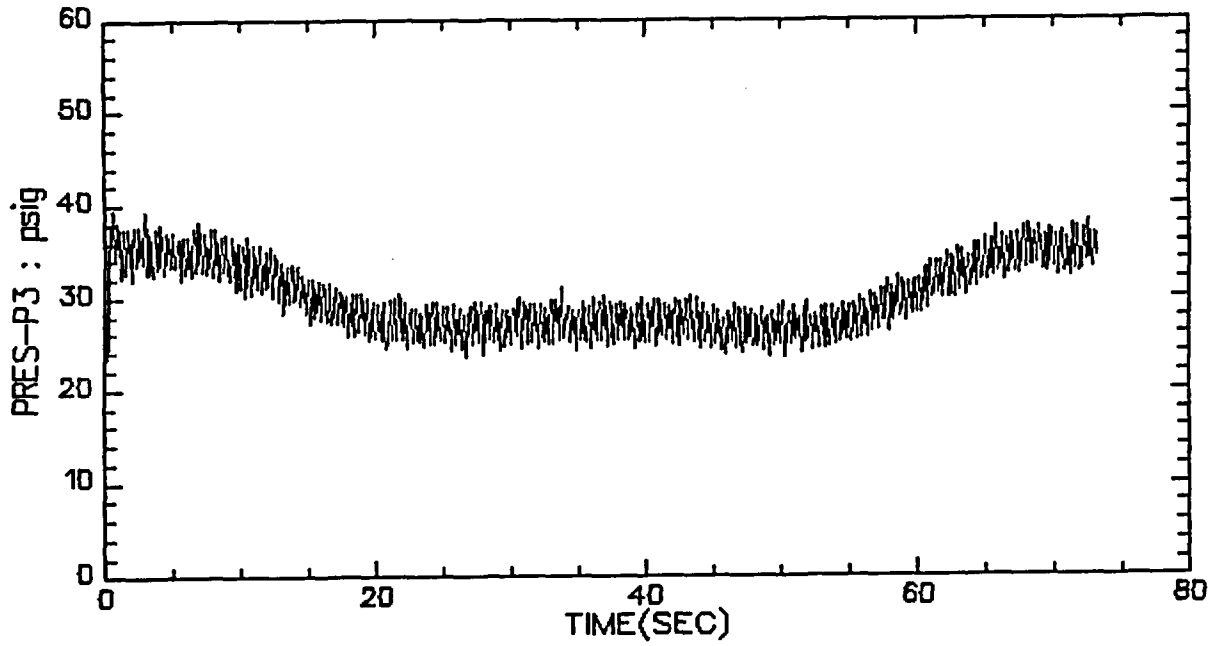

VALVE A, TEST 7 STEP 8&9

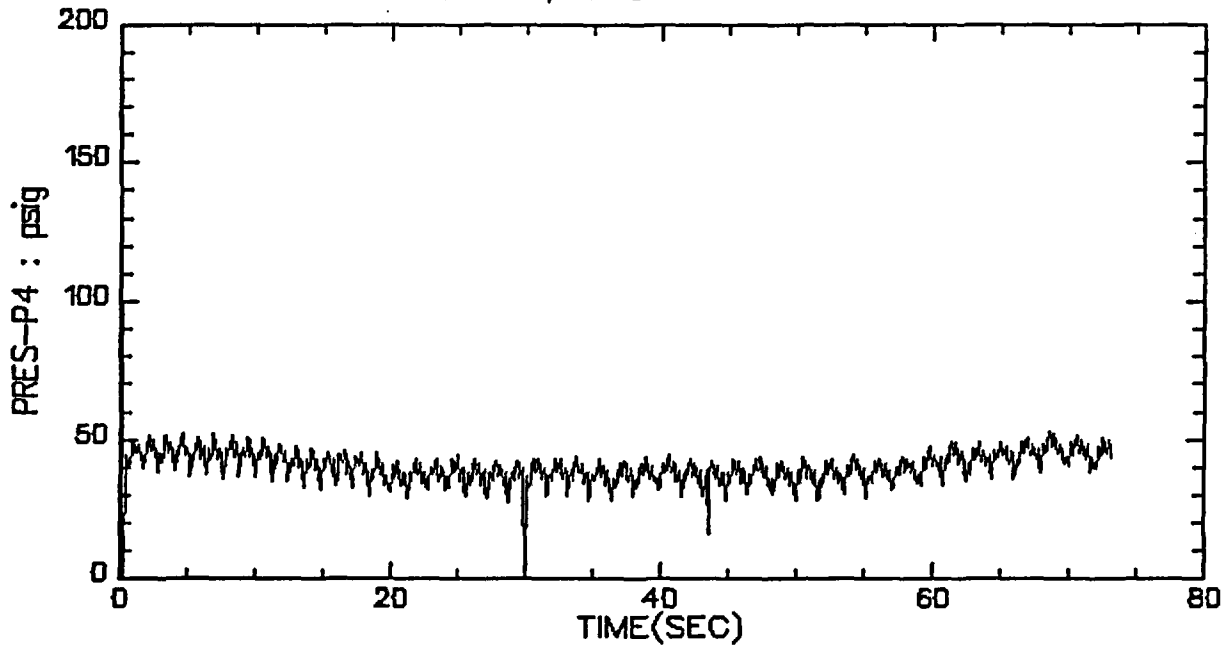

VALVE A, TEST 7 STEP 8&9

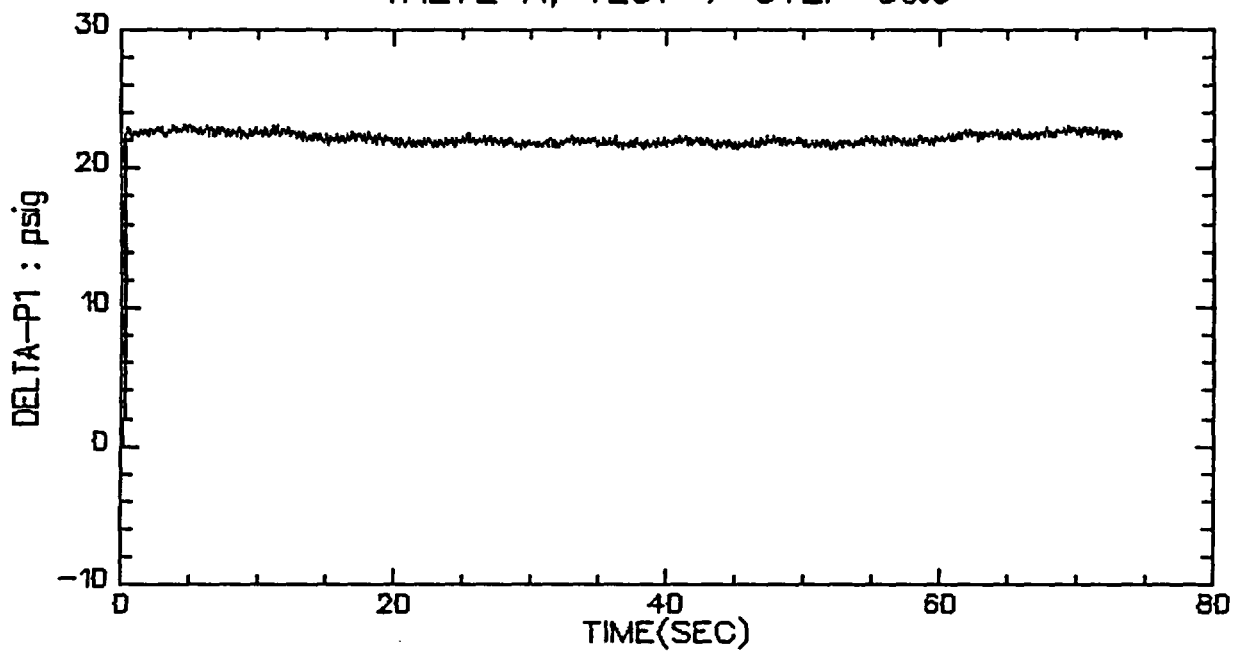

VALVE A, TEST 7 STEP 8&9

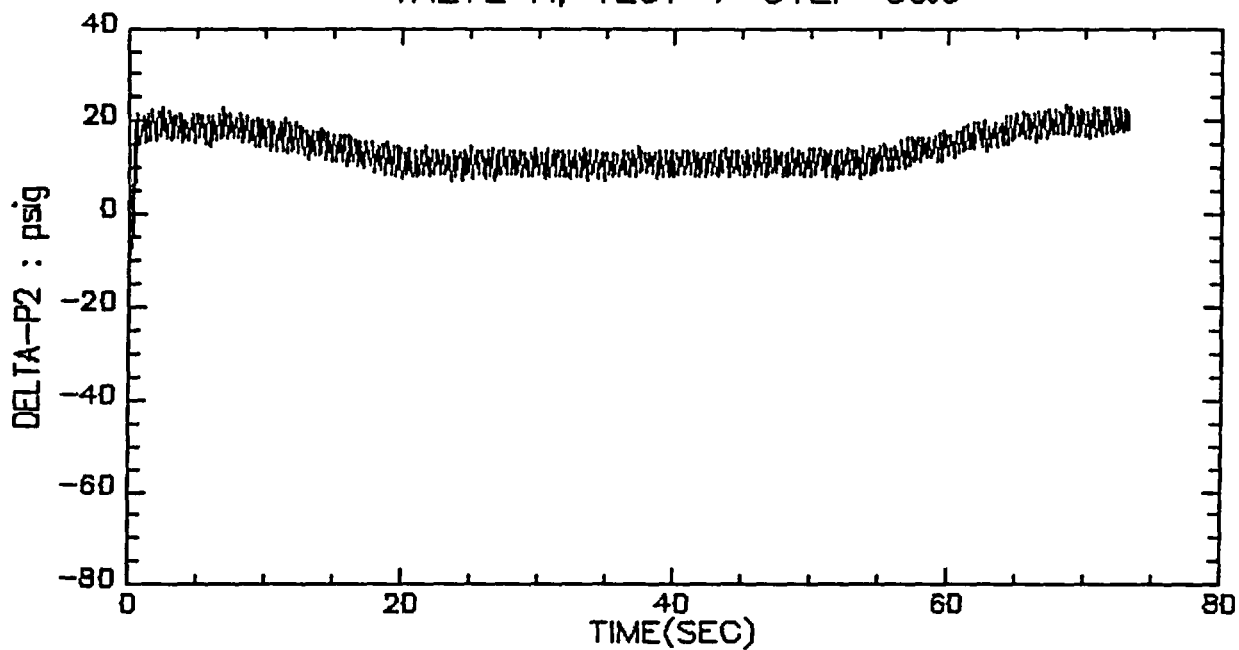

VALVE A, TEST 7 STEP 8&9

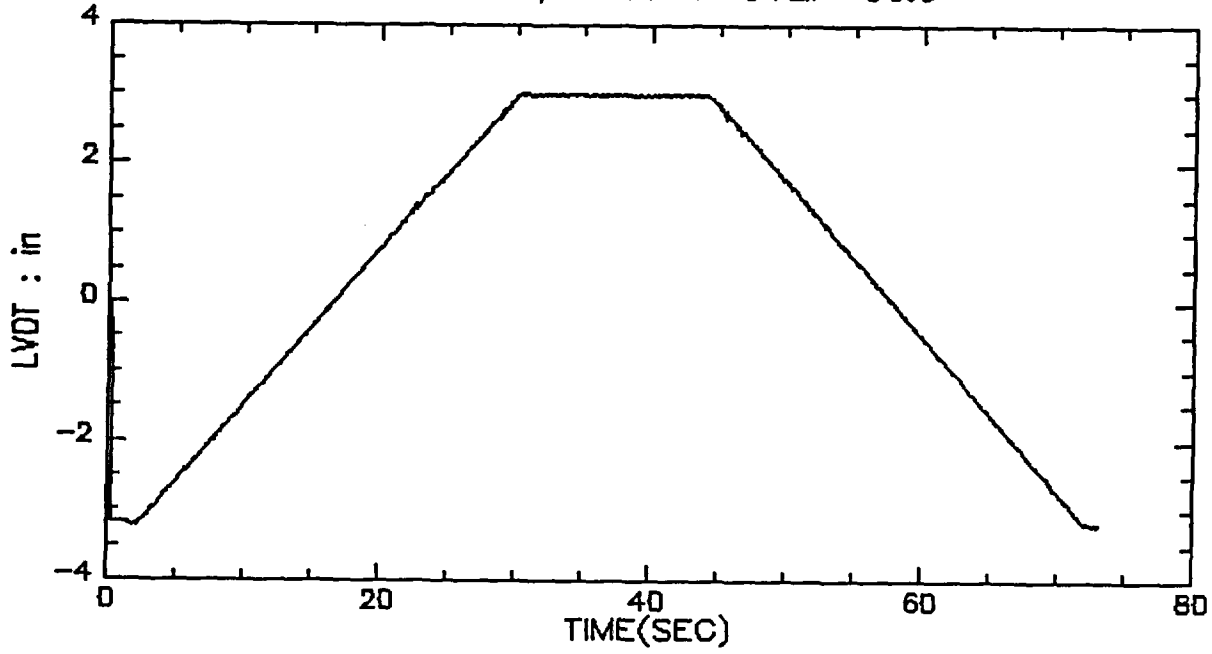

VALVE A, TEST 7 STEP 8&9

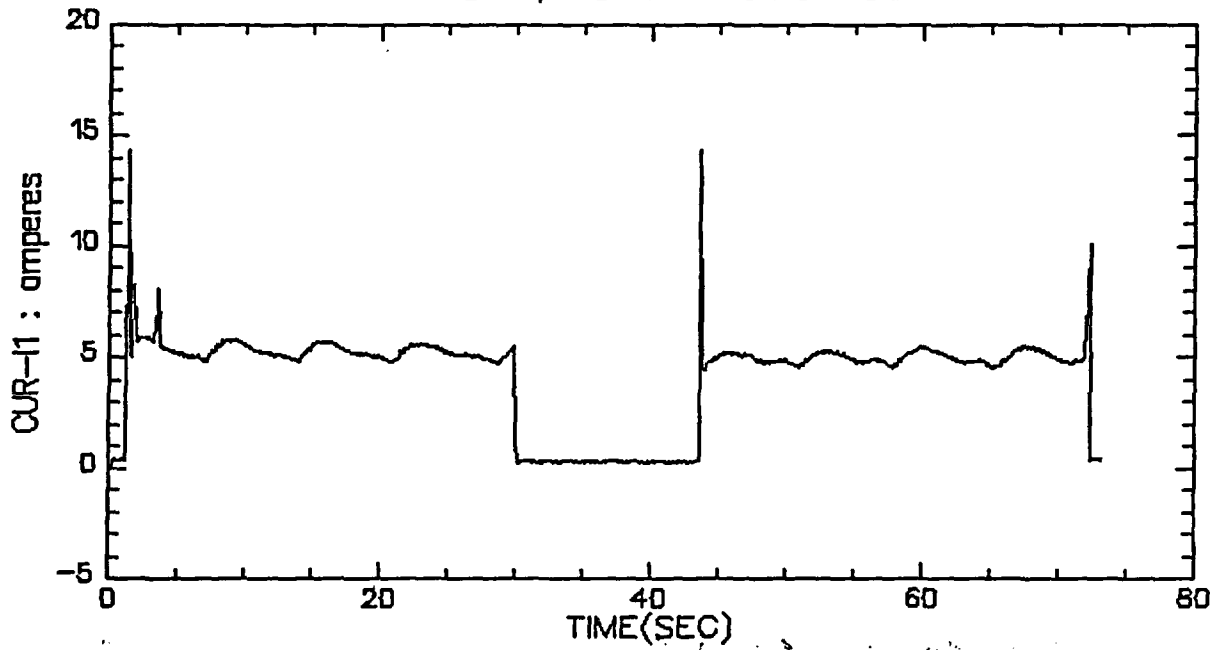

VALVE A, TEST 7 STEP 8&9

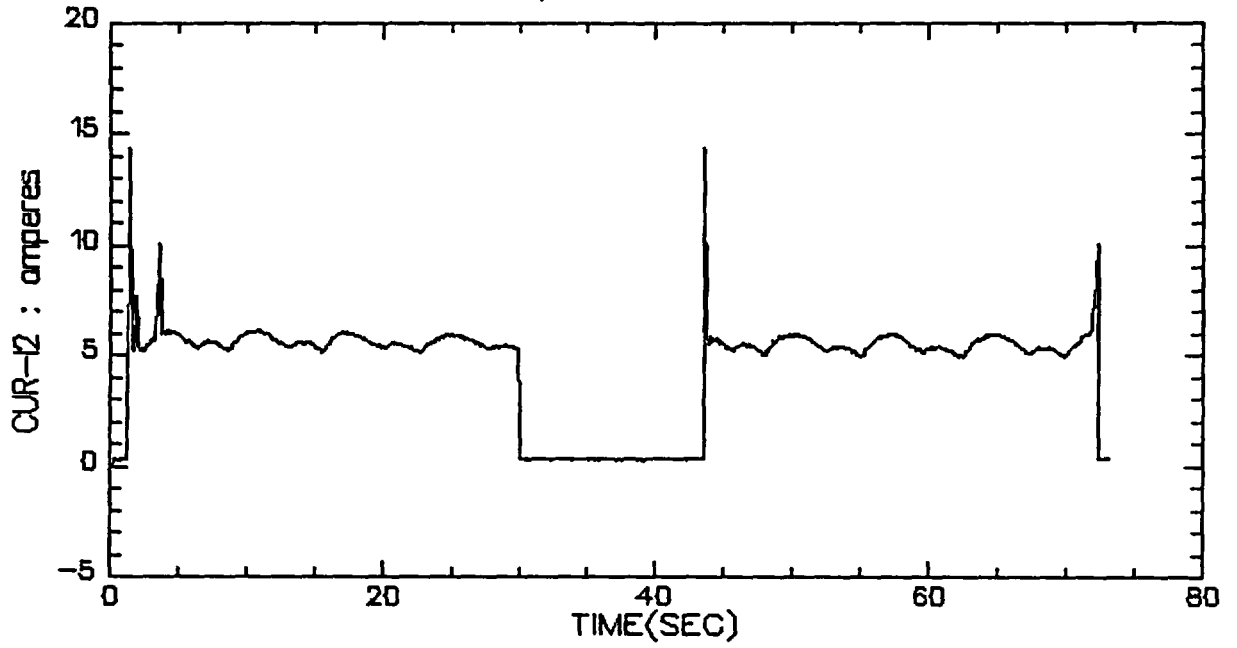

VALVE A, TEST 7 STEP 8&9

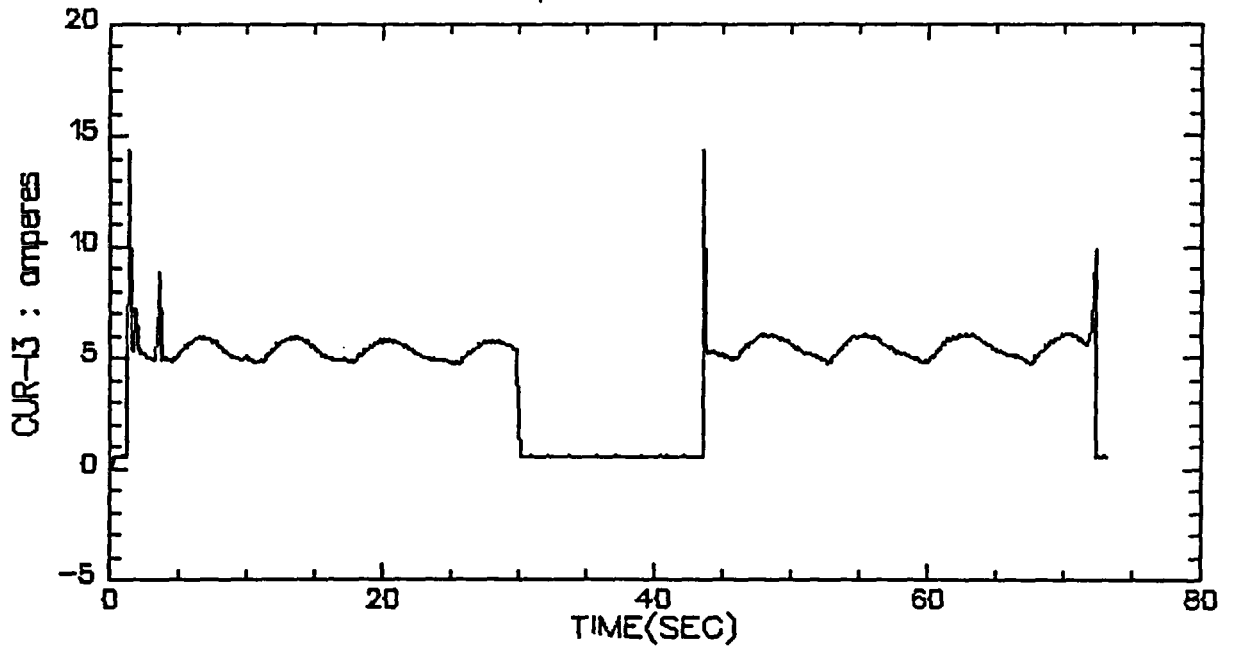

VALVE A, TEST 7 STEP 8&9

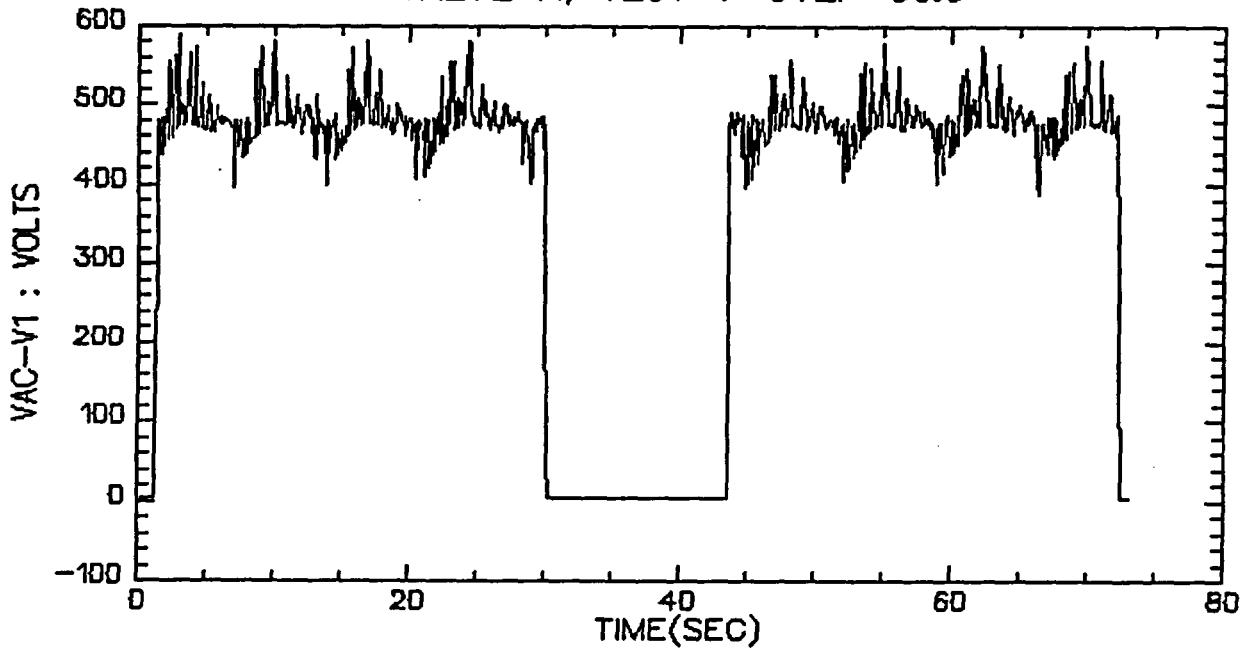

VALVE A, TEST 7 STEP 8&9

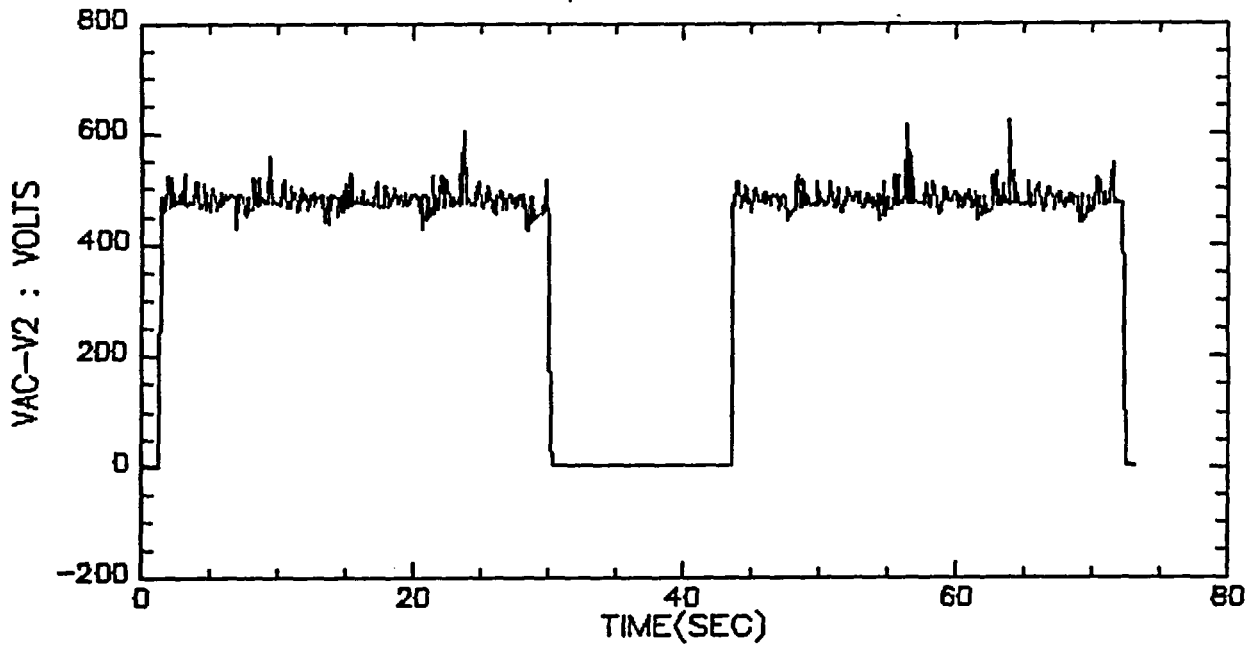

VALVE A, TEST 7 STEP 8&9

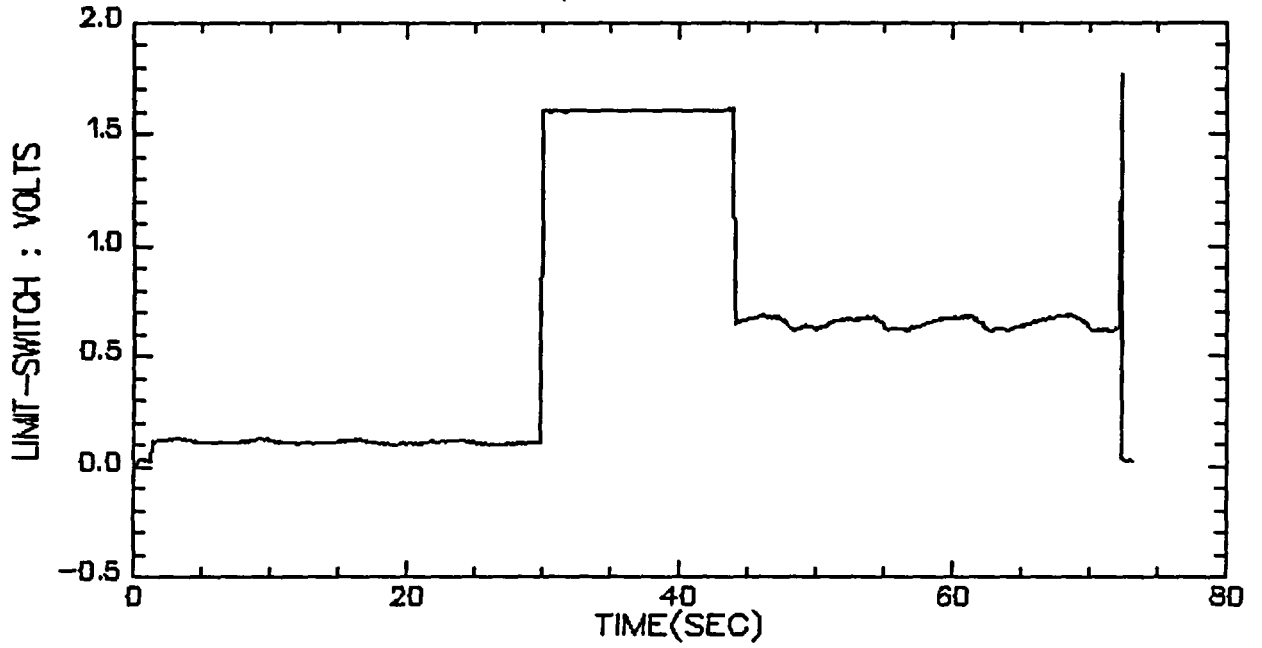

VALVE A, TEST 7 STEP 8&9

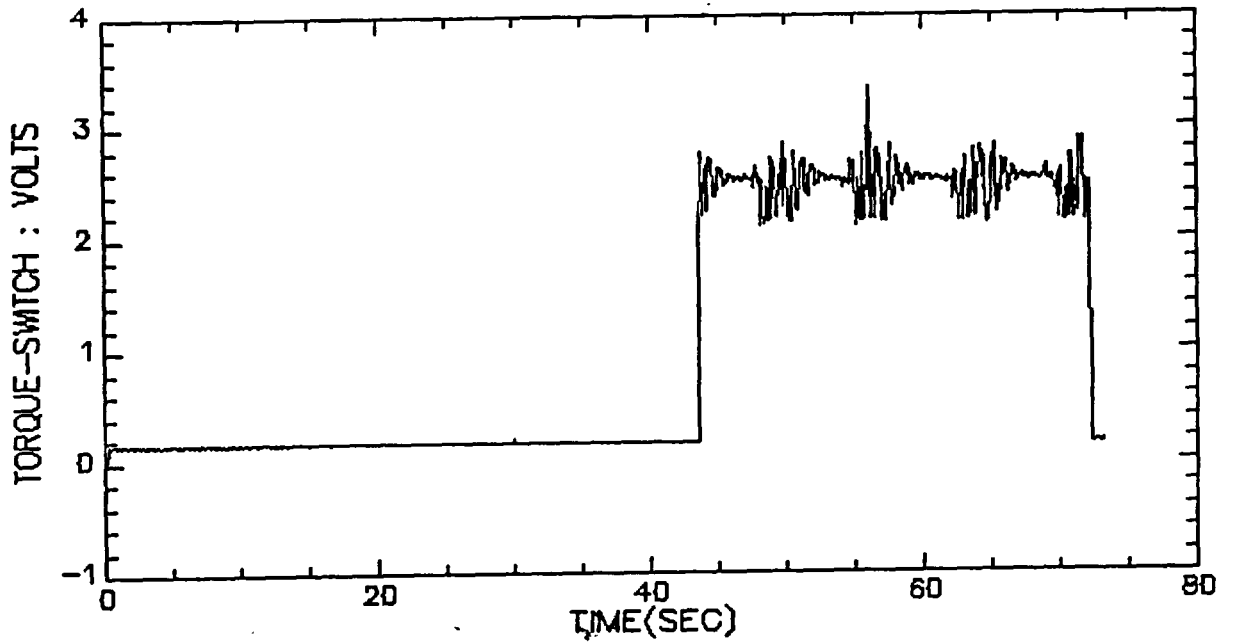

VALVE A, TEST 8, STEP 1

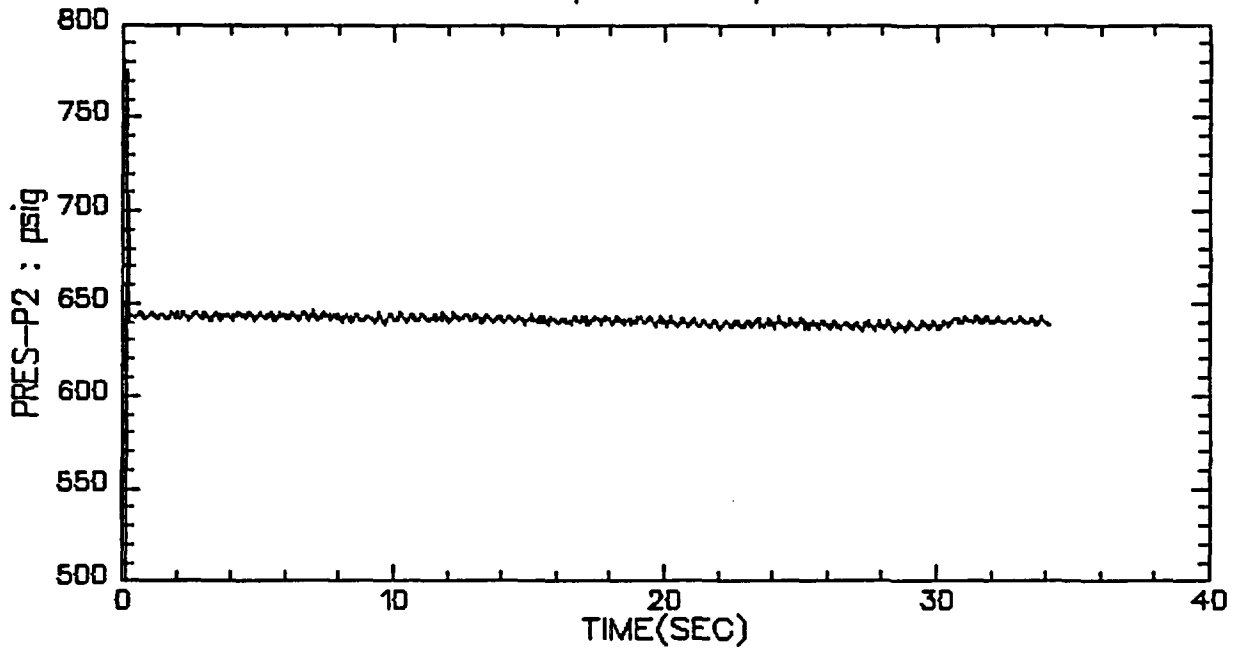

VALVE A, TEST 8, STEP 1

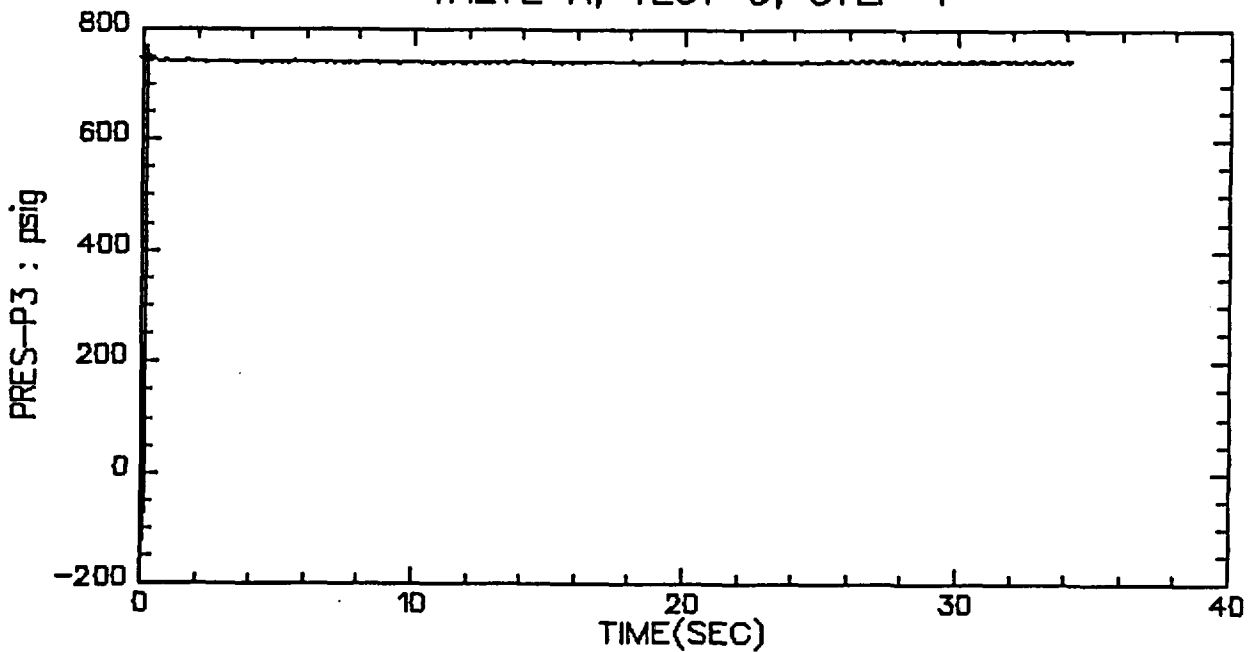

VALVE A, TEST 8, STEP 1

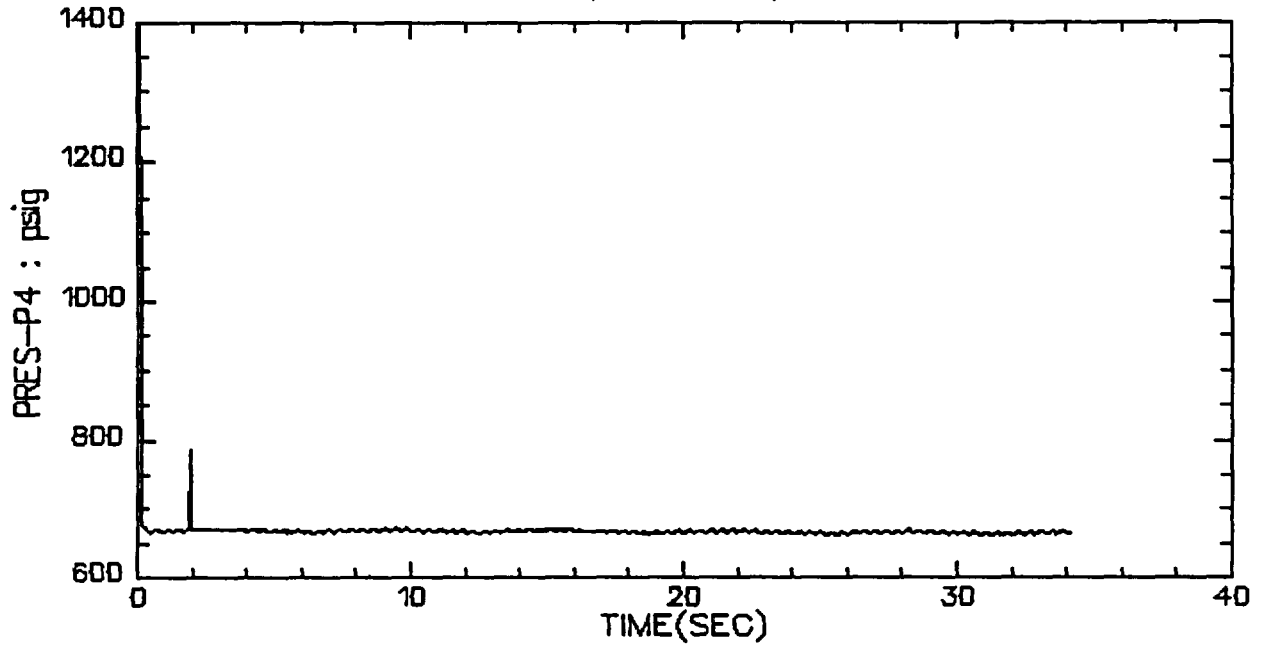

VALVE A, TEST 8, STEP 1

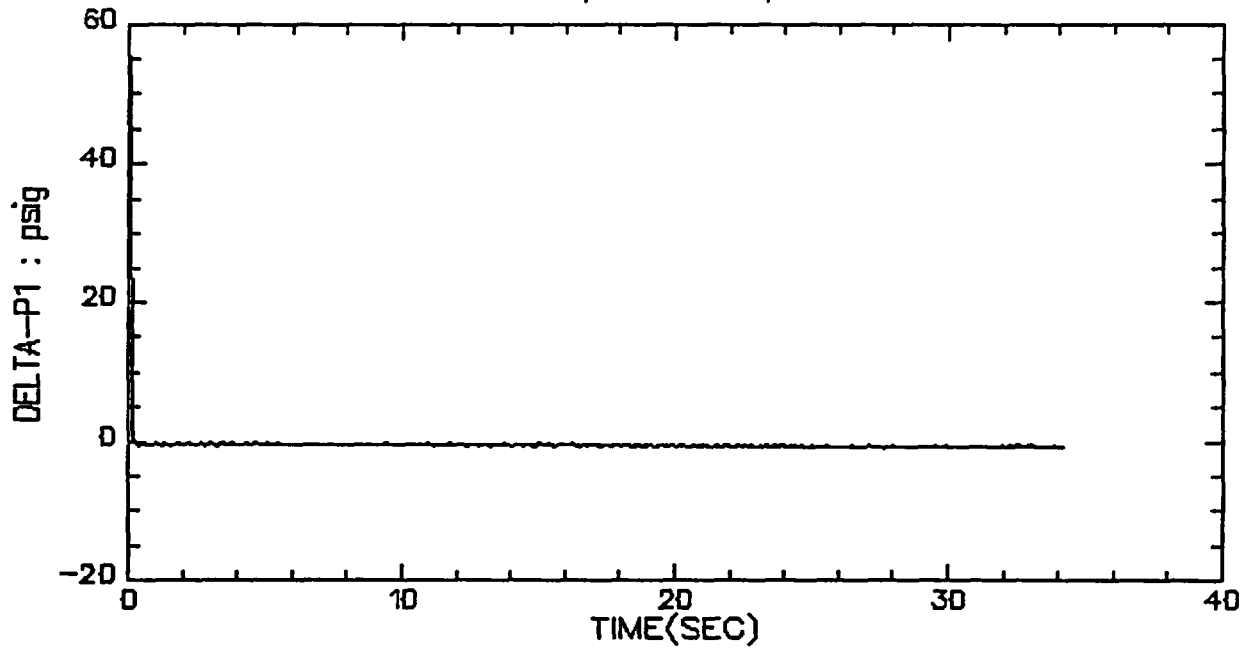

VALVE A, TEST 8, STEP 1

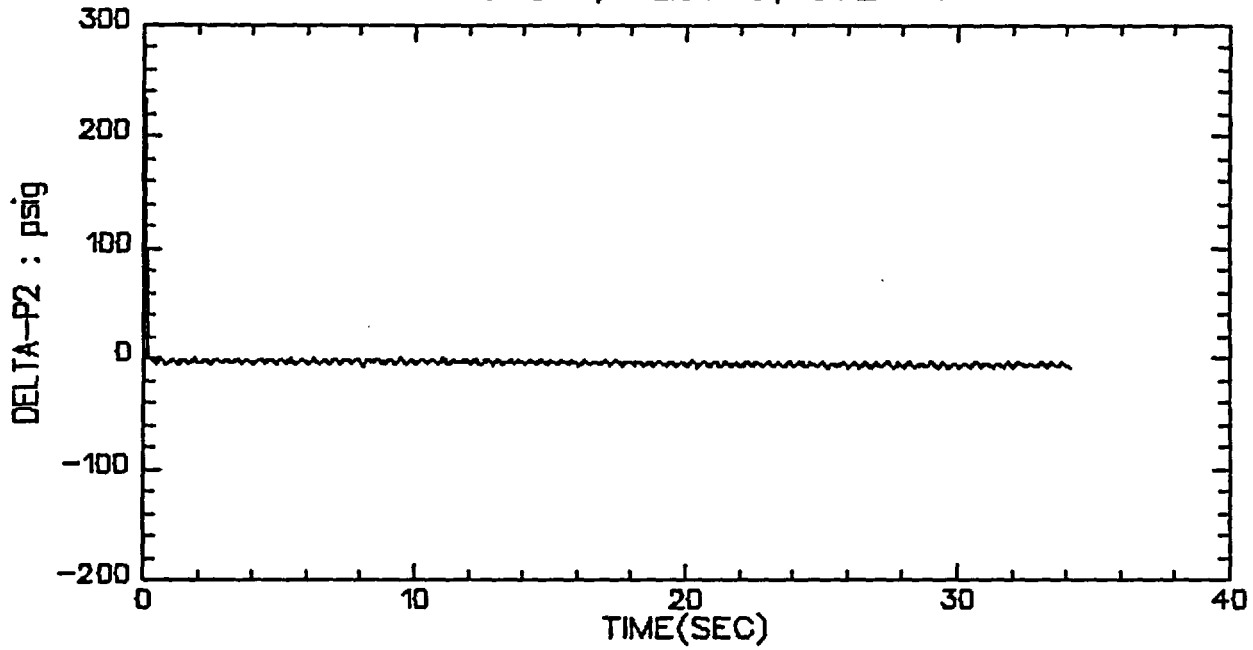

VALVE A, TEST 8, STEP 1

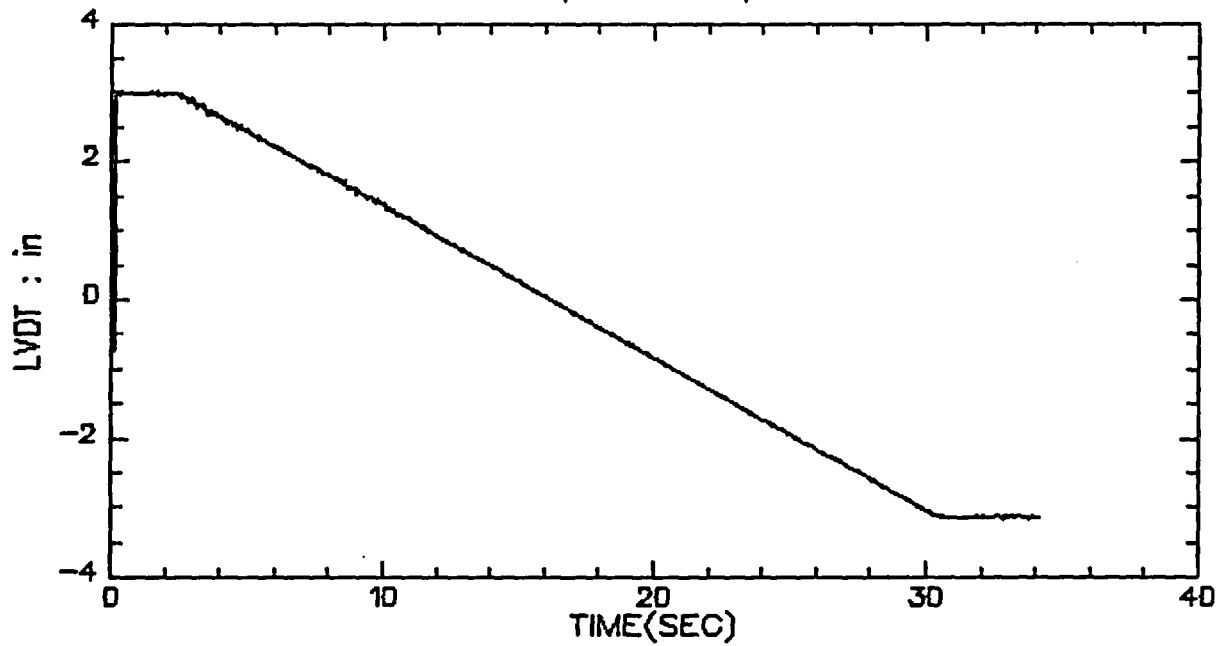

VALVE A, TEST 8, STEP 1

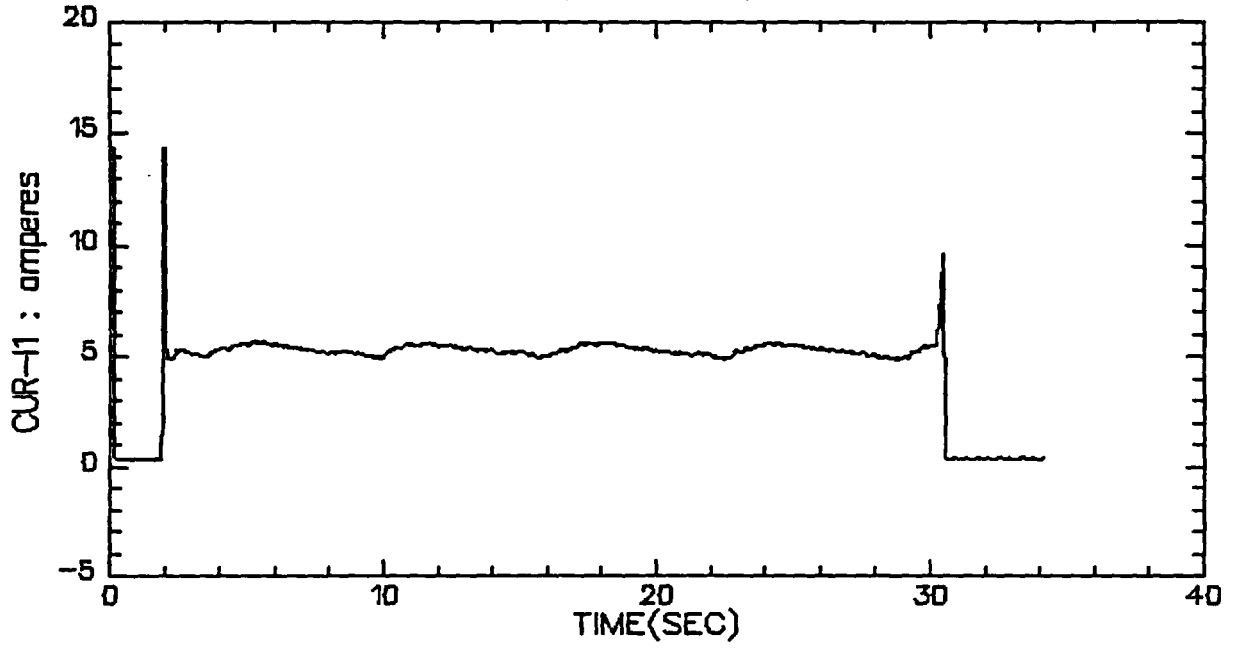

VALVE A, TEST 8, STEP 1

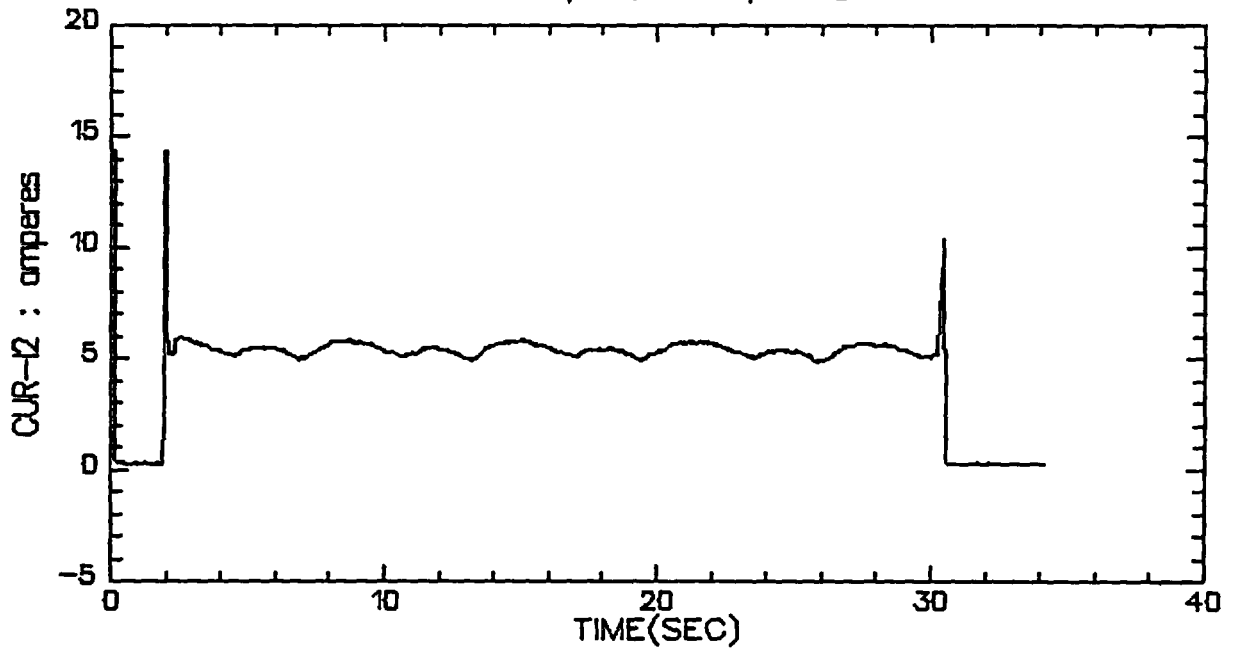

VALVE A, TEST 8, STEP 1

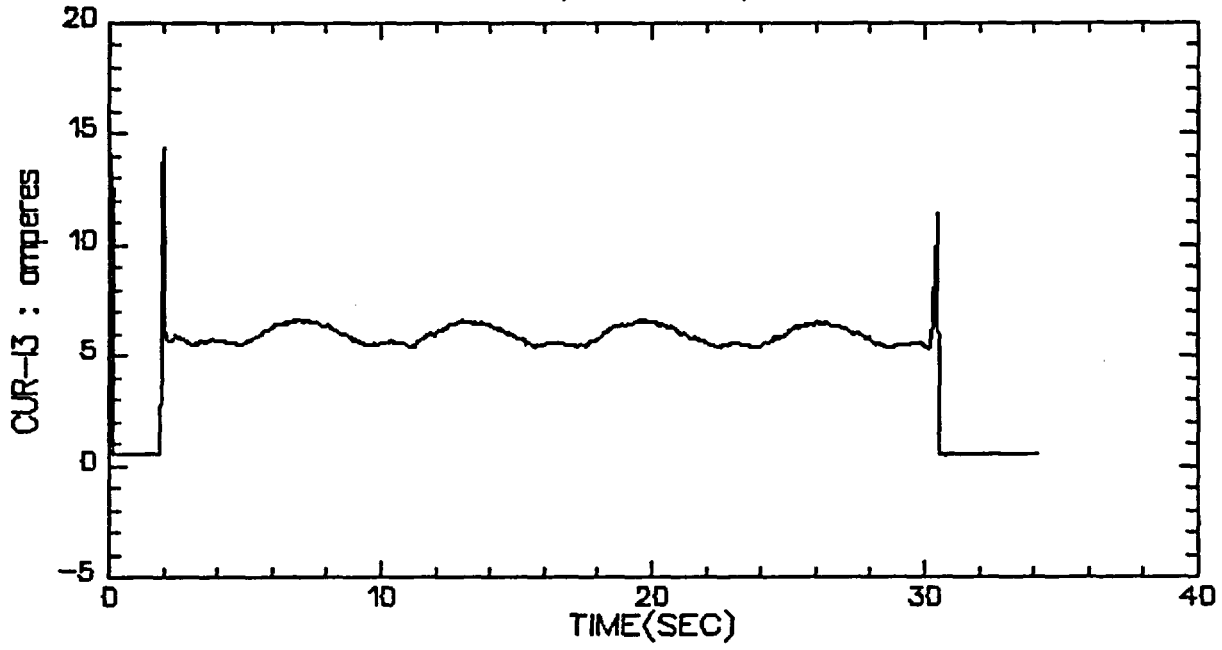

VALVE A, TEST 8, STEP 1

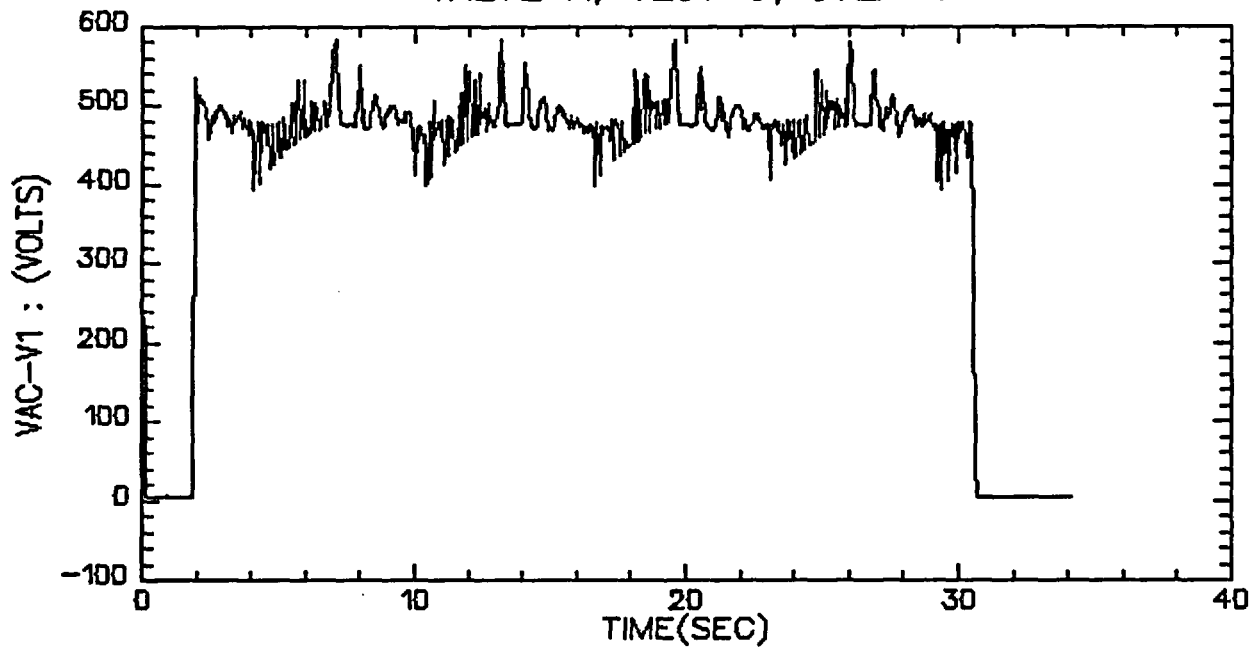

VALVE A, TEST 8, STEP 1

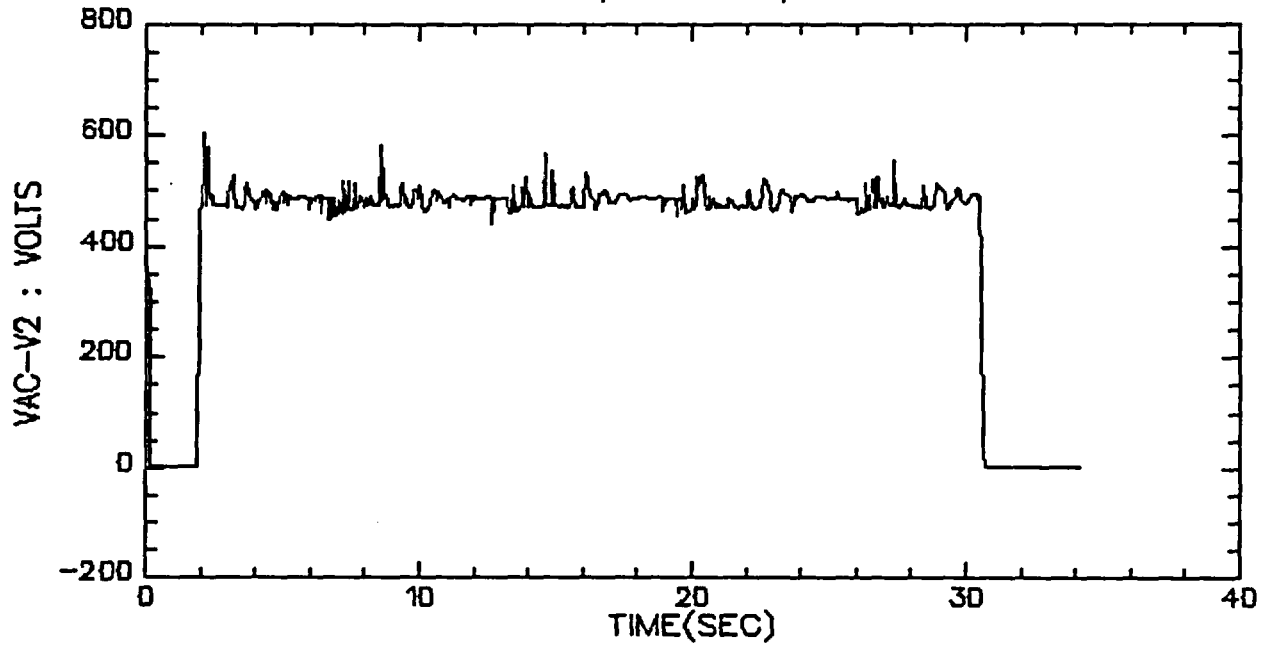

VALVE A, TEST 8, STEP 1

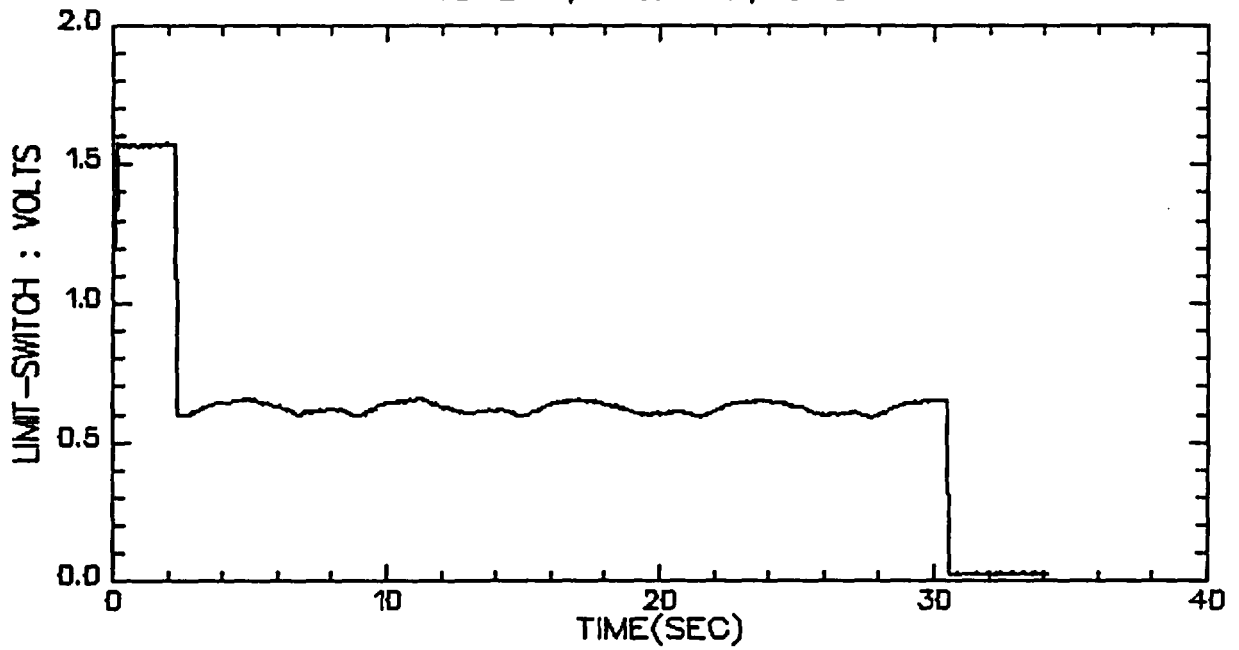

VALVE A, TEST 8, STEP 1

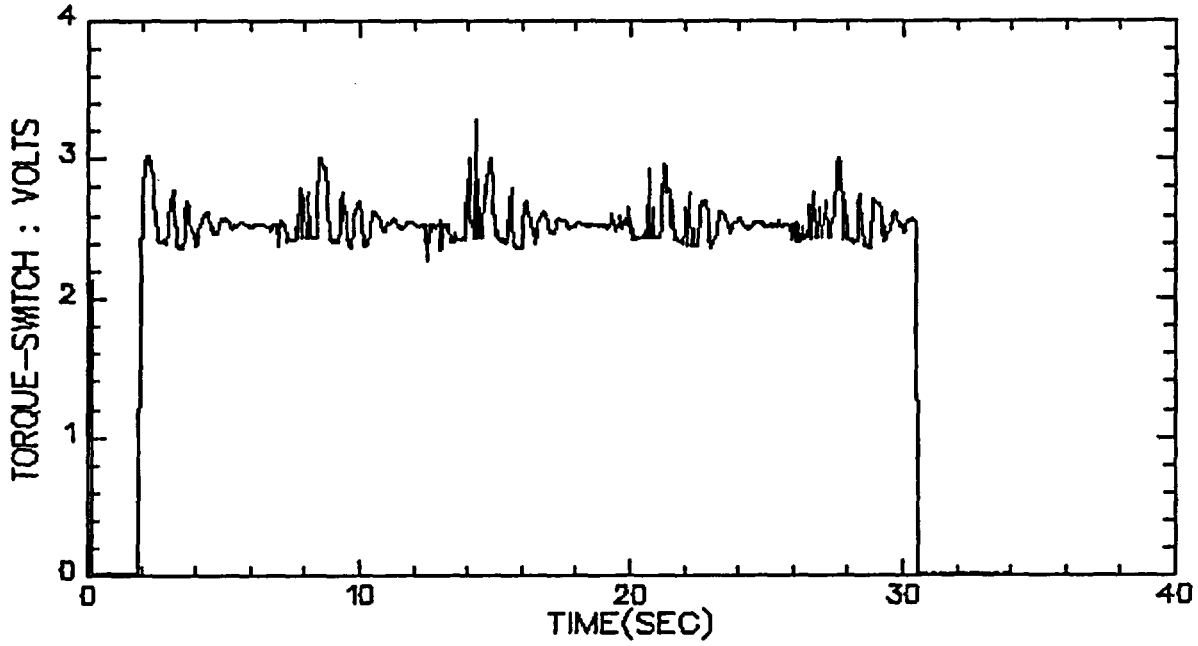

VALVE A, TEST 8, STEP 1

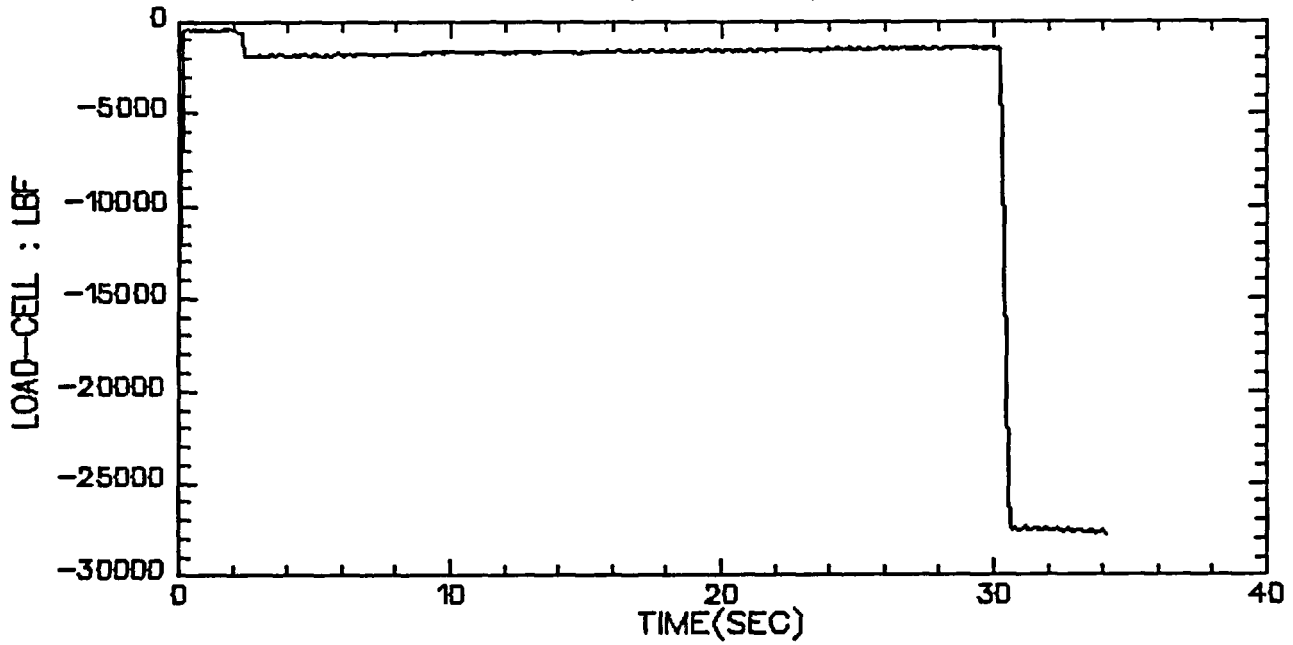

VALVE A, TEST 8, STEP 2

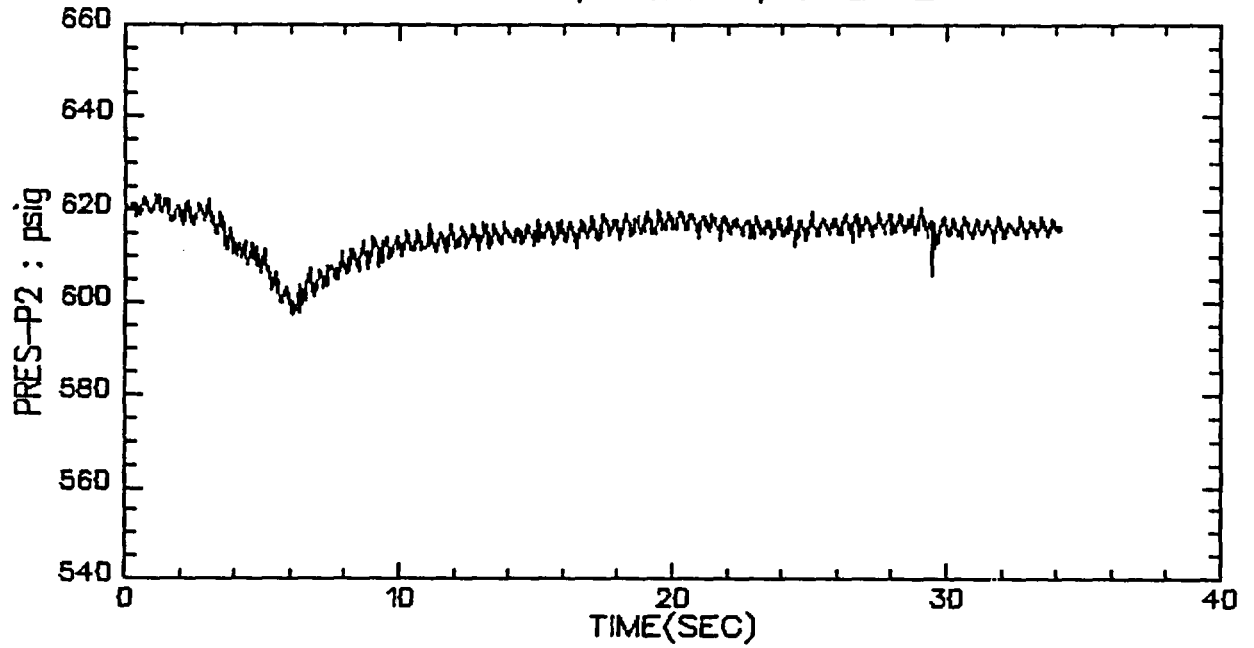

VALVE A, TEST 8, STEP 2

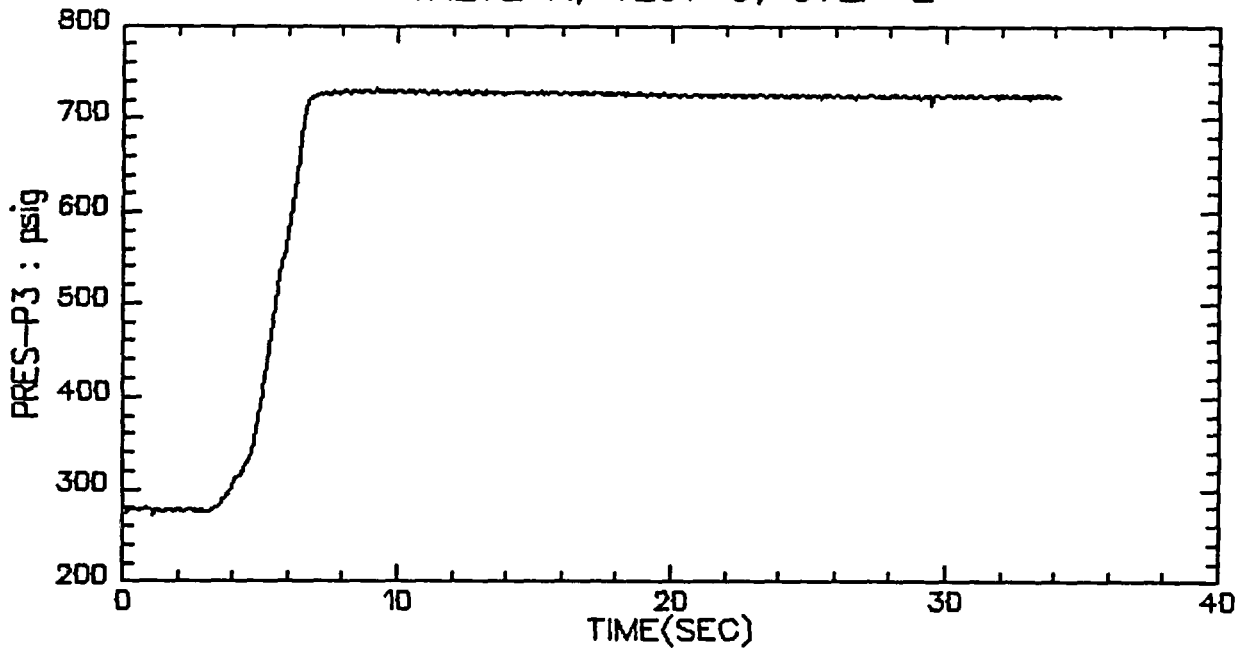

VALVE A, TEST 8, STEP 2

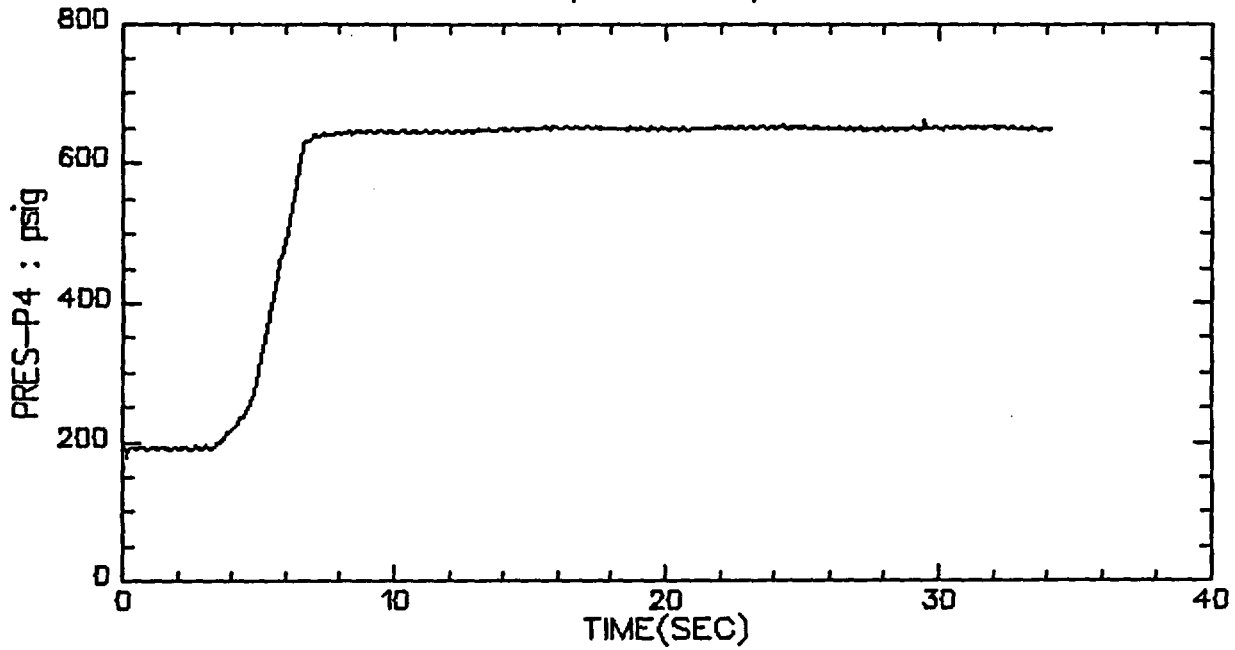

VALVE A, TEST 8, STEP 2

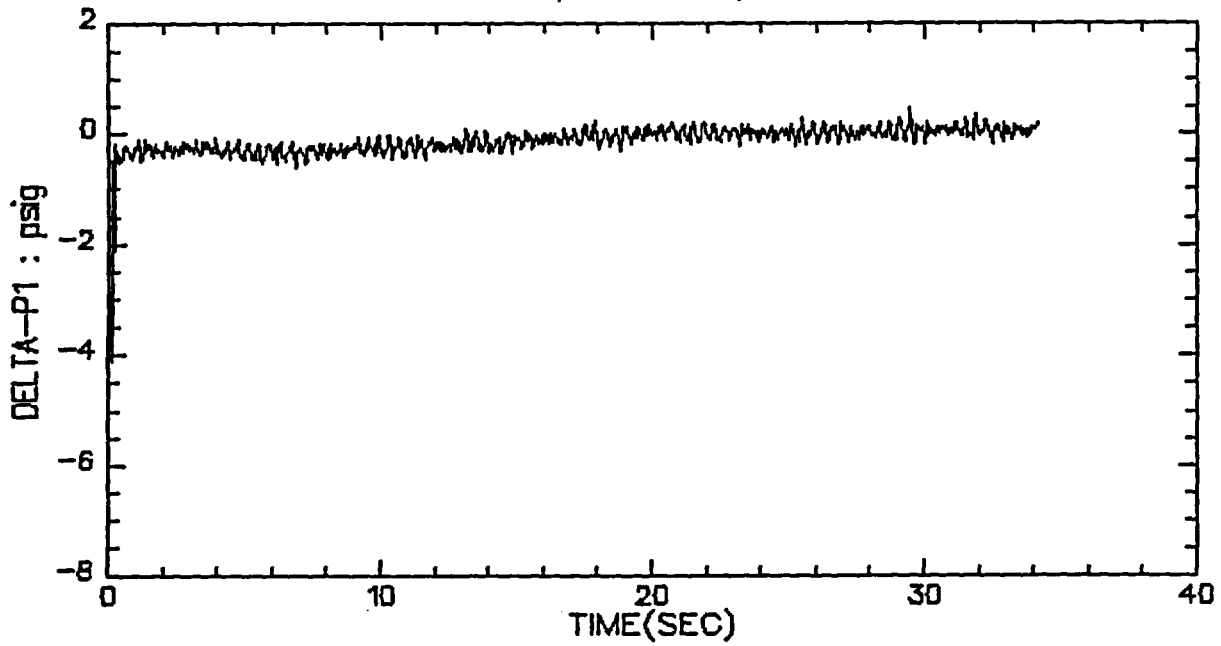

VALVE A, TEST 8, STEP 2

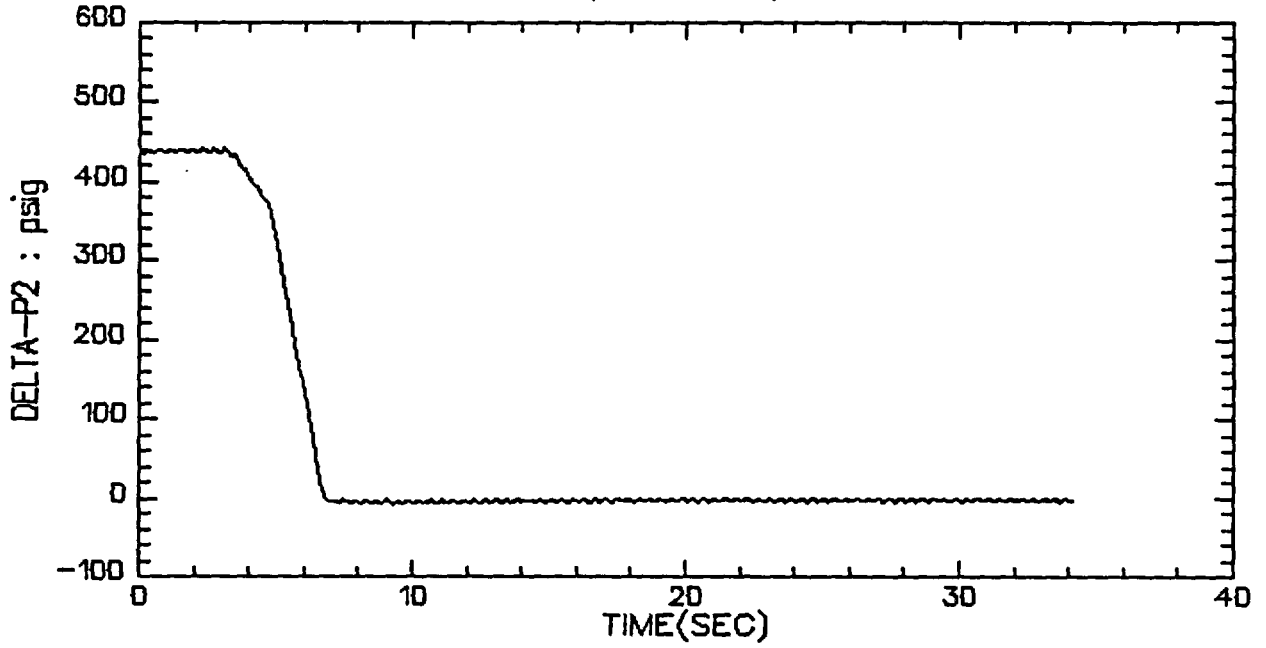

VALVE A, TEST 8, STEP 2

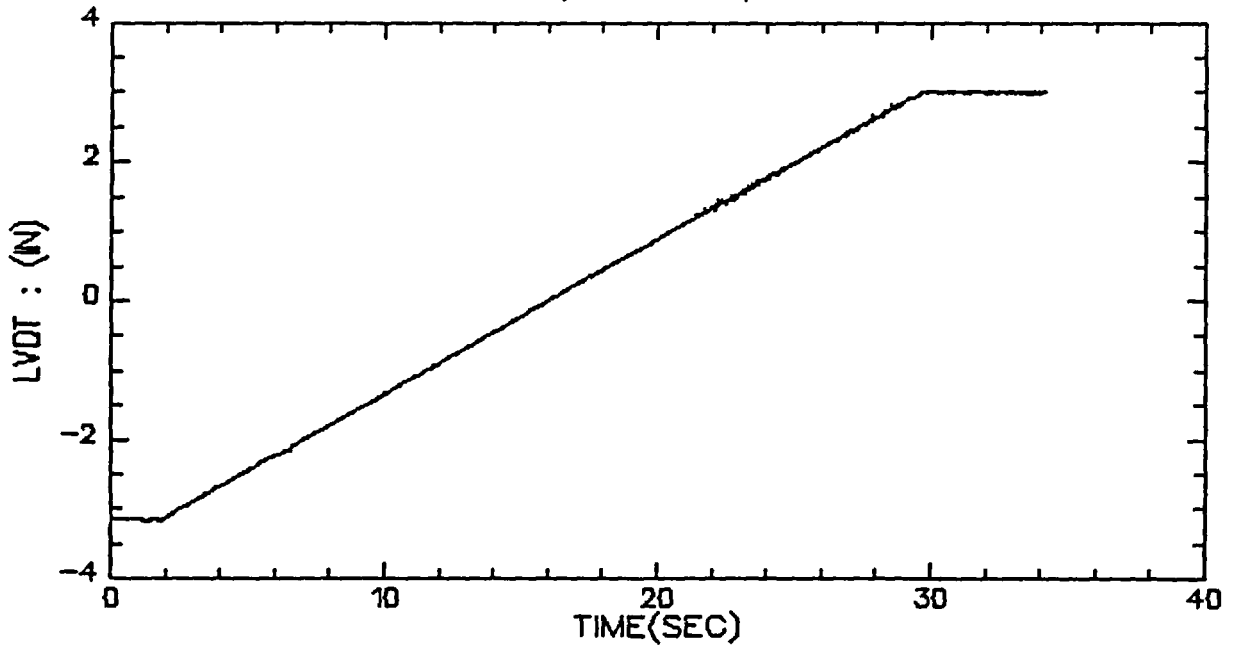

VALVE A, TEST 8, STEP 2

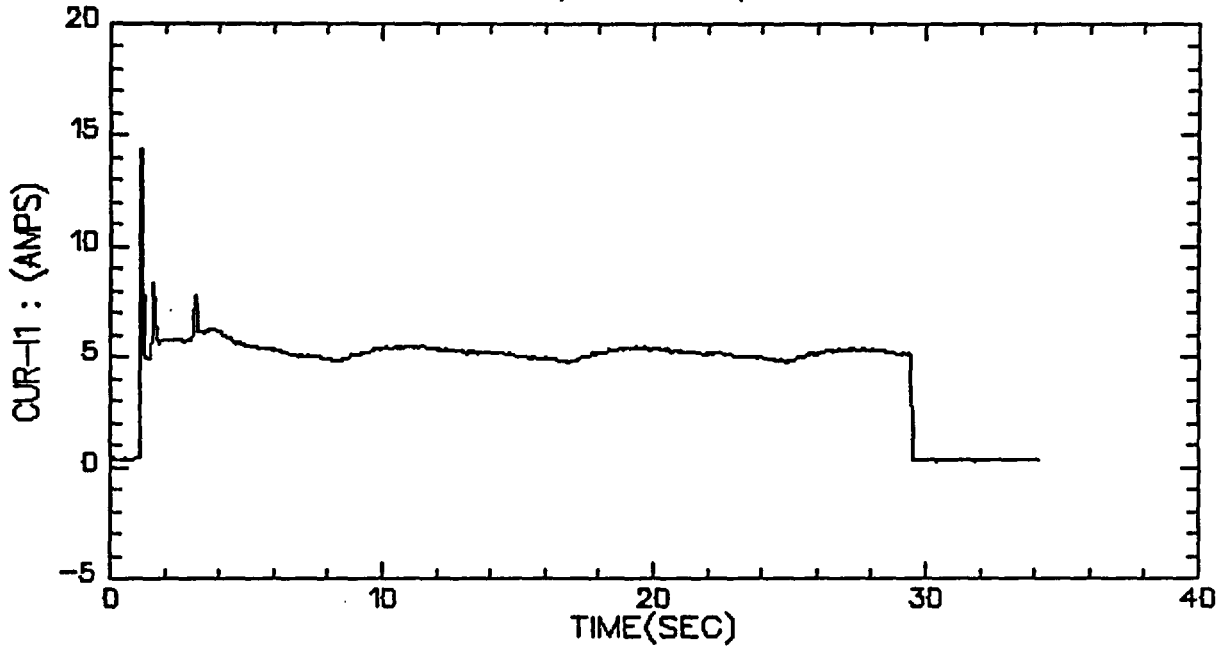

VALVE A, TEST 8, STEP 2

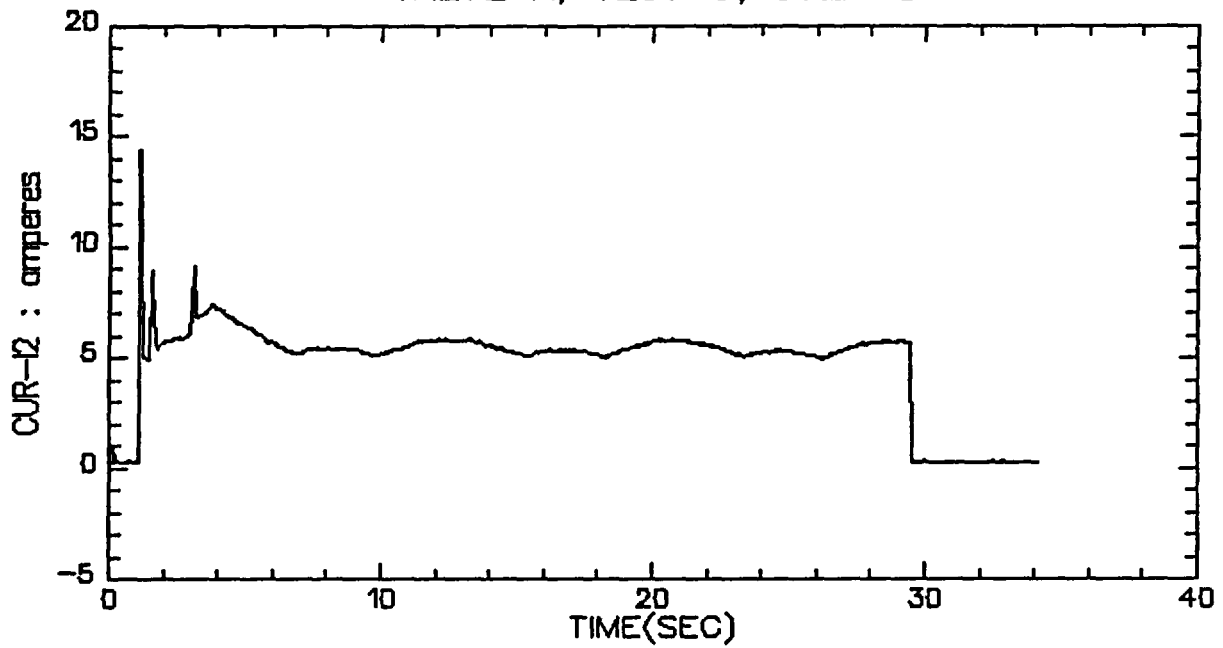

VALVE A, TEST 8, STEP 2

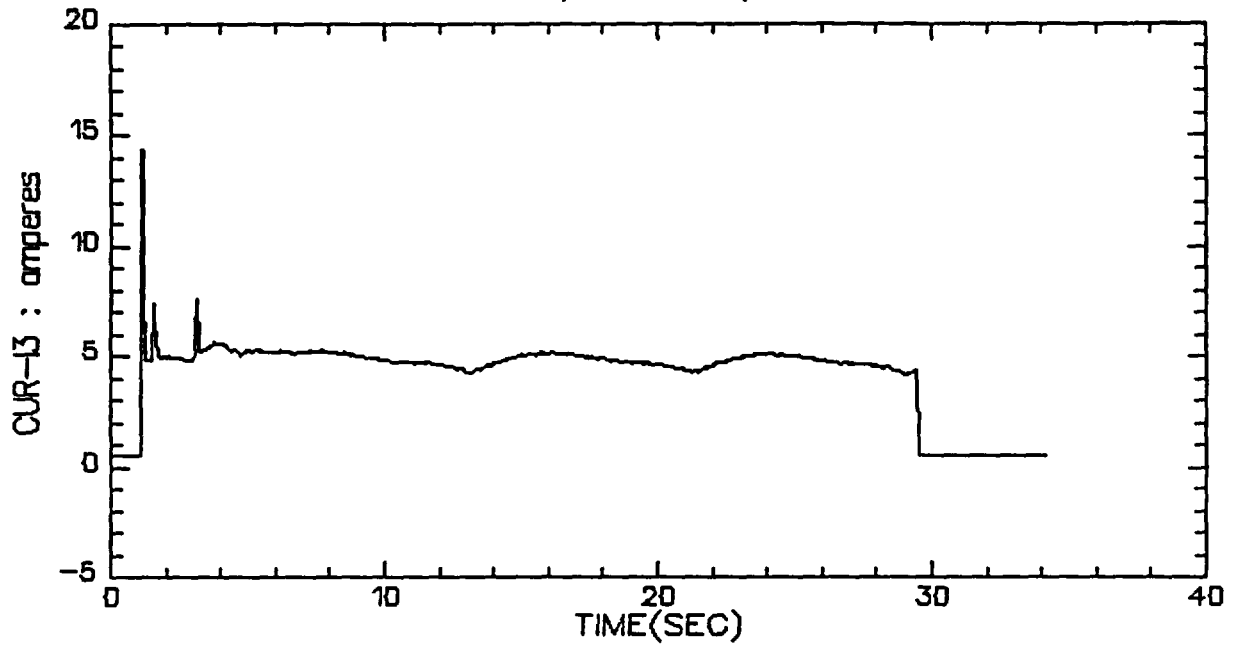

VALVE A, TEST 8, STEP 2

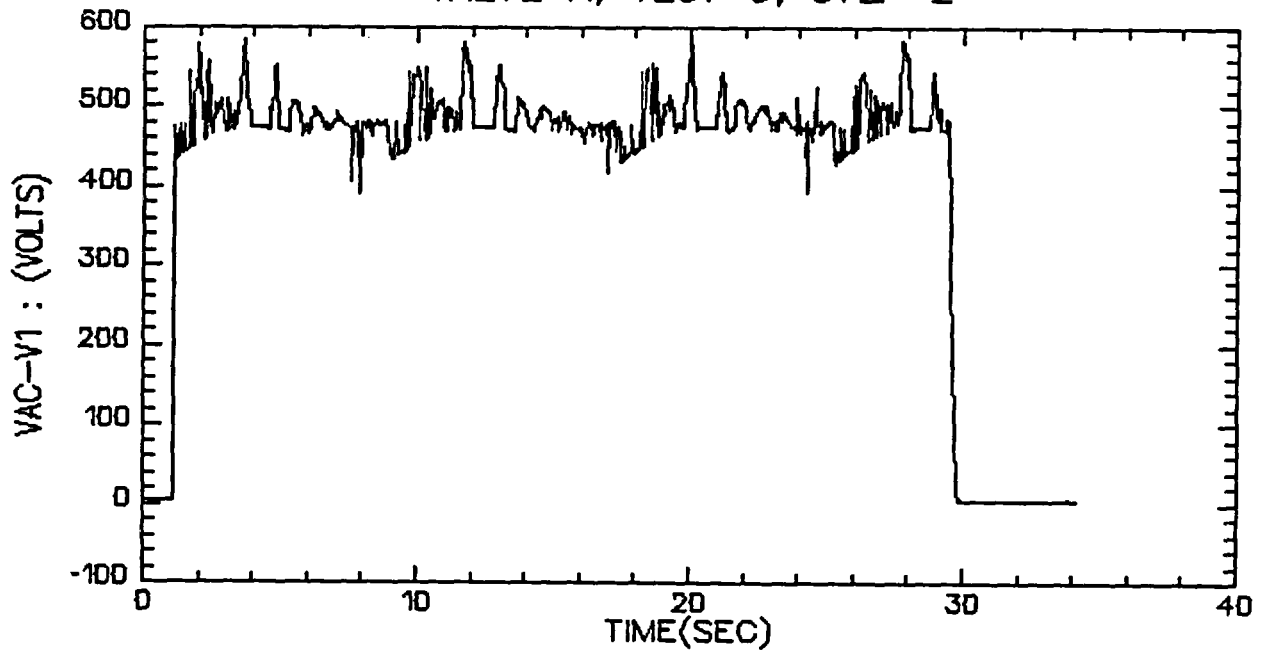

VALVE A, TEST 8, STEP 2

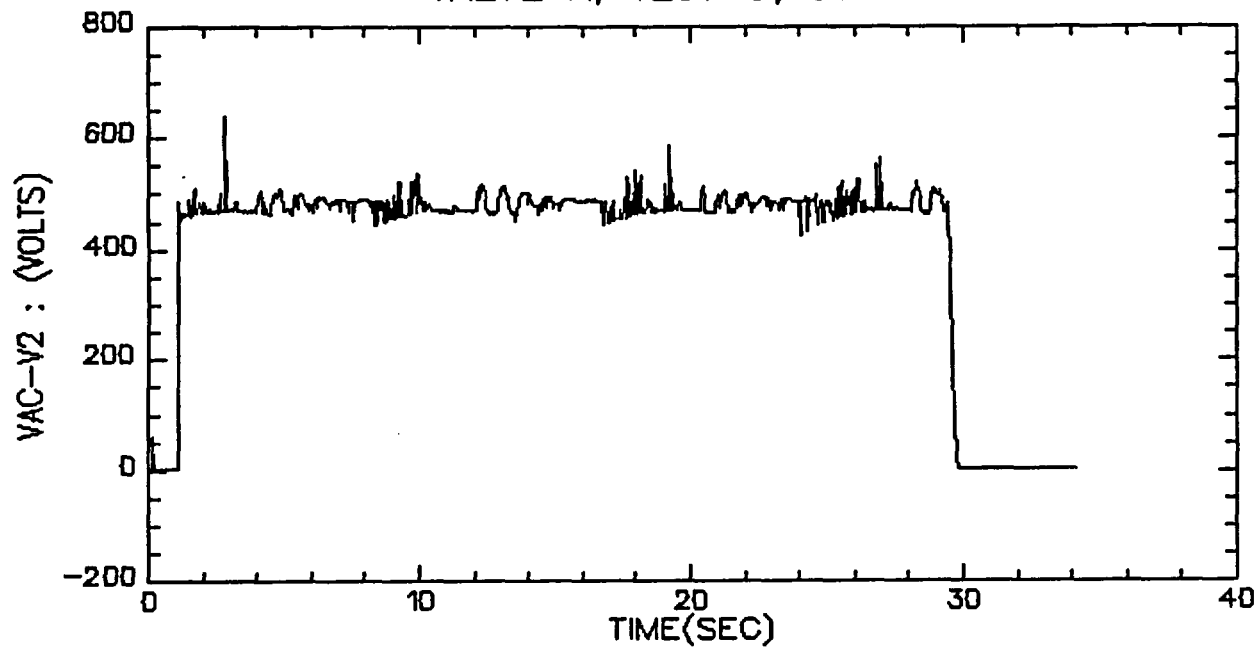

VALVE A, TEST 8, STEP 2

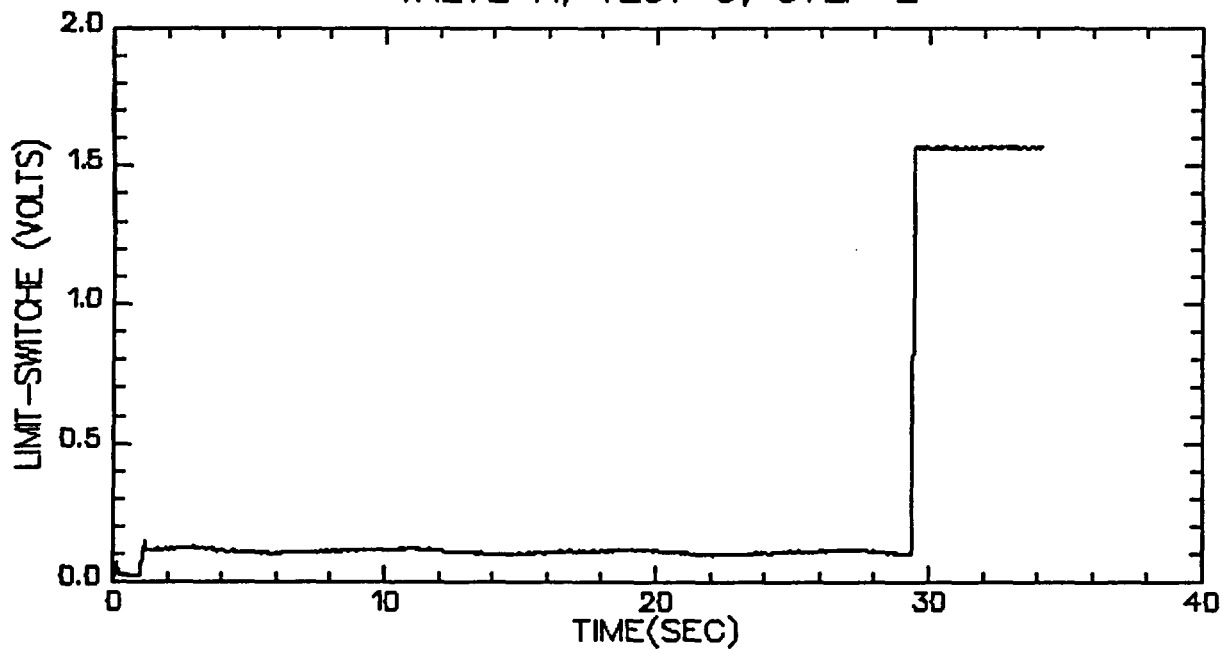

VALVE A, TEST 8, STEP 2

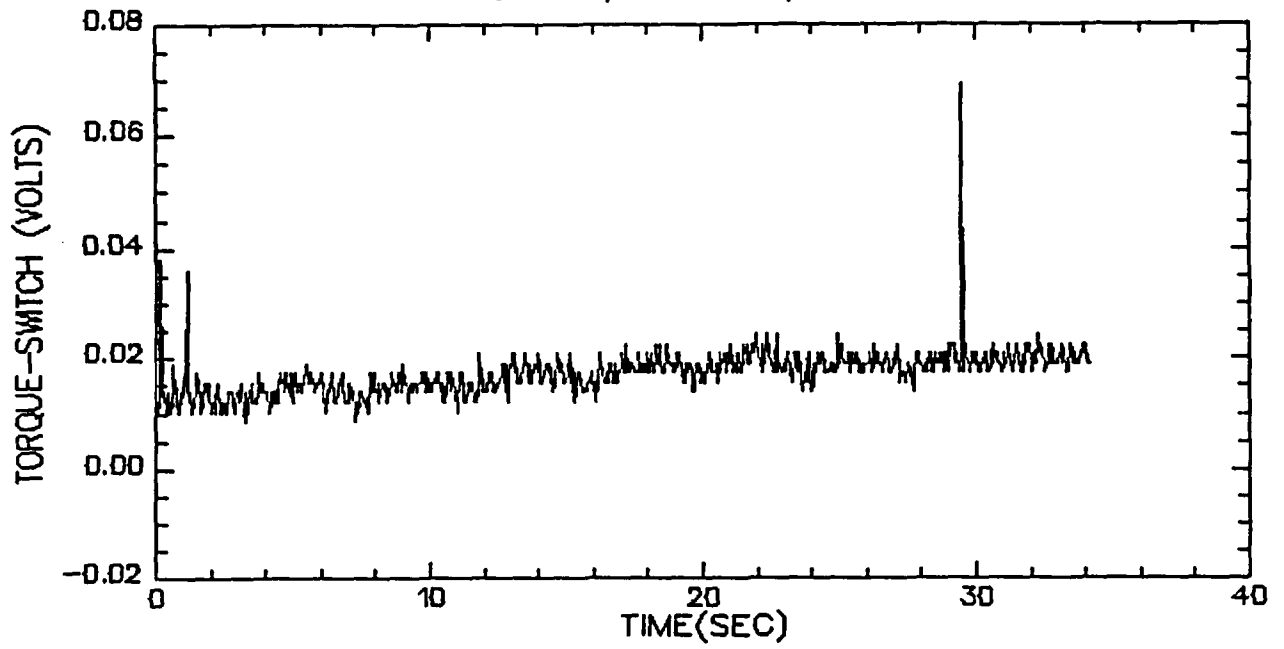

VALVE A, TEST 8, STEP 2

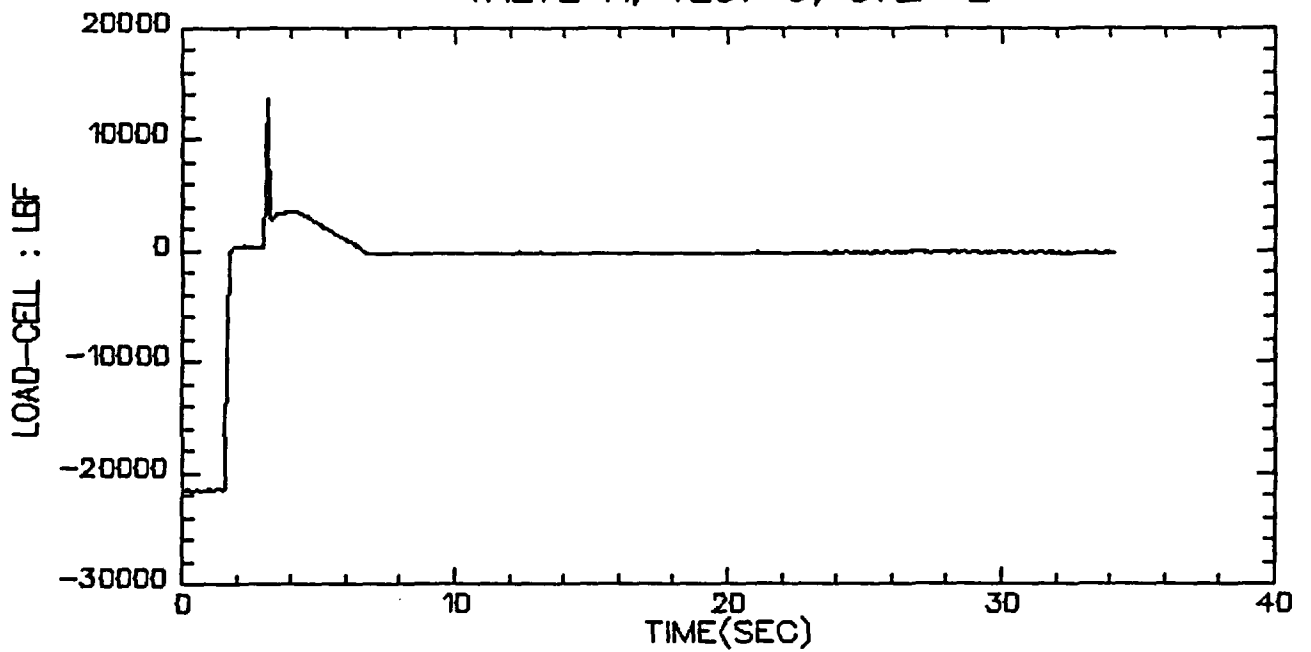

VALVE A, TEST 8, STEP 3&4

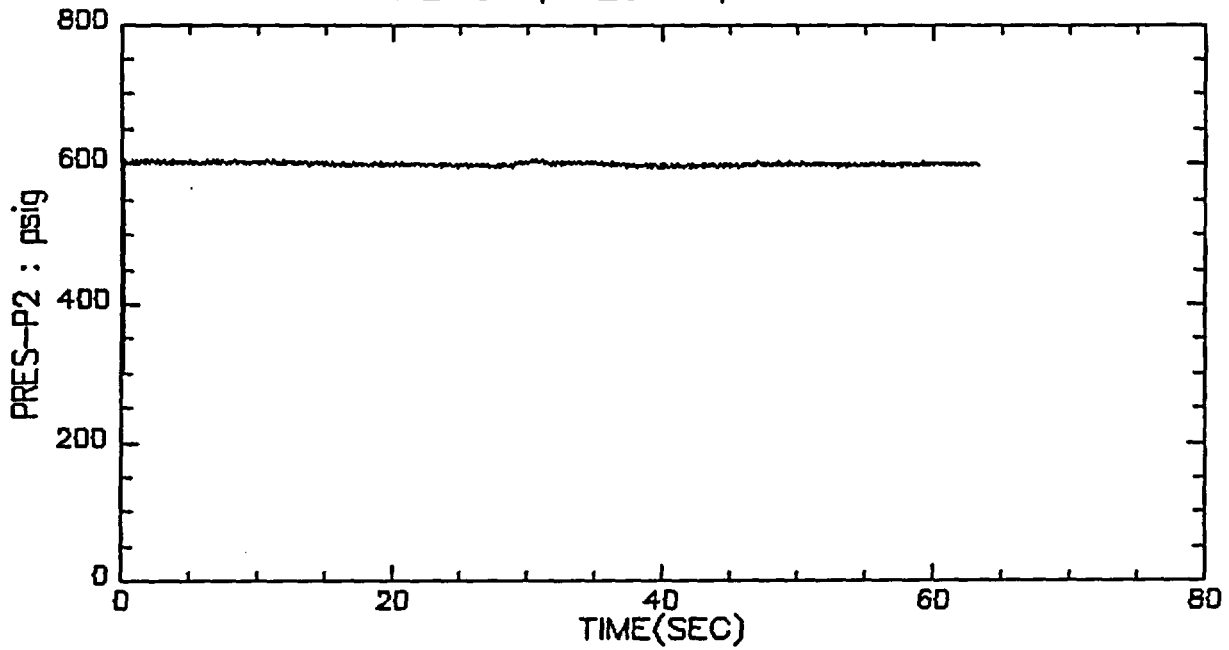

VALVE A, TEST 8, STEP 3&4

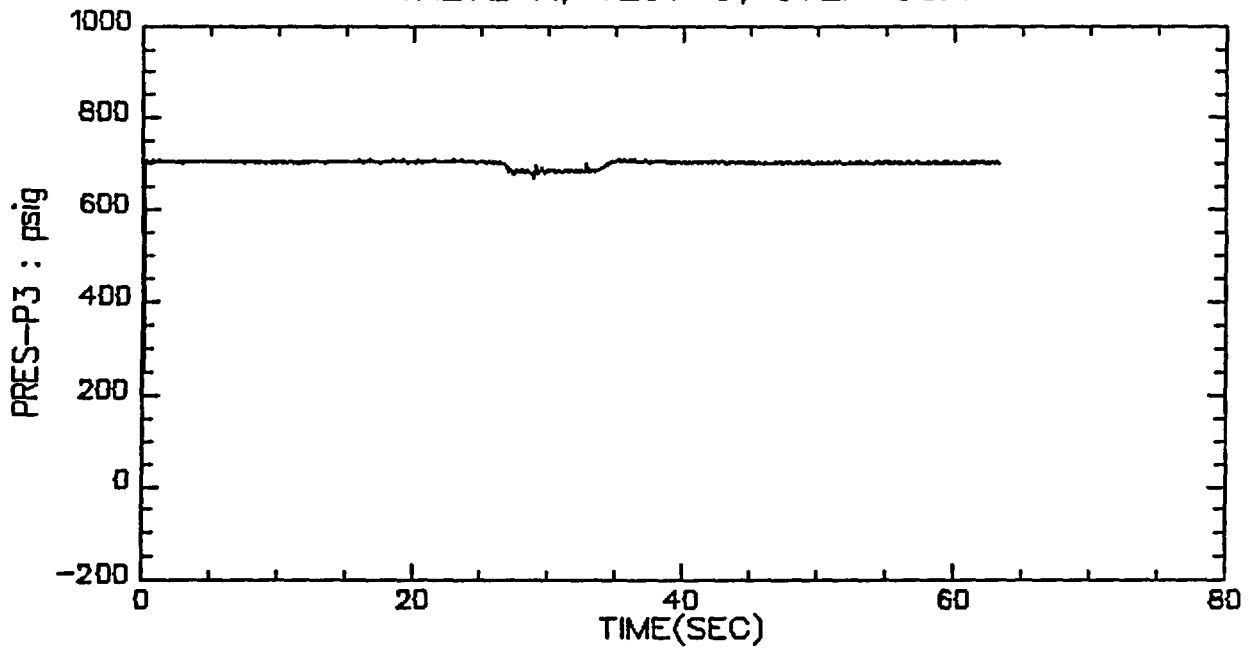

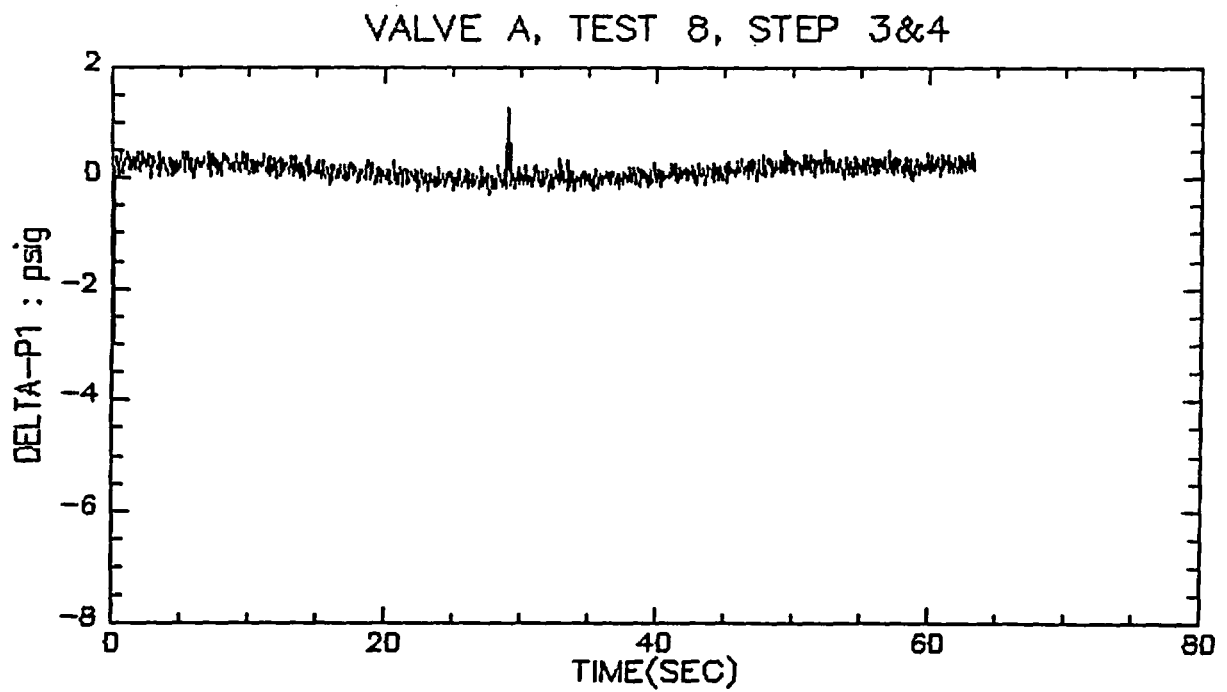
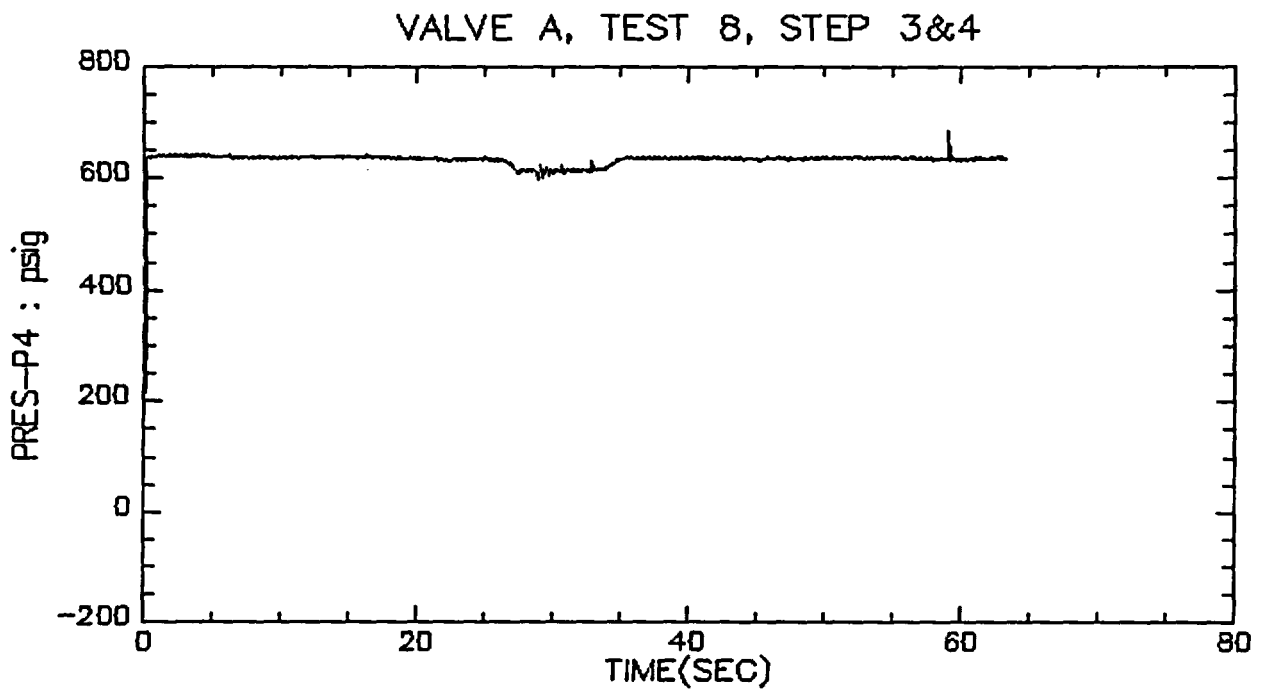

VALVE A, TEST 8, STEP 3&4

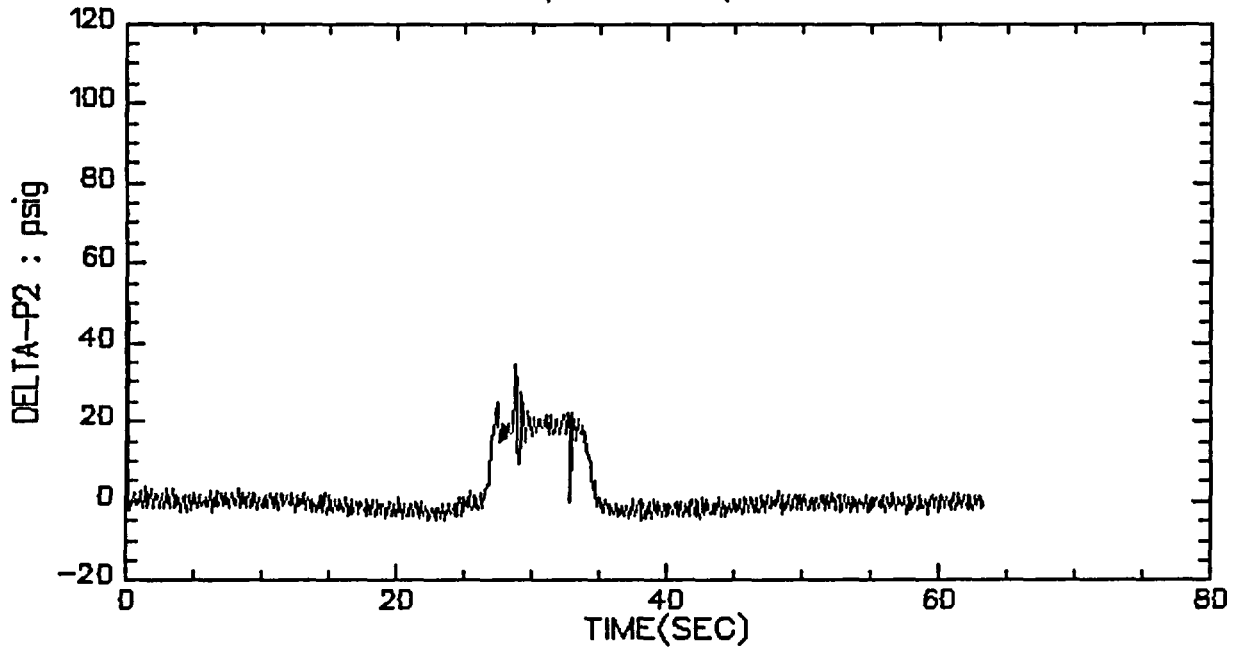

VALVE A, TEST 8, STEP 3&4

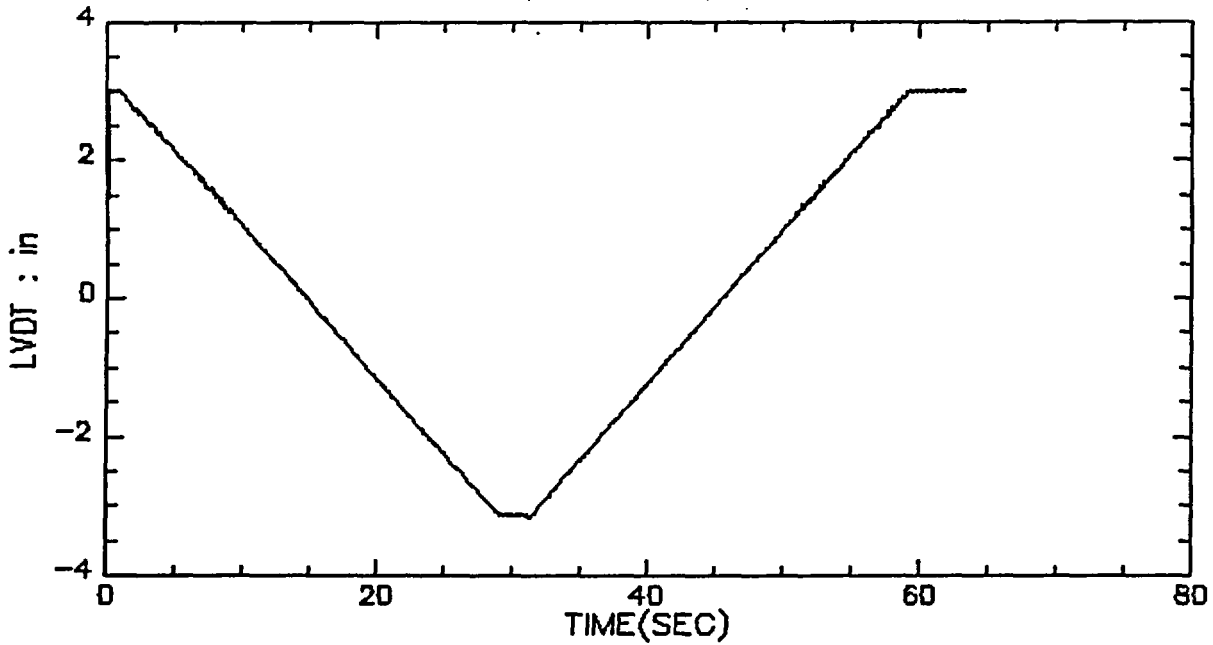

VALVE A, TEST 8, STEP 3&4

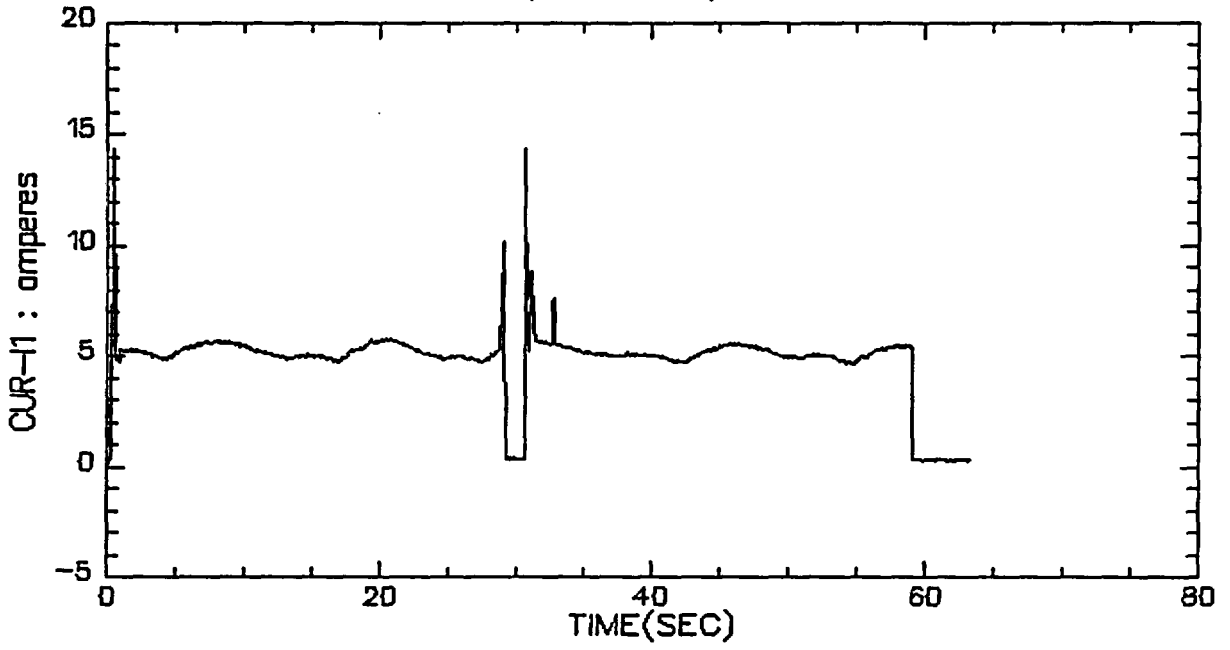

VALVE A, TEST 8, STEP 3&4

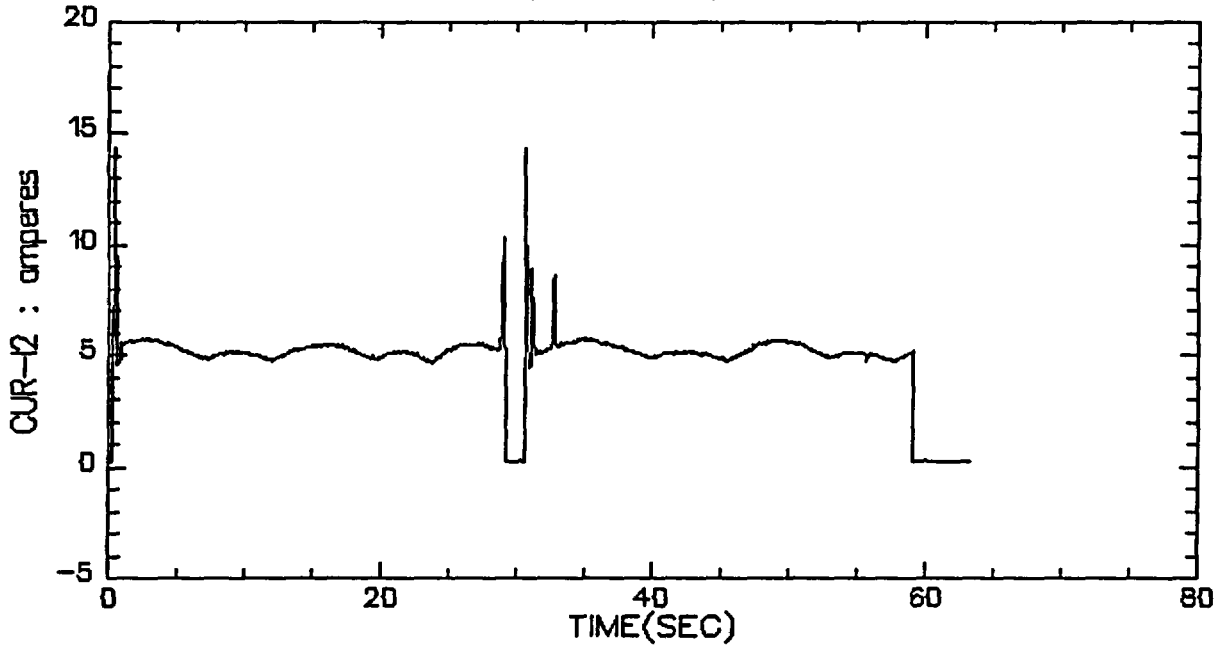

VALVE A, TEST 8, STEP 3&4

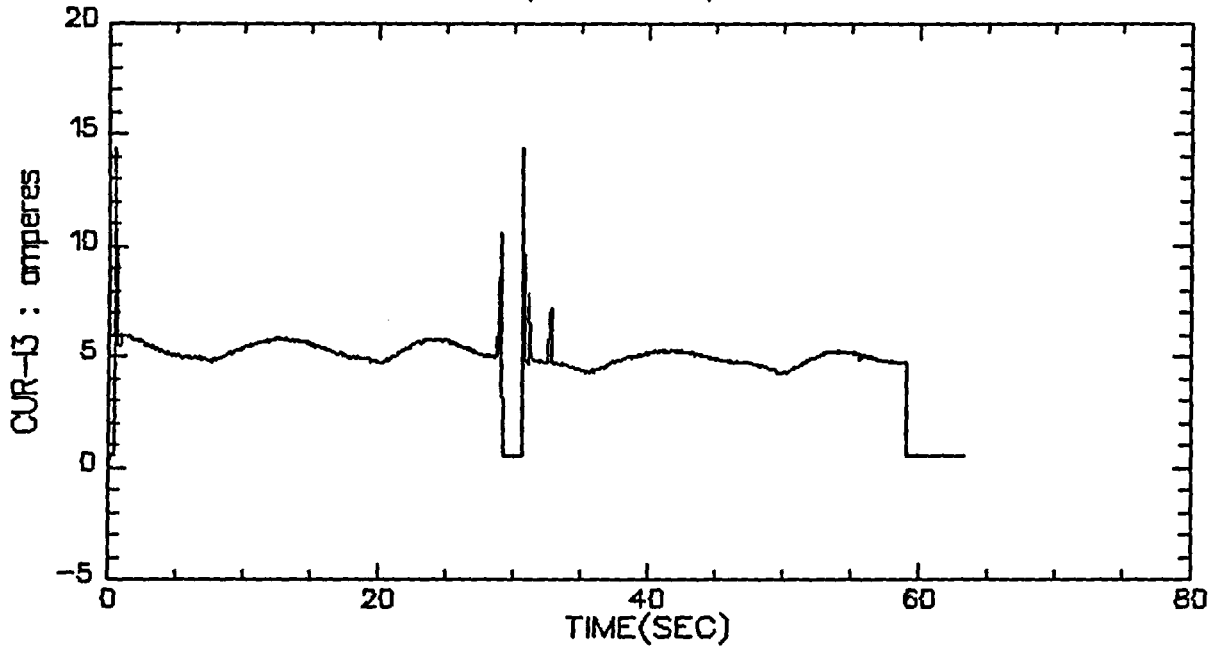

VALVE A, TEST 8, STEP 3&4

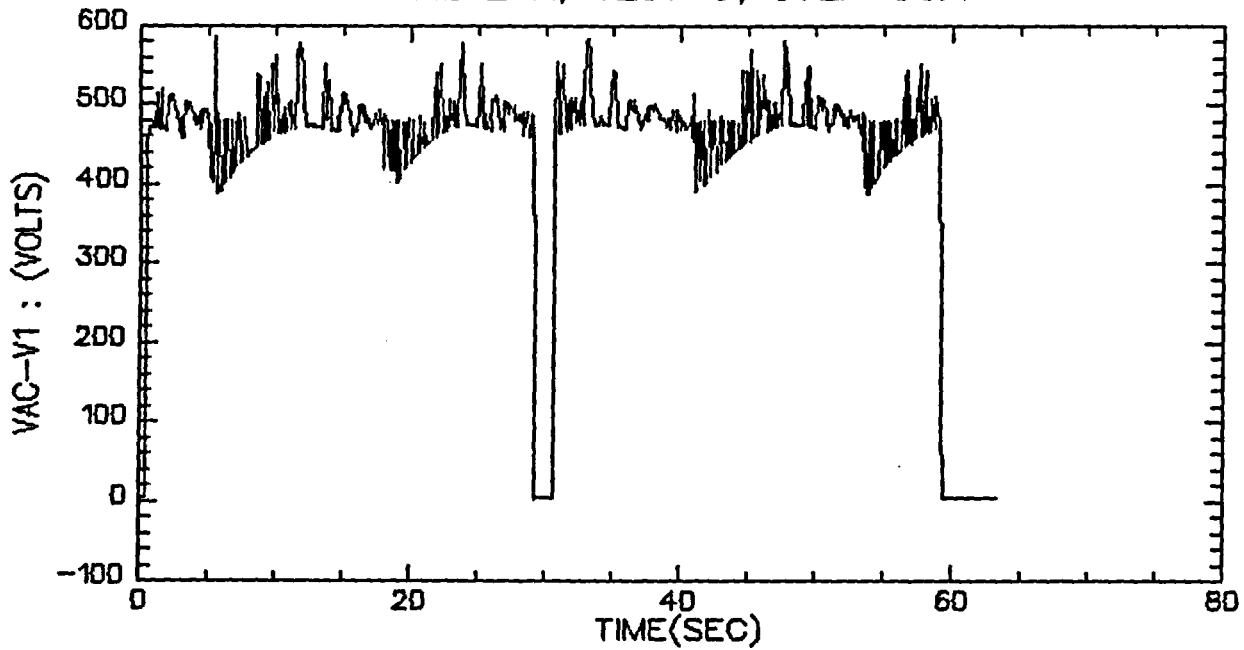

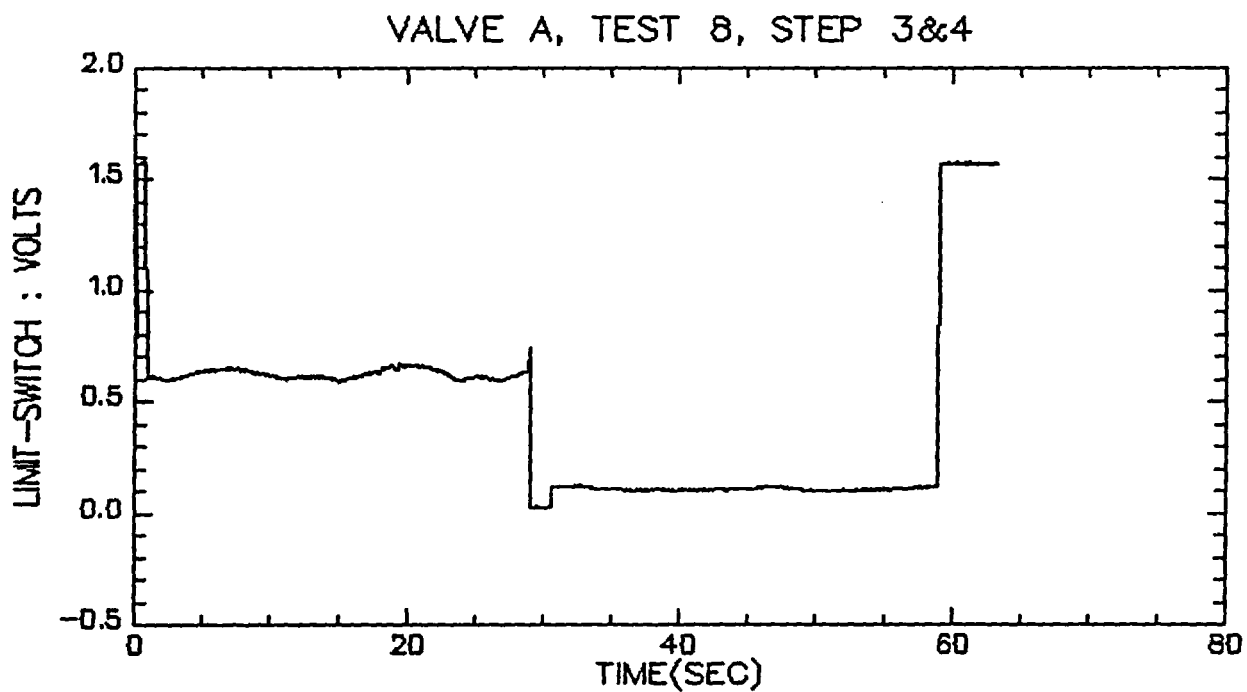
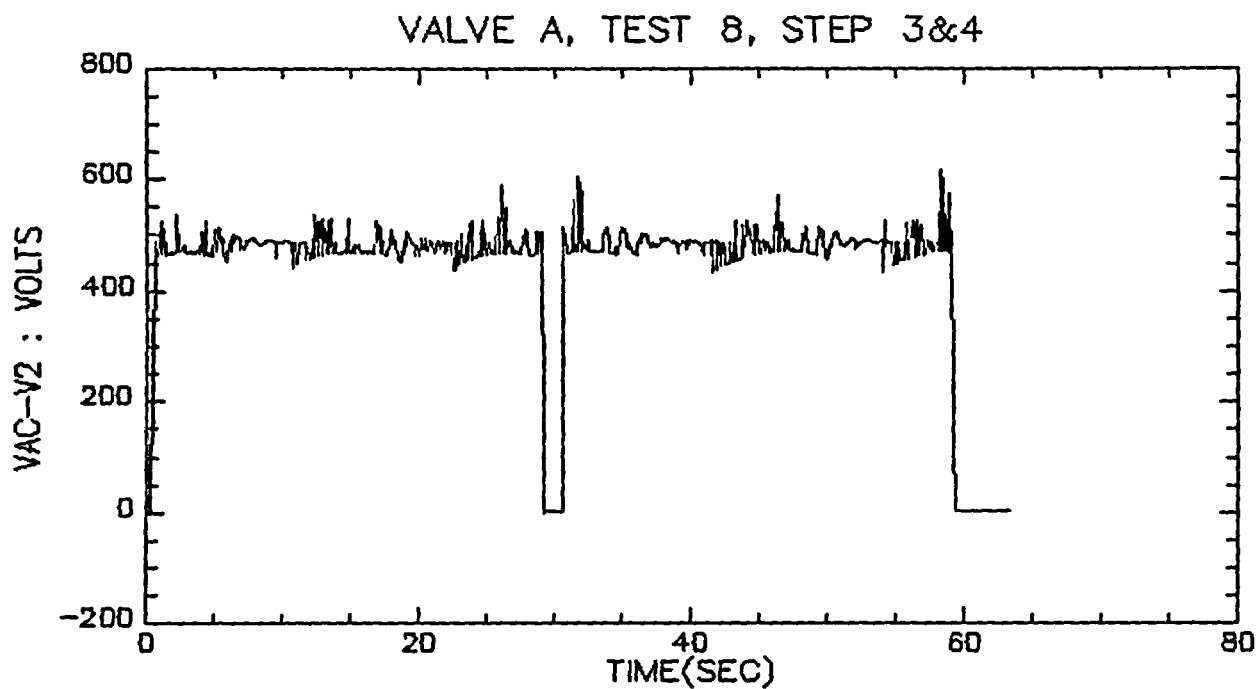

VALVE A, TEST 8, STEP 3&4

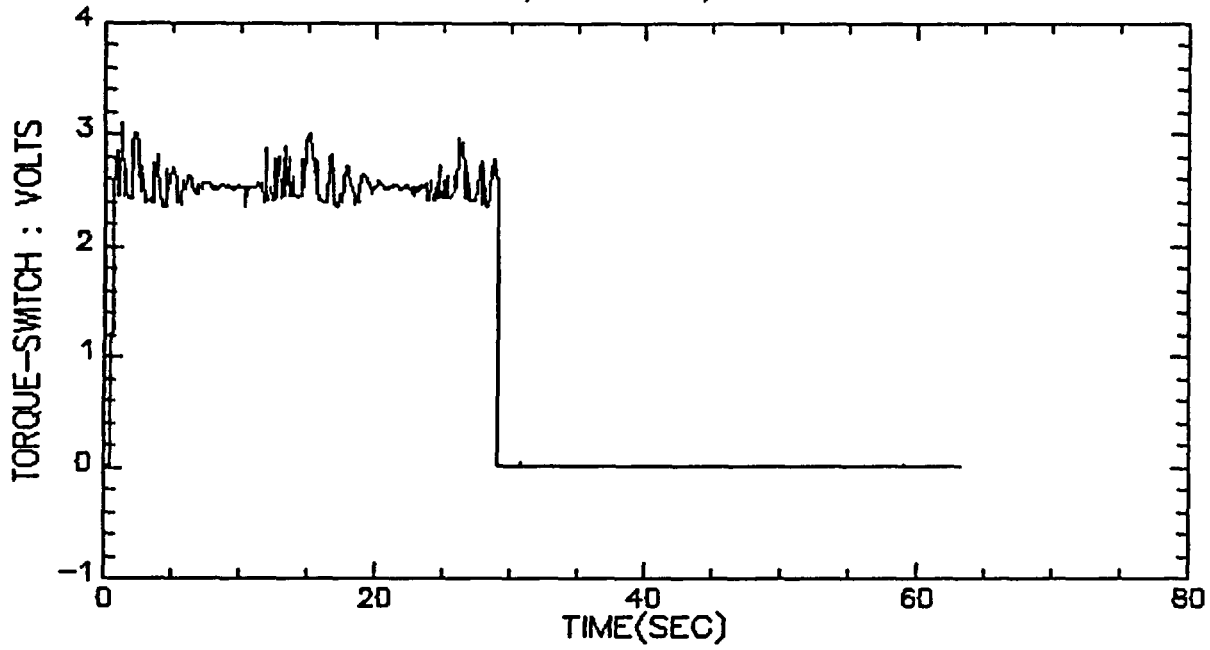

VALVE A, TEST 8, STEP 3&4

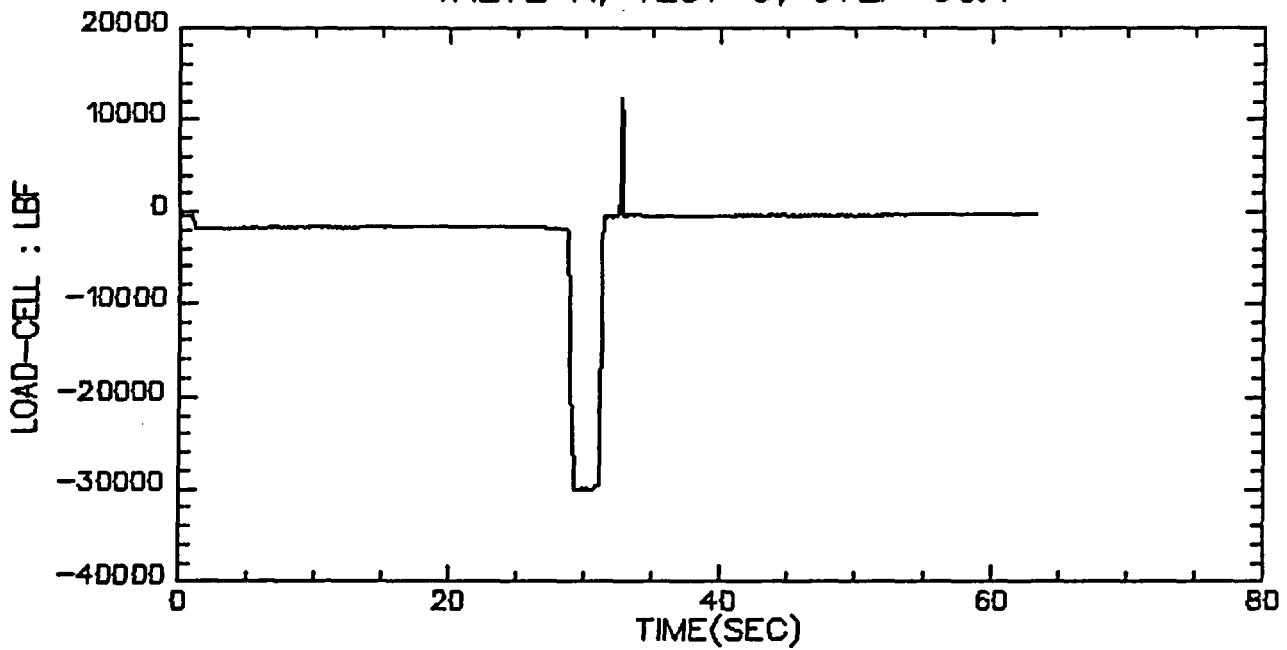

VALVE A, TEST 8, STEP 5

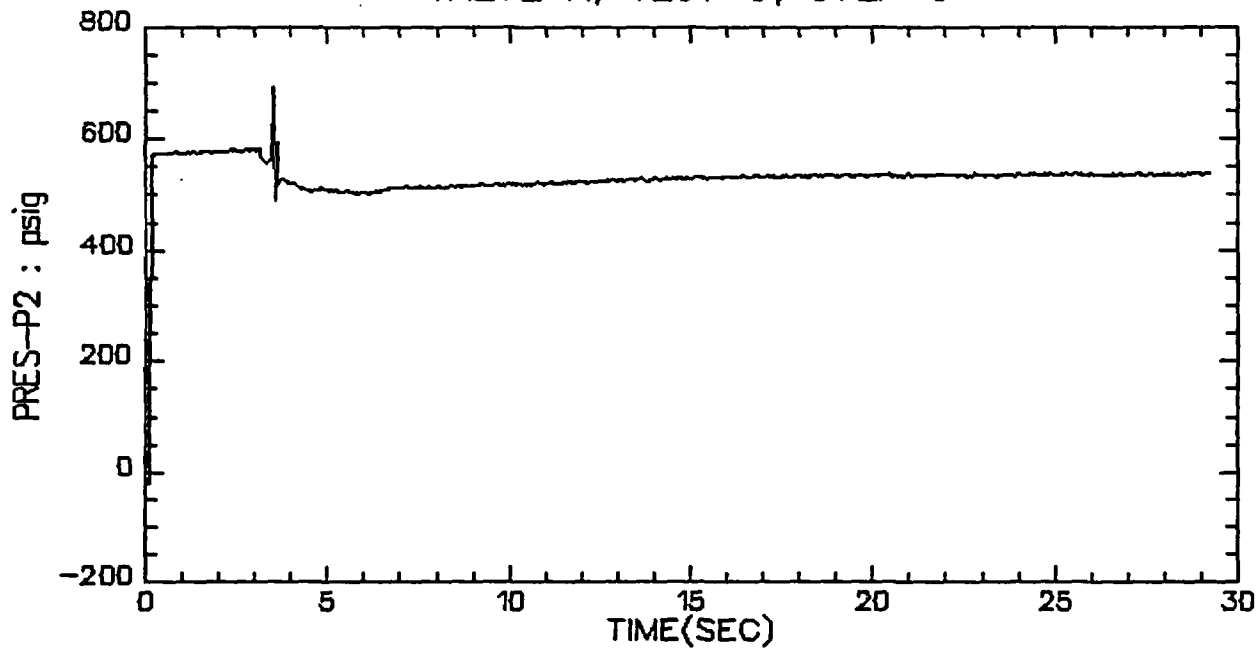

VALVE A, TEST 8, STEP 5

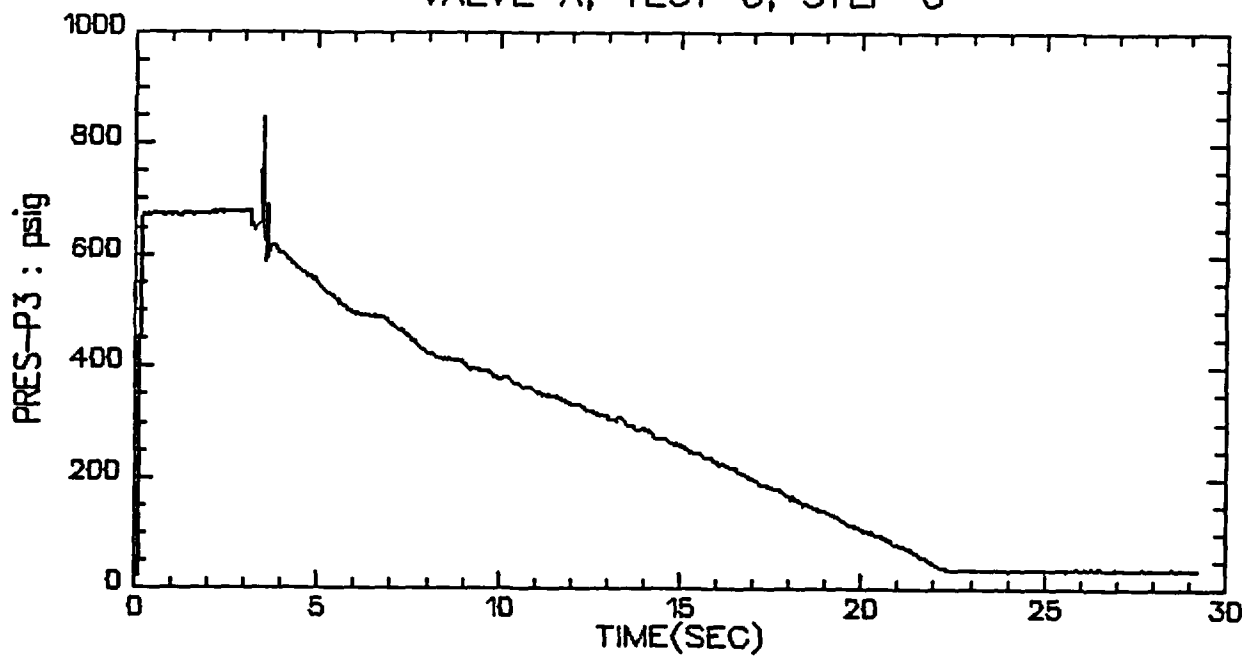

VALVE A, TEST 8, STEP 5

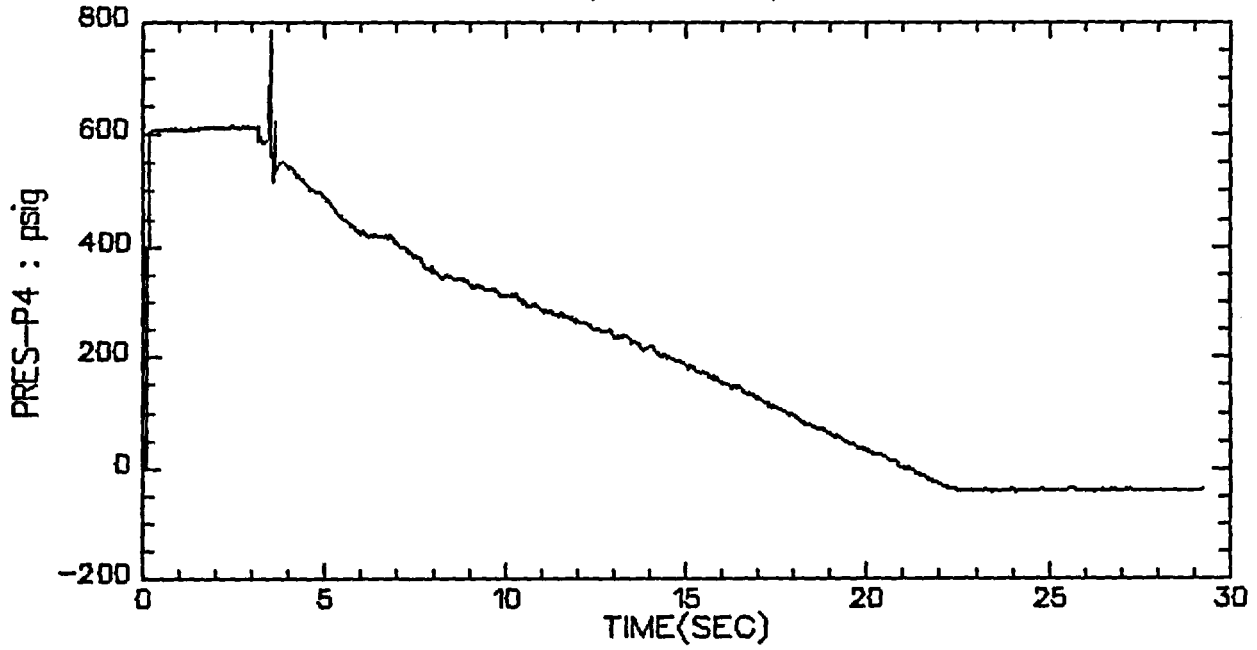

VALVE A, TEST 8, STEP 5

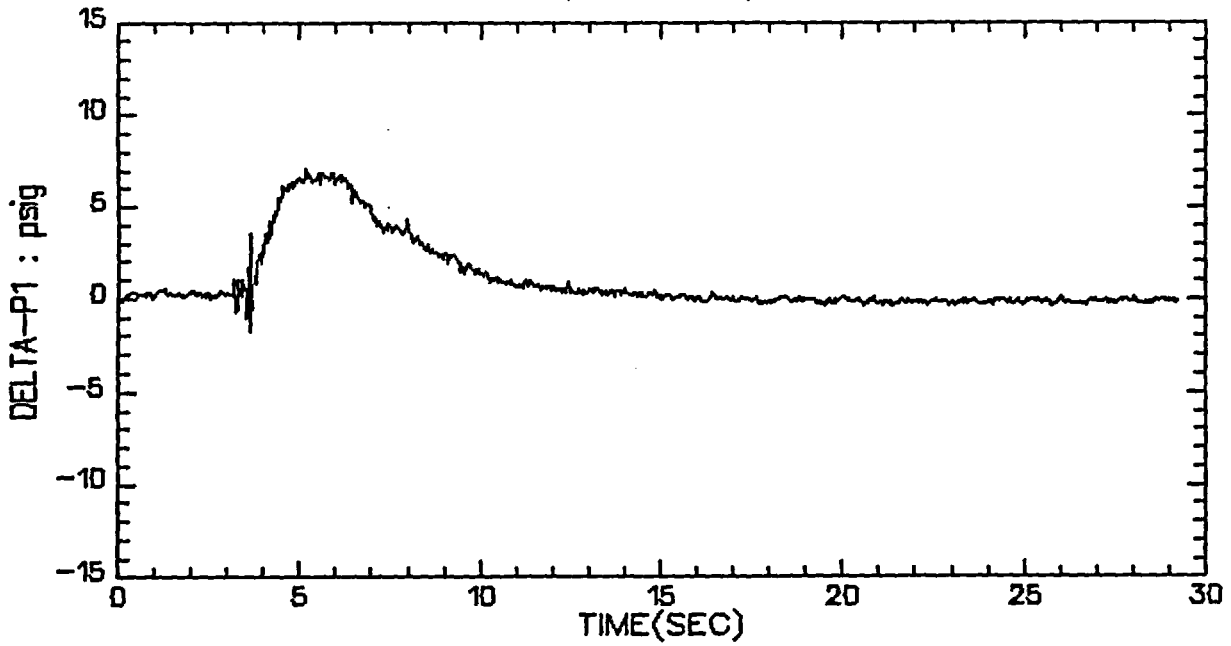

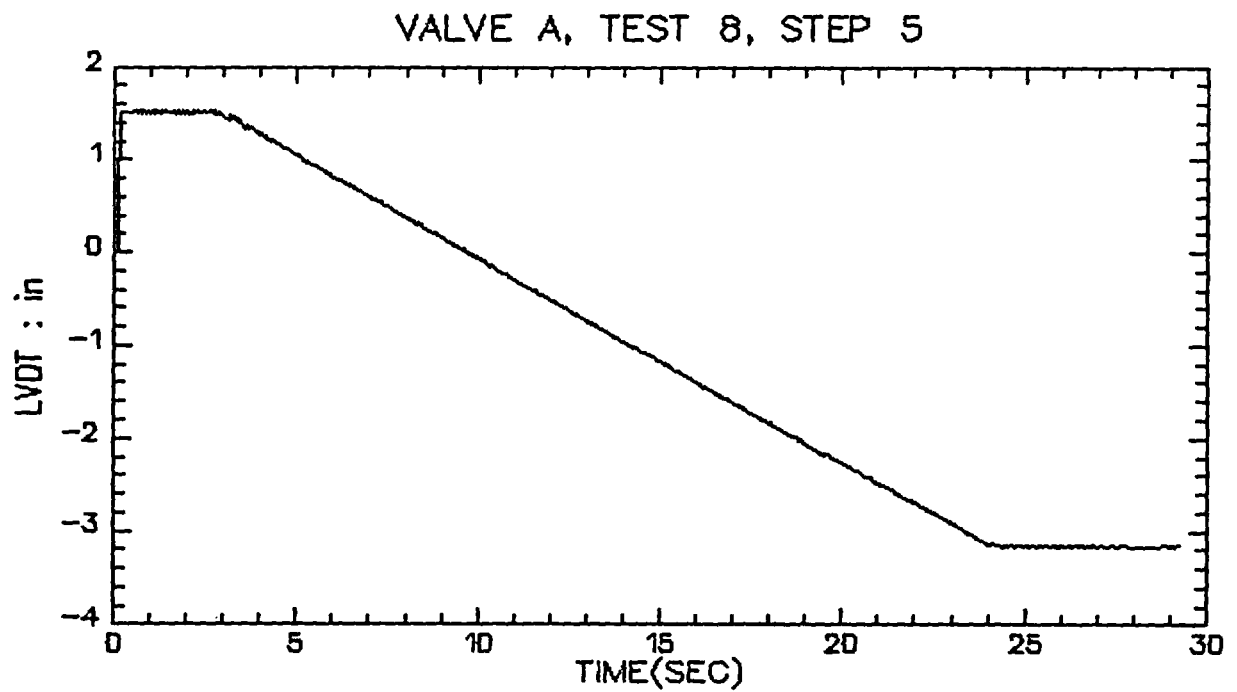
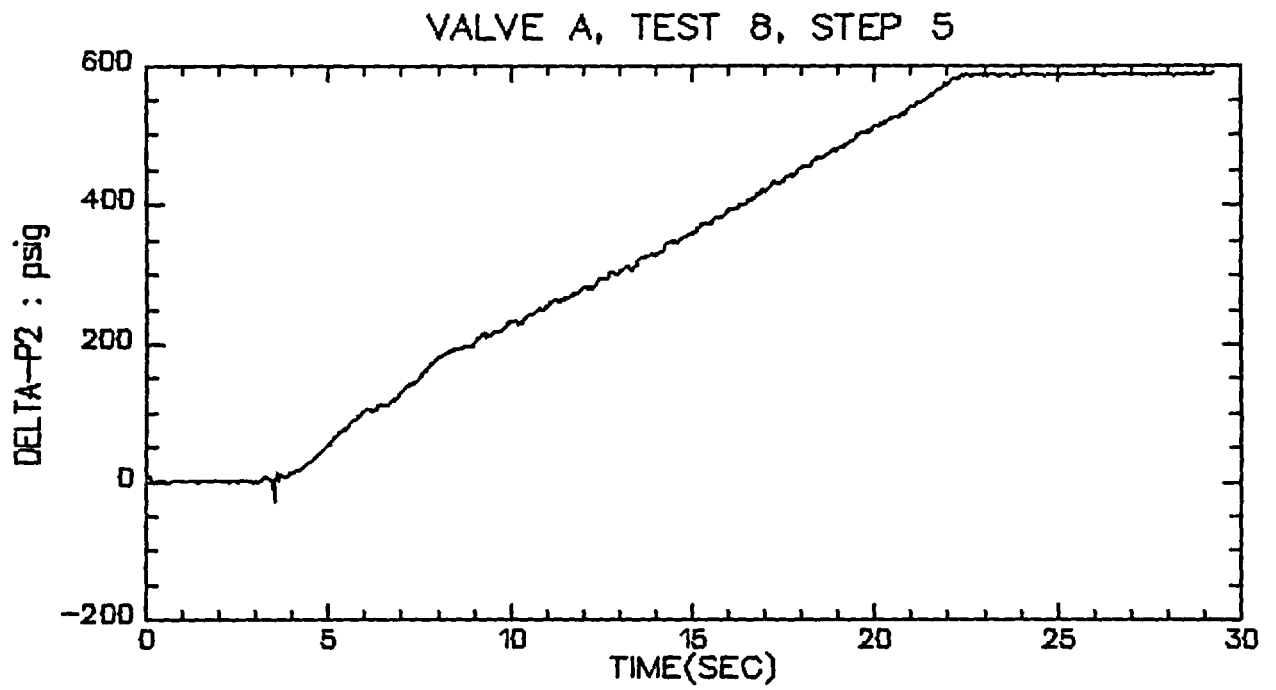

VALVE A, TEST 8, STEP 5

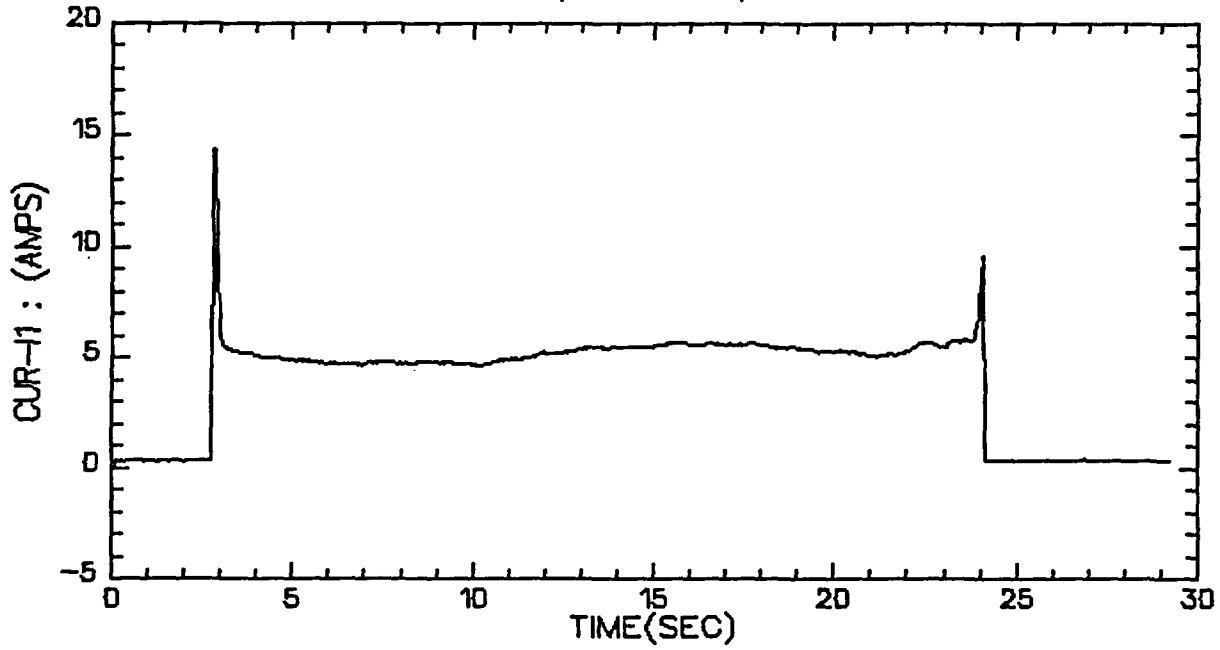

VALVE A, TEST 8, STEP 5

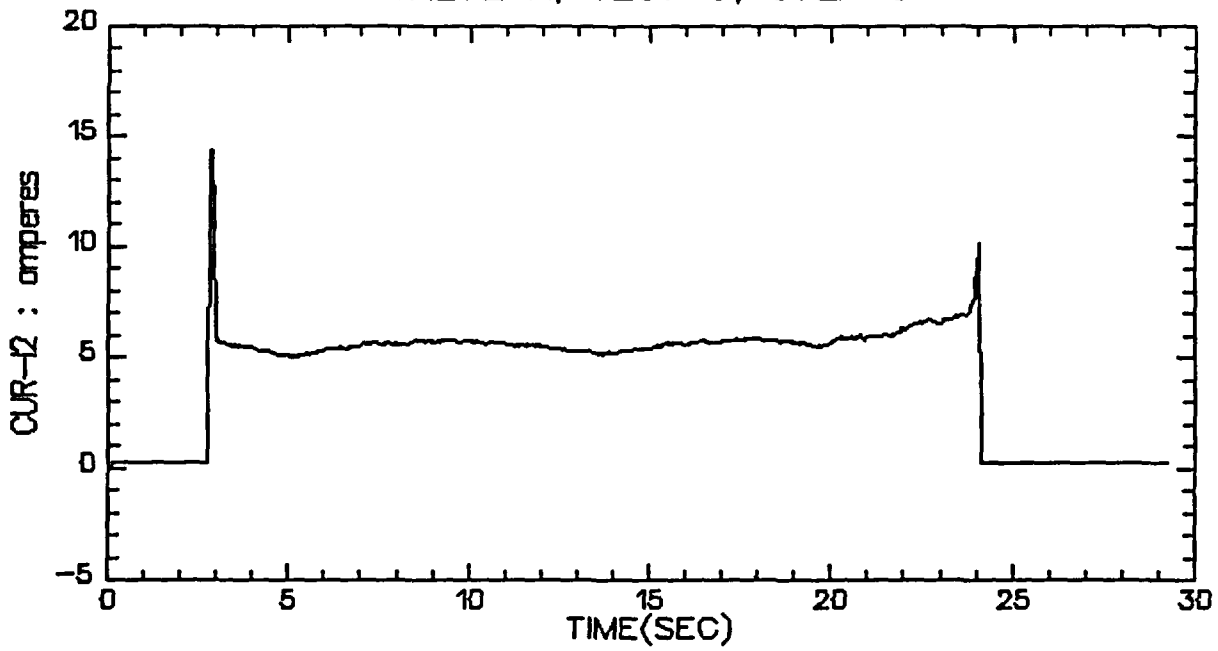

VALVE A, TEST 8, STEP 5

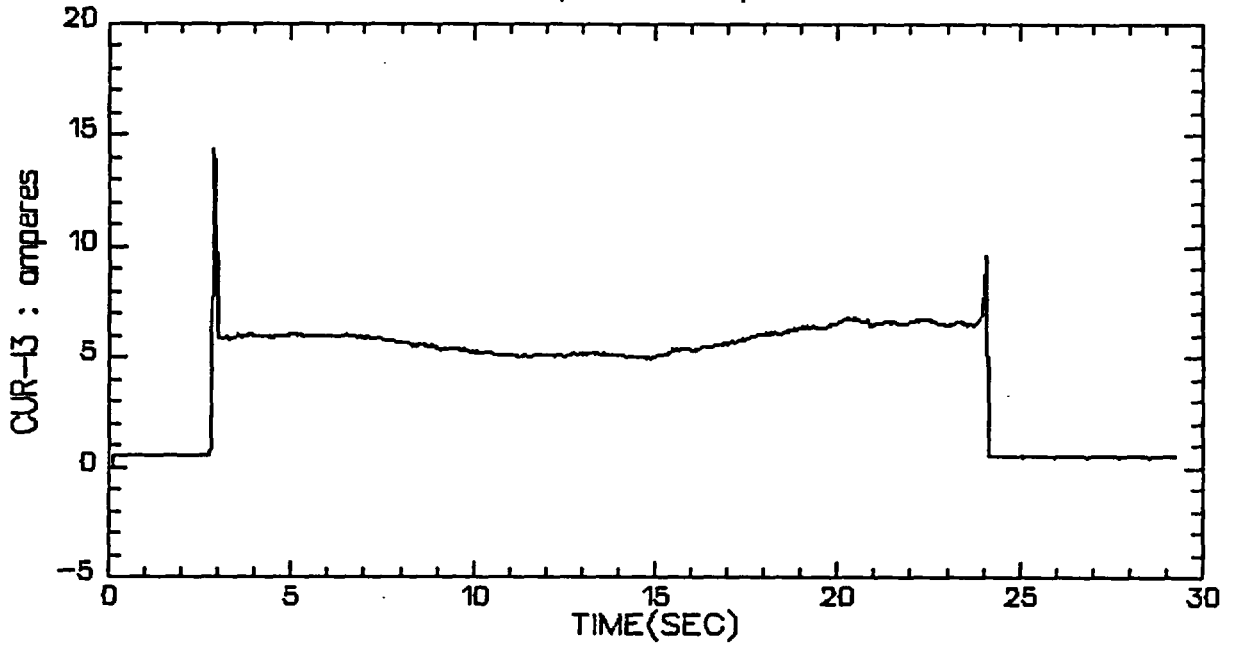

VALVE A, TEST 8, STEP 5

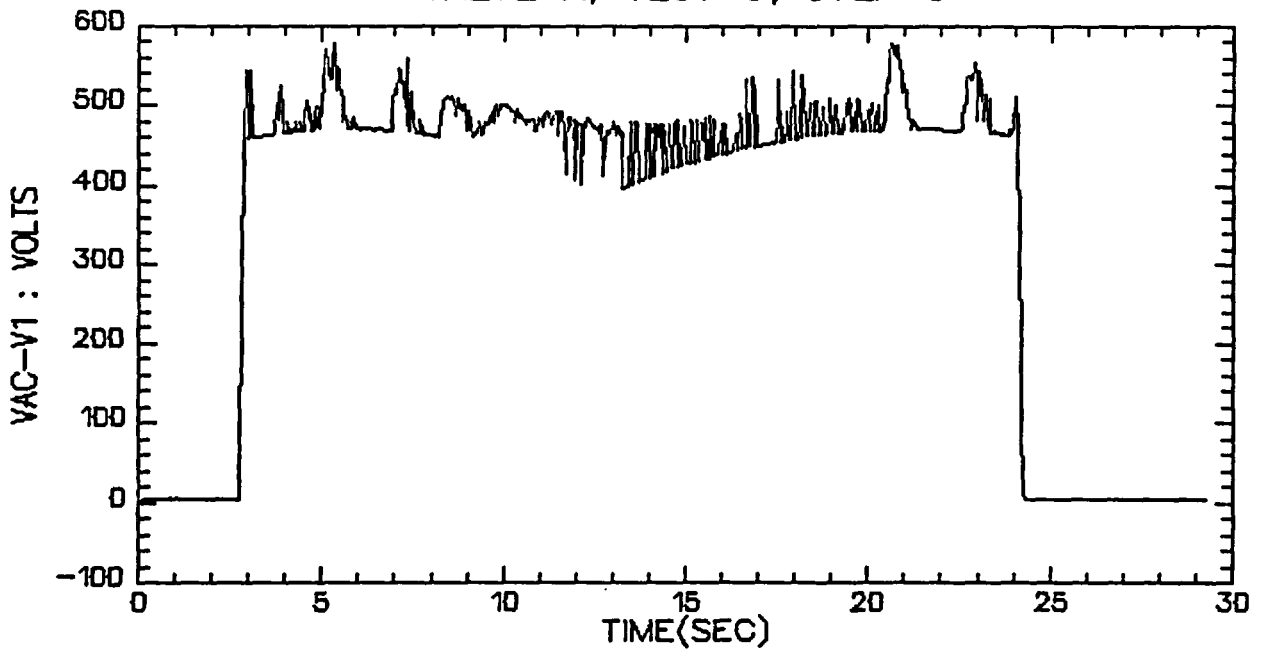

VALVE A, TEST 8, STEP 5

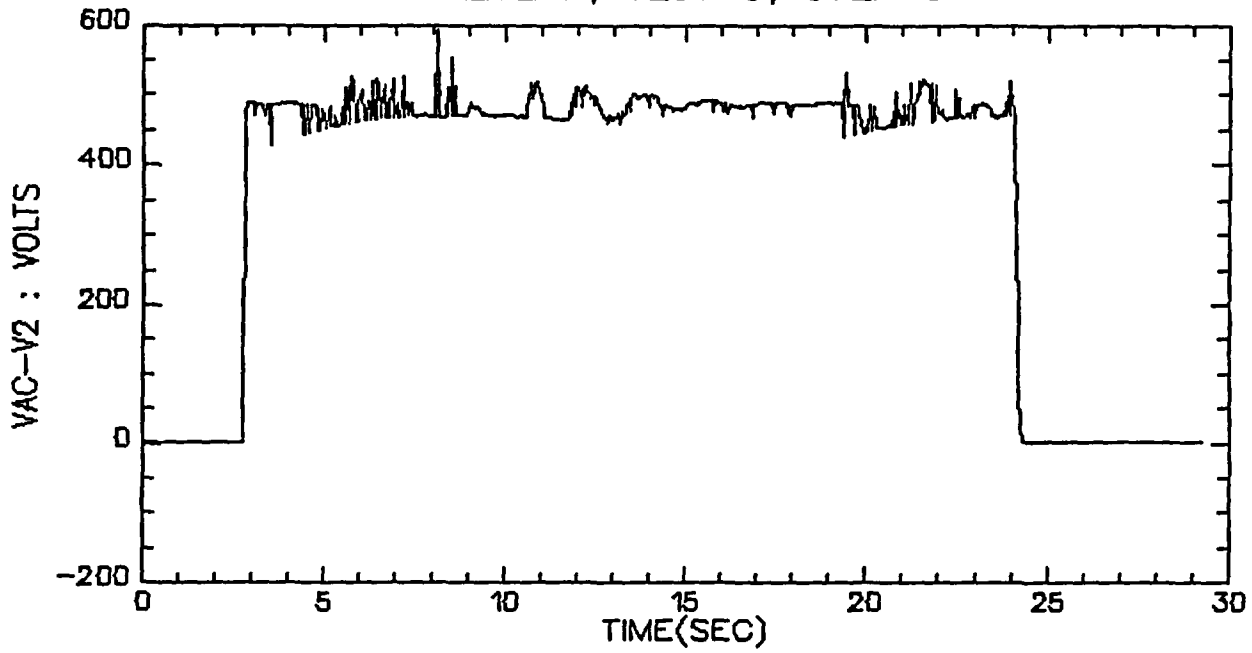

VALVE A, TEST 8, STEP 5

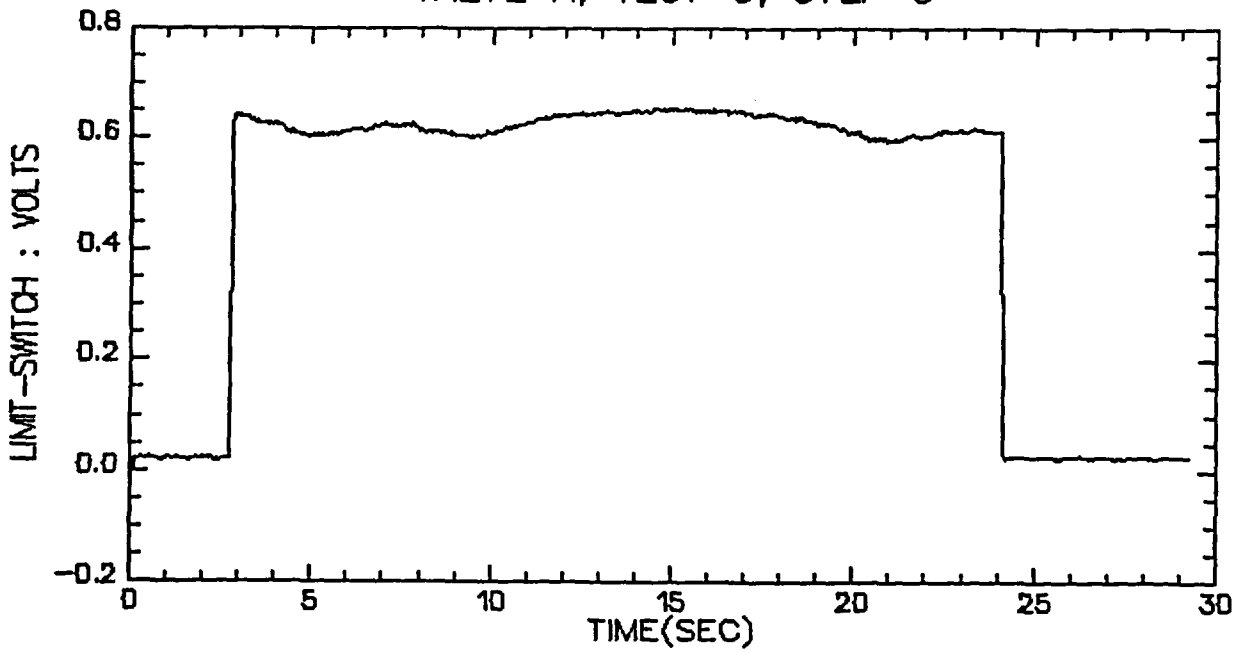

VALVE A, TEST 8, STEP 5

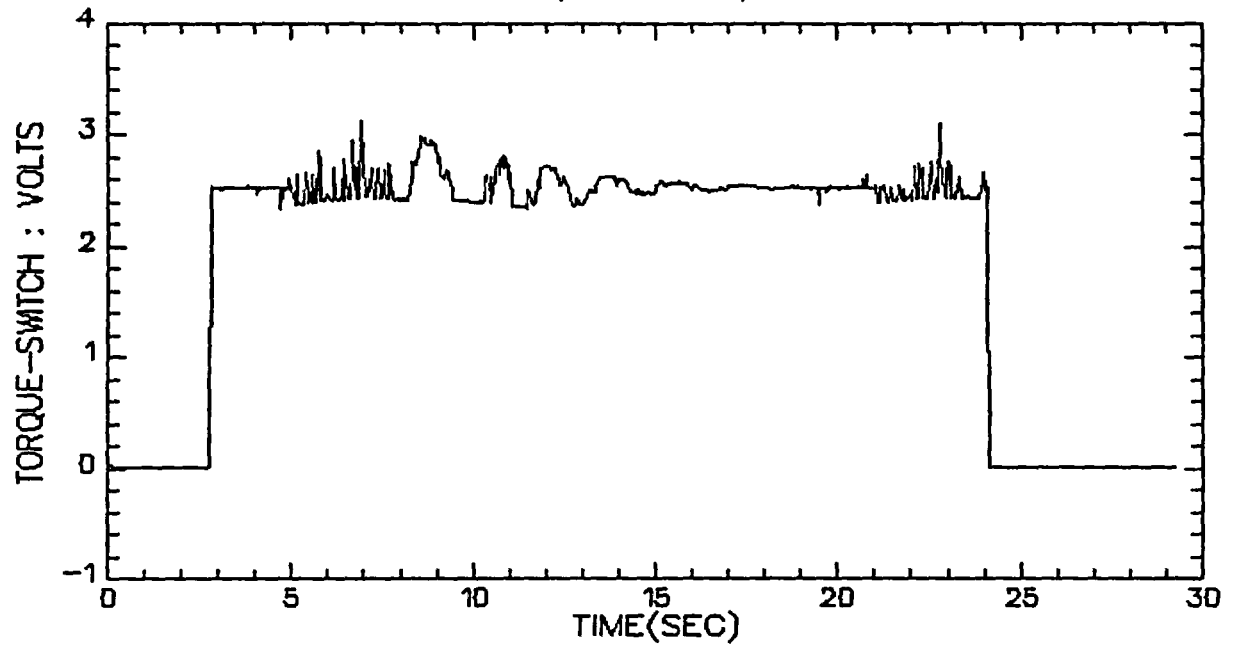

VALVE A, TEST 8, STEP 5

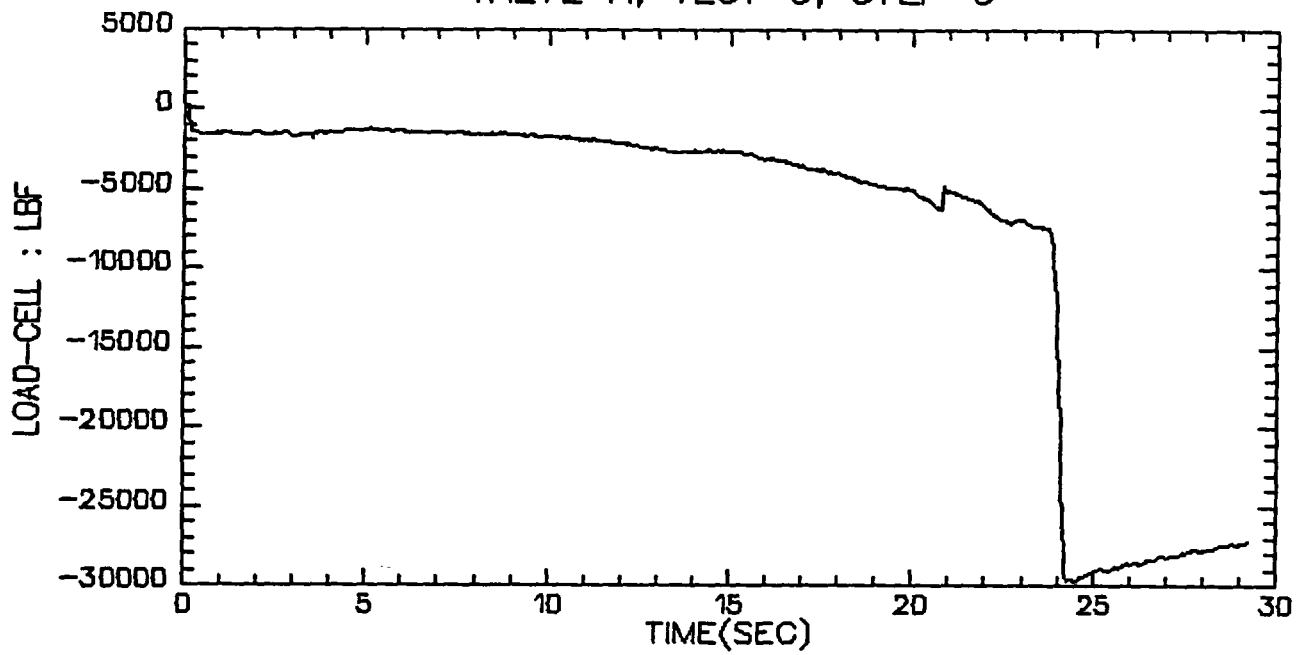

VALVE A, TEST 8 STEP 6&7

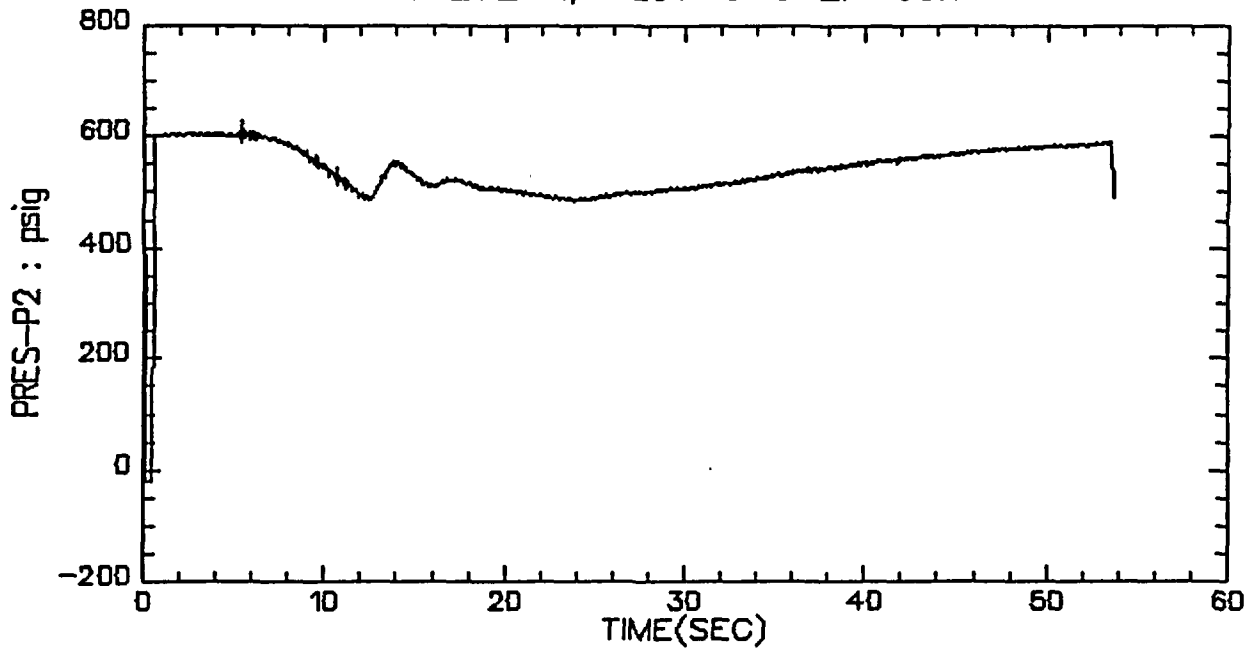

VALVE A, TEST 8, STEP 6&7

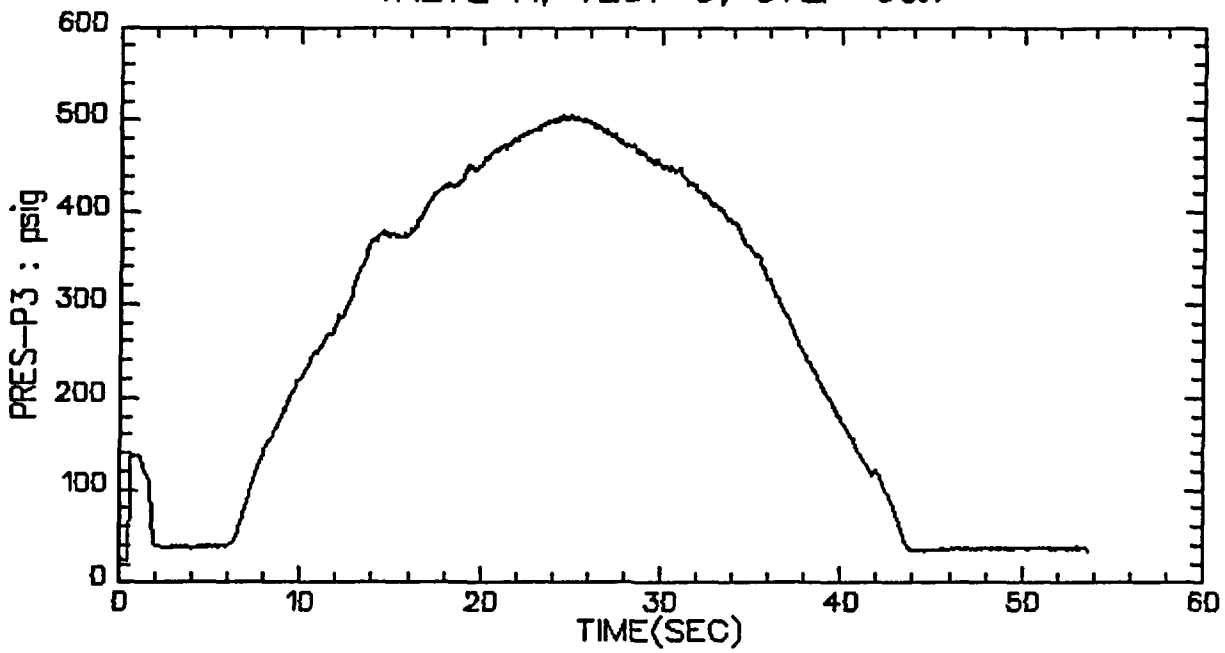

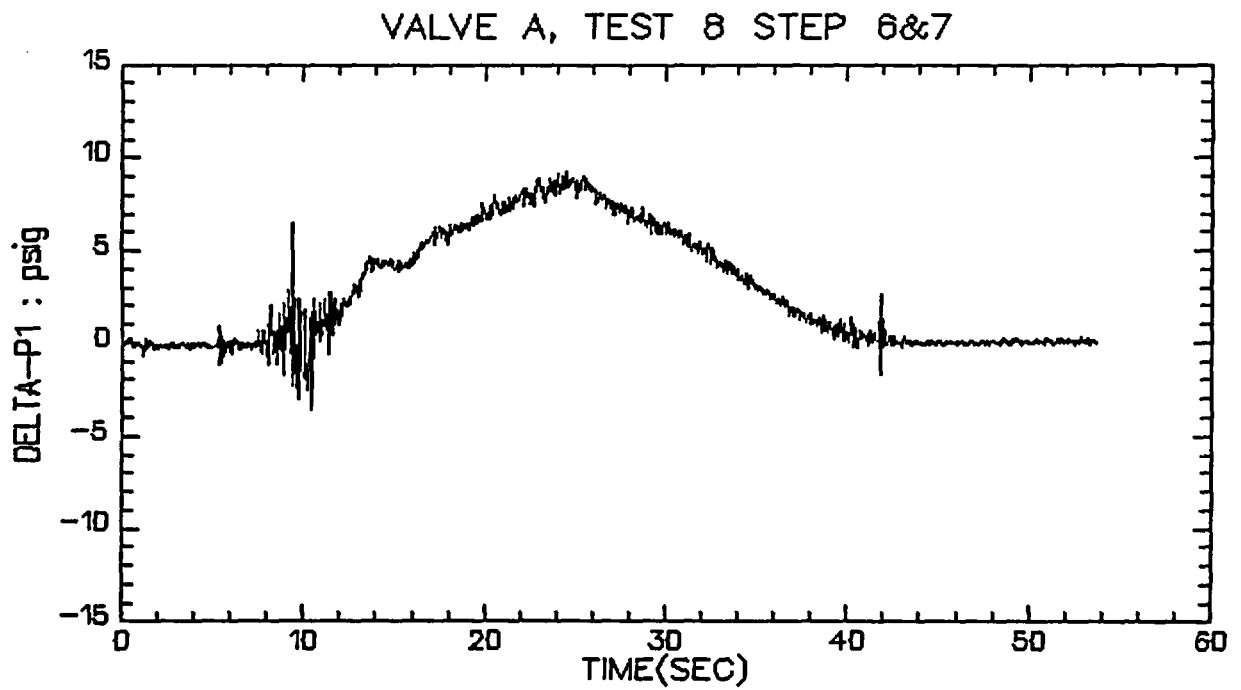
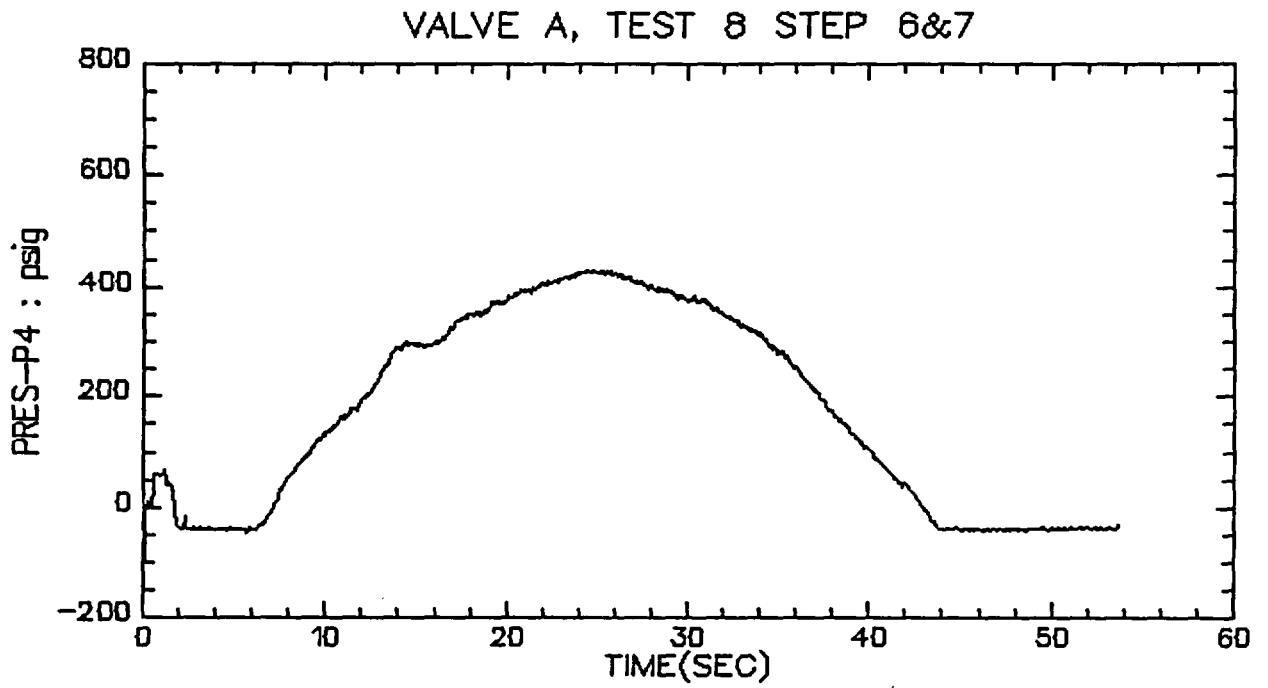

VALVE A, TEST 8 STEP 6&7

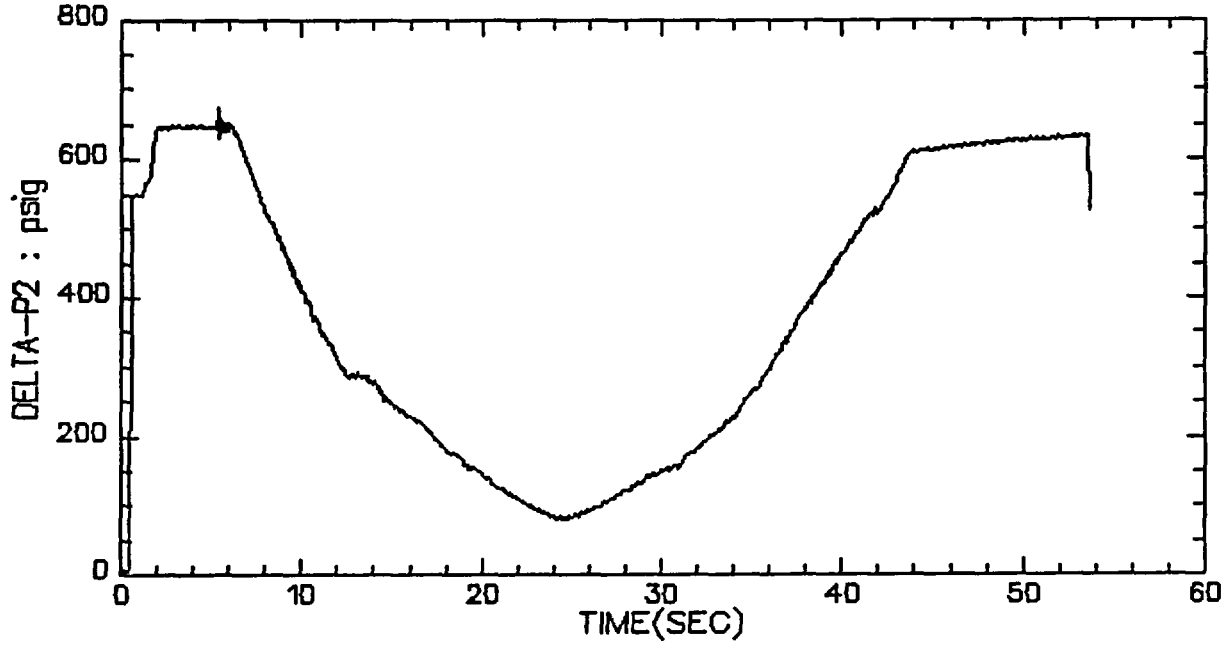

VALVE A, TEST 8 STEP 6&7

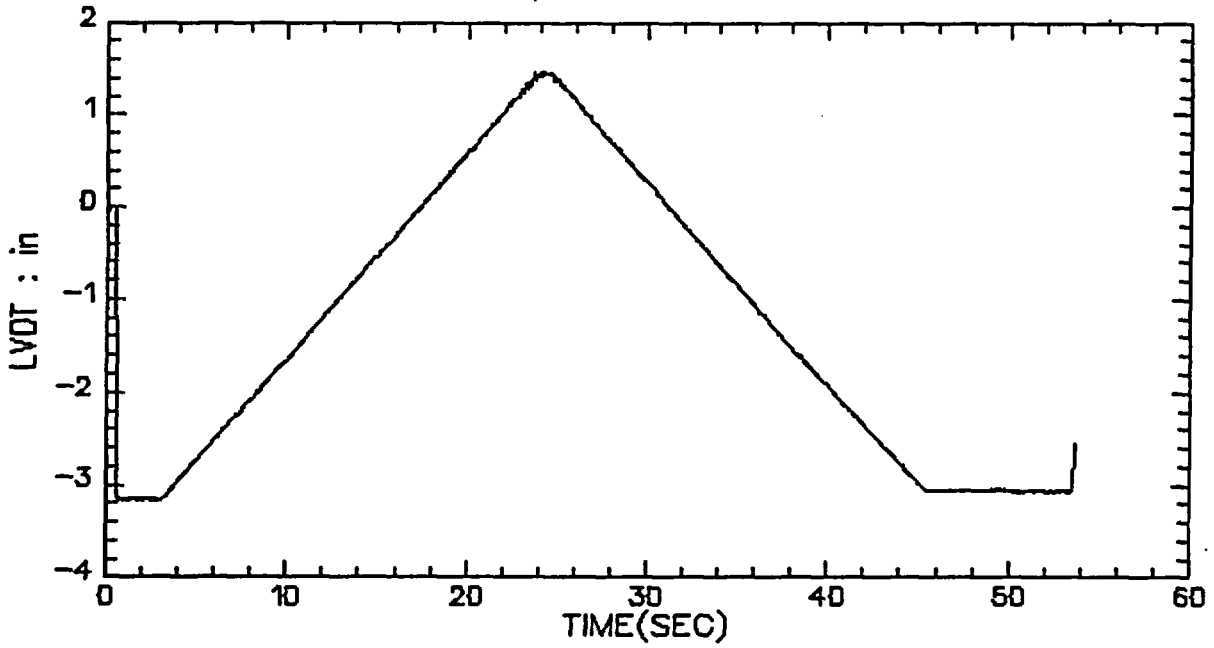

VALVE A, TEST 8 STEP 6&7

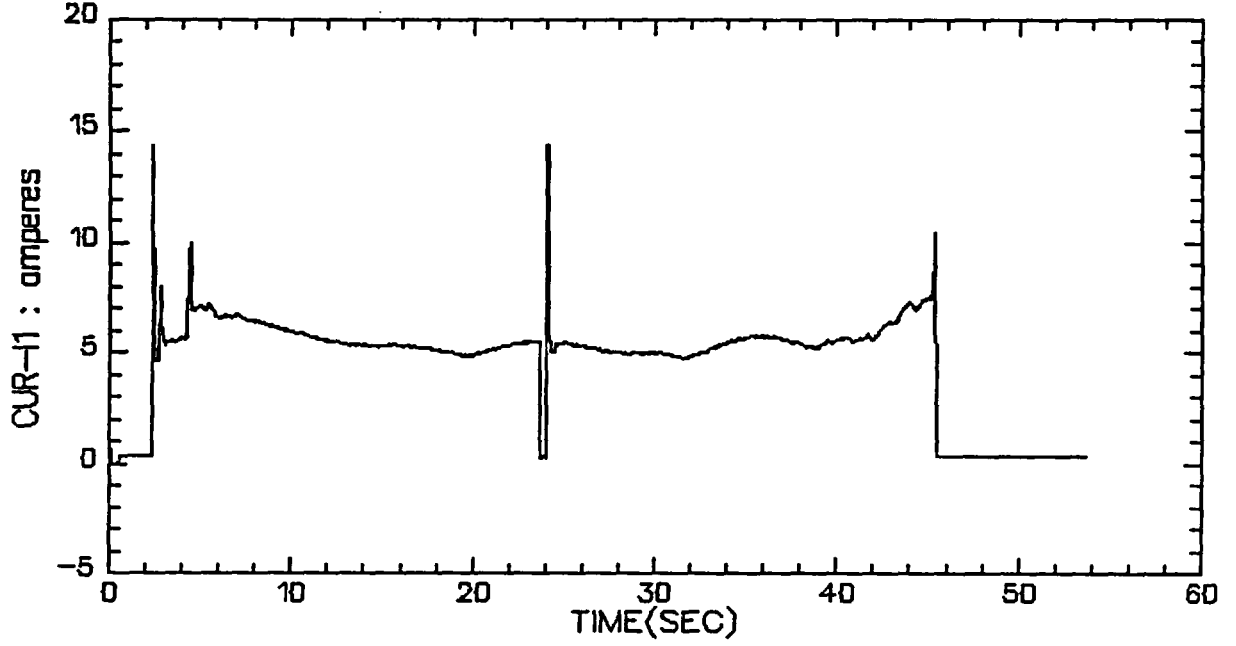

VALVE A, TEST 8 STEP 6&7

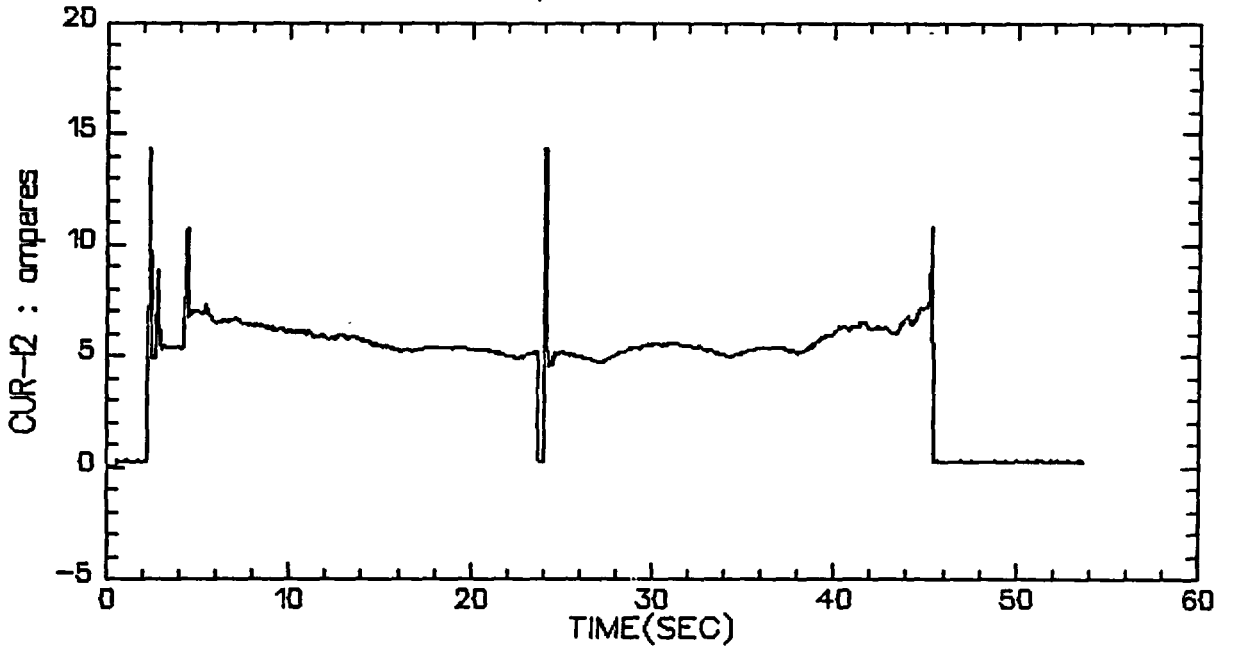

VALVE A, TEST 8 STEP 6&7

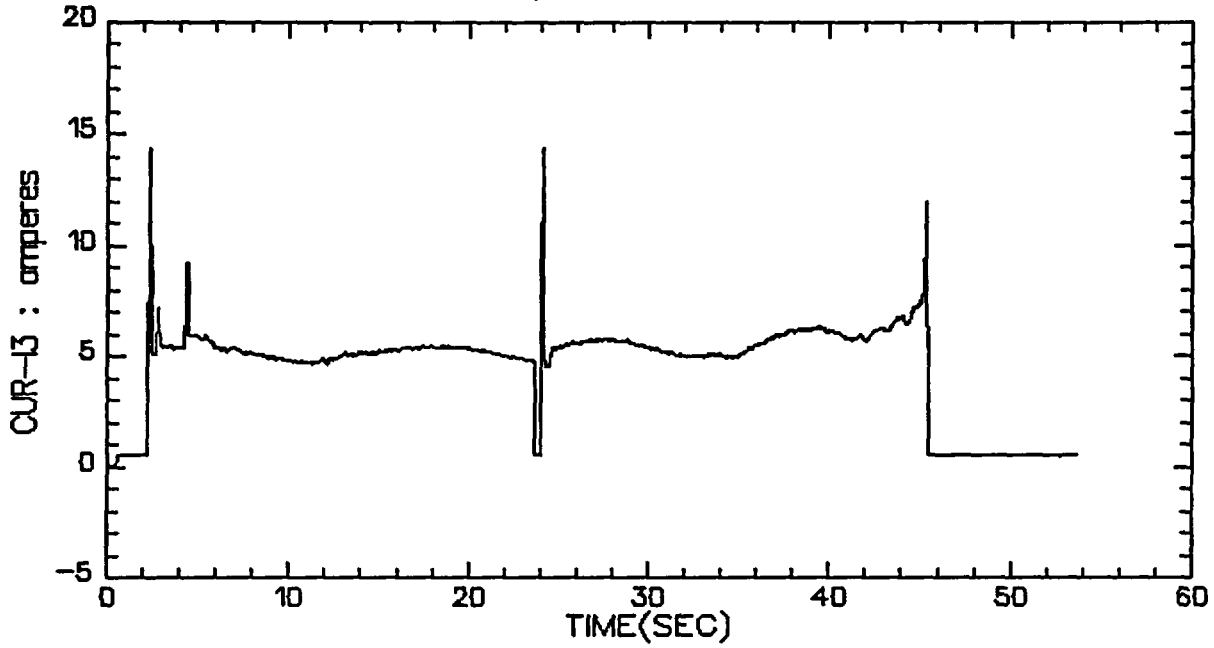

VALVE A, TEST 8 STEP 6&7

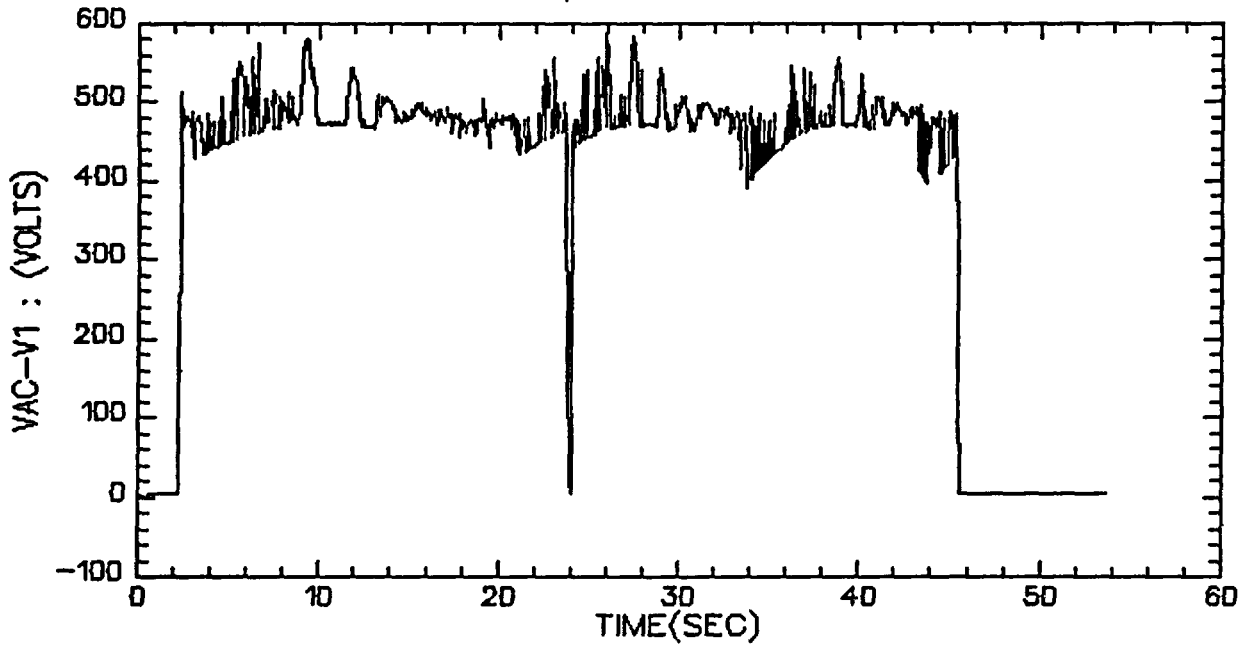

VALVE A, TEST 8 STEP 6&7

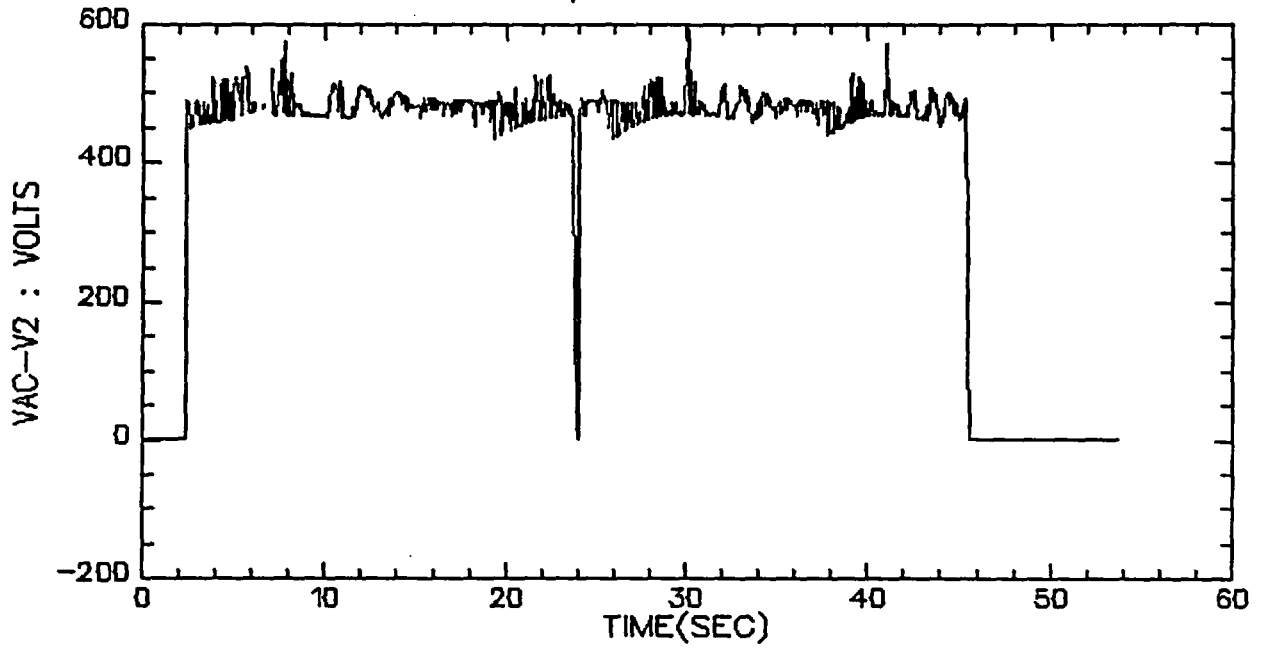

VALVE A, TEST 8 STEP 6&7

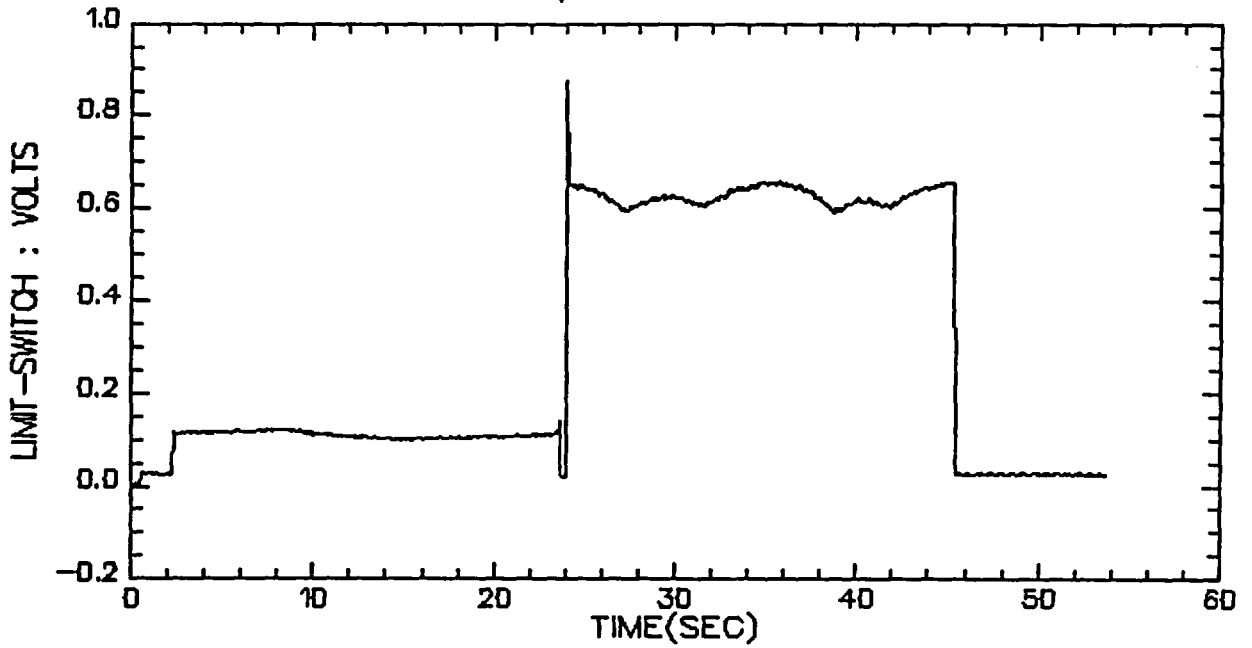

VALVE A, TEST 8 STEP 6&7

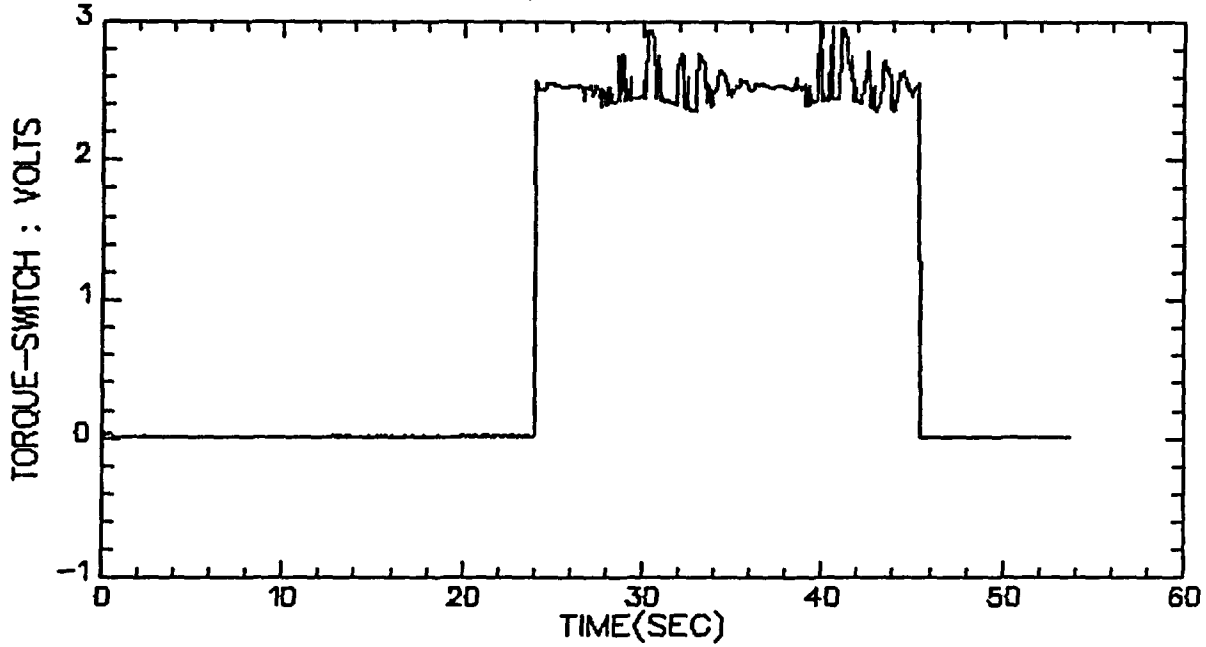

VALVE A, TEST 8 STEP 6&7

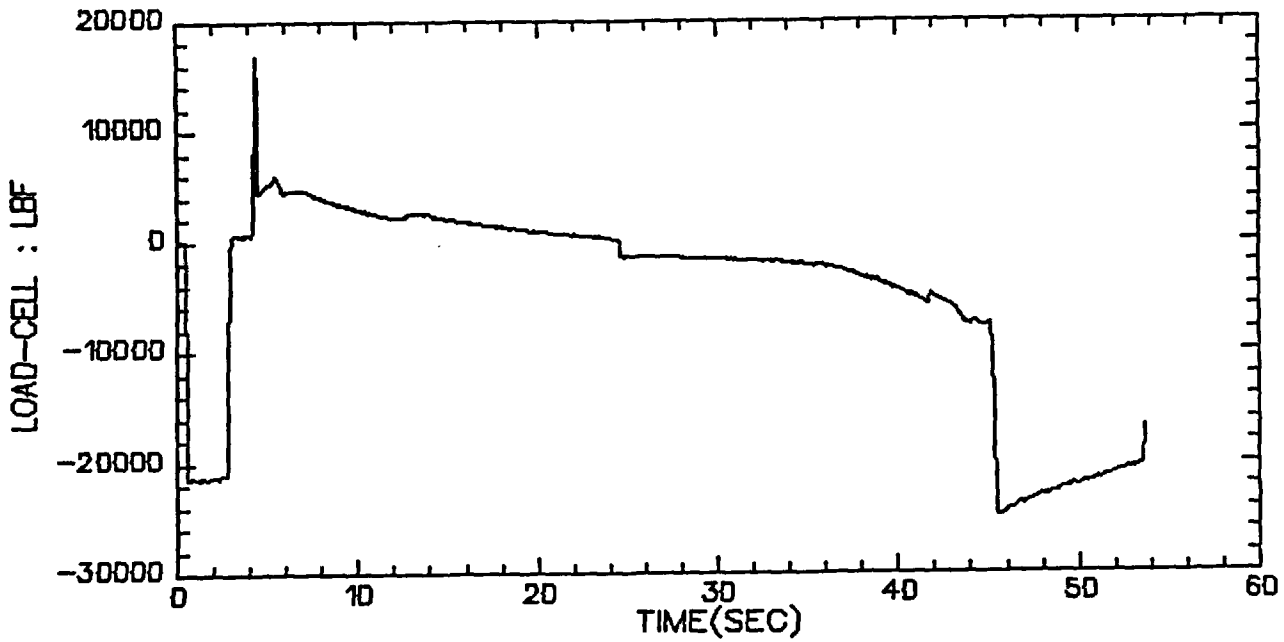

VALVE A, TEST 8, STEP 8&9

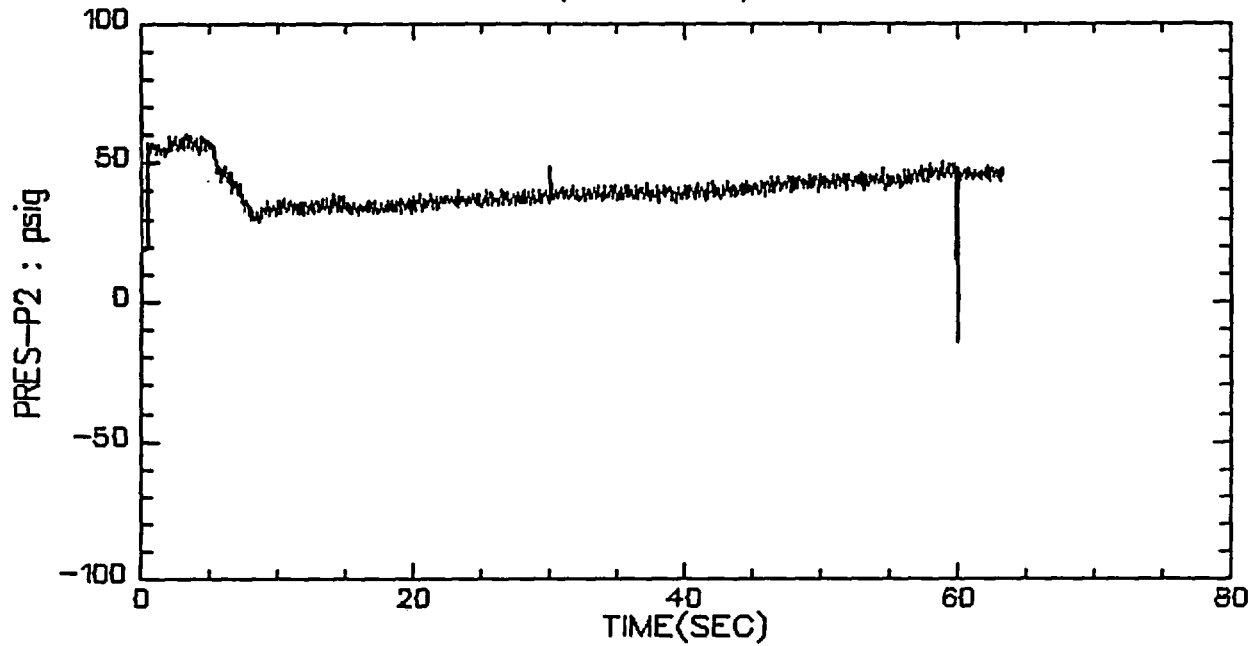

VALVE A, TEST 8, STEP 8&9

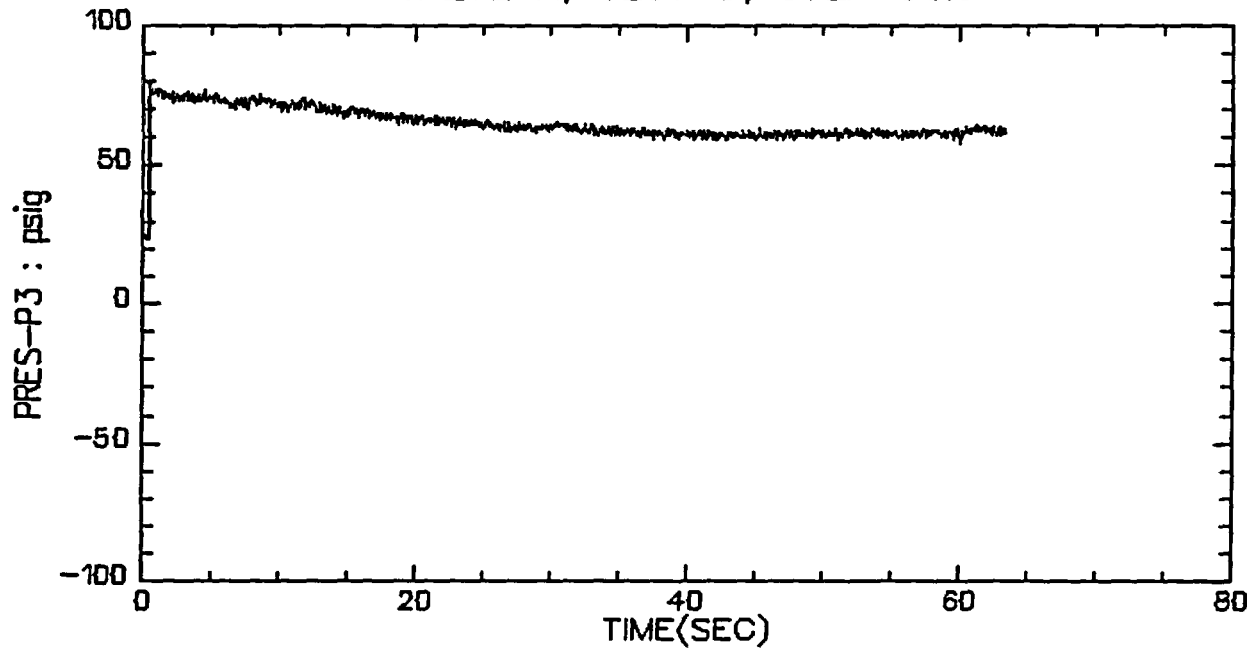

VALVE A, TEST 8, STEP 8&9

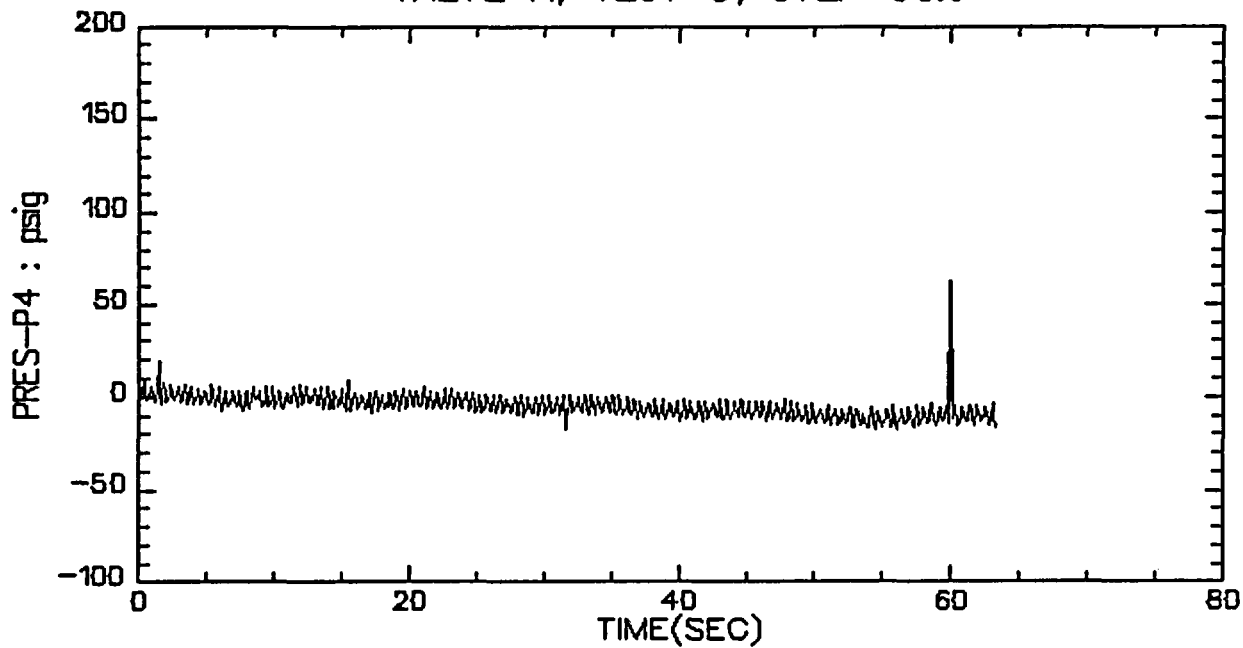

VALVE A, TEST 8, STEP 8&9

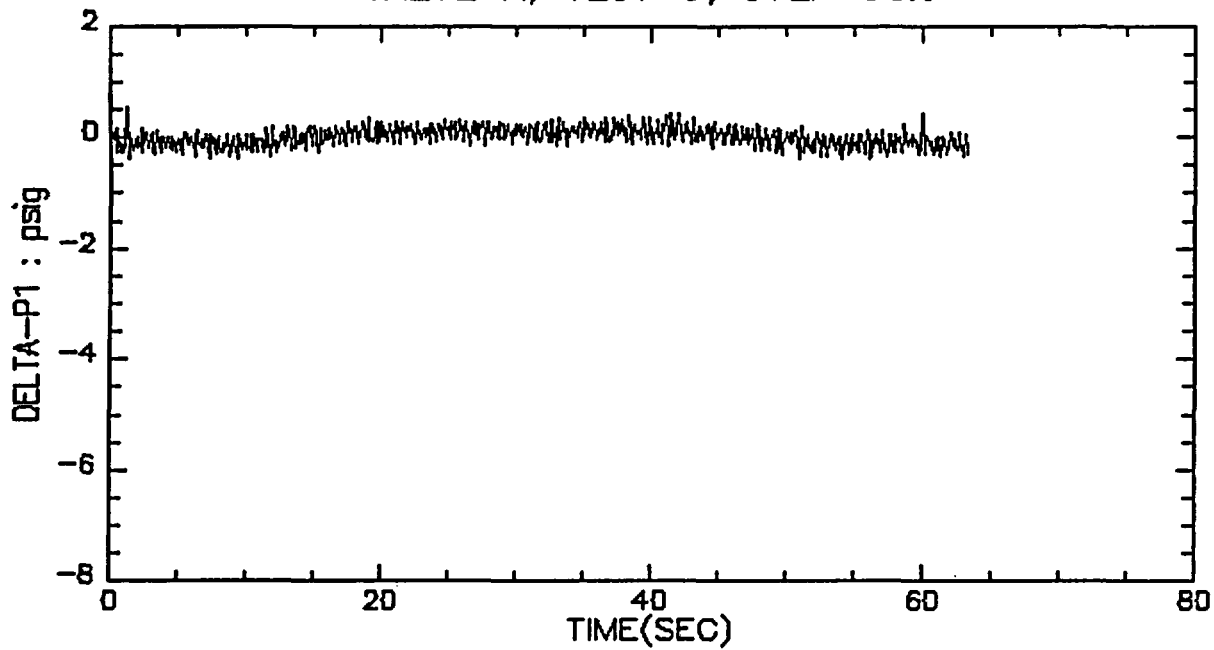

VALVE A, TEST 8, STEP 8&9

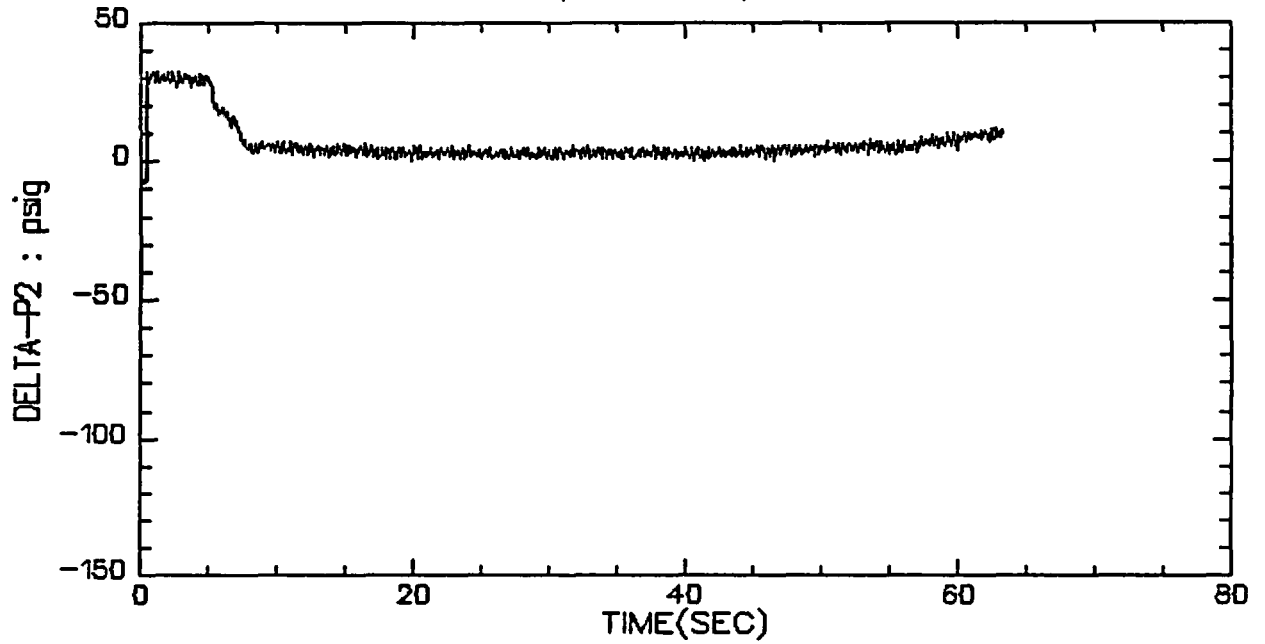

VALVE A, TEST 8, STEP 8&9

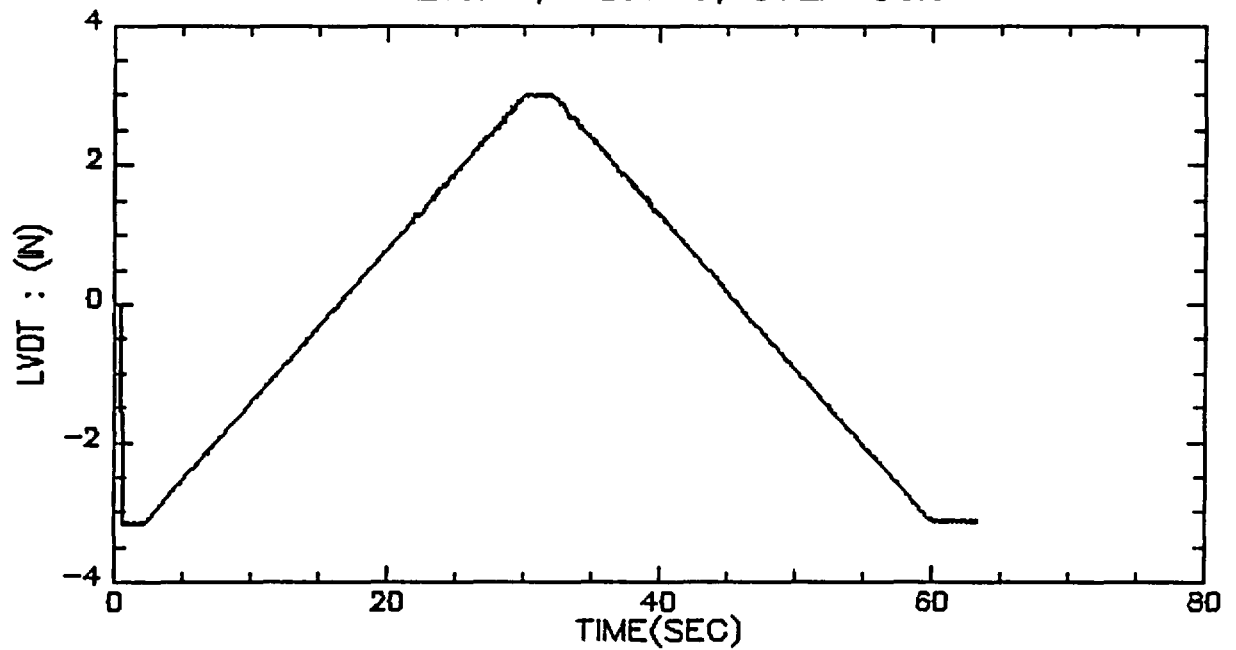

VALVE A, TEST 8, STEP 8&9

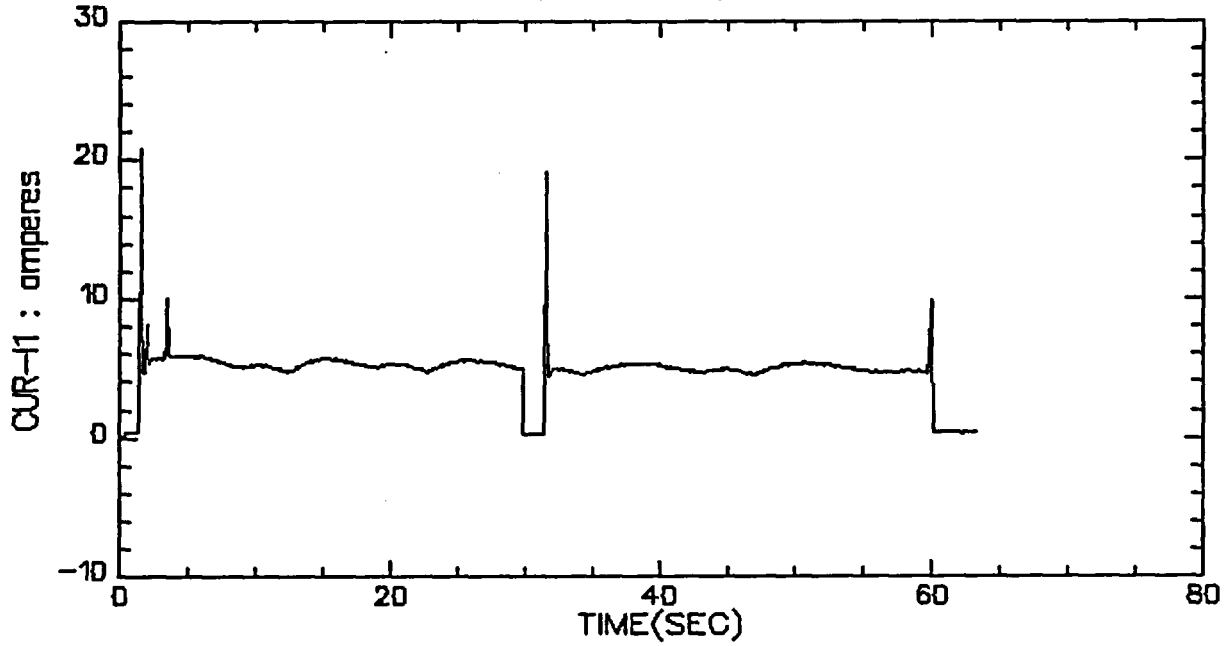

VALVE A, TEST 8, STEP 8&9

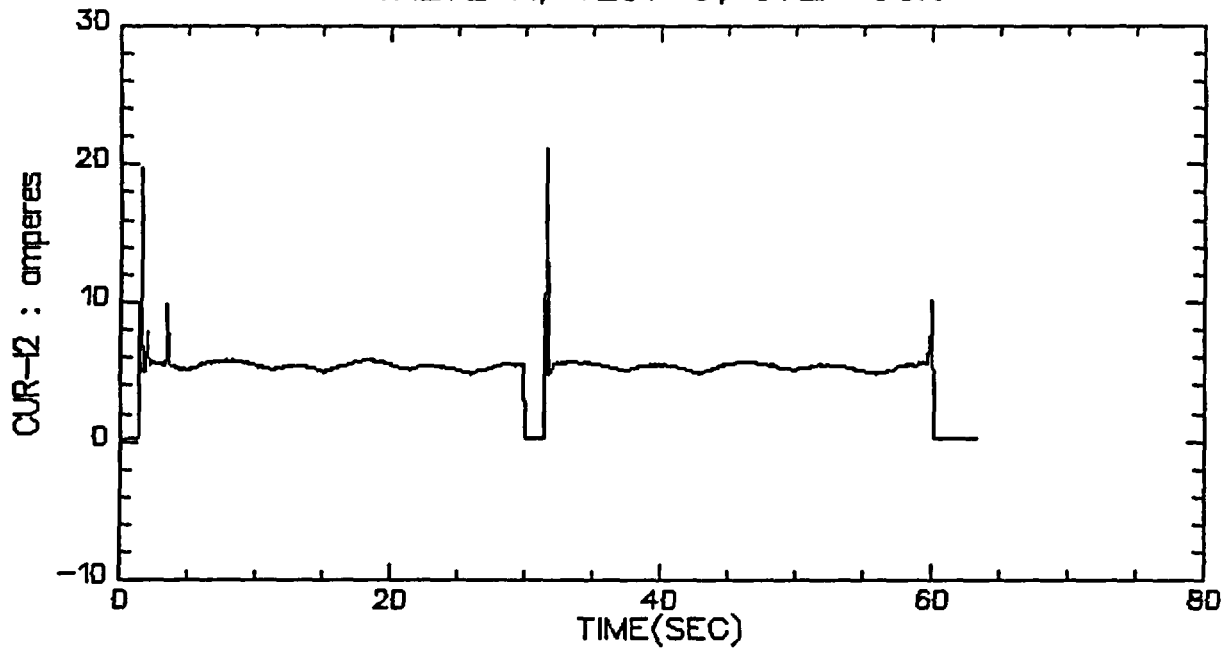

VALVE A, TEST 8, STEP 8&9

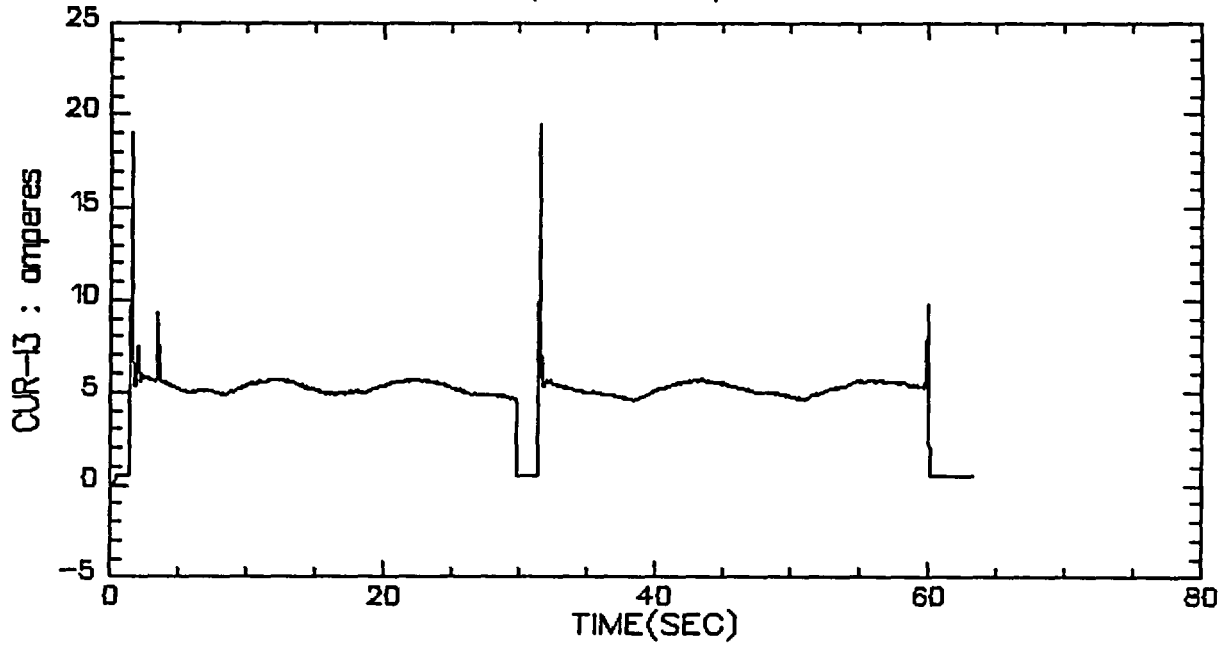

VALVE A, TEST 8, STEP 8&9

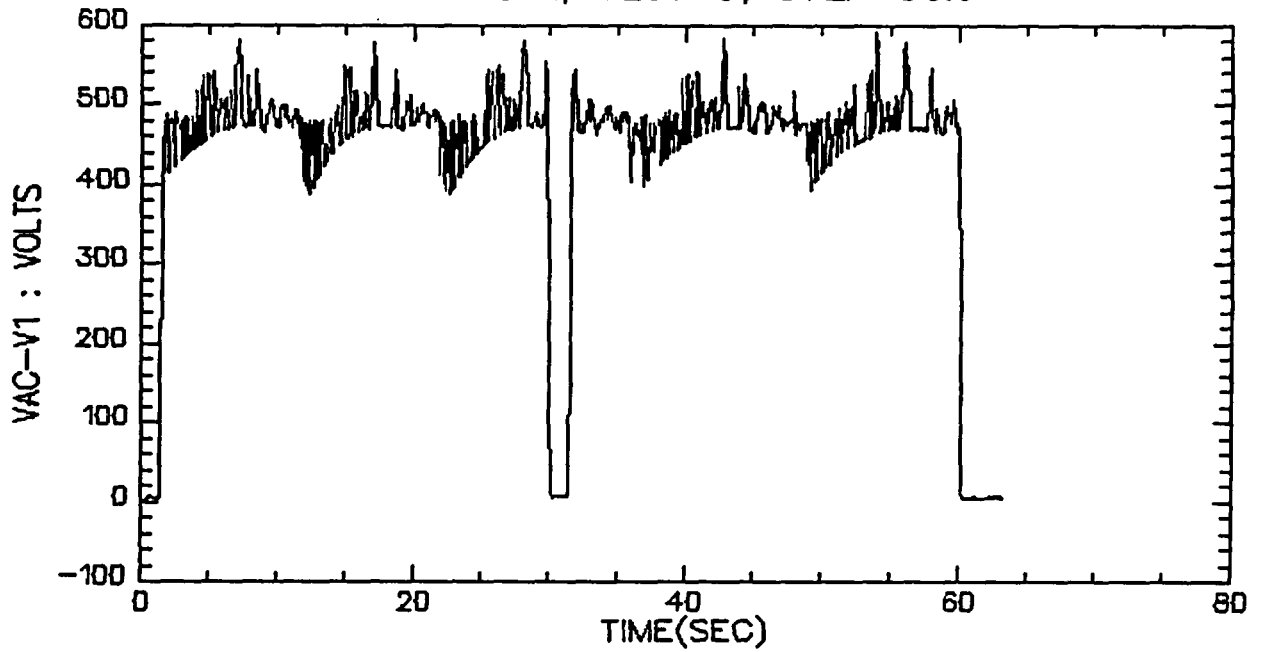

VALVE A, TEST 8, STEP 8&9

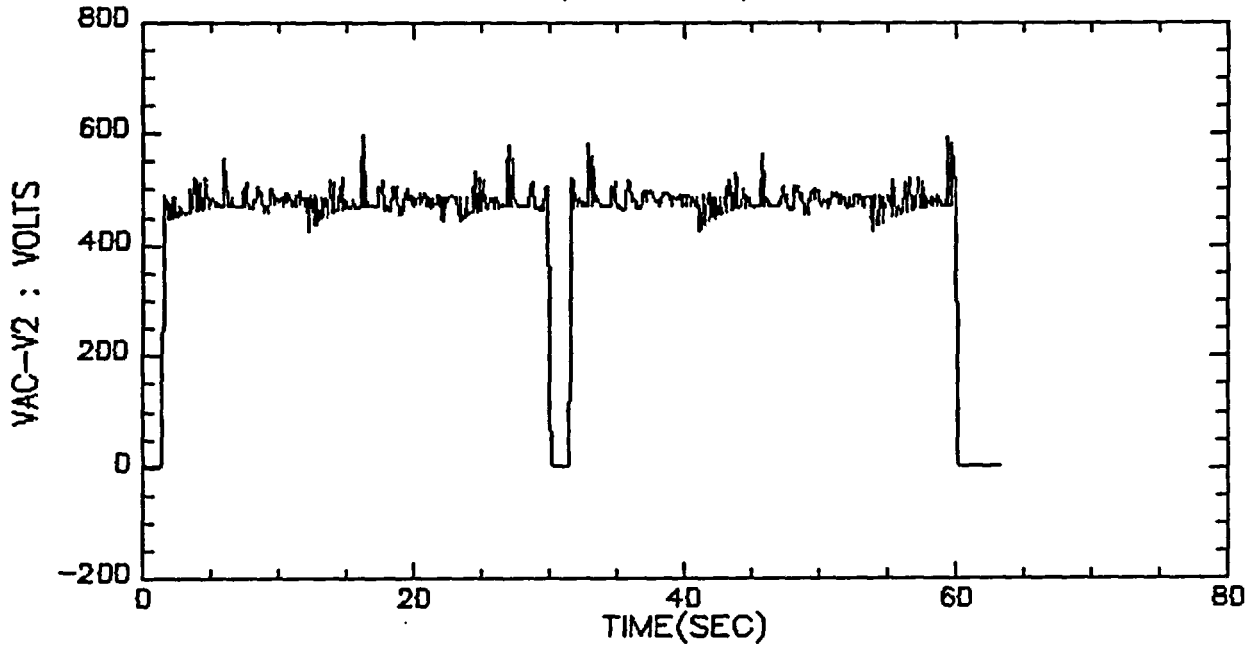

VALVE A, TEST 8, STEP 8&9

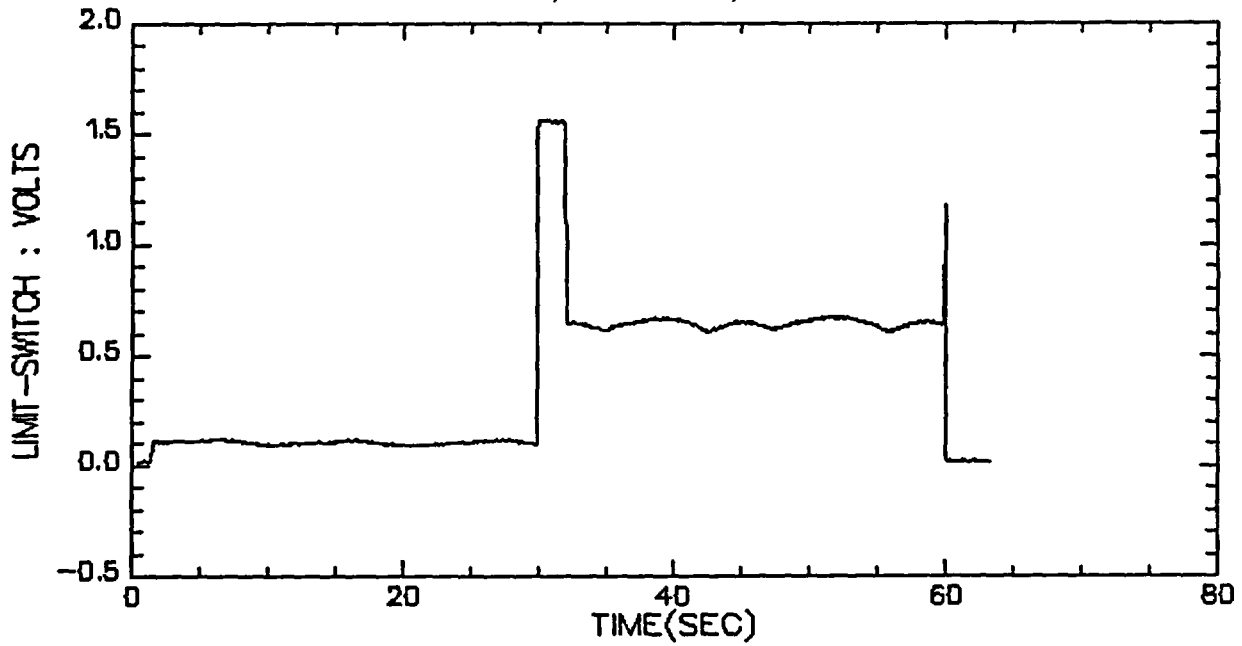

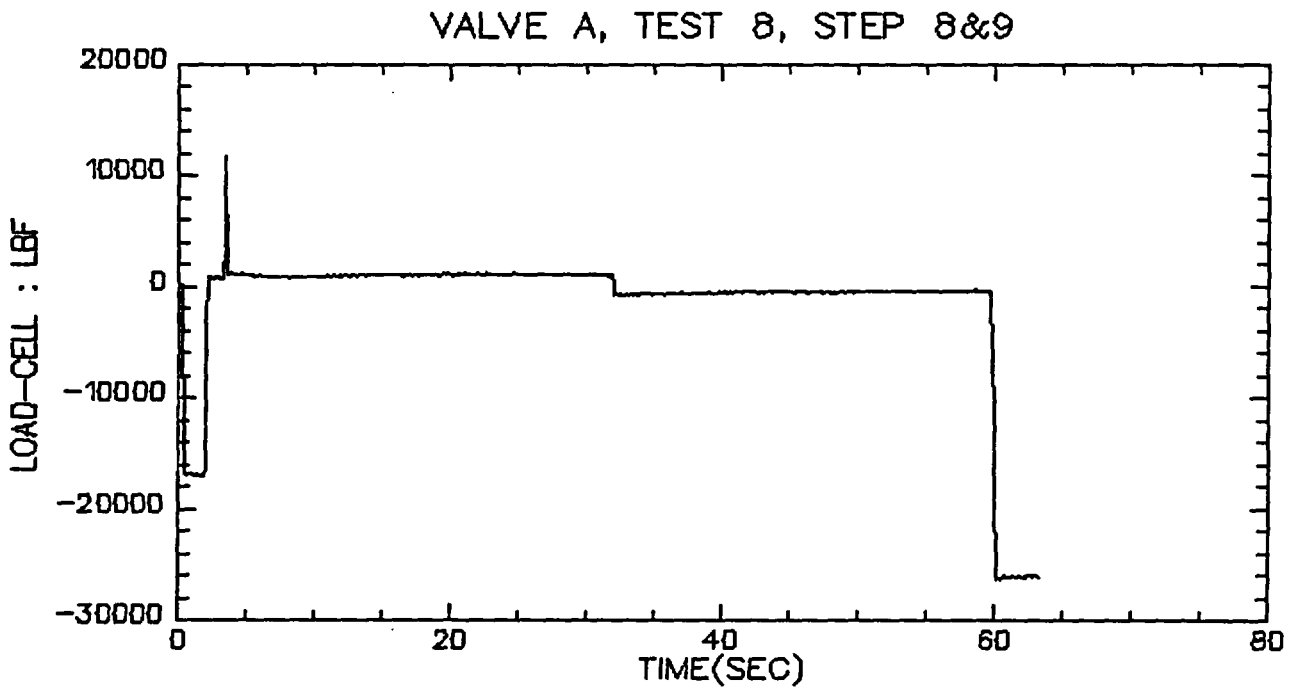
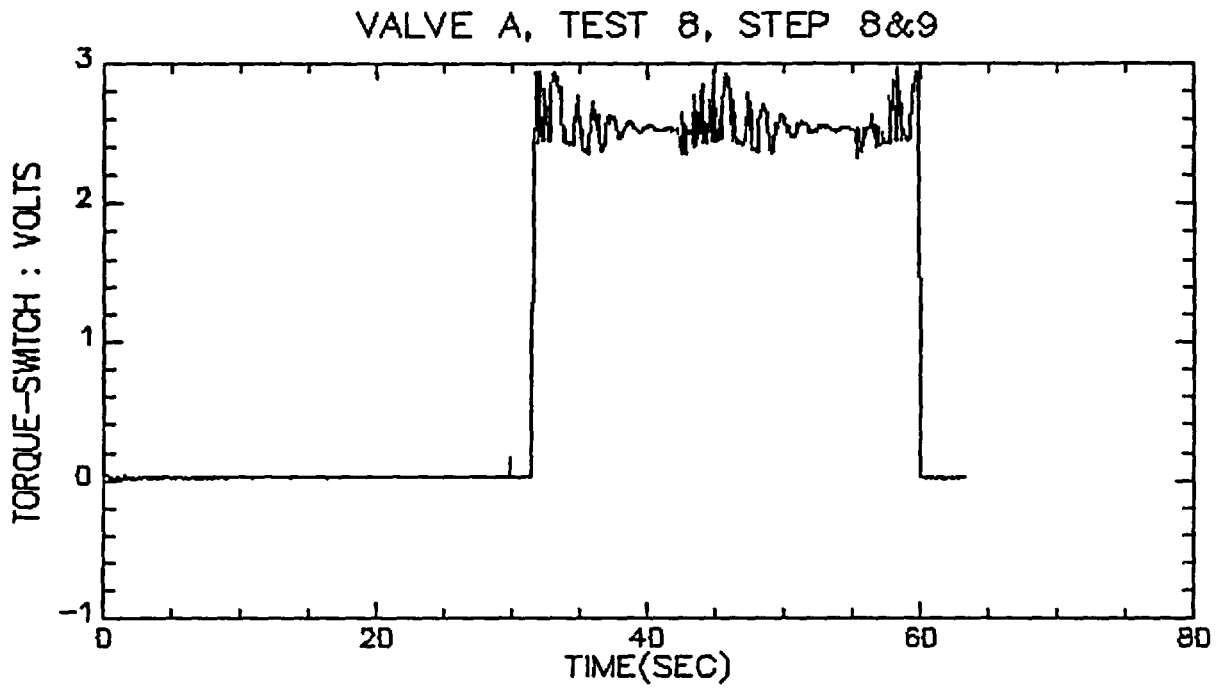

VALVE A, TEST 9, STEP 1

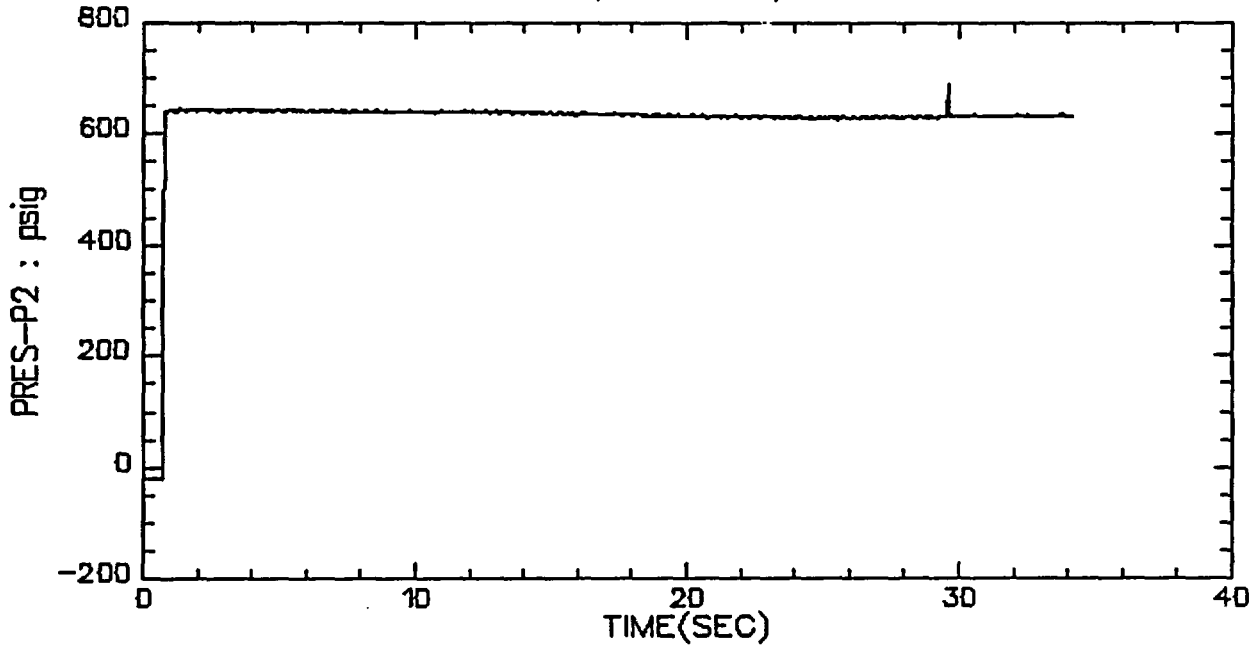

VALVE A, TEST 9, STEP 1

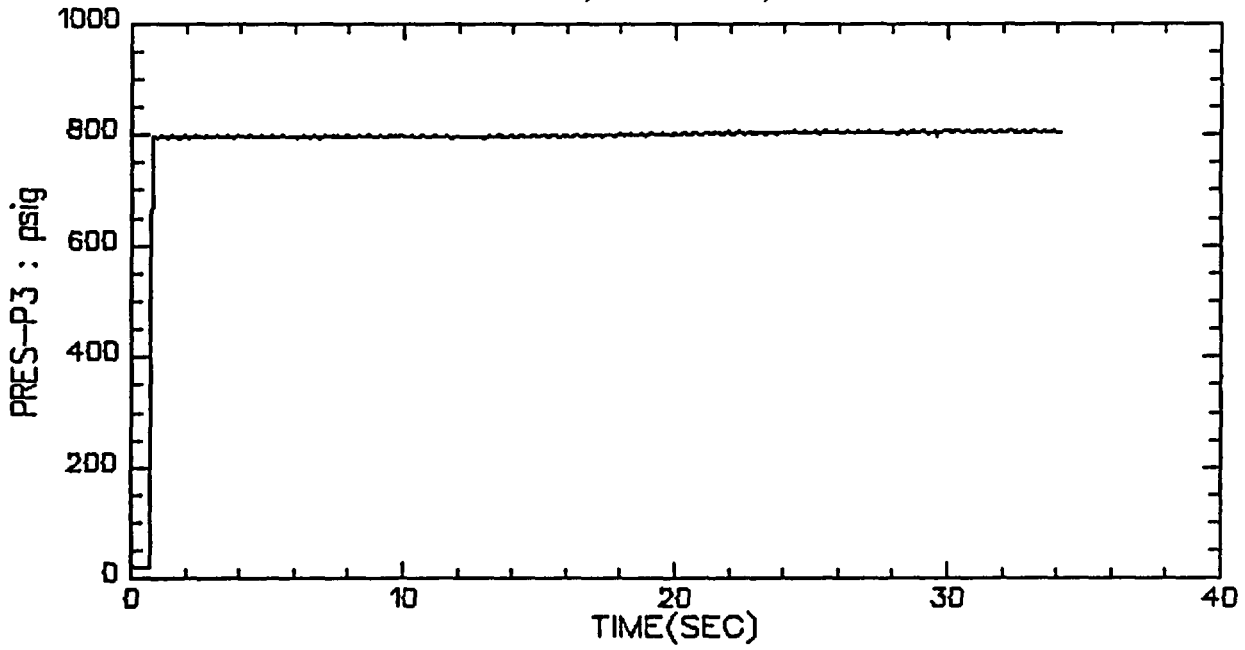

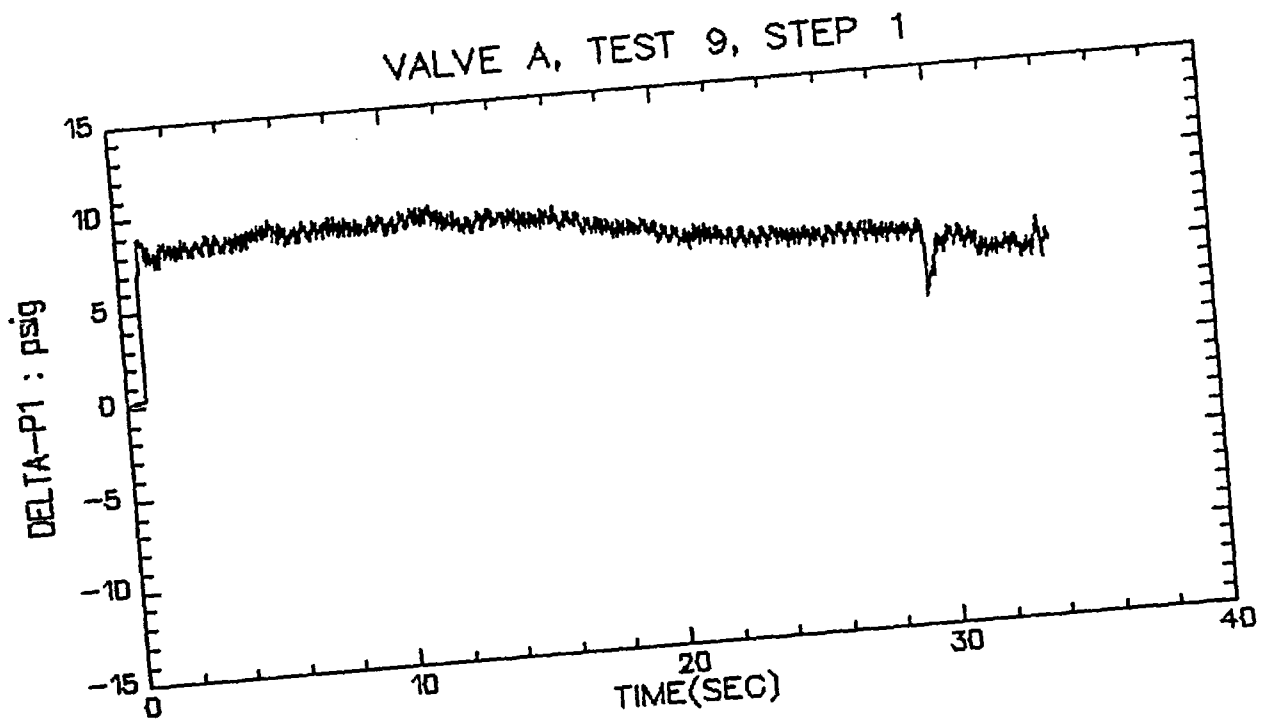
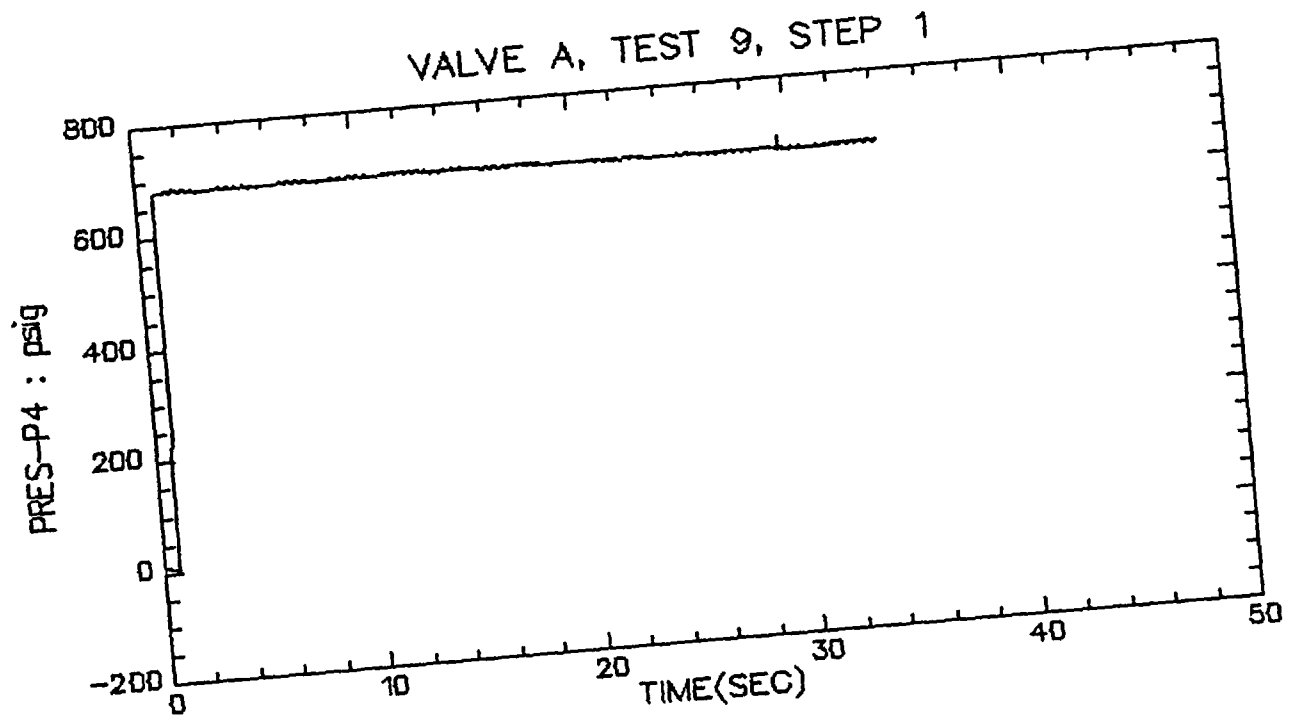

VALVE A, TEST 9, STEP 1

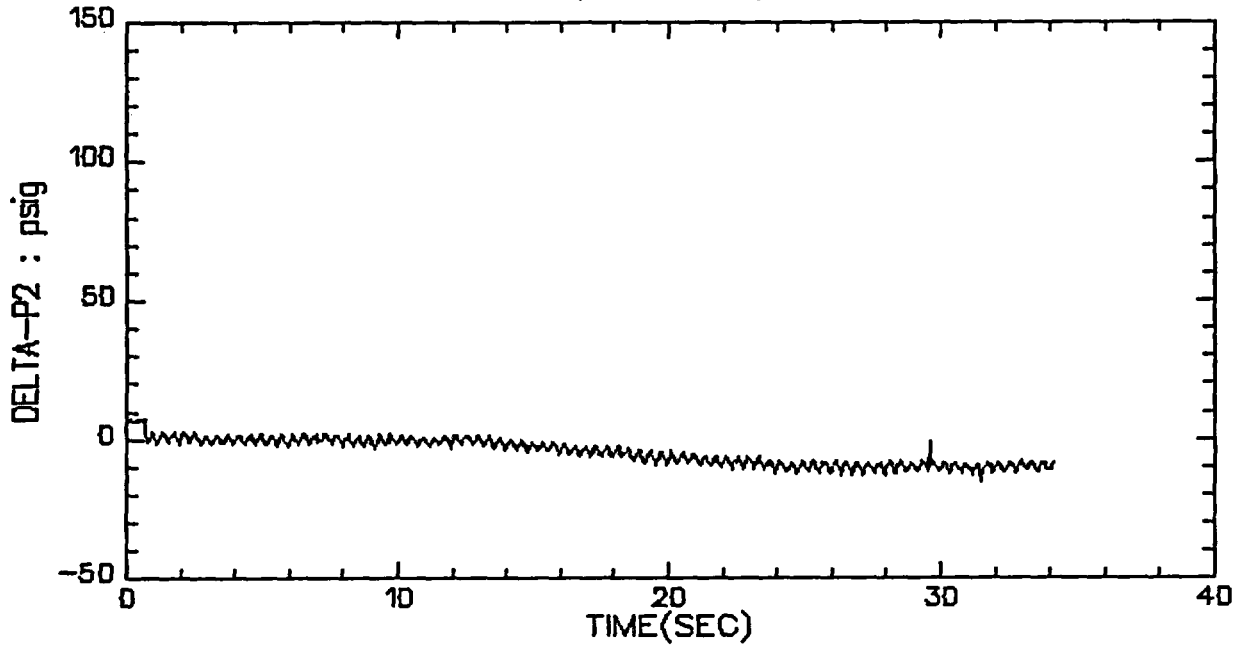

VALVE A, TEST 9, STEP 1

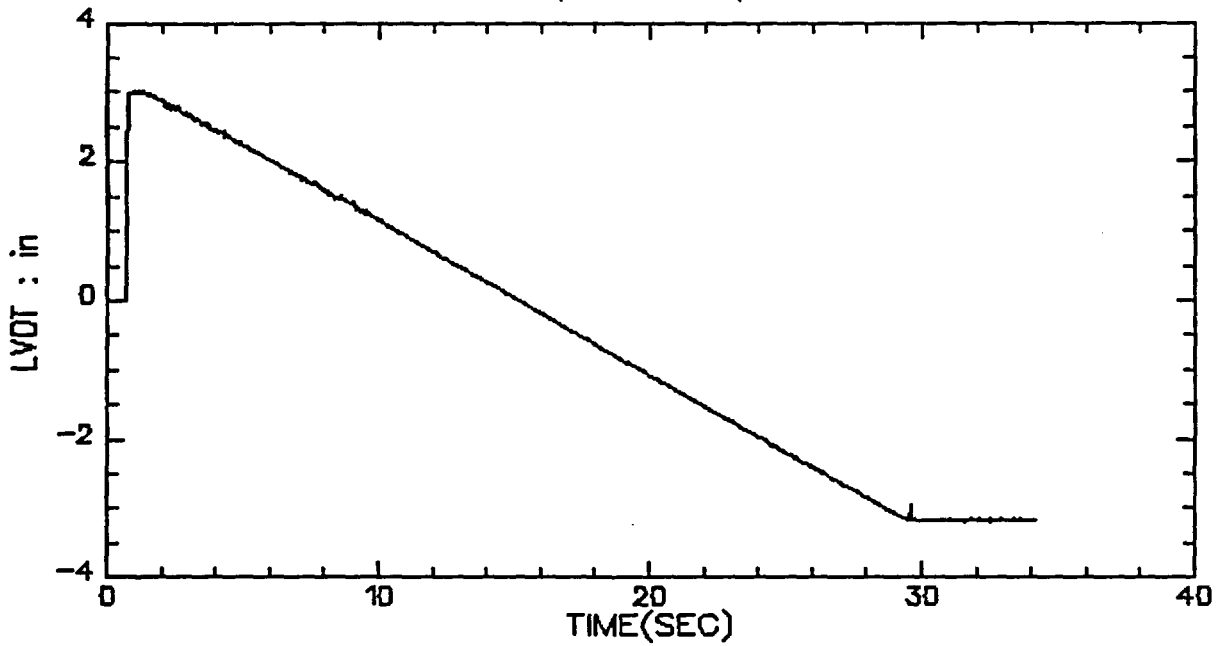

VALVE A, TEST 9, STEP 1

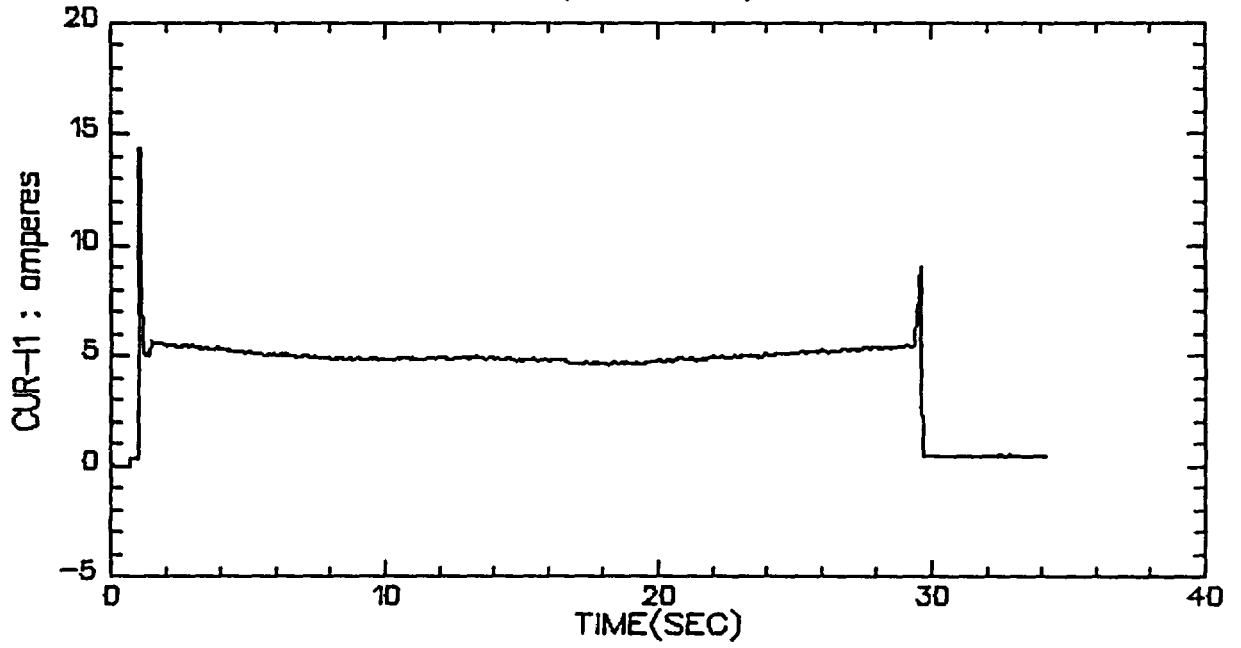

VALVE A, TEST 9, STEP 1

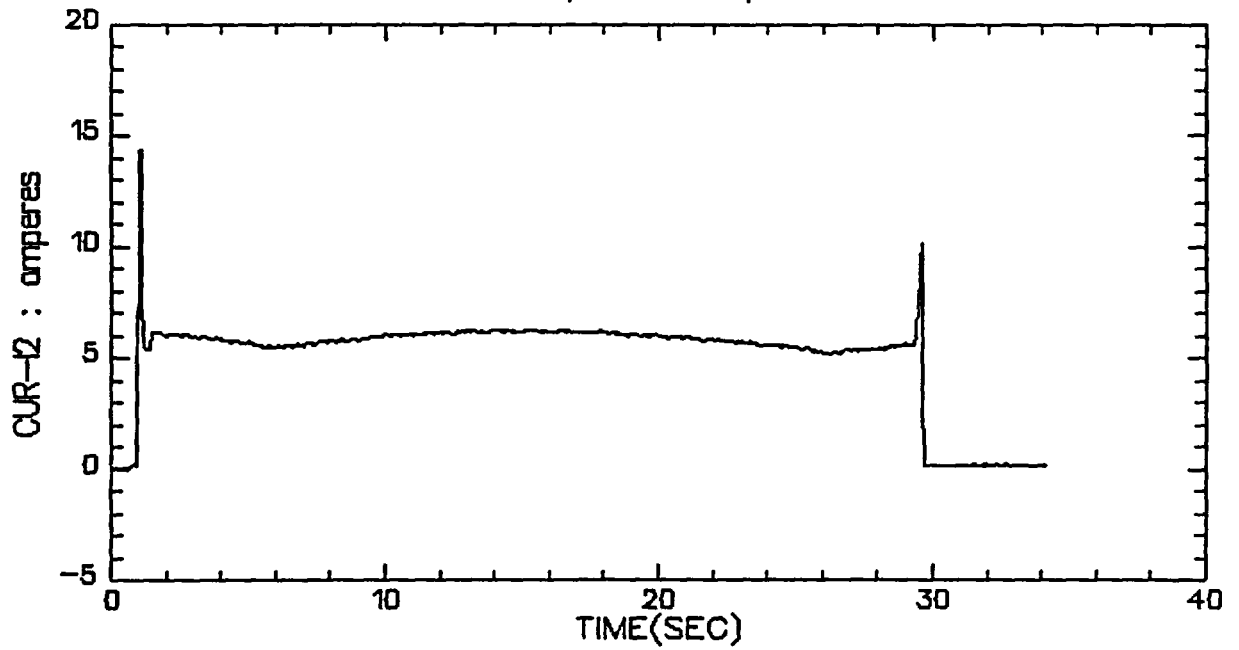

VALVE A, TEST 9, STEP 1

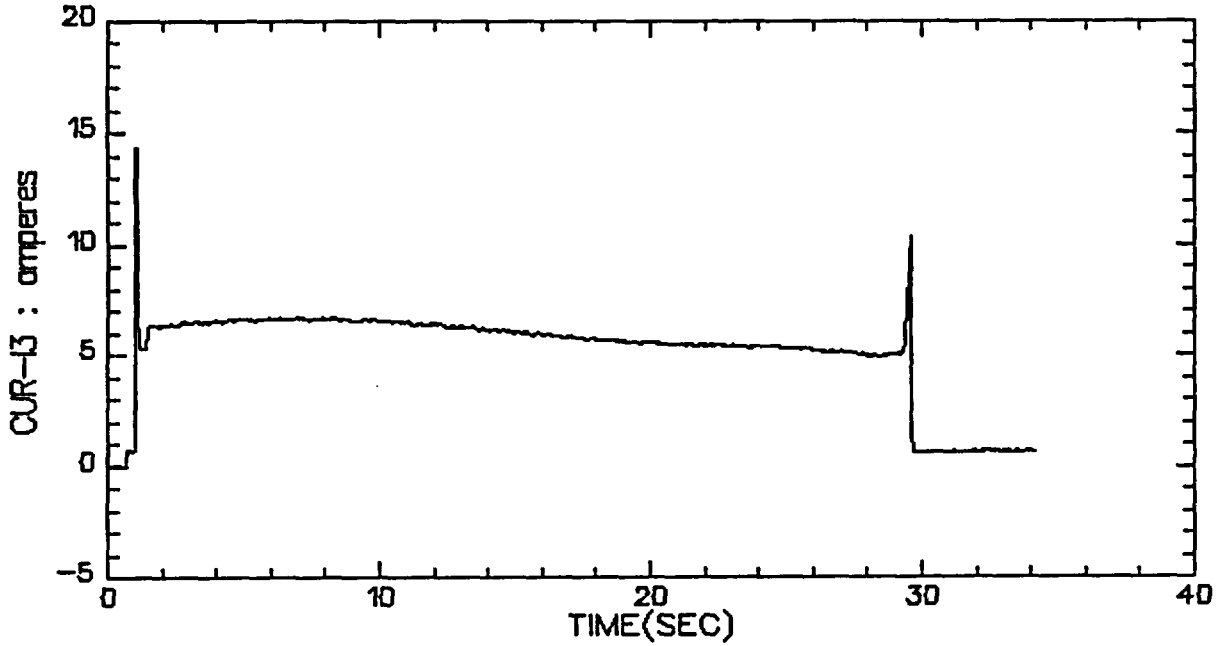

VALVE A, TEST 9, STEP 1

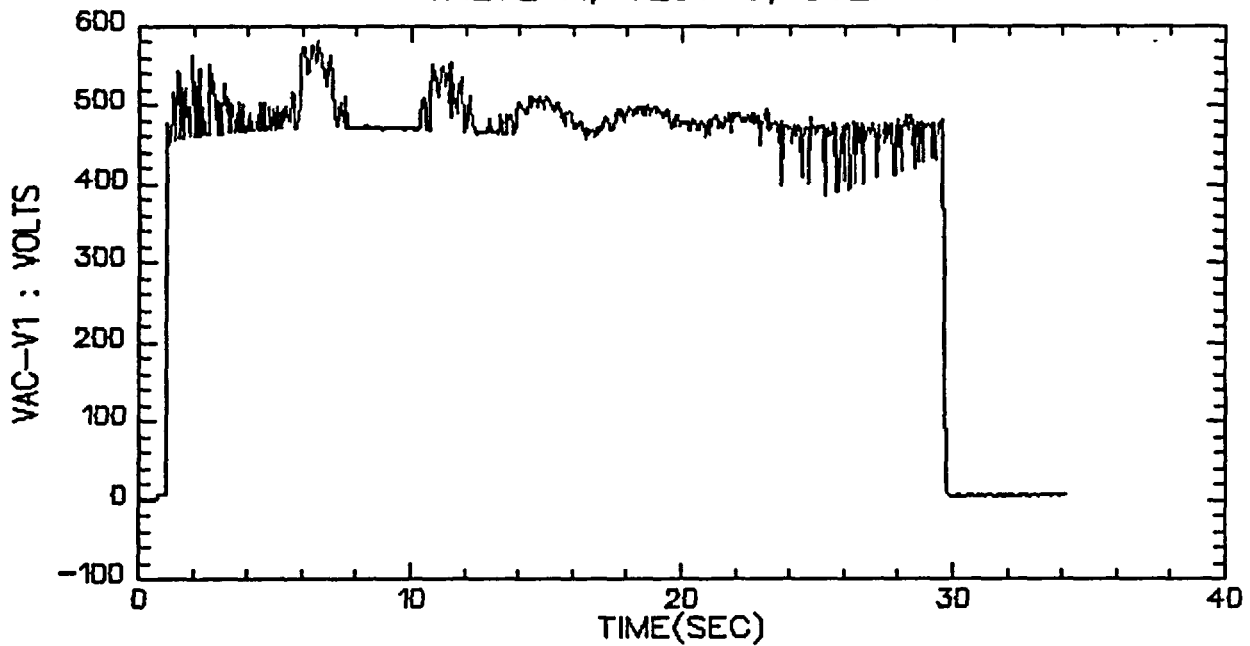

VALVE A, TEST 9, STEP 1

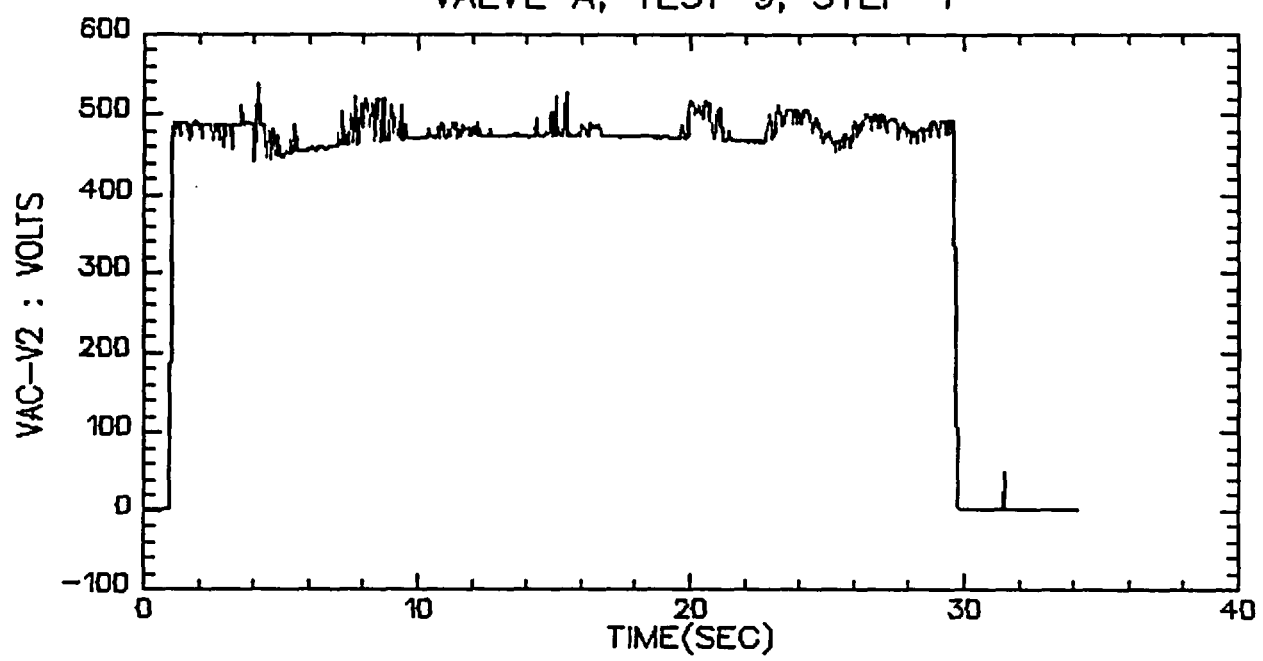

VALVE A, TEST 9, STEP 1

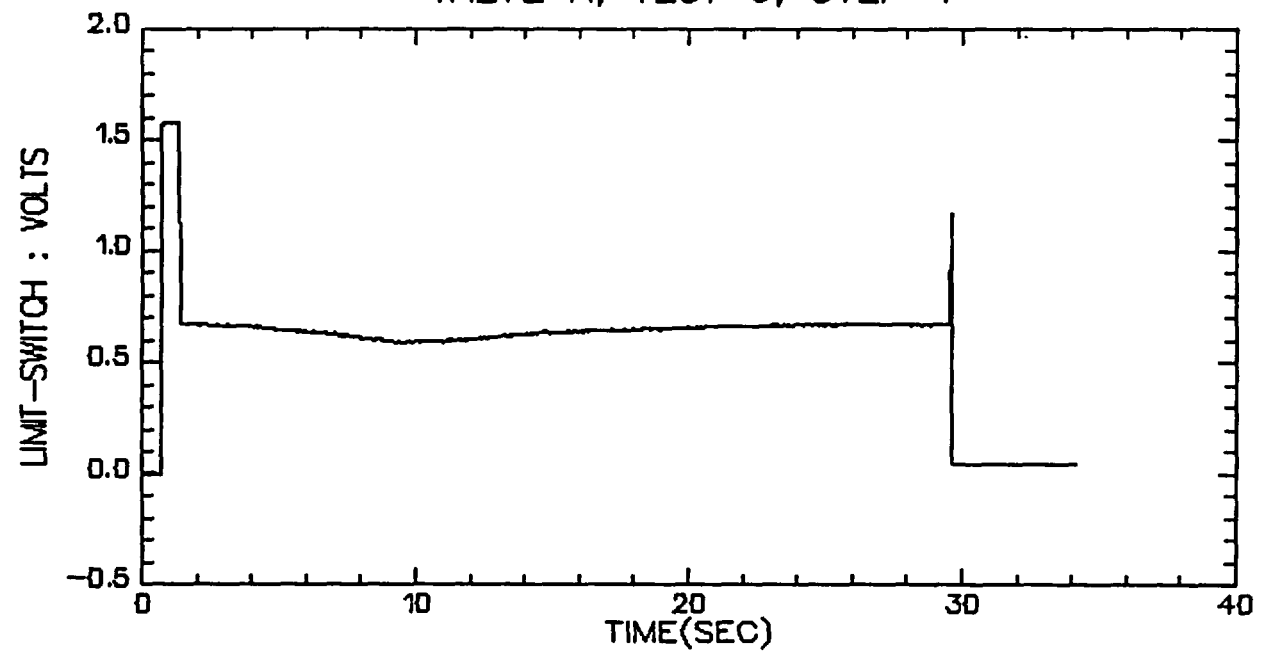

VALVE A, TEST 9, STEP 1

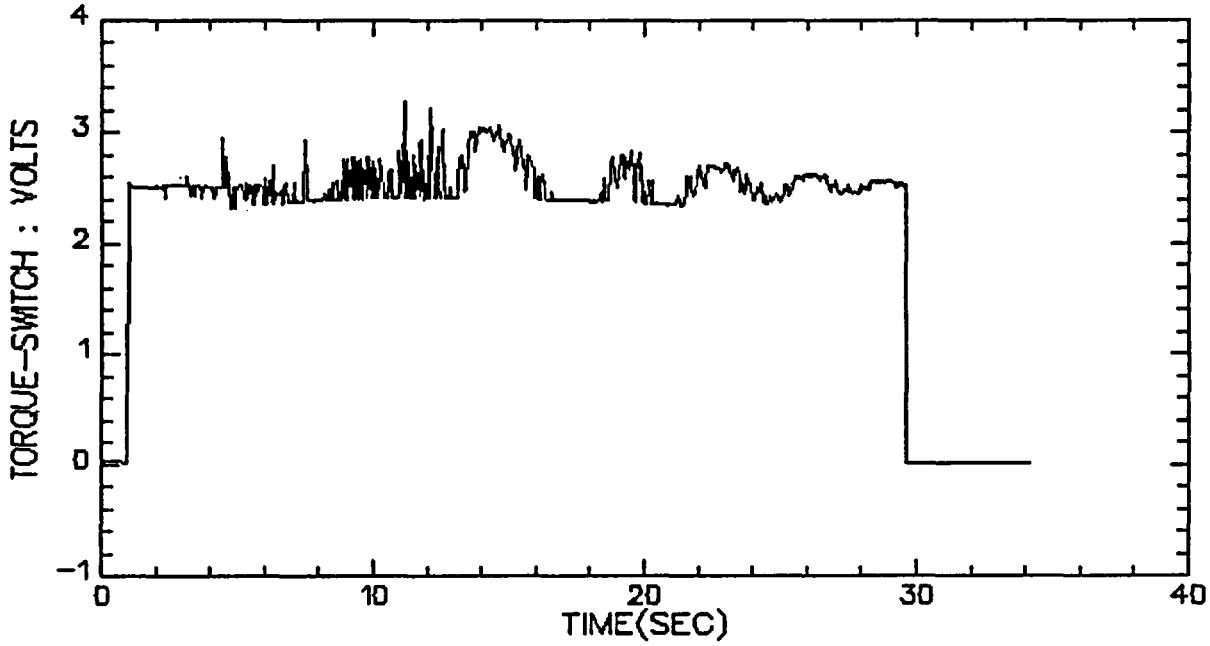

VALVE A, TEST 9, STEP 1

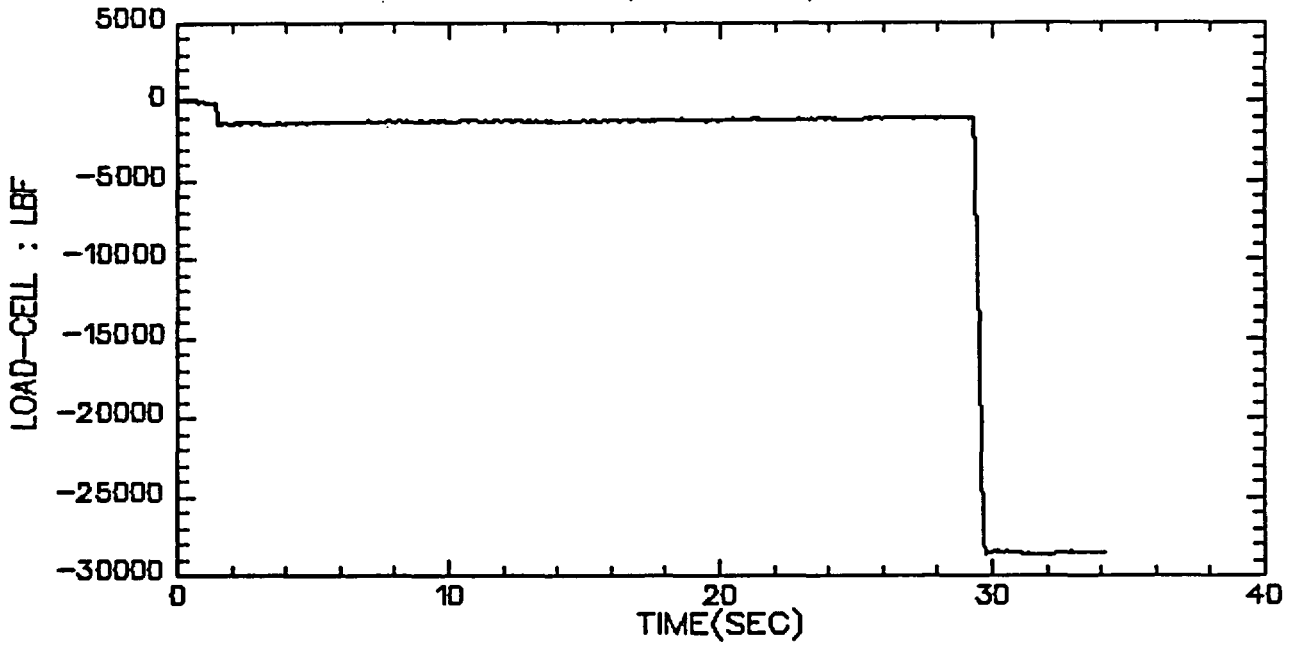

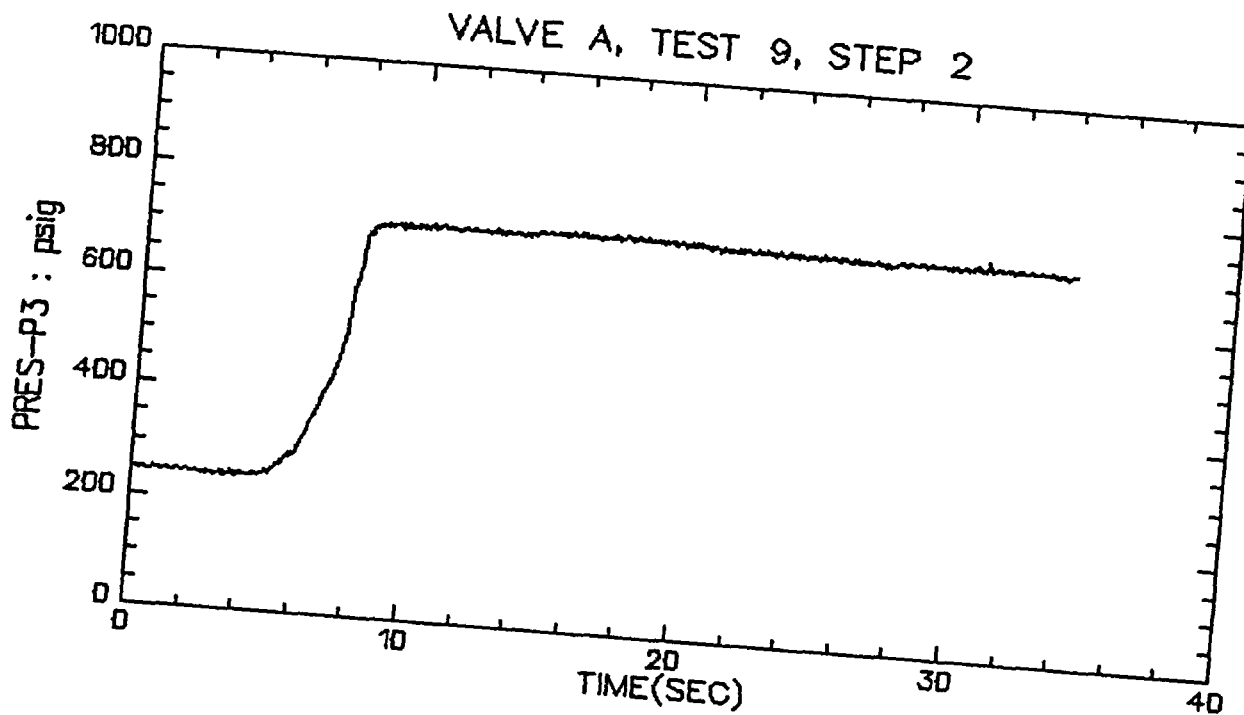
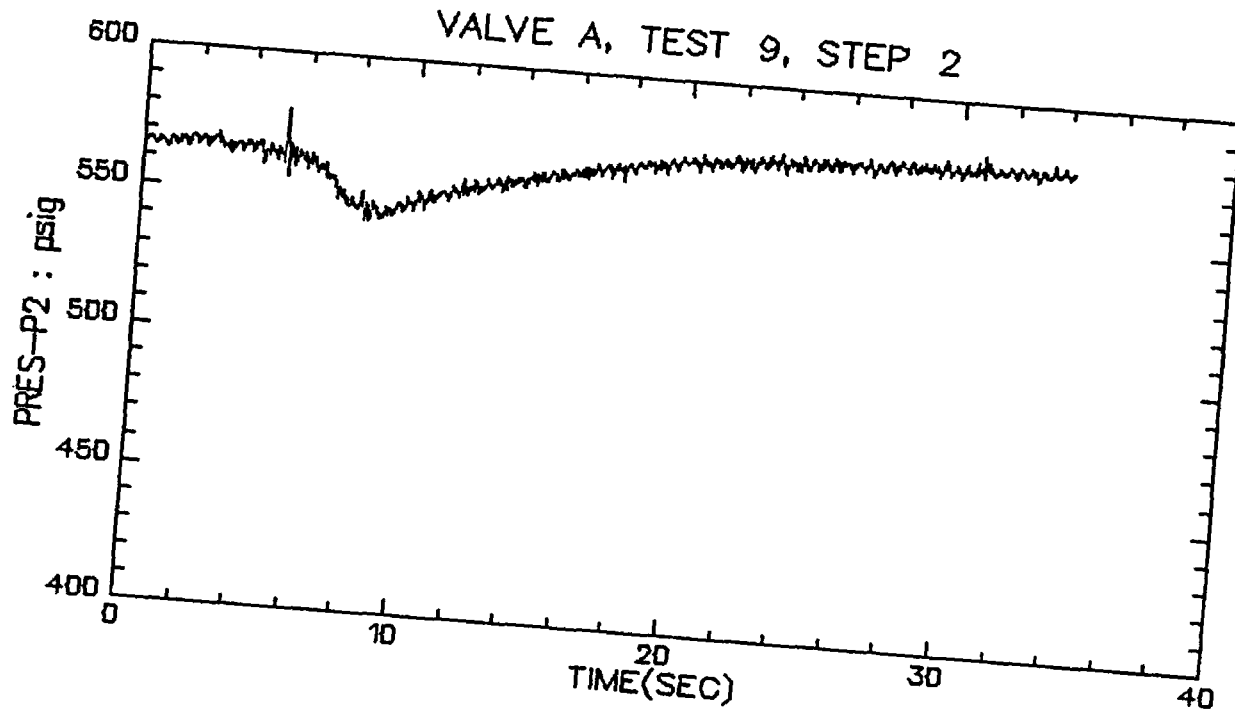

VALVE A, TEST 9, STEP 2

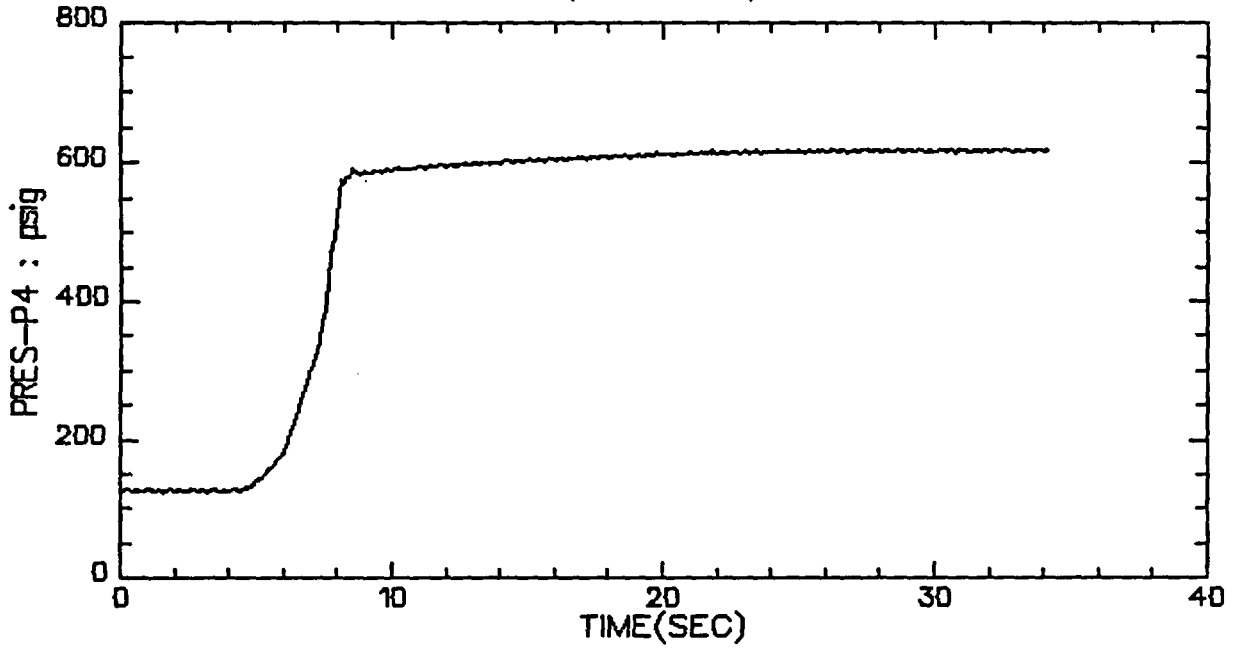

VALVE A, TEST 9, STEP 2

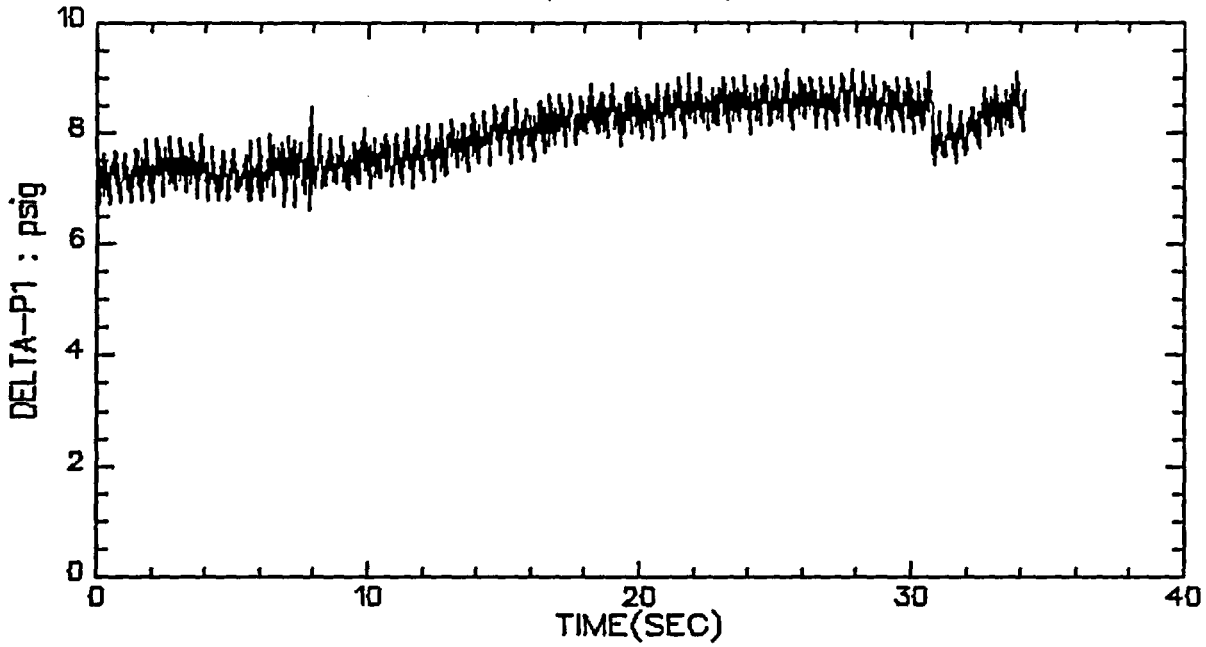

VALVE A, TEST 9, STEP 2

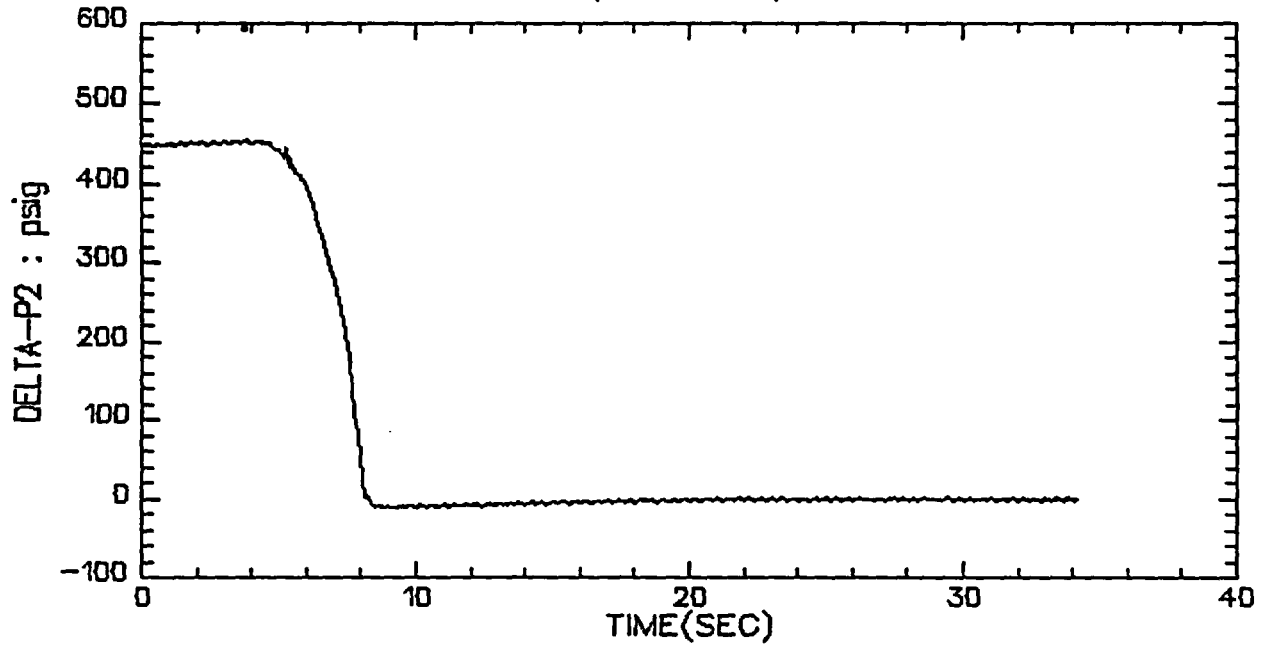

VALVE A, TEST 9, STEP 2

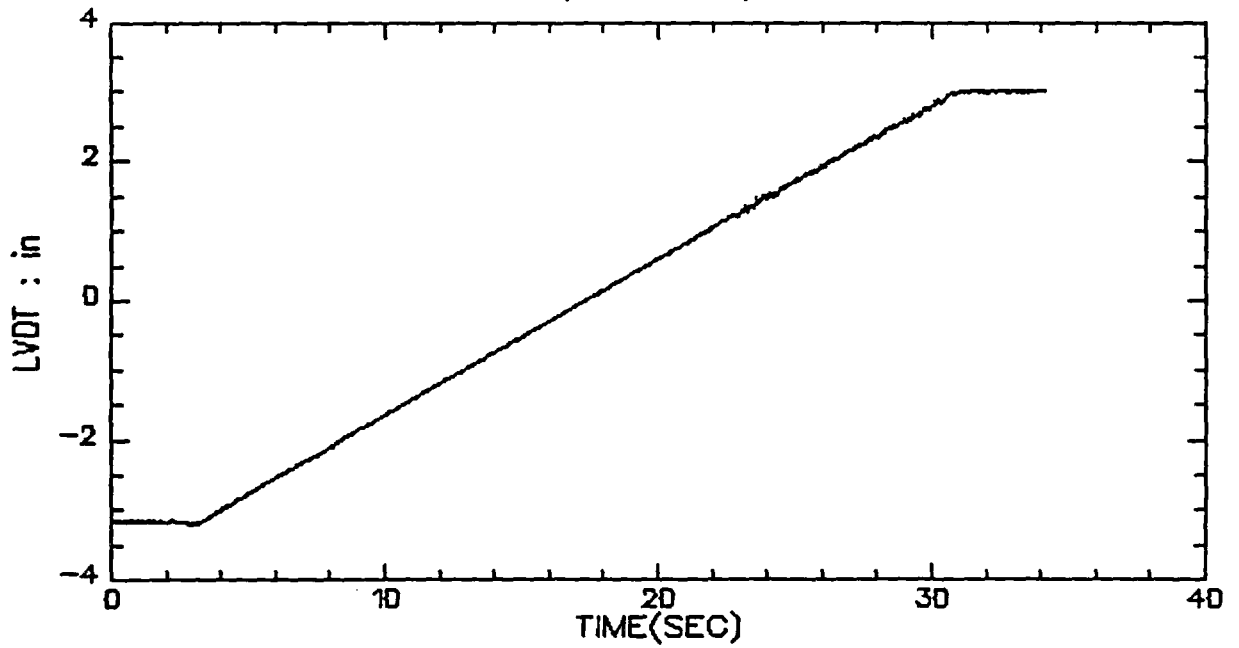

VALVE A, TEST 9, STEP 2

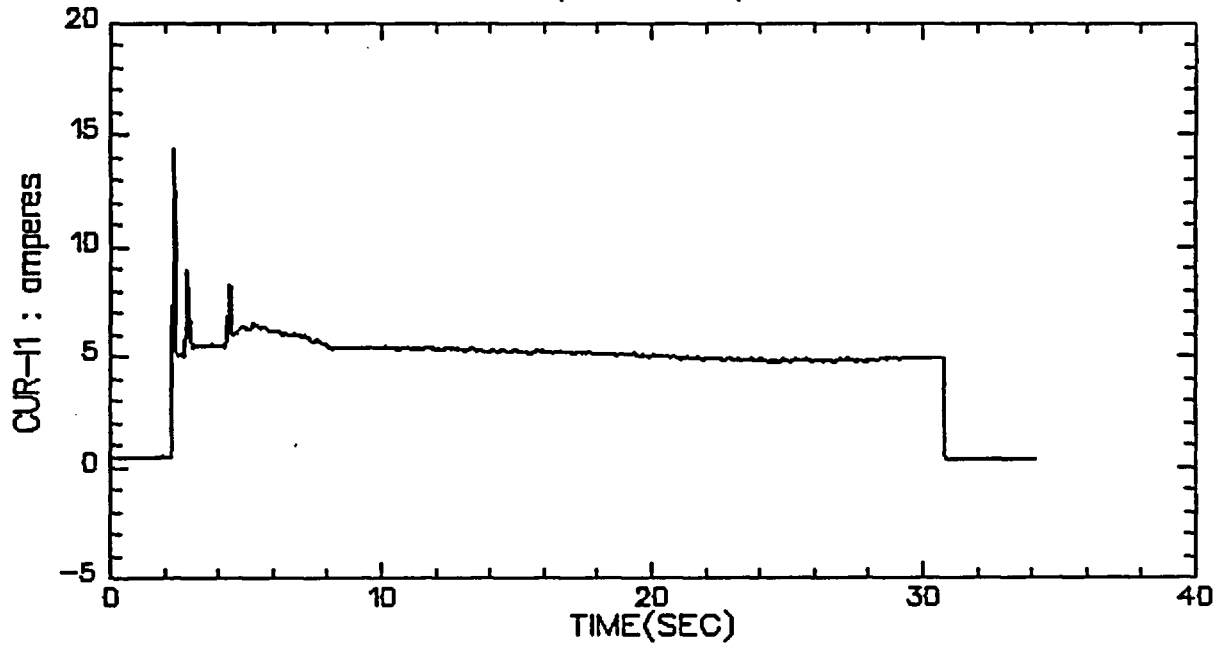

VALVE A, TEST 9, STEP 2

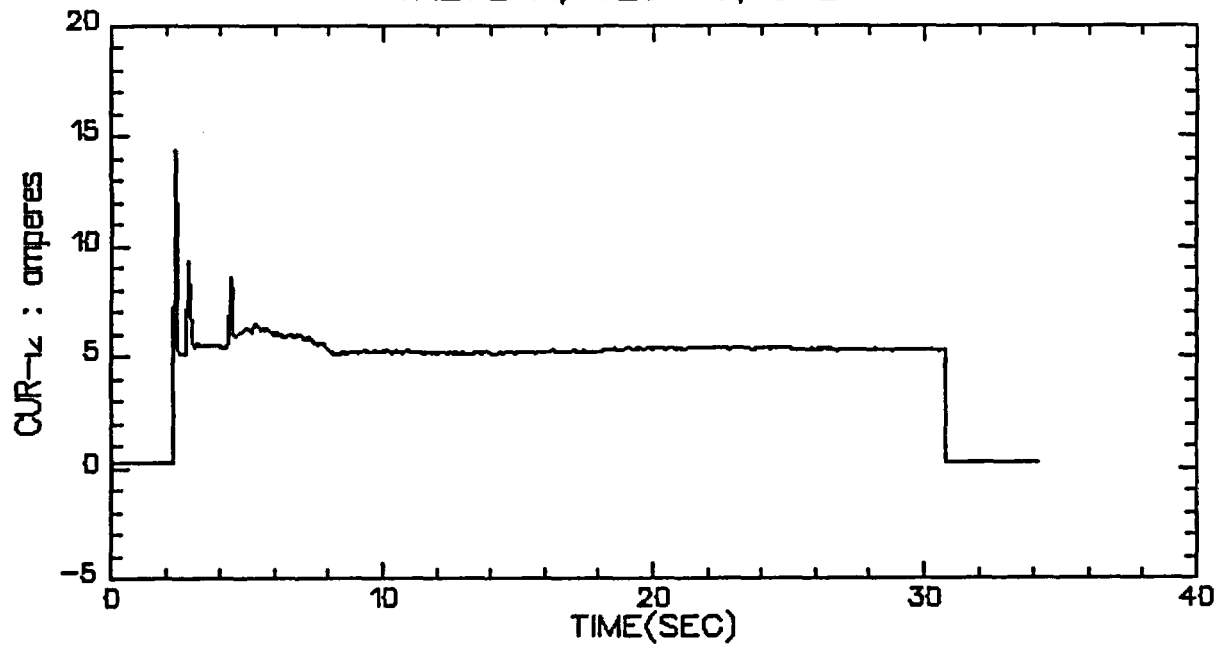

VALVE A, TEST 9, STEP 2

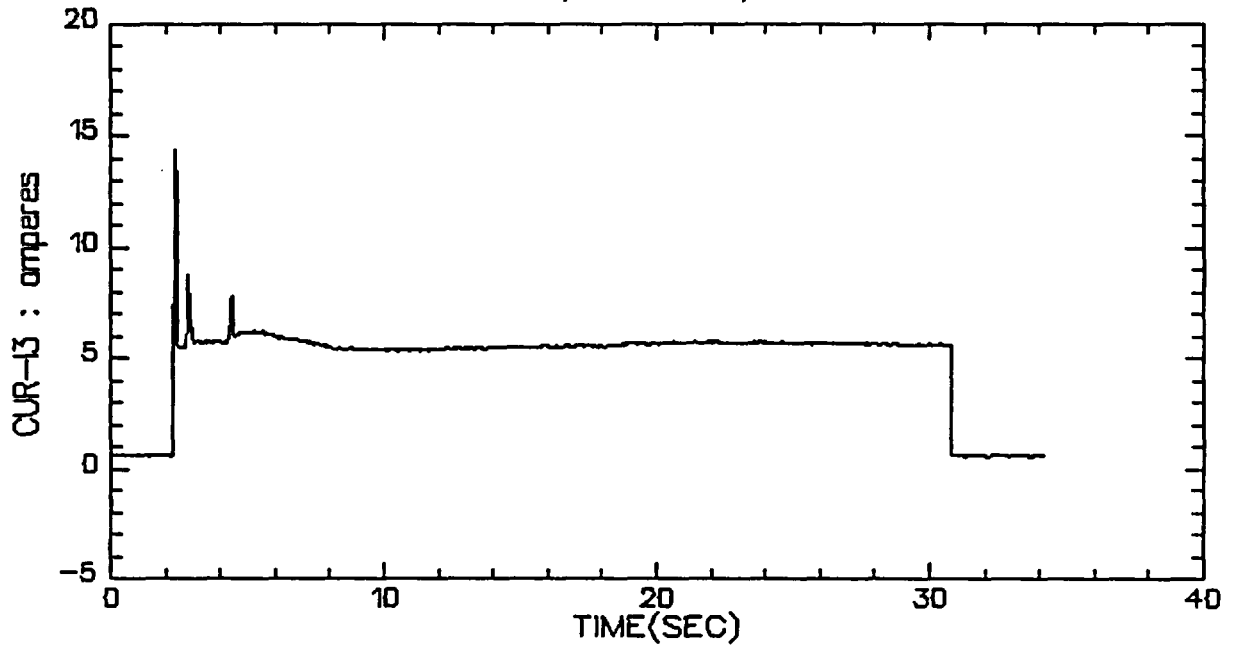

VALVE A, TEST 9, STEP 2

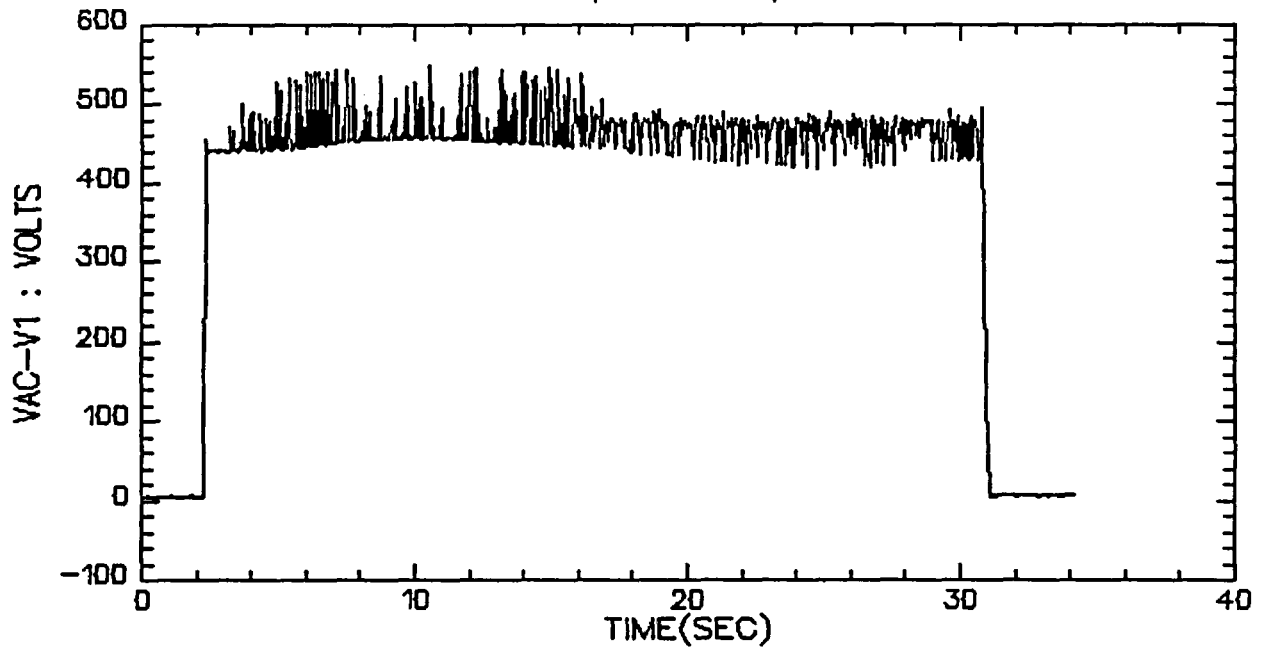

VALVE A, TEST 9, STEP 2

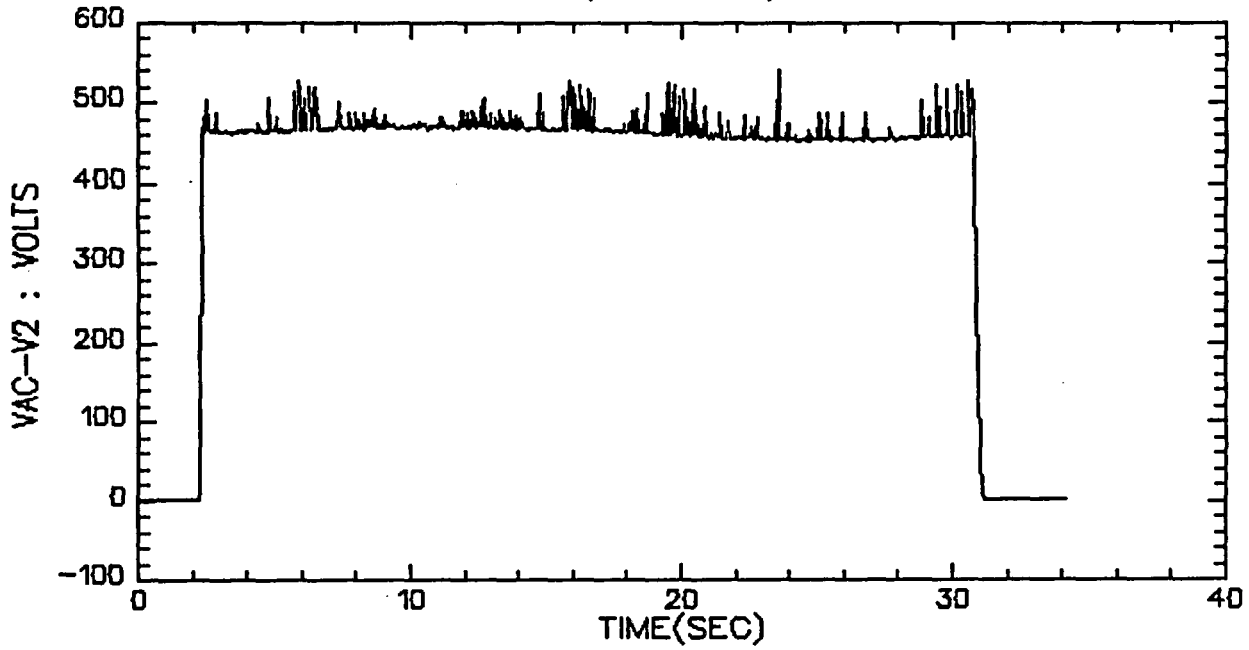

VALVE A, TEST 9, STEP 2

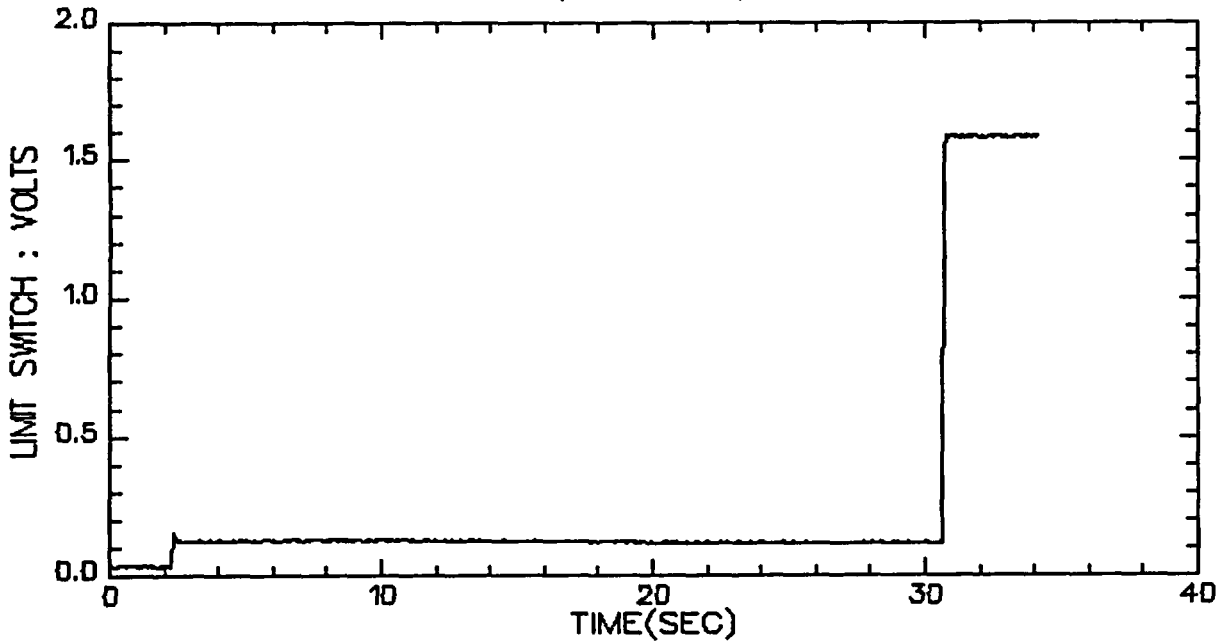

VALVE A, TEST 9, STEP 2

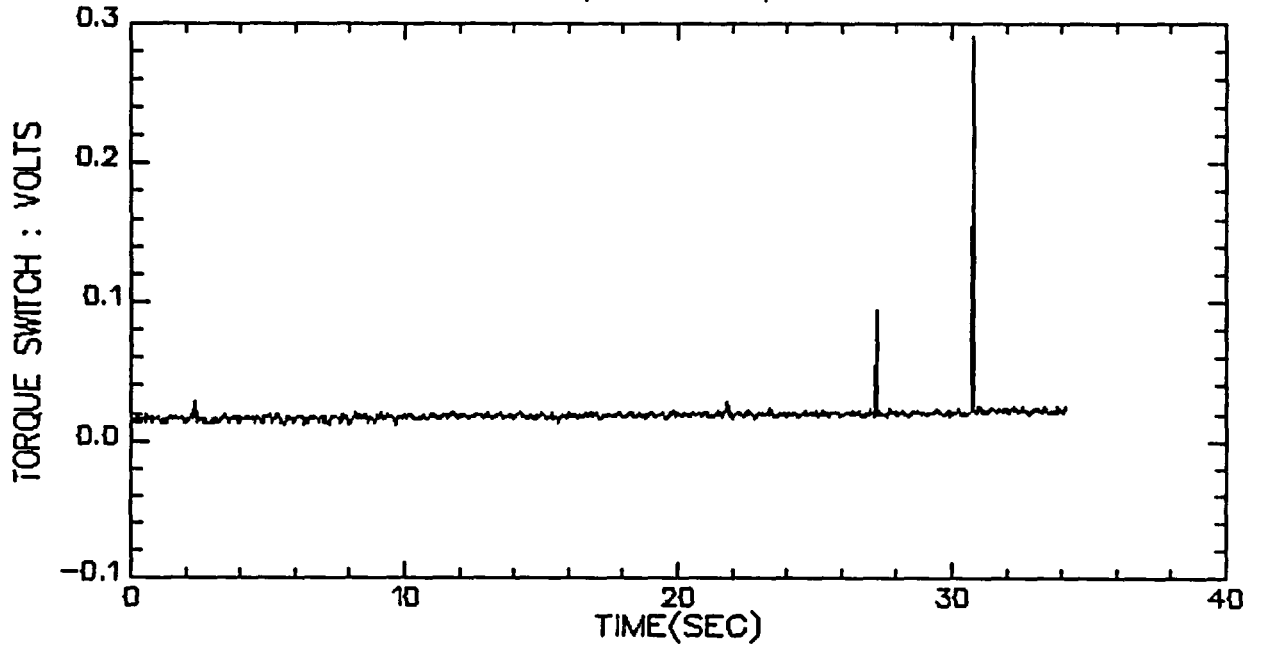

VALVE A, TEST 9, STEP 2

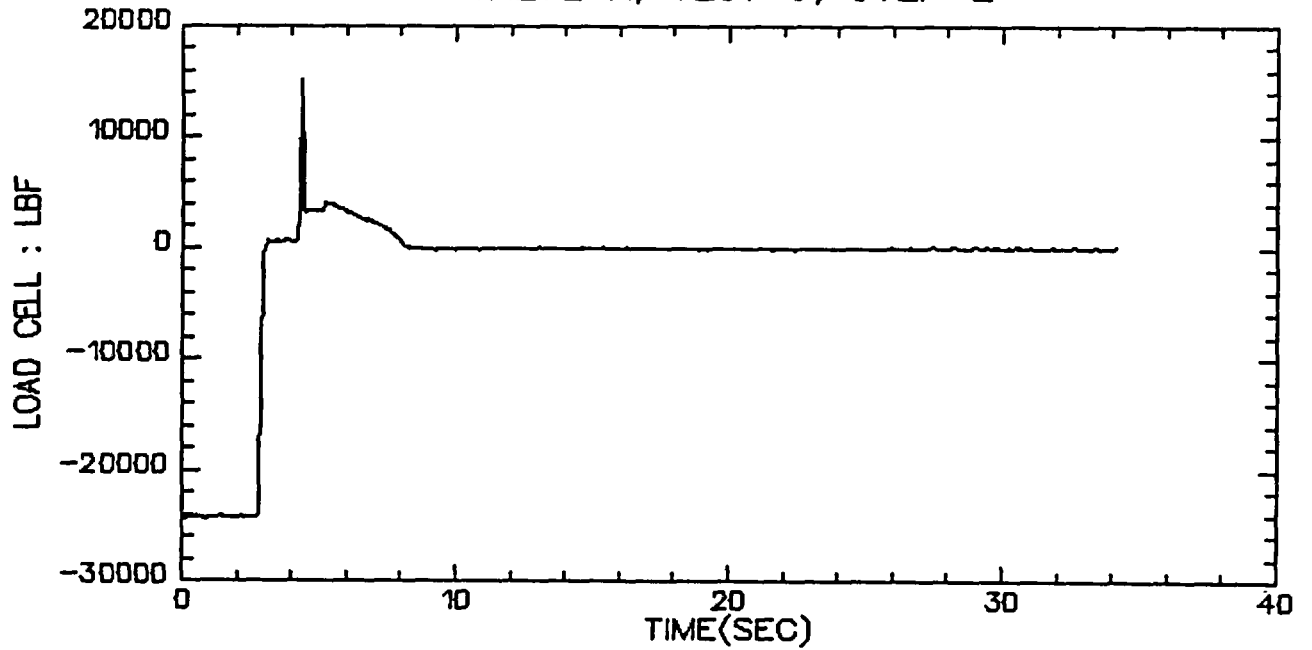

VALVE A, TEST 9, STEP 3&4

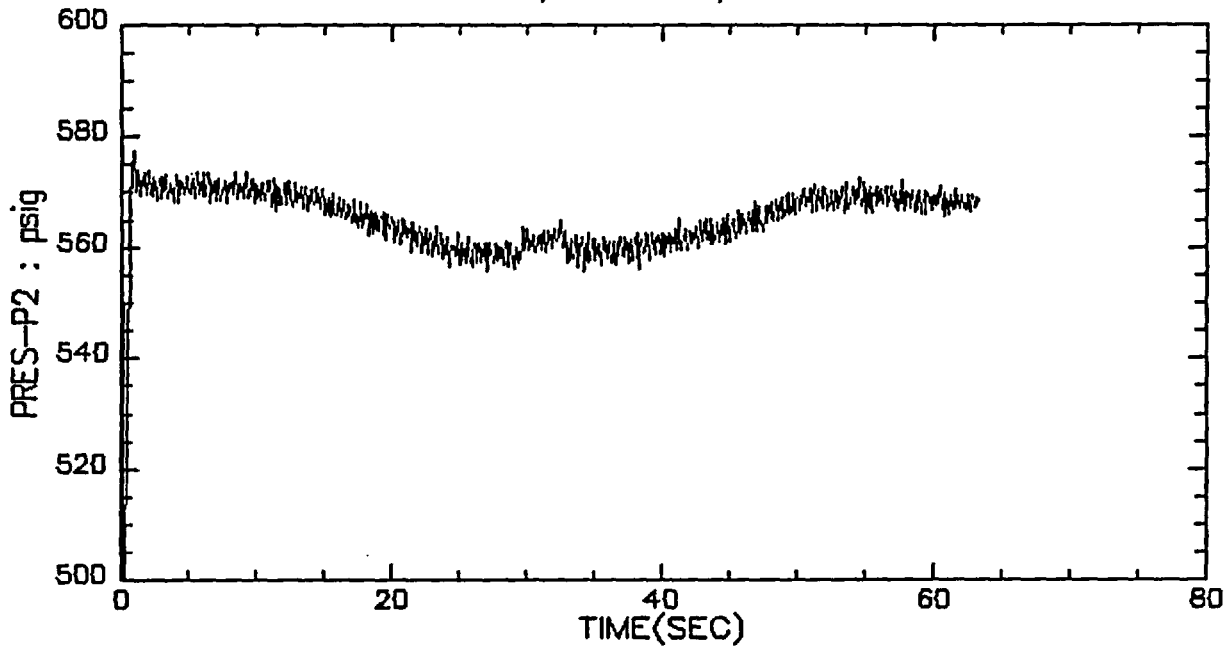

VALVE A, TEST 9, STEP 3&4

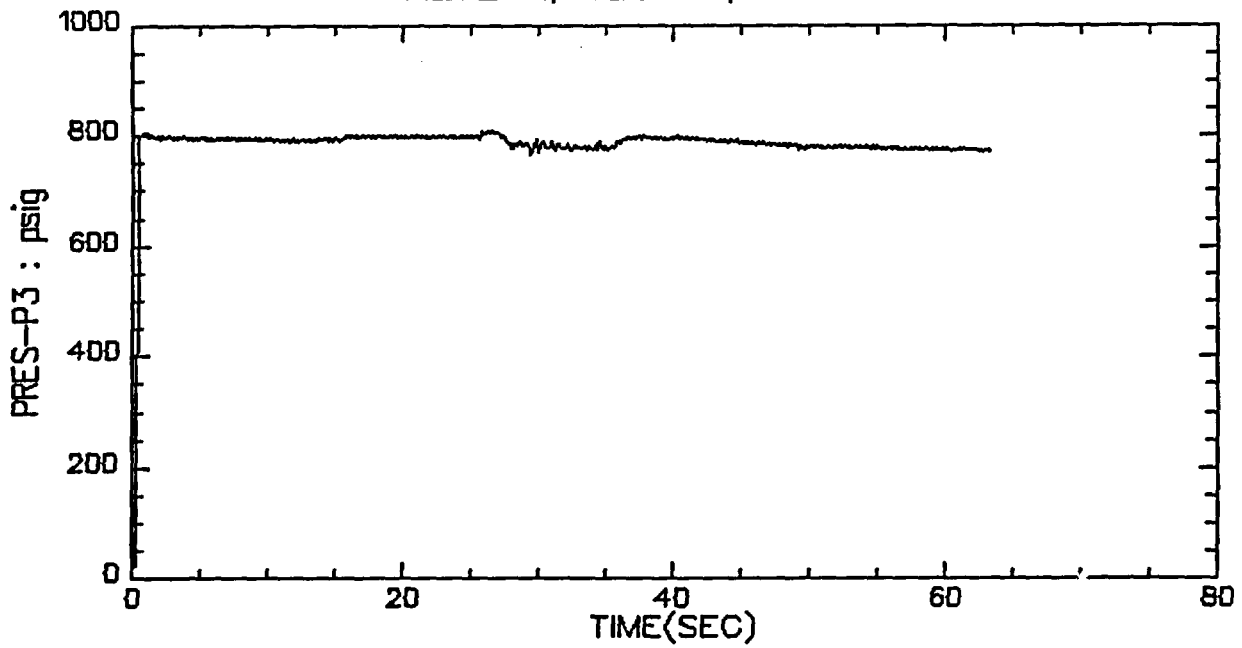

VALVE A, TEST 9, STEP 3&4

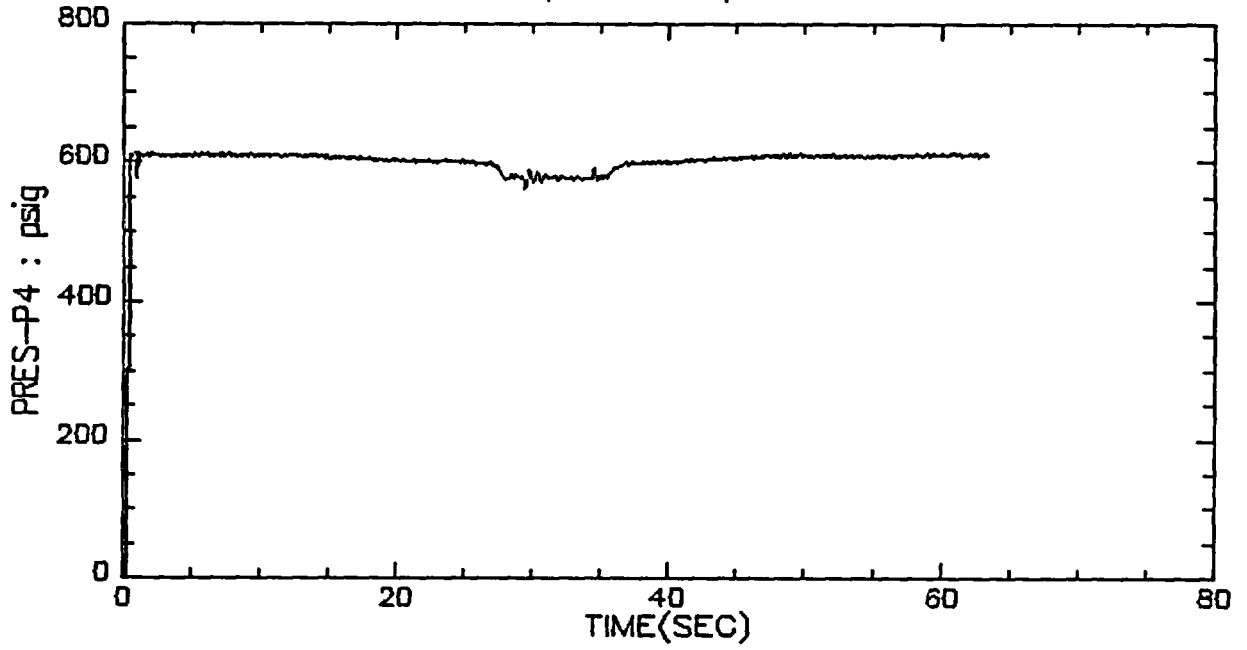

VALVE A, TEST 9, STEP 3&4

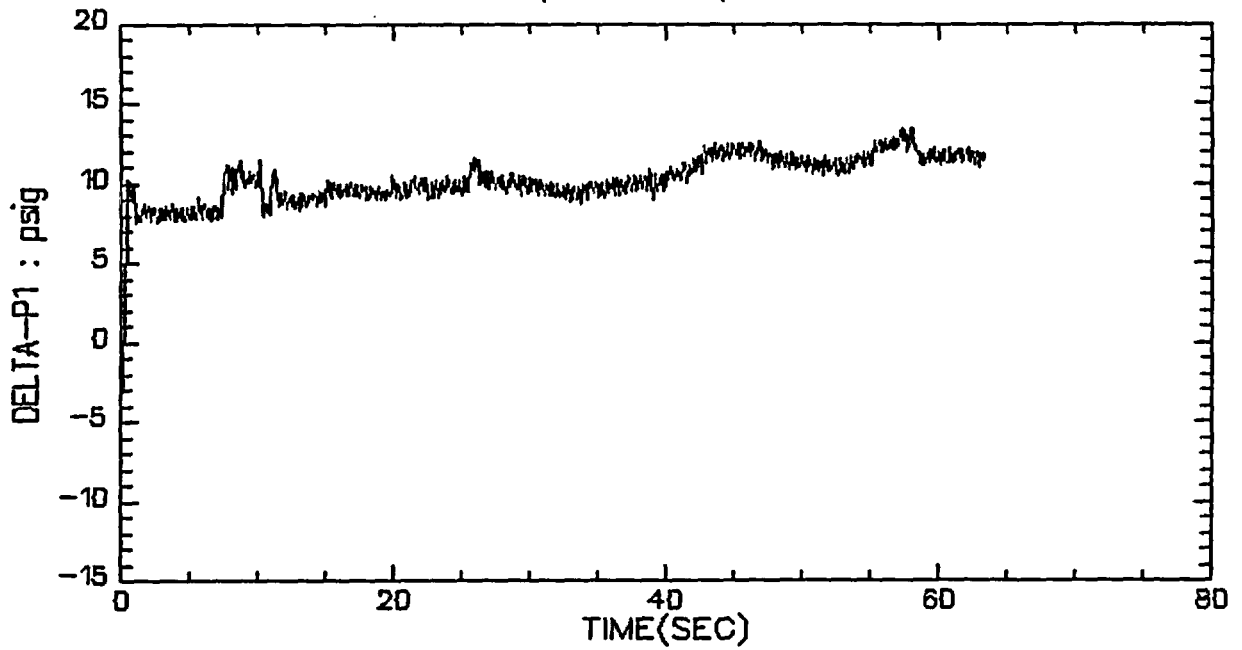

VALVE A, TEST 9, STEP 3&4

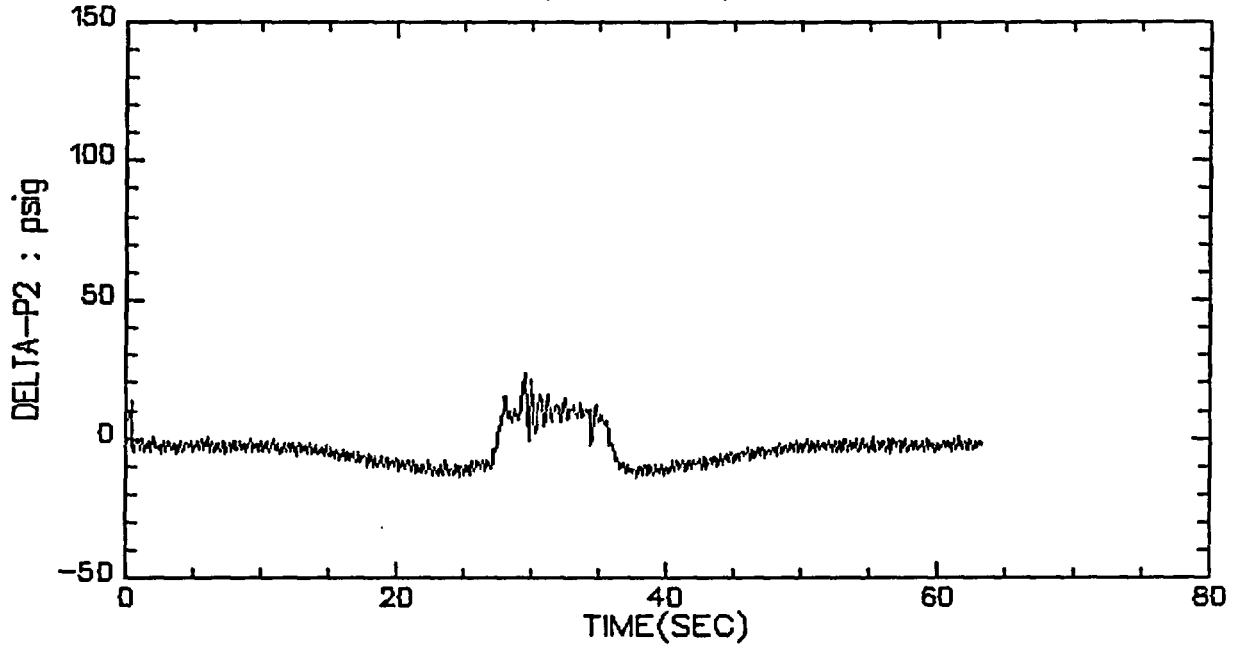

VALVE A, TEST 9, STEP 3&4

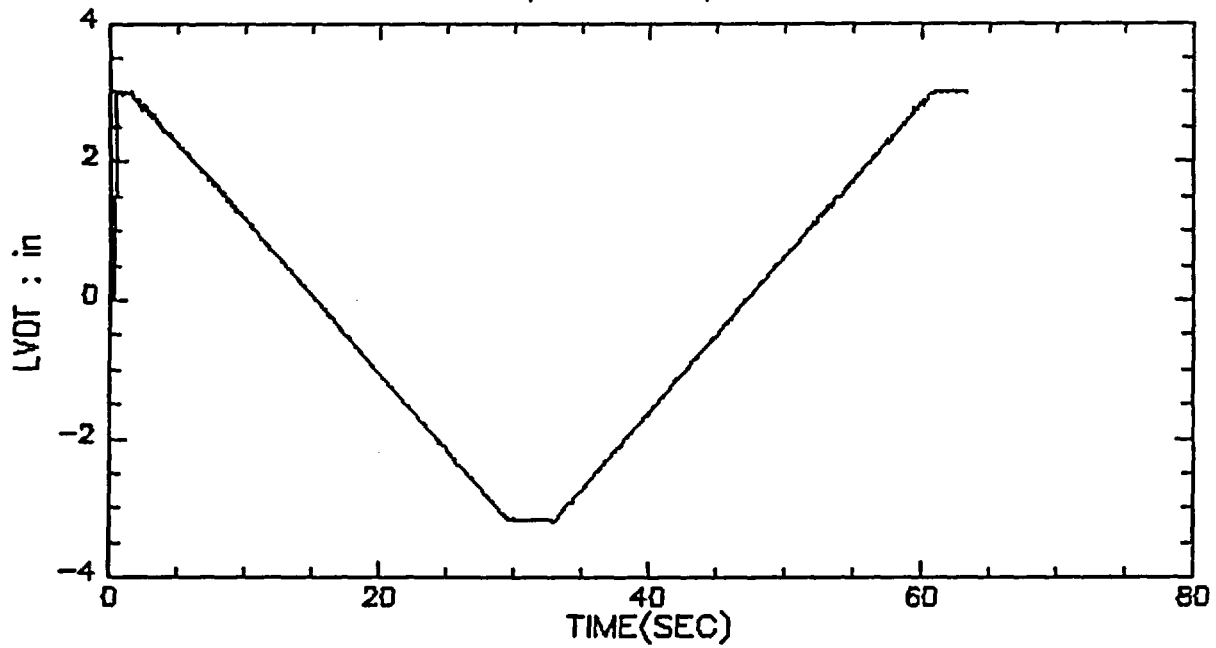

VALVE A, TEST 9, STEP 3&4

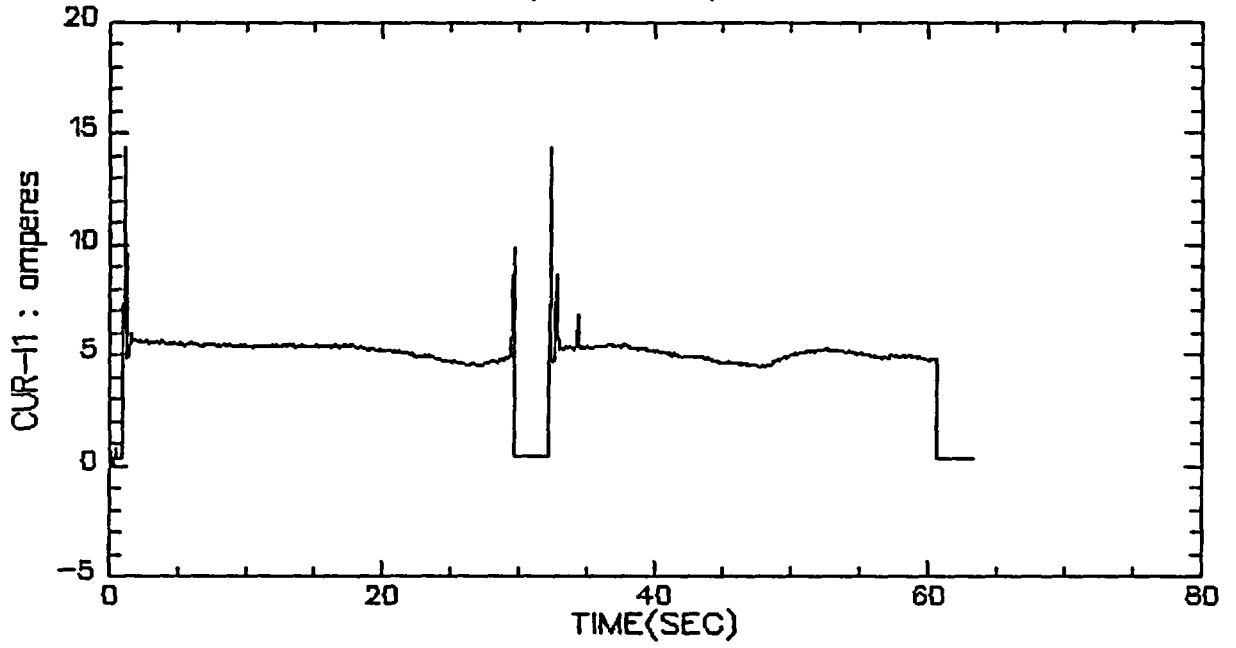

VALVE A, TEST 9, STEP 3&4

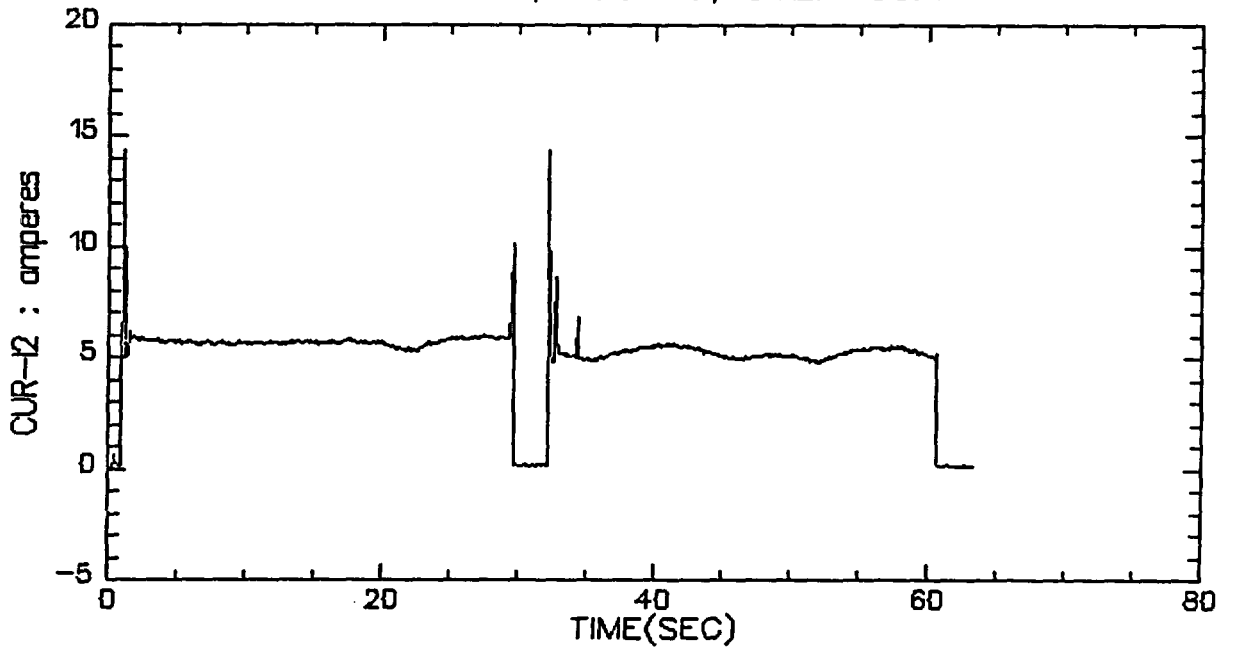

VALVE A, TEST 9, STEP 3&4

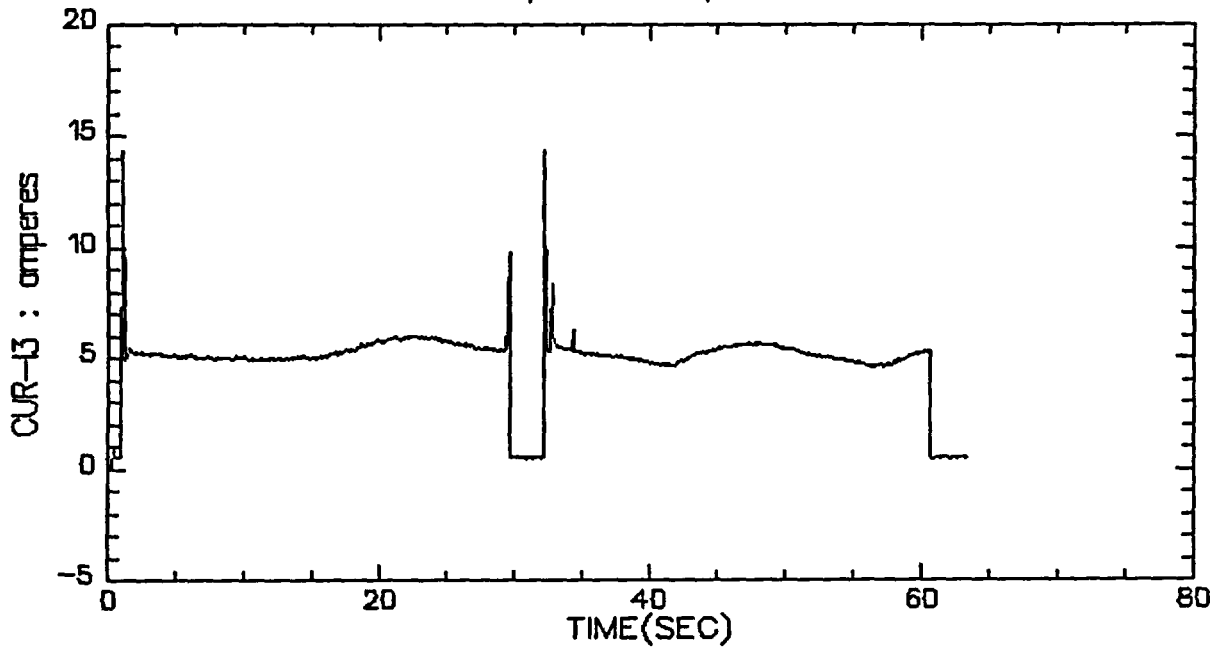

VALVE A, TEST 9, STEP 3&4

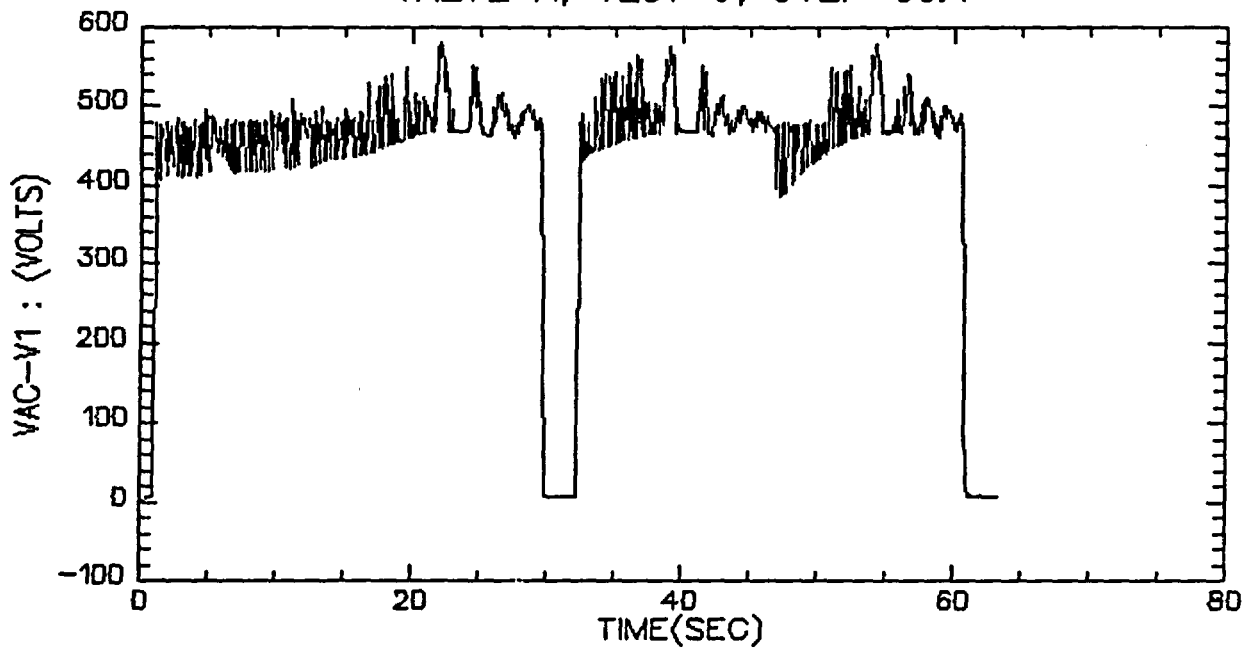

VALVE A, TEST 9, STEP 3&4

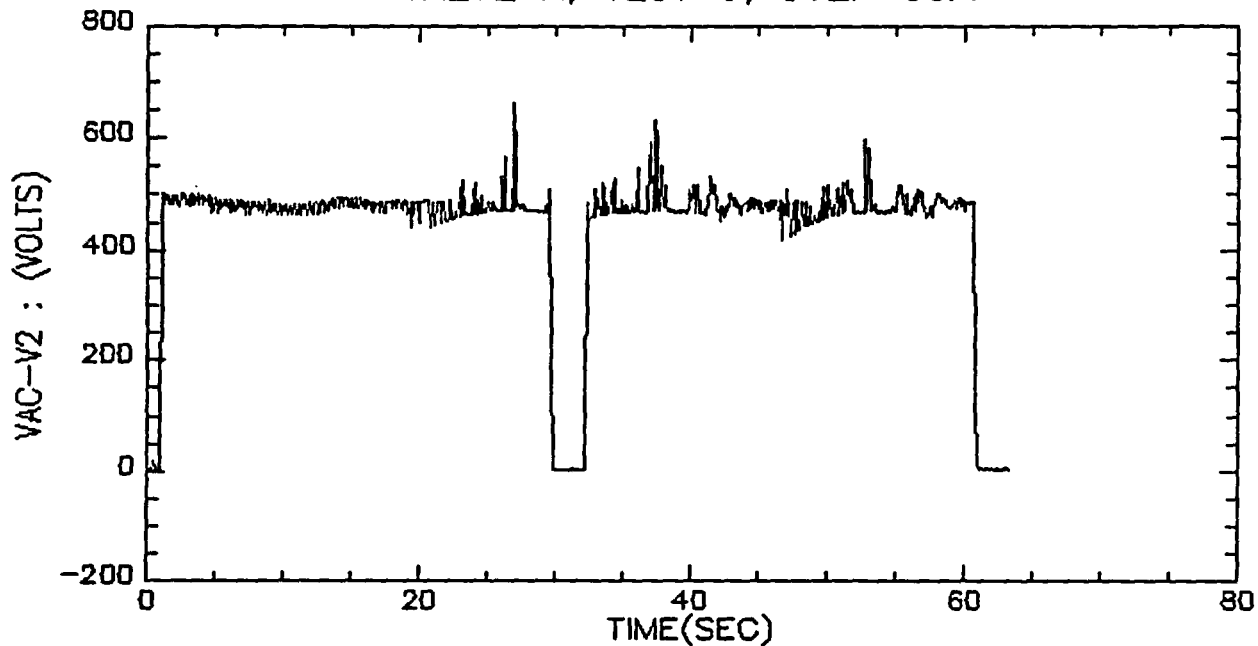

VALVE A, TEST 9, STEP 3&4

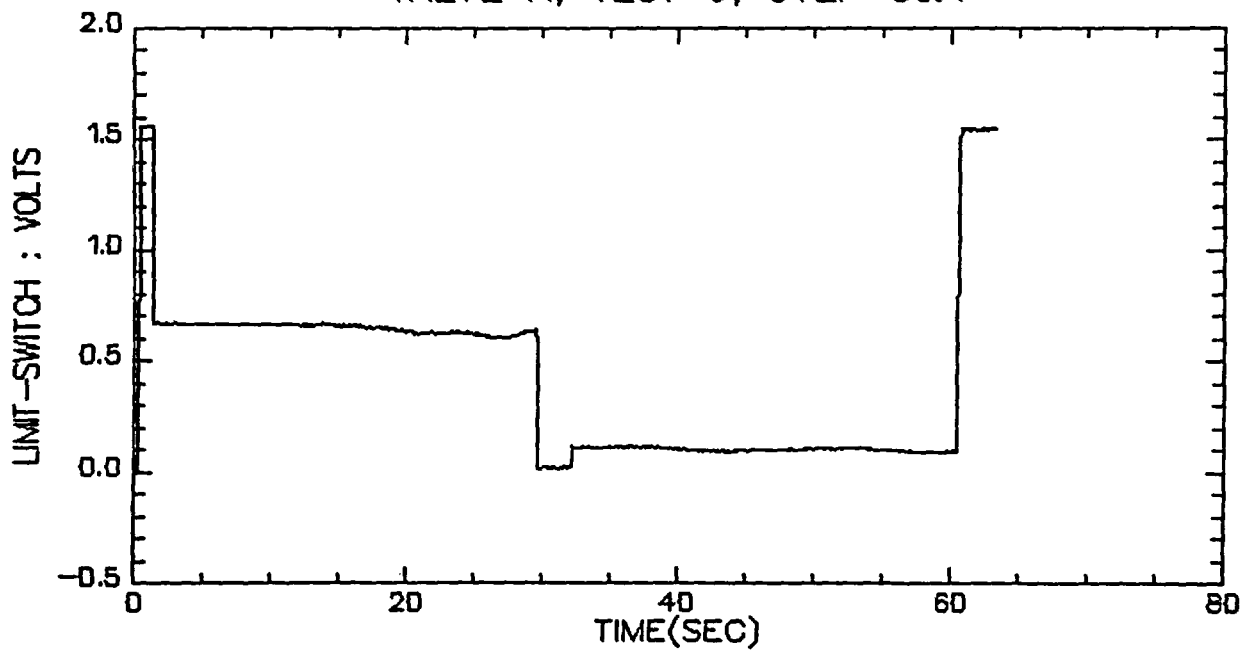

VALVE A, TEST 9, STEP 3&4

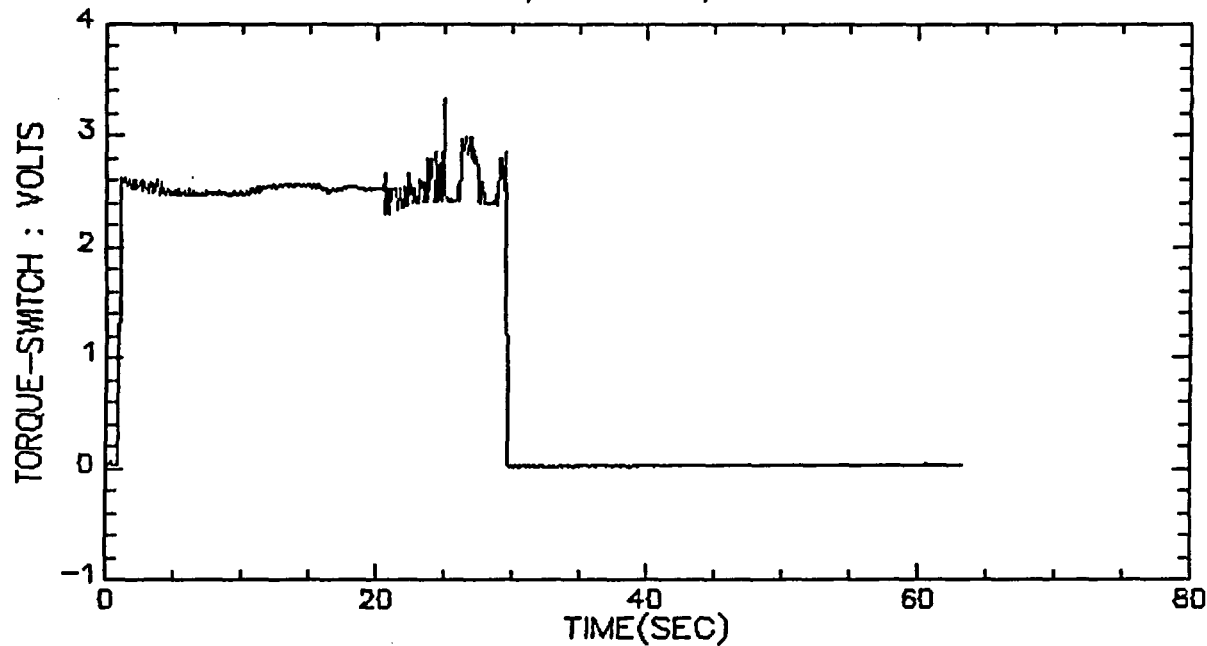

VALVE A, TEST 9, STEP 3&4

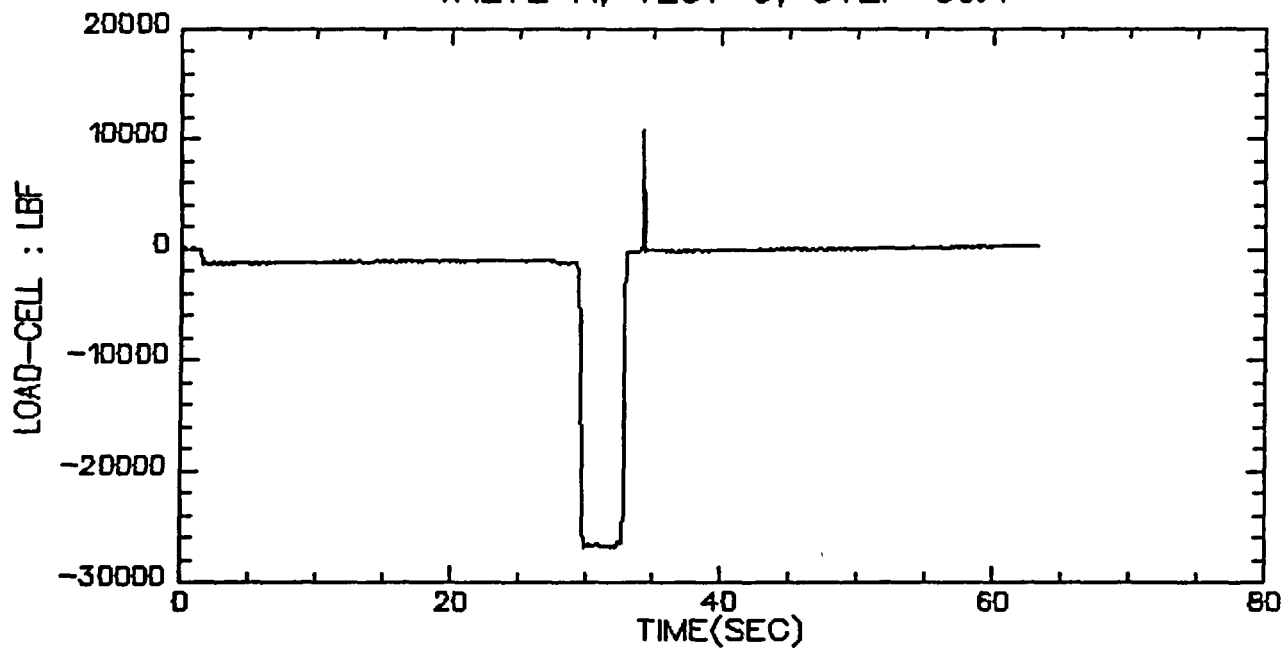

VALVE A, TEST 9, STEP 5

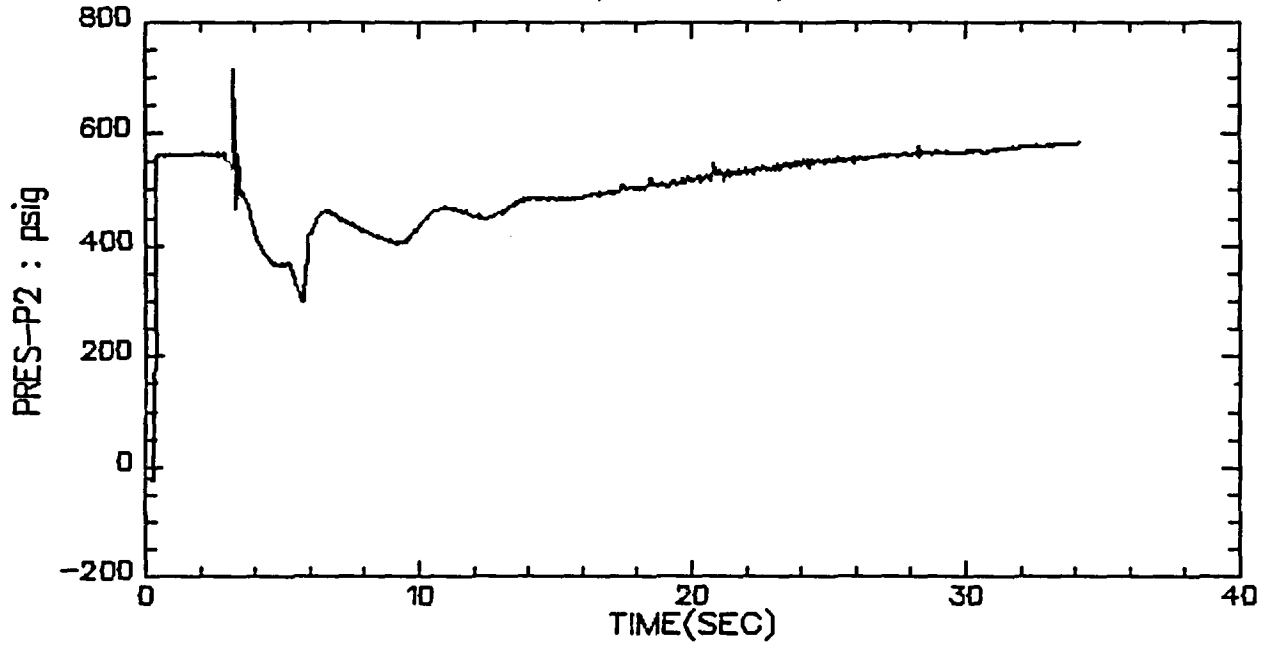

VALVE A, TEST 9, STEP 5

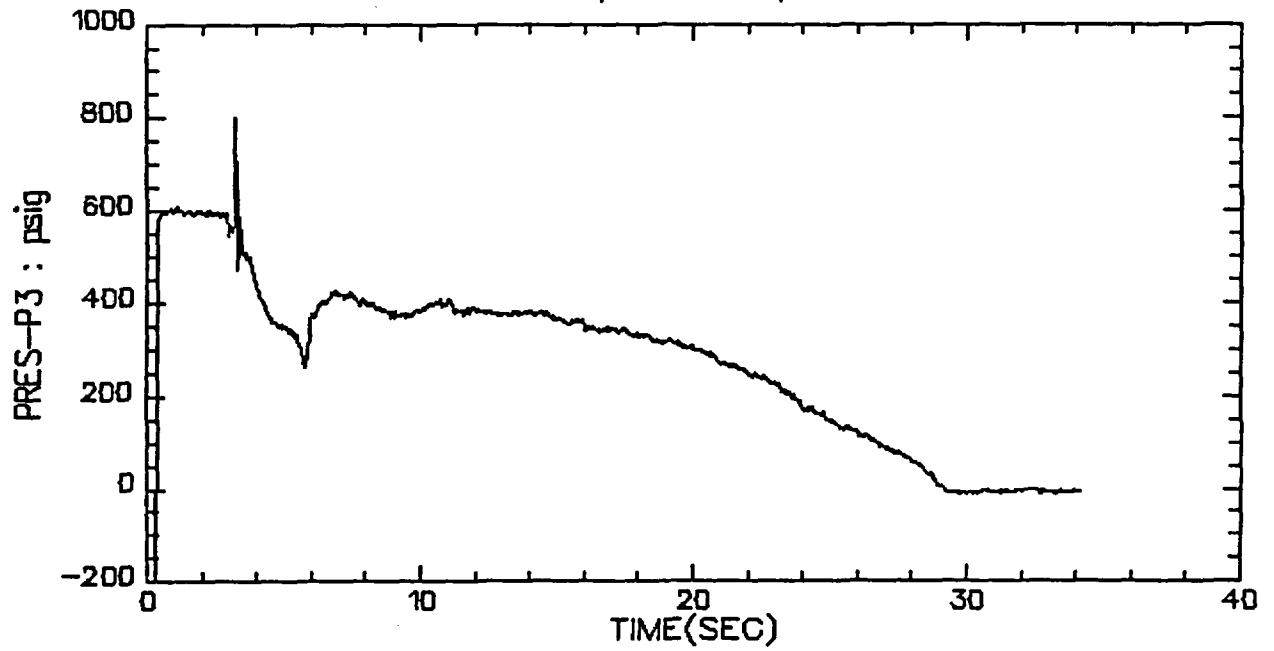

VALVE A, TEST 9, STEP 5

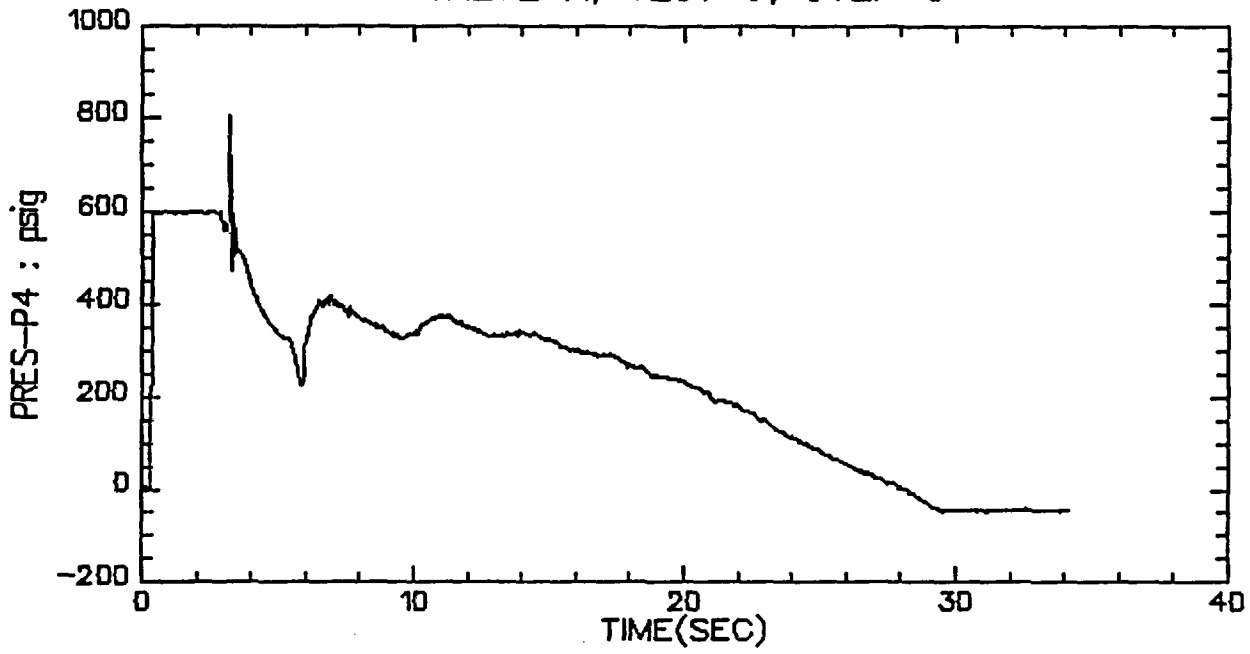

VALVE A, TEST 9, STEP 5

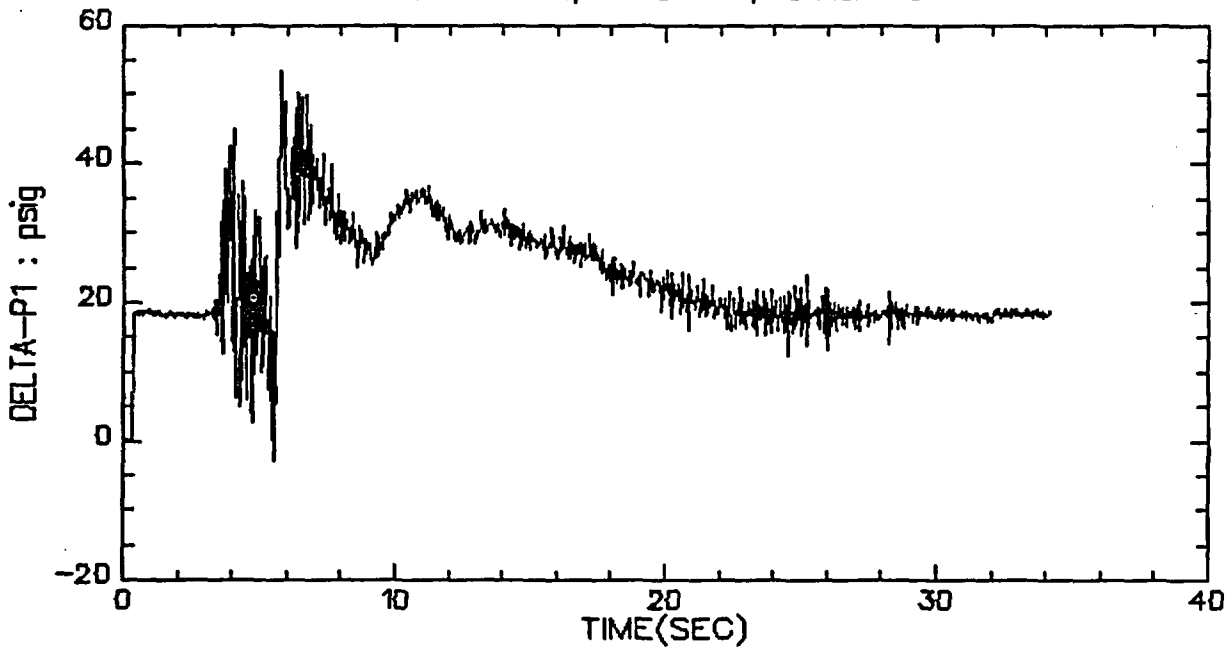

VALVE A, TEST 9, STEP 5

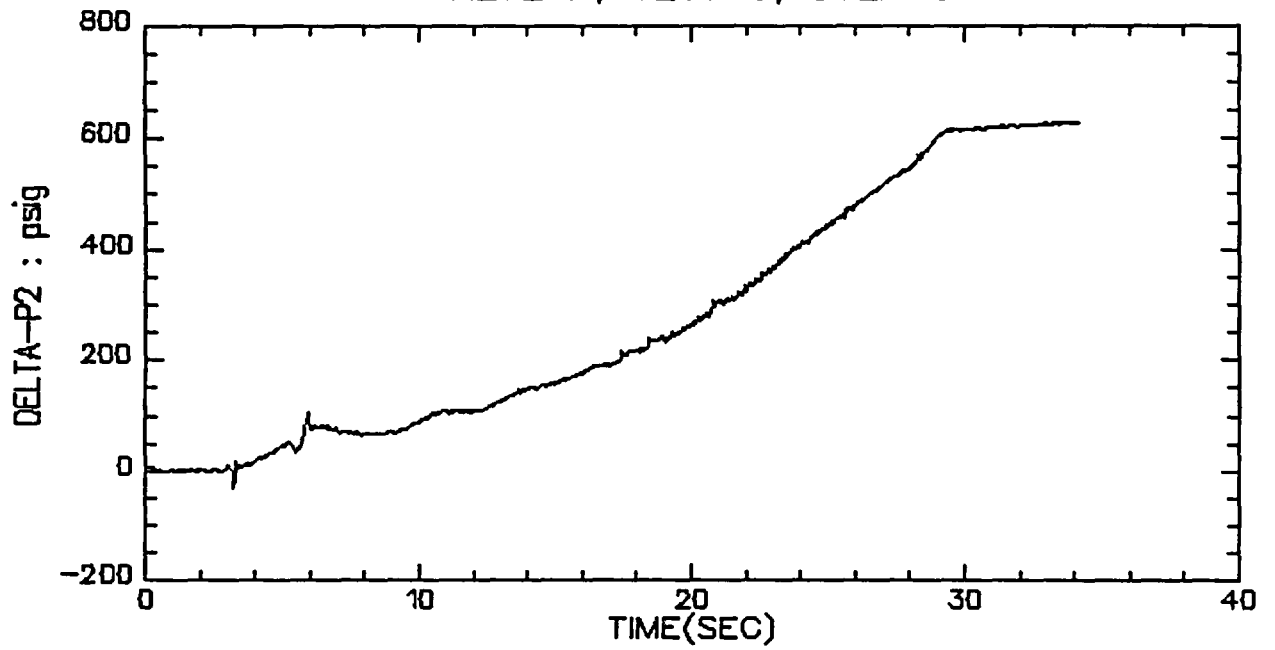

VALVE A, TEST 9, STEP 5

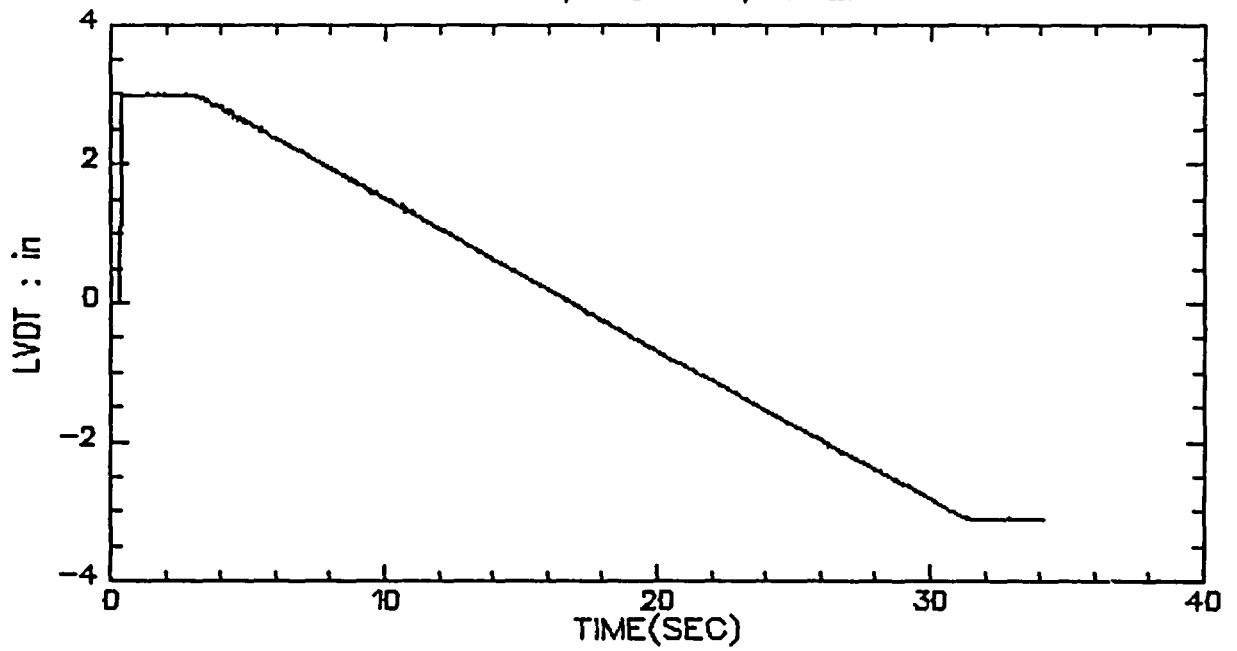

VALVE A, TEST 9, STEP 5

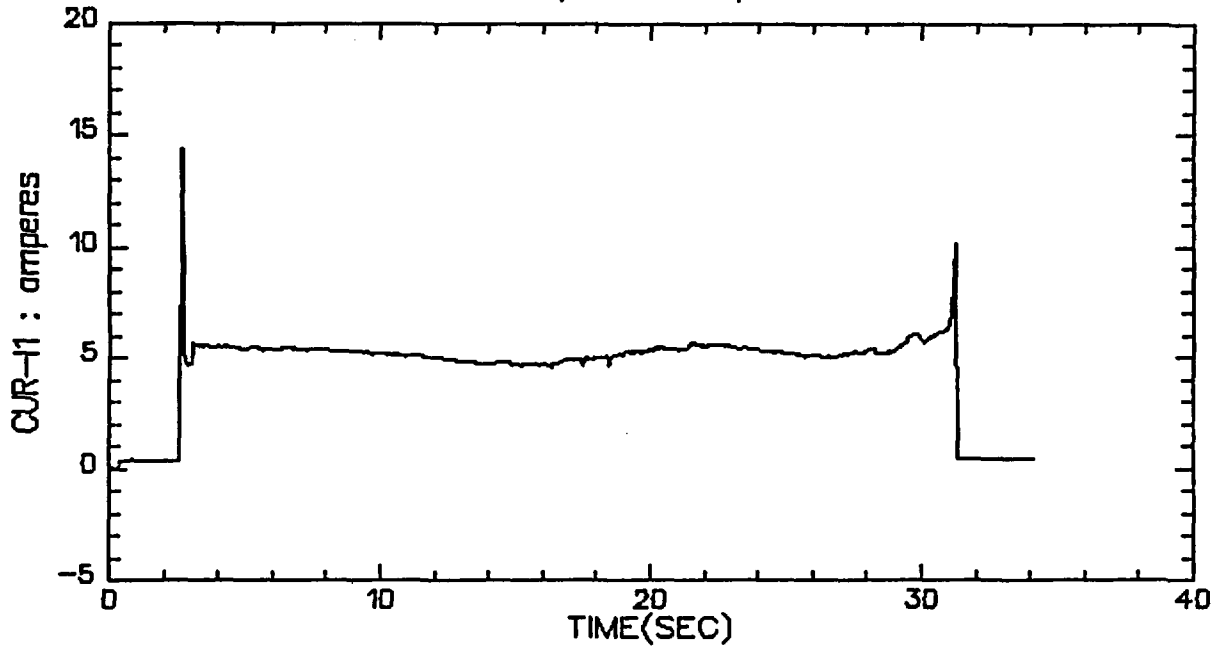

VALVE A, TEST 9, STEP 5

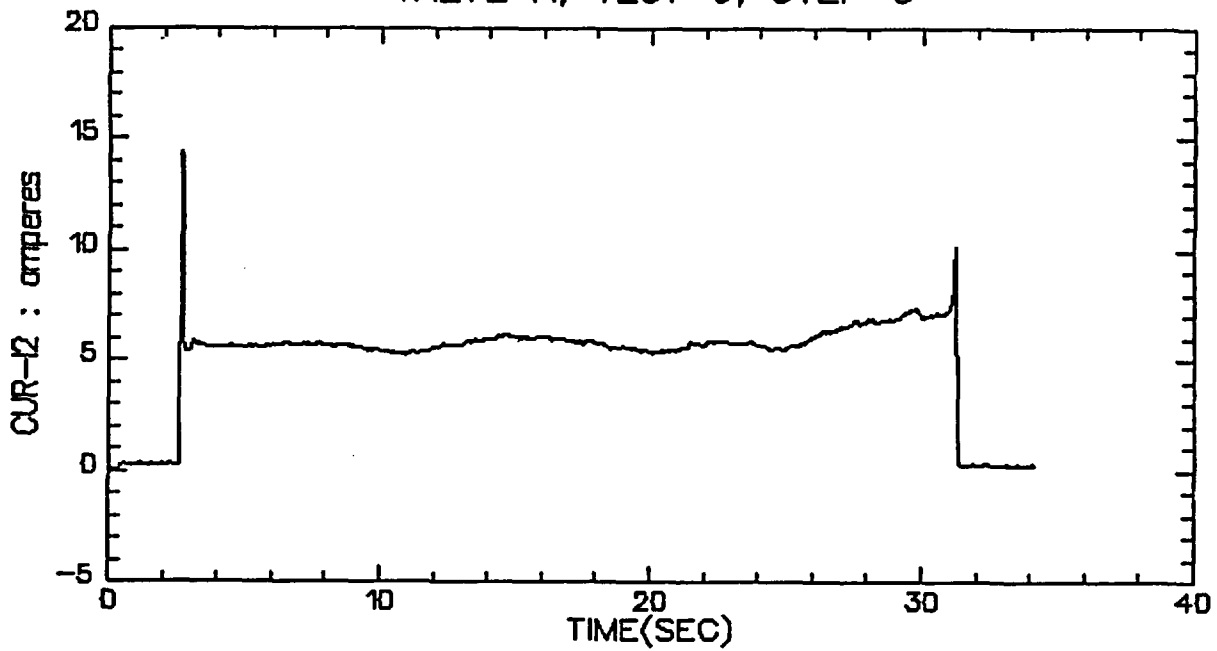

VALVE A, TEST 9, STEP 5

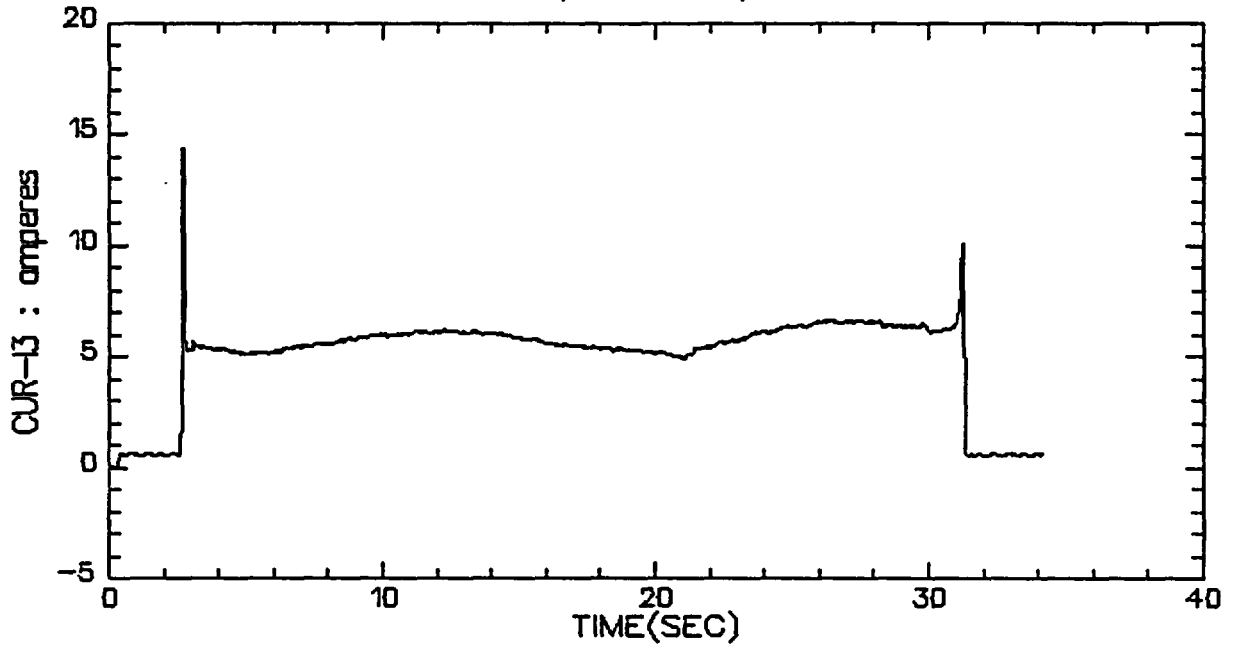

VALVE A, TEST 9, STEP 5

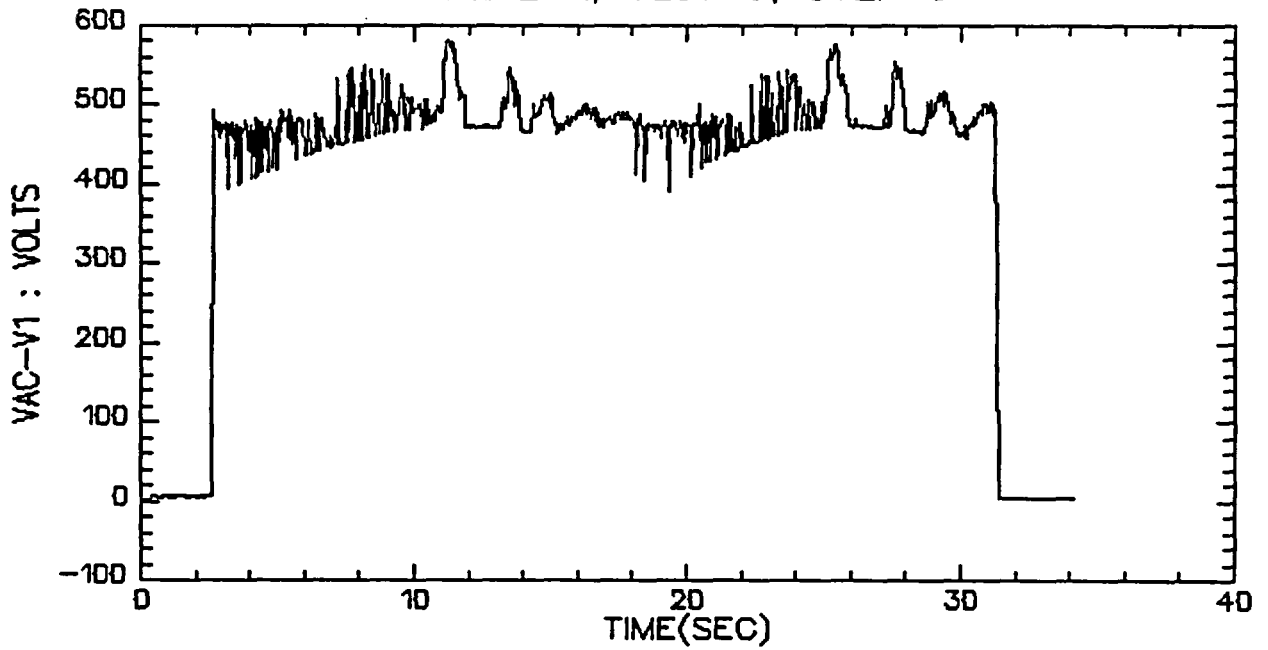

VALVE A, TEST 9, STEP 5

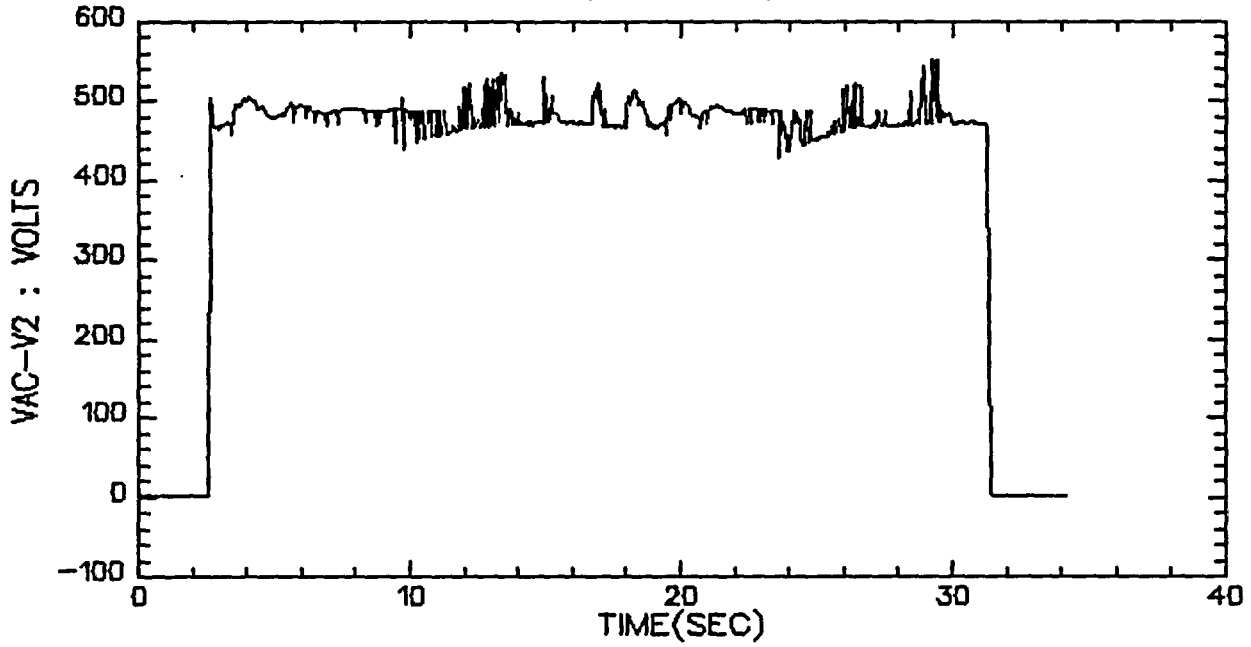

VALVE A, TEST 9, STEP 5

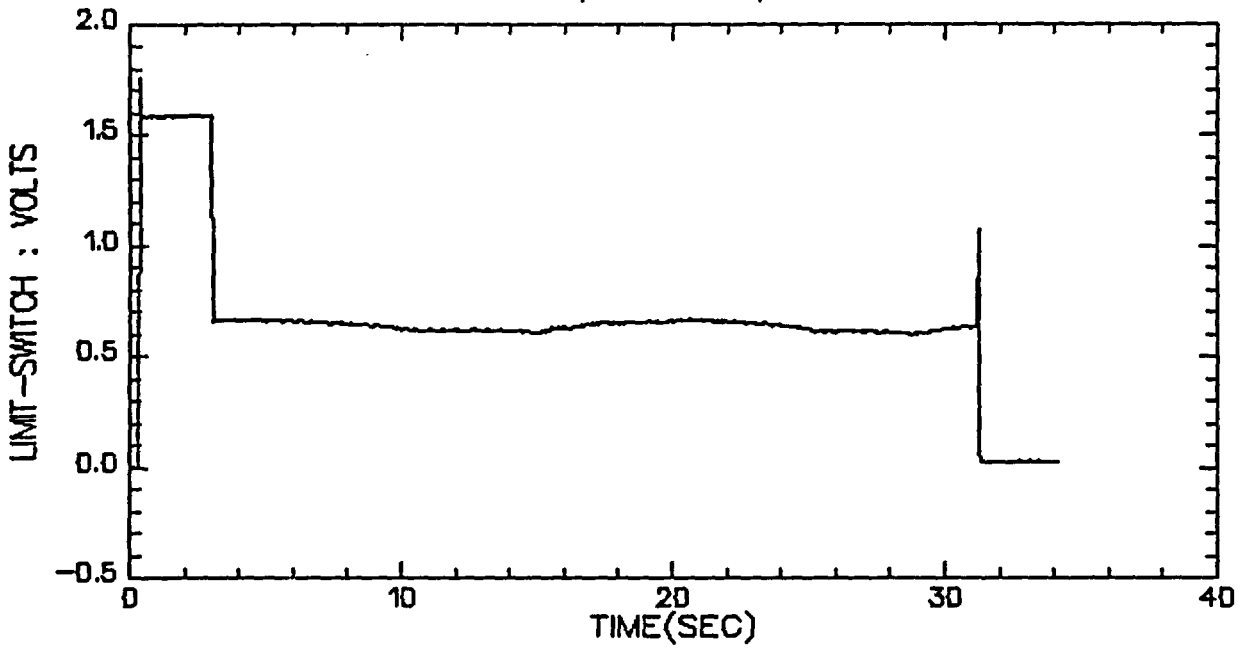

VALVE A, TEST 9, STEP 5

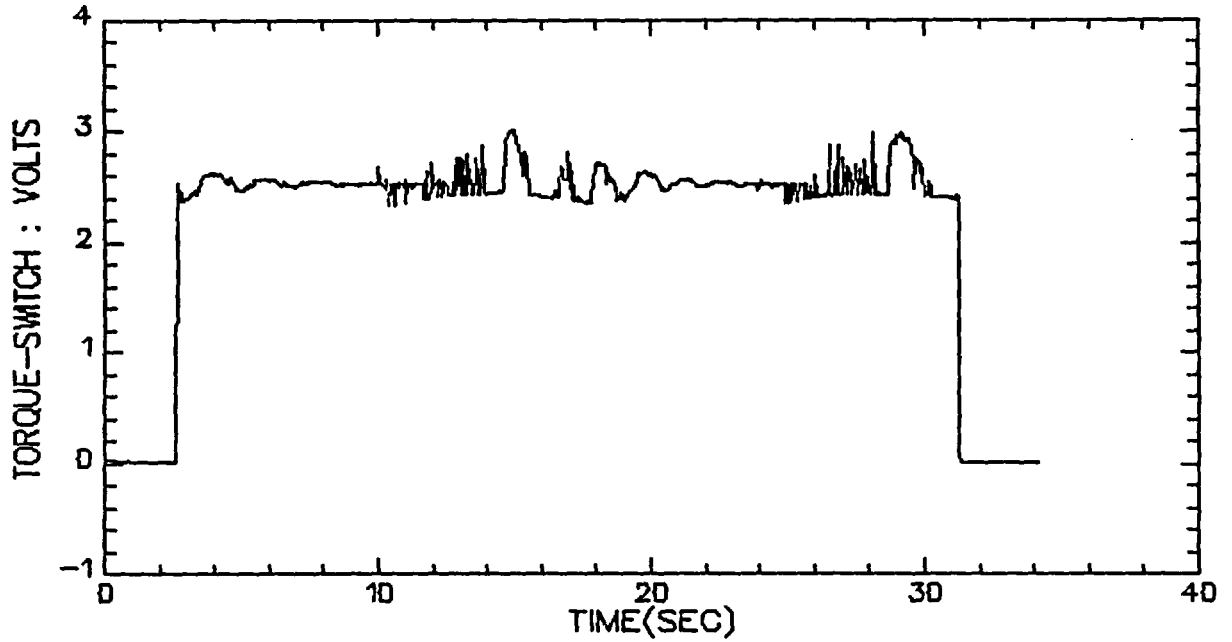

VALVE A, TEST 9, STEP 5

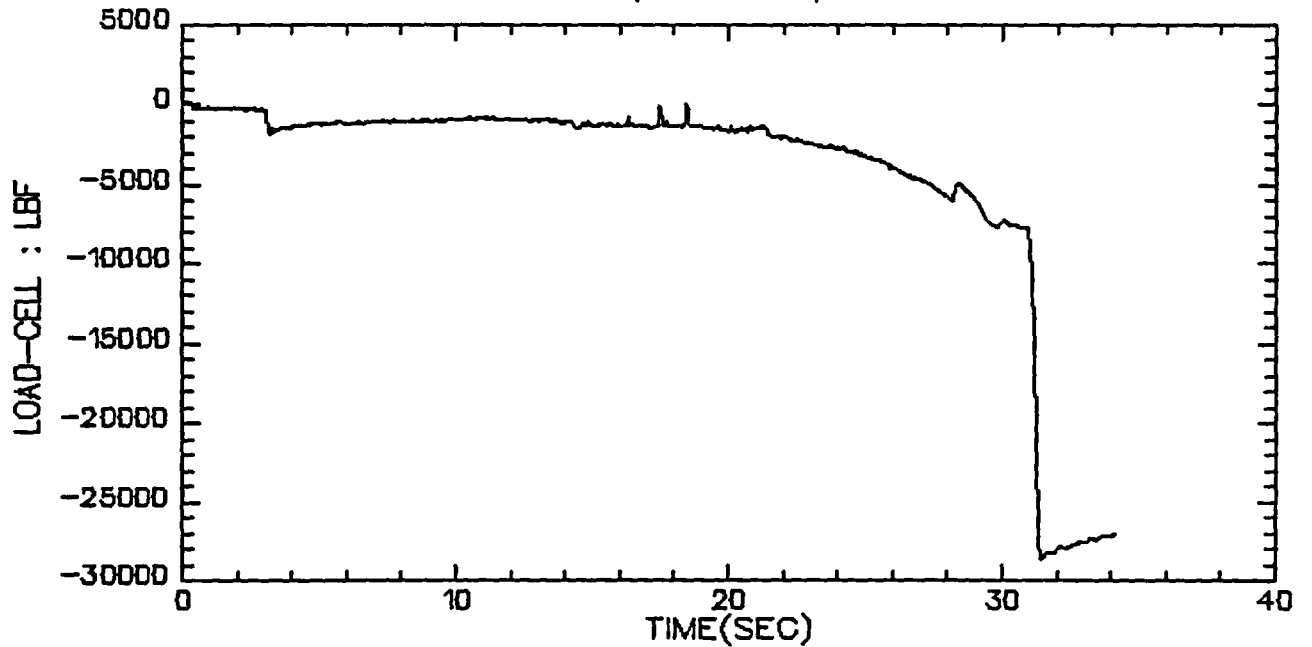

VALVE A, TEST 9, STEP 8&9

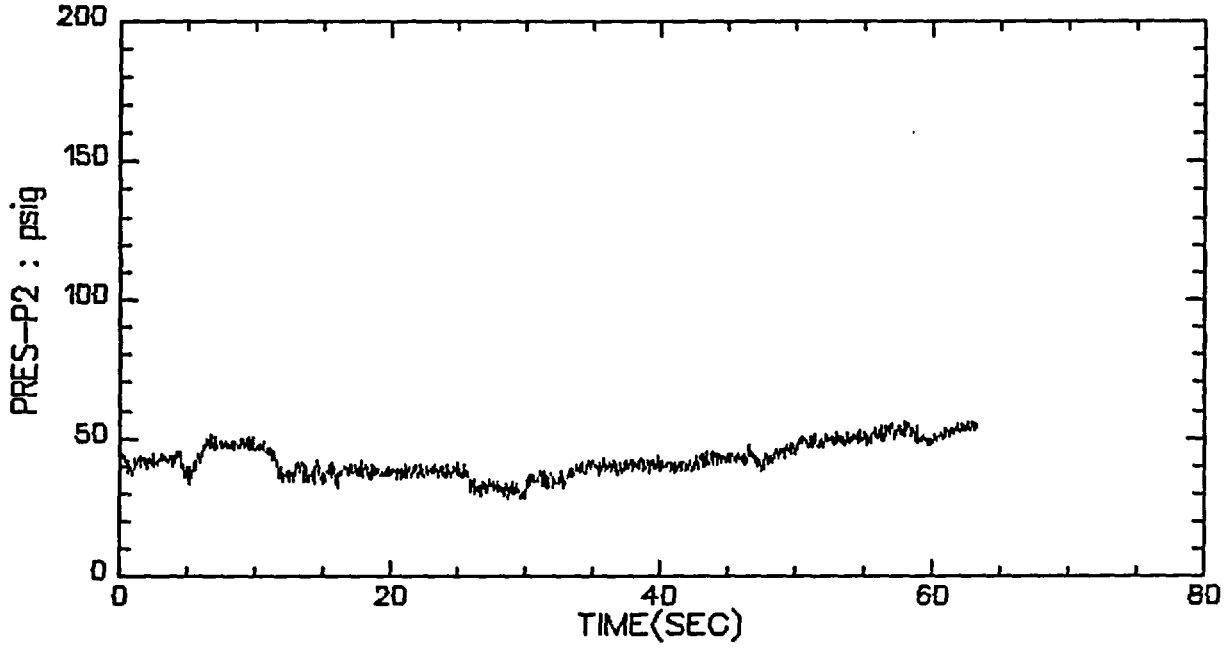

VALVE A, TEST 9, STEP 8&9

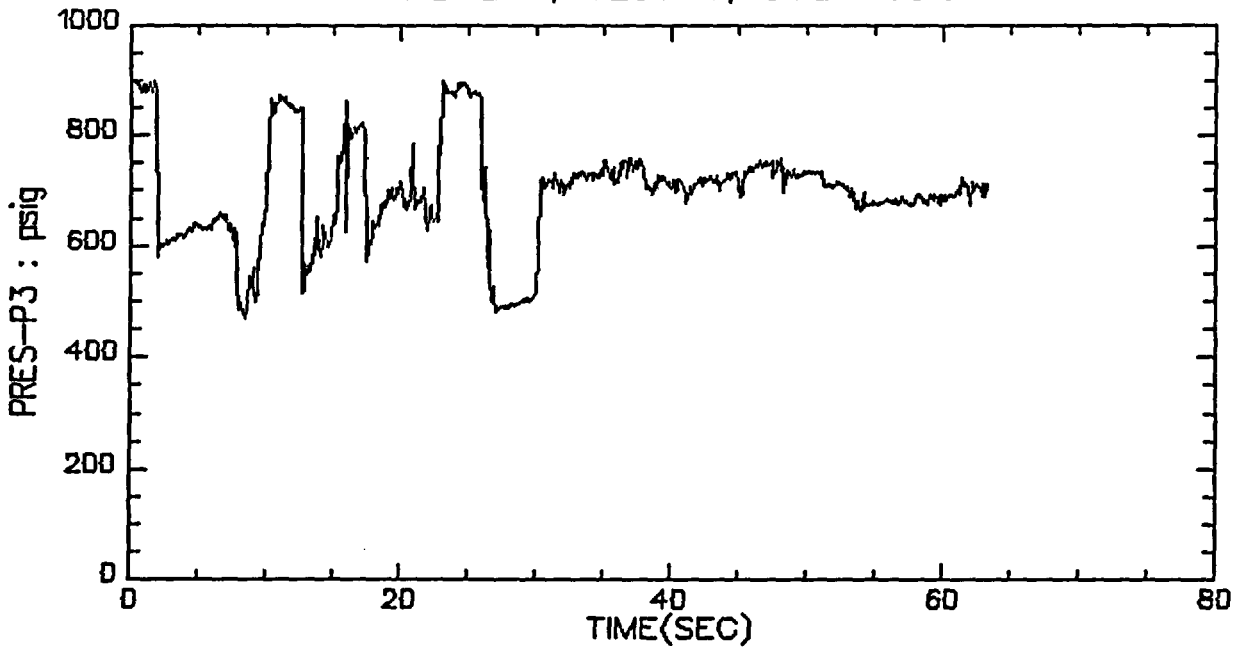

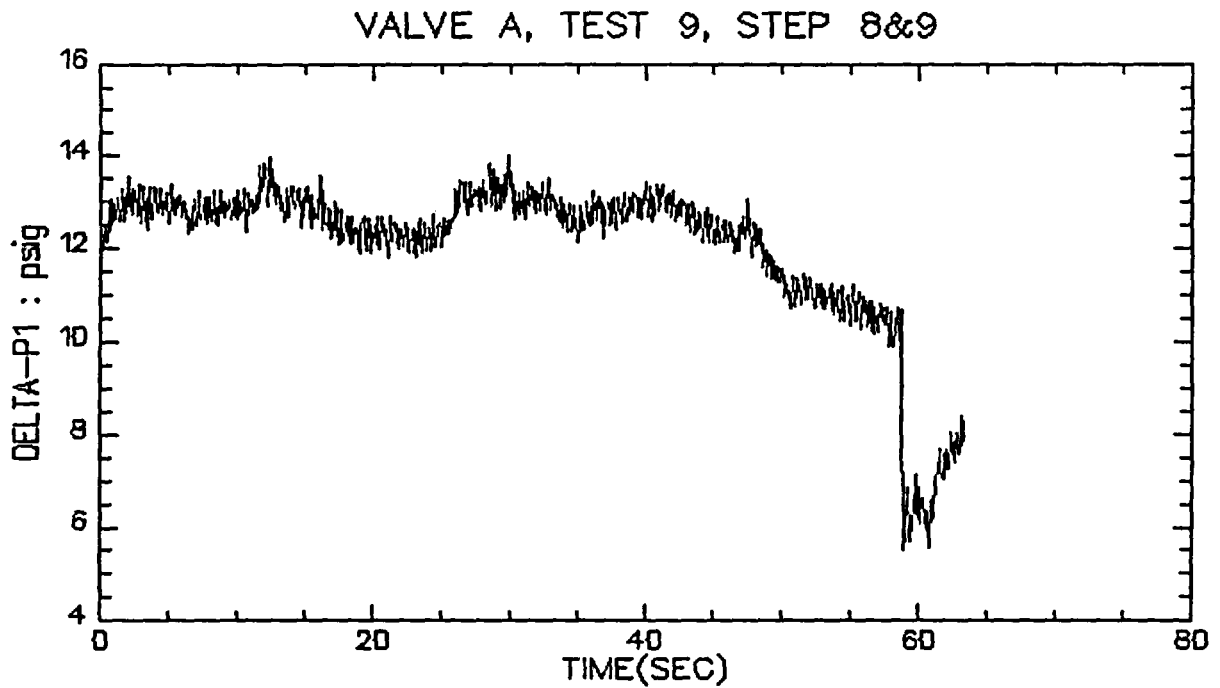
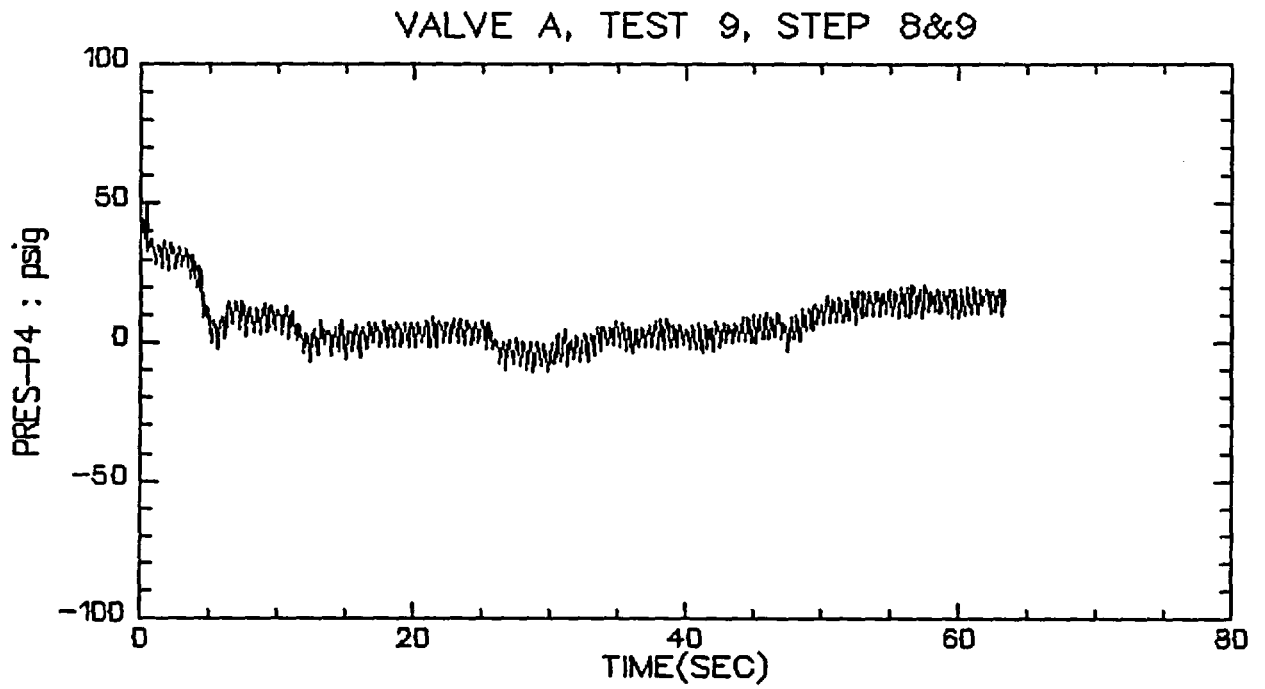

VALVE A, TEST 9, STEP 8&9

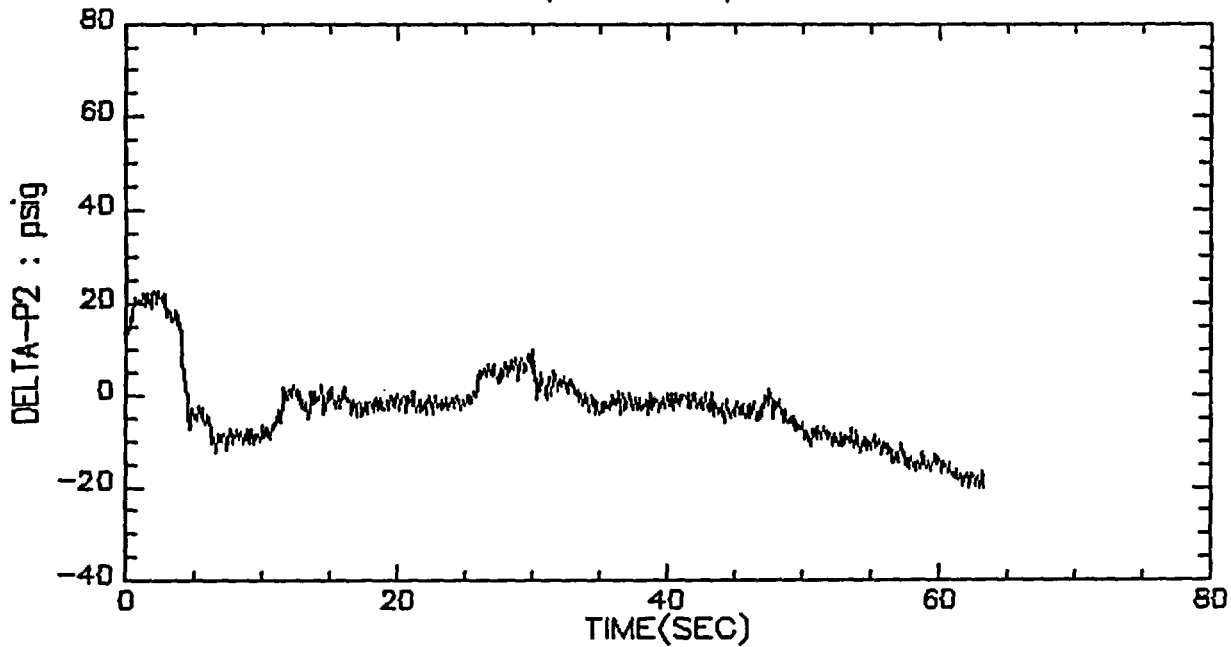

VALVE A, TEST 9, STEP 8&9

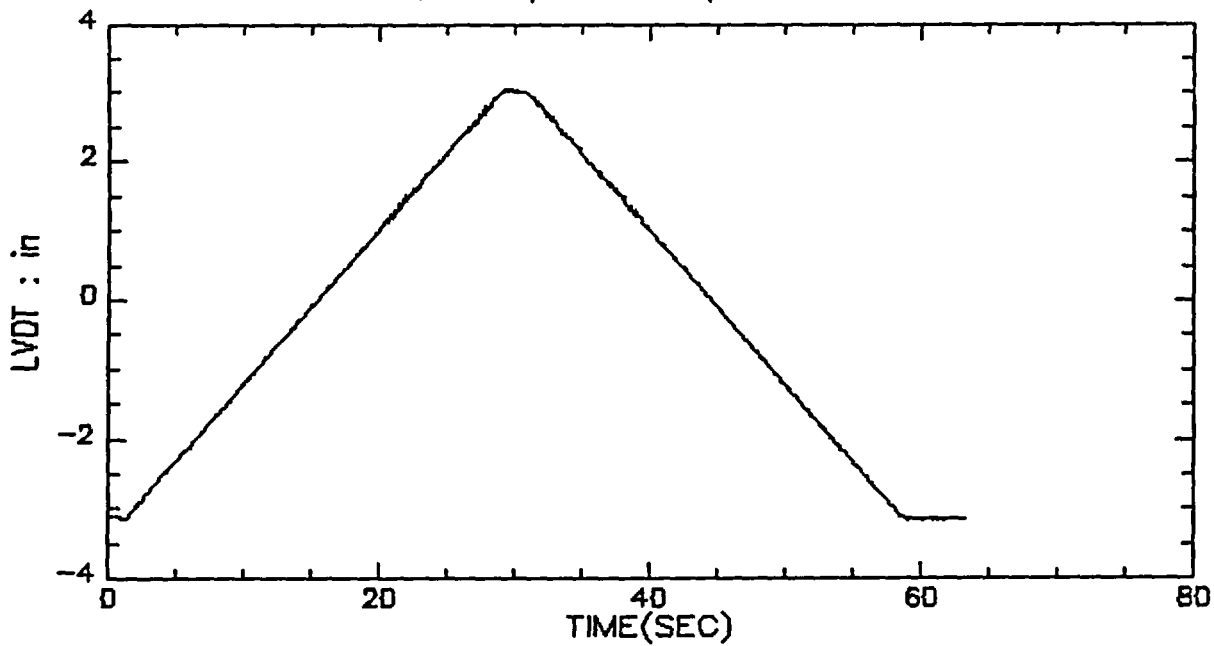

VALVE A, TEST 9, STEP 8&9

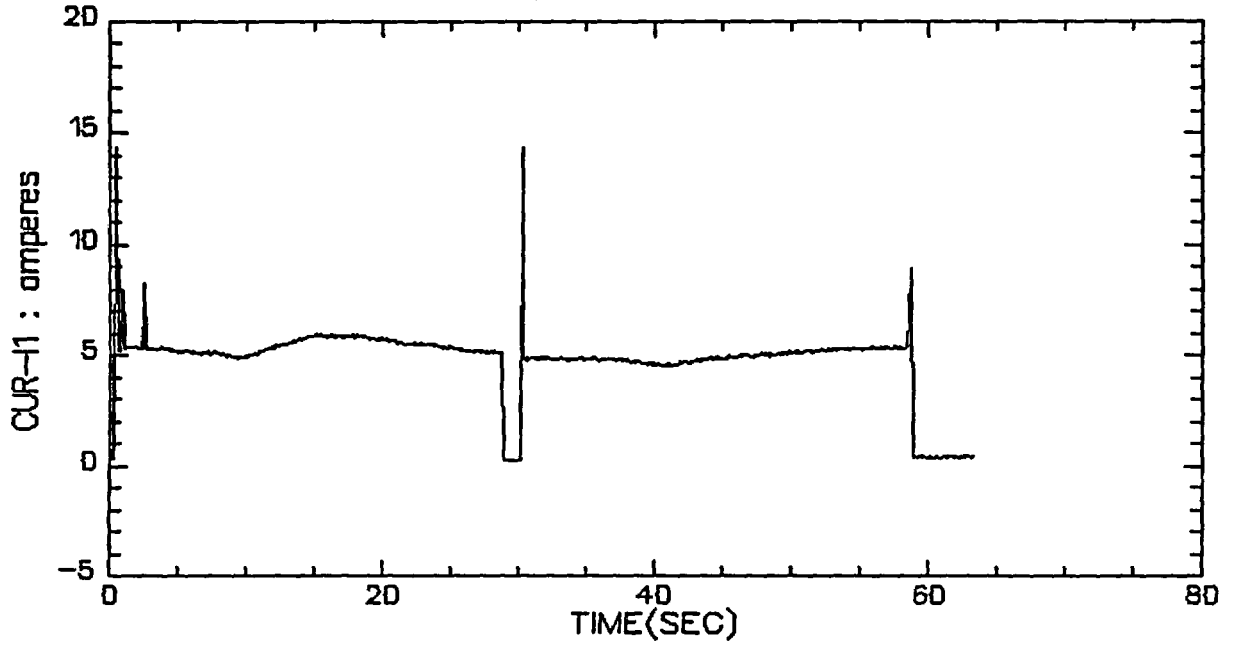

VALVE A, TEST 9, STEP 8&9

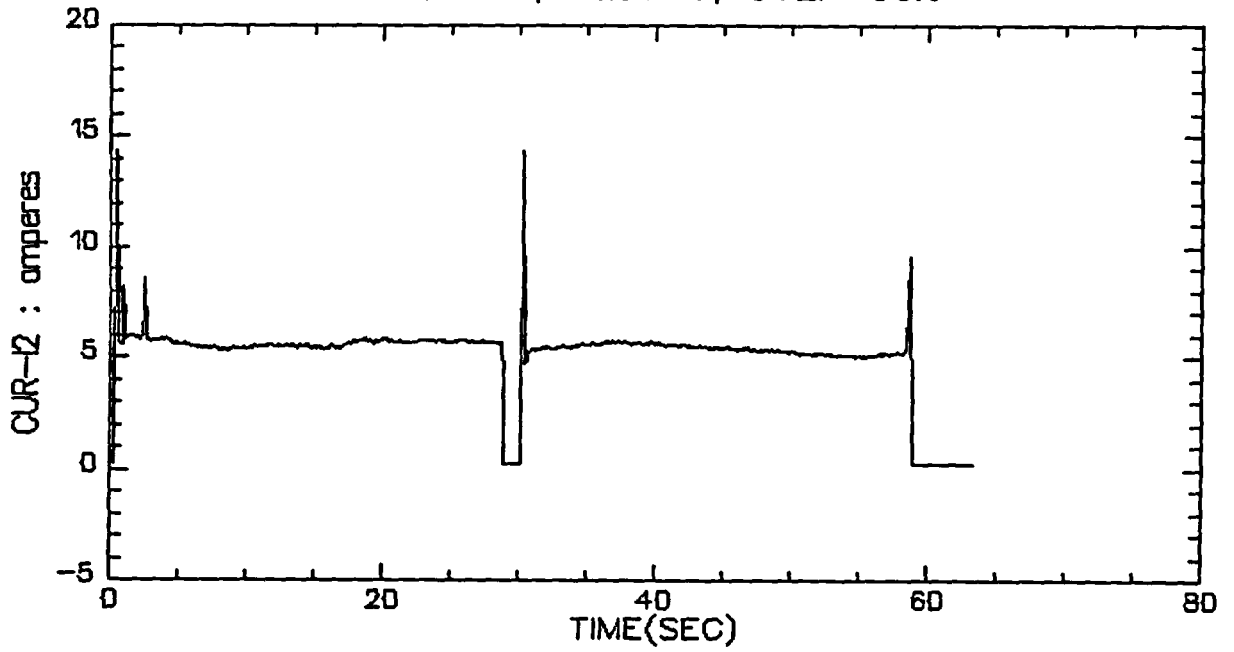

VALVE A, TEST 9, STEP 8&9

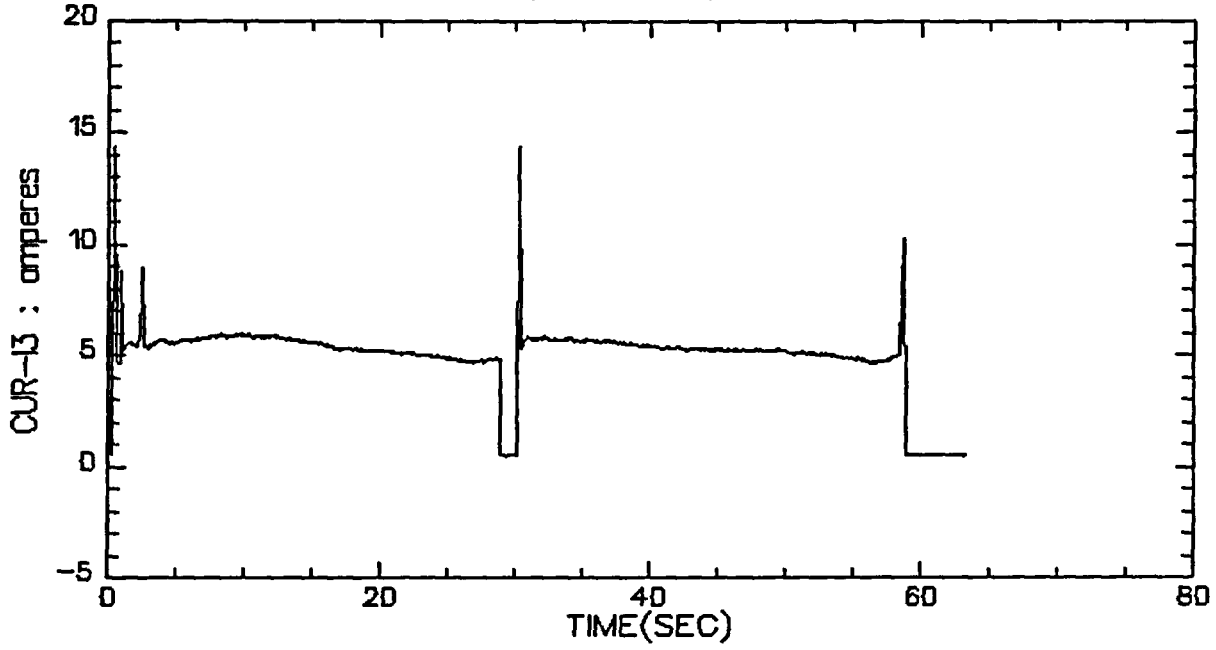

VALVE A, TEST 9, STEP 8&9

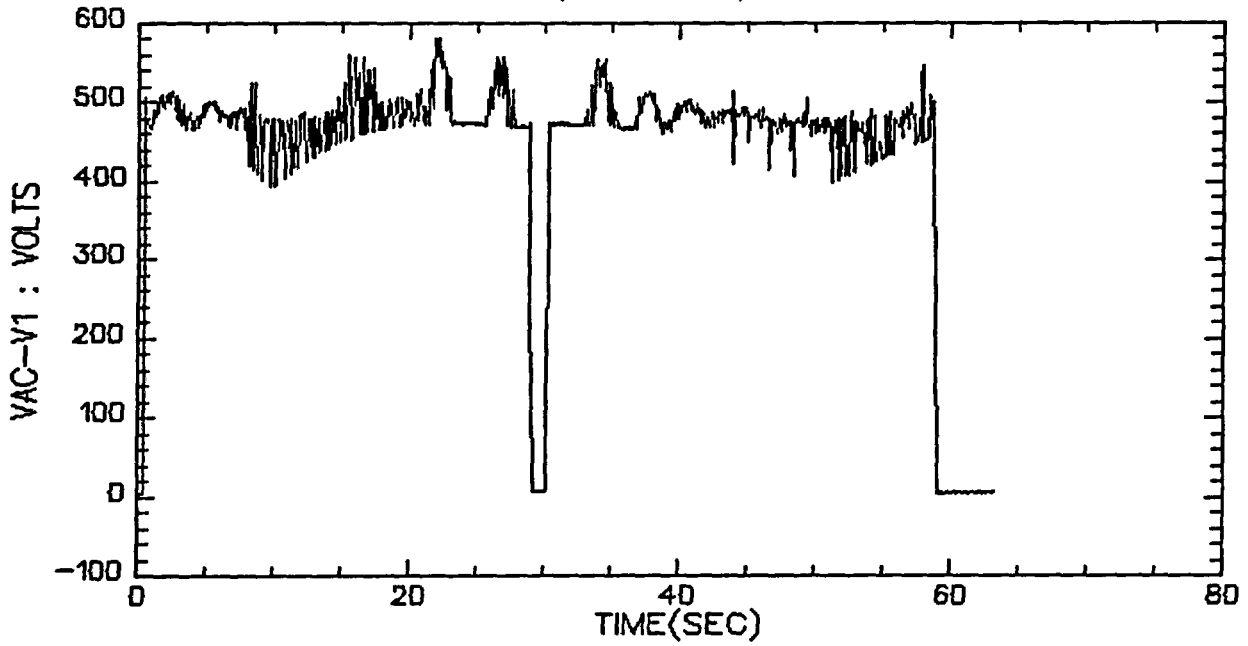

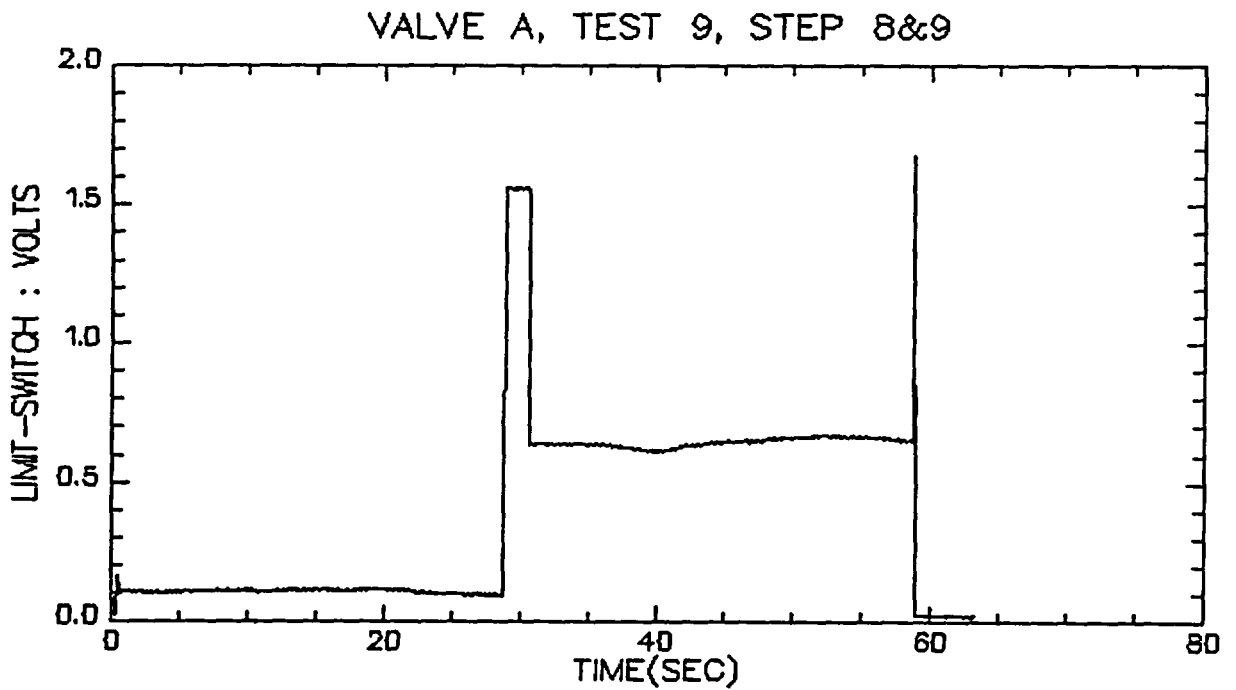
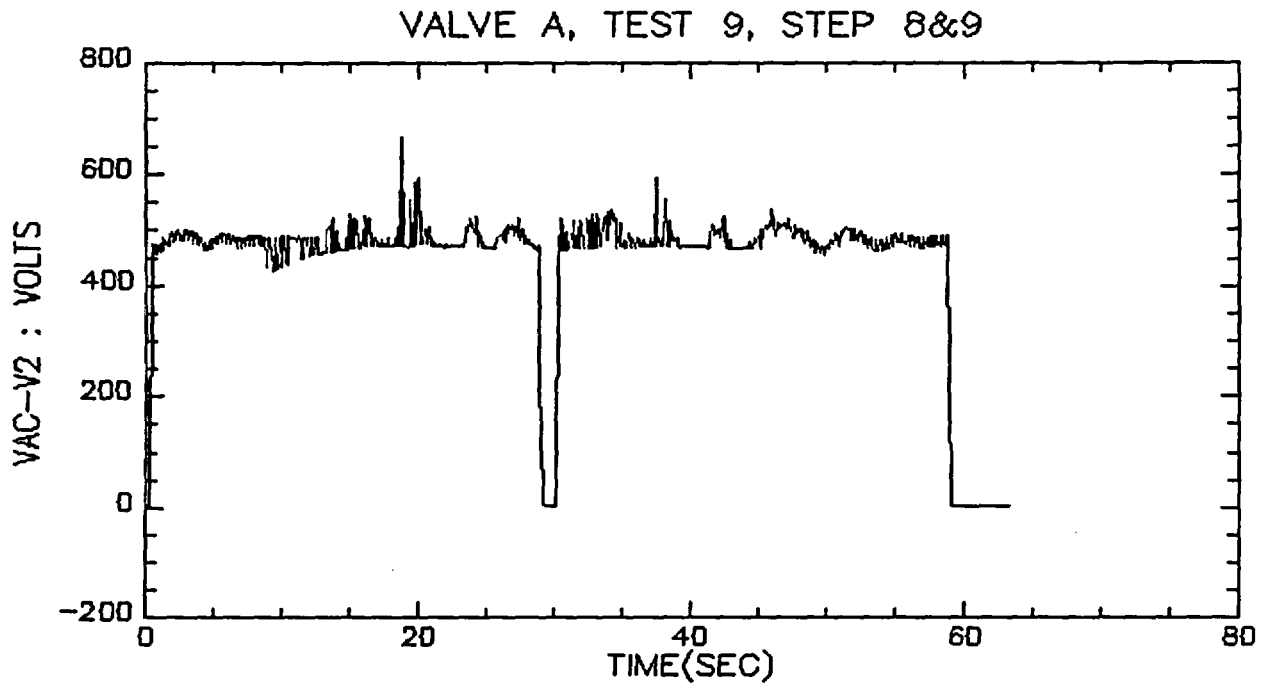

VALVE A, TEST 9, STEP 8&9

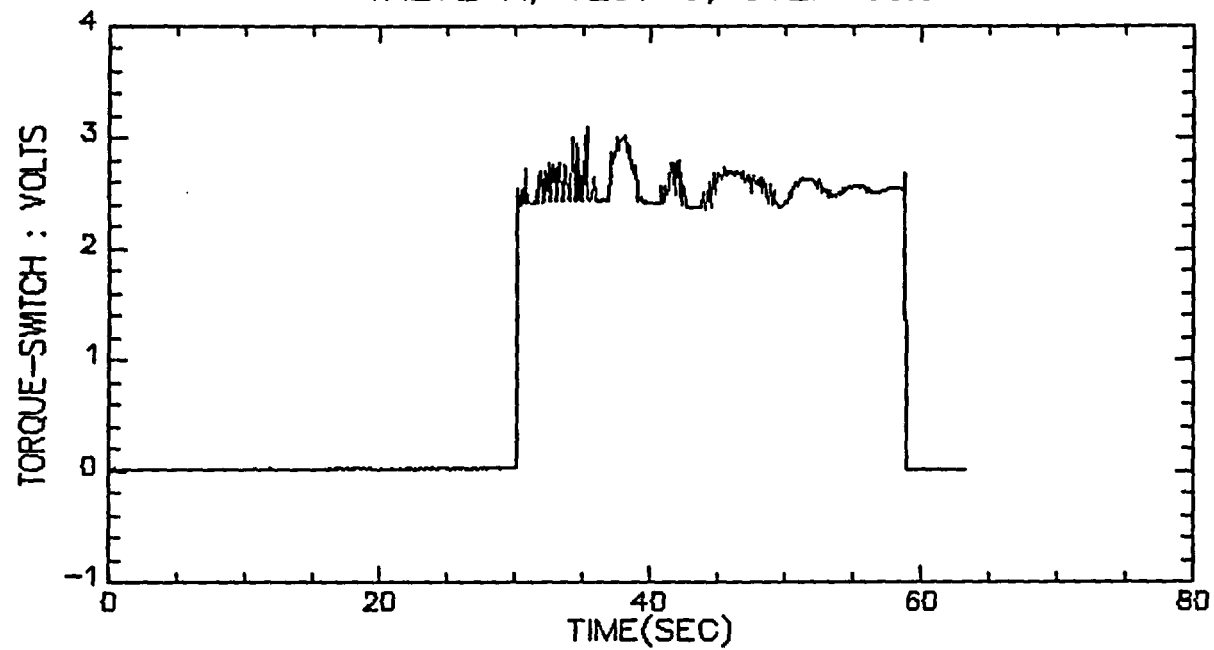

VALVE A, TEST 9, STEP 8&9

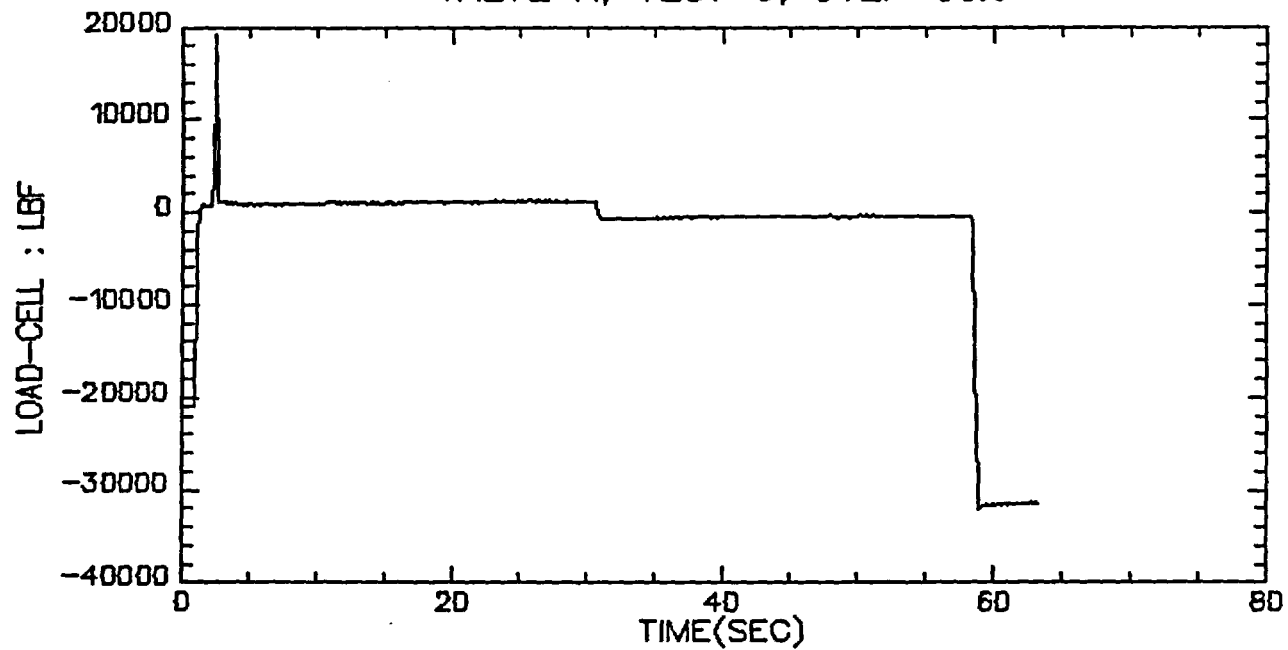

VALVE A, TEST 10, STEP 1

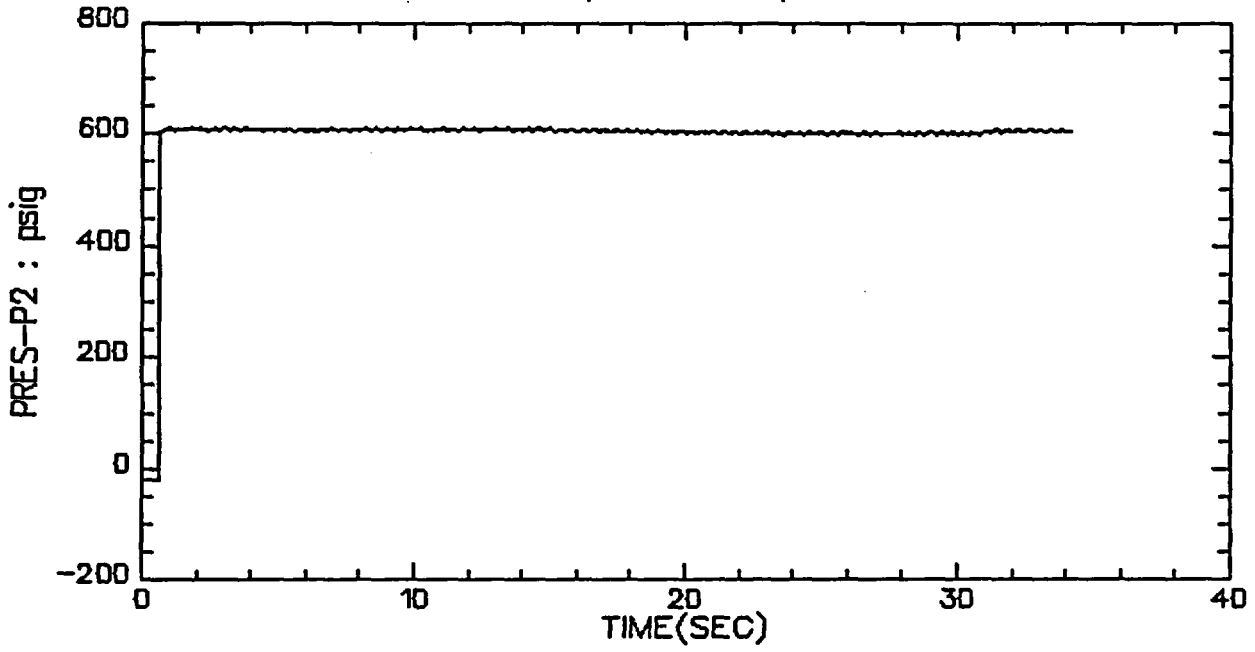

VALVE A, TEST 10, STEP 1

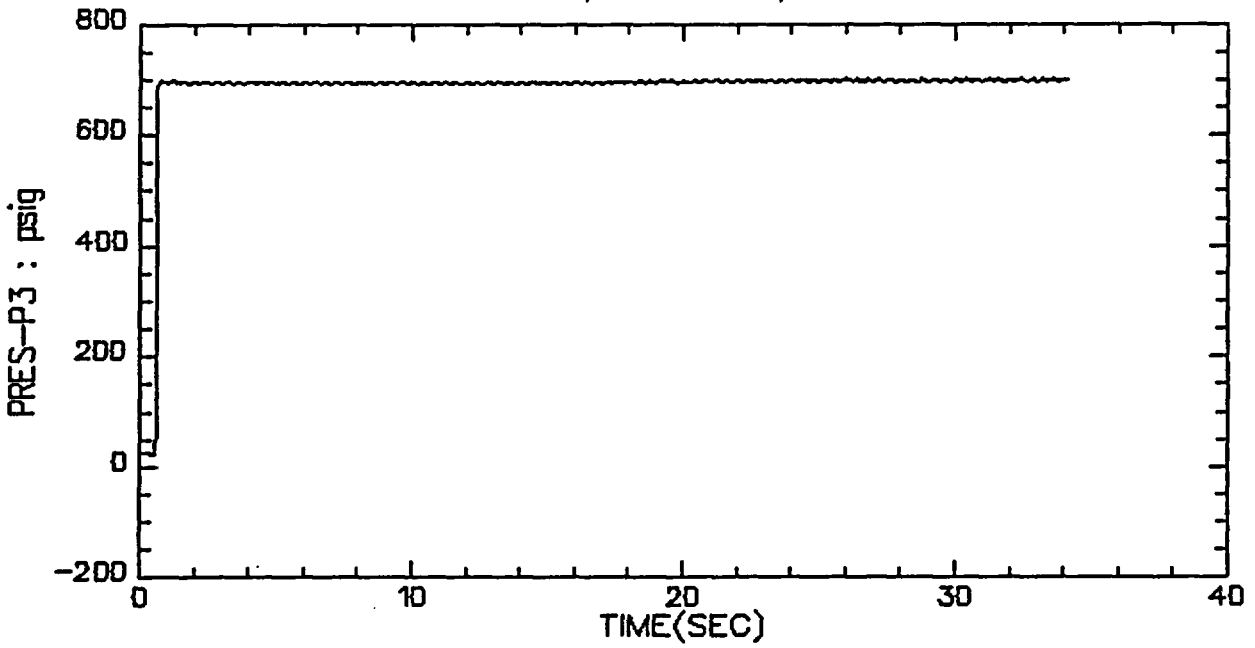

VALVE A, TEST 10, STEP 1

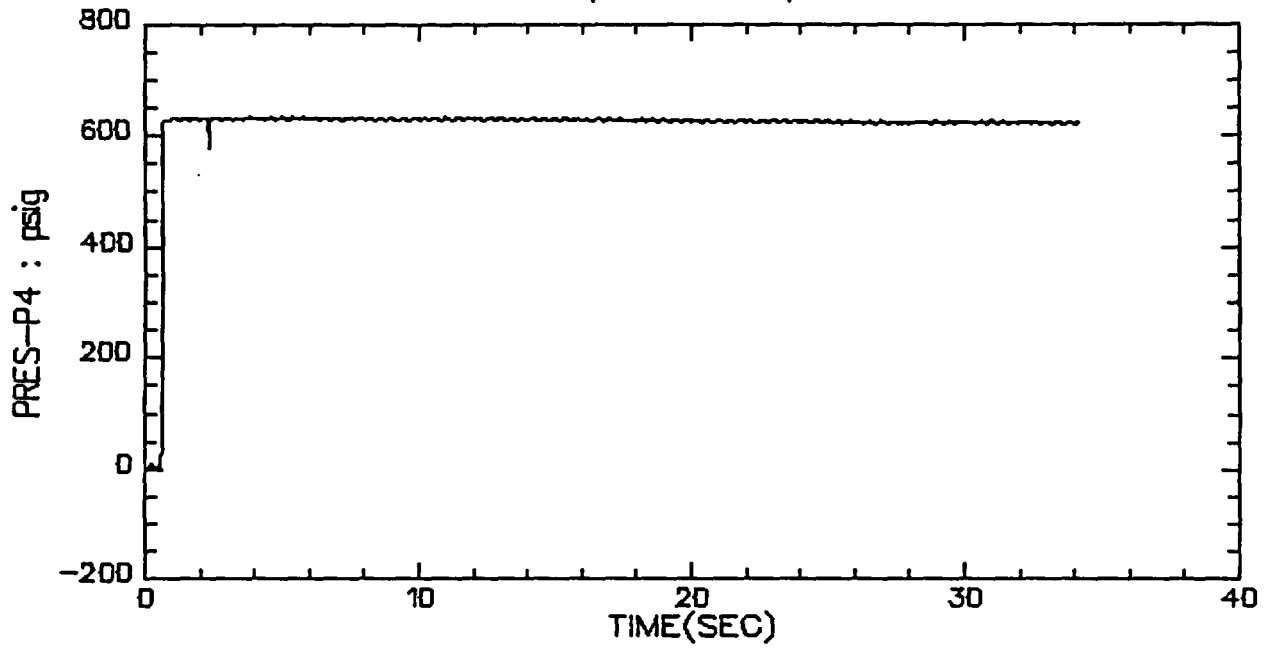

VALVE A, TEST 10, STEP 1

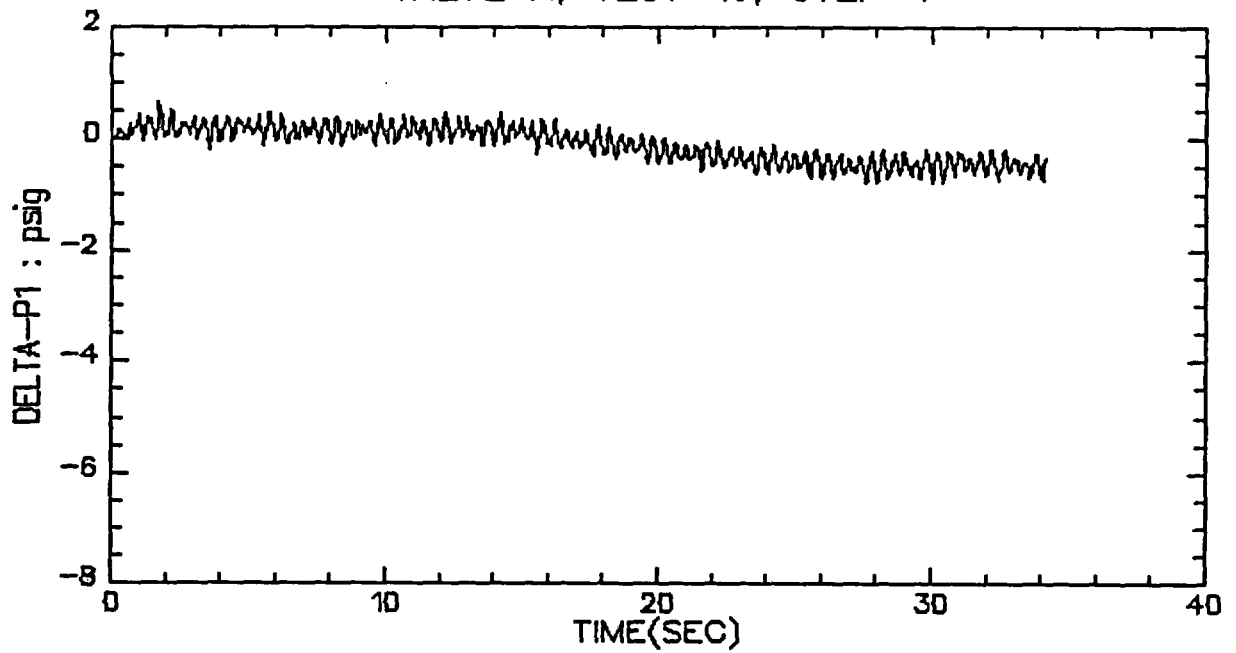

VALVE A, TEST 10, STEP 1

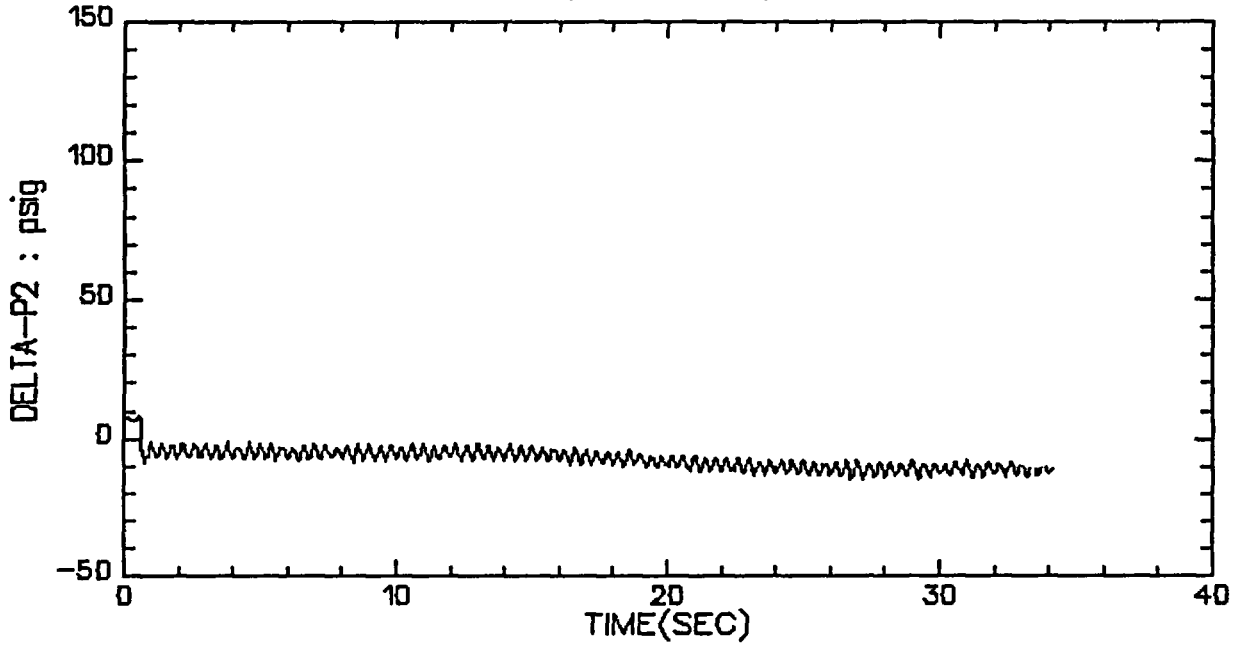

VALVE A, TEST 10, STEP 1

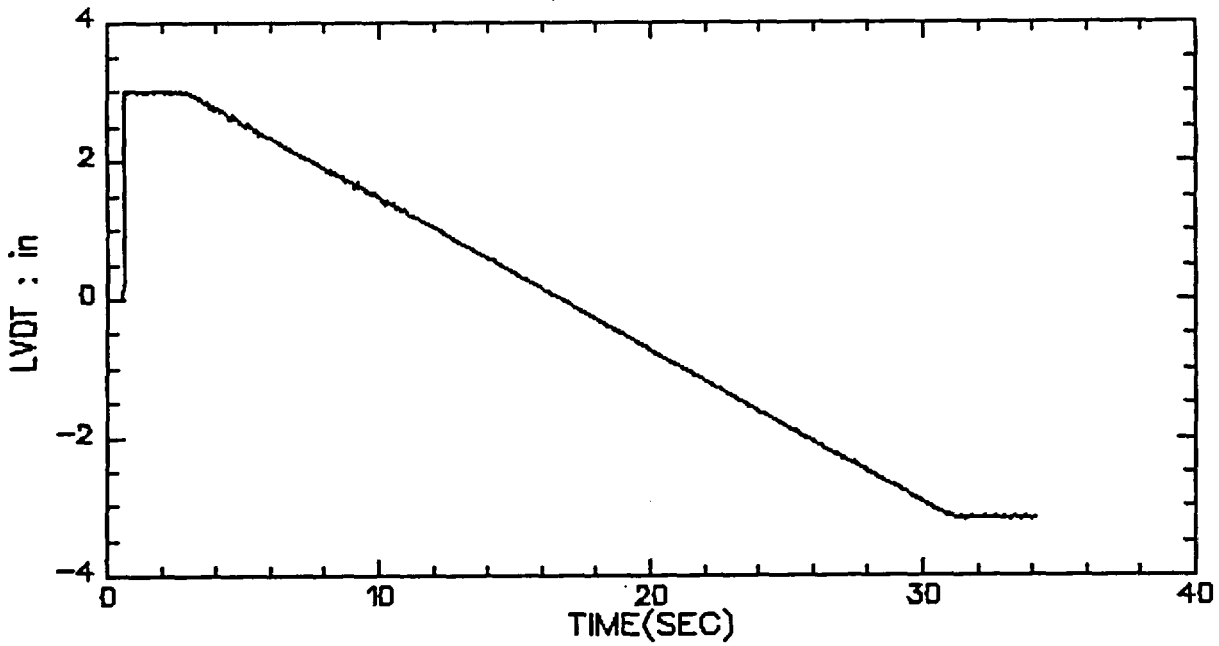

VALVE A, TEST 10, STEP 1

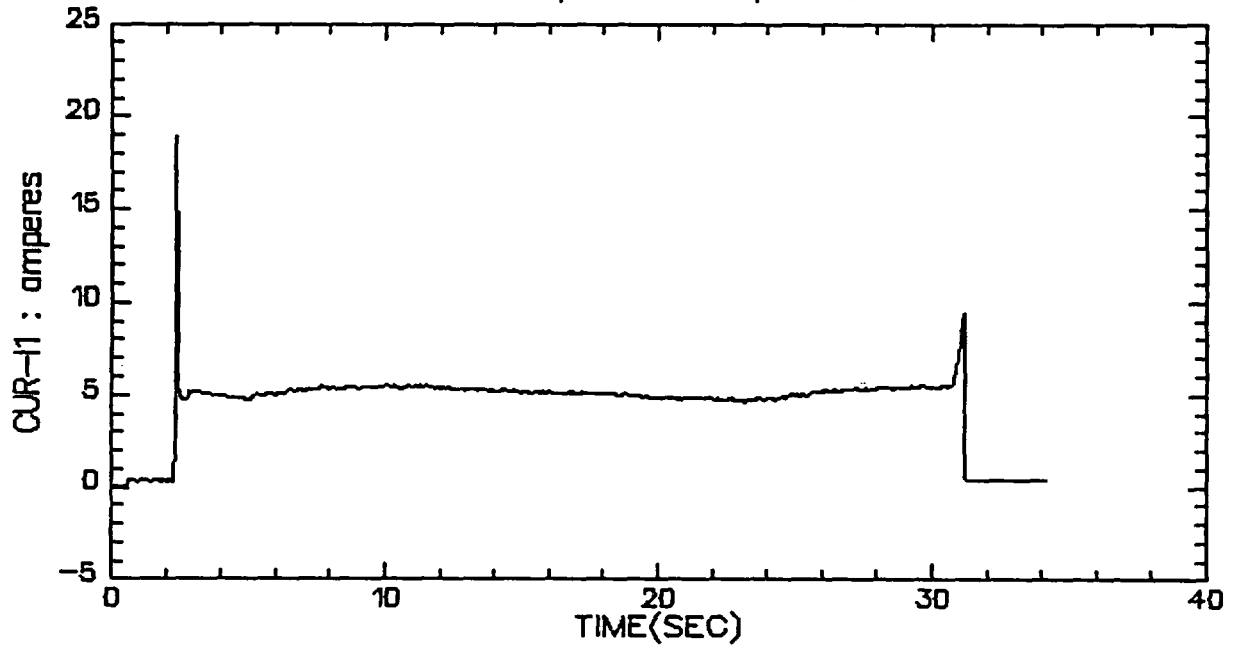

VALVE A, TEST 10, STEP 1

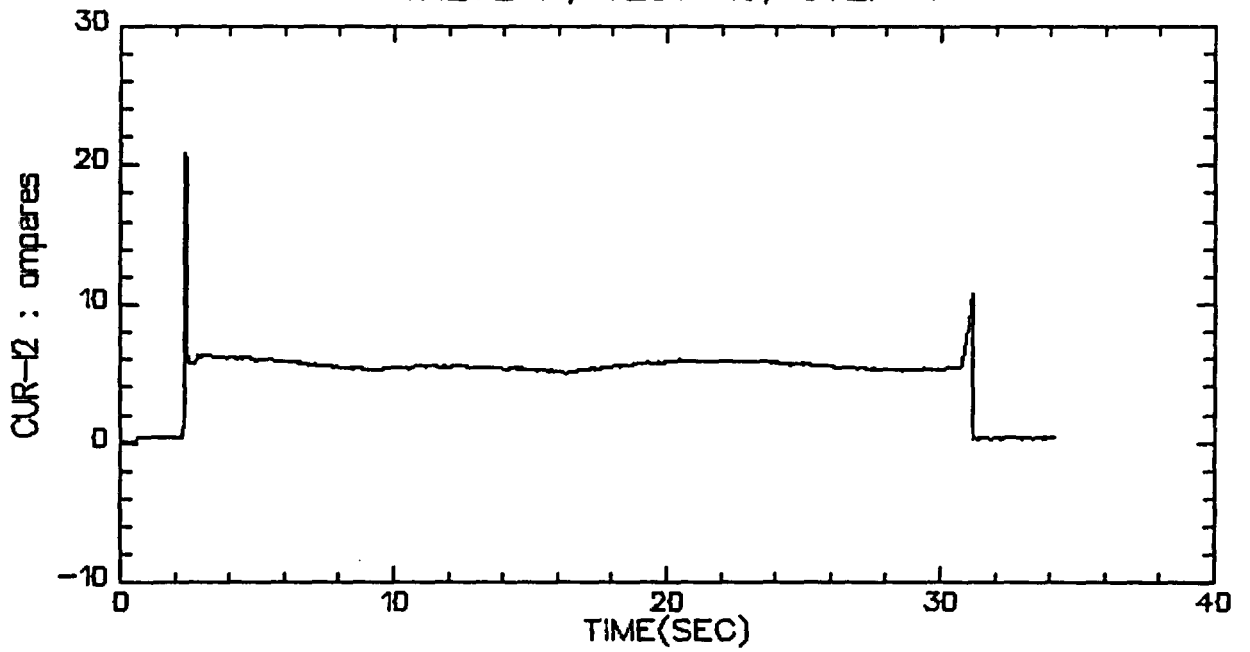

VALVE A, TEST 10, STEP 1

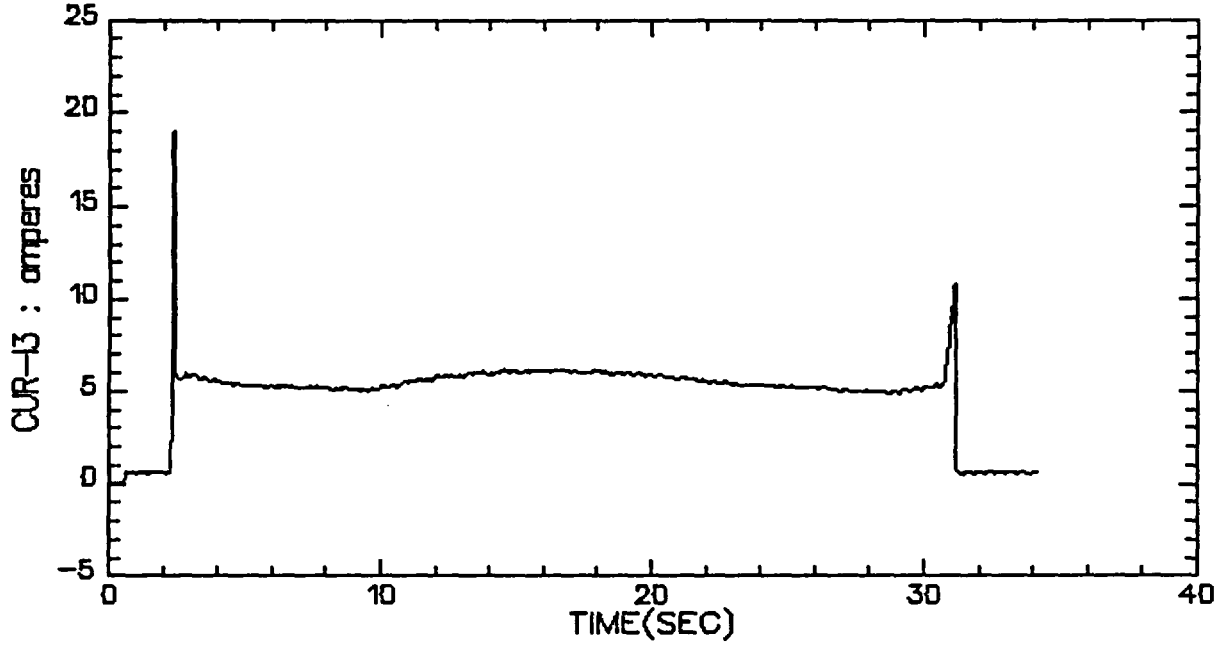

VALVE A, TEST 10, STEP 1

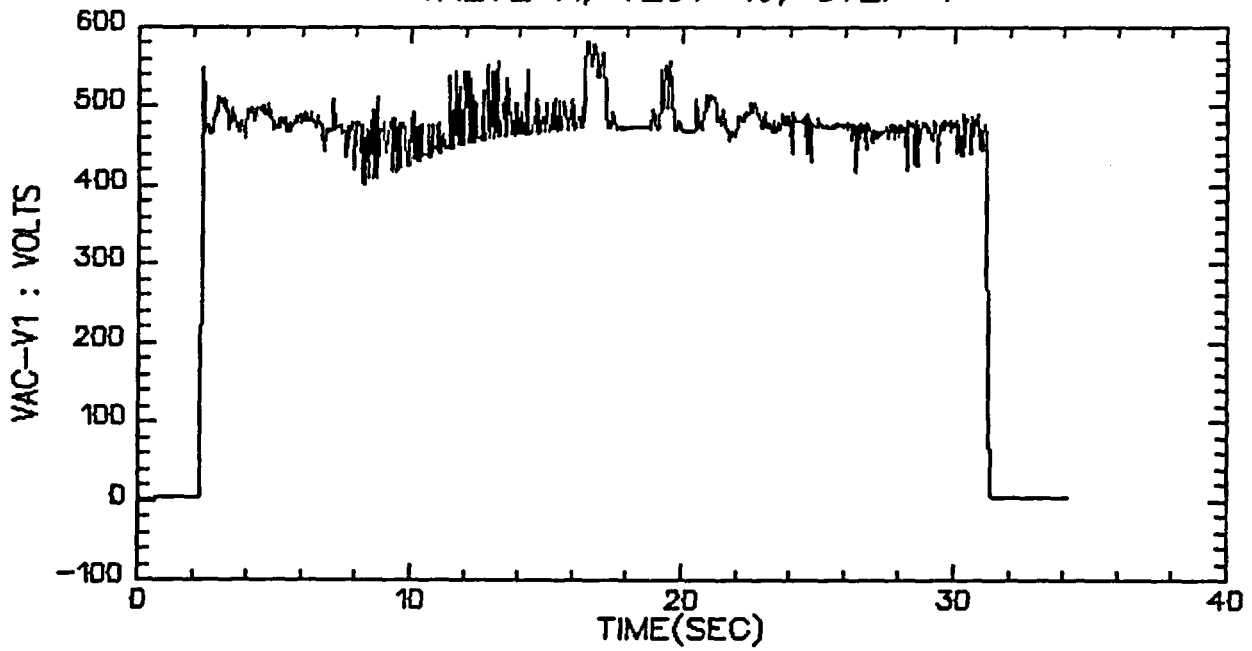

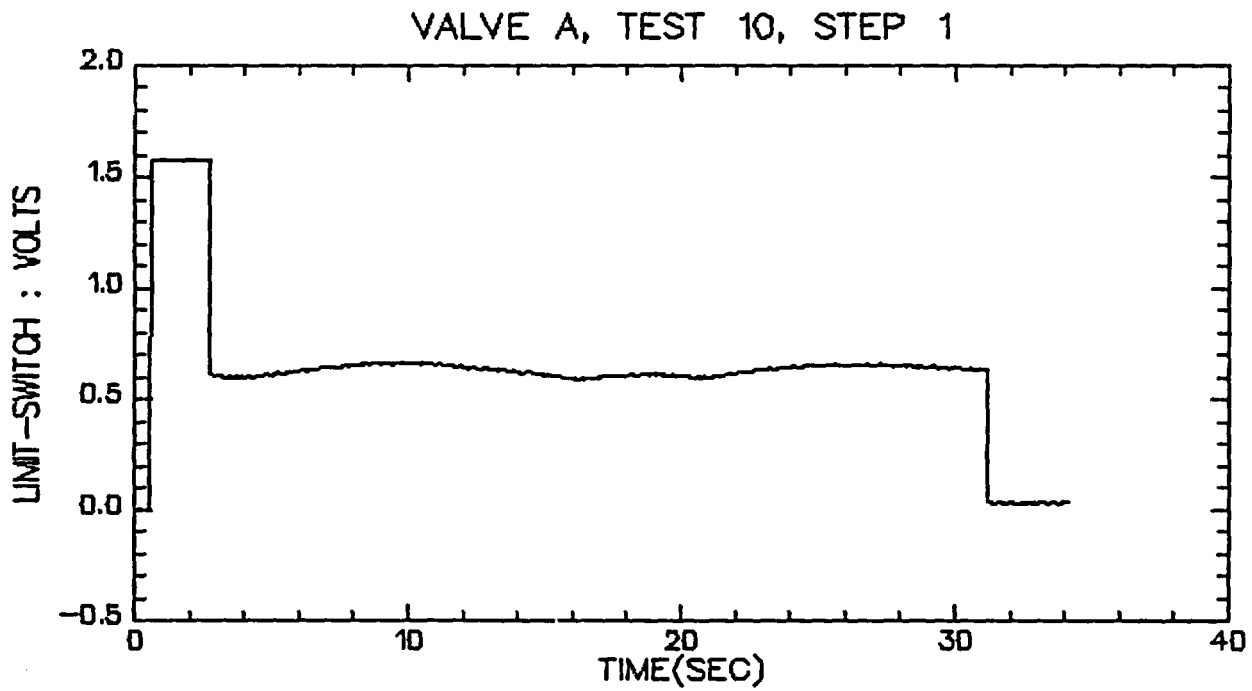
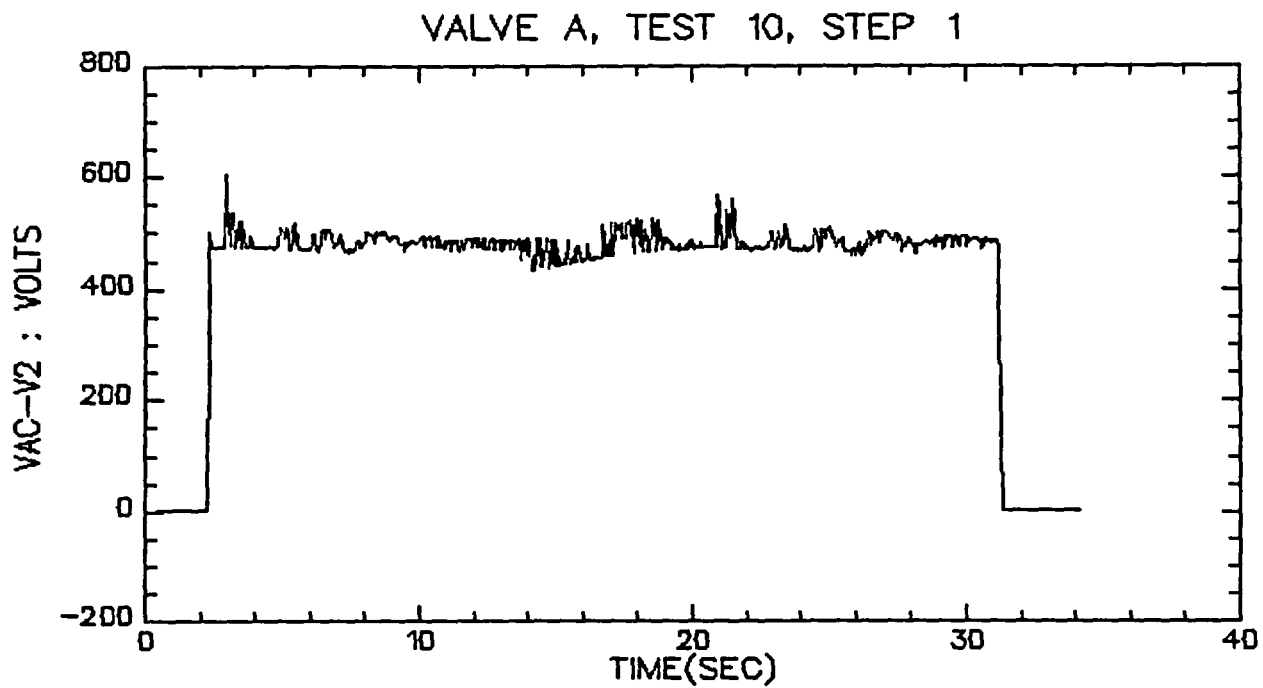

VALVE A, TEST 10, STEP 1

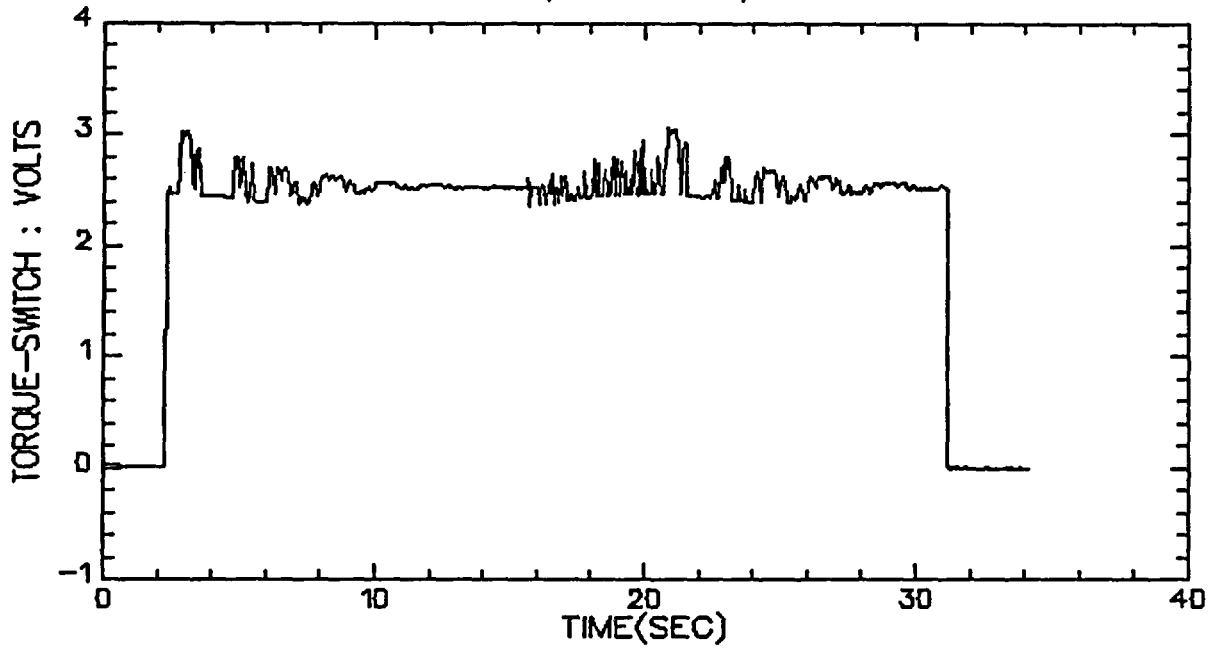

VALVE A, TEST 10, STEP 1

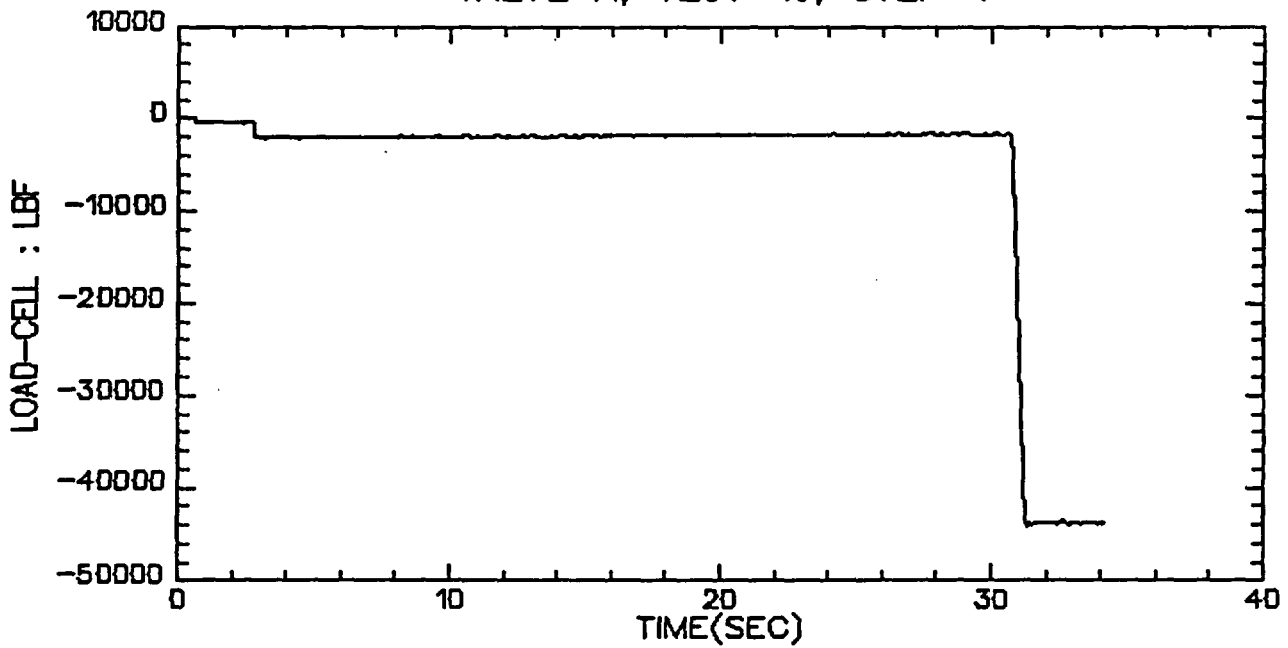

VALVE A, TEST 10, STEP 2

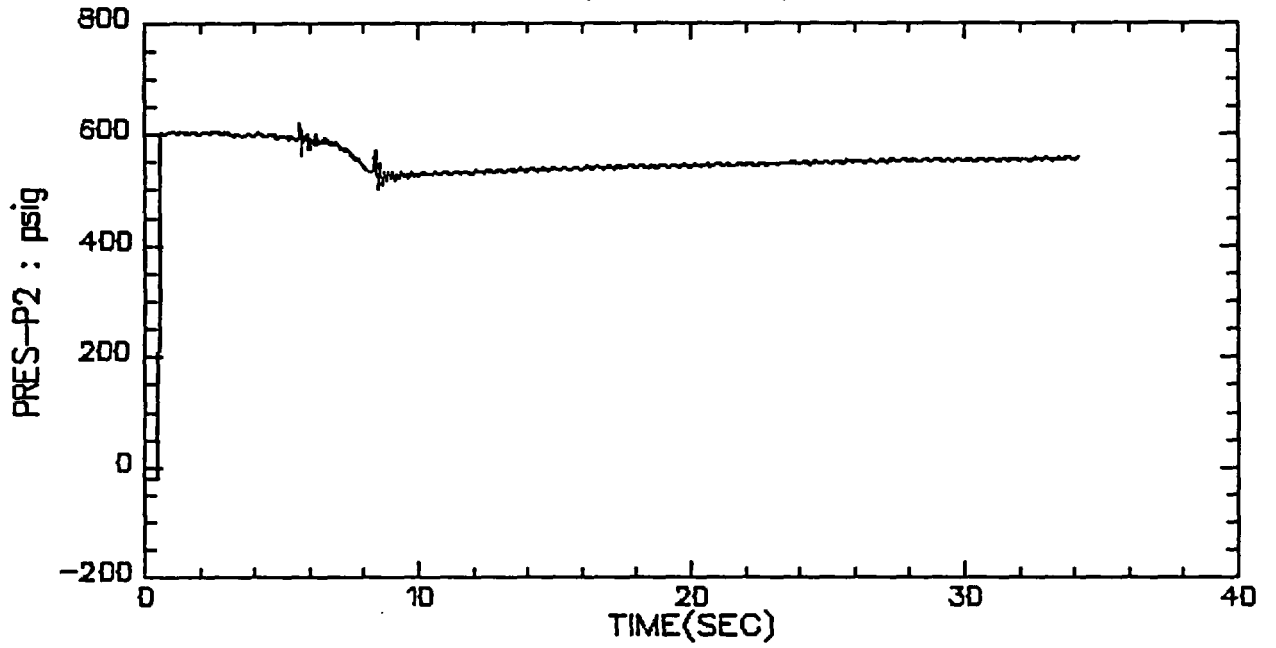

VALVE A, TEST 10, STEP 2

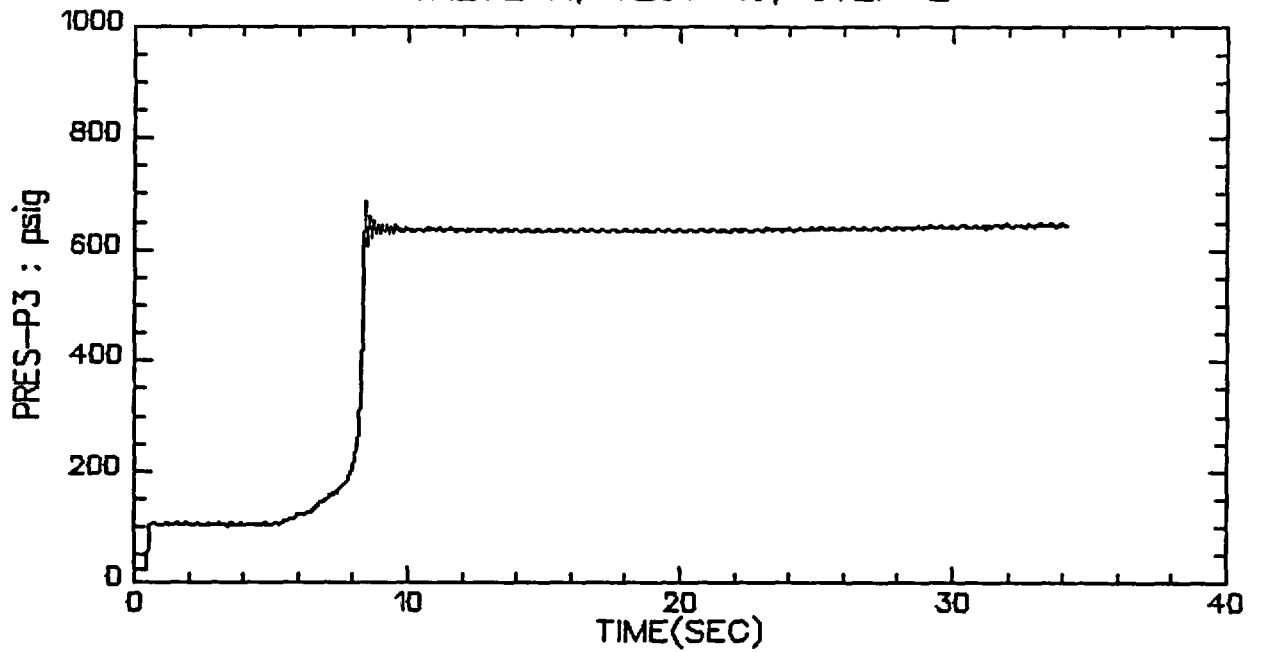

VALVE A, TEST 10, STEP 2

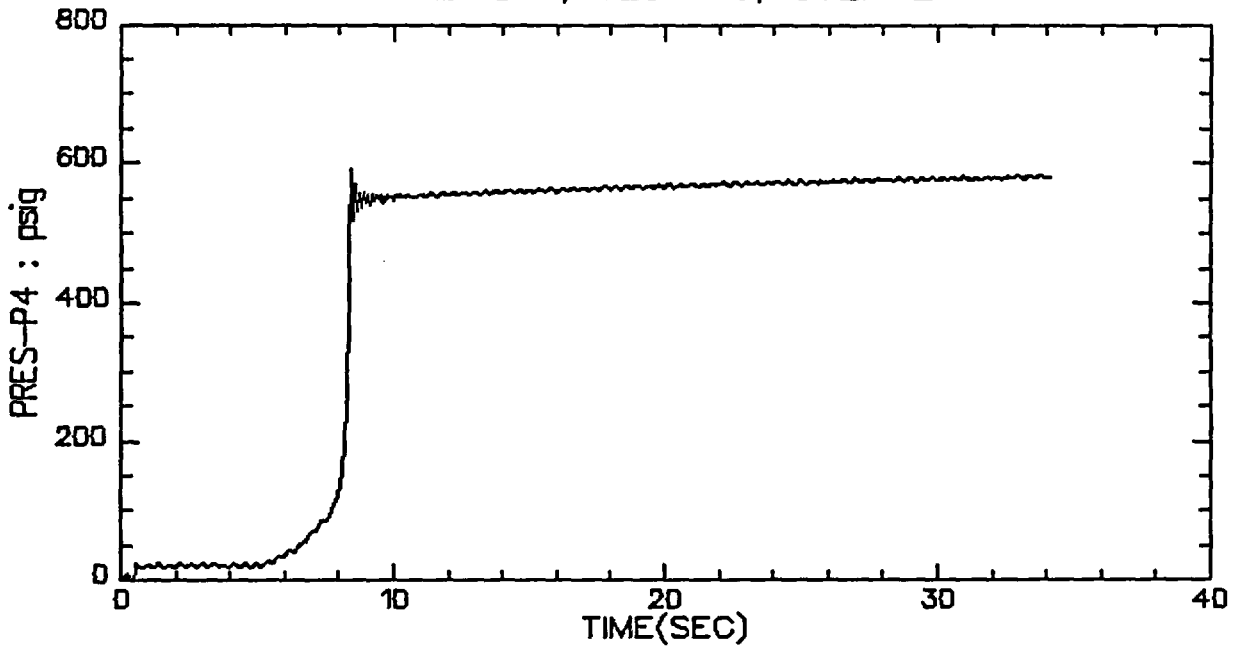

VALVE A, TEST 10, STEP 2

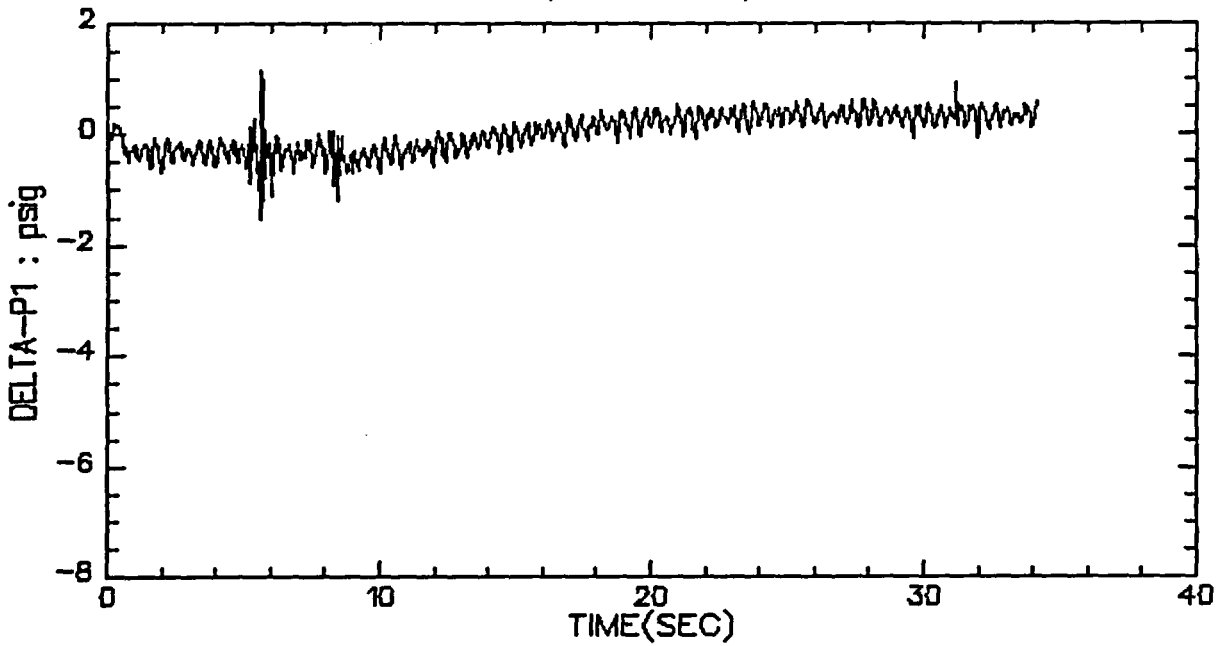

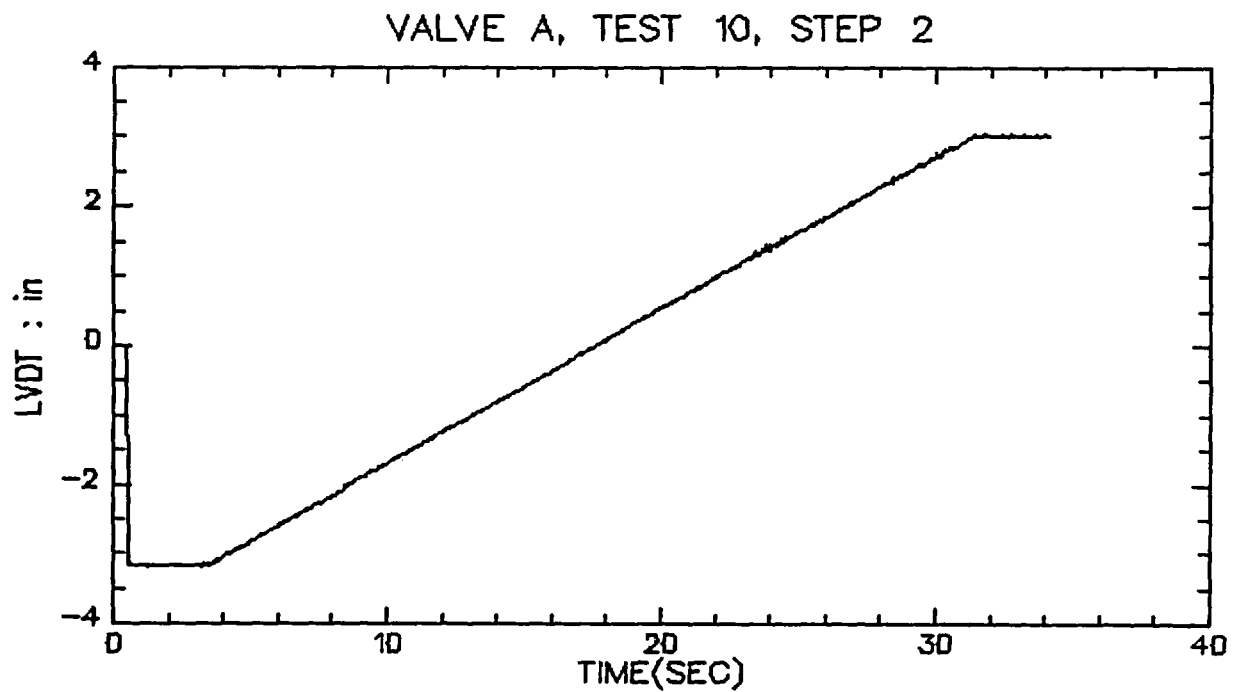
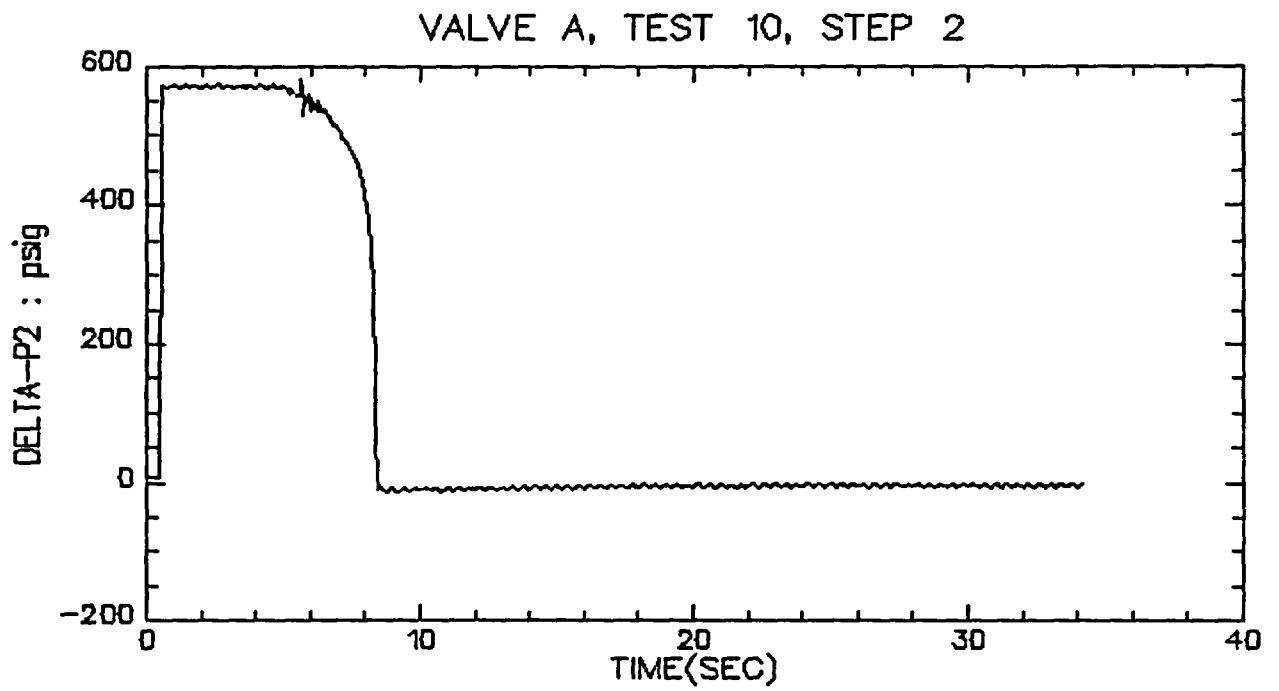

VALVE A, TEST 10, STEP 2

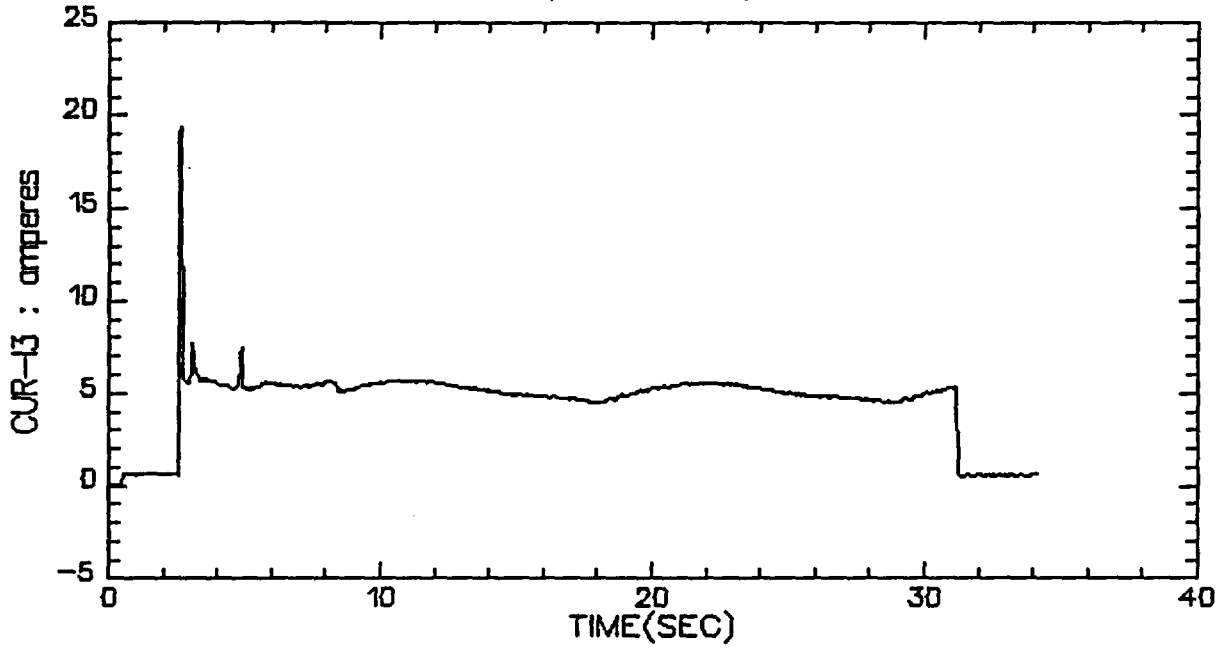

VALVE A, TEST 10, STEP 2

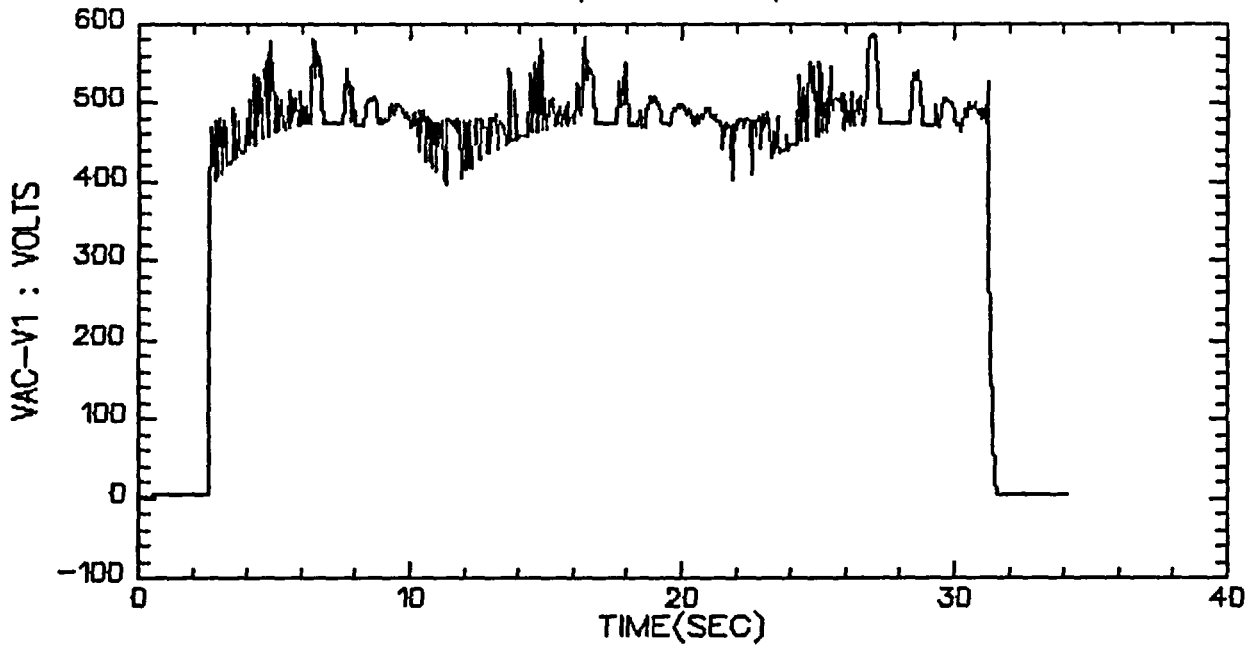

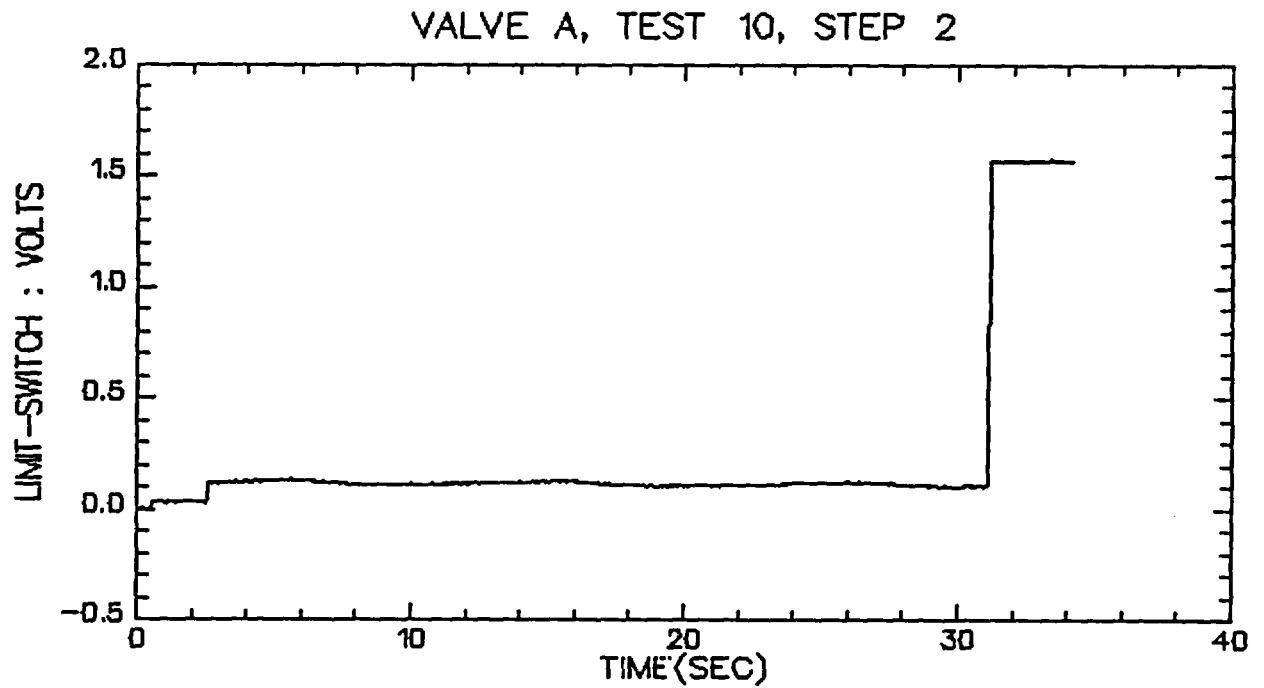
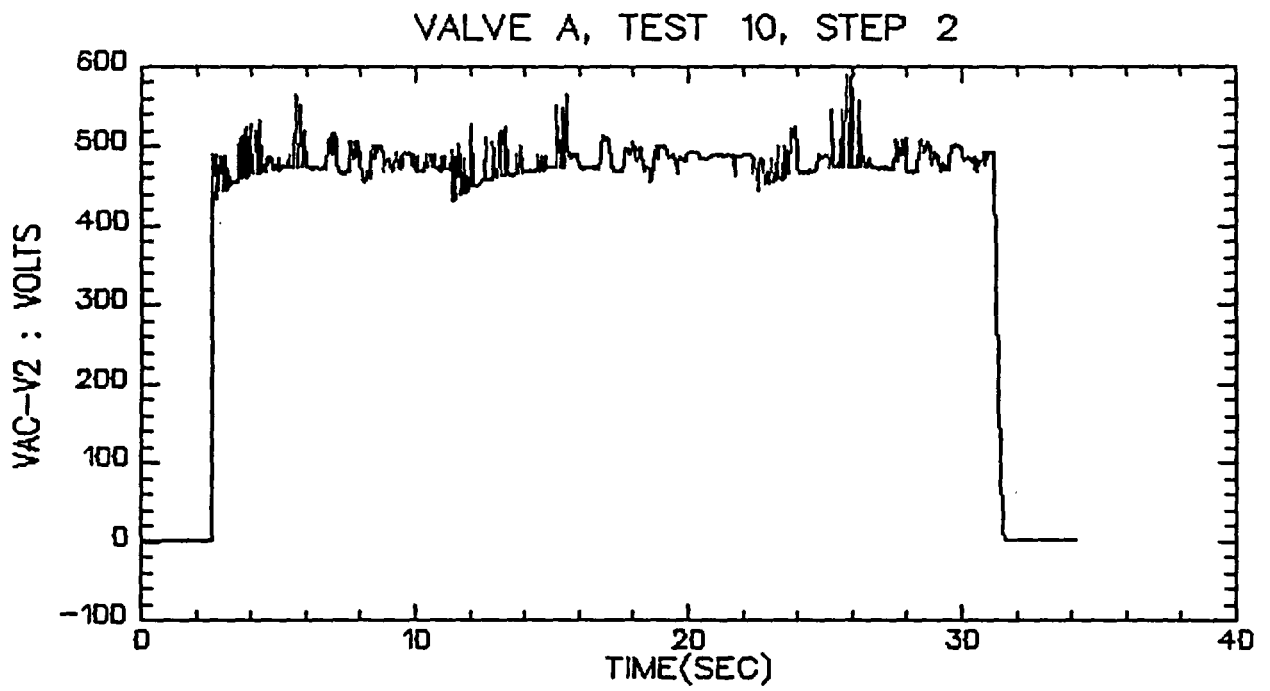

VALVE A, TEST 10, STEP 2

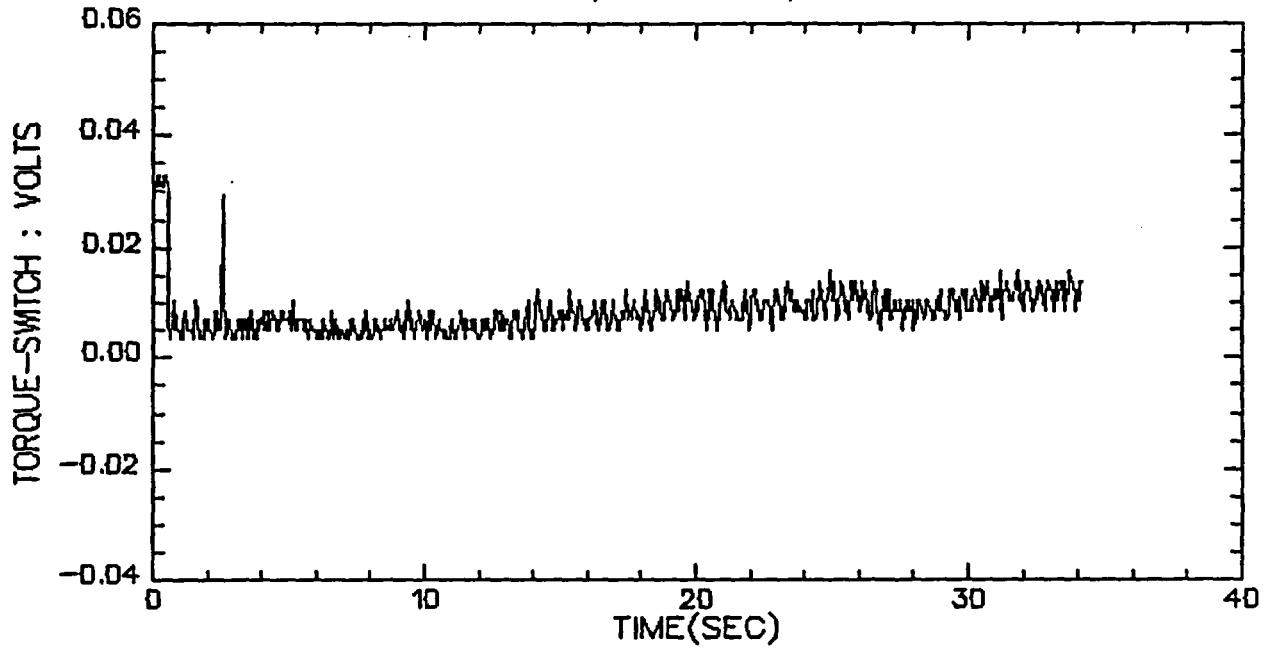

VALVE A, TEST 10, STEP 2

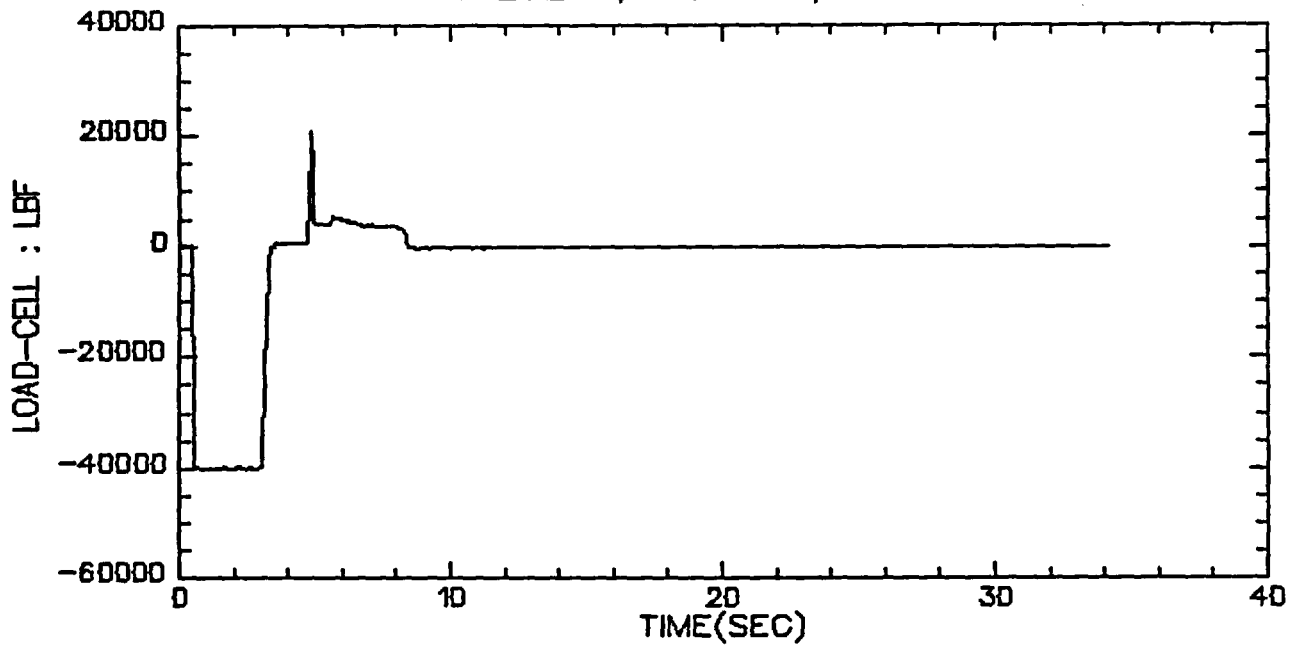

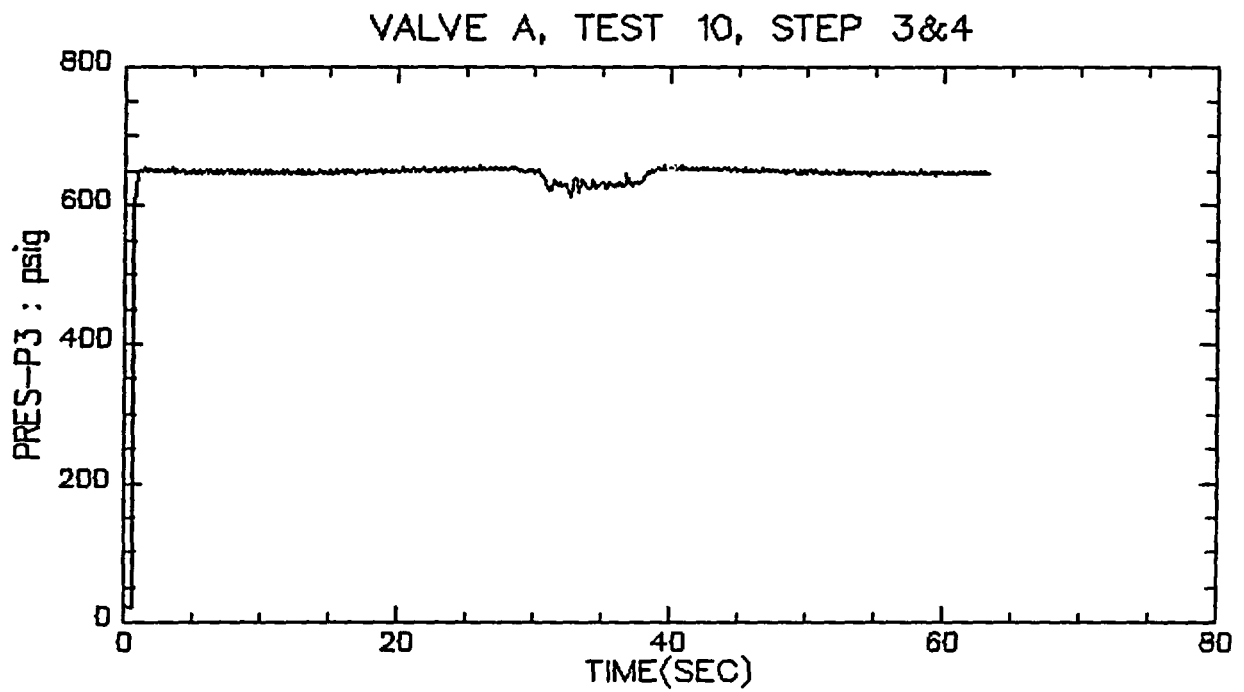
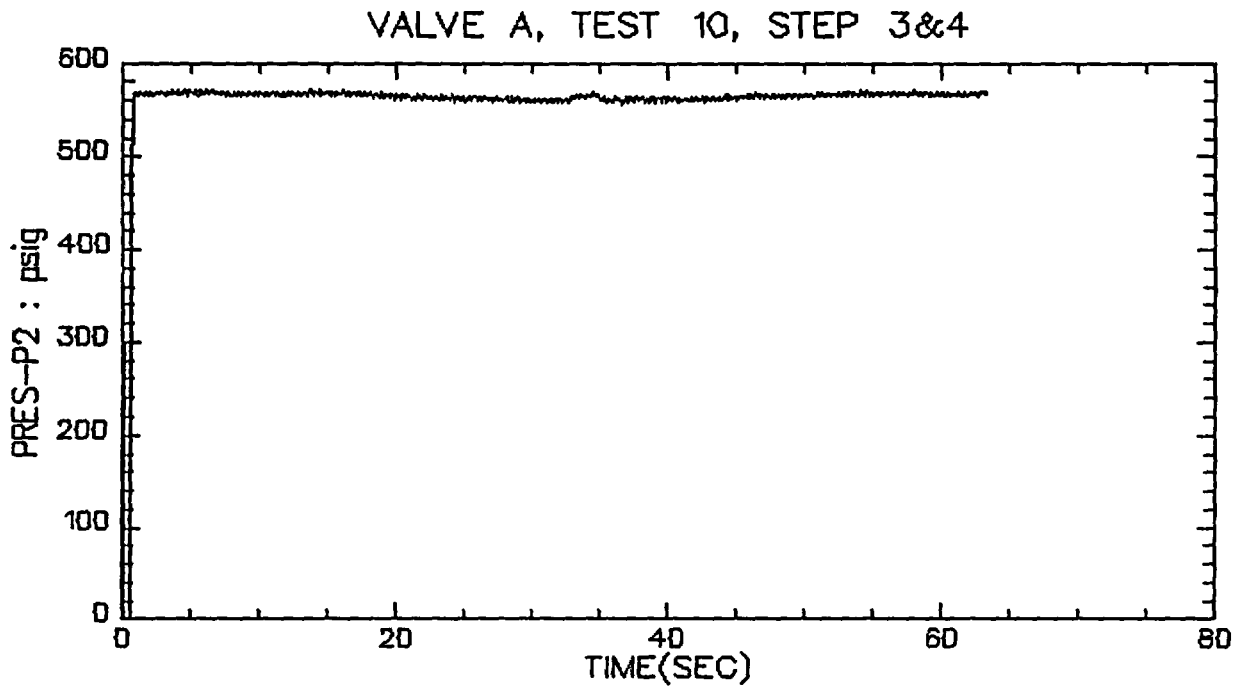

VALVE A, TEST 10, STEP 3&4

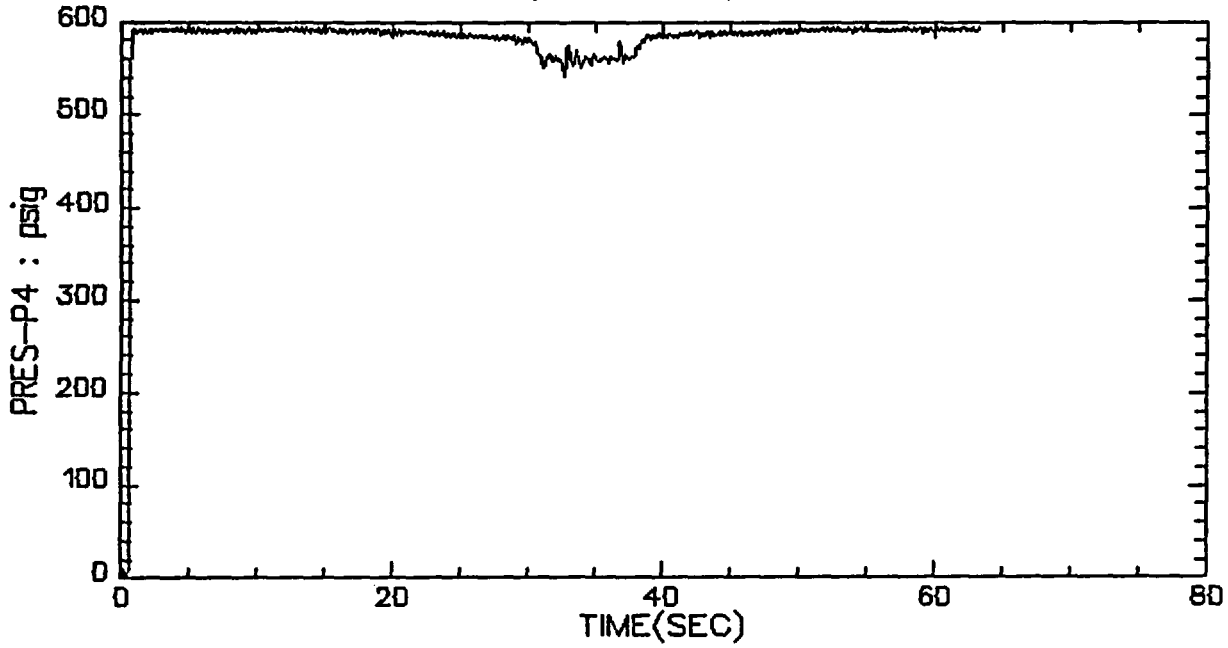

VALVE A, TEST 10, STEP 3&4

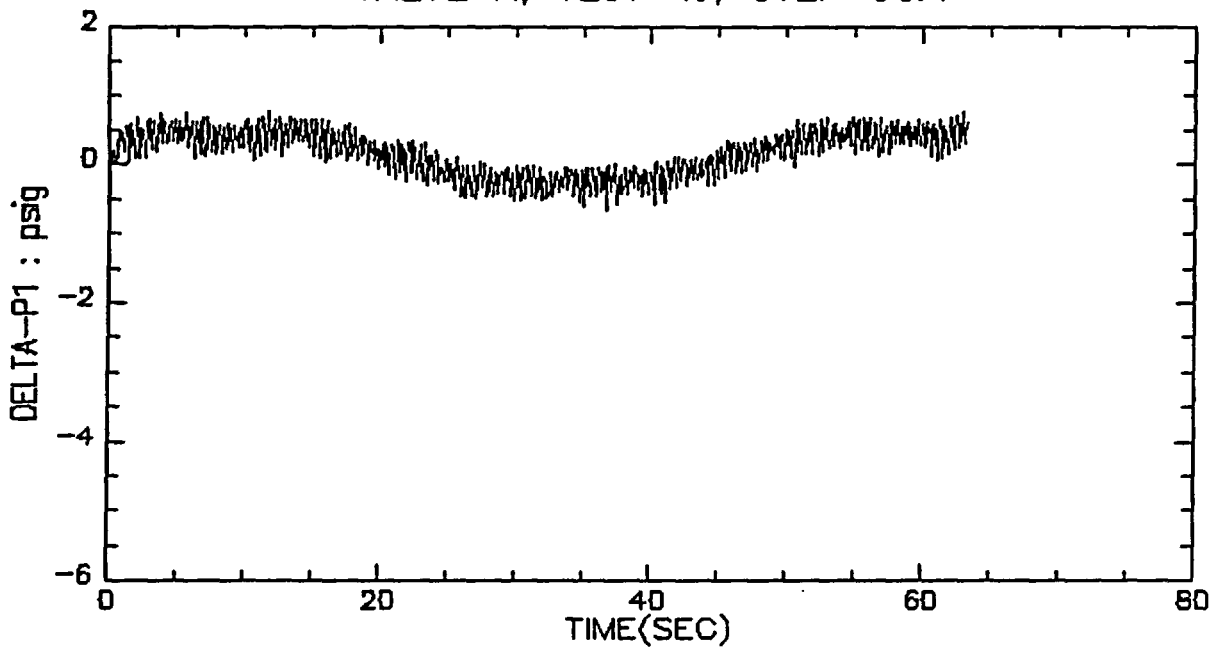

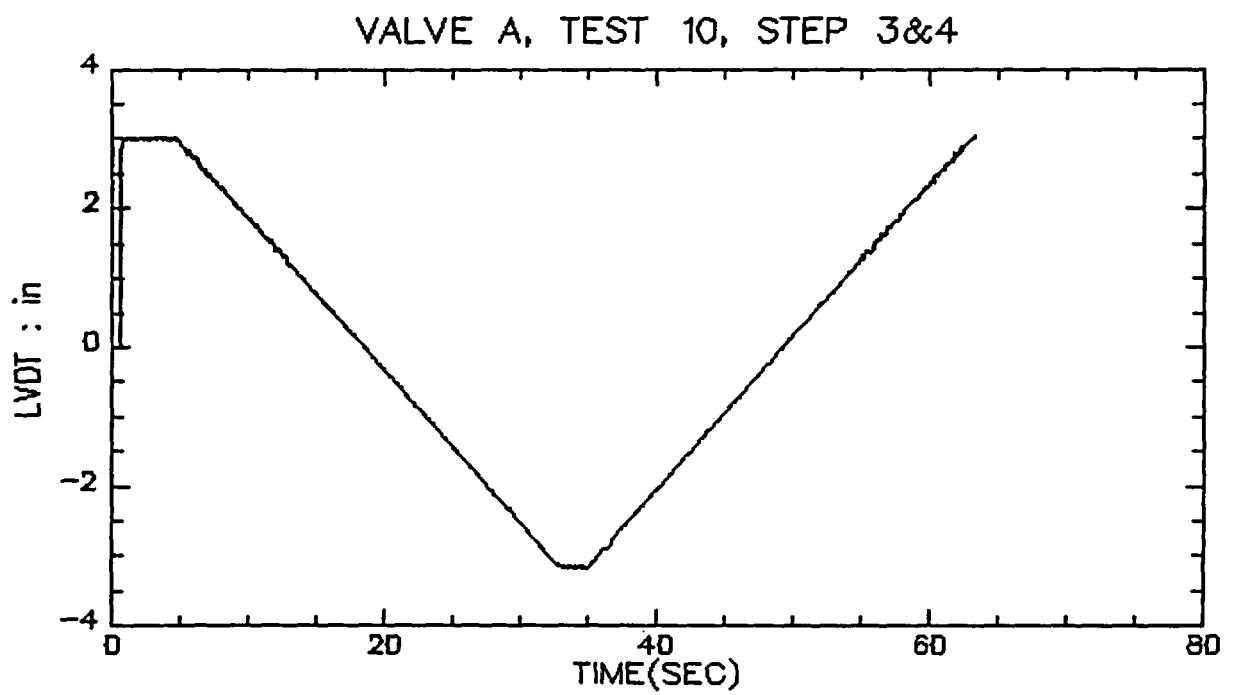
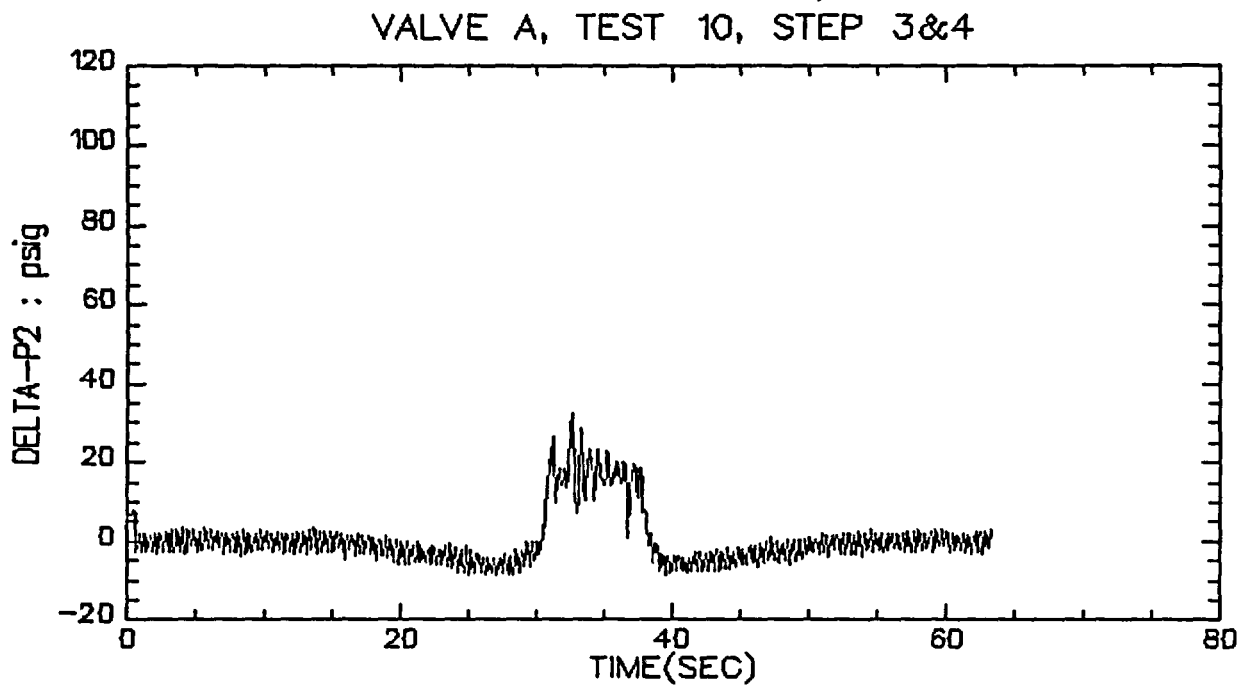

VALVE A, TEST 10, STEP 3&4

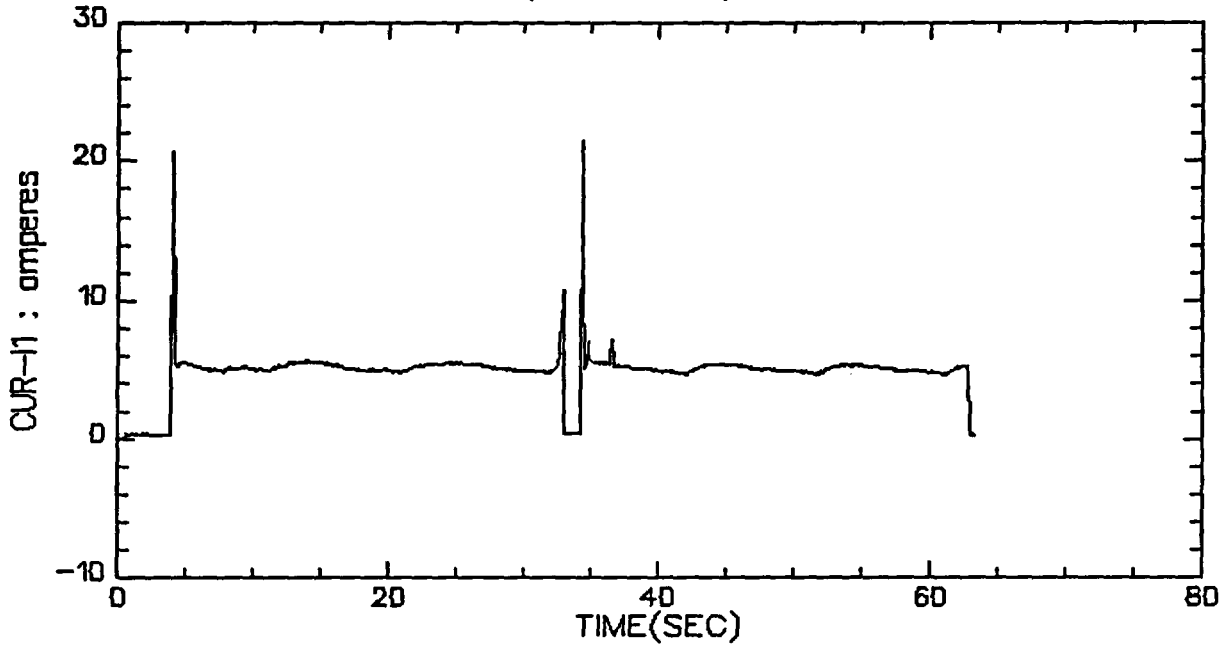

VALVE A, TEST 10, STEP 3&4

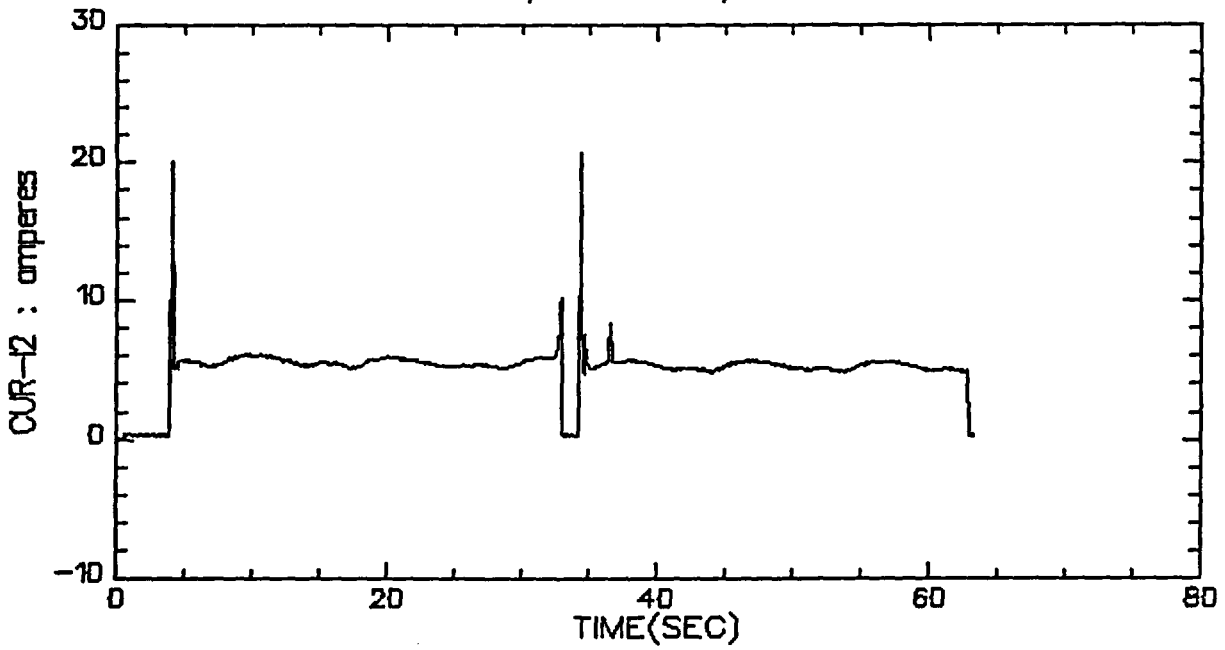

VALVE A, TEST 10, STEP 3&4

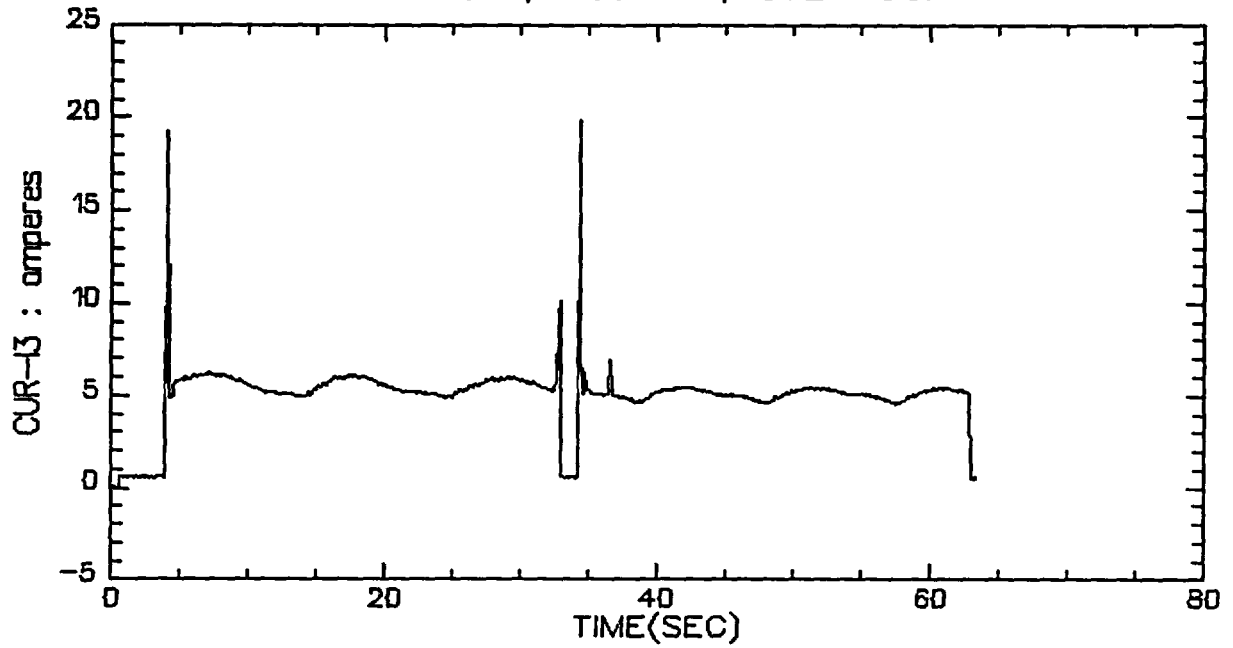

VALVE A, TEST 10, STEP 3&4

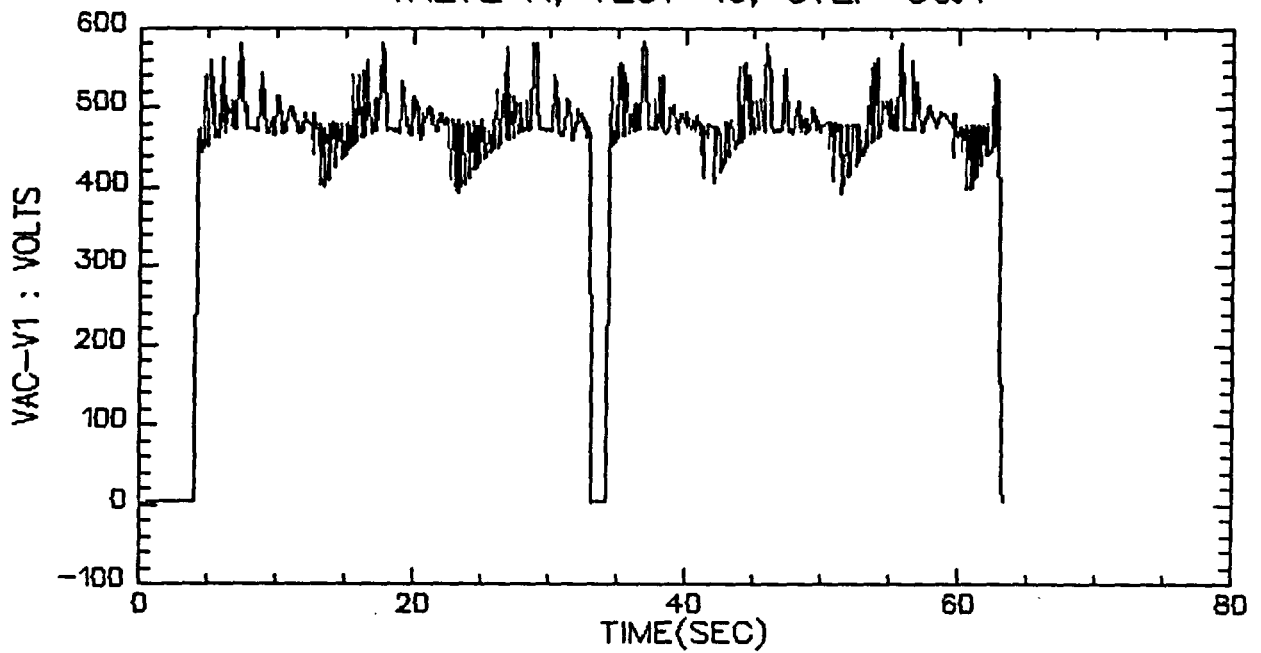

VALVE A, TEST 10, STEP 3&4

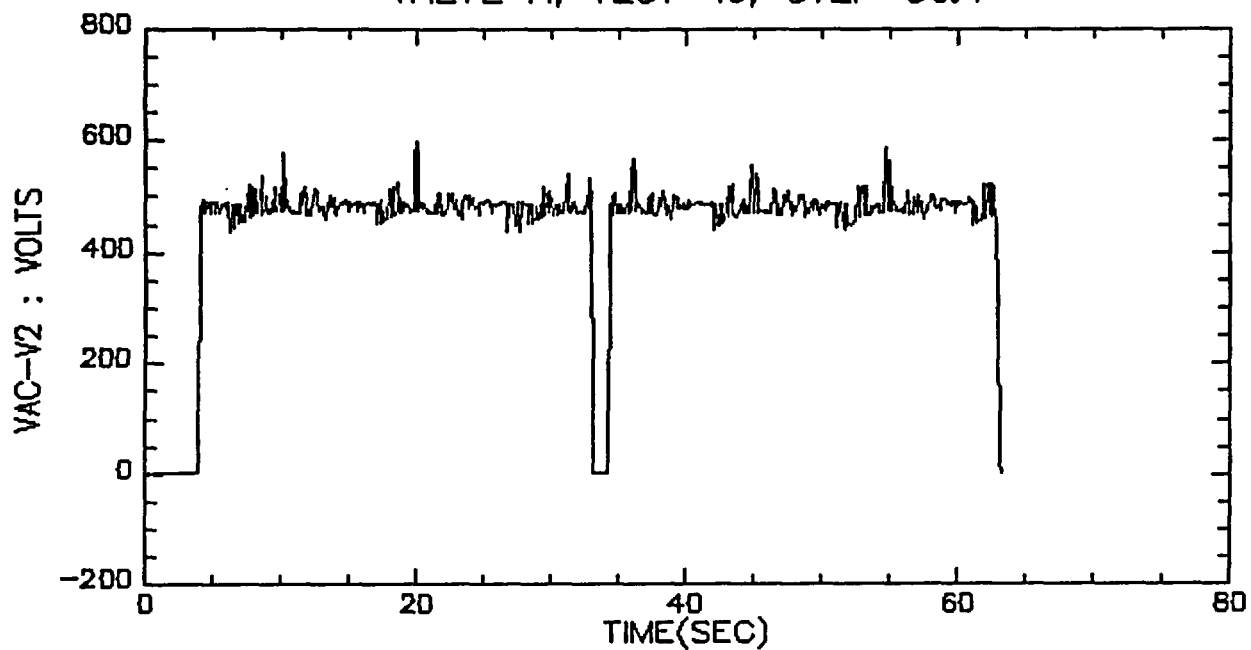

VALVE A, TEST 10, STEP 3&4

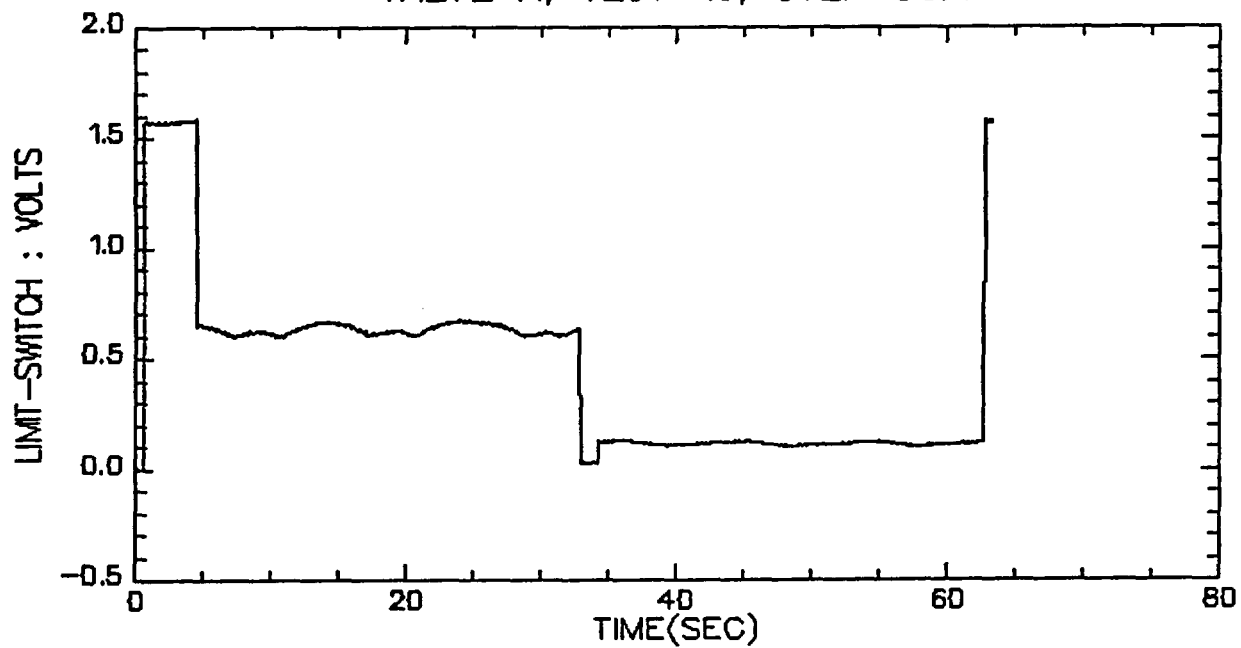

VALVE A, TEST 10, STEP 3&4

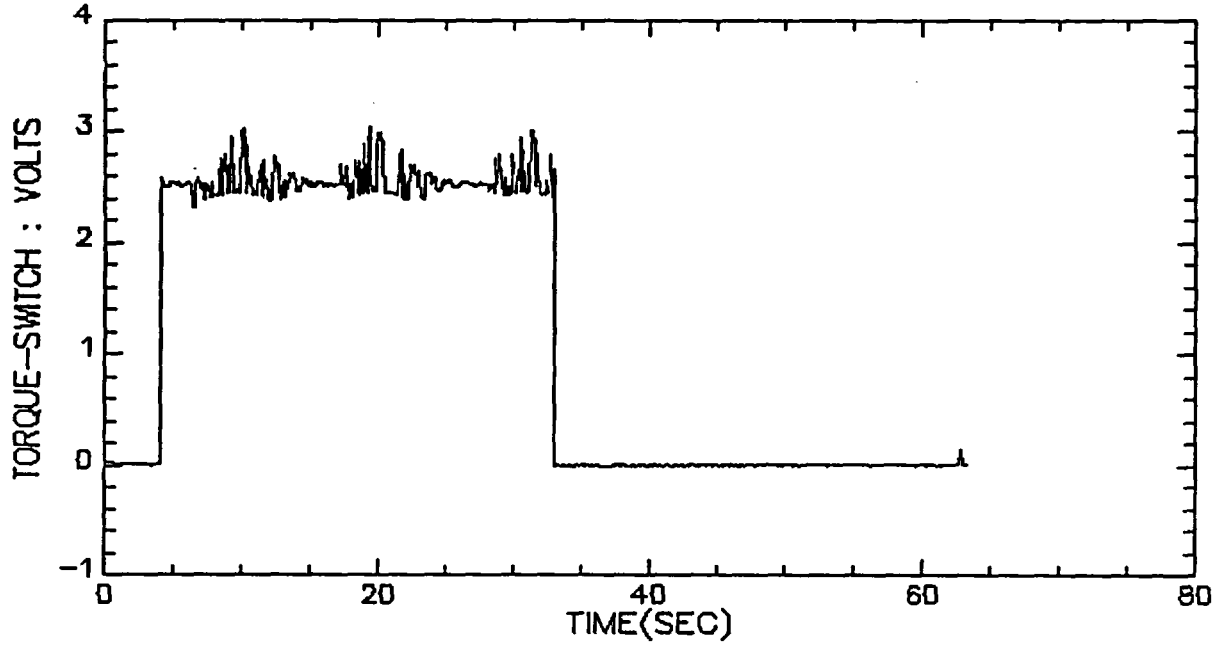

VALVE A, TEST 10, STEP 3&4

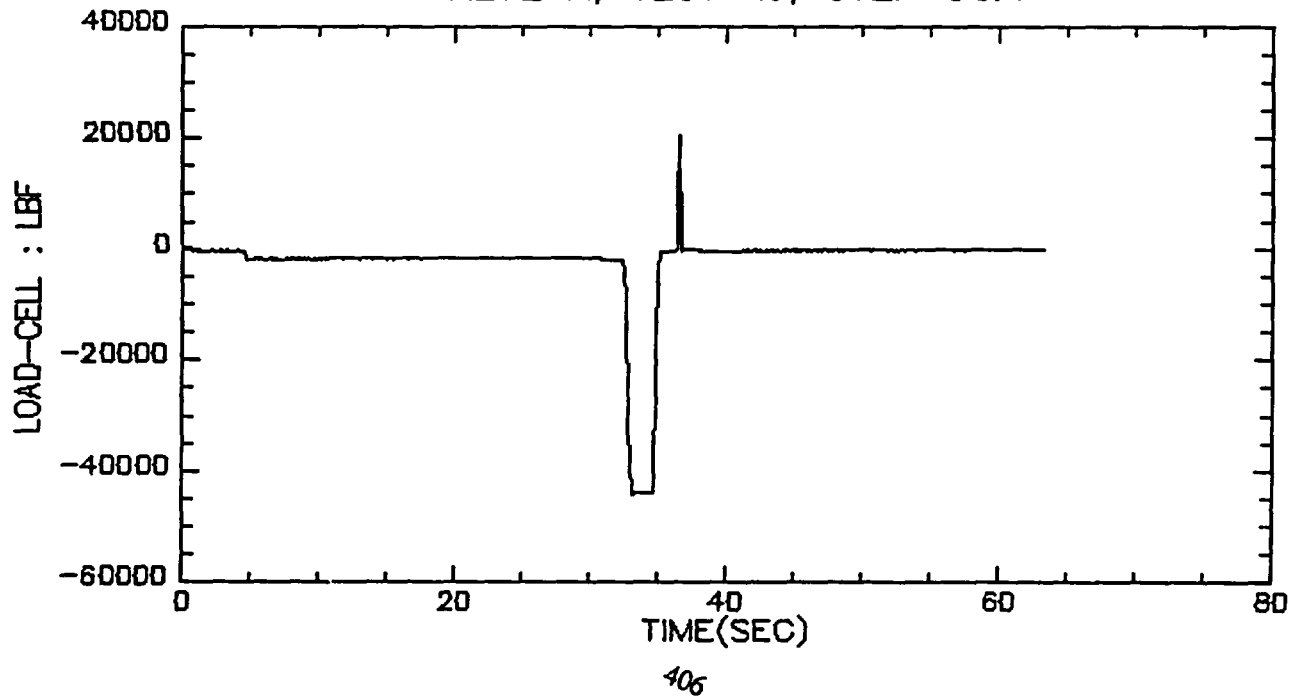

VALVE A, TEST 10, STEP 5

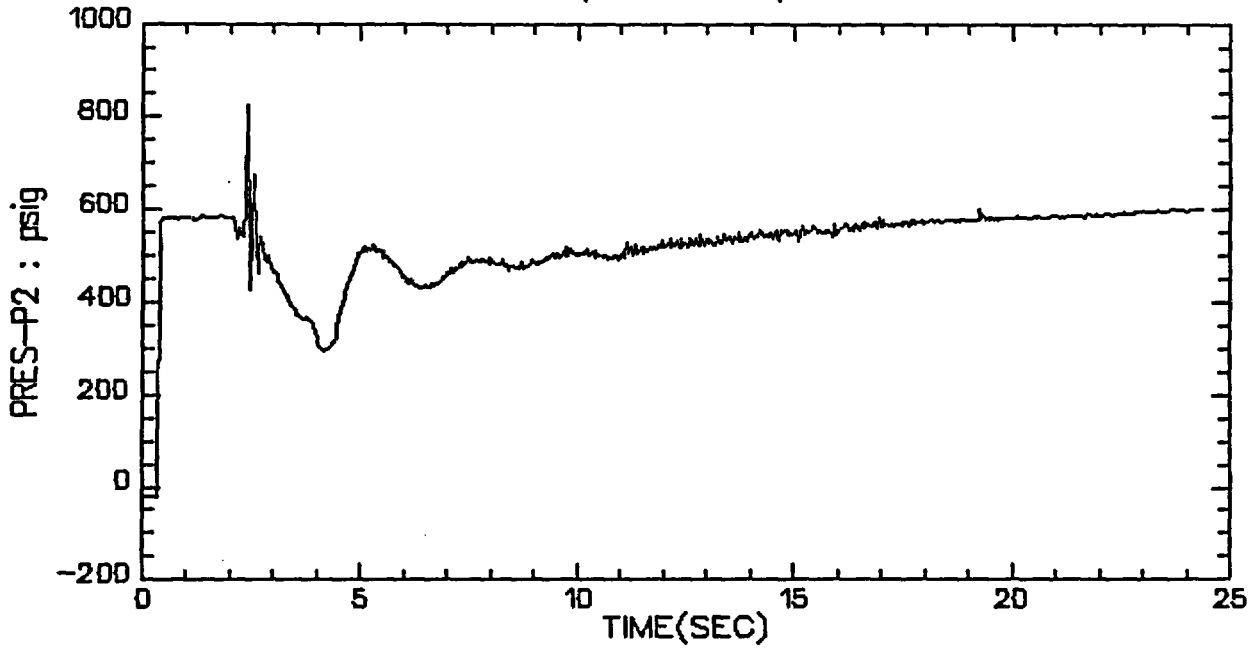

VALVE A, TEST 10, STEP 5

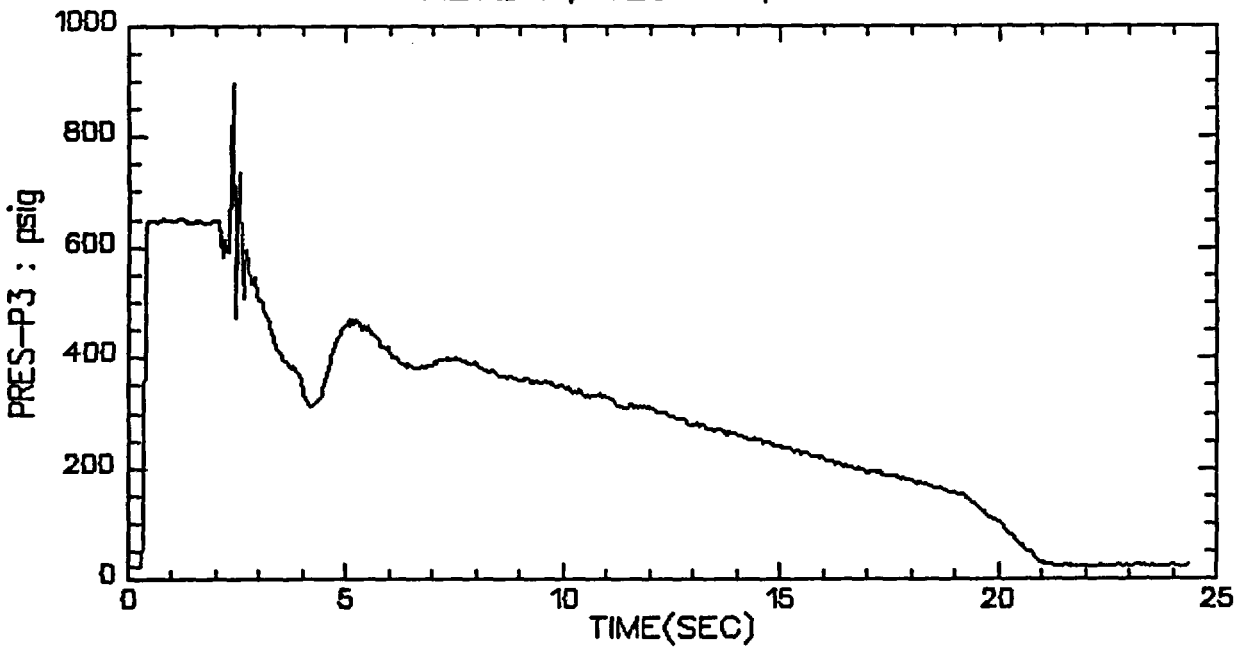

VALVE A, TEST 10, STEP 5

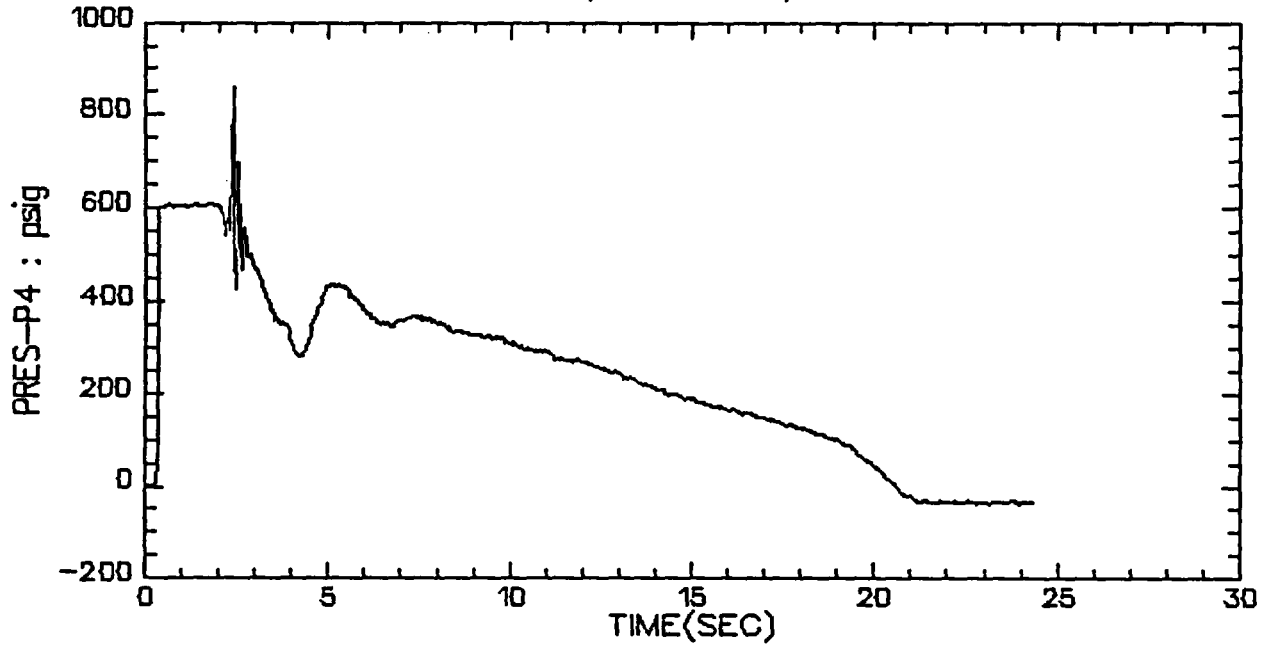

VALVE A, TEST 10, STEP 5

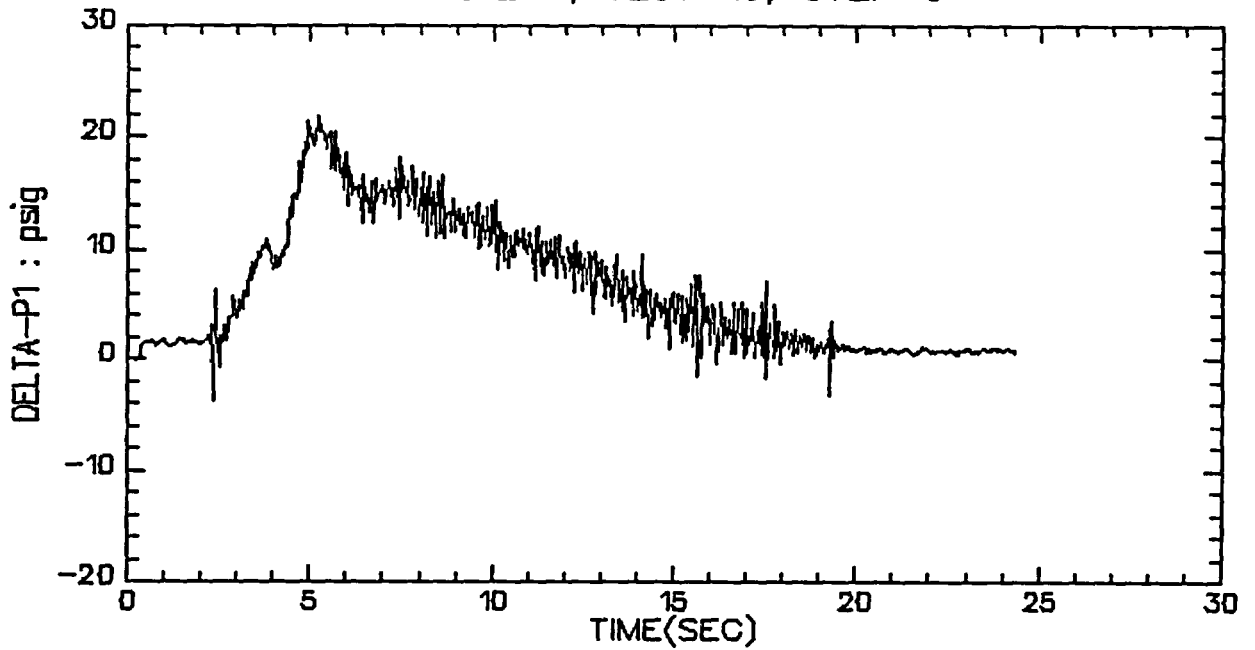

VALVE A, TEST 10, STEP 5

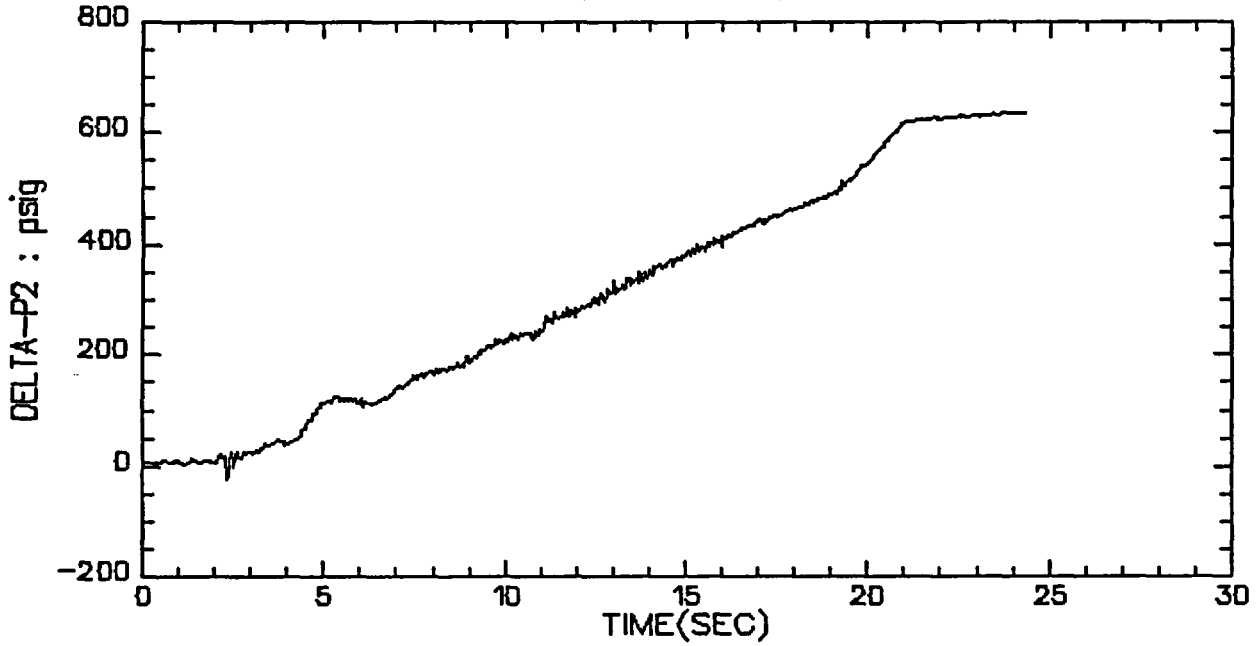

VALVE A, TEST 10, STEP 5

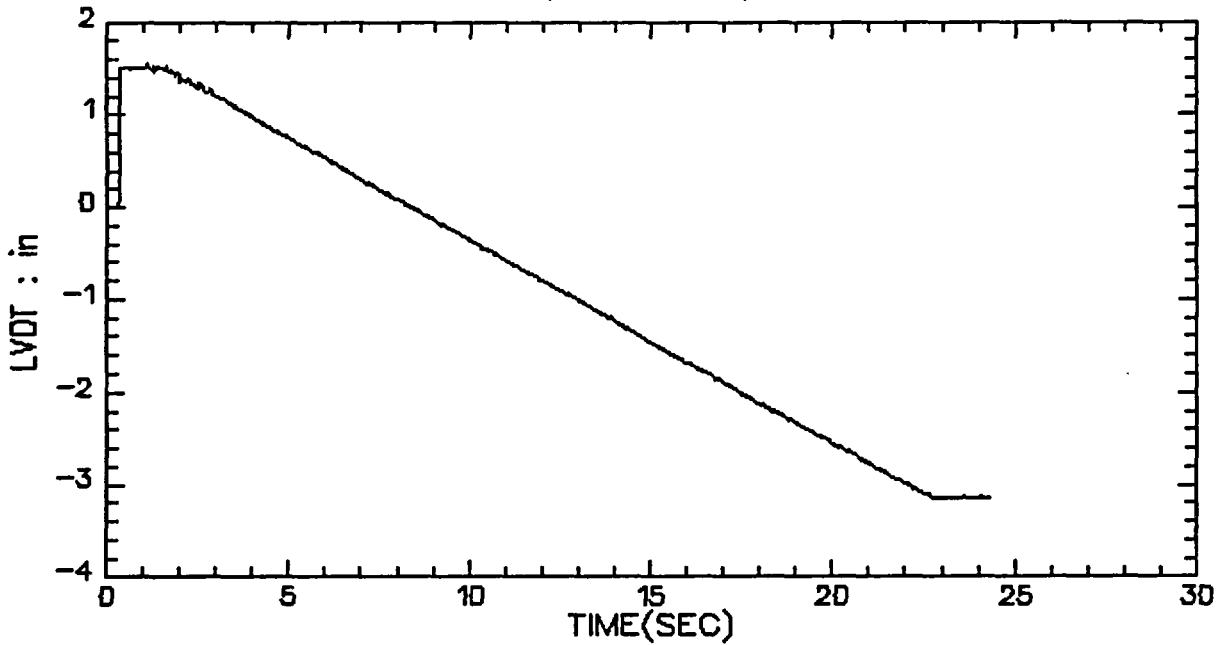

VALVE A, TEST 10, STEP 5

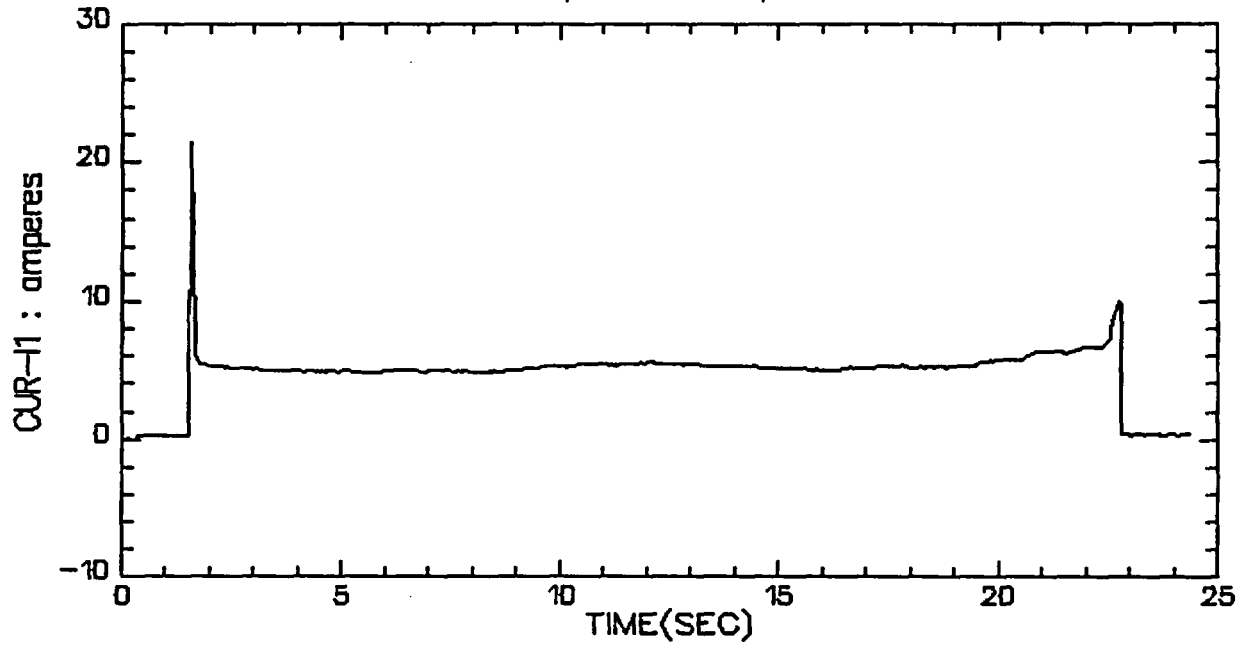

VALVE A, TEST 10, STEP 5

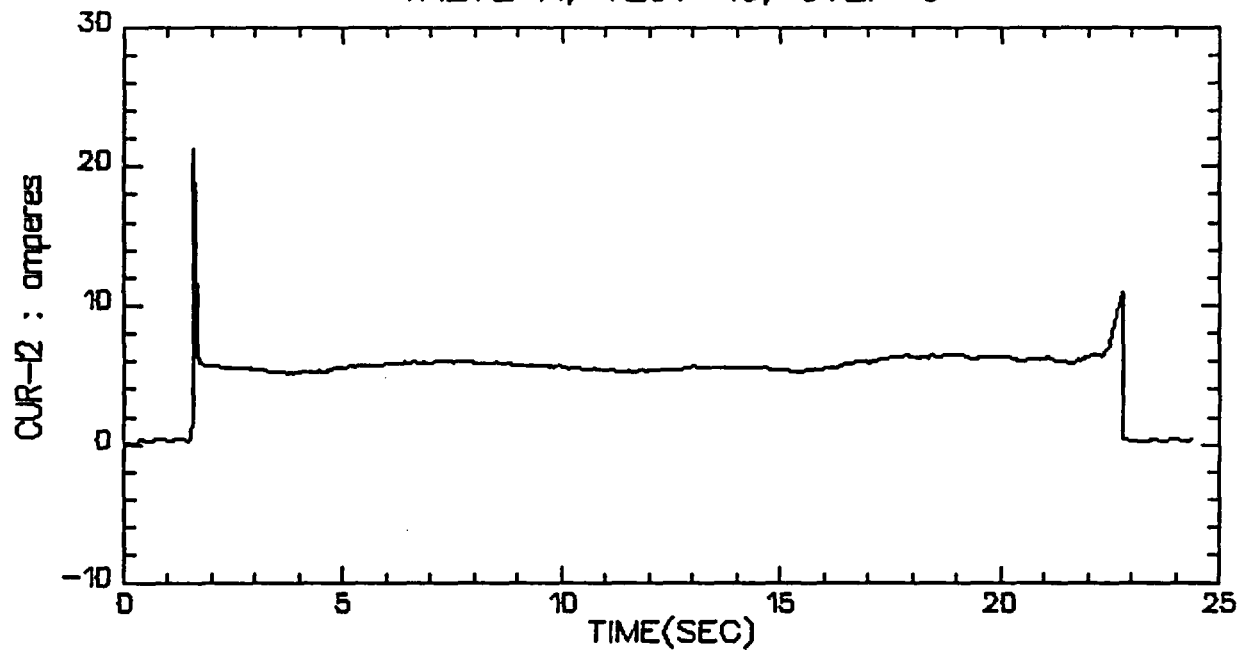

VALVE A, TEST 10, STEP 5

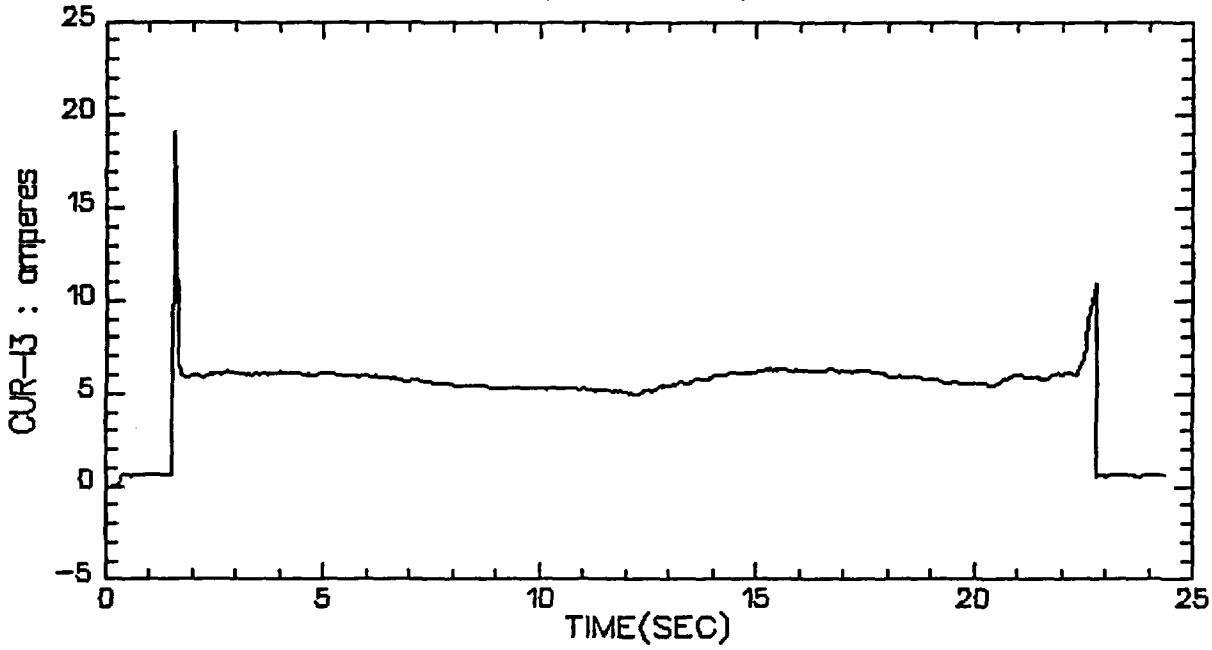

VALVE A, TEST 10, STEP 5

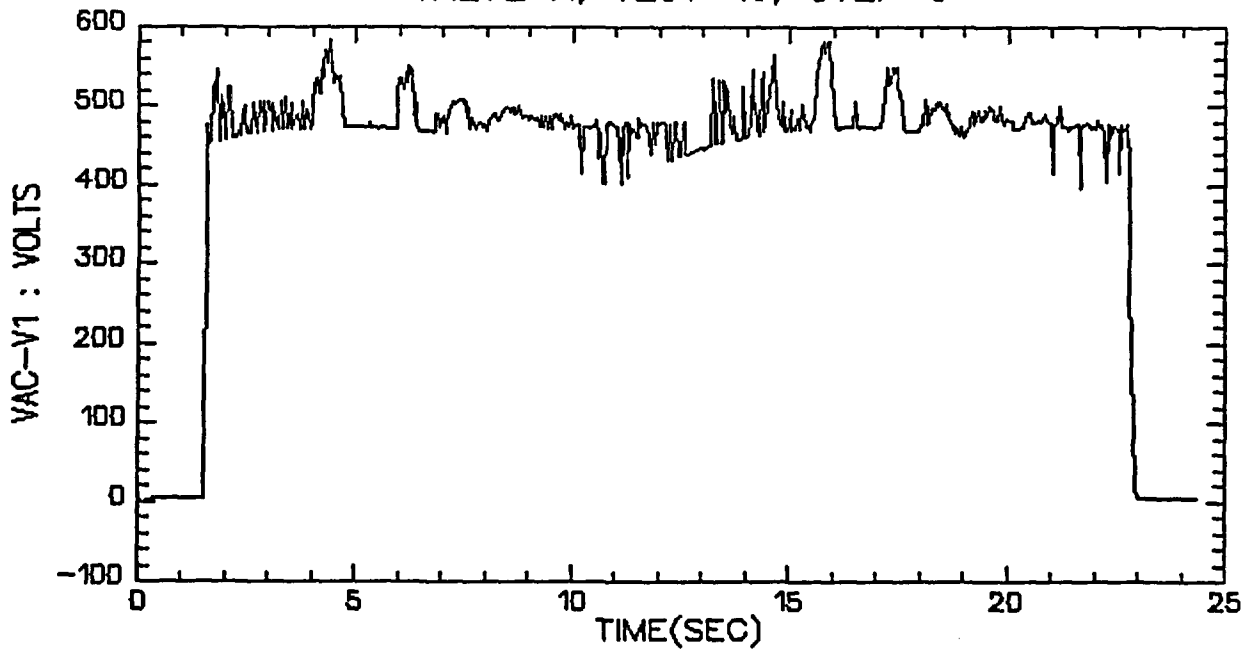

VALVE A, TEST 10, STEP 5

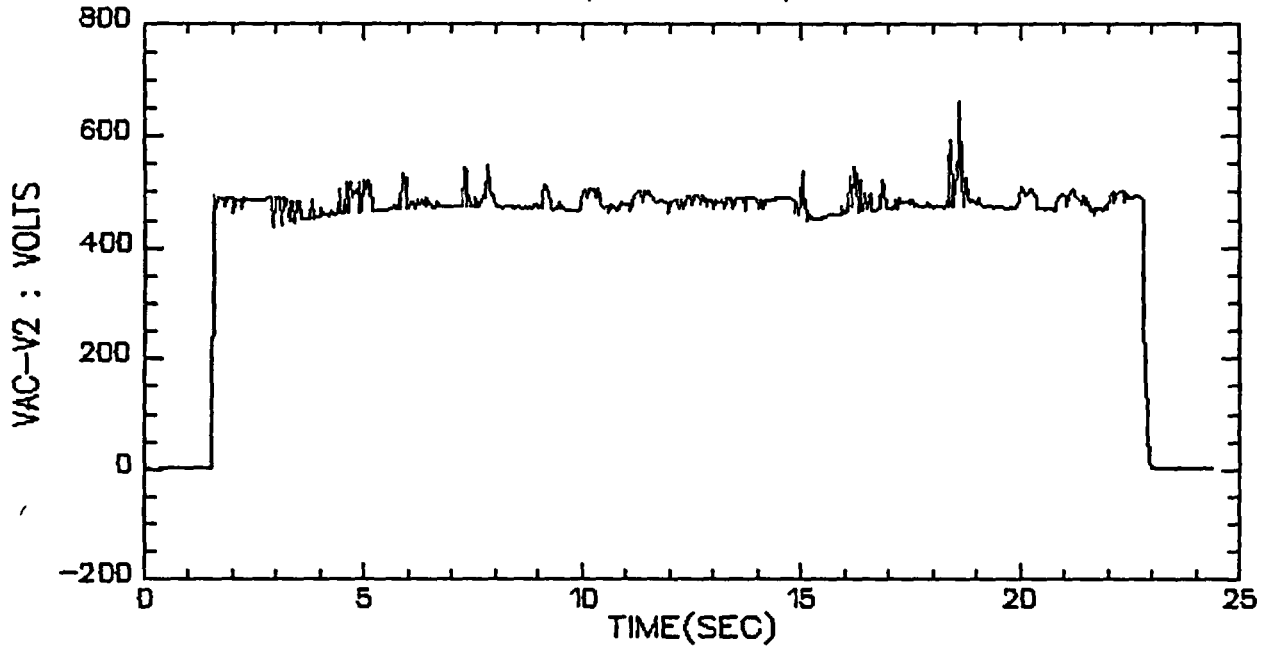

VALVE A, TEST 10, STEP 5

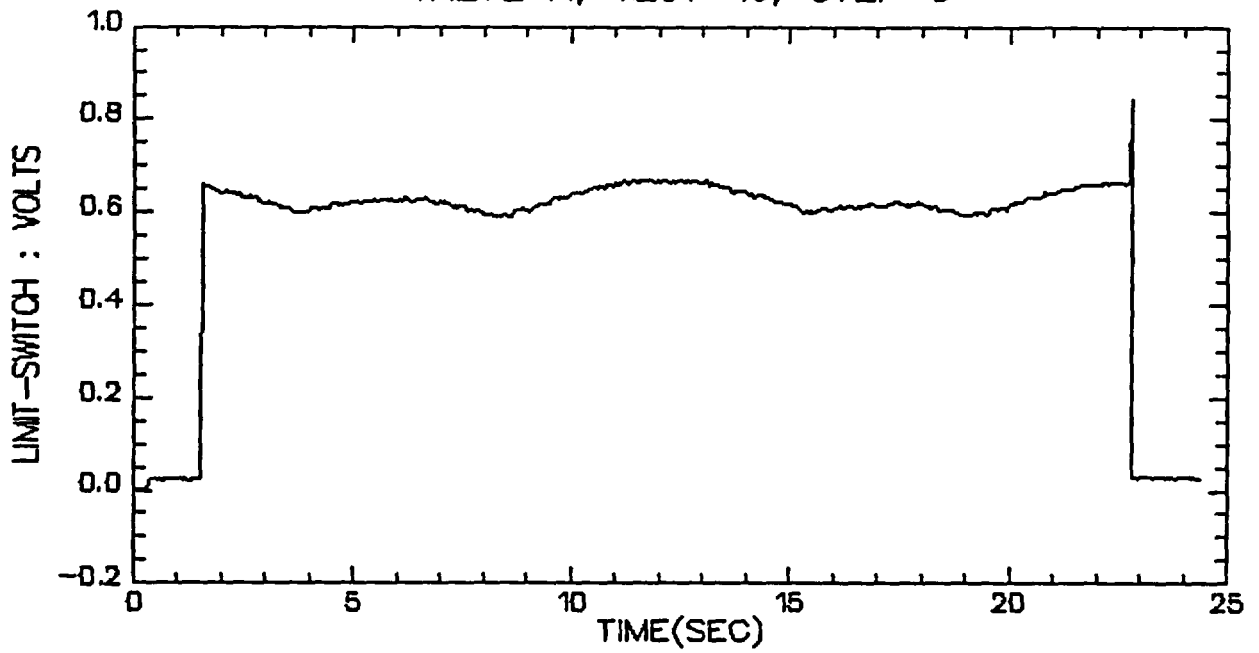

VALVE A, TEST 10, STEP 5

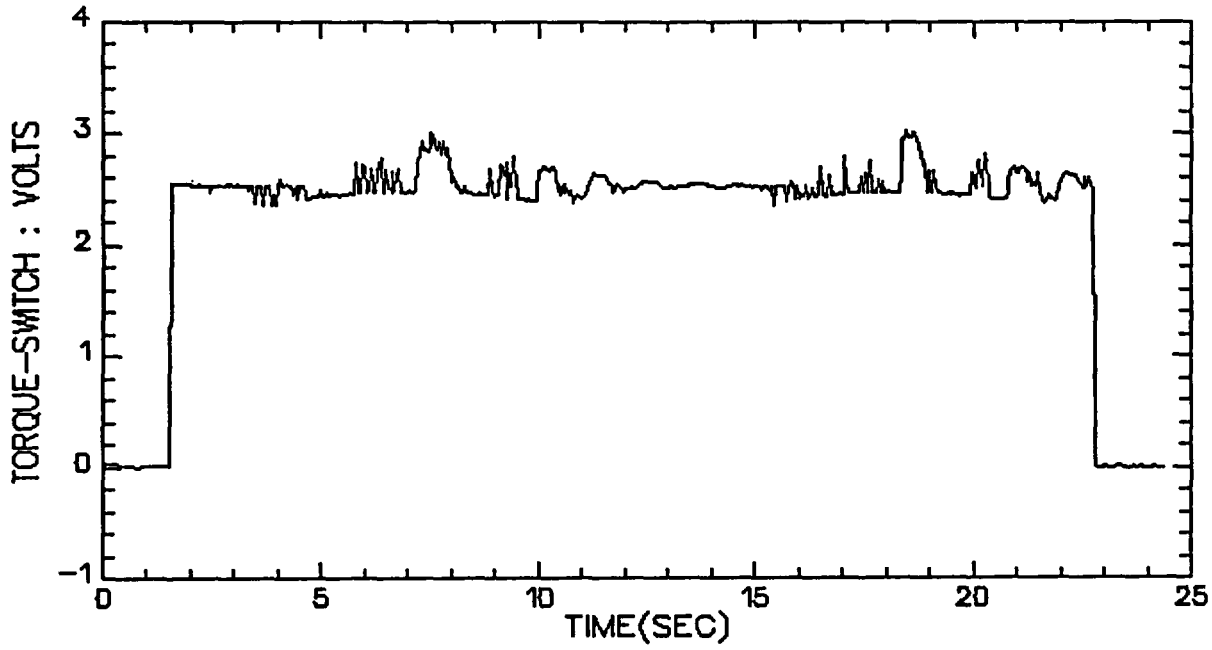

VALVE A, TEST 10, STEP 5

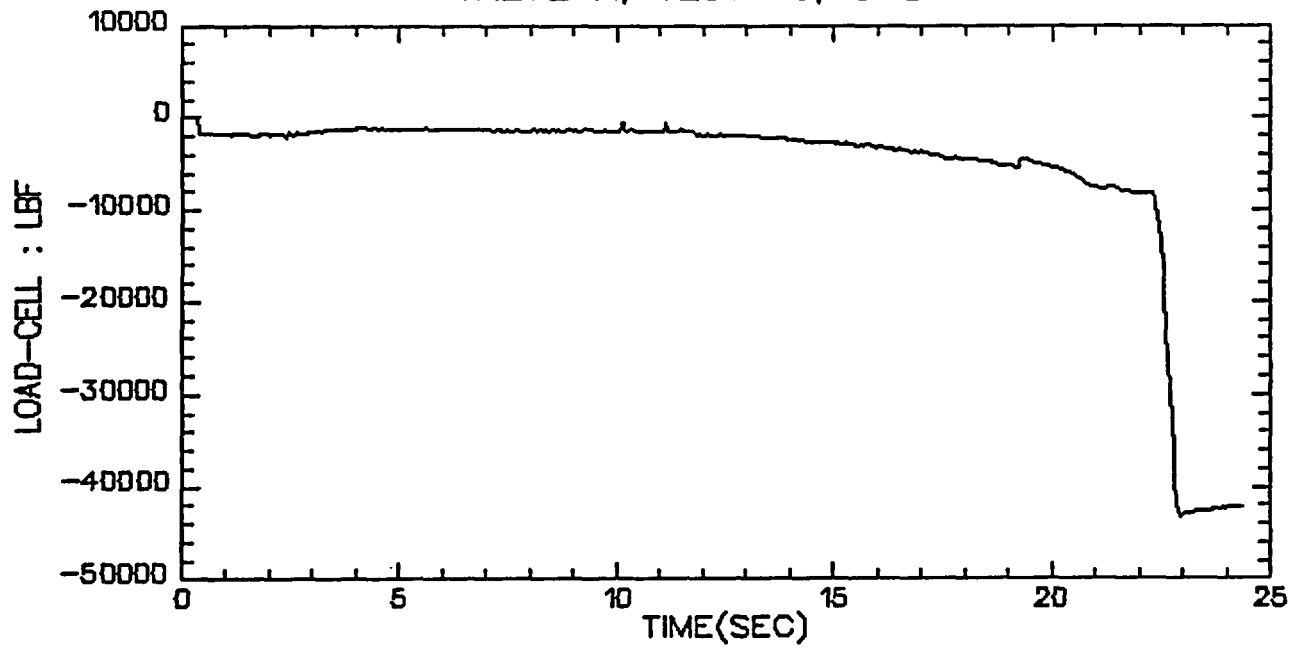

VALVE A, TEST 10, STEP 6&7

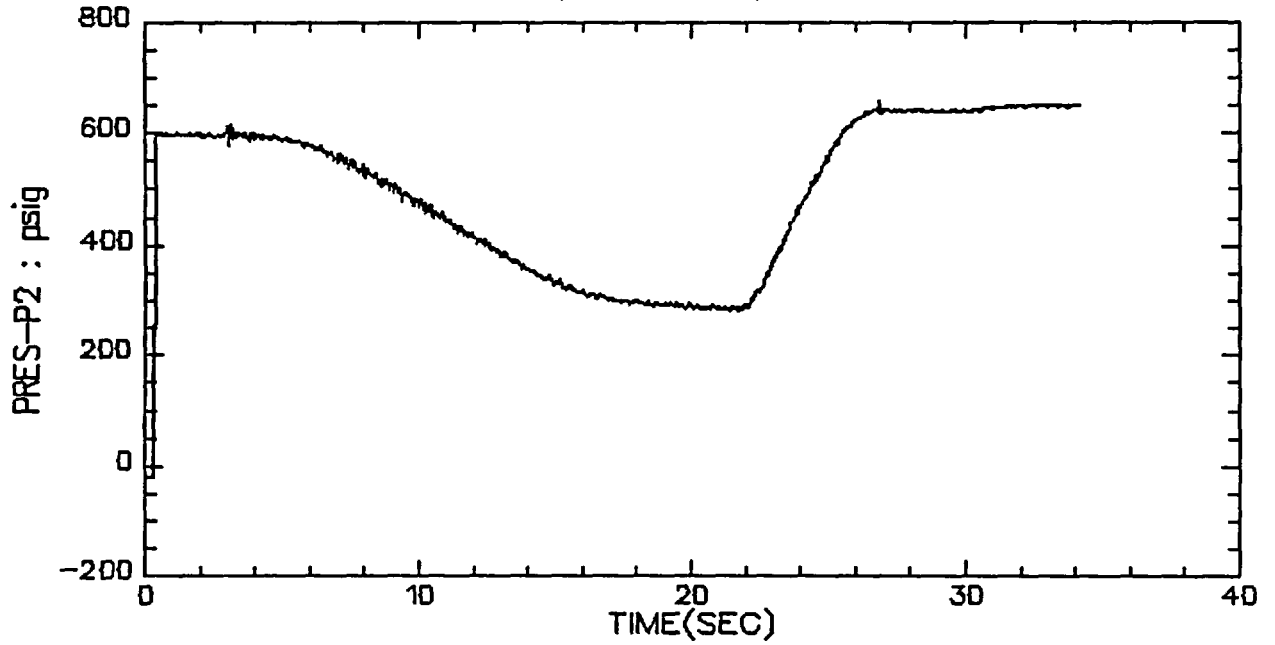

VALVE A, TEST 10, STEP 6&7

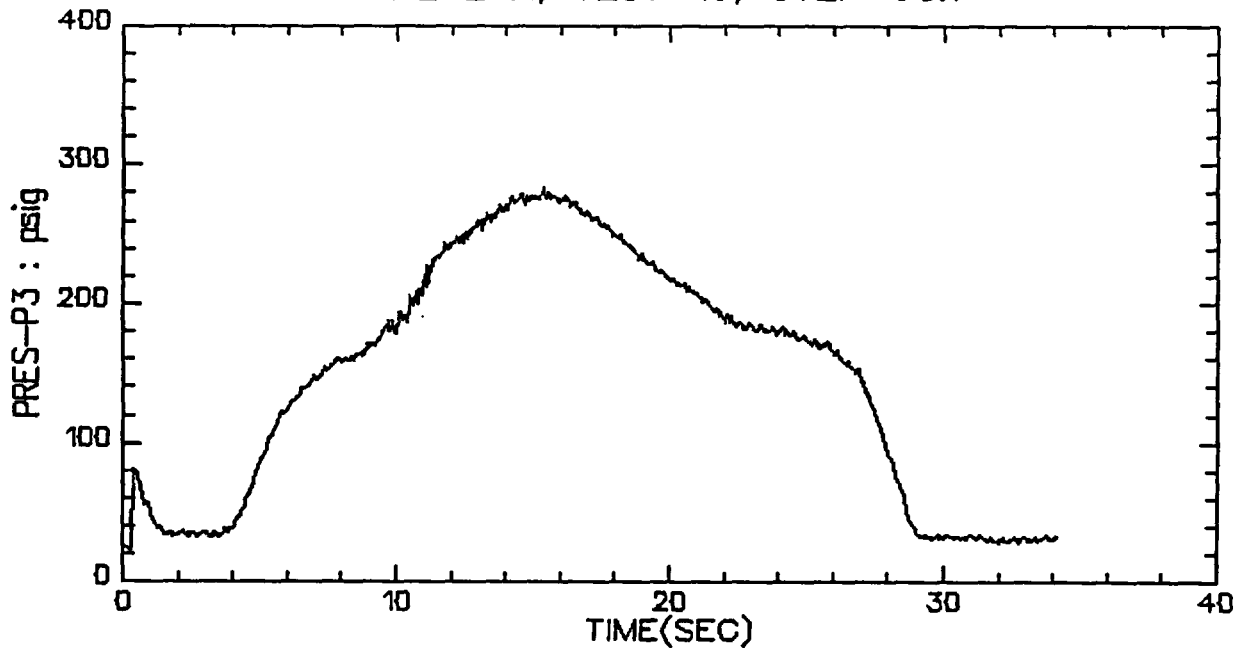

VALVE A, TEST 10, STEP 6&7

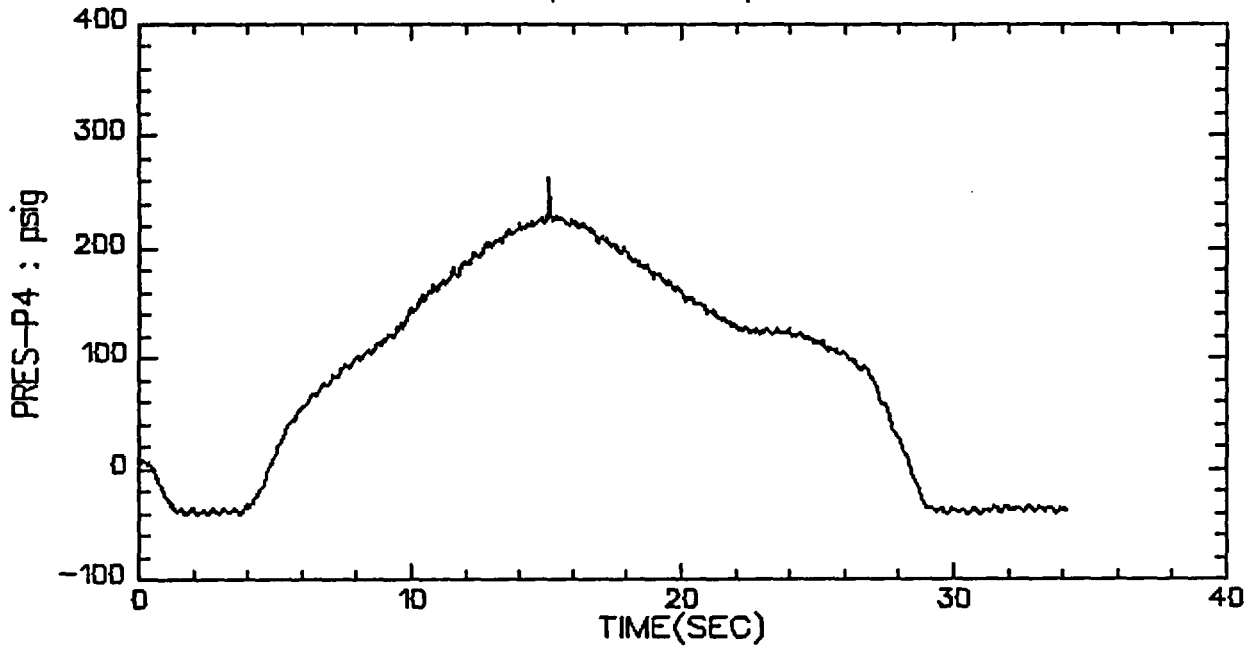

VALVE A, TEST 10, STEP 6&7

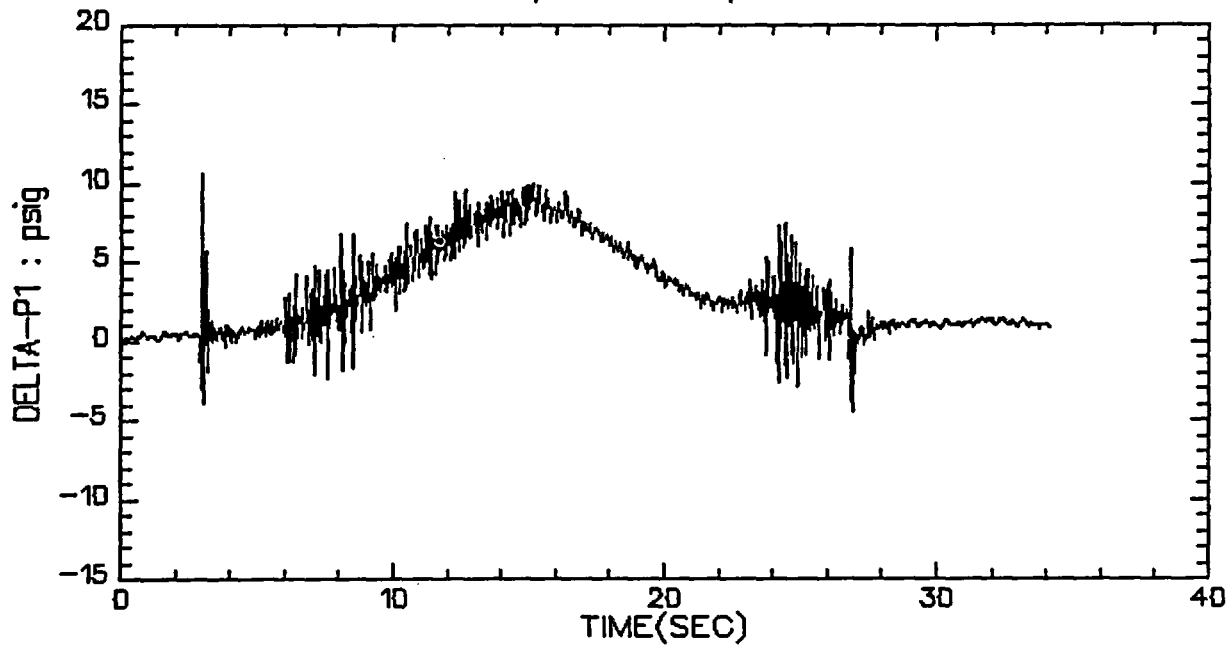

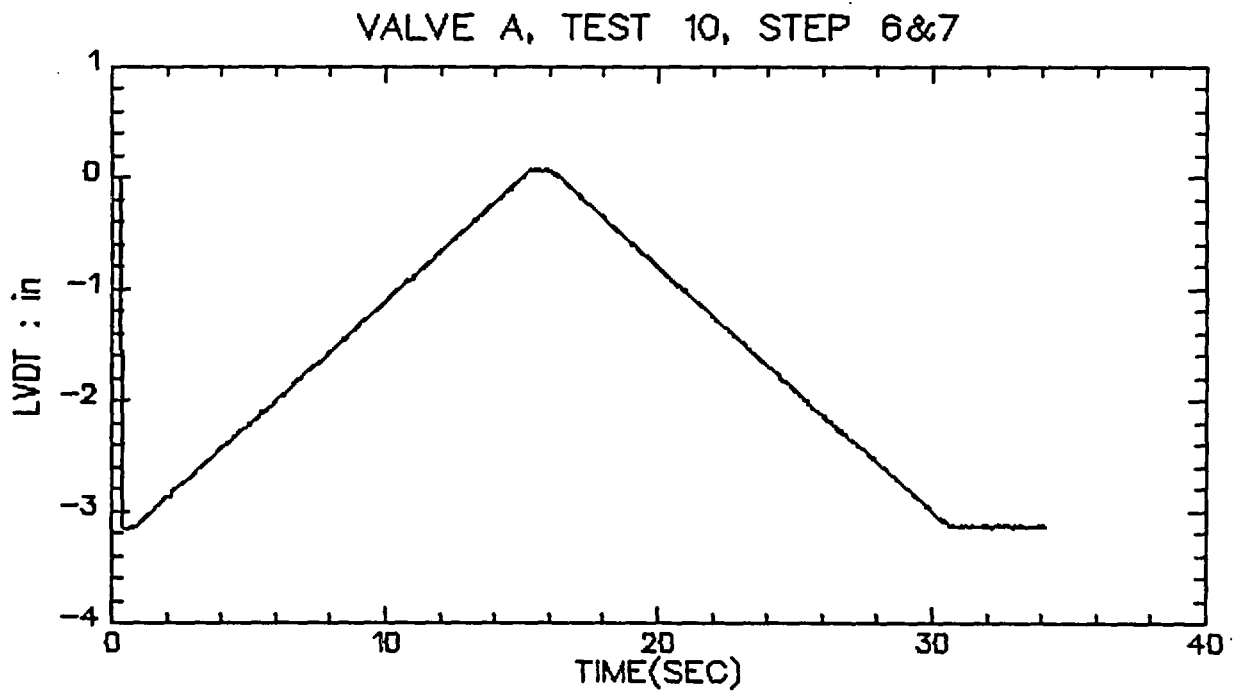
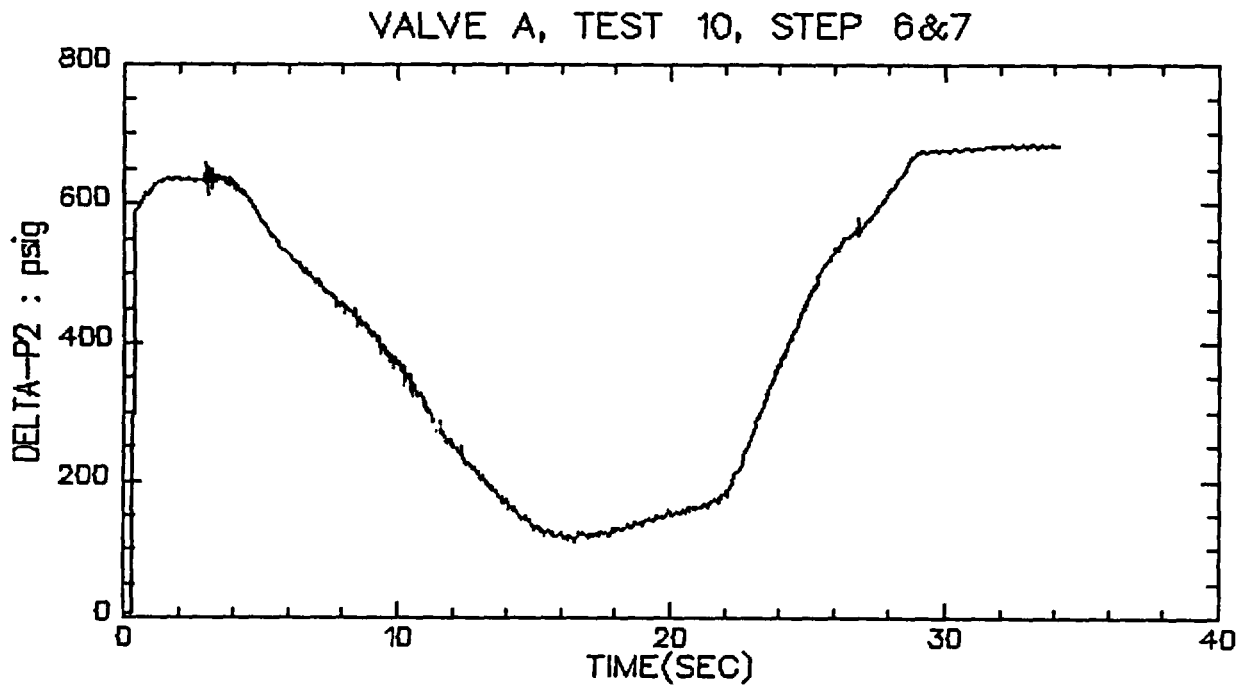

VALVE A, TEST 10, STEP 6&7

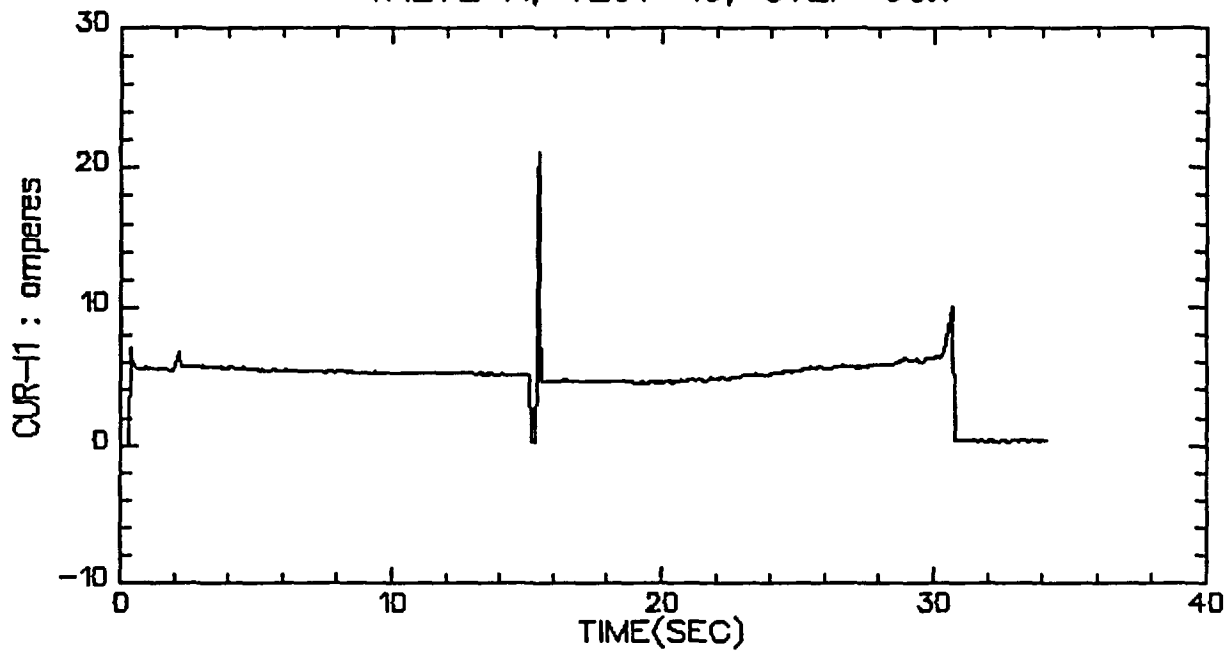

VALVE A, TEST 10, STEP 6&7

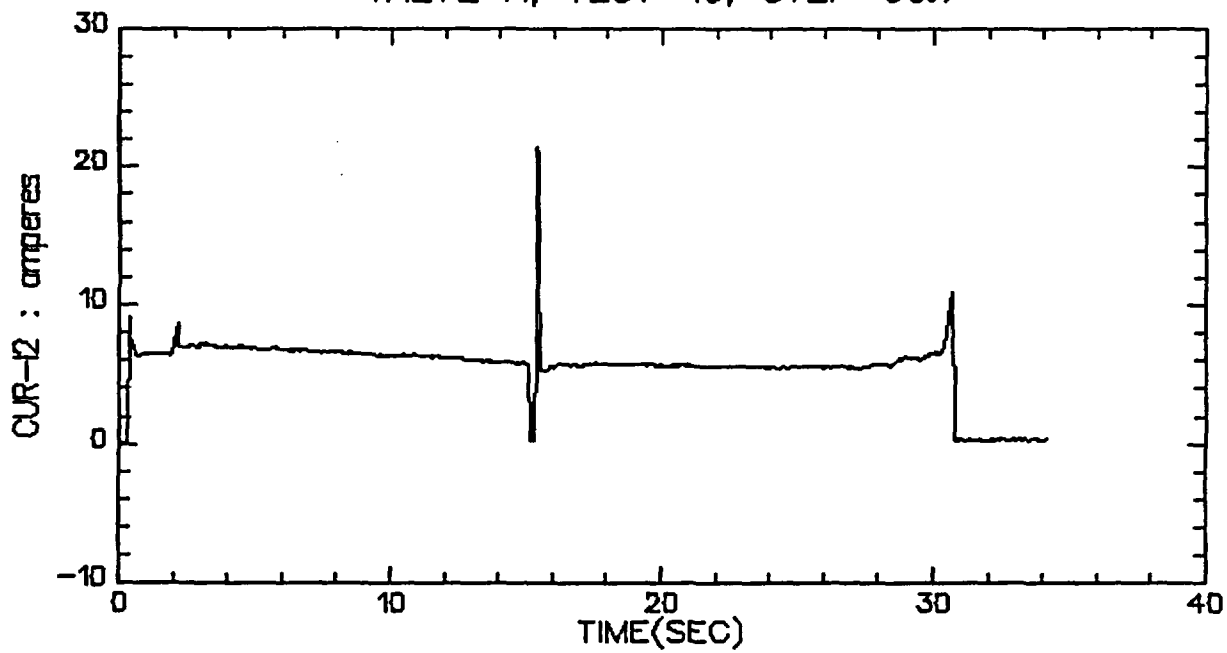

VALVE A, TEST 10, STEP 6&7

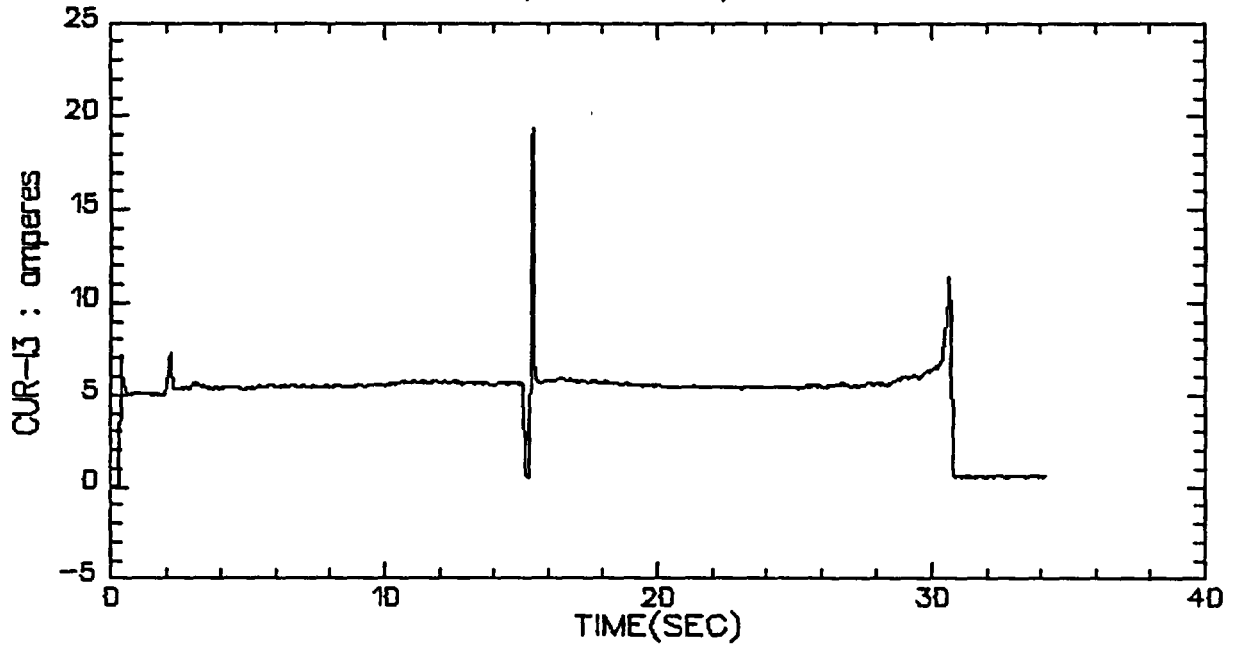

VALVE A, TEST 10, STEP 6&7

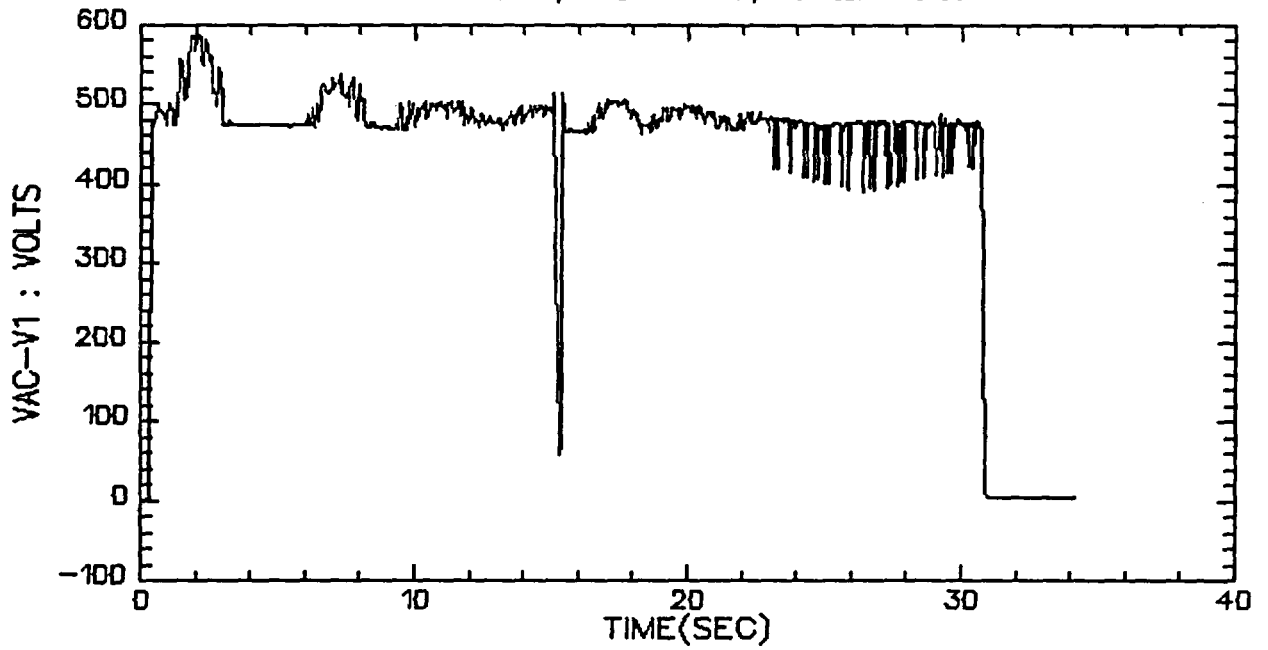

VALVE A, TEST 10, STEP 6&7

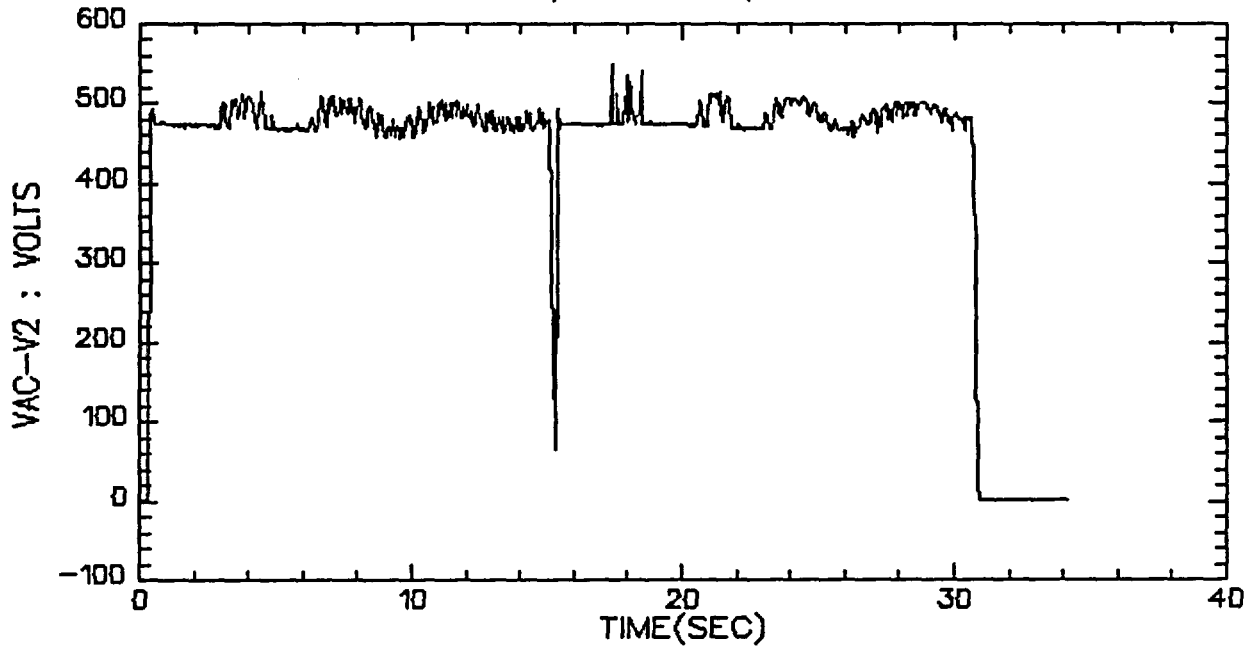

VALVE A, TEST 10, STEP 6&7

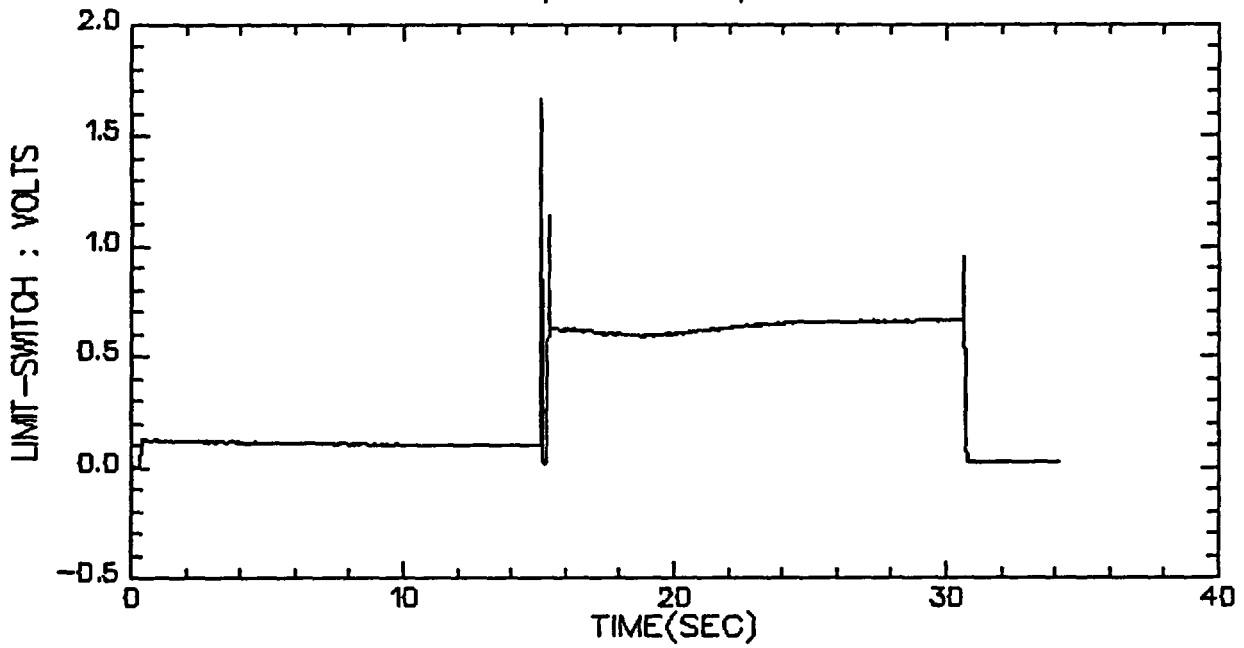

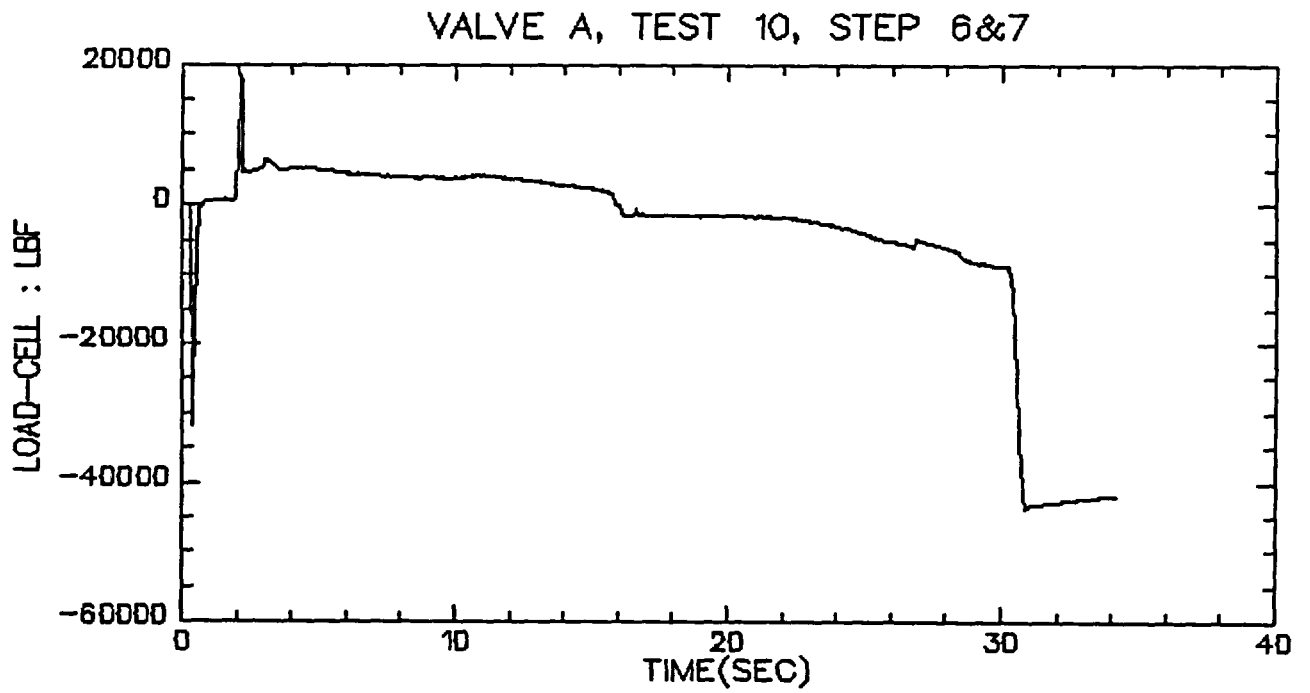
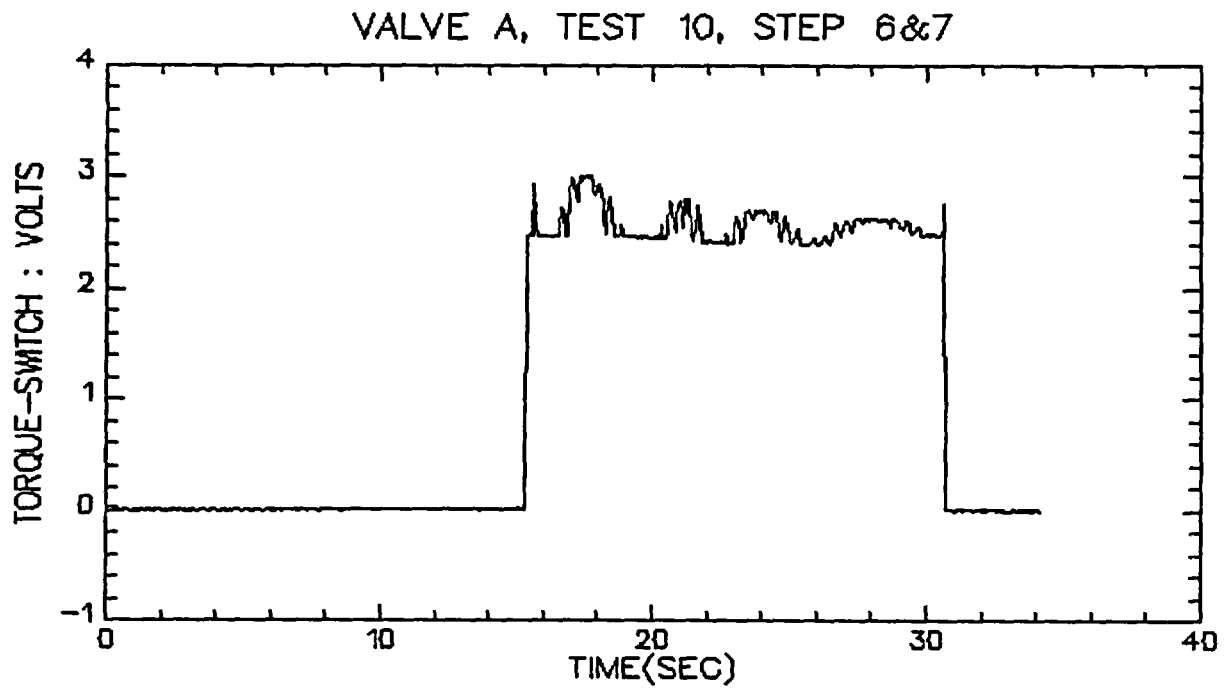

VALVE A, TEST 10, STEP 8&9

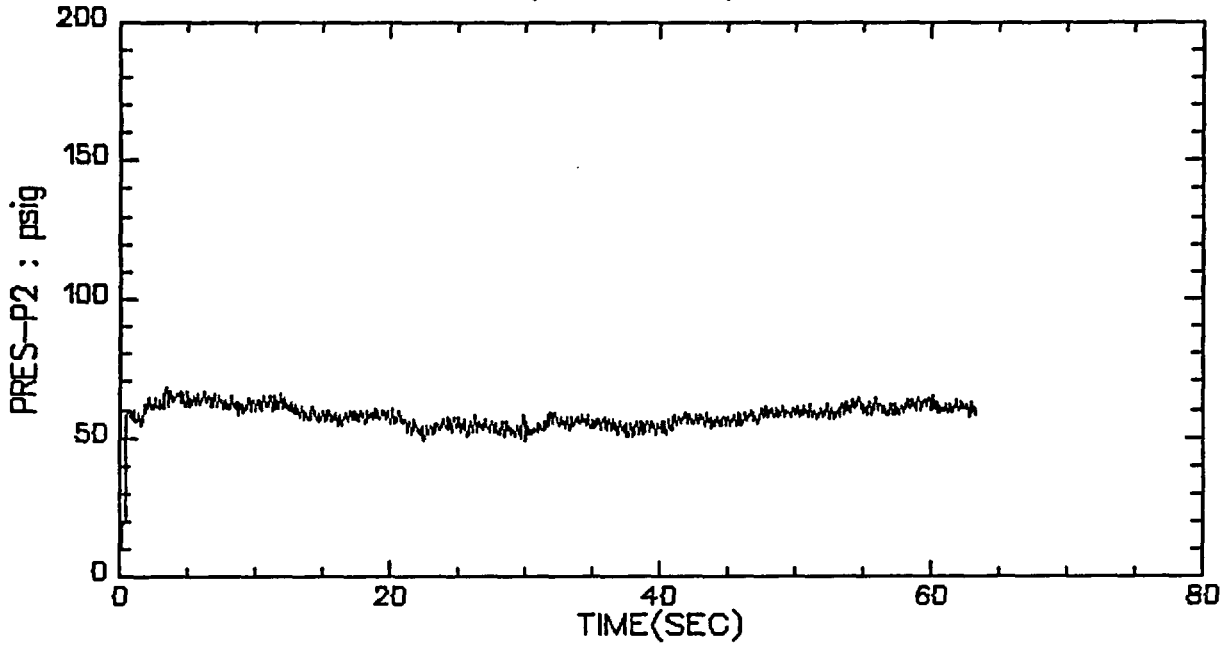

VALVE A, TEST 10, STEP 8&9

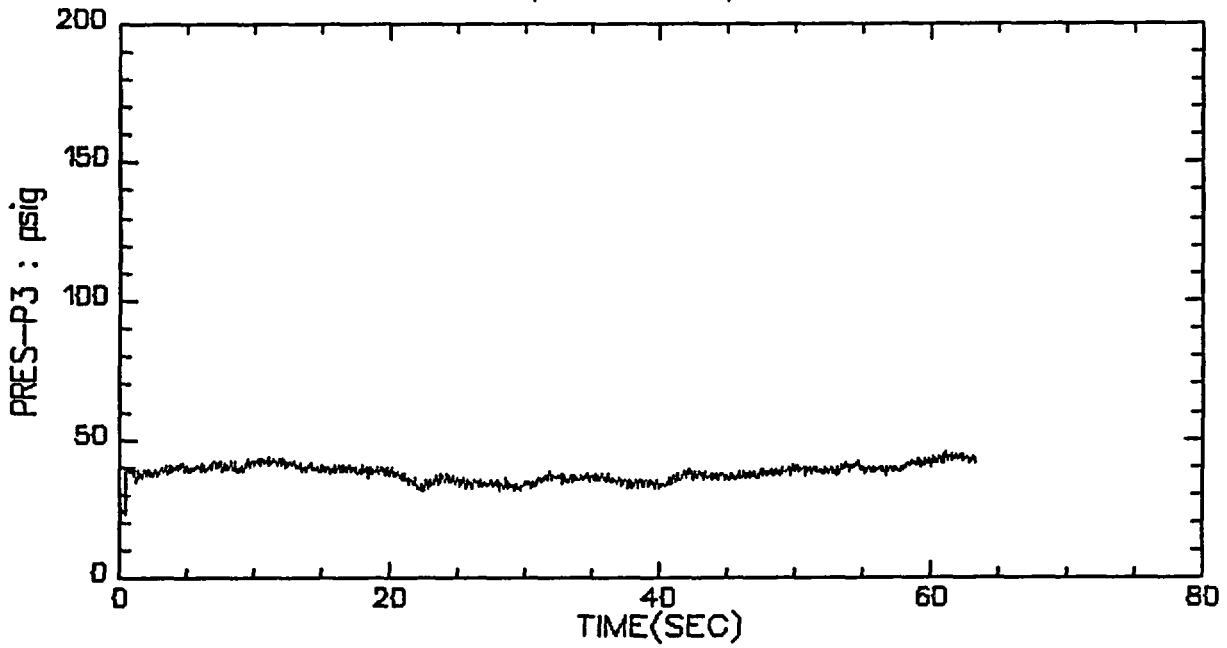

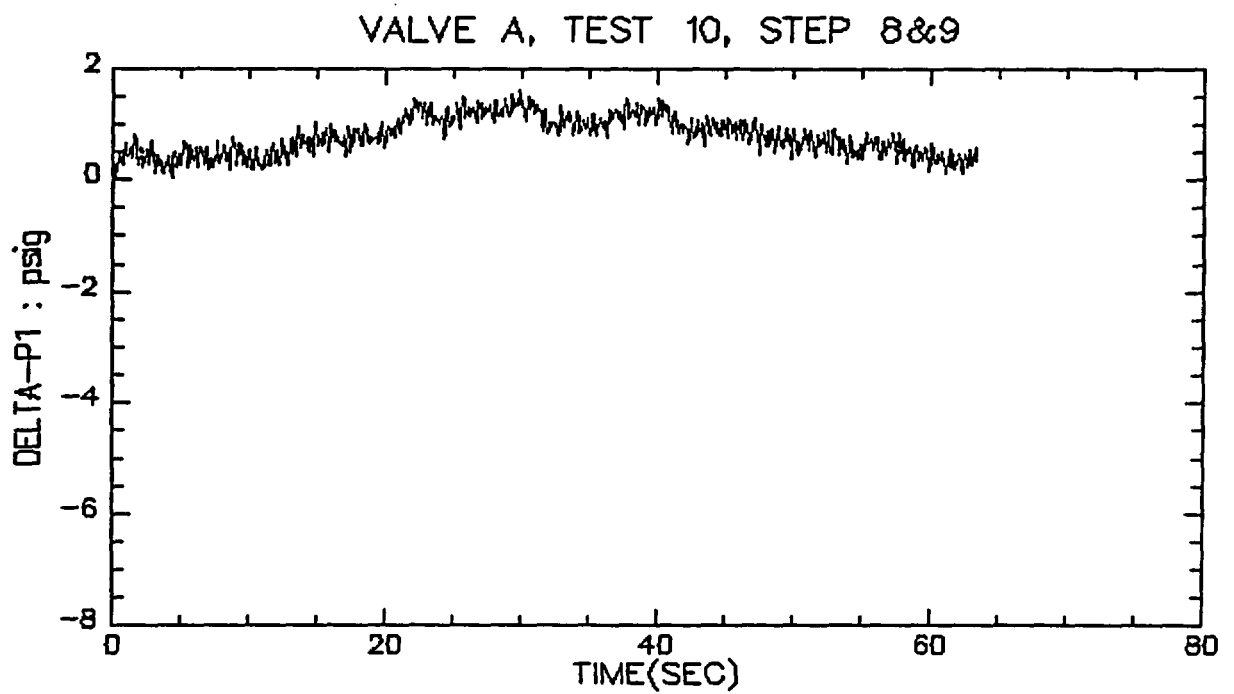
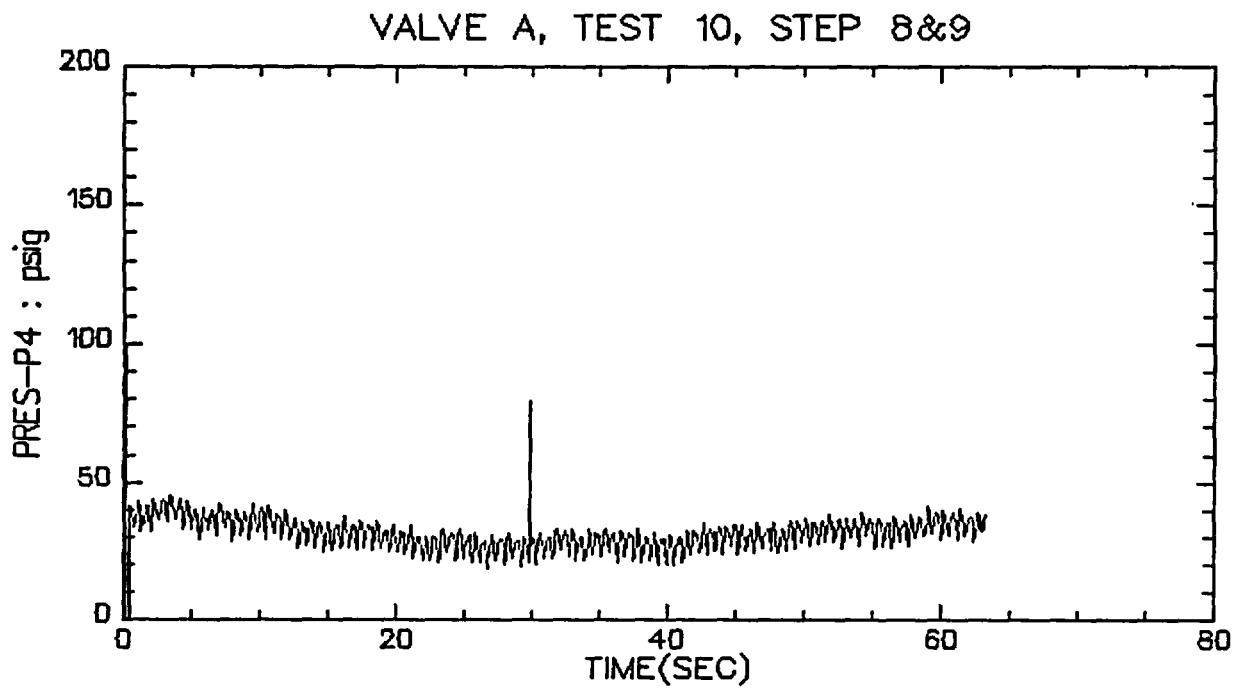

VALVE A, TEST 10, STEP 8&9

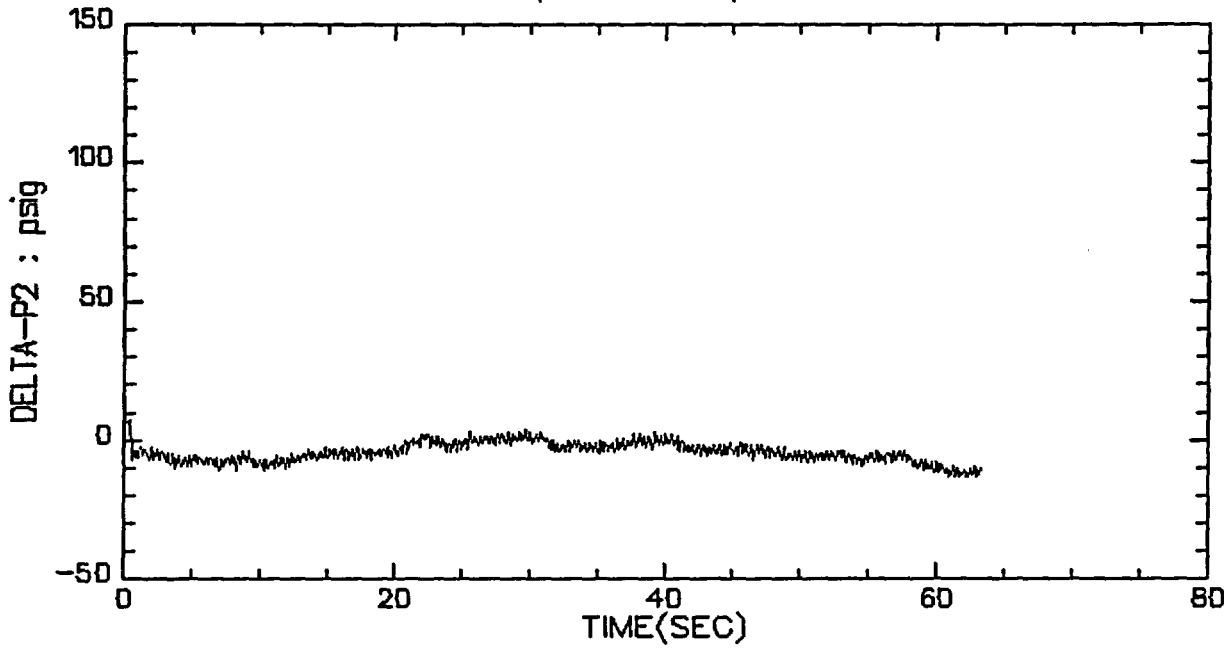

VALVE A, TEST 10, STEP 8&9

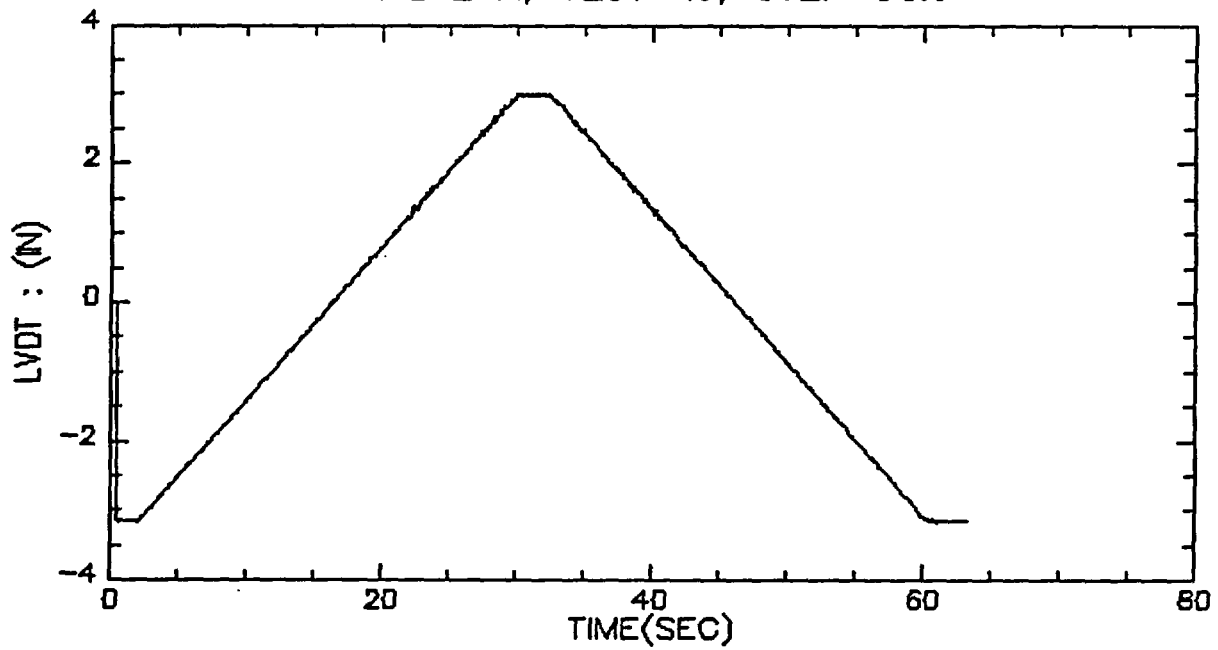

VALVE A, TEST 10, STEP 8&9

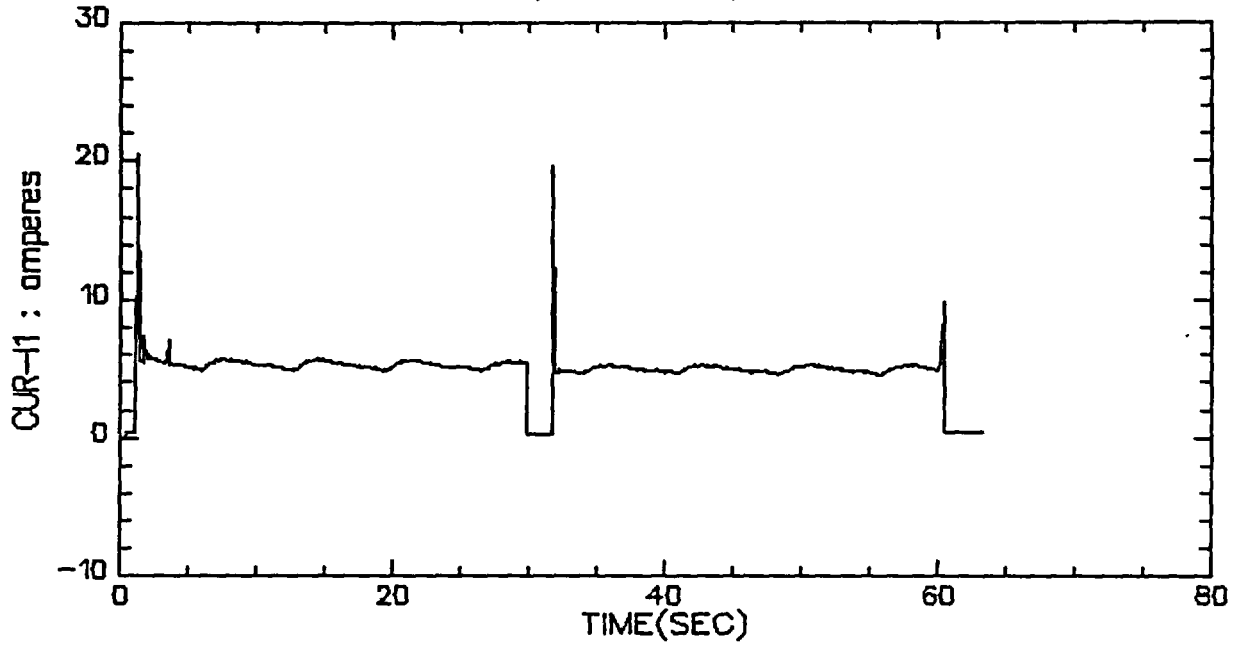

VALVE A, TEST 10, STEP 8&9

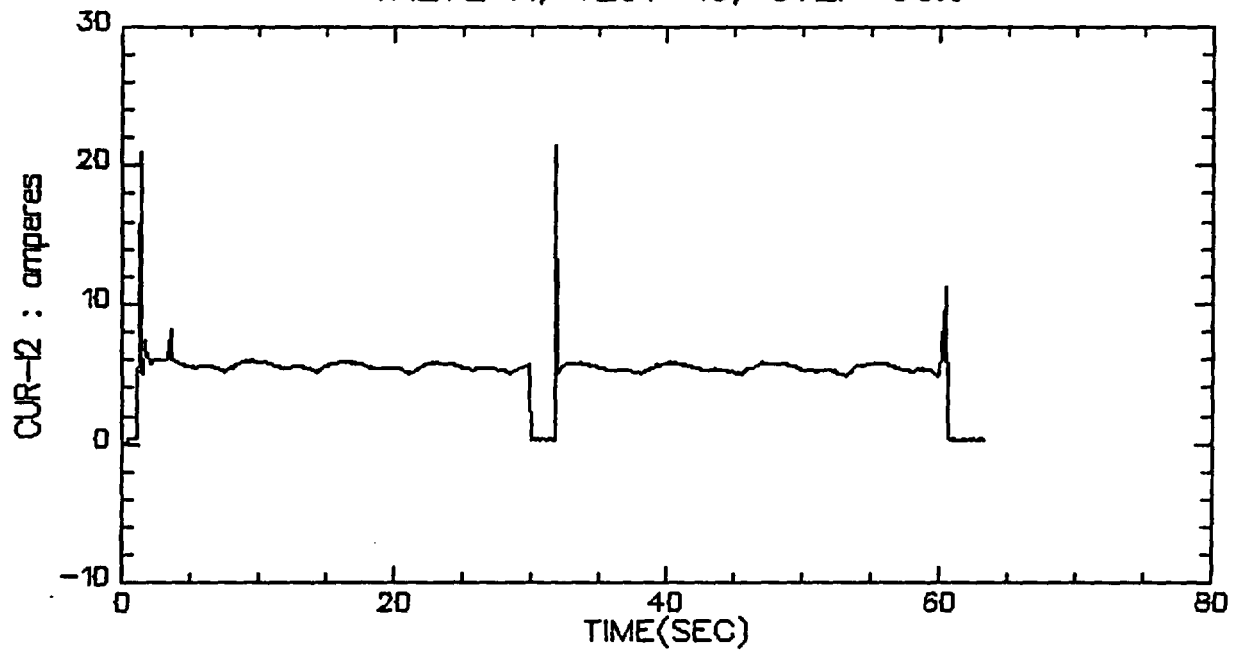

VALVE A, TEST 10, STEP 8&9

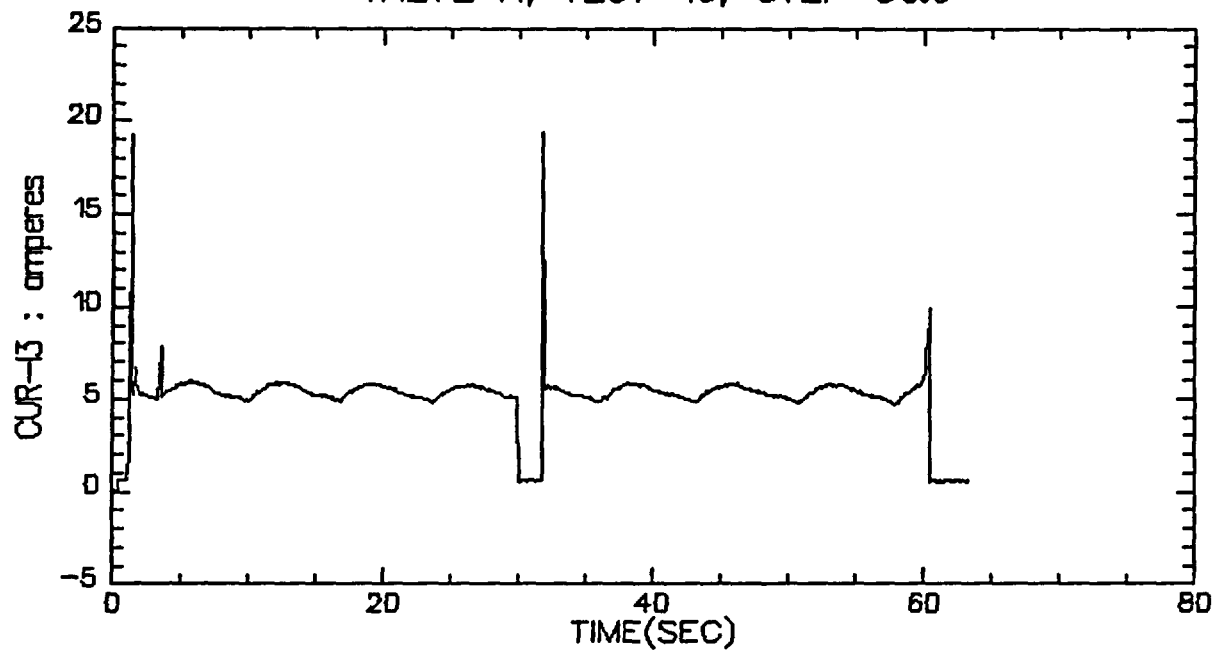

VALVE A, TEST 10, STEP 8&9

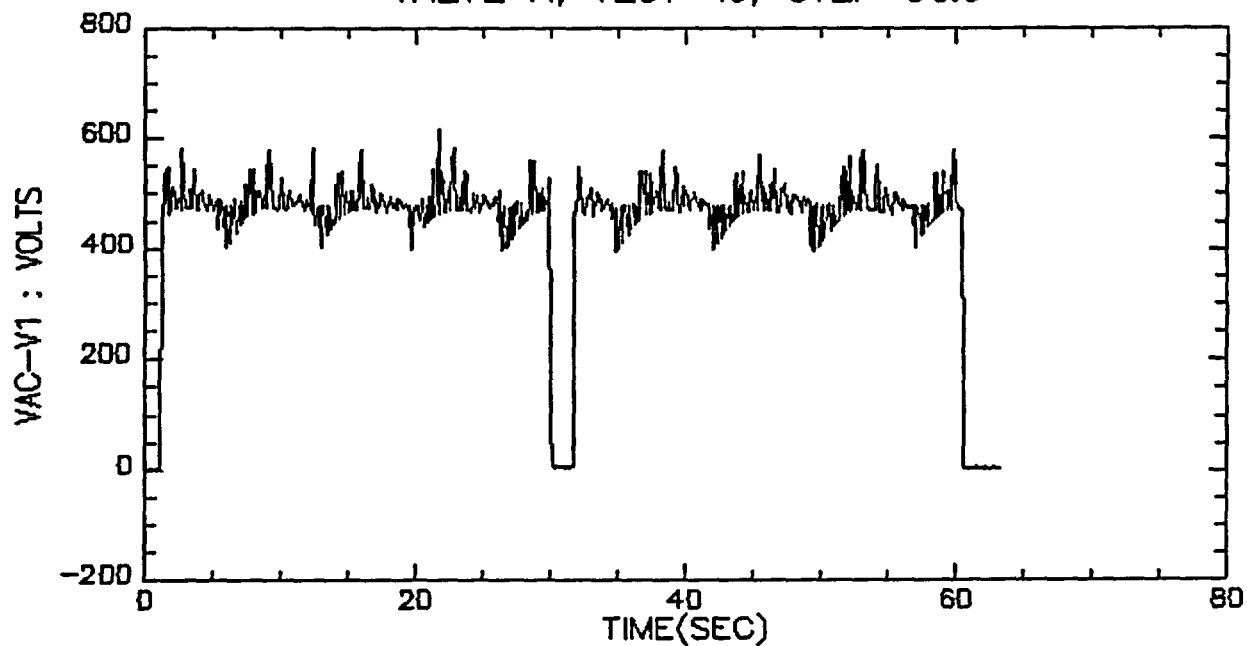

VALVE A, TEST 10, STEP 8&9

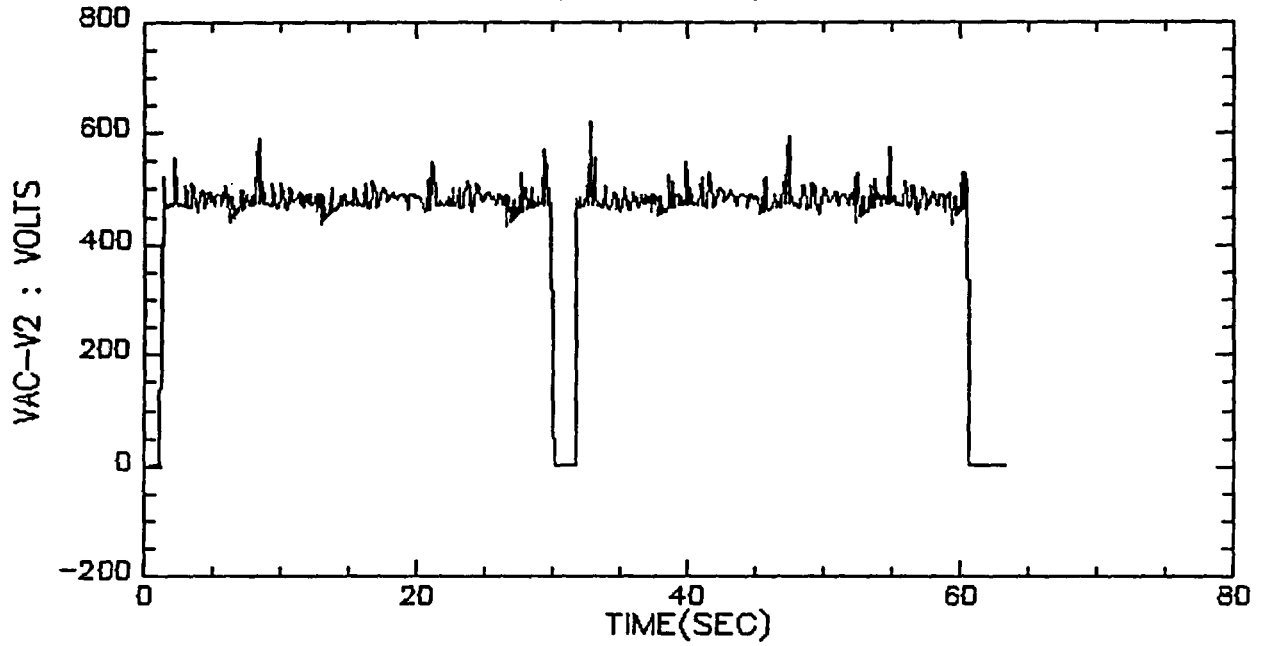

VALVE A, TEST 10, STEP 8&9

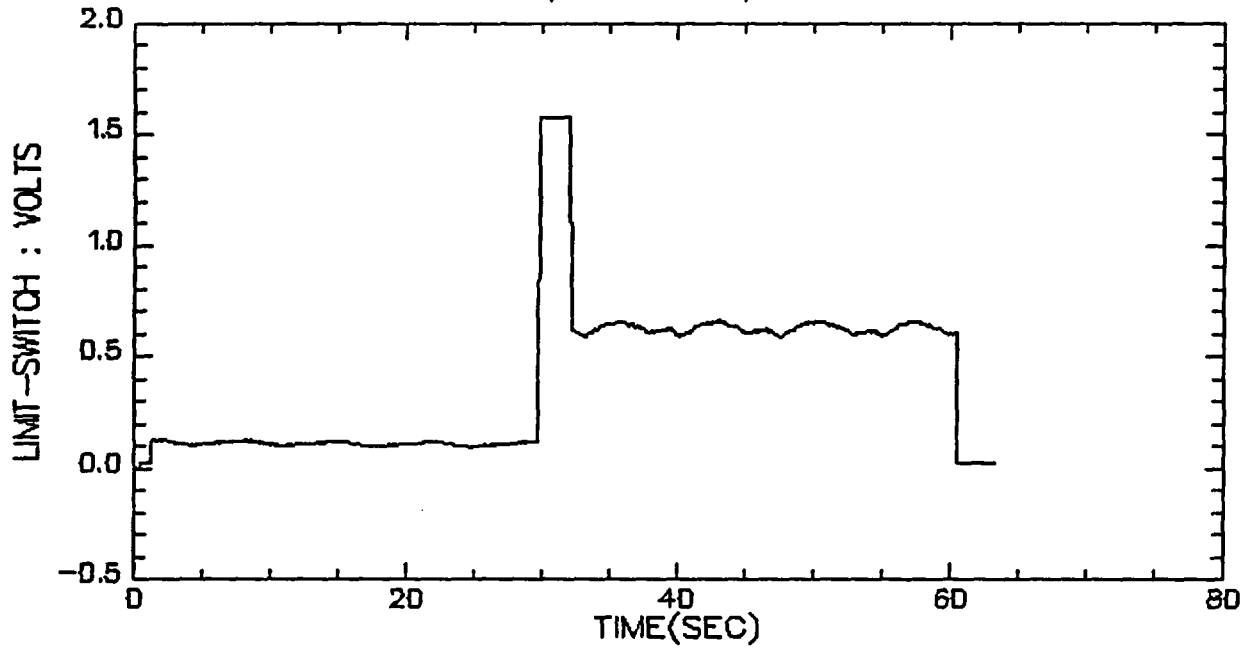

VALVE A, TEST 10, STEP 8&9

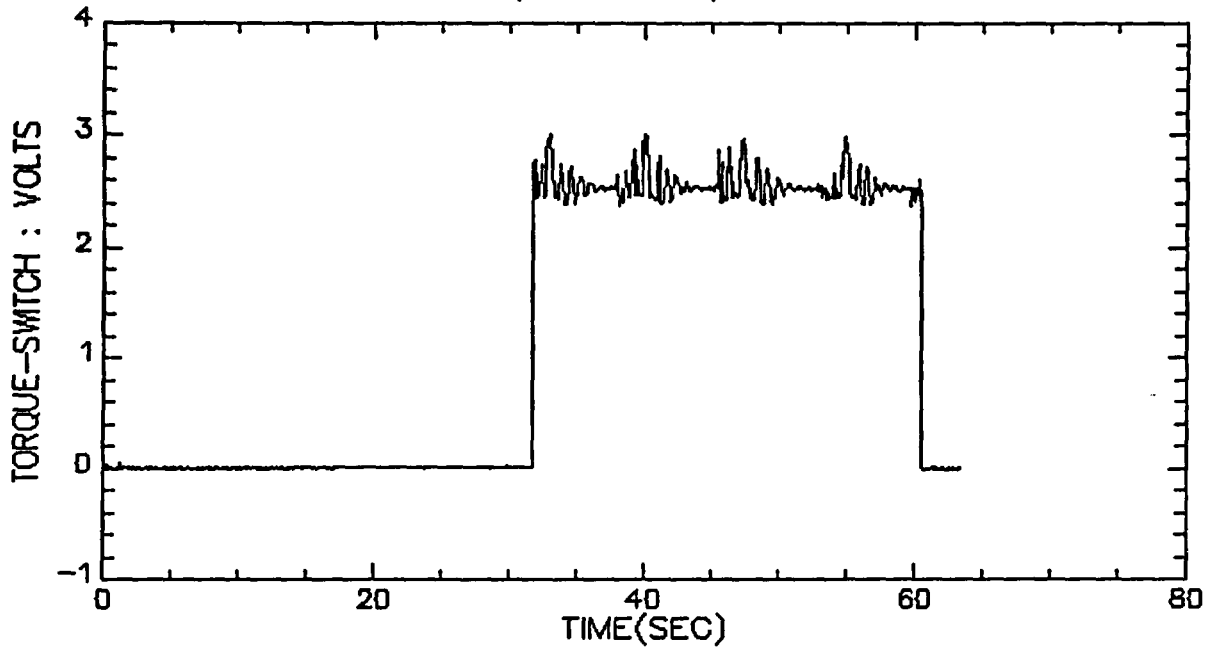

VALVE A, TEST 10, STEP 8&9

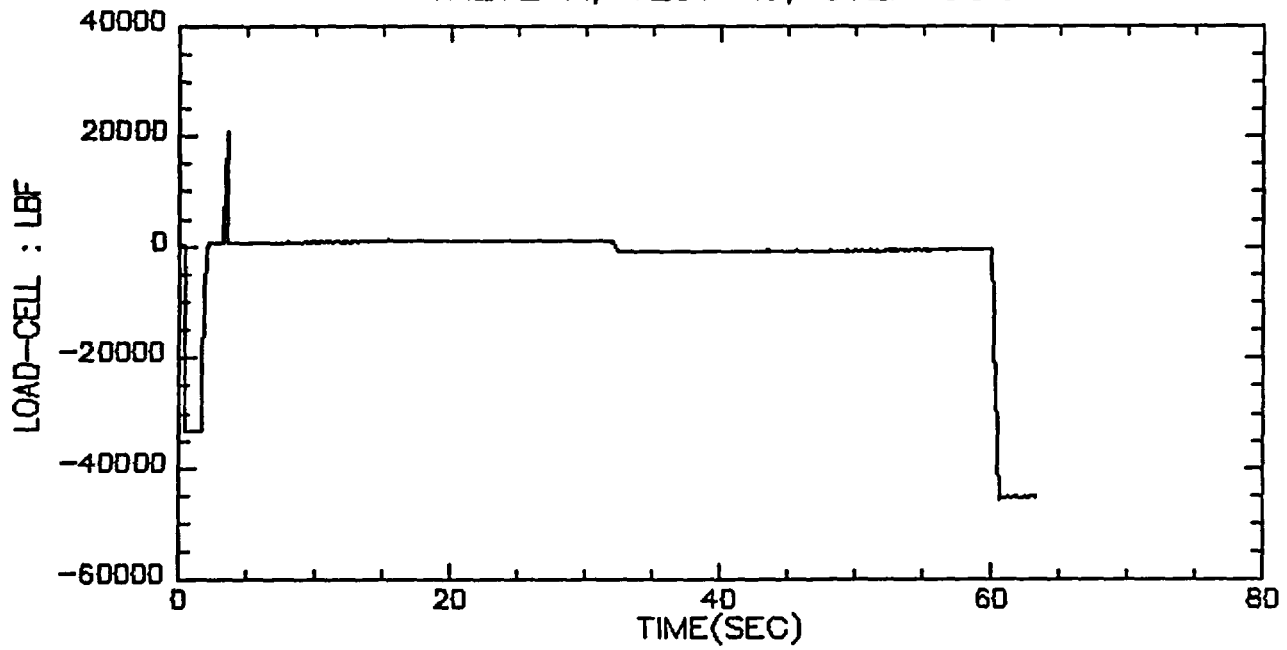

VALVE A, TEST 11, STEP 1

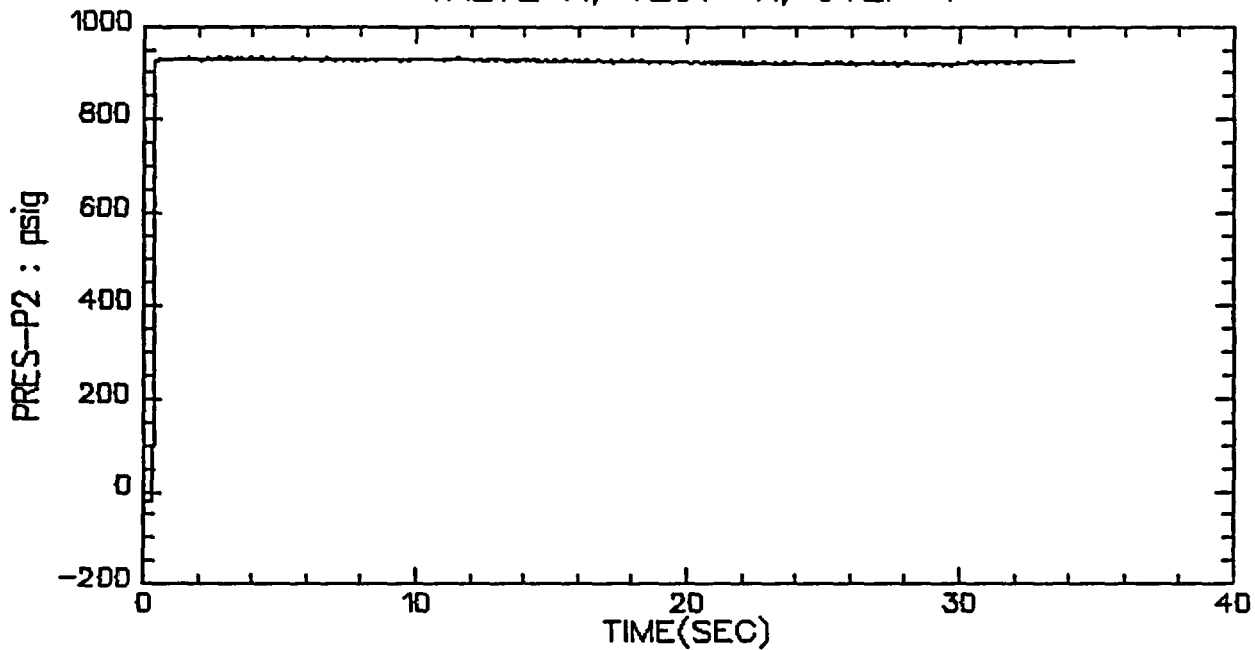

VALVE A, TEST 11, STEP 1

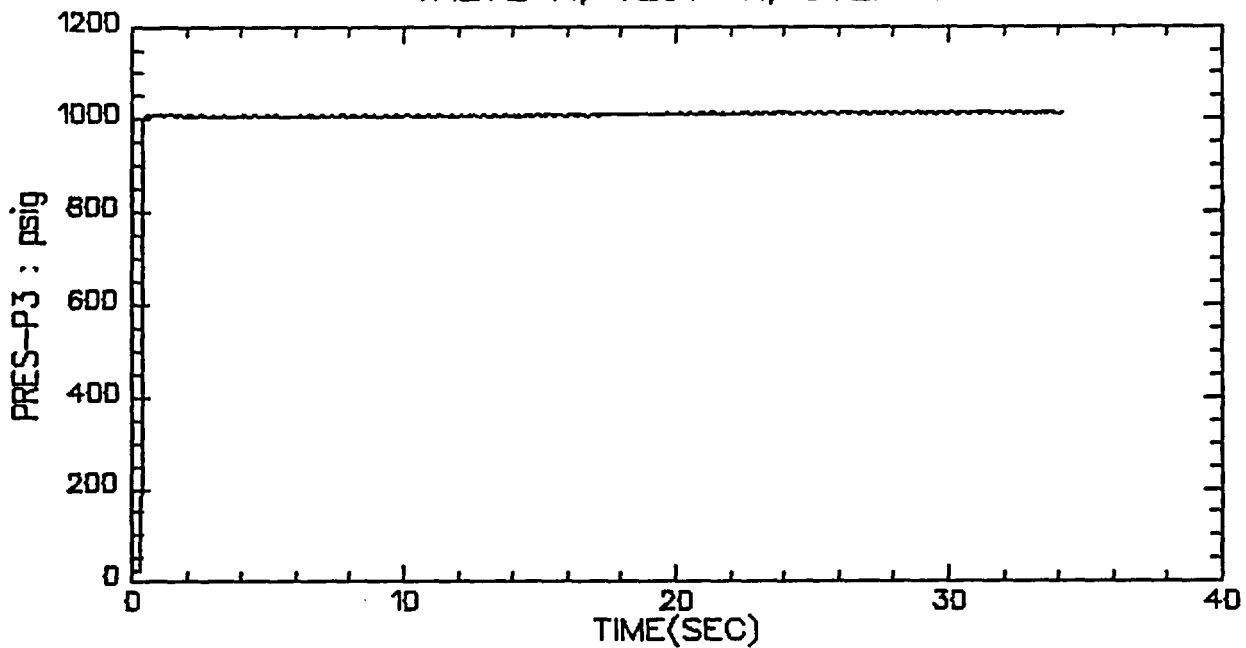

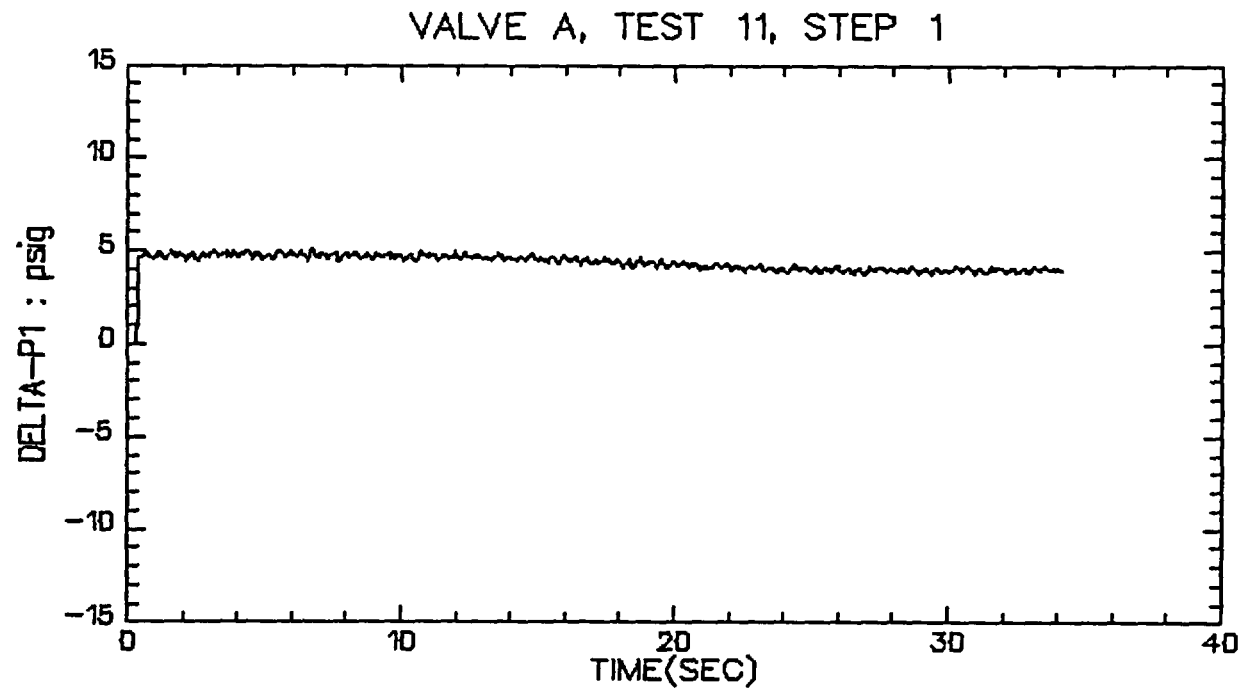
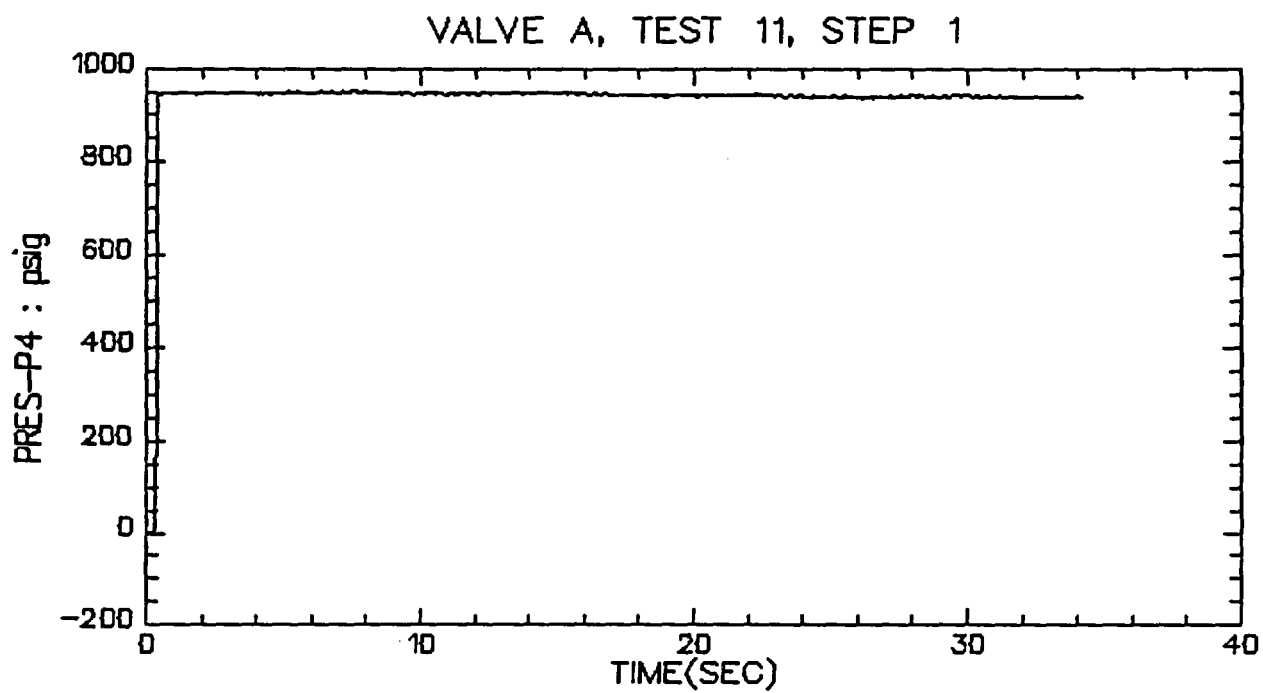

VALVE A, TEST 11, STEP 1

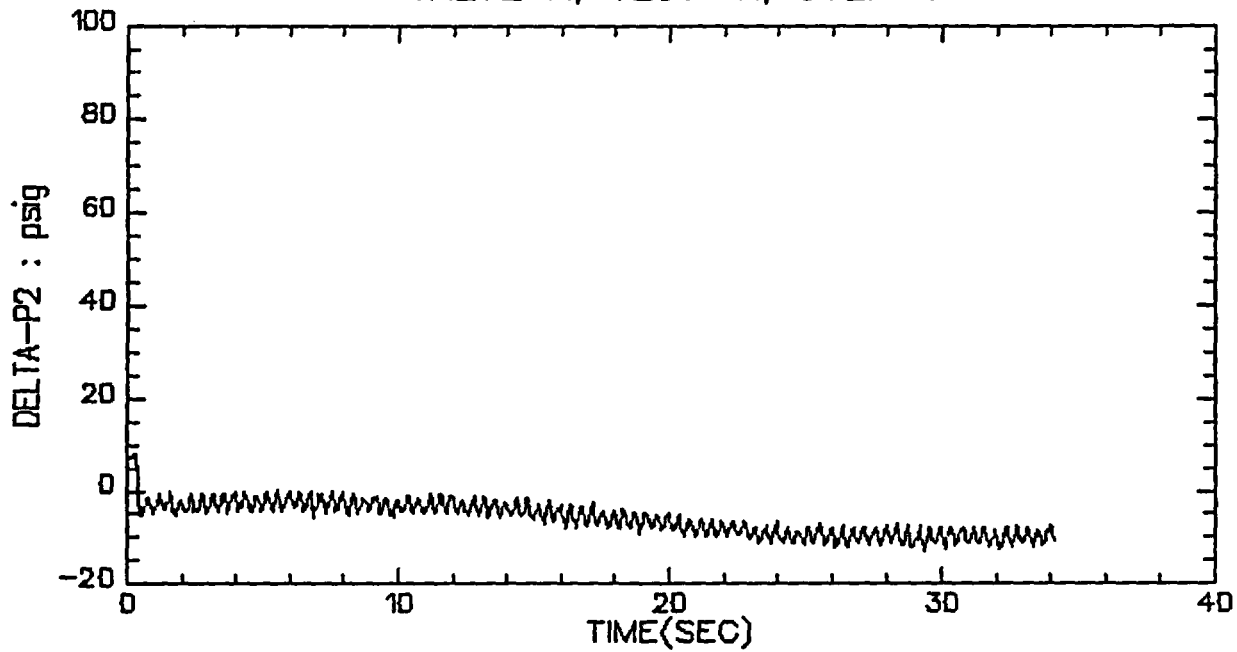

VALVE A, TEST 11, STEP 1

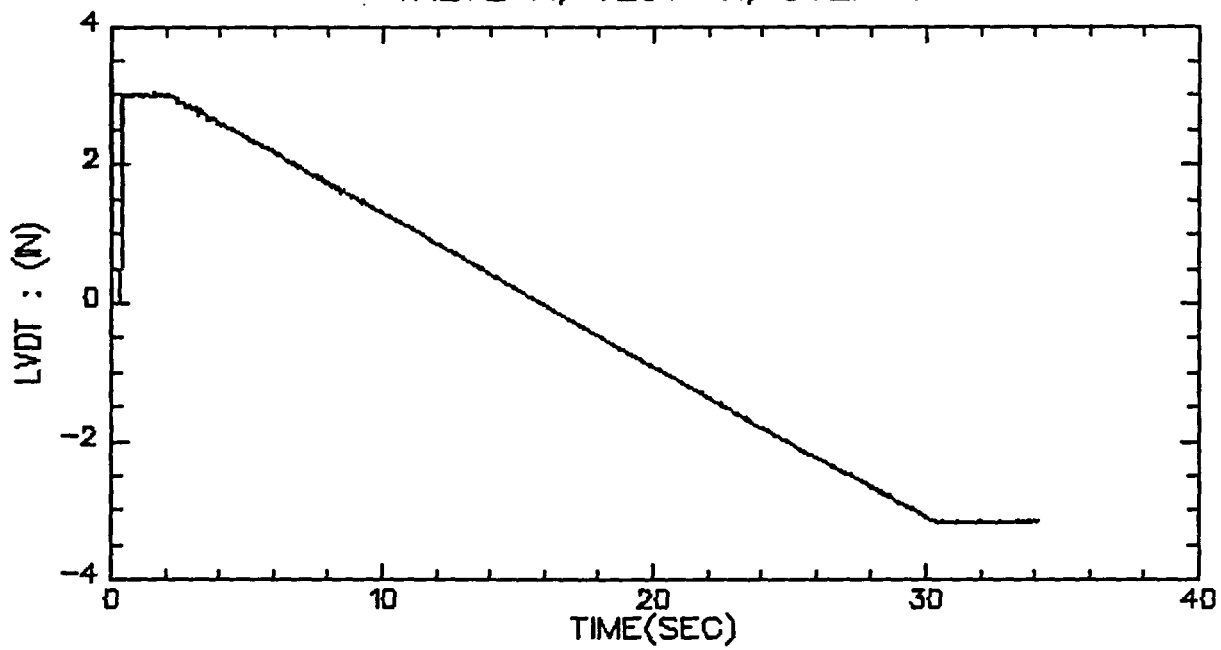

VALVE A, TEST 11, STEP 1

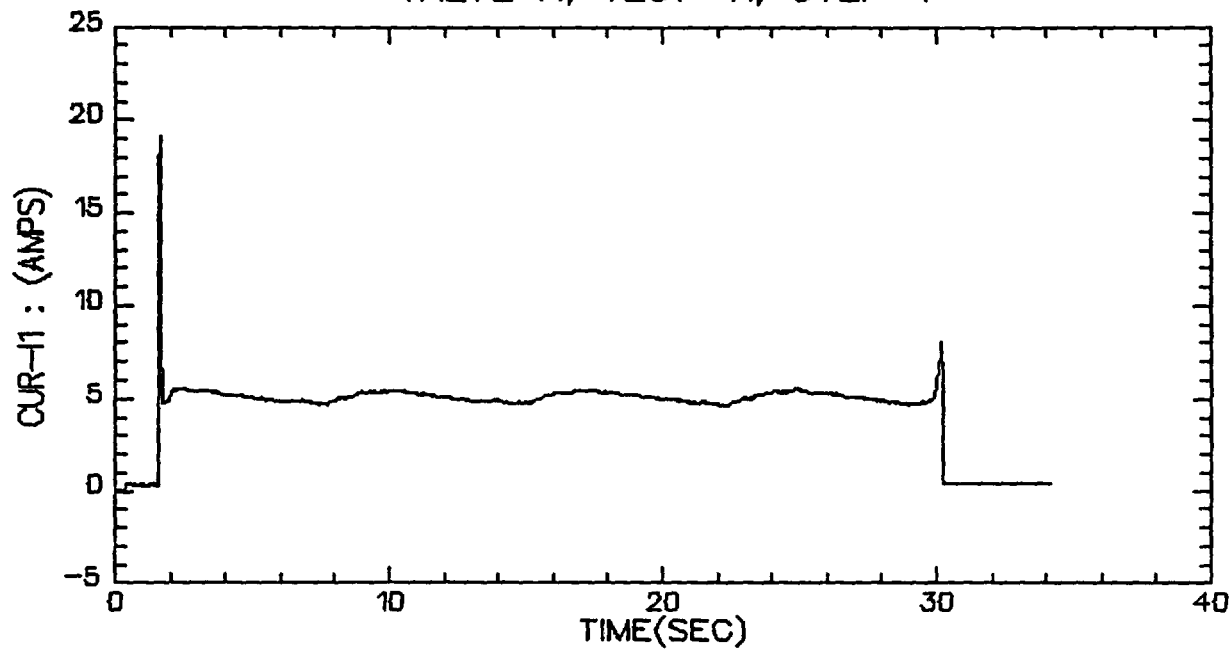

VALVE A, TEST 11, STEP 1

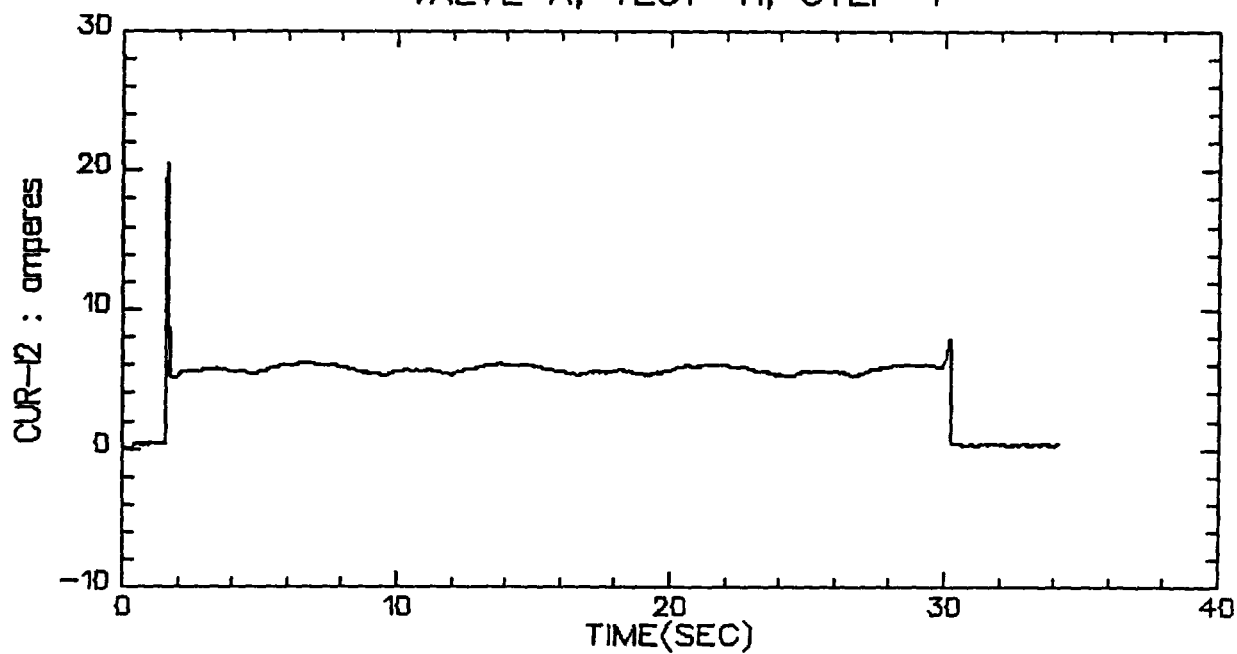

VALVE A, TEST 11, STEP 1

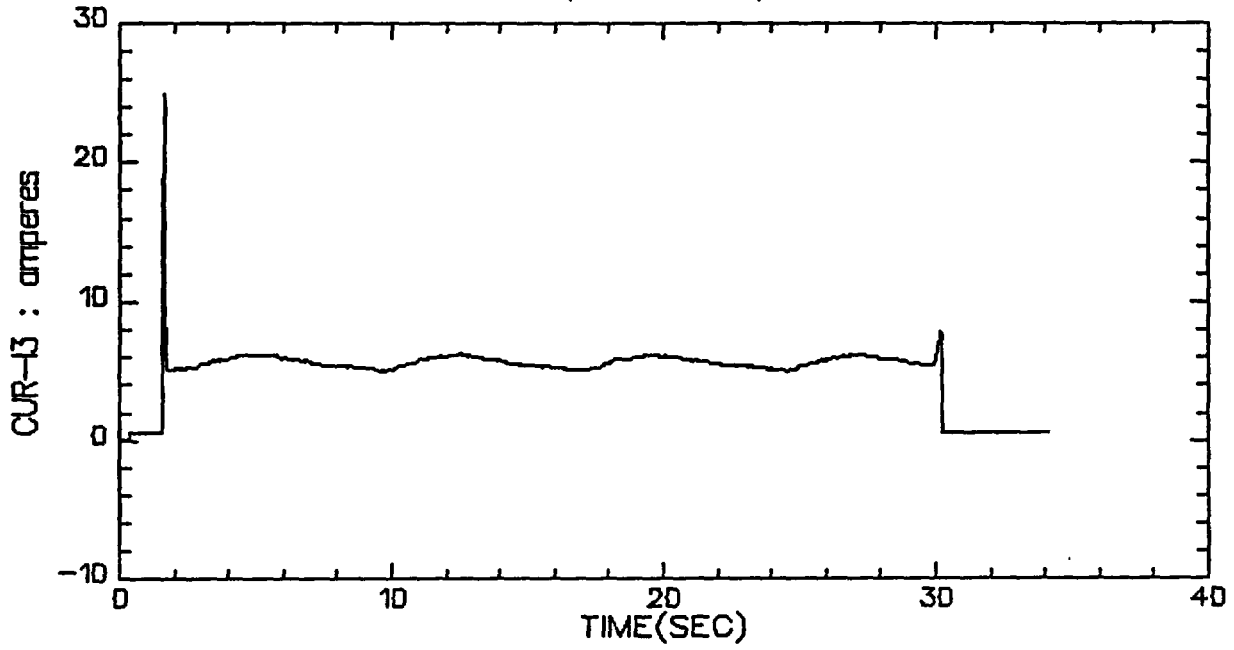

VALVE A, TEST 11, STEP 1

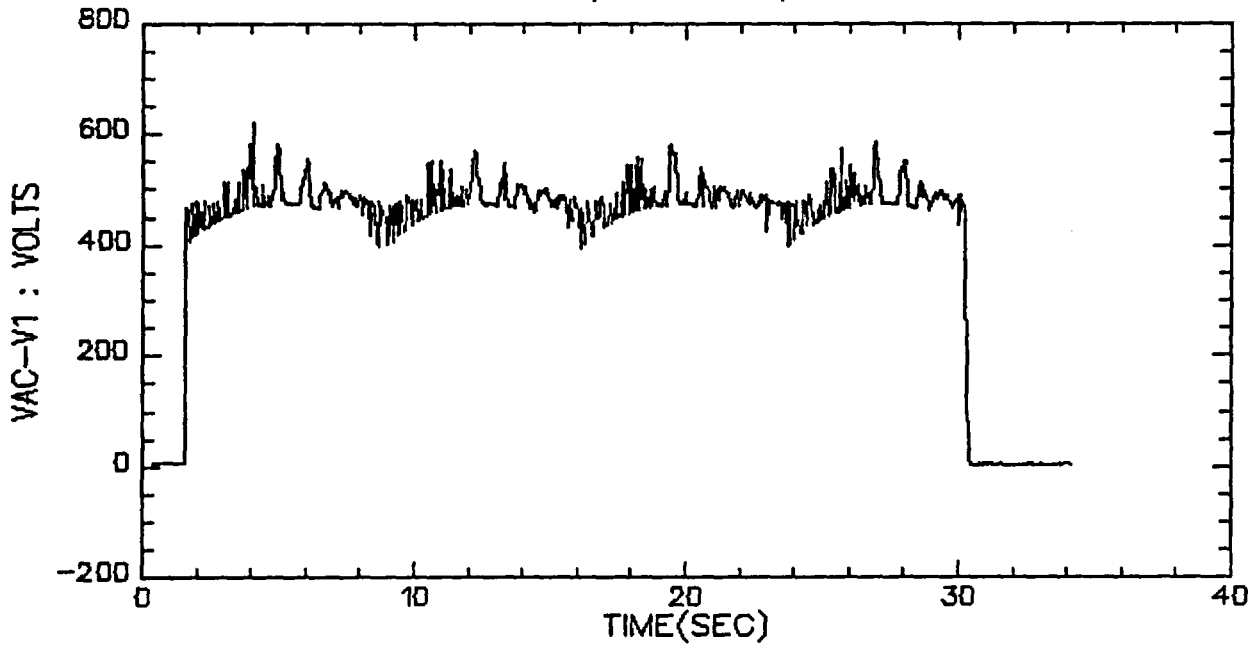

VALVE A, TEST 11, STEP 1

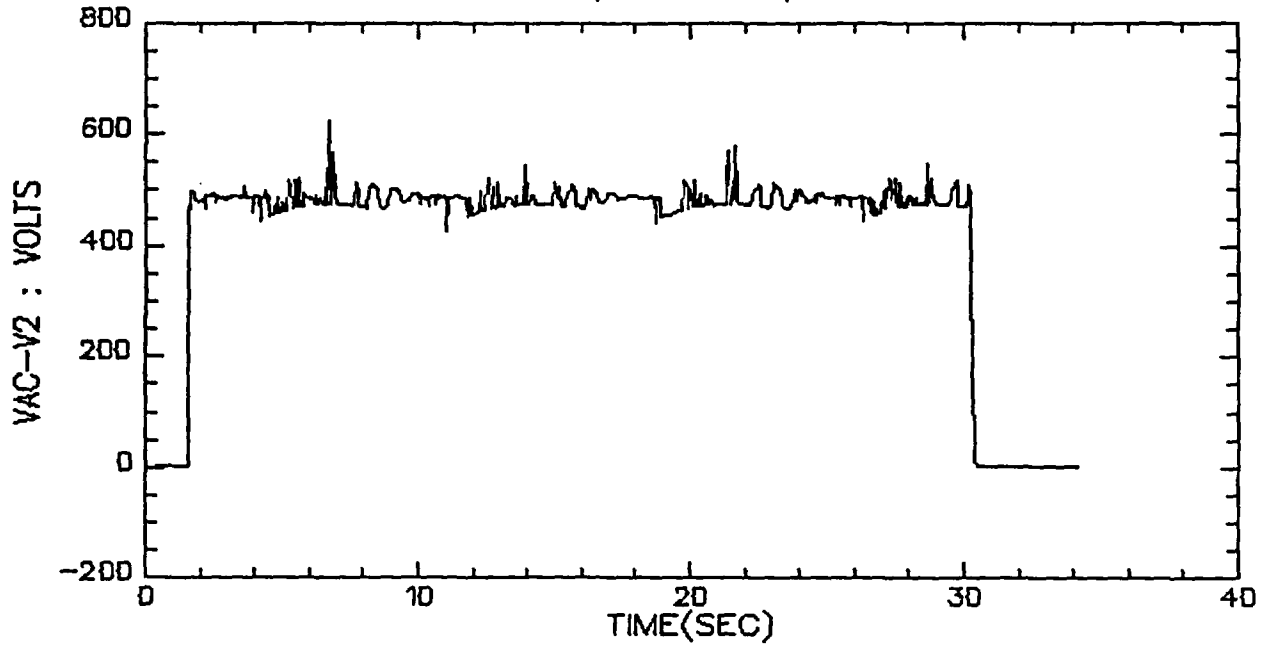

VALVE A, TEST 11, STEP 1

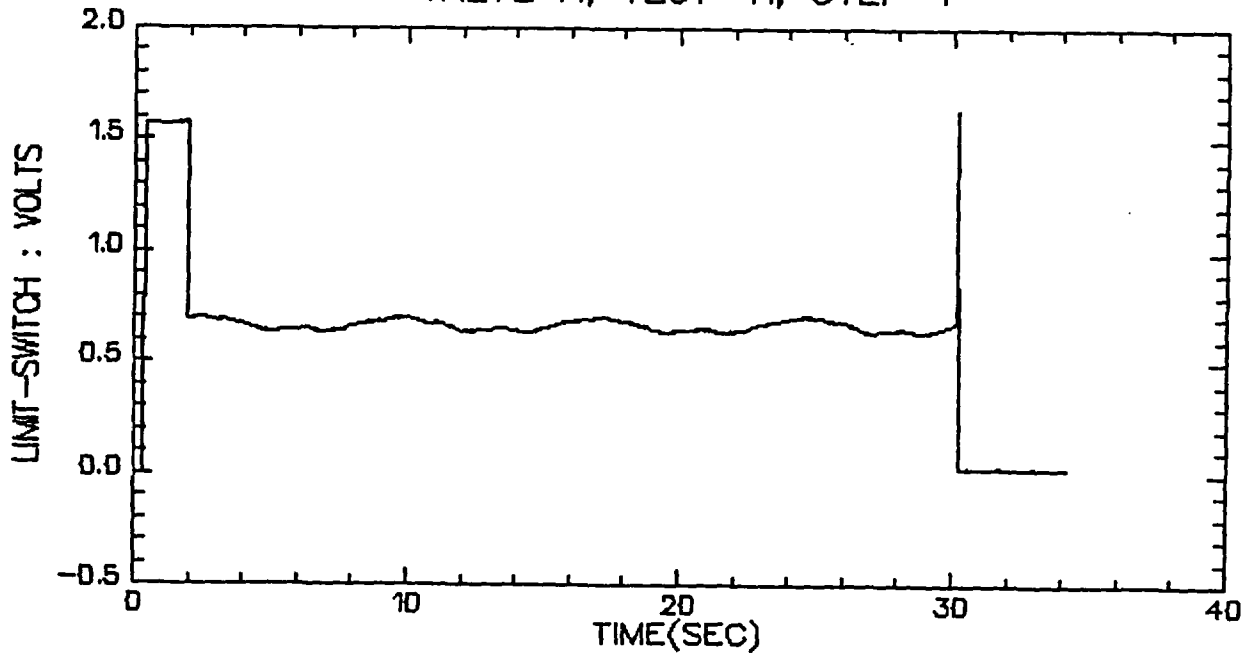

VALVE A, TEST 11, STEP 1

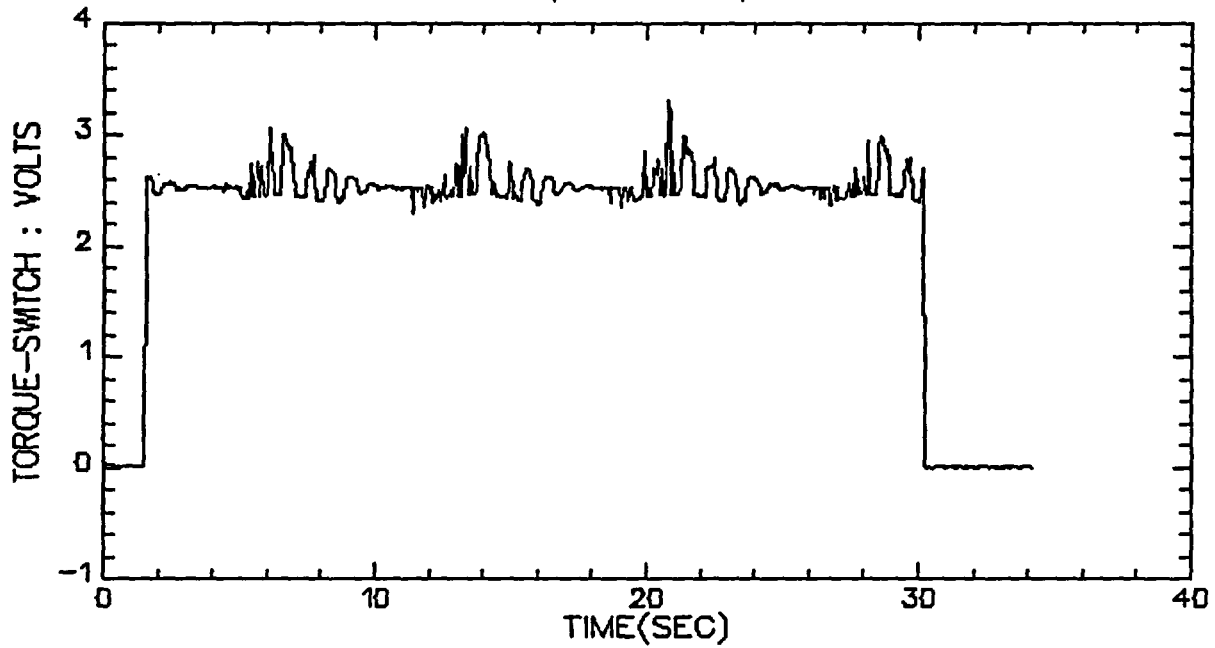

VALVE A, TEST 11, STEP 1

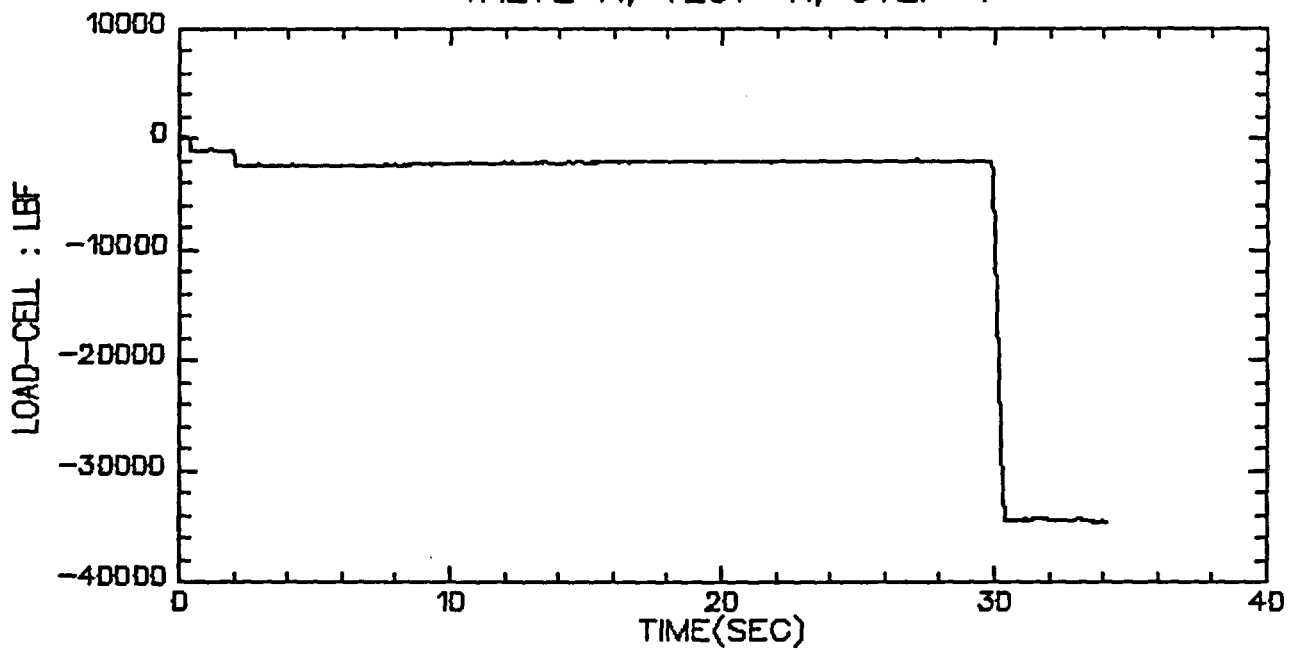

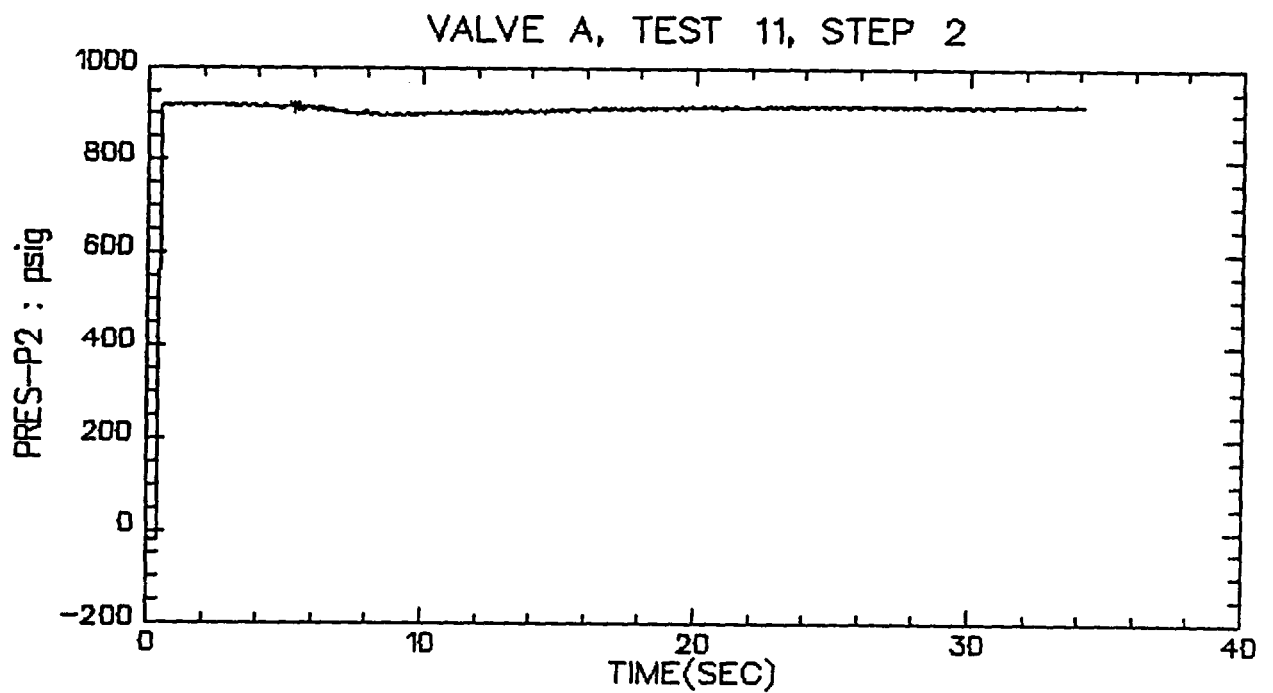
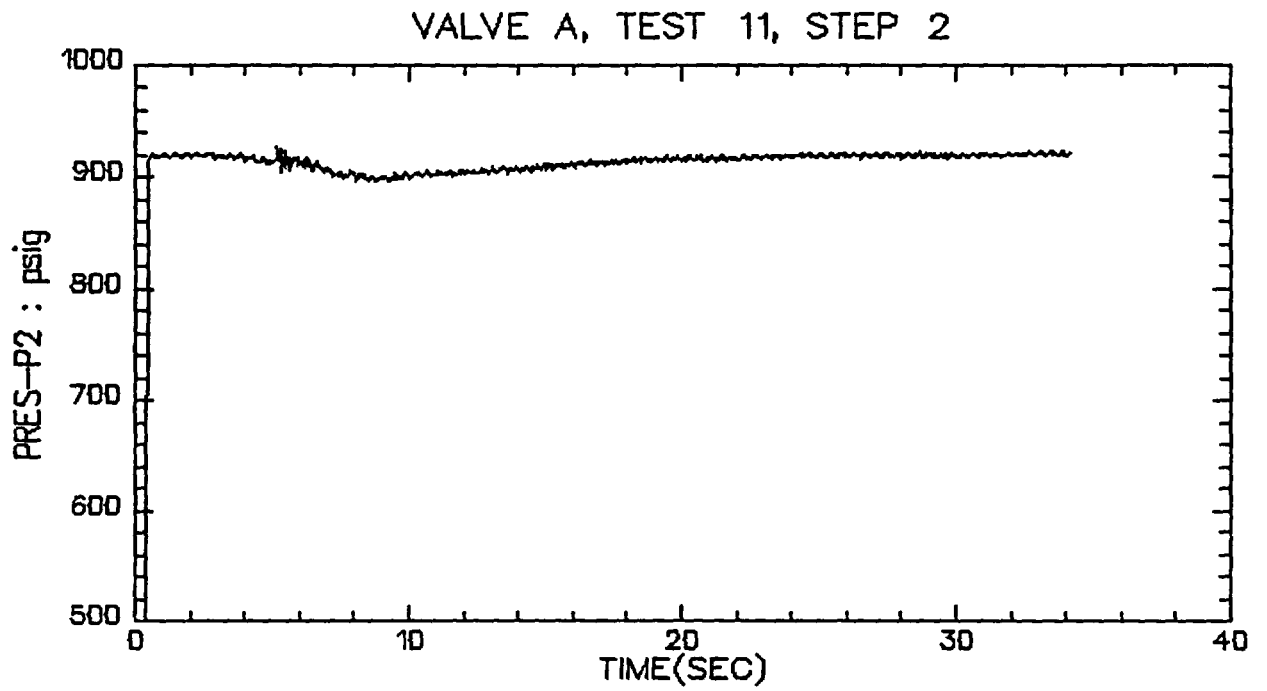

VALVE A, TEST 11, STEP 2

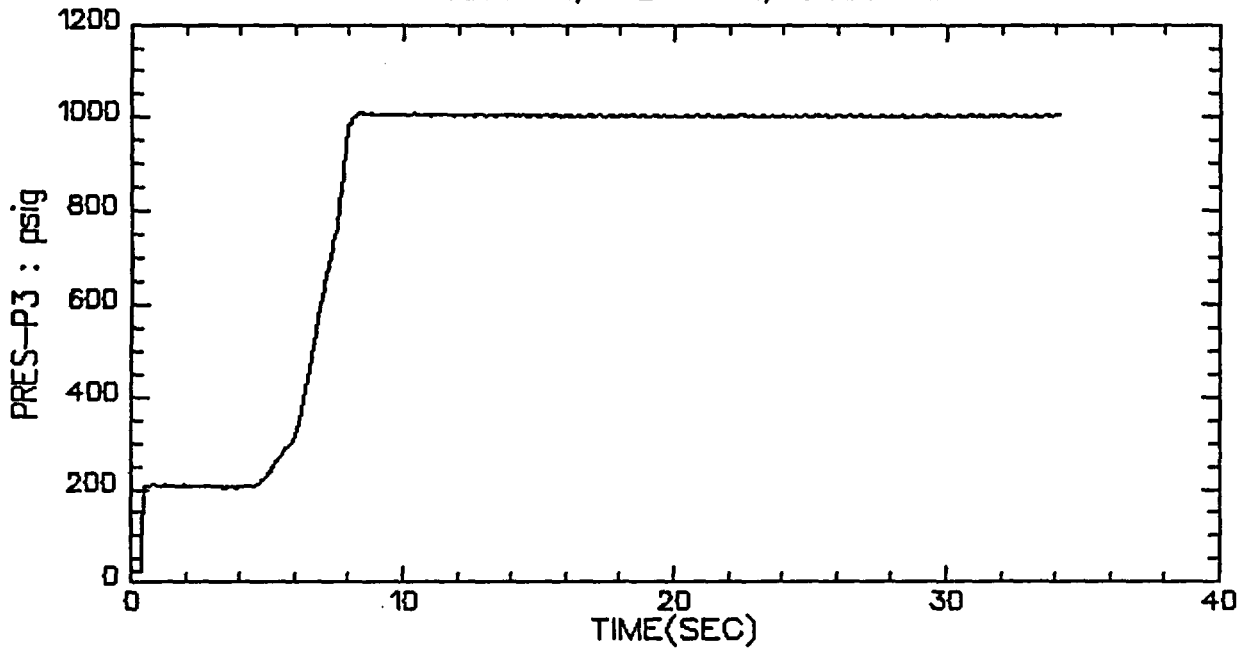

VALVE A, TEST 11, STEP 2

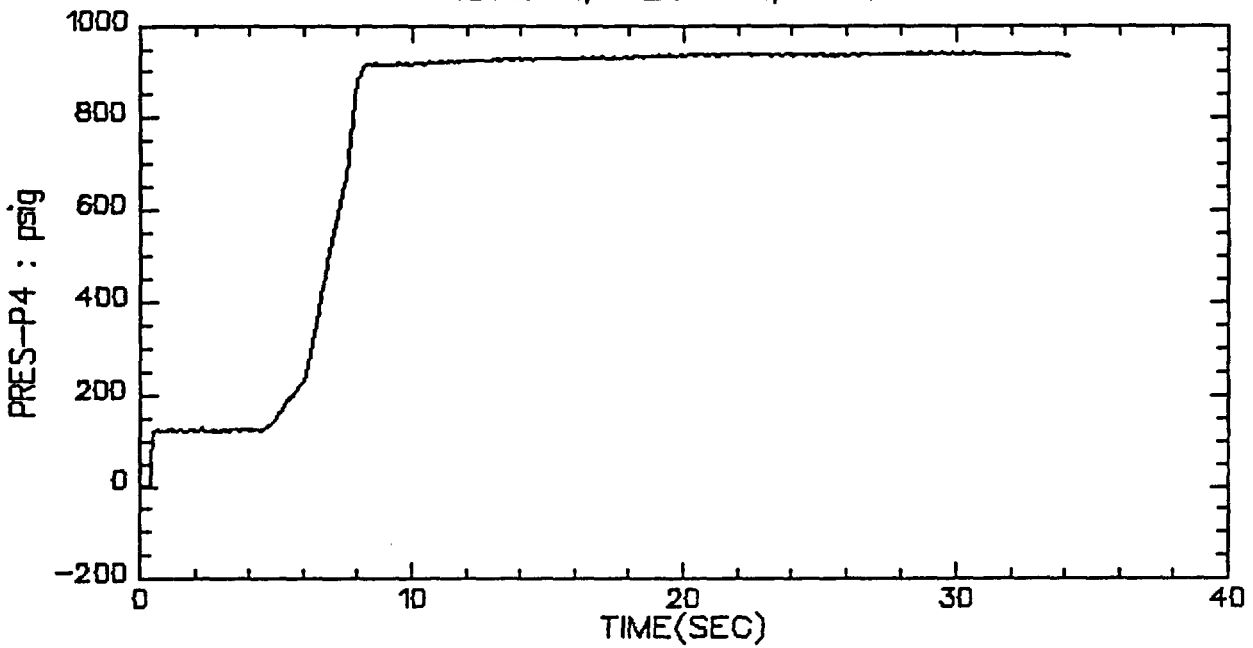

VALVE A, TEST 11, STEP 2

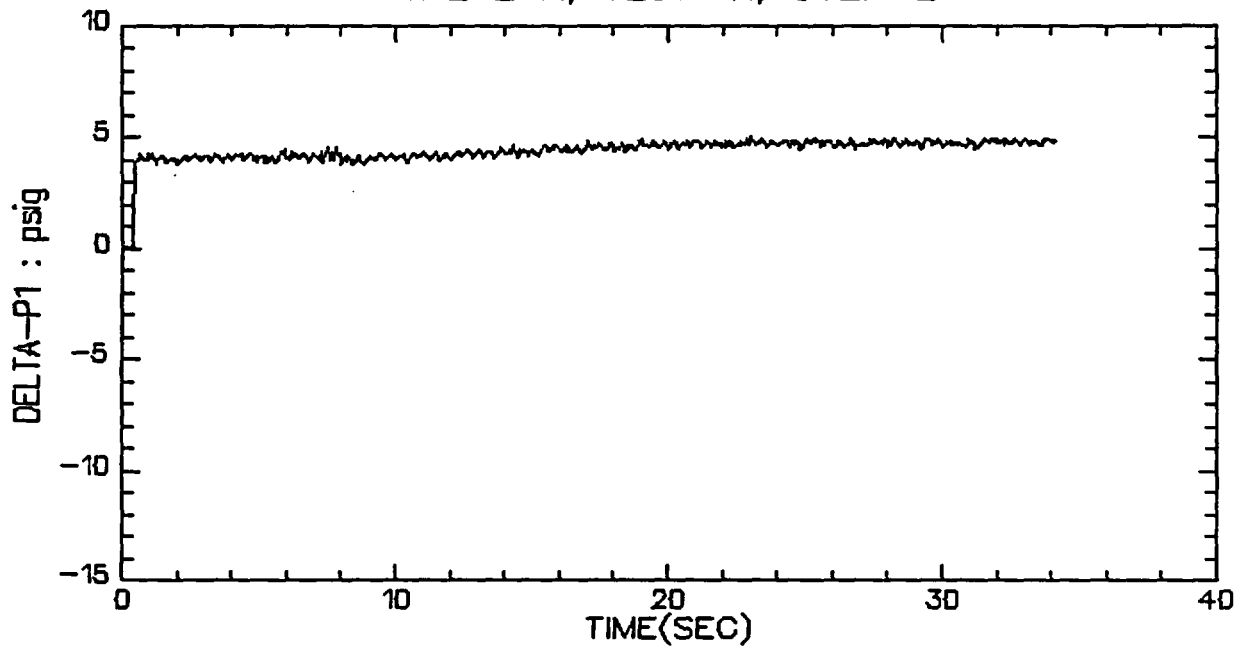

VALVE A, TEST 11, STEP 2

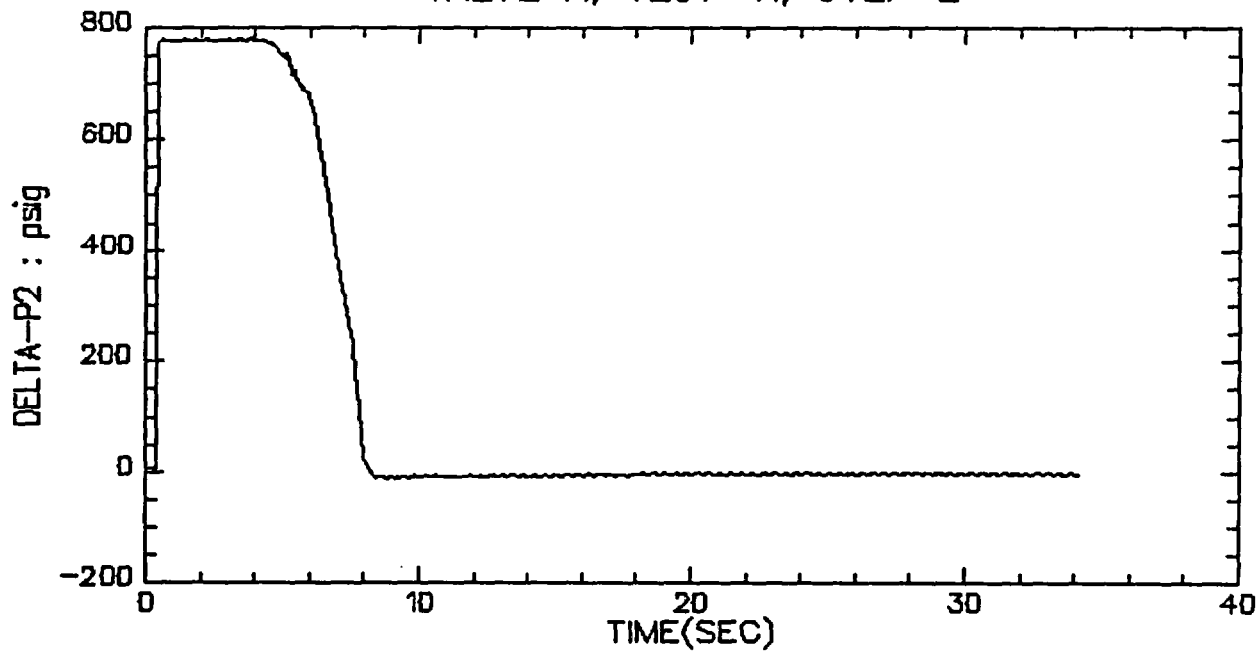

VALVE A, TEST 11, STEP 2

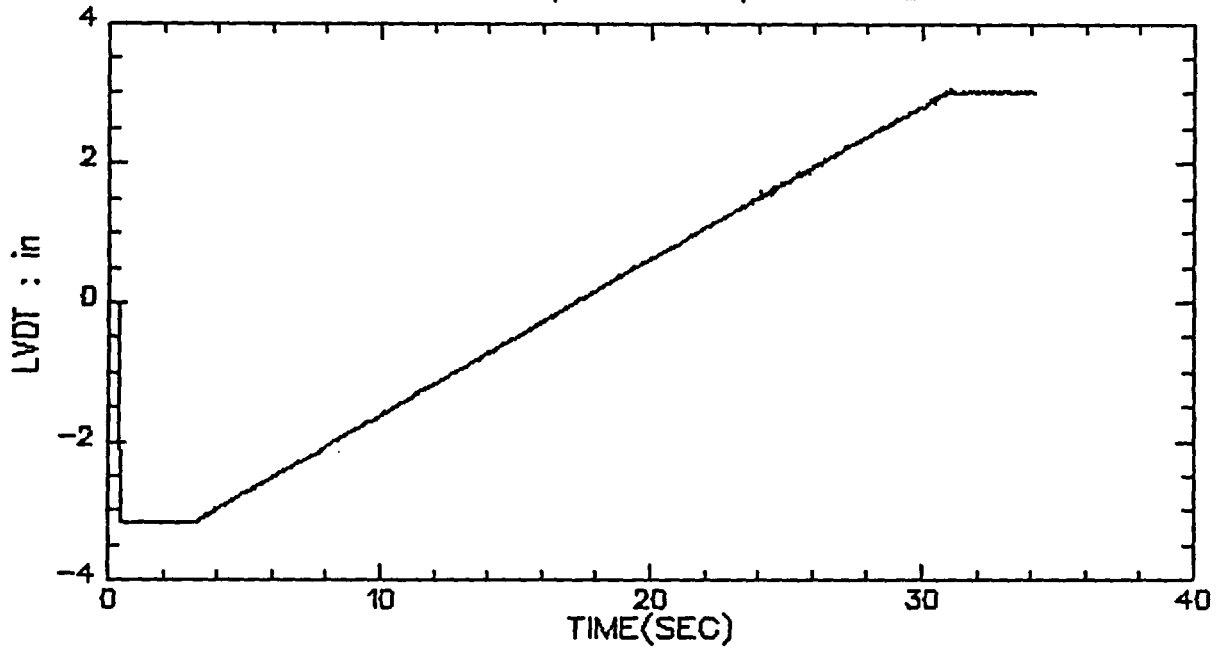

VALVE A, TEST 11, STEP 2

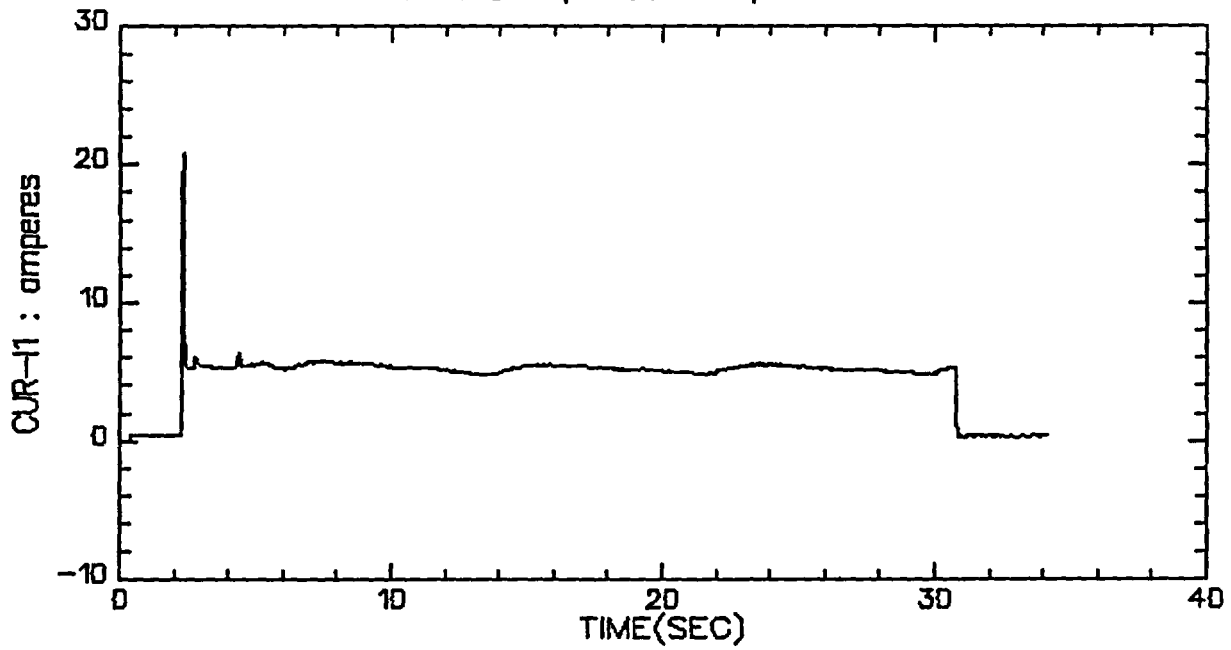

VALVE A, TEST 11, STEP 2

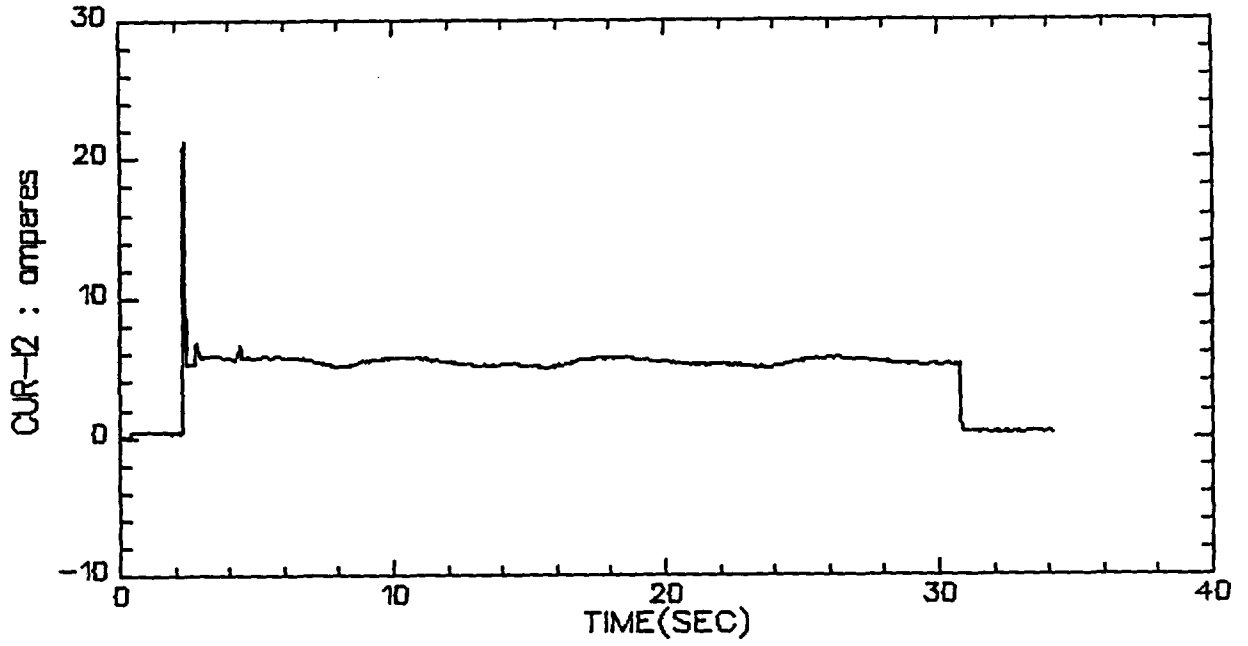

VALVE A, TEST 11, STEP 2

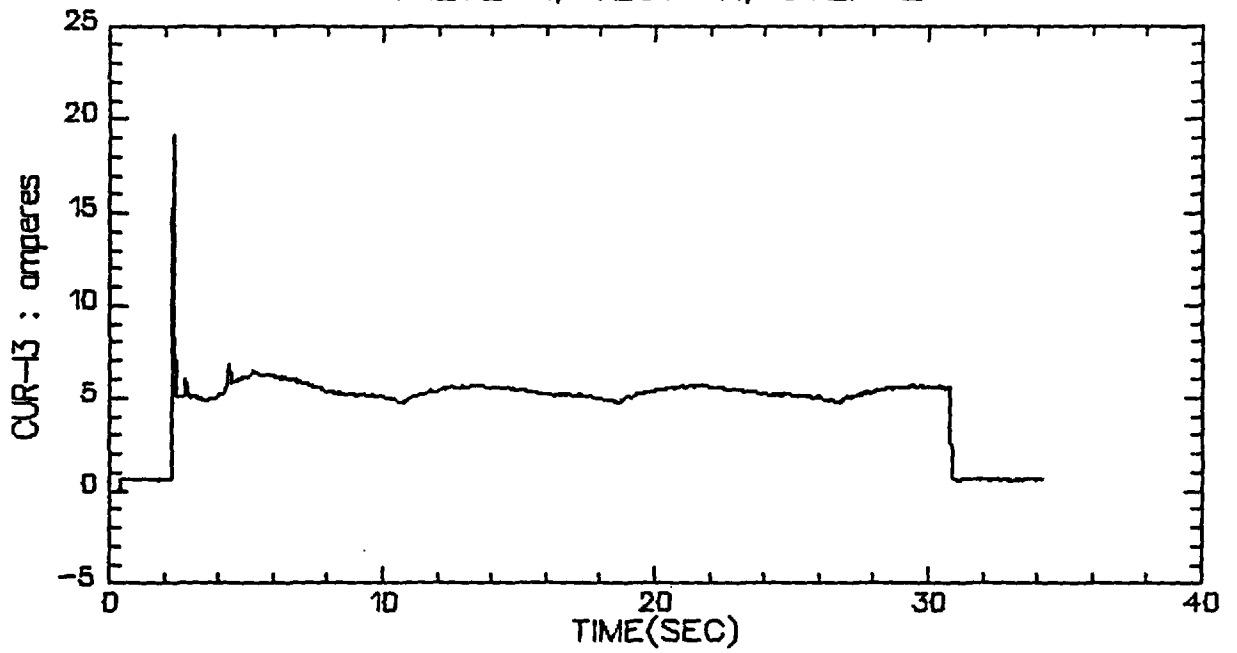

VALVE A, TEST 11, STEP 2

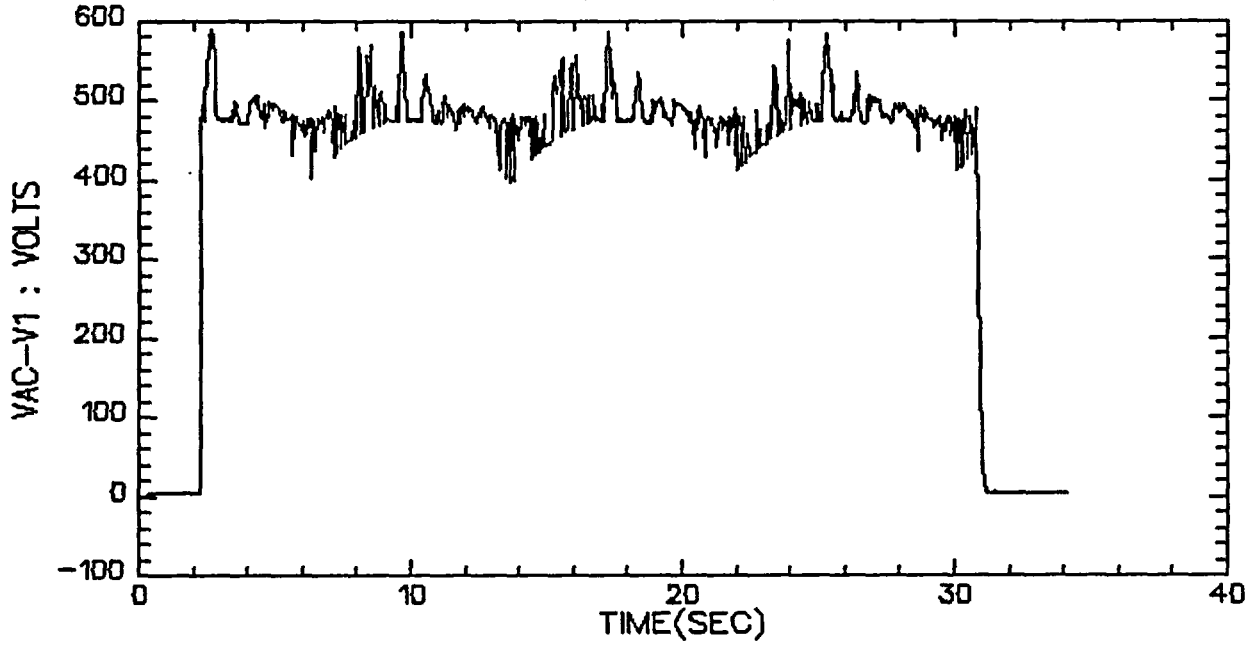

VALVE A, TEST 11, STEP 2

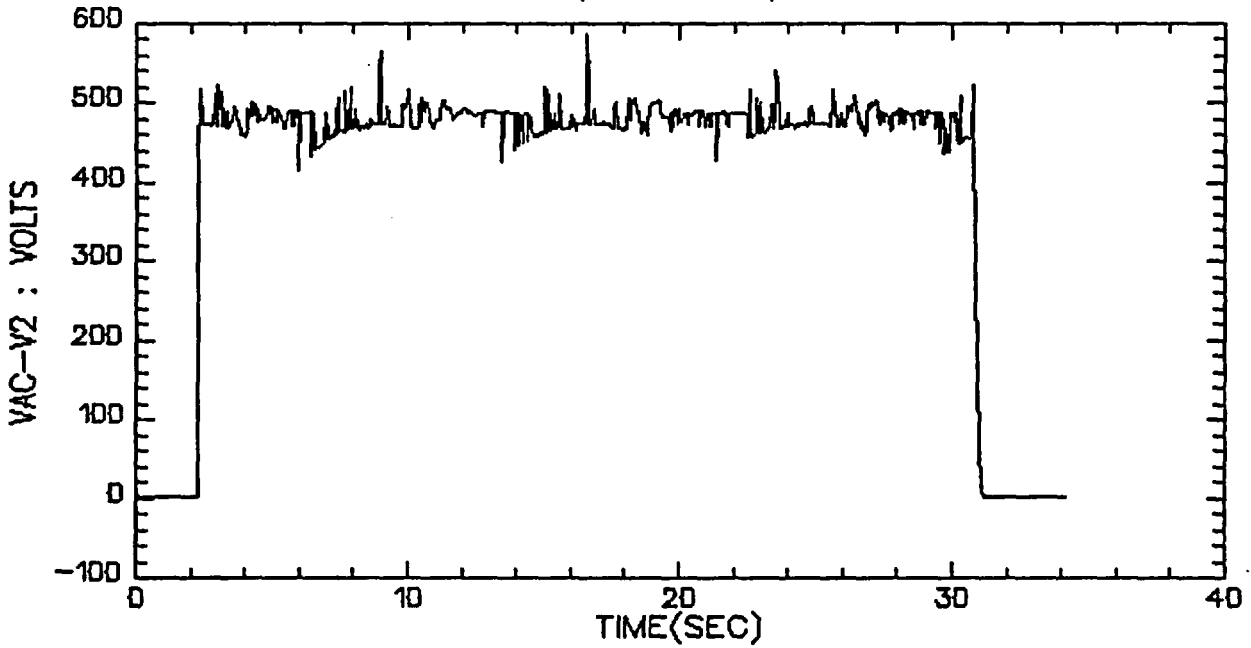

VALVE A, TEST 11, STEP 2

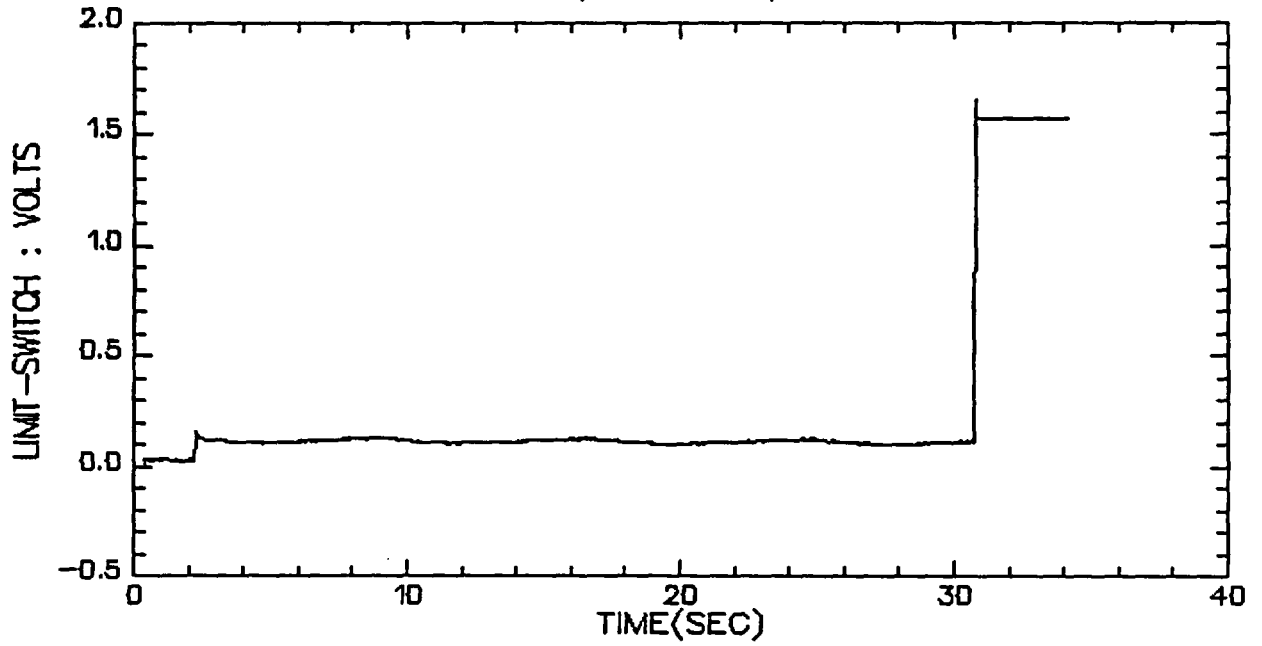

VALVE A, TEST 11, STEP 2

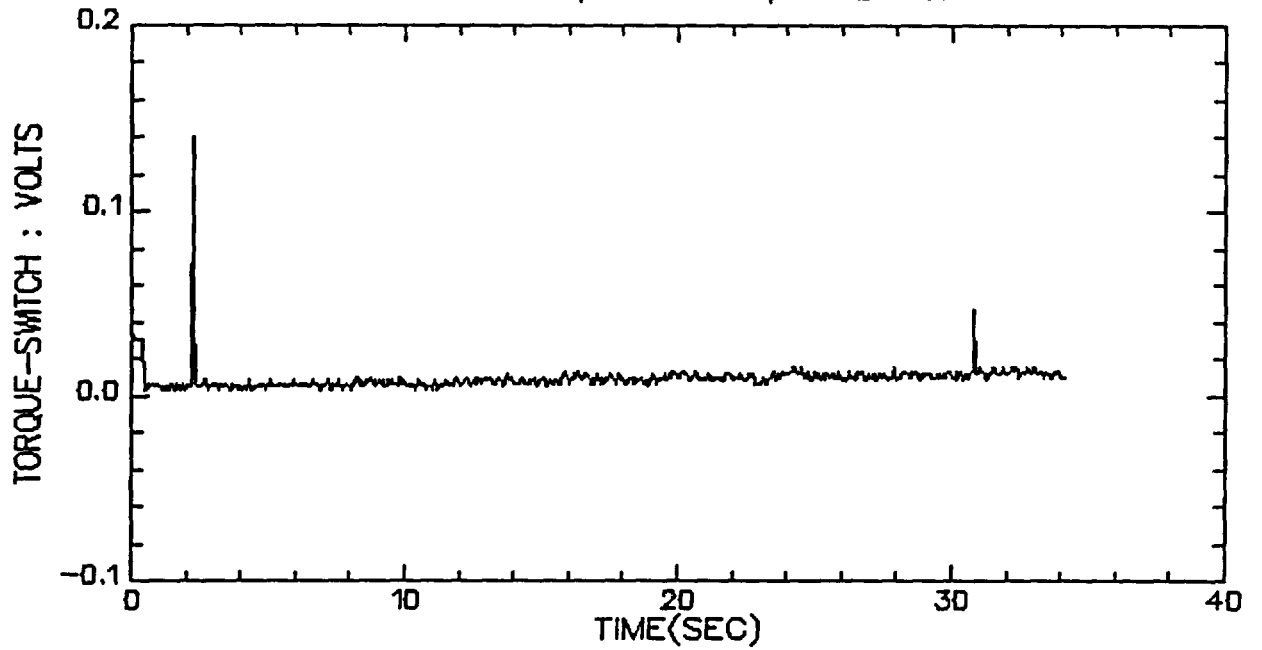

VALVE A, TEST 11, STEP 2

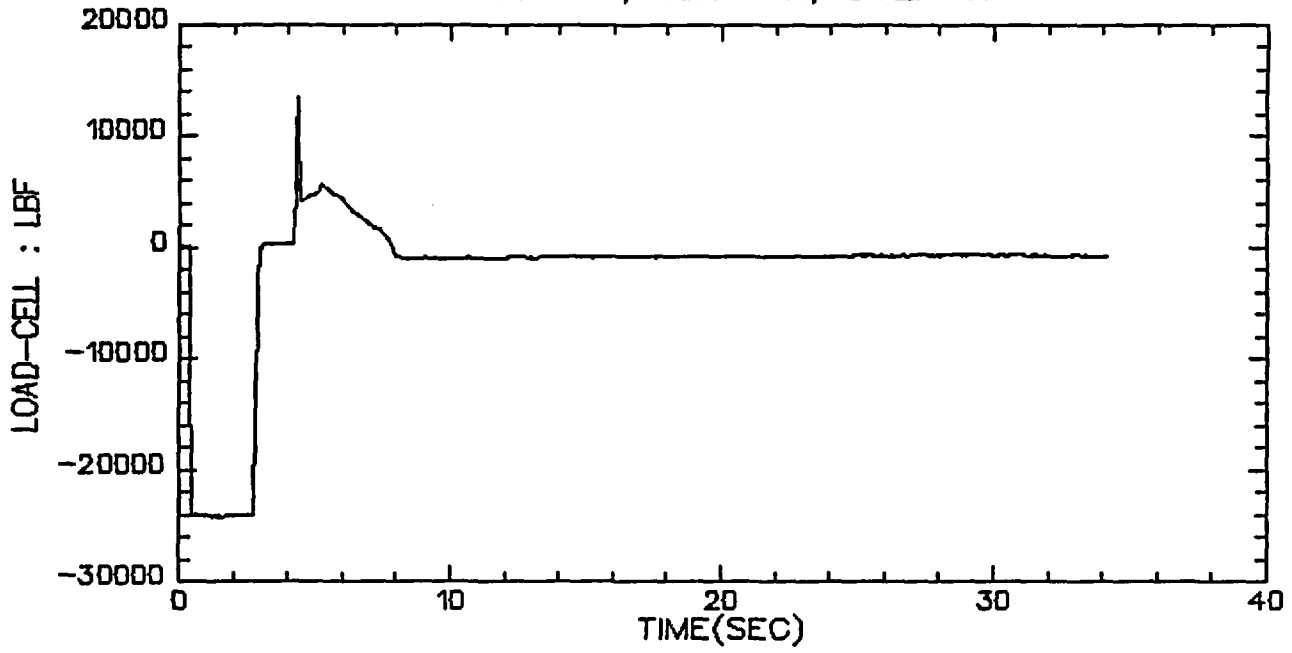

VALVE A, TEST 11, STEP 3&4

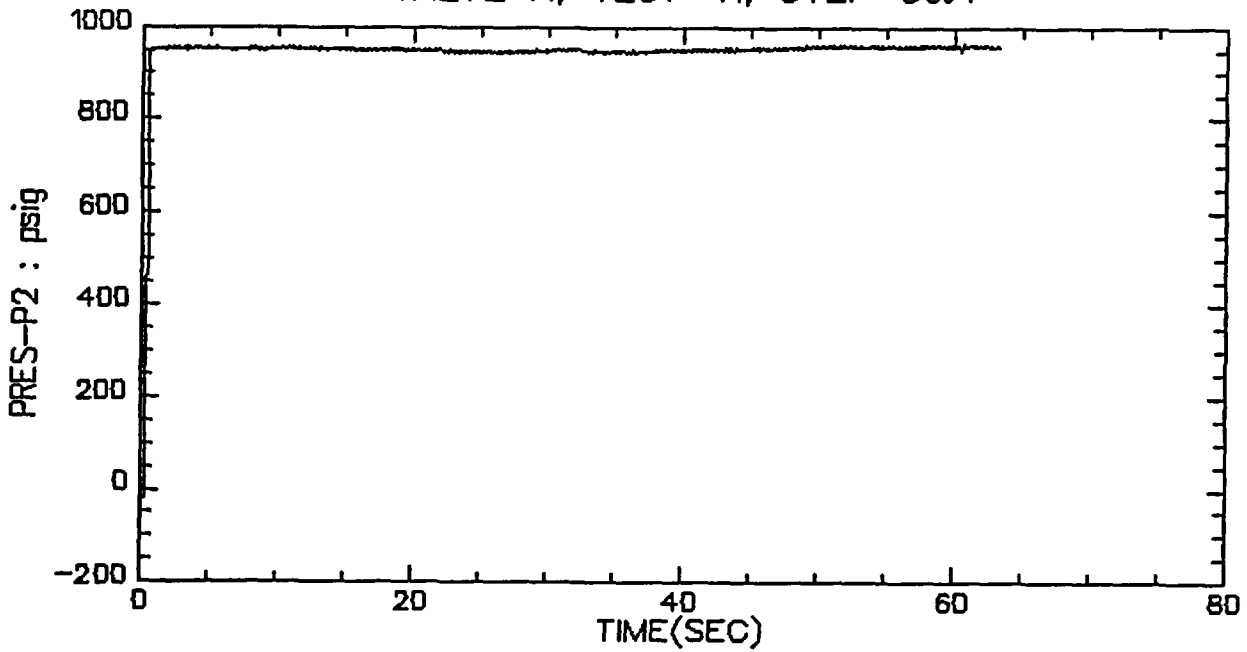

VALVE A, TEST 11, STEP 3&4

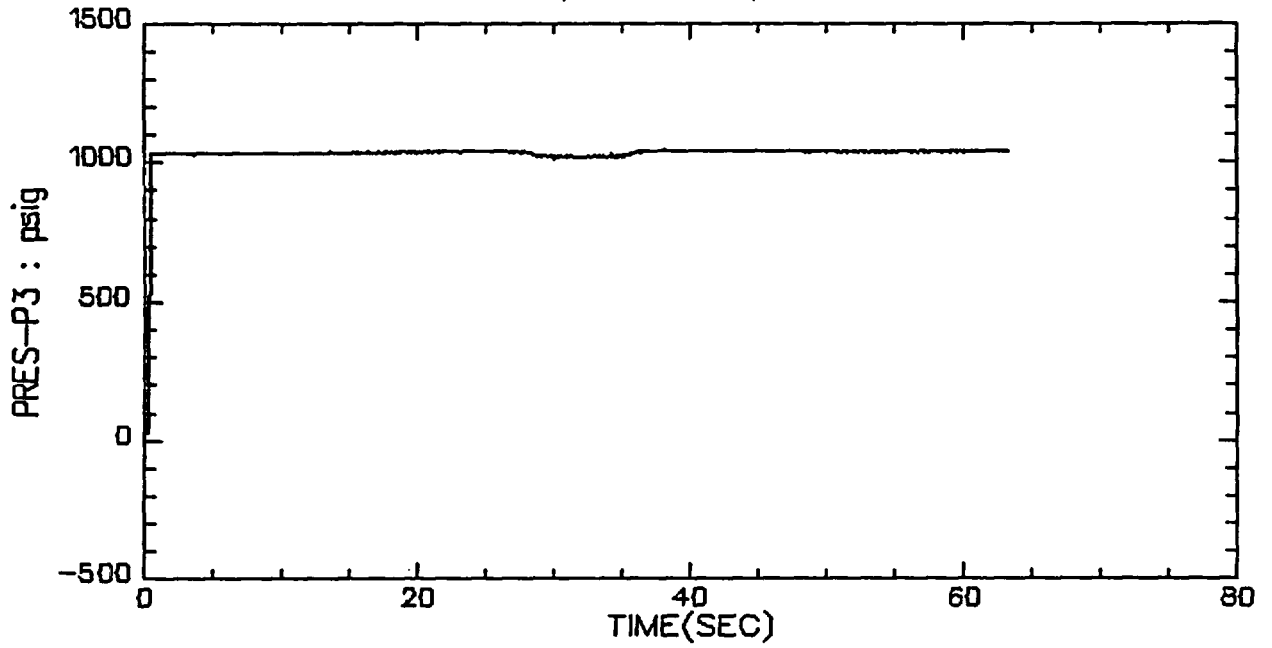

VALVE A, TEST 11, STEP 3&4

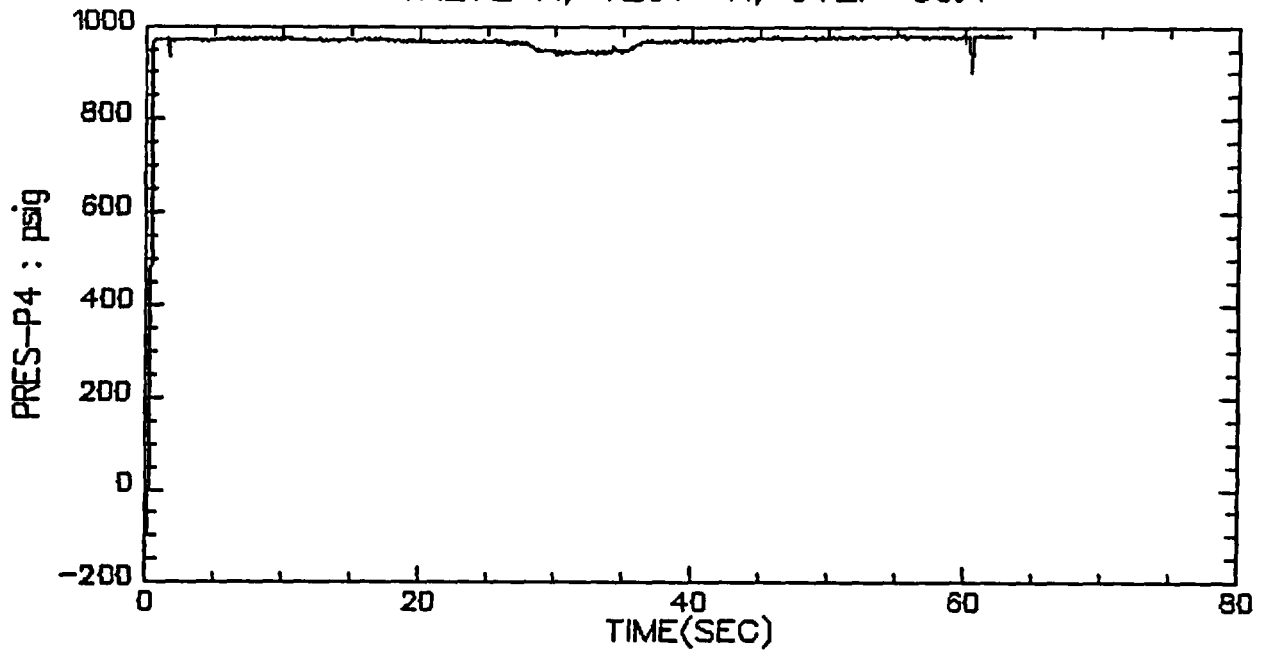

VALVE A, TEST 11, STEP 3&4

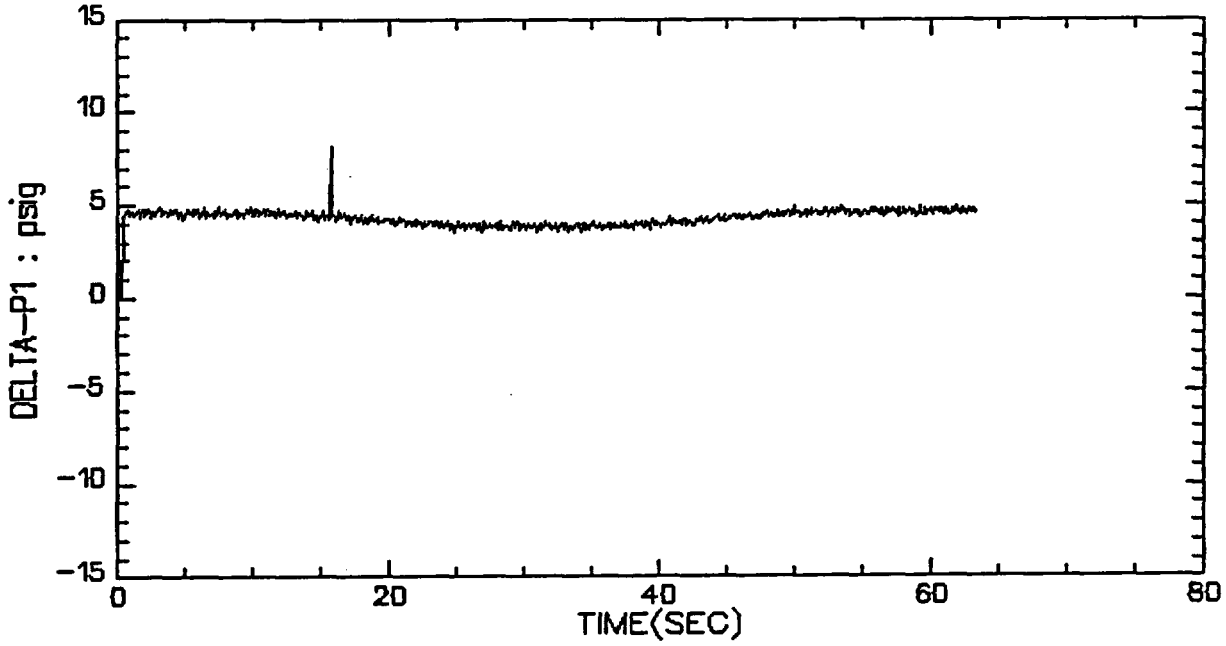

VALVE A, TEST 11, STEP 3&4

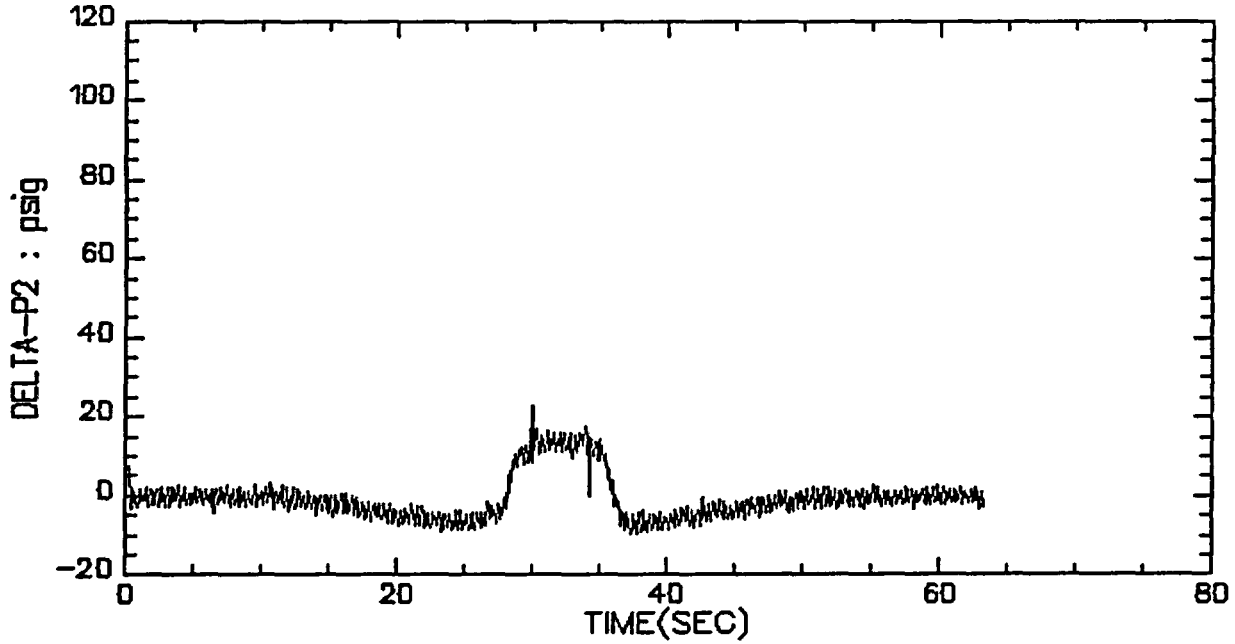

VALVE A, TEST 11, STEP 3&4

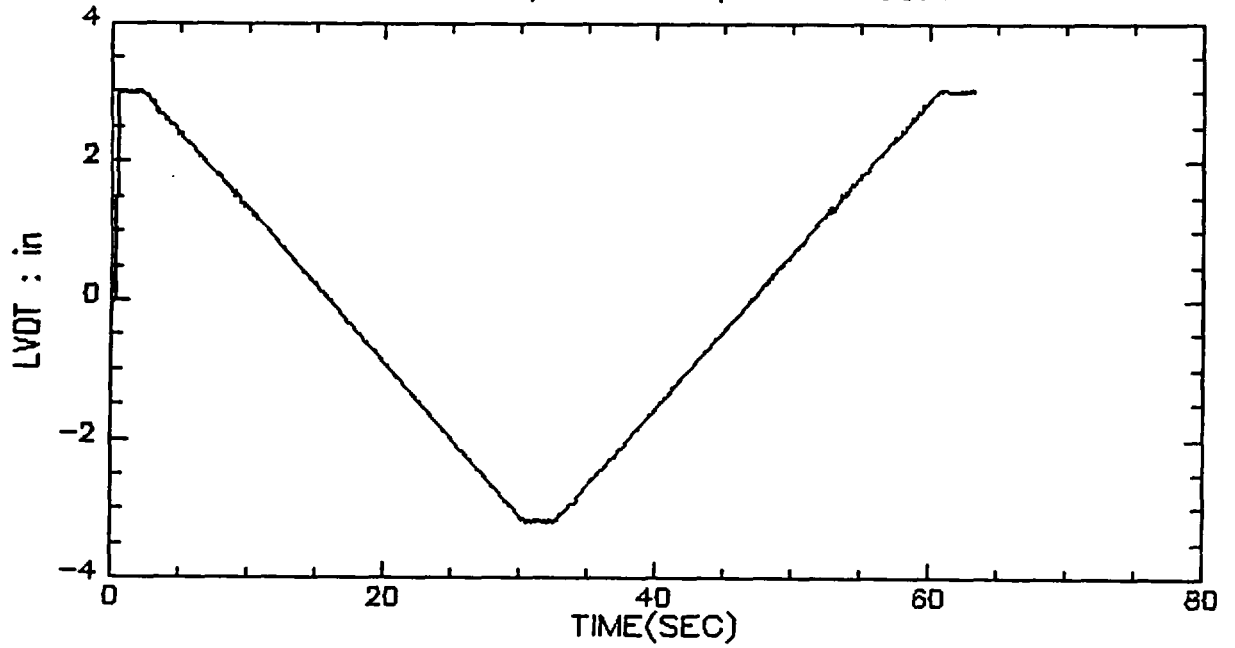

VALVE A, TEST 11, STEP 3&4

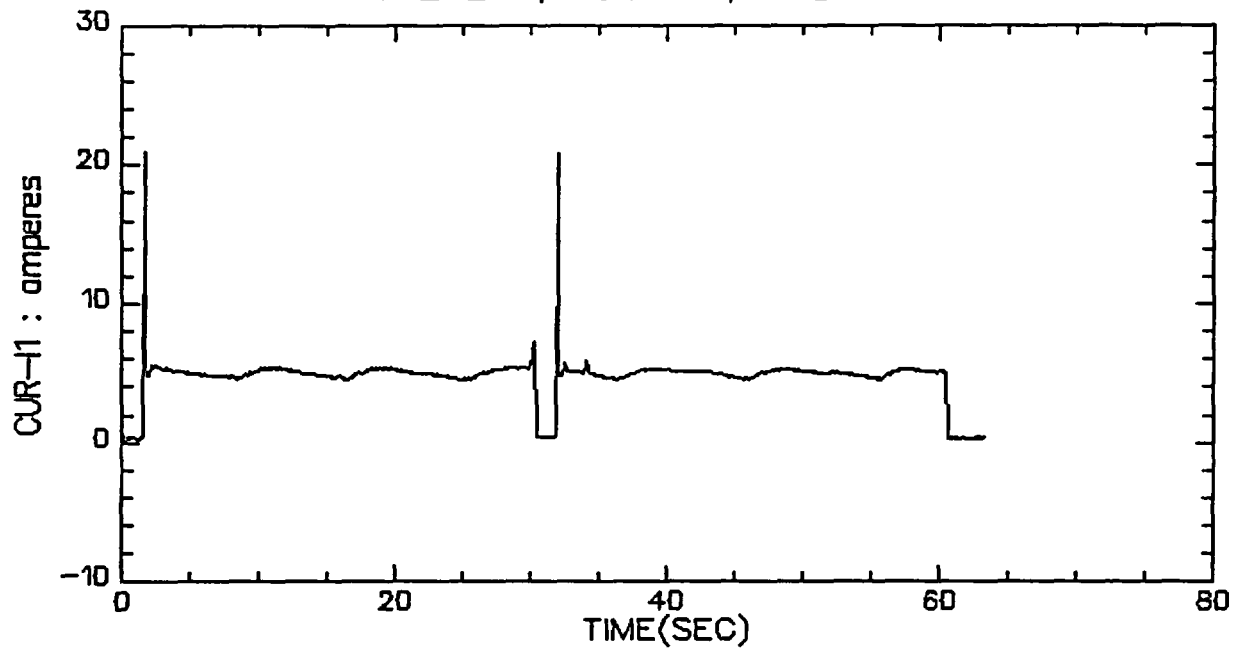

VALVE A, TEST 11, STEP 3&4

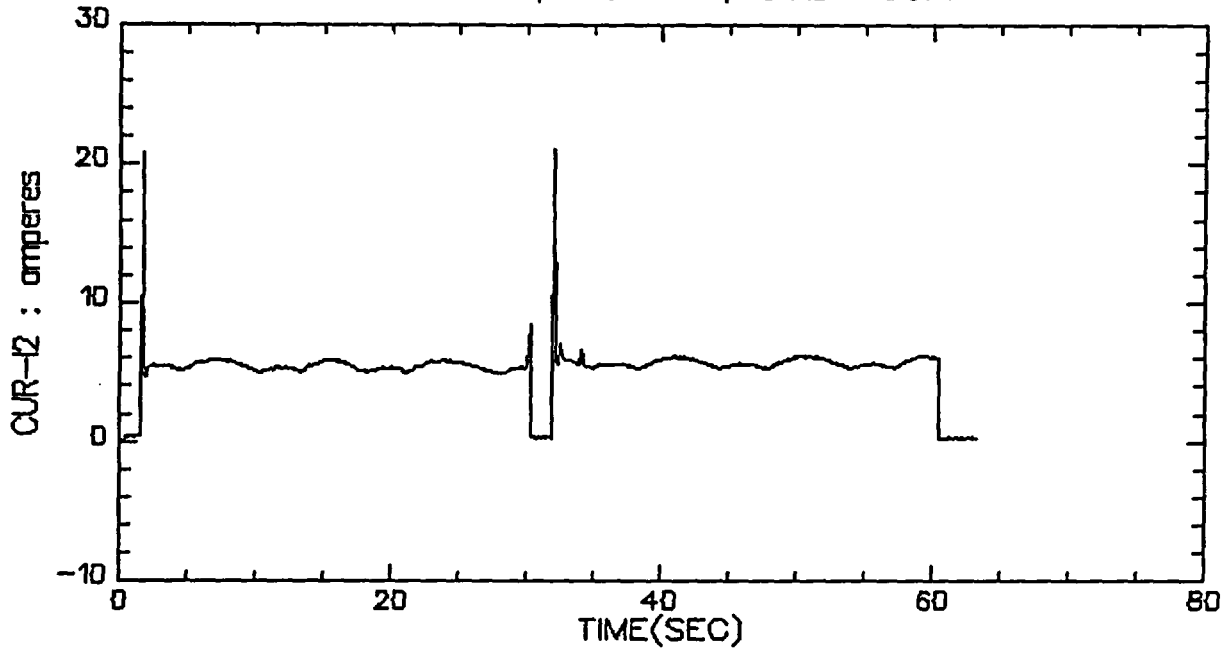

VALVE A, TEST 11, STEP 3&4

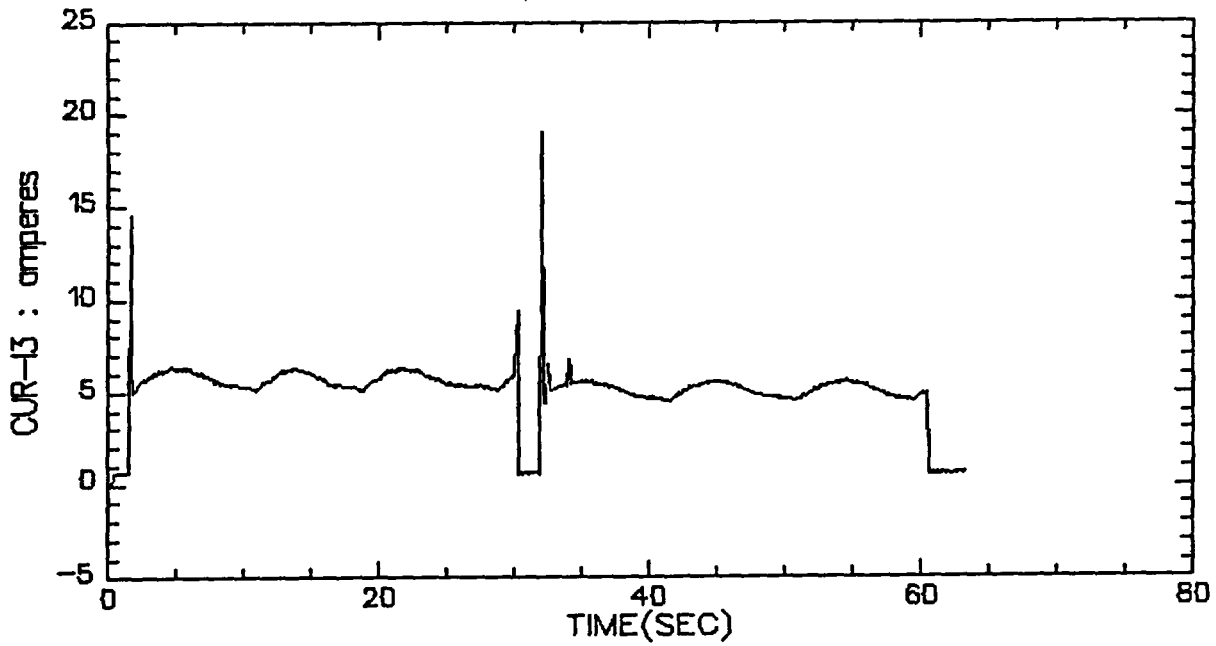

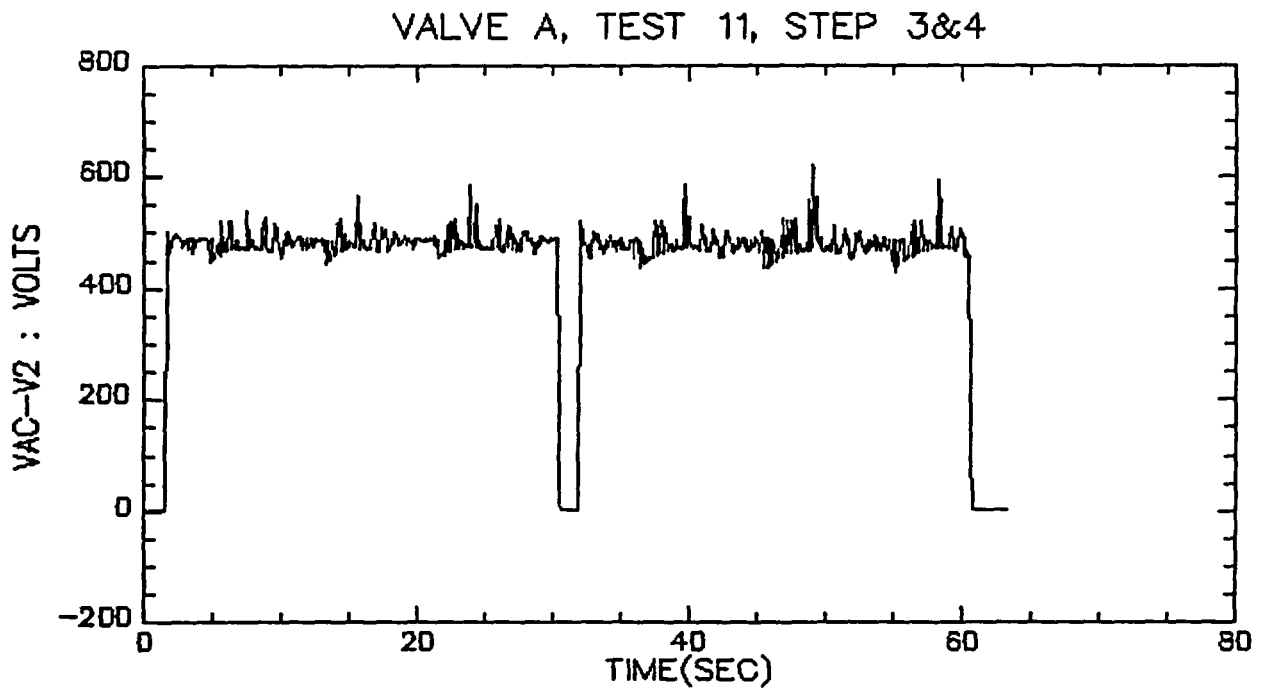
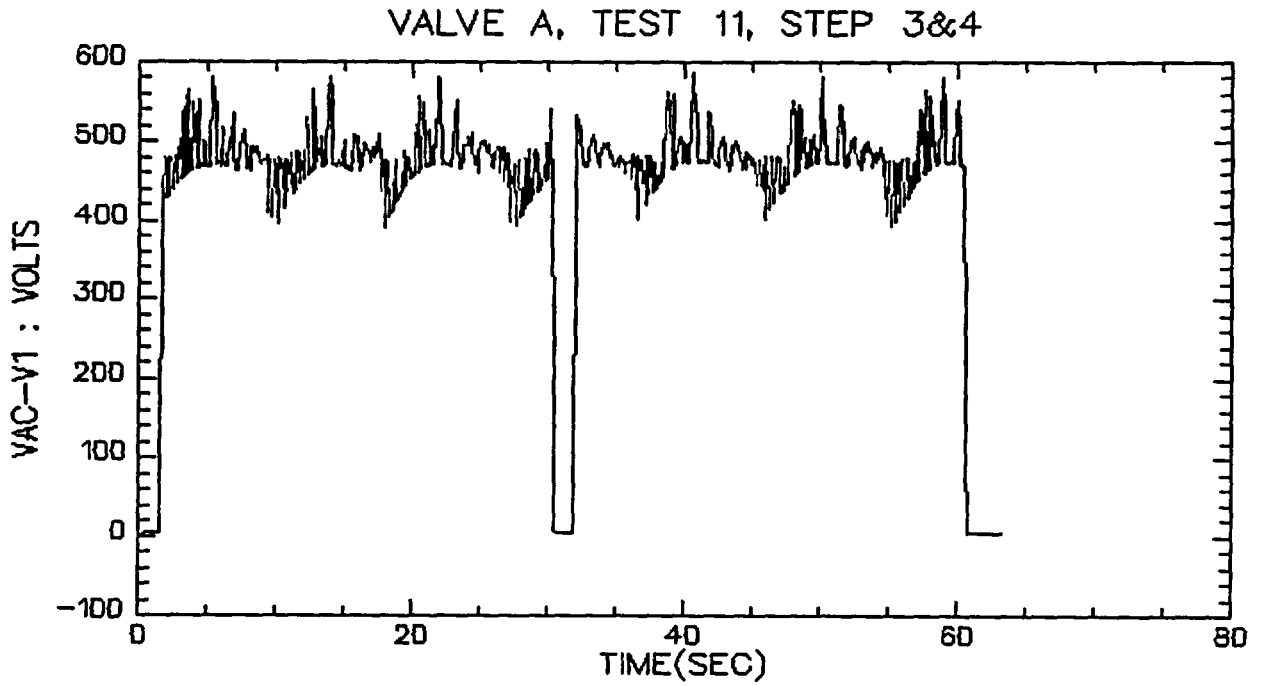

VALVE A, TEST 11, STEP 3&4

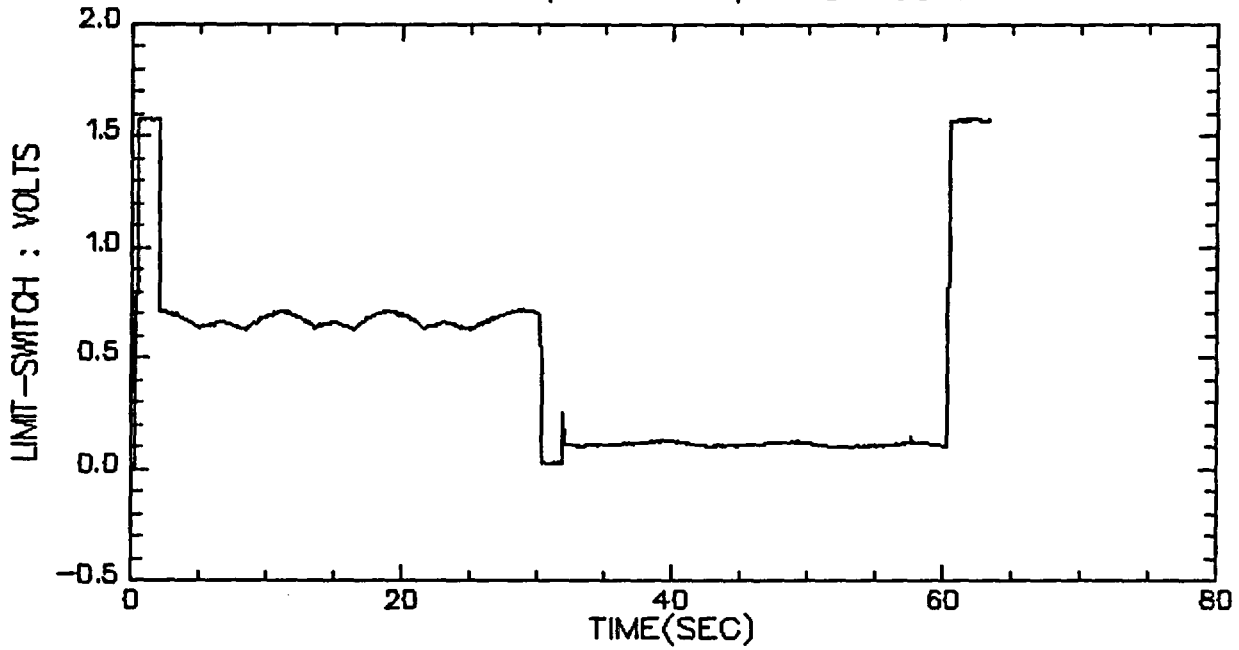

VALVE A, TEST 11, STEP 3&4

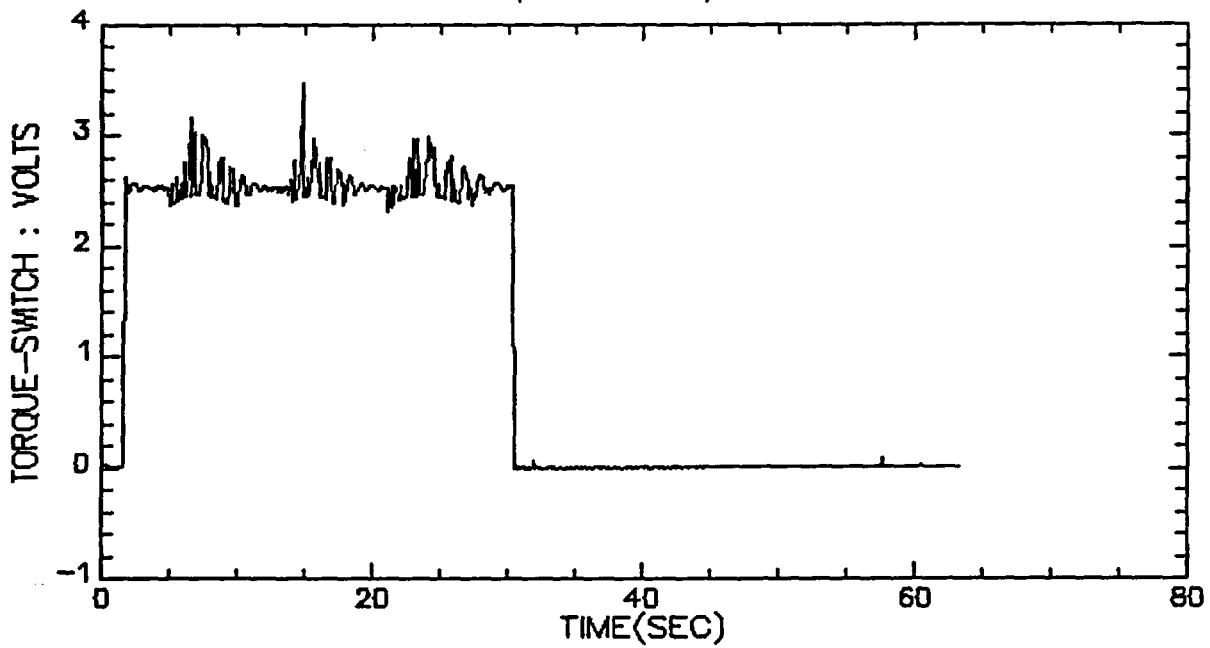

VALVE A, TEST 11, STEP 3&4

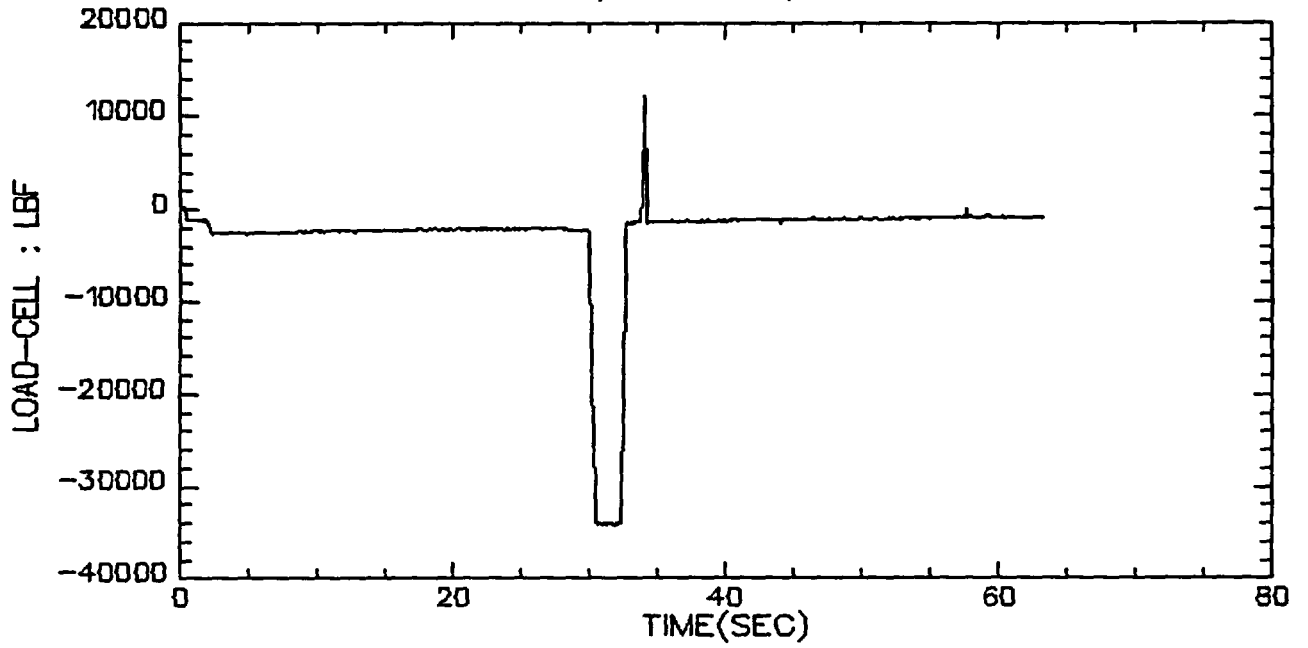

VALVE A, TEST 11, STEP 5

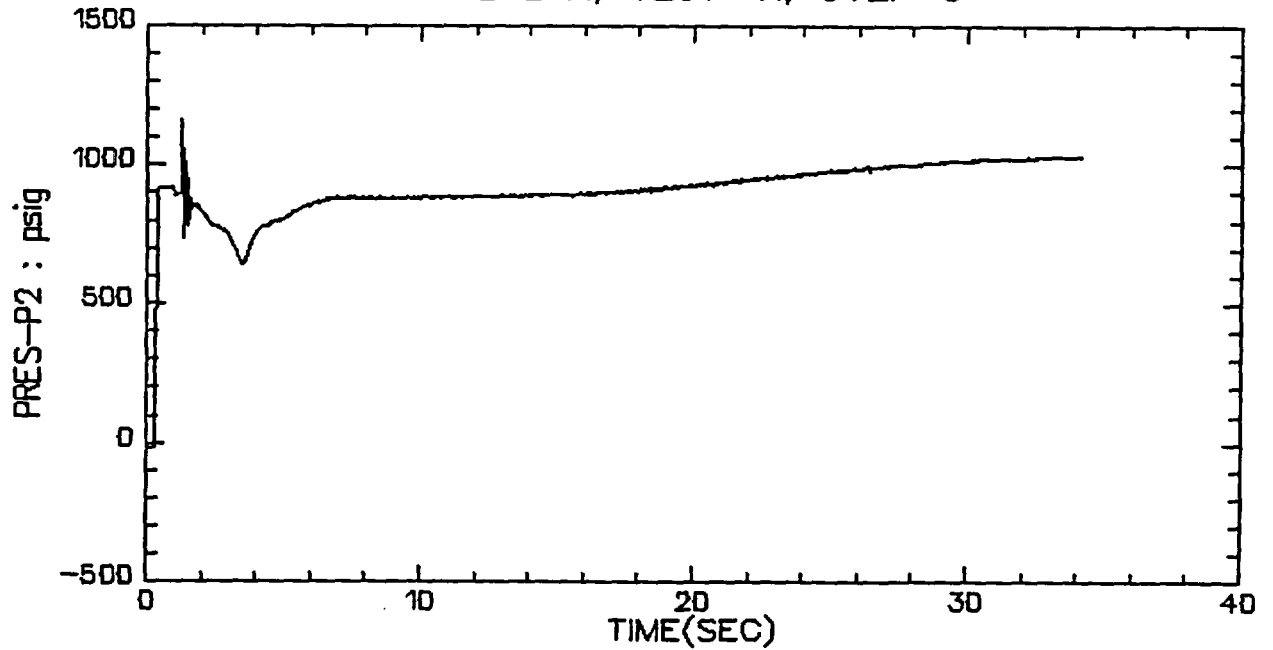

VALVE A, TEST 11, STEP 5

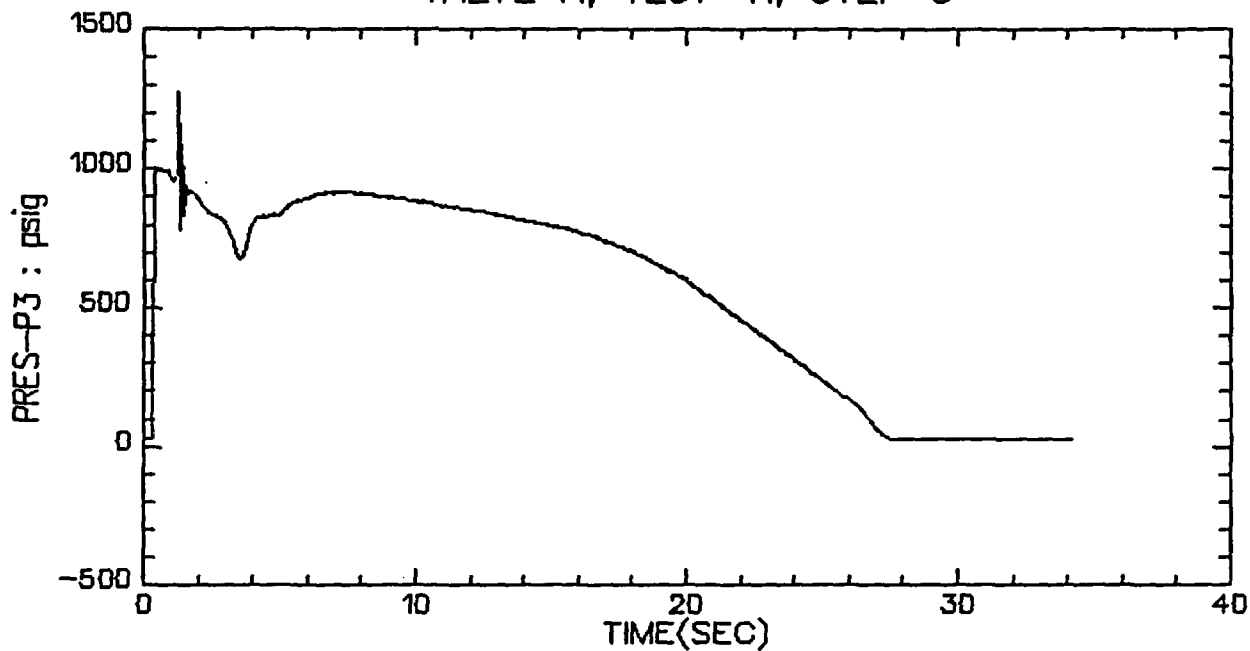

VALVE A, TEST 11, STEP 5

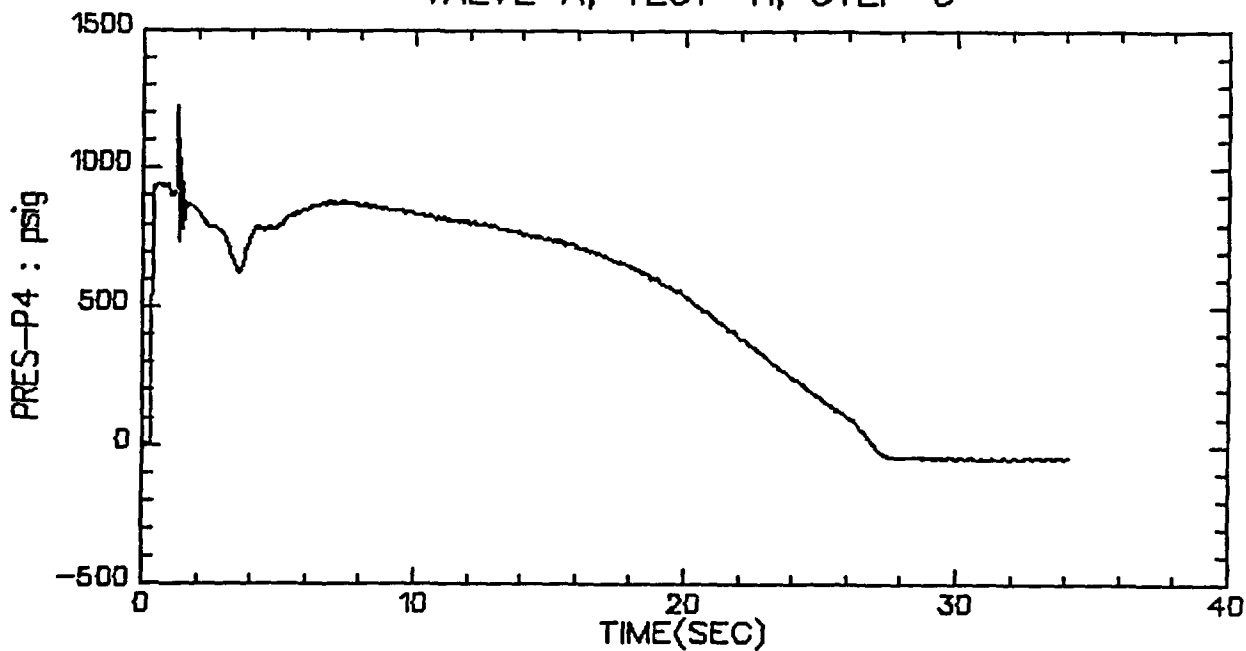

VALVE A, TEST 11, STEP 5

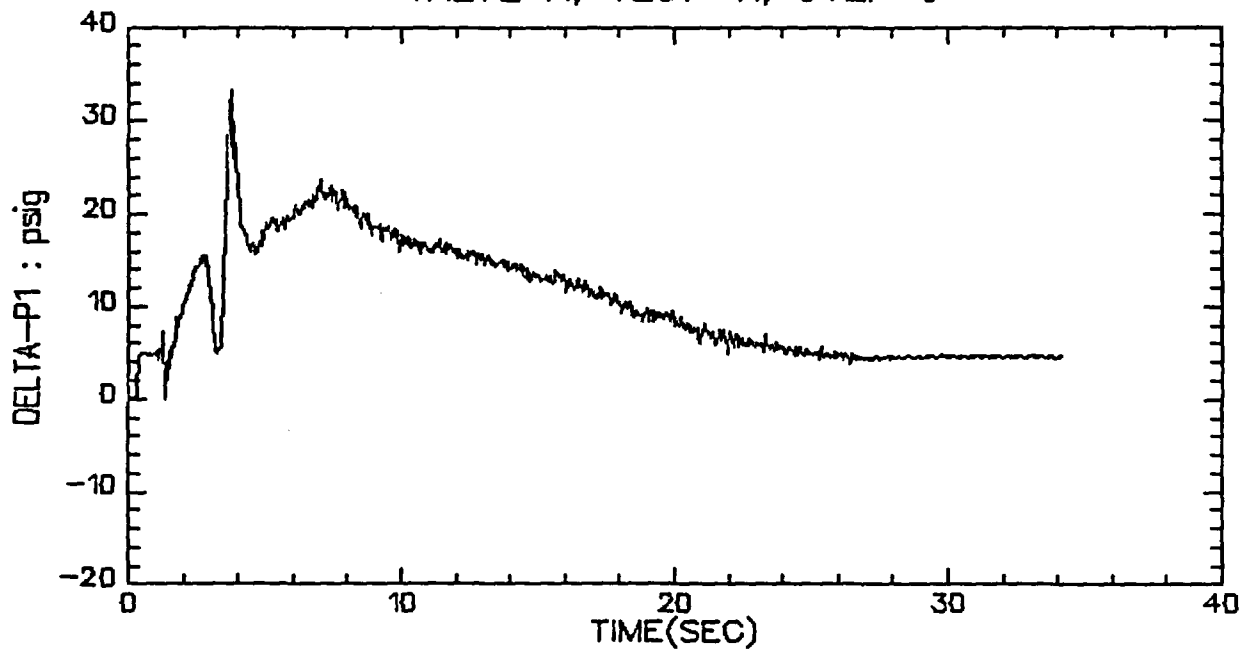

VALVE A, TEST 11, STEP 5

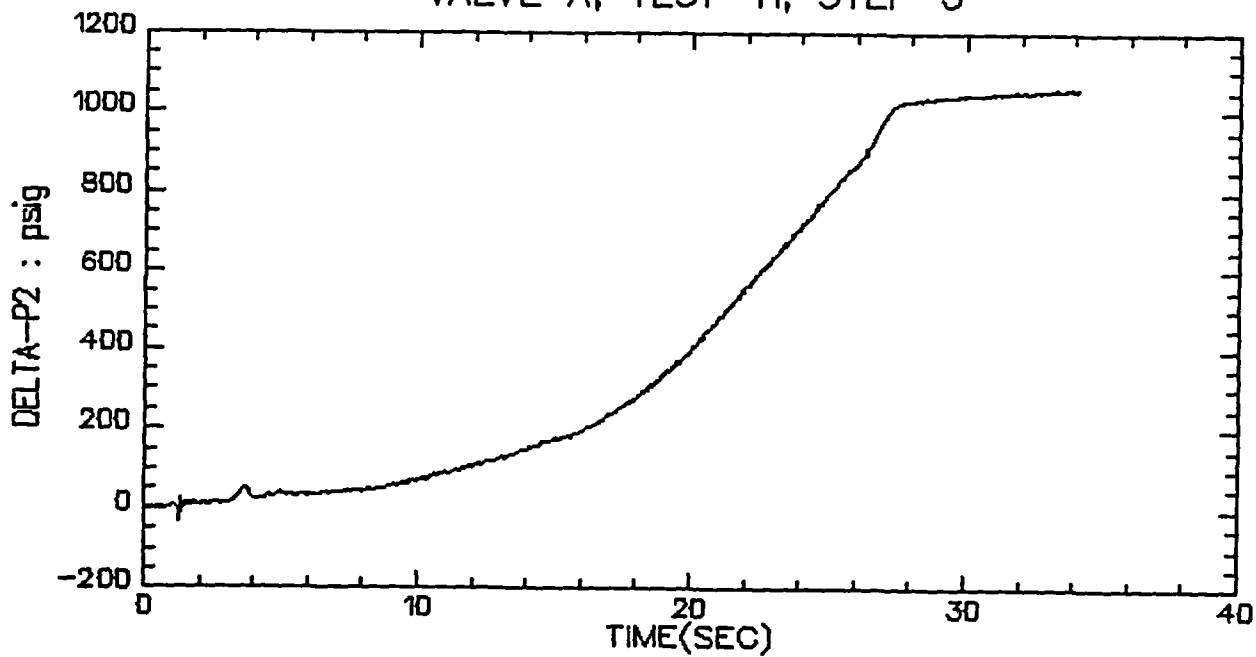

VALVE A, TEST 11, STEP 5

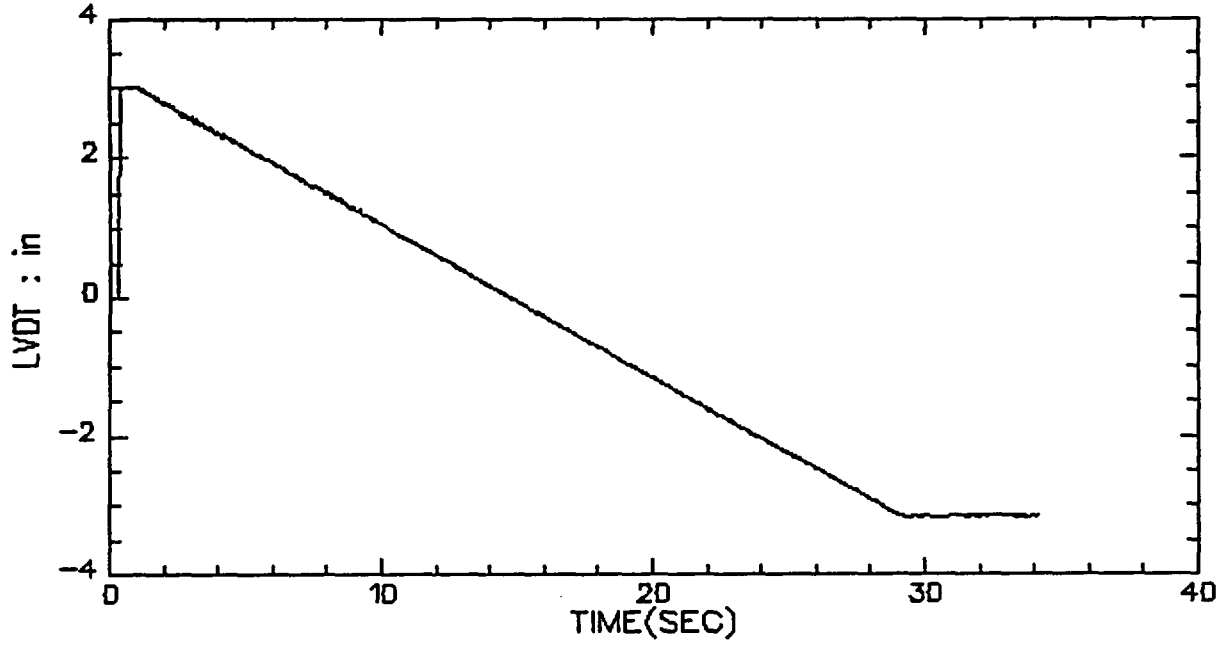

VALVE A, TEST 11, STEP 5

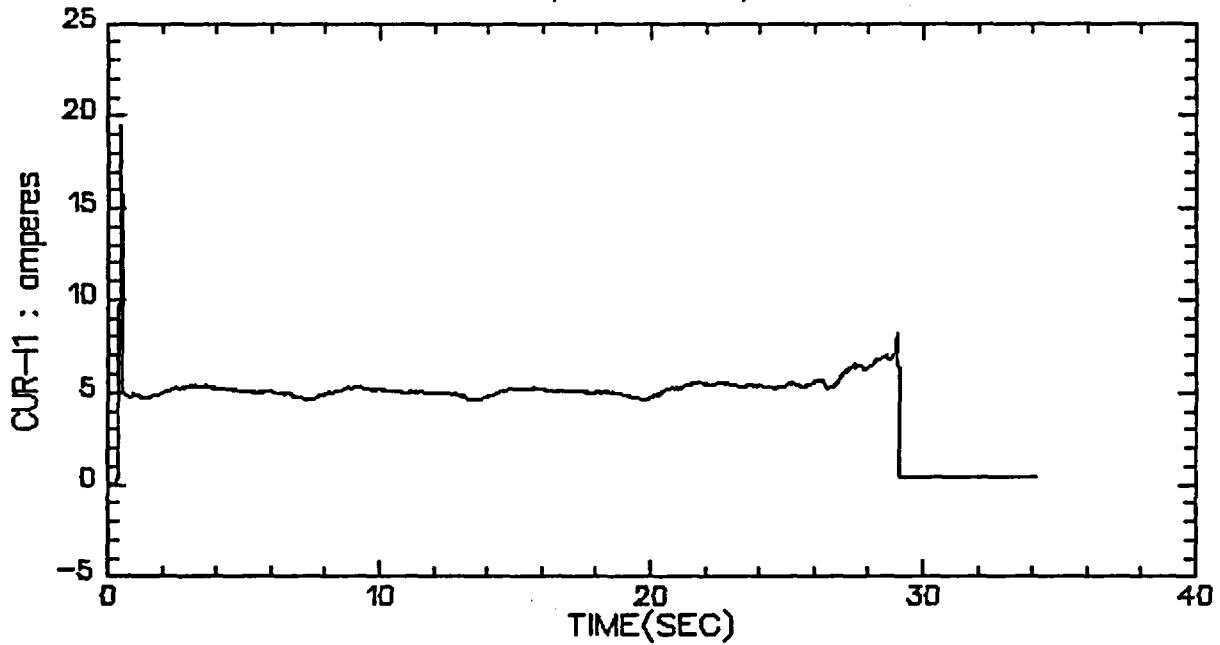

VALVE A, TEST 11, STEP 5

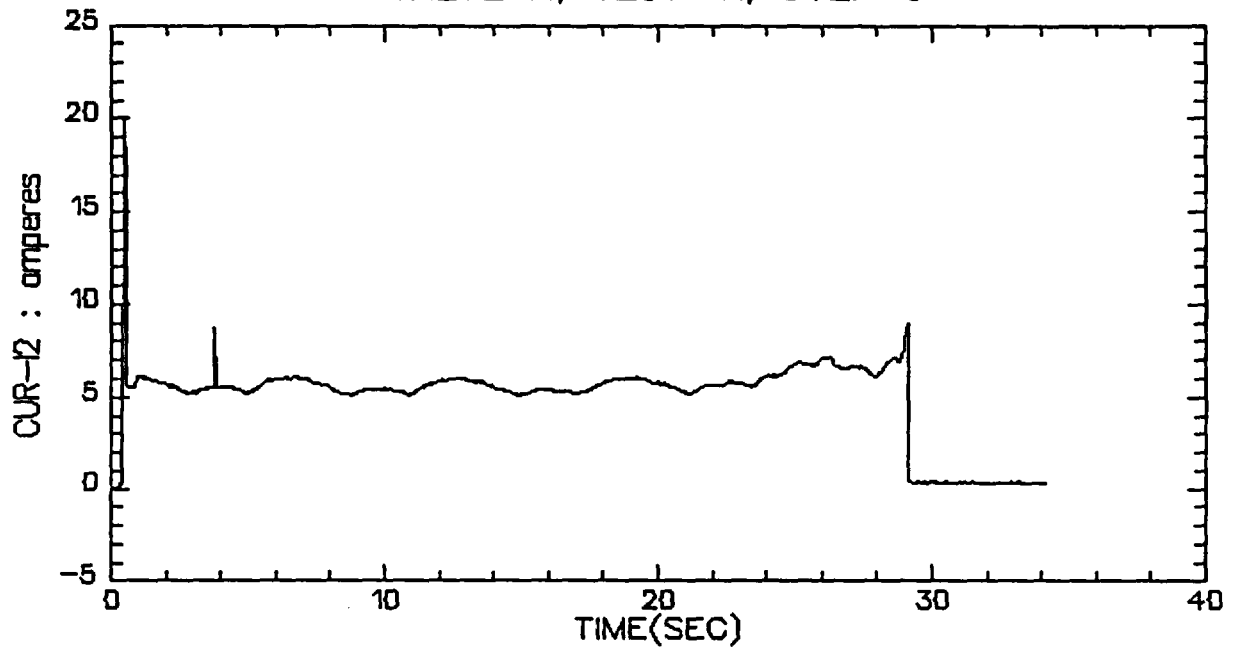

VALVE A, TEST 11, STEP 5

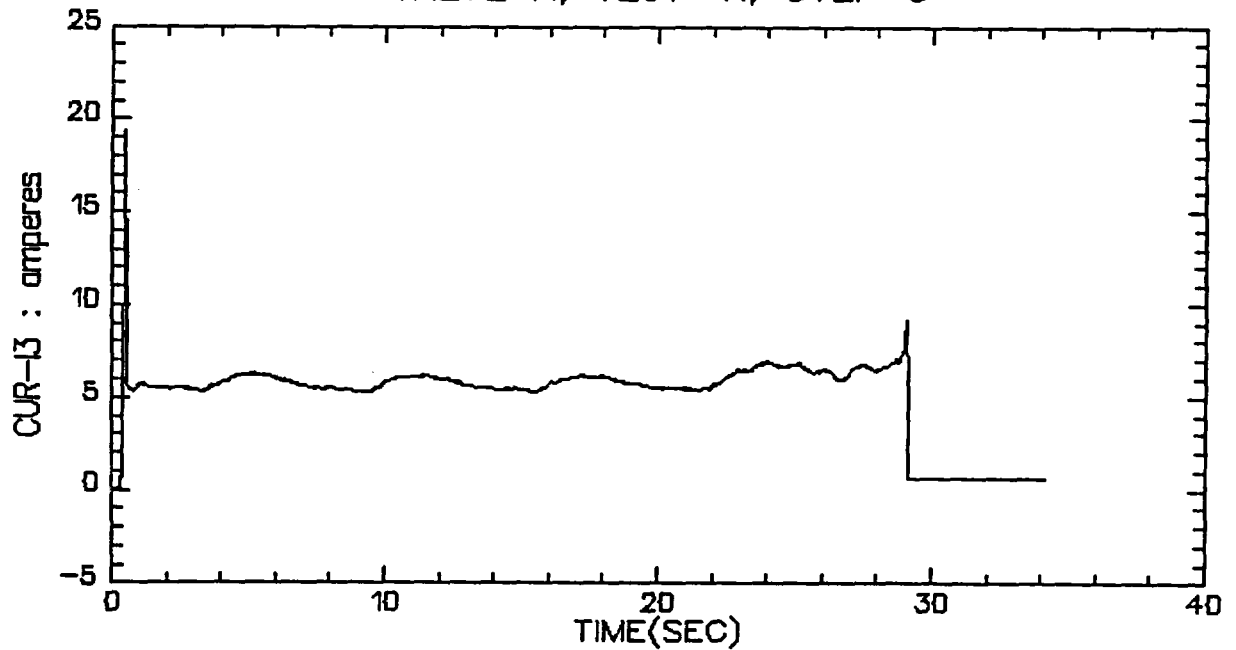

VALVE A, TEST 11, STEP 5

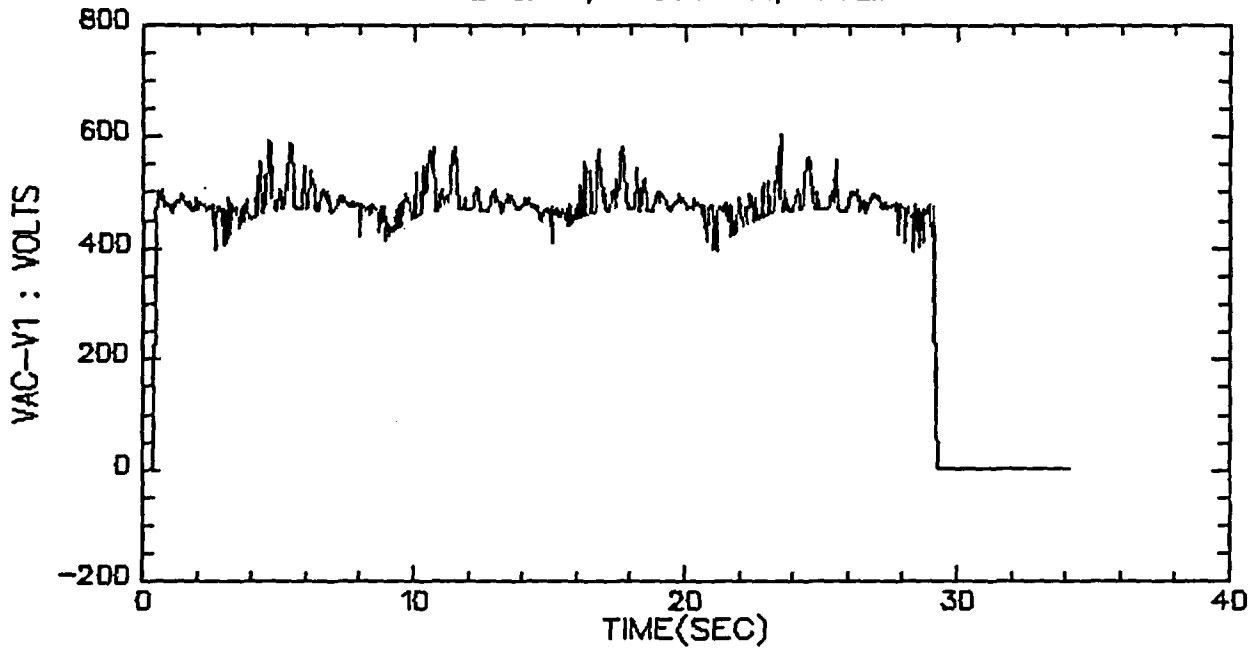

VALVE A, TEST 11, STEP 5

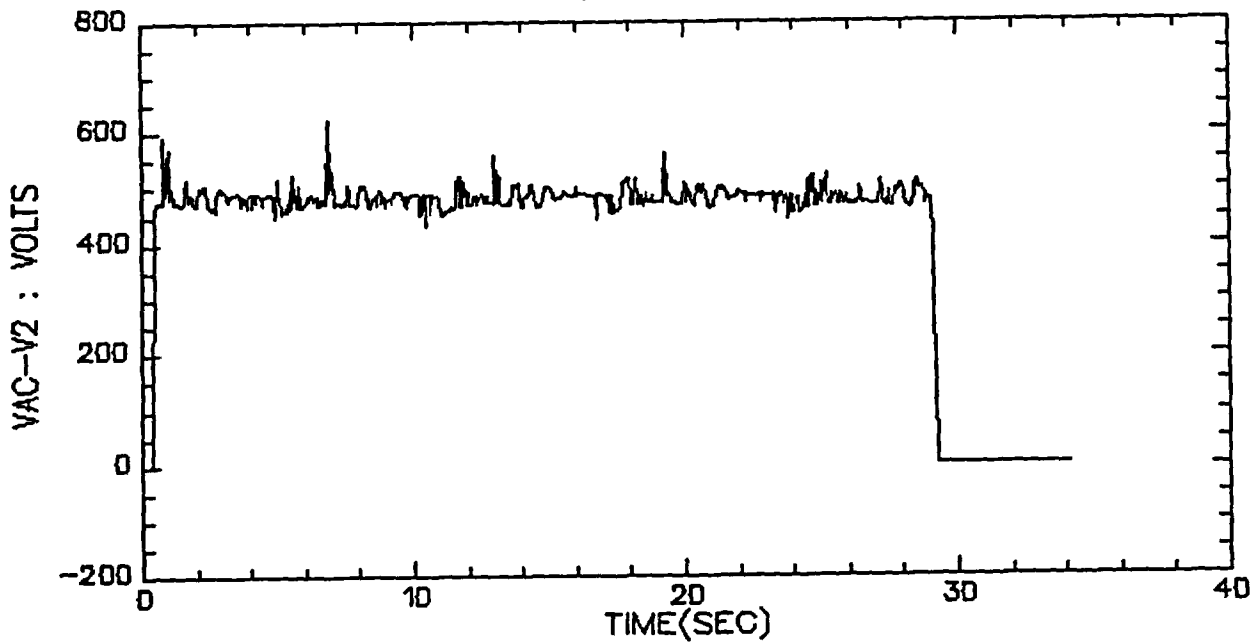

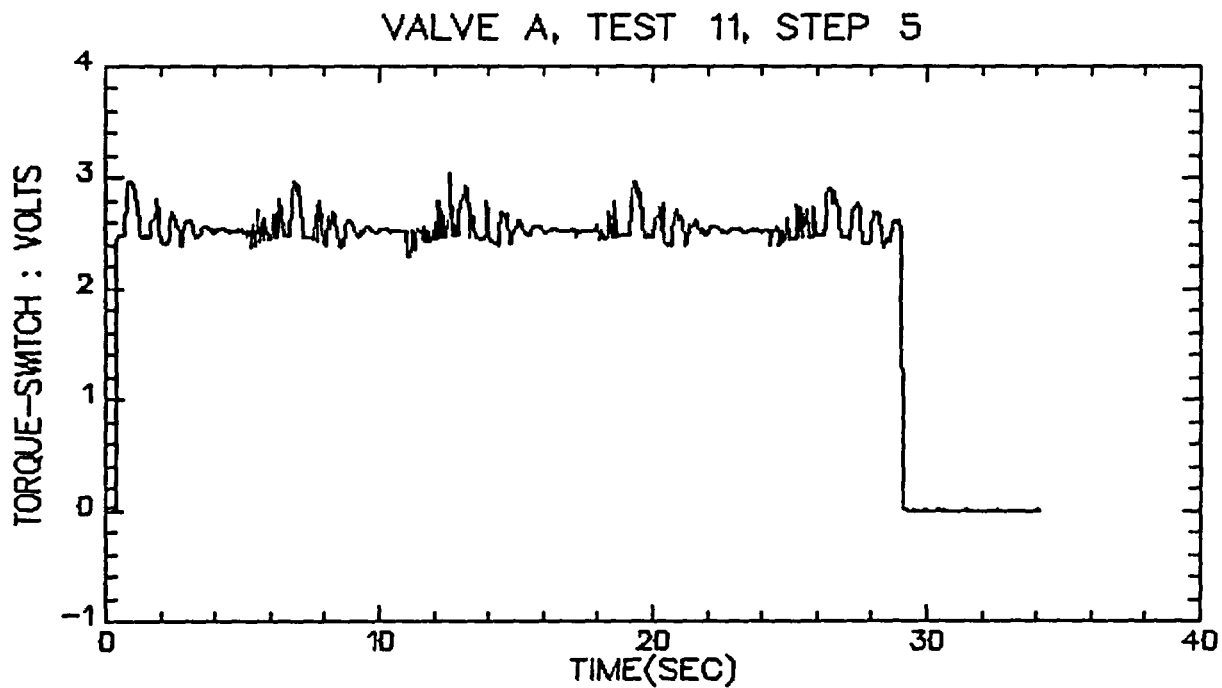
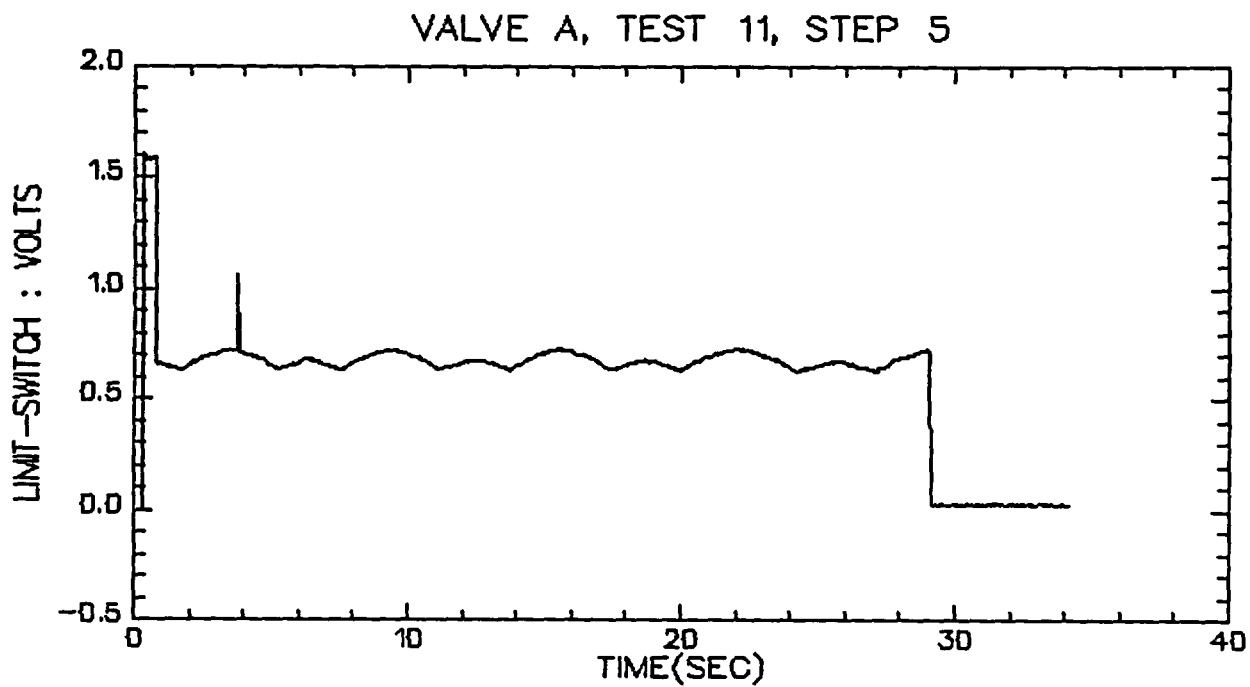

VALVE A, TEST 11, STEP 5

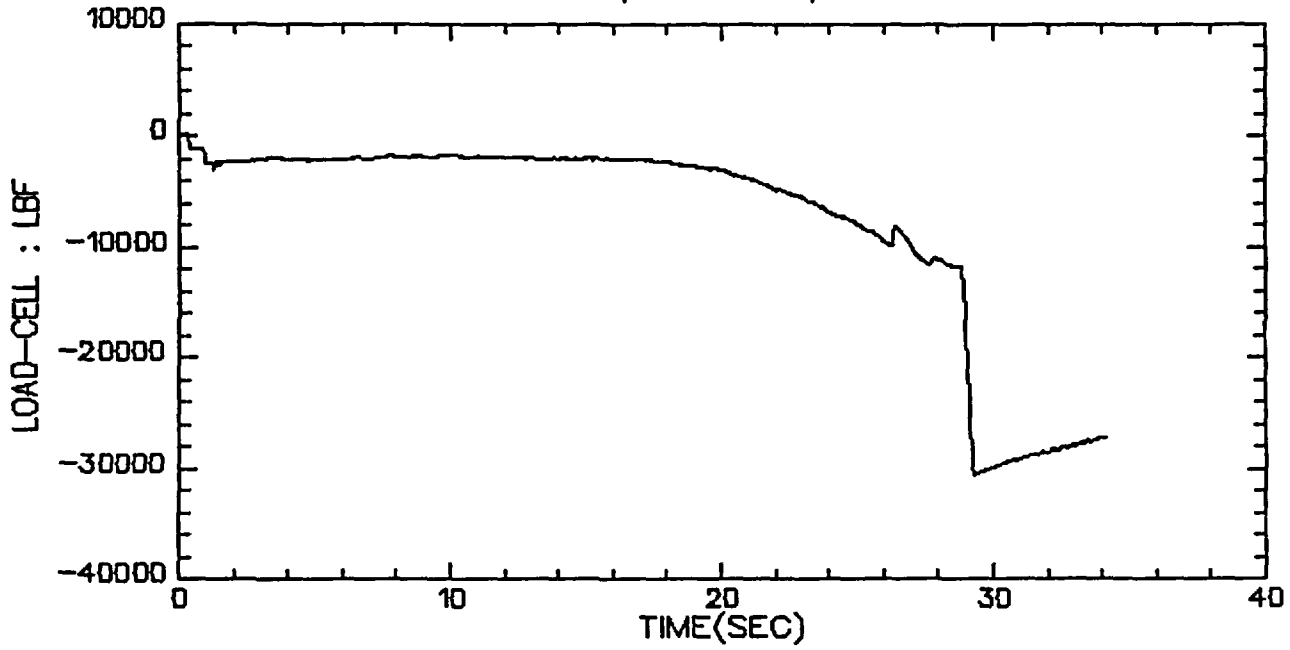

VALVE A, TEST 11, STEP 6&7

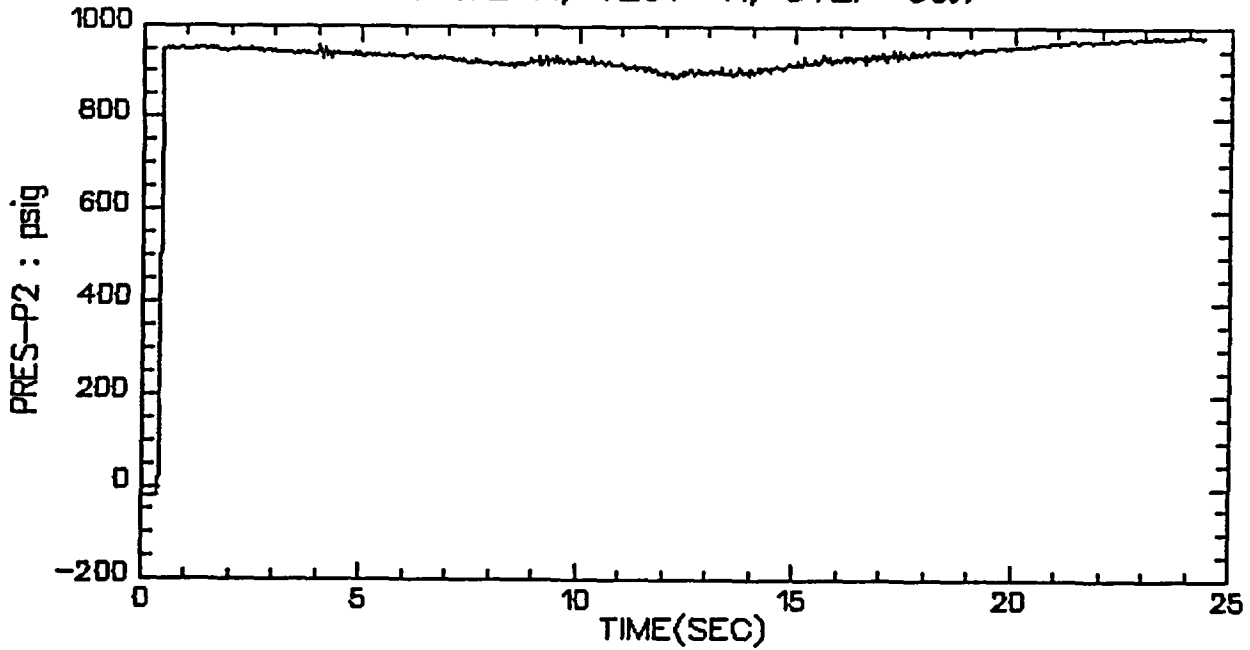

VALVE A, TEST 11, STEP 6&7

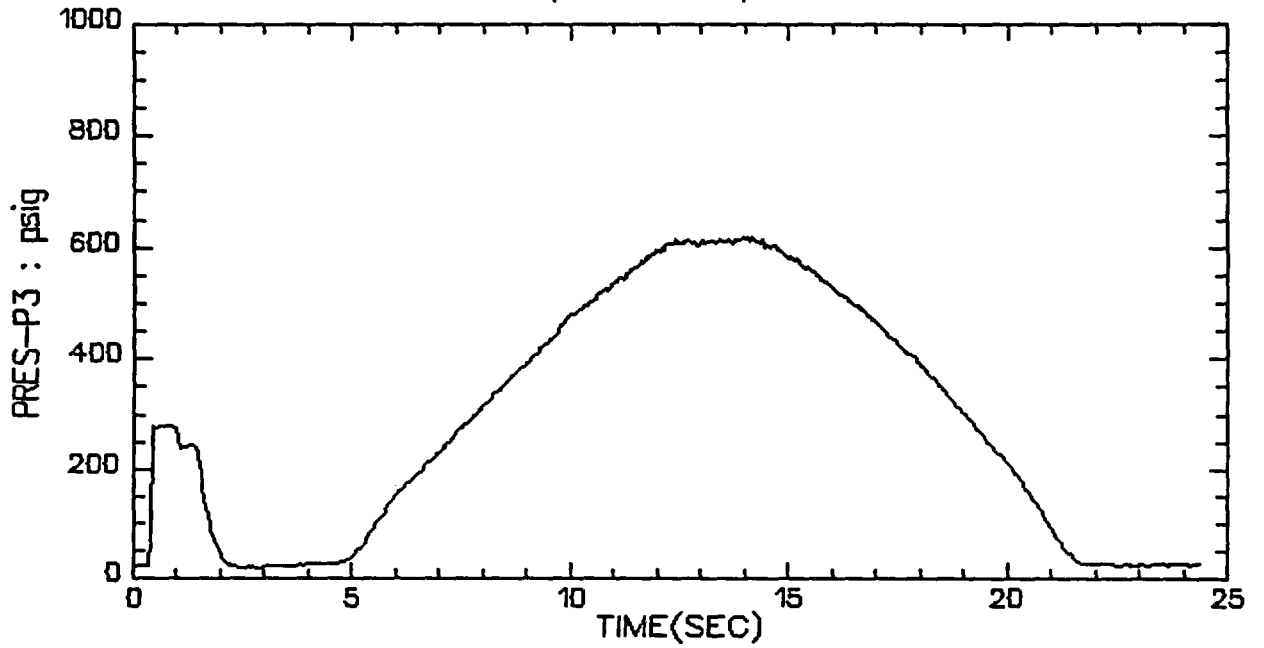

VALVE A, TEST 11, STEP 6&7

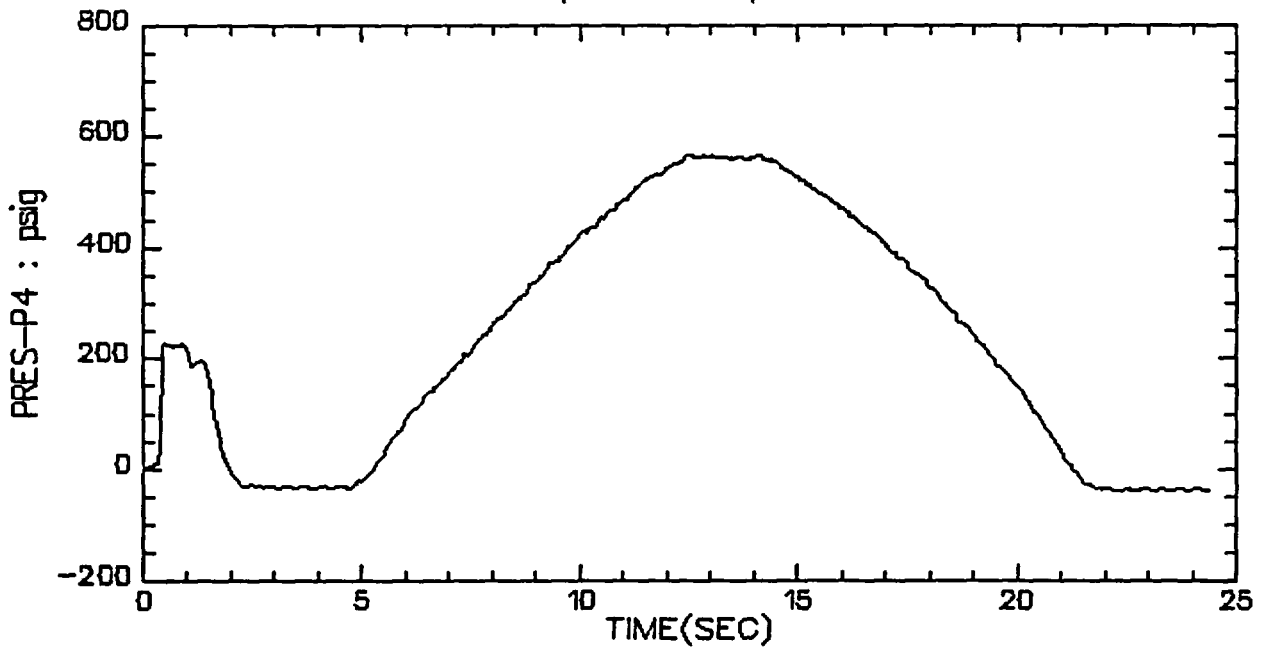

VALVE A, TEST 11, STEP 6&7

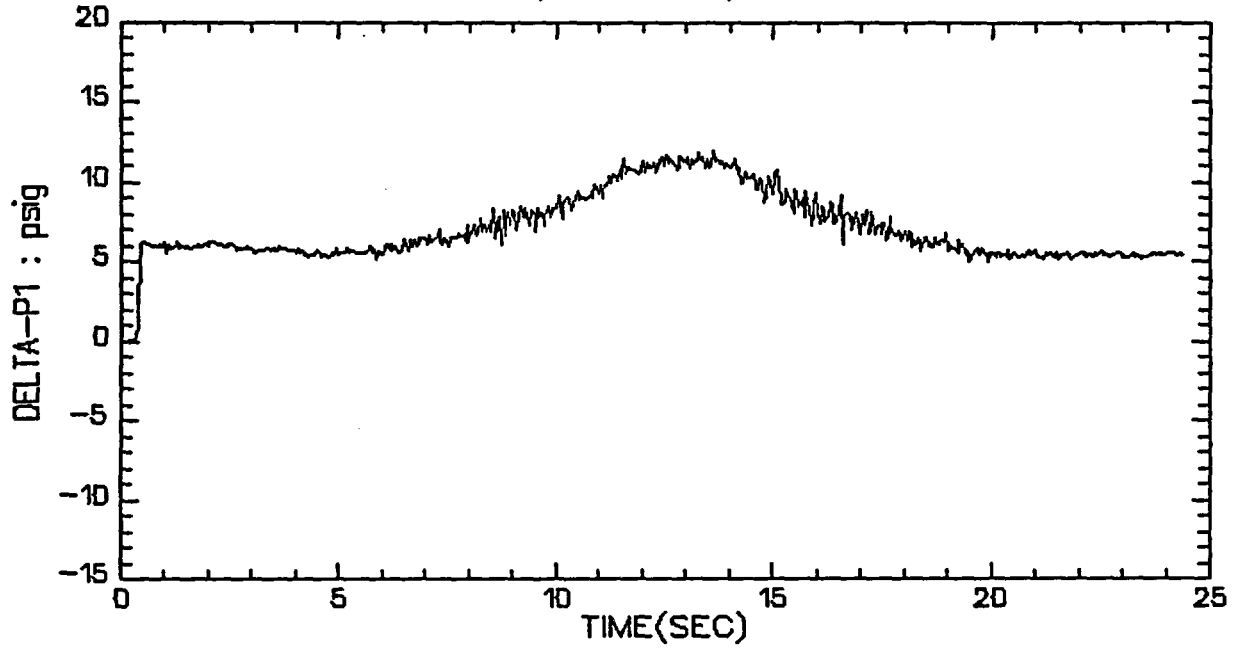

VALVE A, TEST 11, STEP 6&7

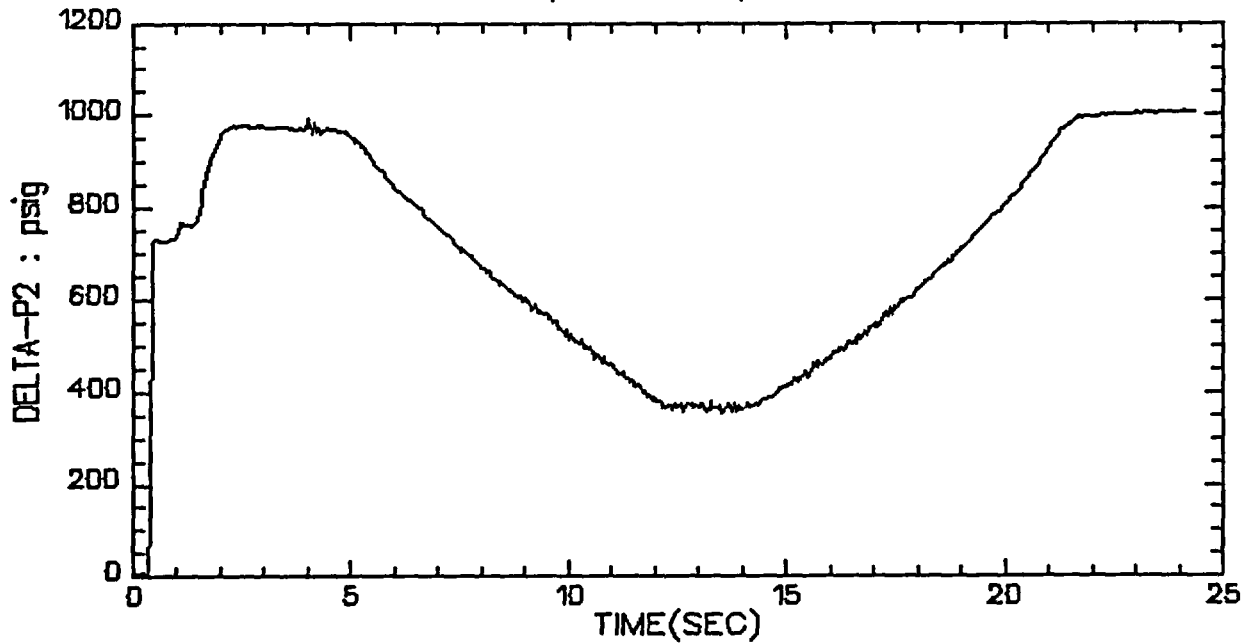

VALVE A, TEST 11, STEP 6&7

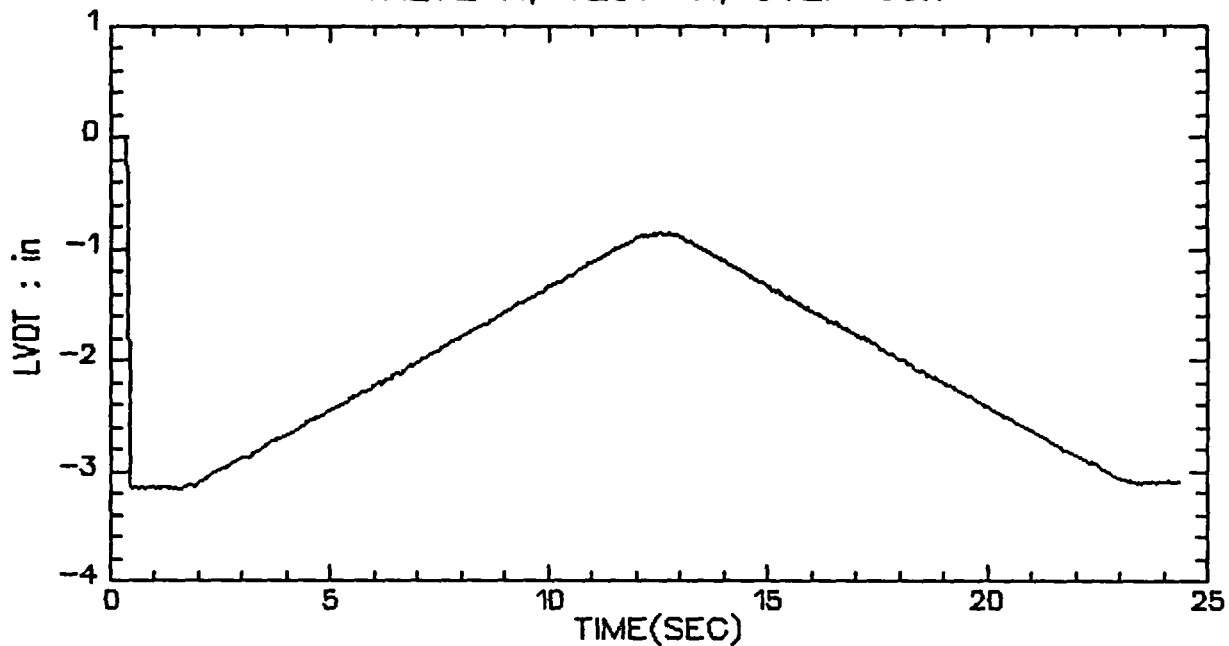

VALVE A, TEST 11, STEP 6&7

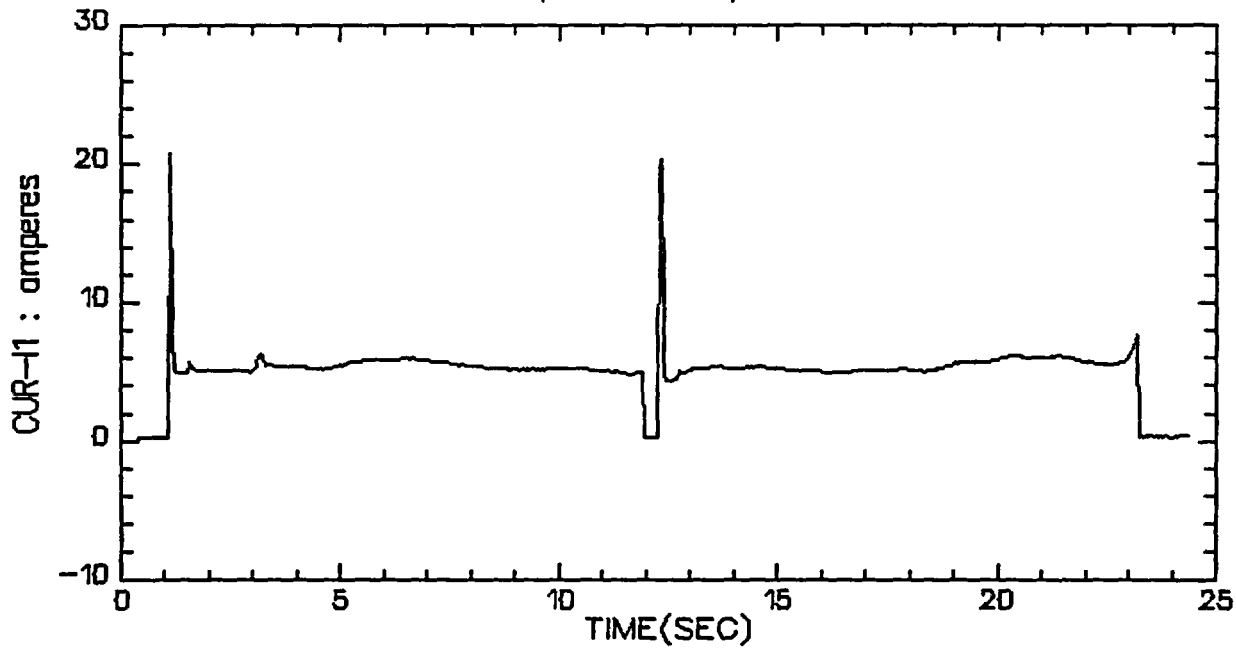

VALVE A, TEST 11, STEP 6&7

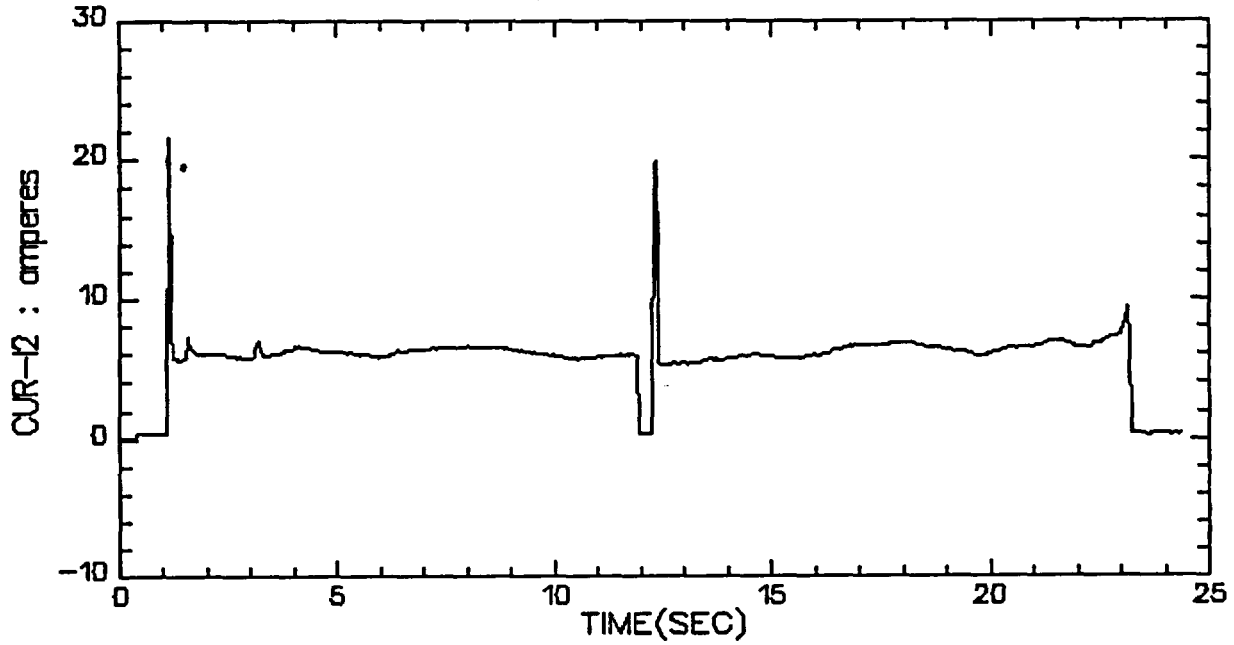

VALVE A, TEST 11, STEP 6&7

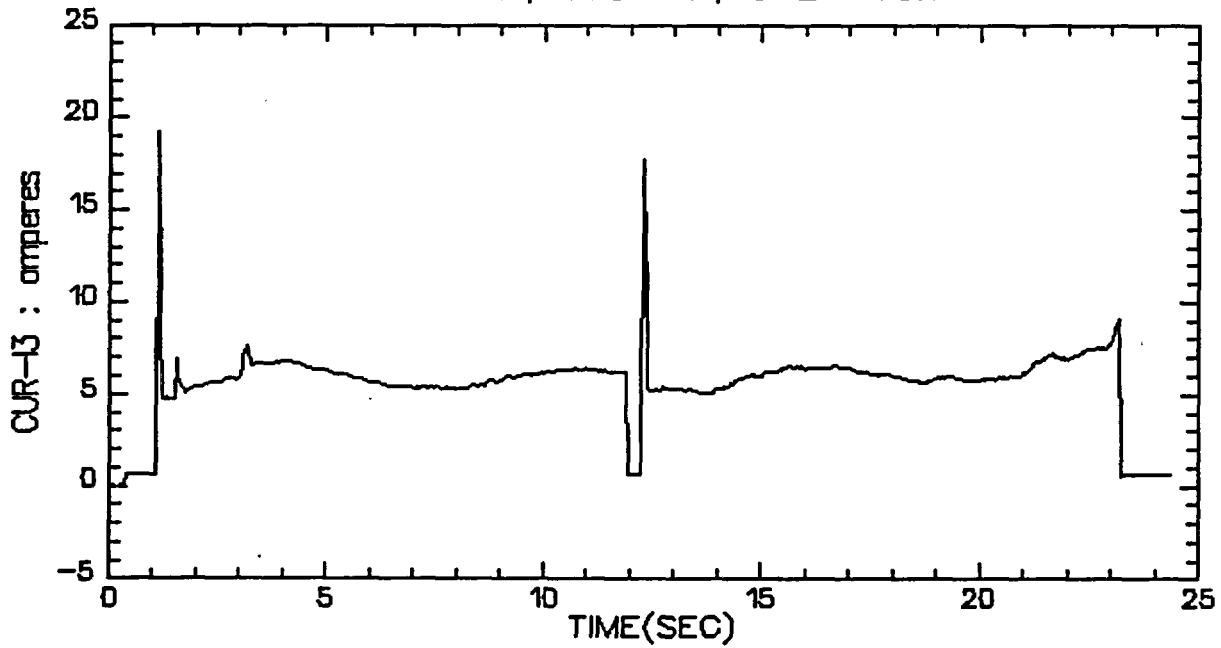

VALVE A, TEST 11, STEP 6&7

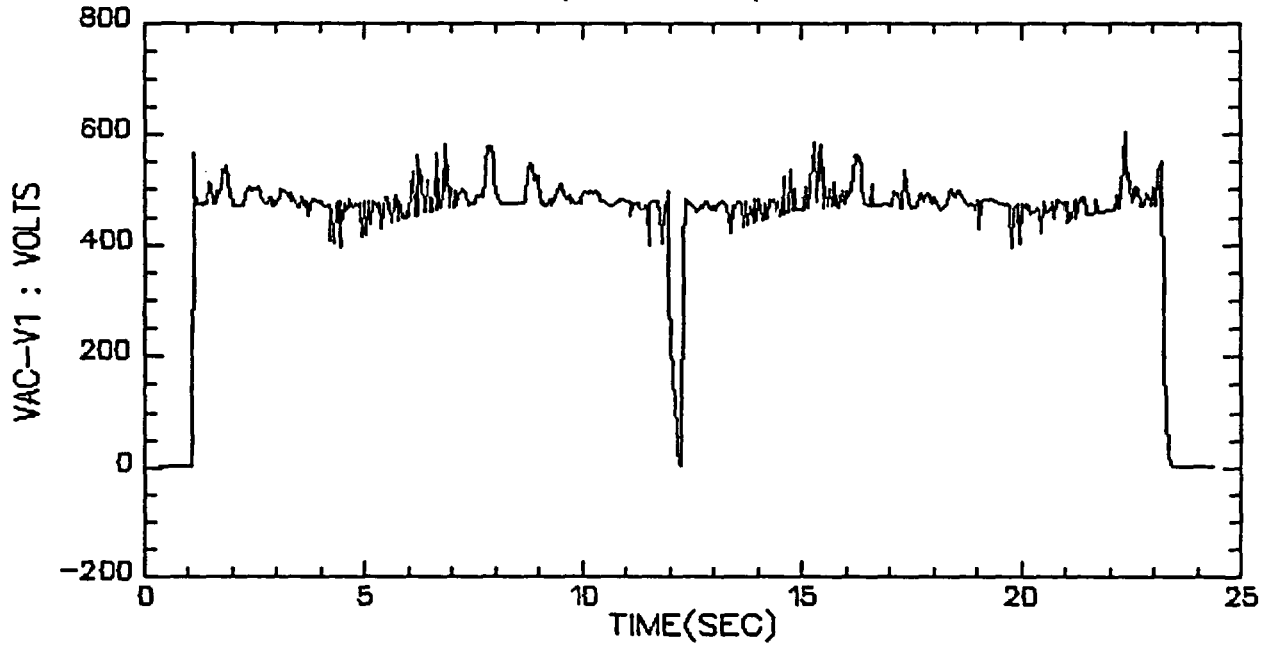

VALVE A, TEST 11, STEP 6&7

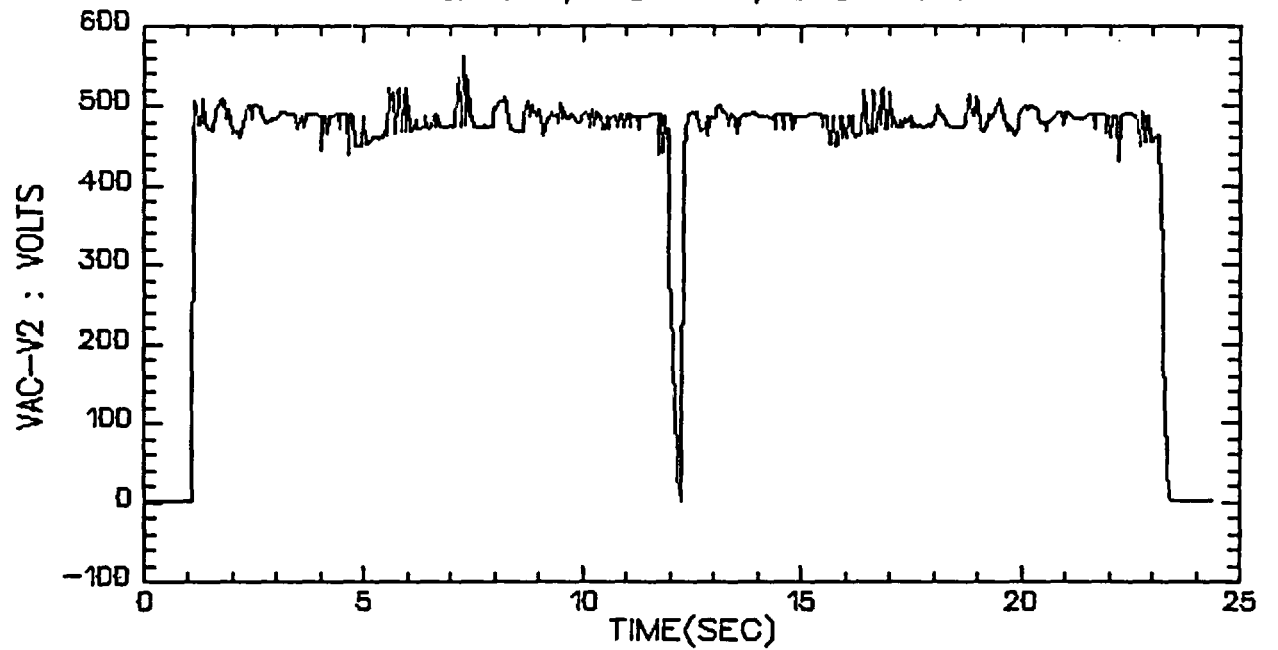

VALVE A, TEST 11, STEP 6&7

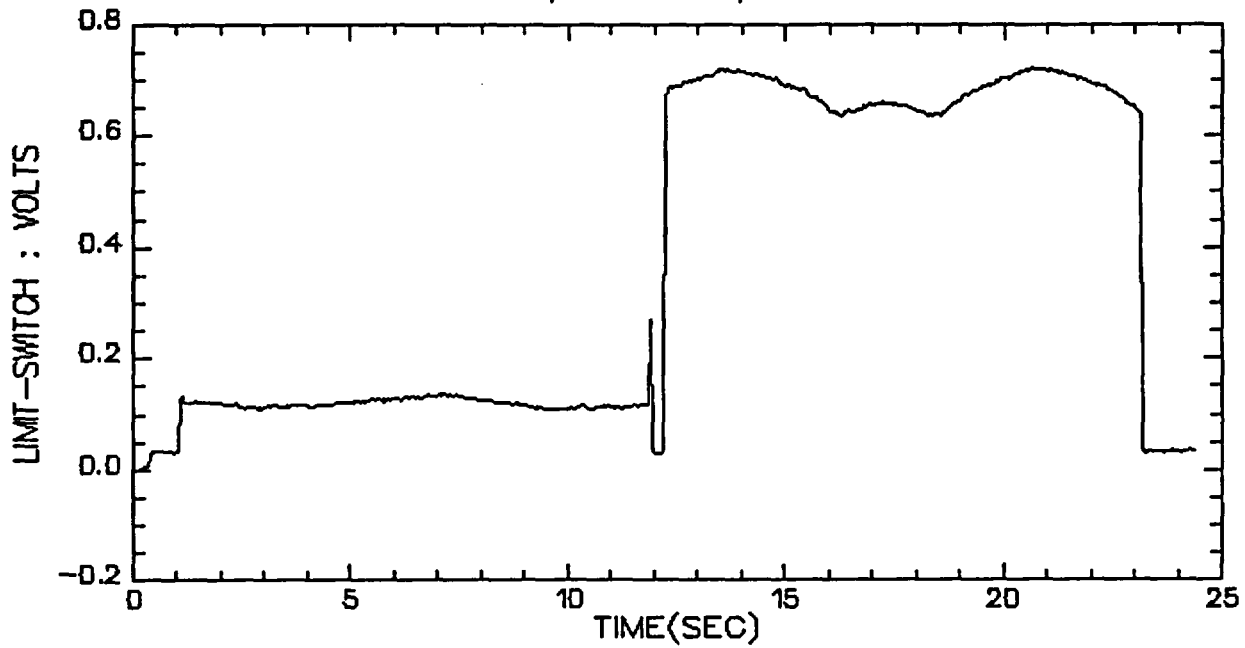

VALVE A, TEST 11, STEP 6&7

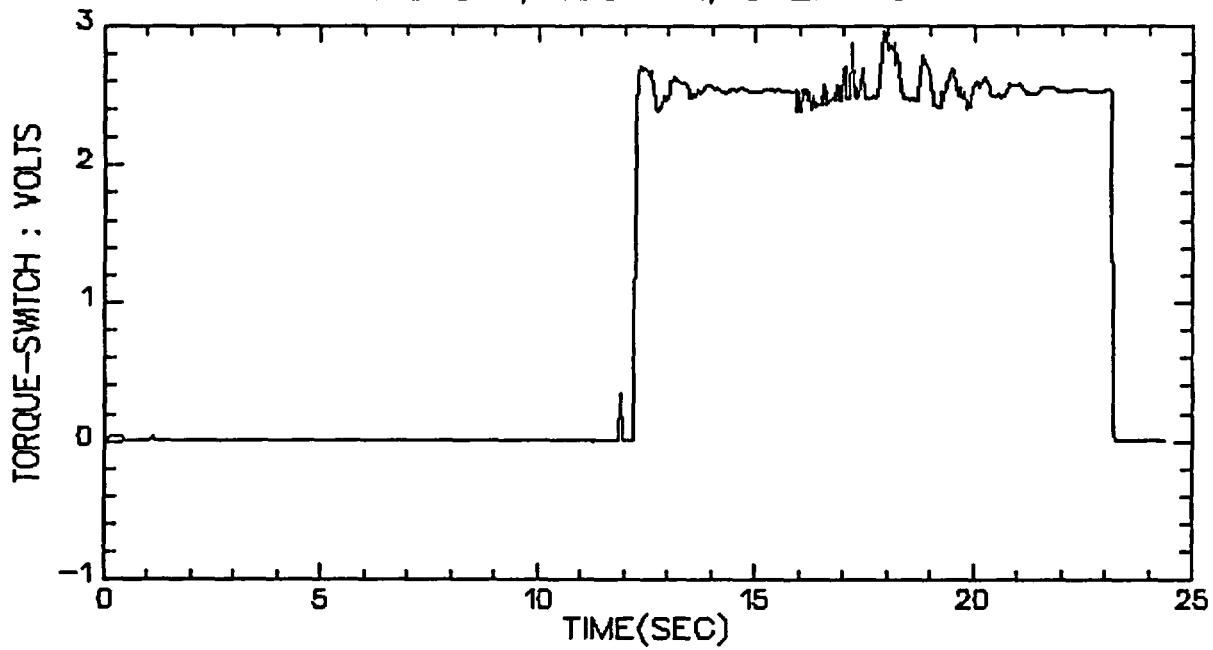

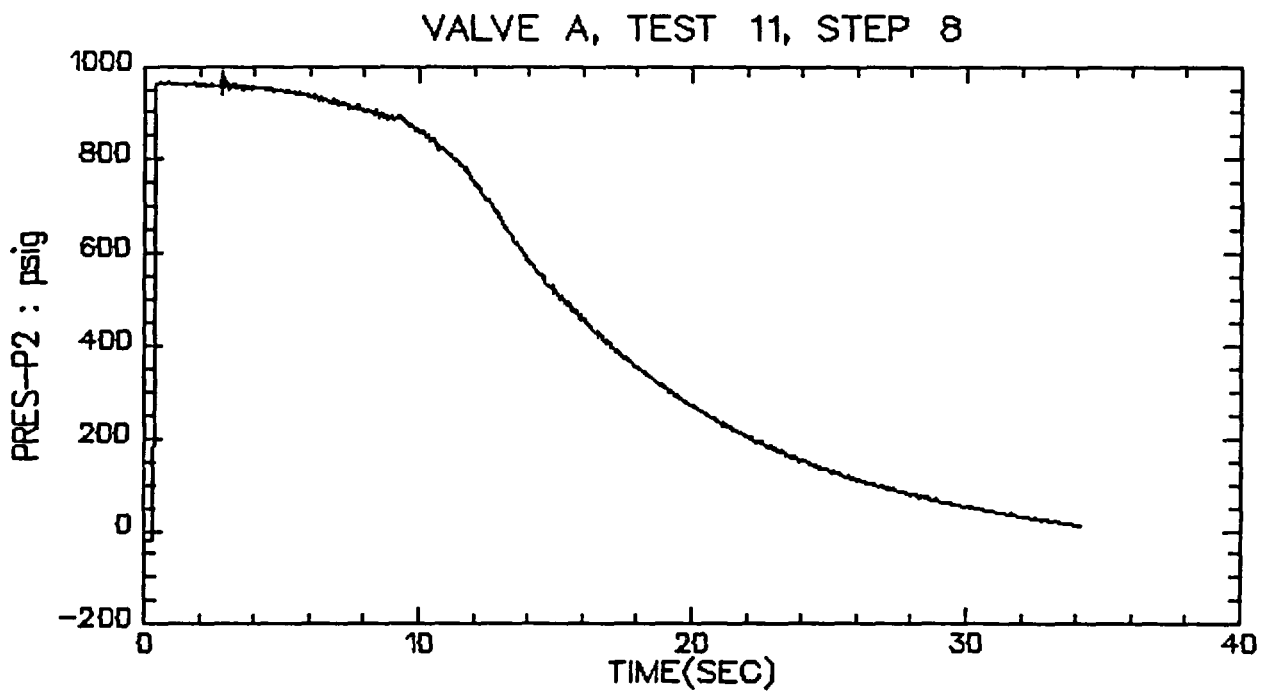
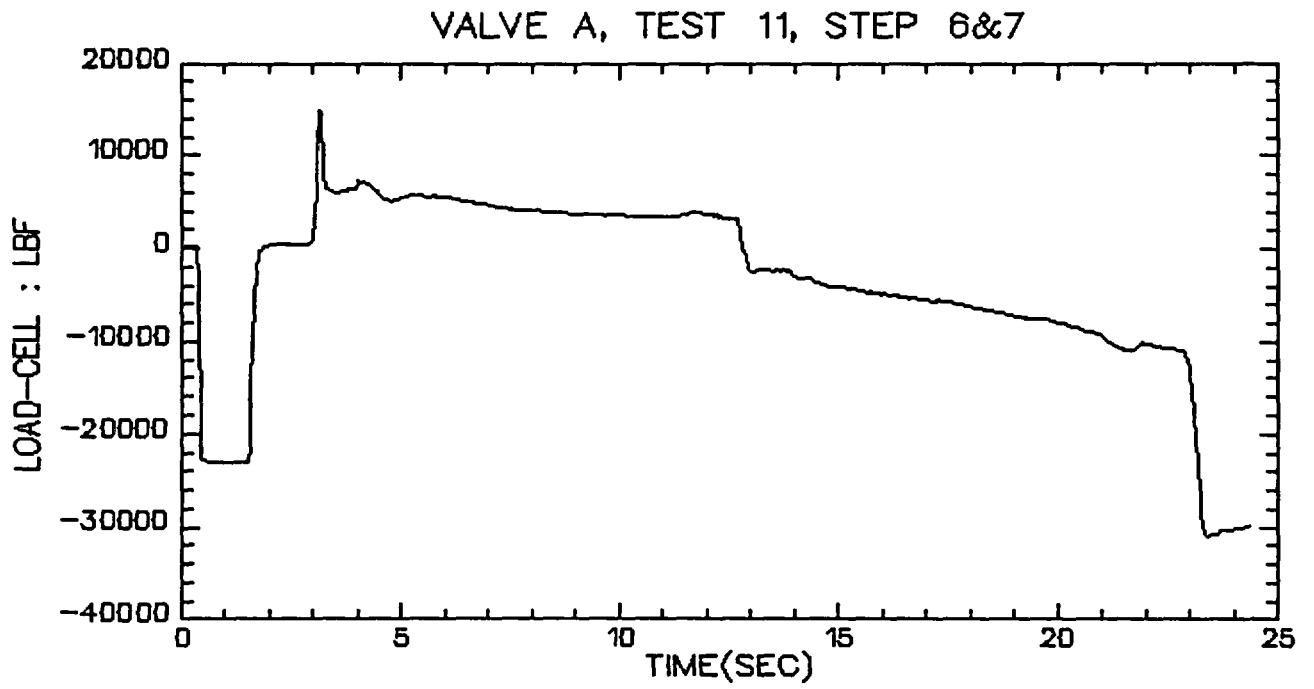

VALVE A, TEST 11, STEP 8

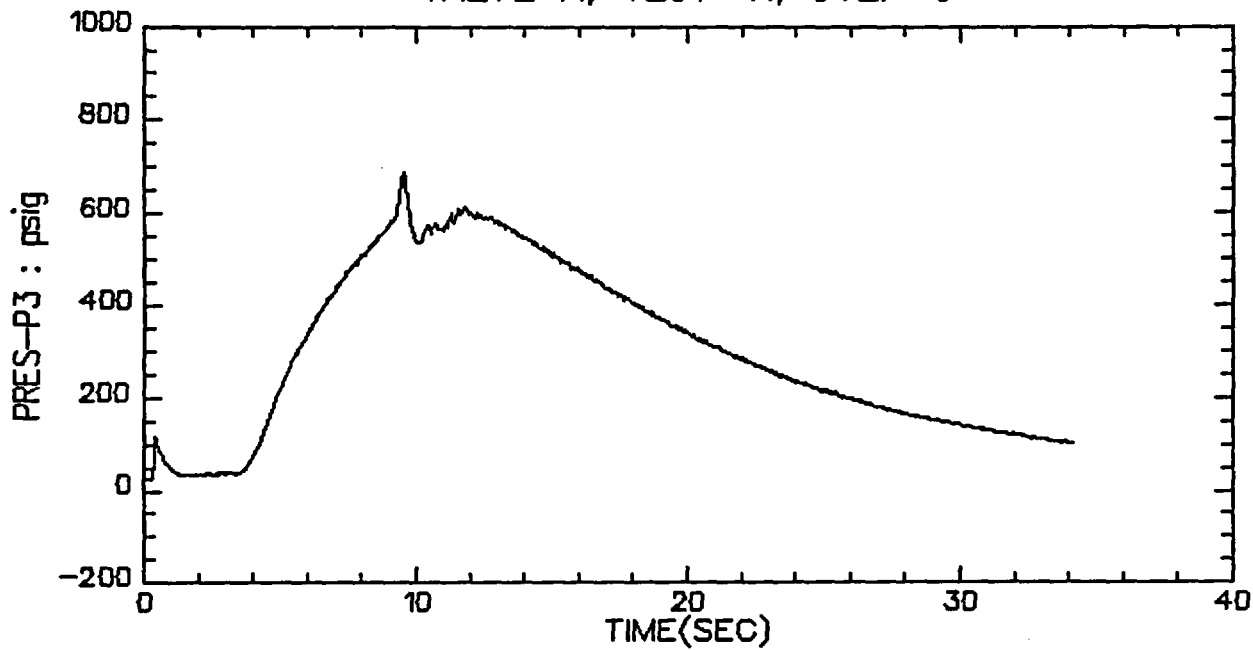

VALVE A, TEST 11, STEP 8

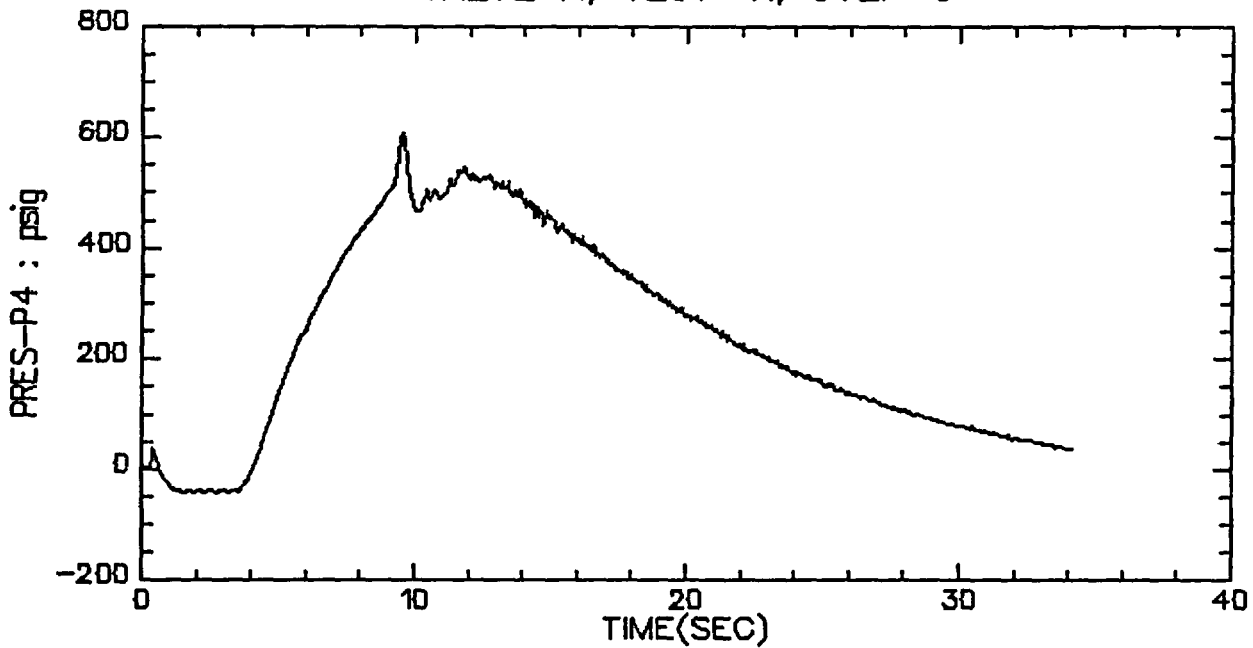

VALVE A, TEST 11, STEP 8

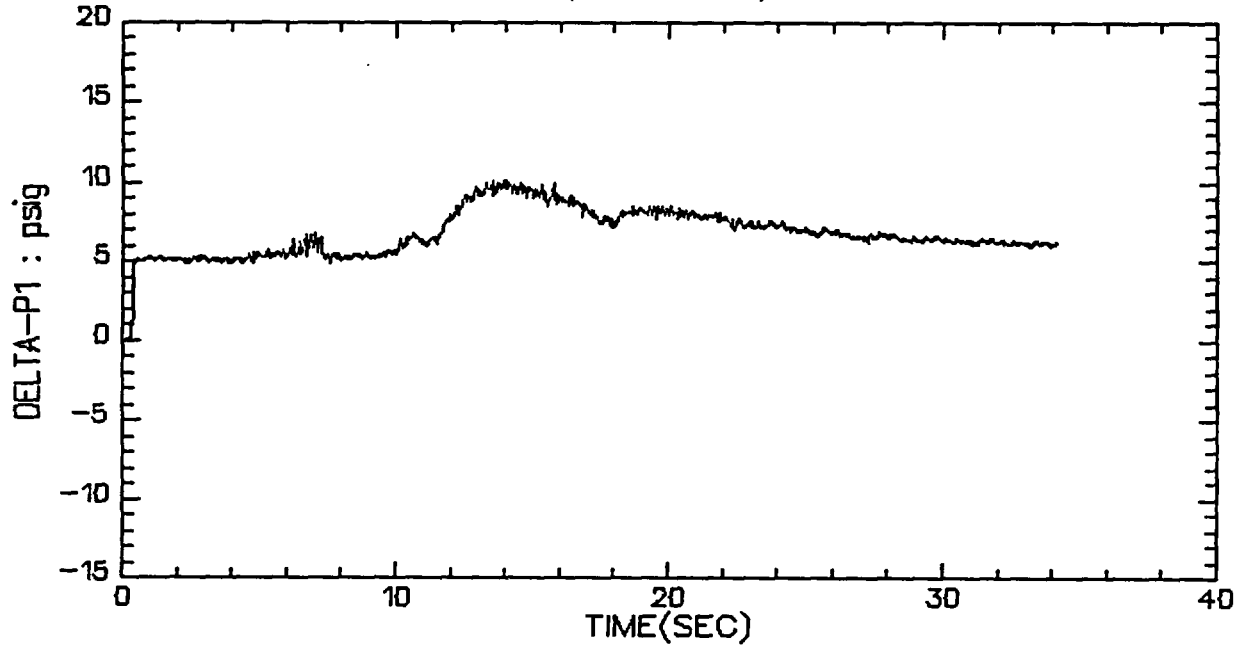

VALVE A, TEST 11, STEP 8

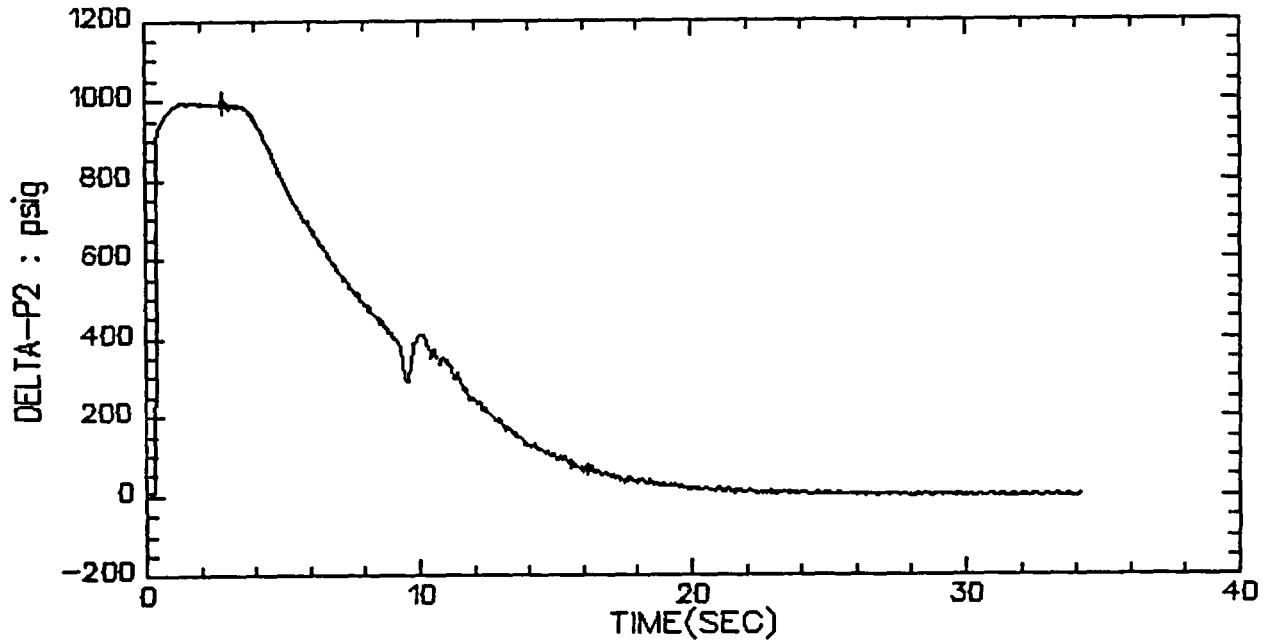

VALVE A, TEST 11, STEP 8

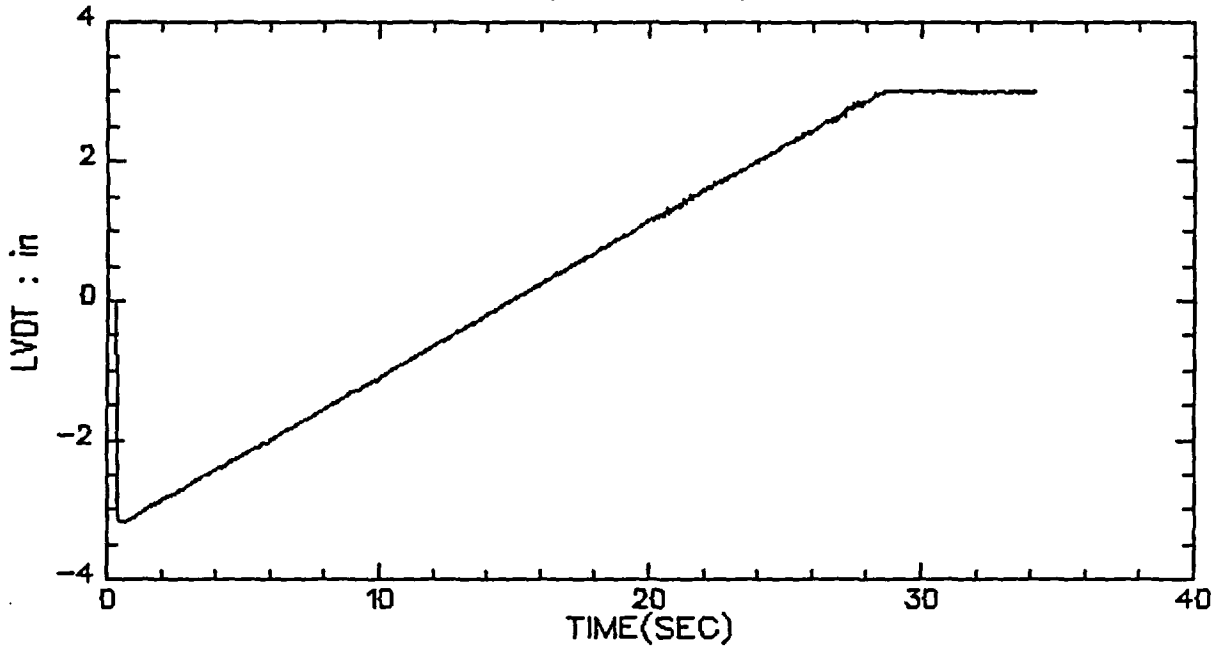

VALVE A, TEST 11, STEP 8

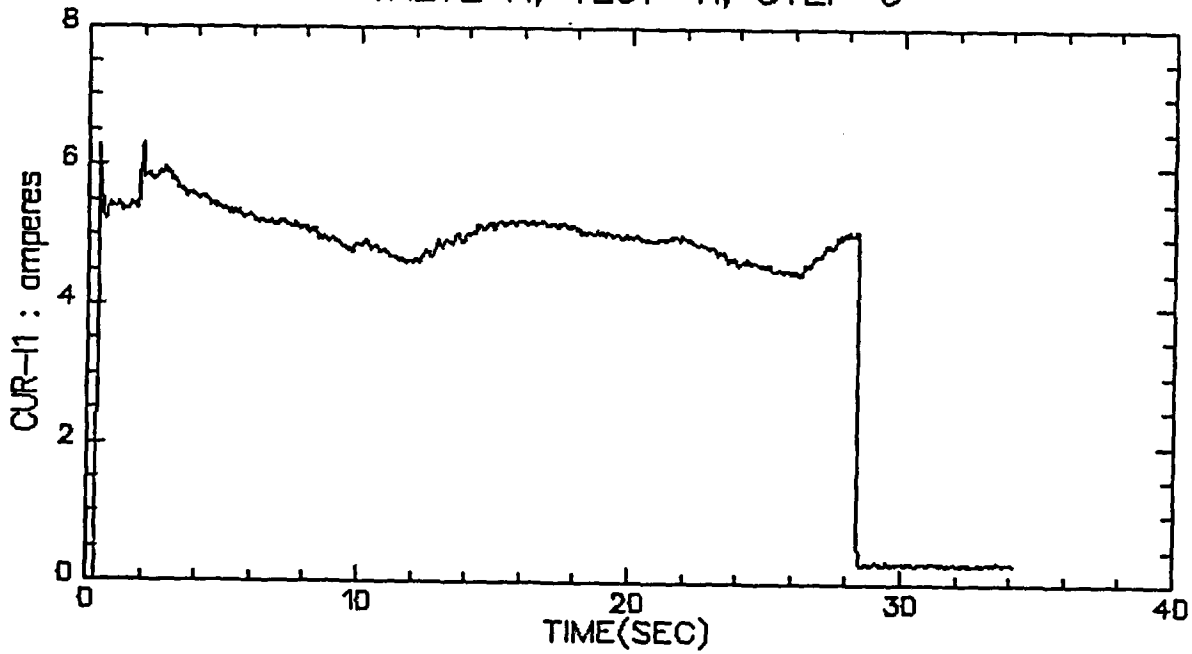

VALVE A, TEST 11, STEP 8

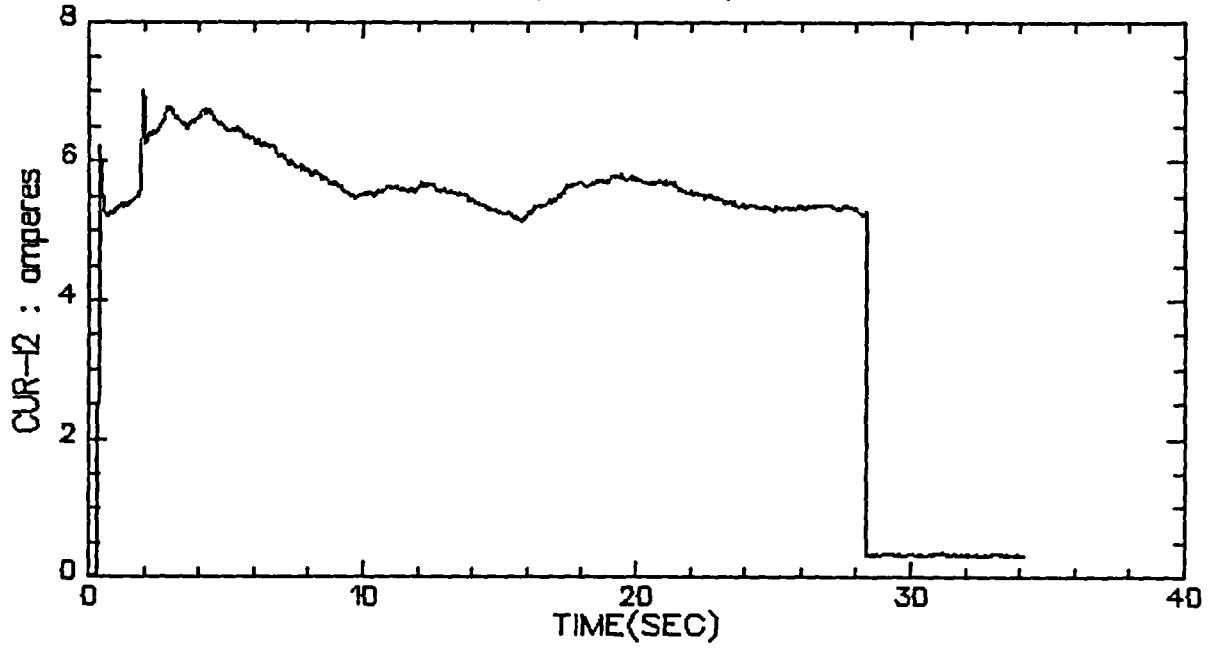

VALVE A, TEST 11, STEP 8

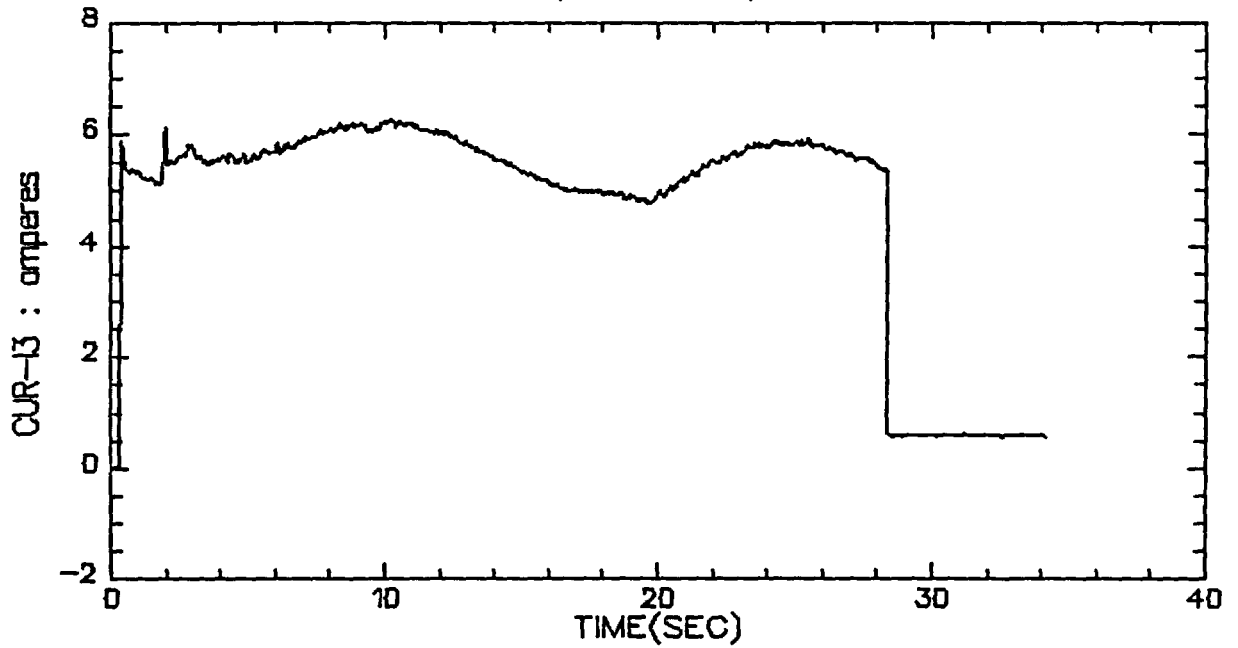

VALVE A, TEST 11, STEP 8

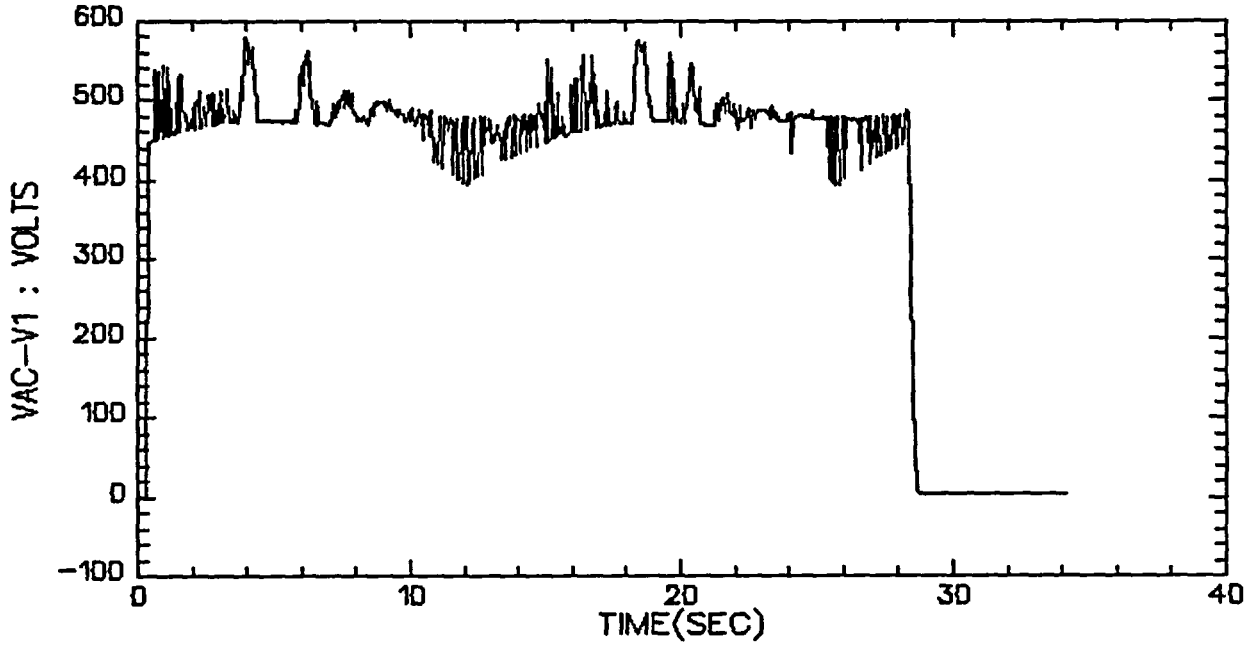

VALVE A, TEST 11, STEP 8

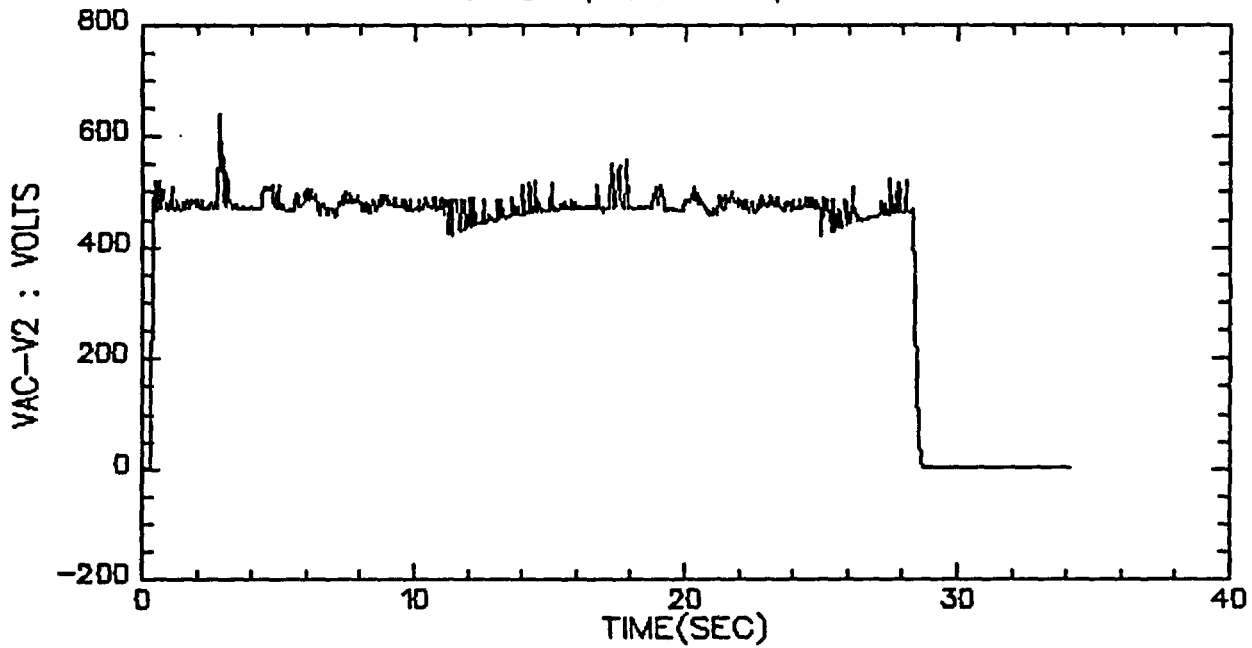

VALVE A, TEST 11, STEP 8

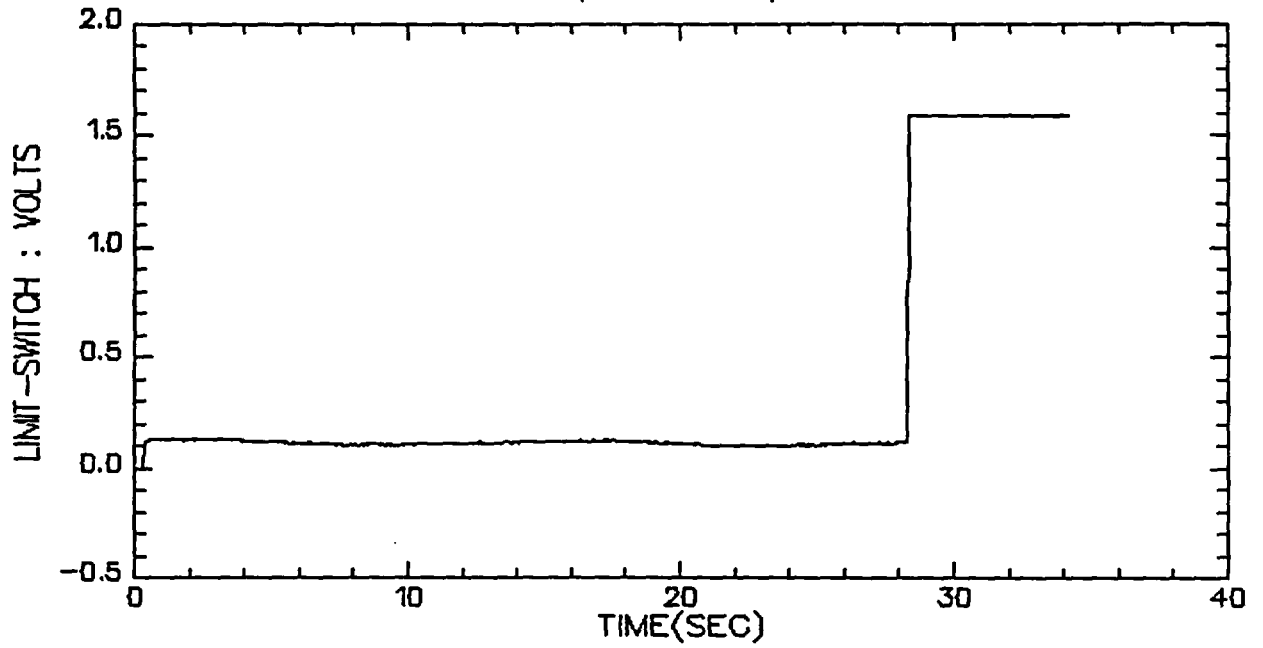

VALVE A, TEST 11, STEP 8

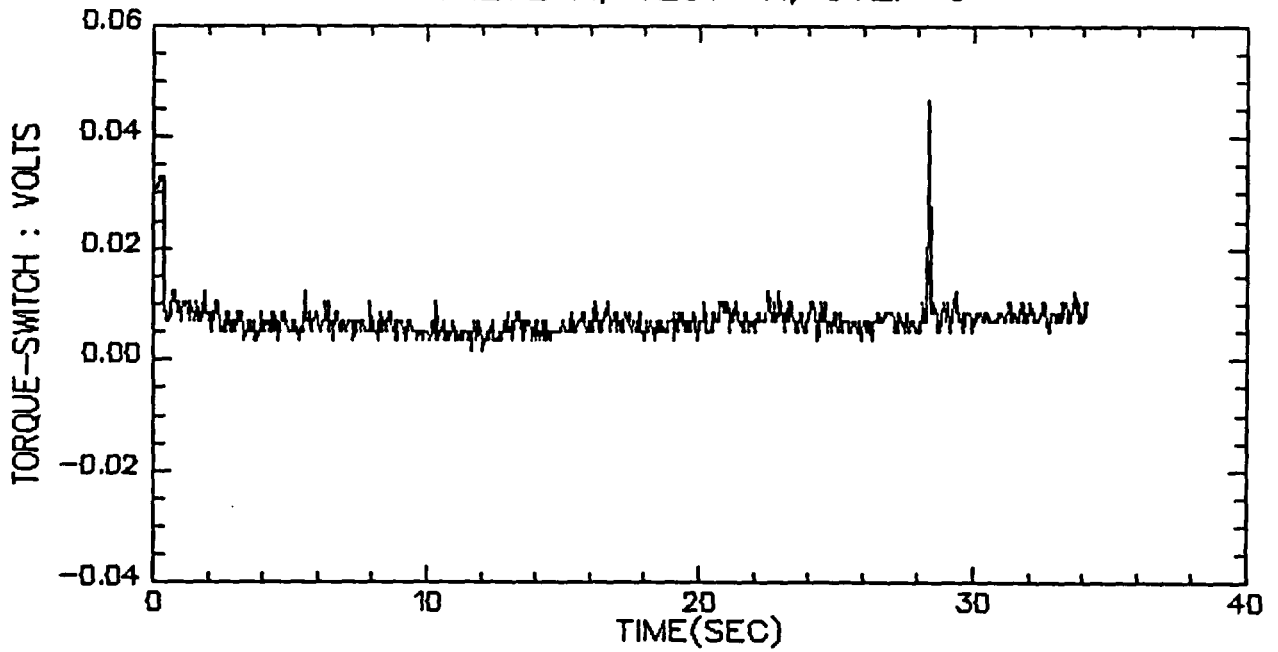

VALVE A, TEST 11, STEP 8

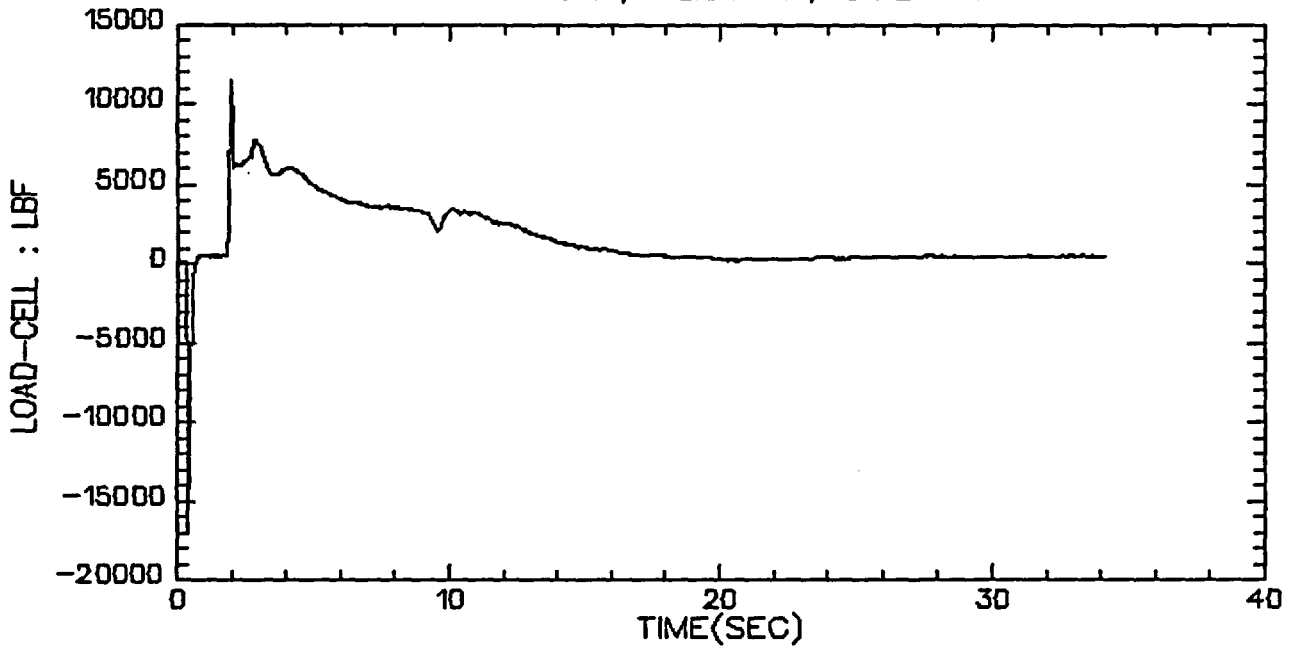

VALVE A, TEST 11, STEP 9

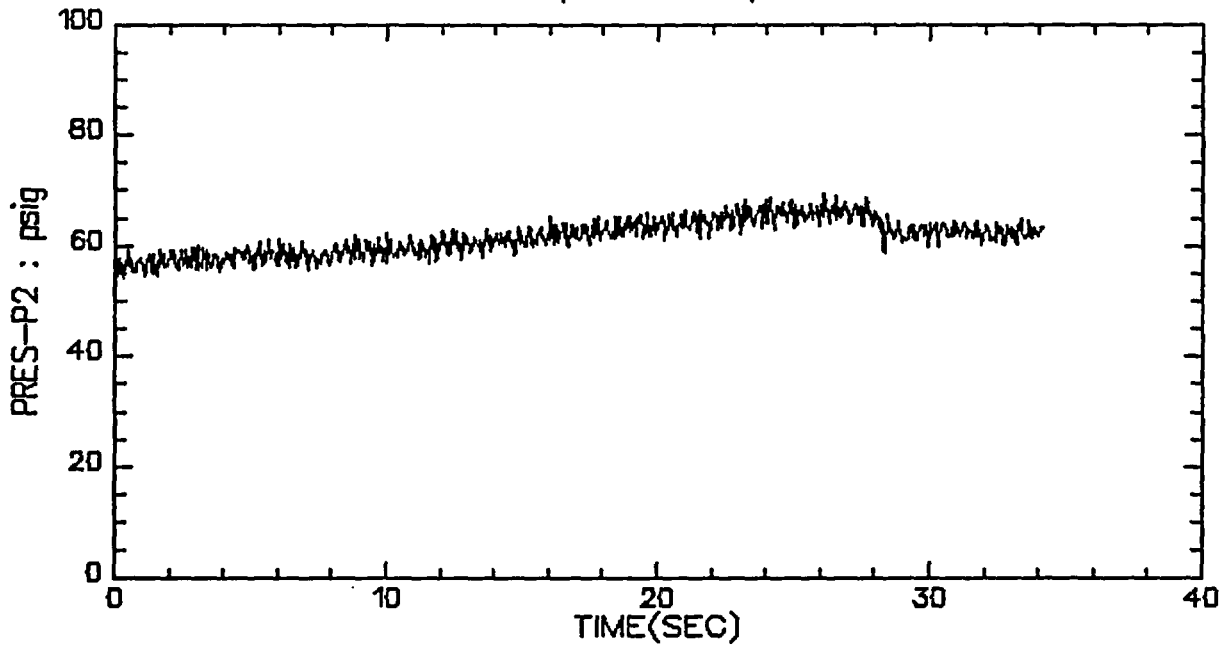

VALVE A, TEST 11, STEP 9

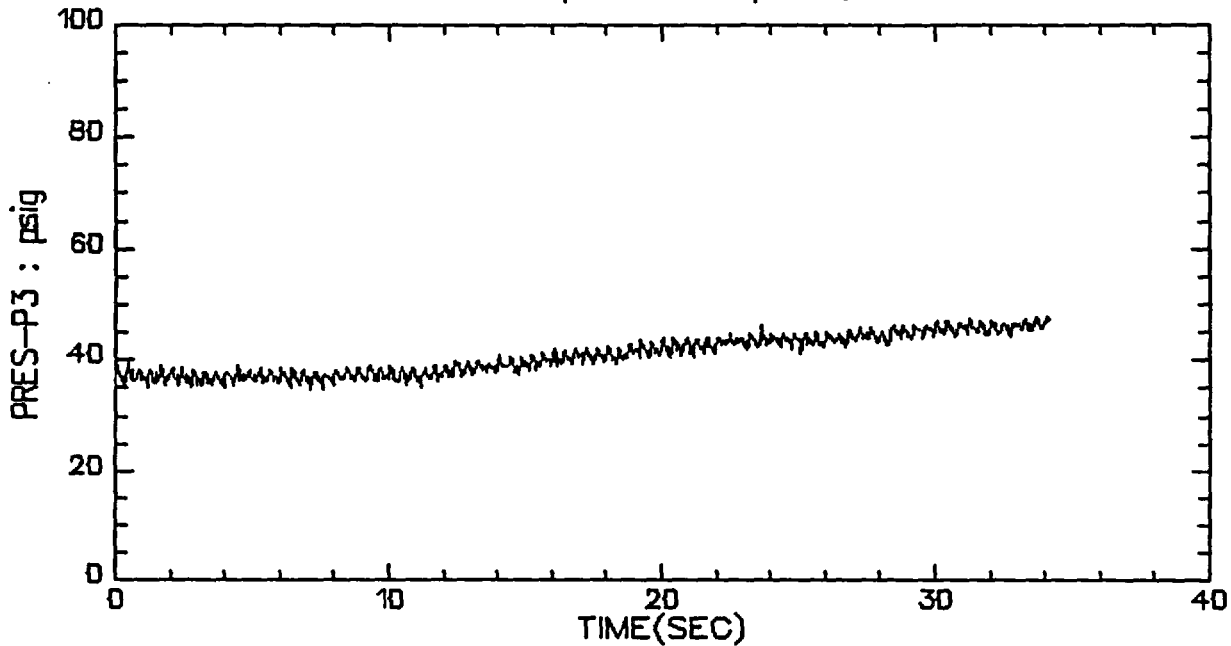

VALVE A, TEST 11, STEP 9

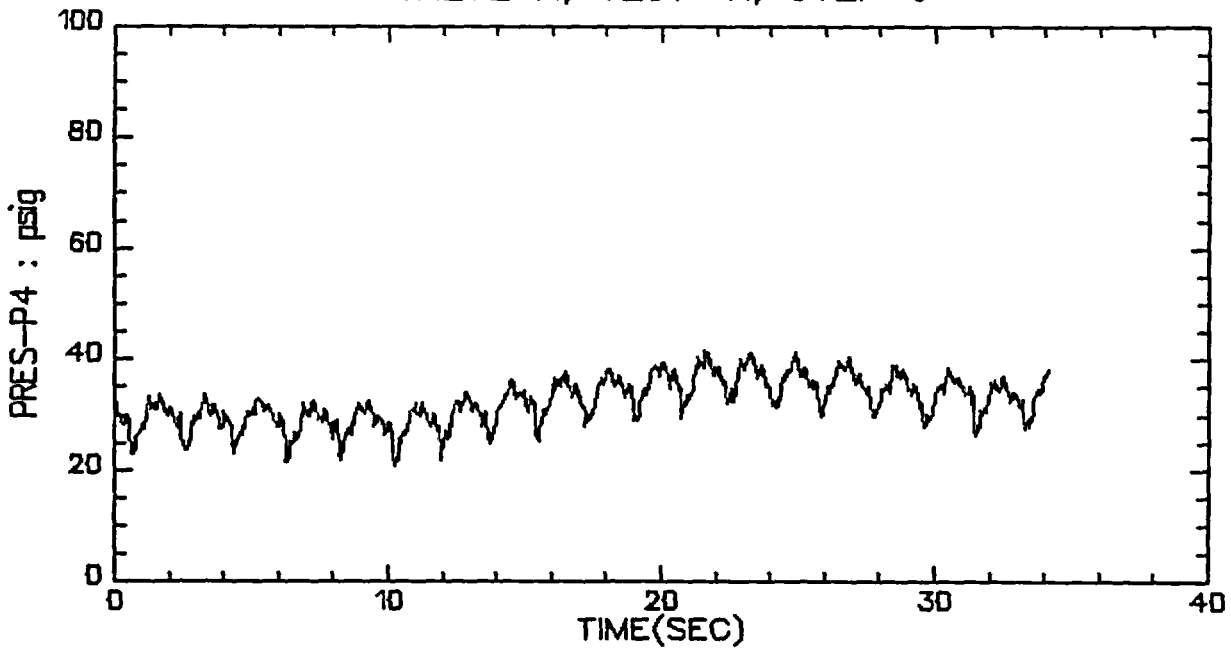

VALVE A, TEST 11, STEP 9

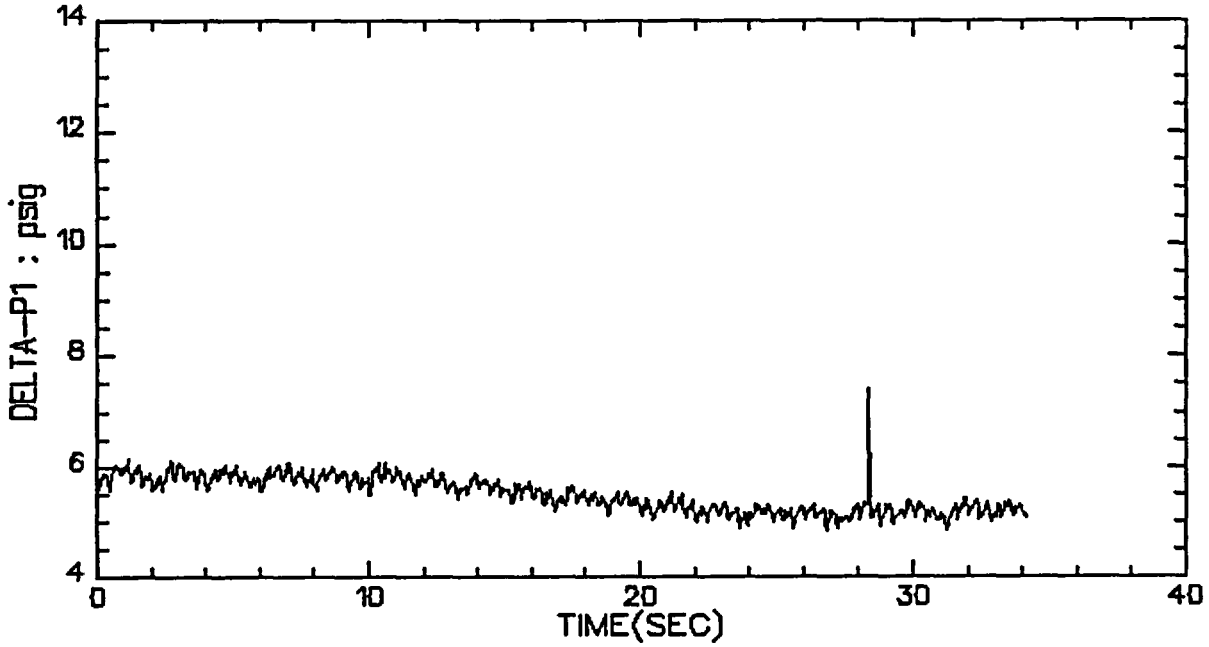

VALVE A, TEST 11, STEP 9

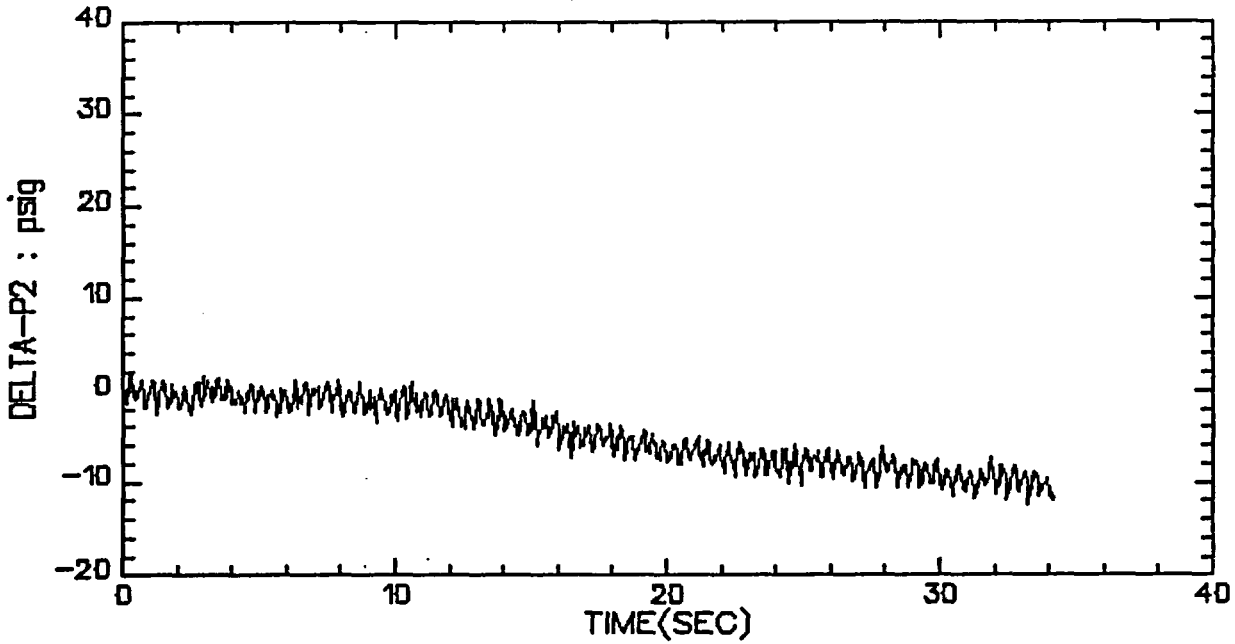

VALVE A, TEST 11, STEP 9

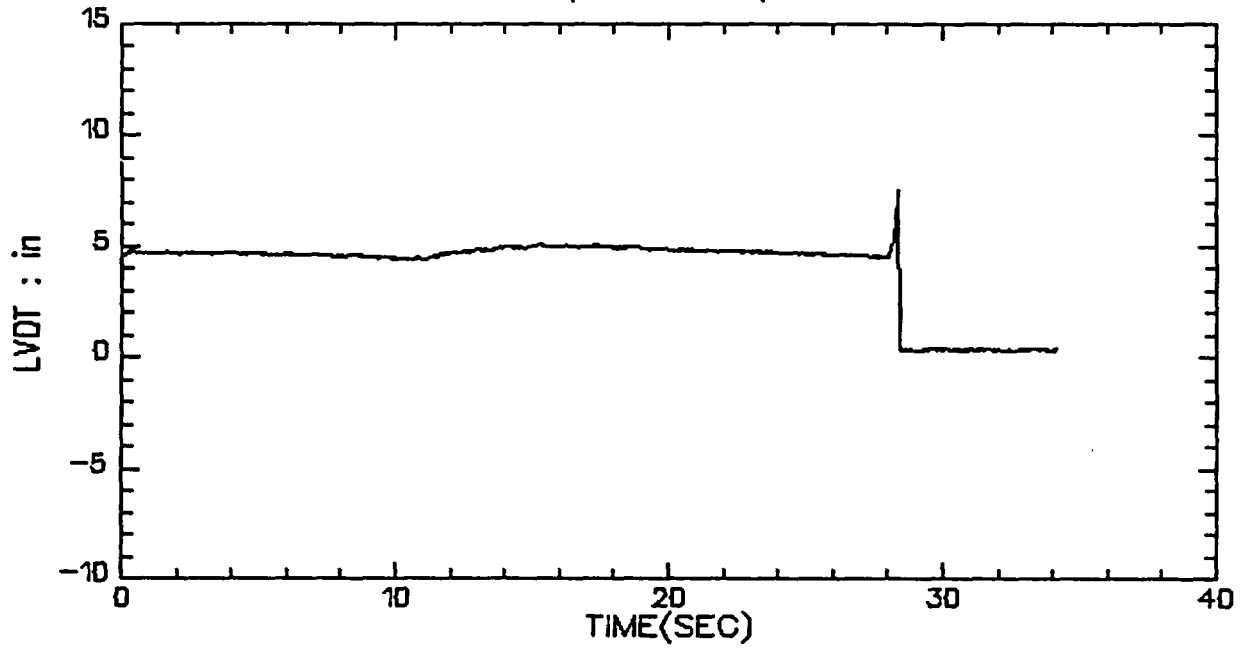

VALVE A, TEST 11, STEP 9

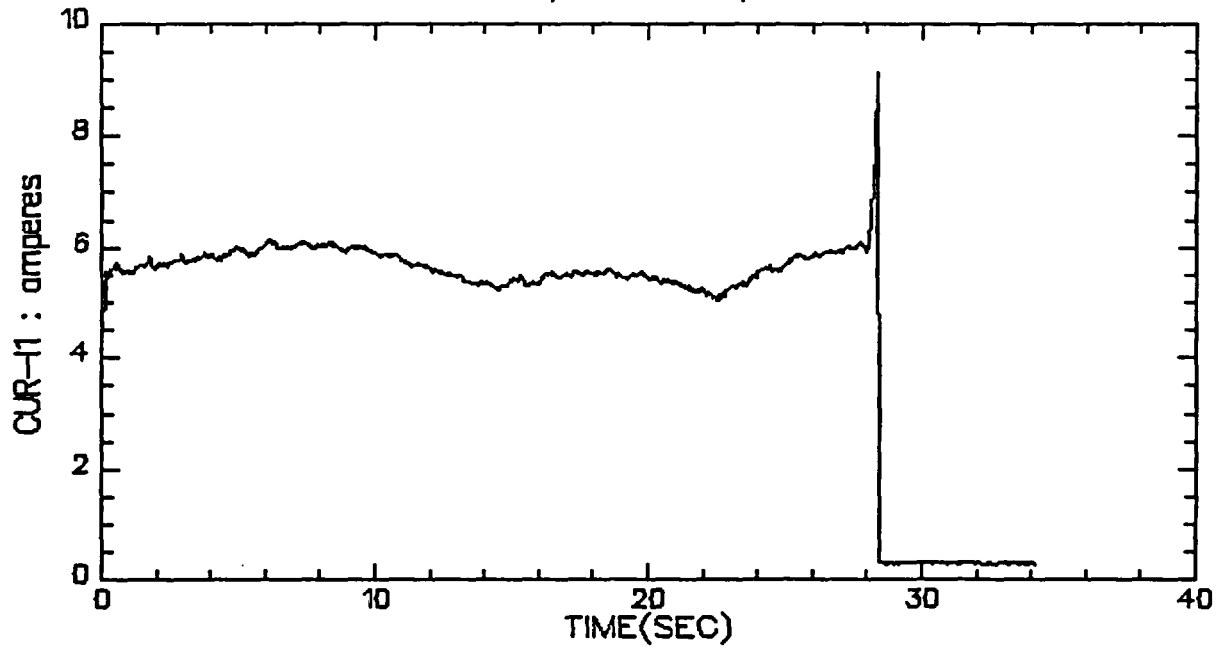

VALVE A, TEST 11, STEP 9

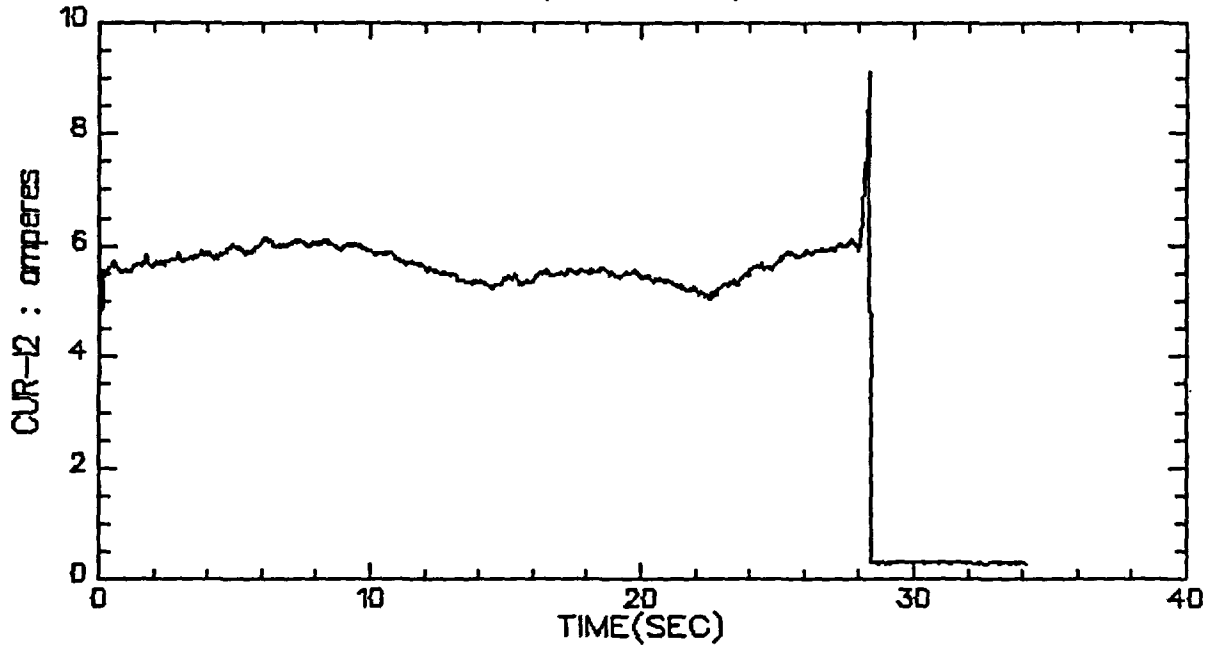

VALVE A, TEST 11, STEP 9

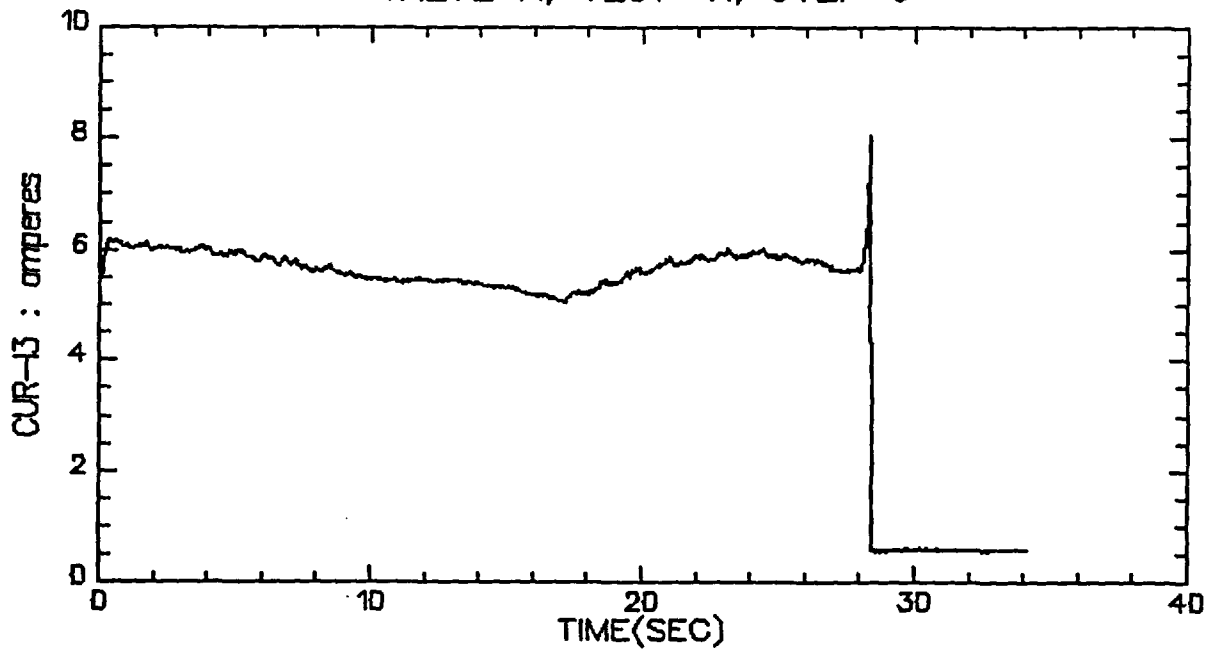

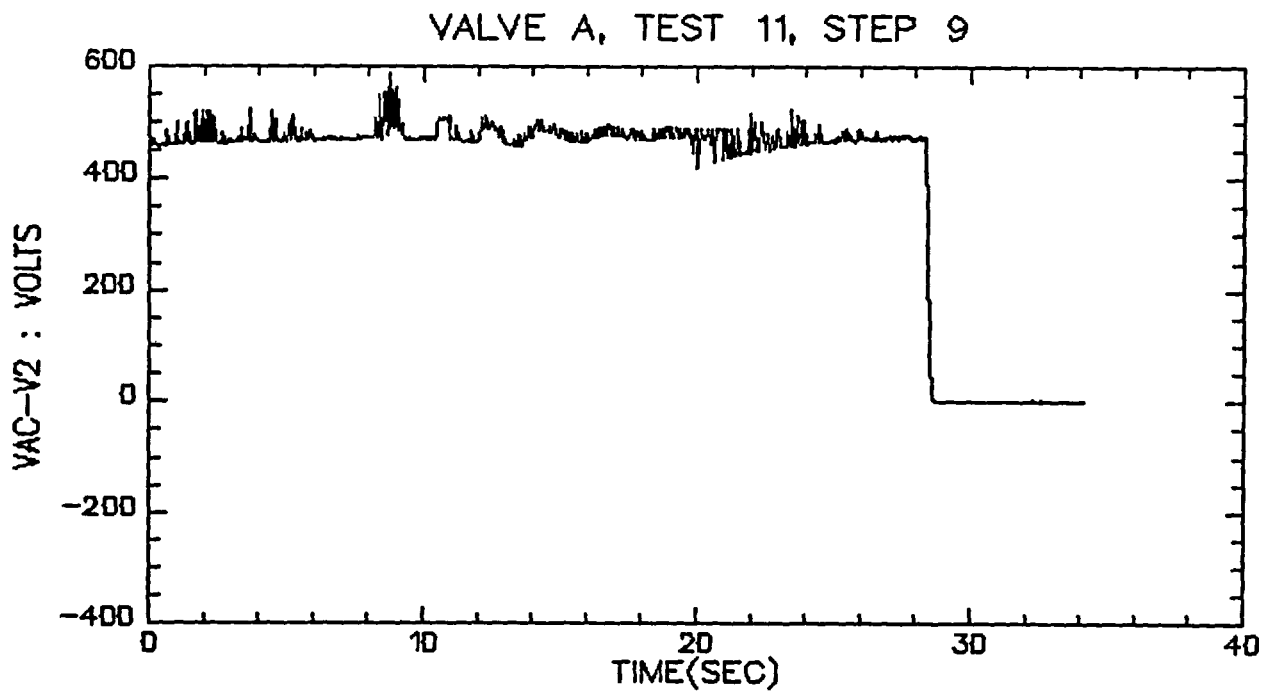
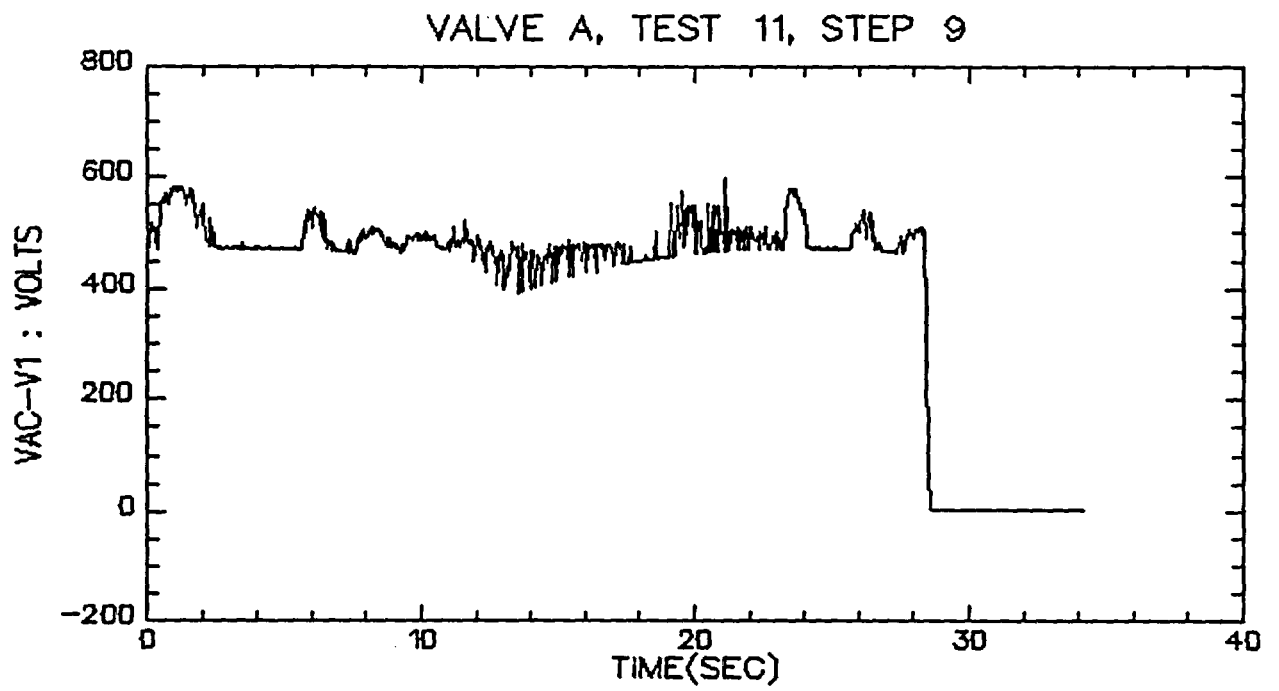

VALVE A, TEST 11, STEP 9

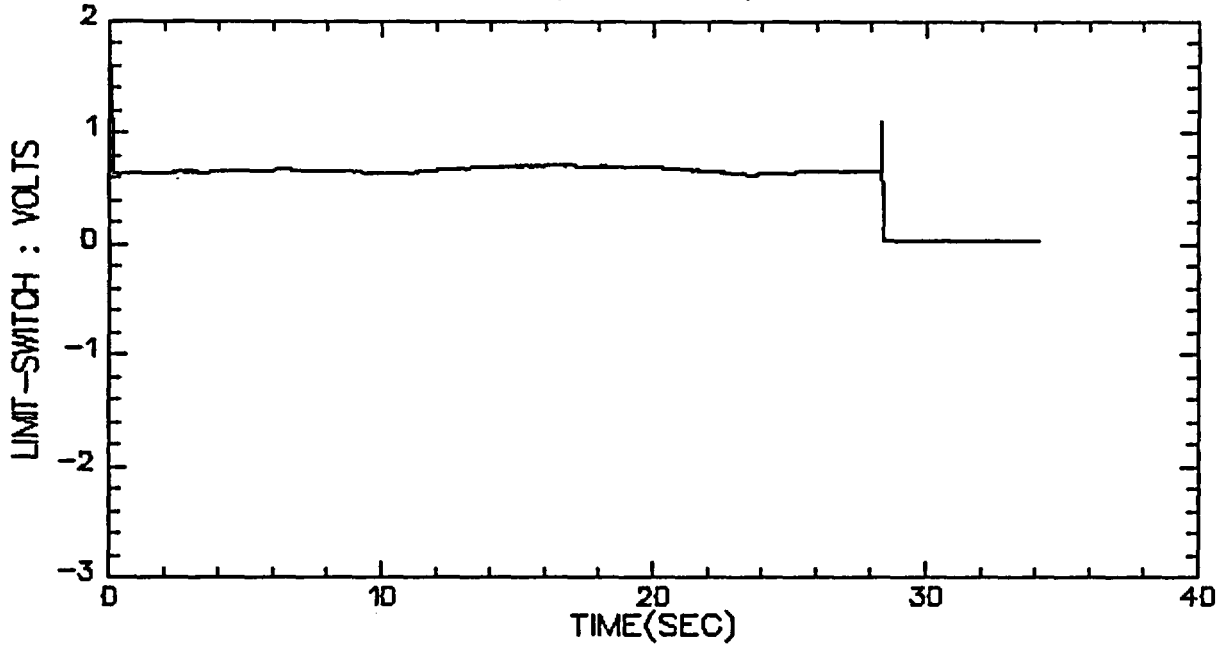

VALVE A, TEST 11, STEP 9

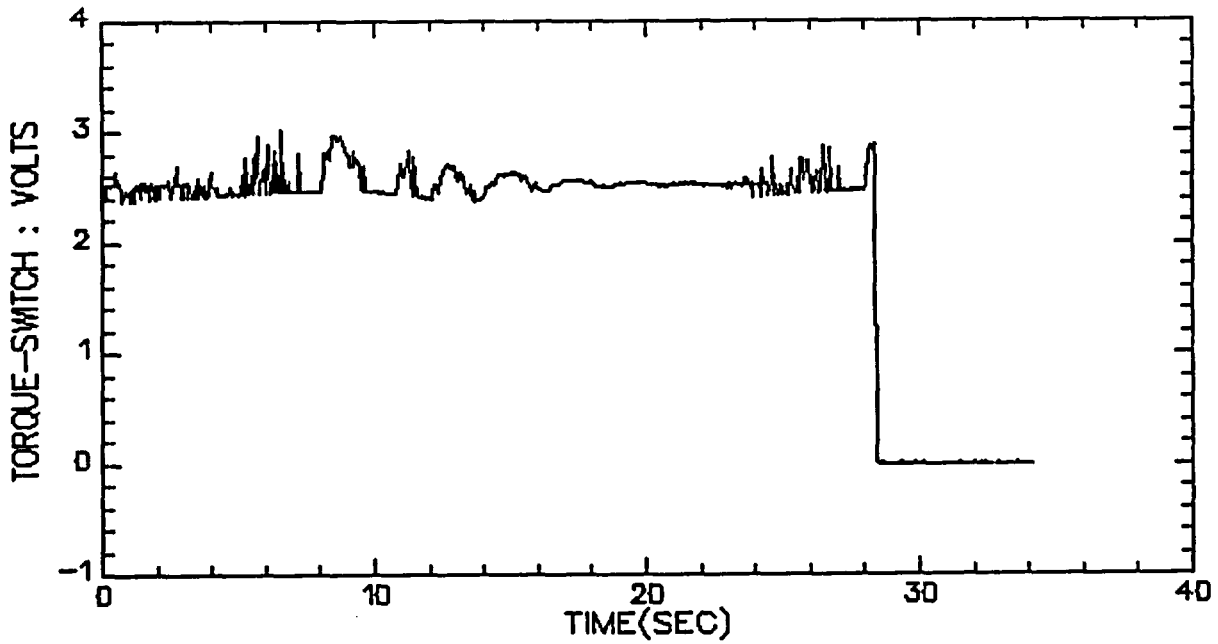

VALVE A, TEST 11, STEP 9

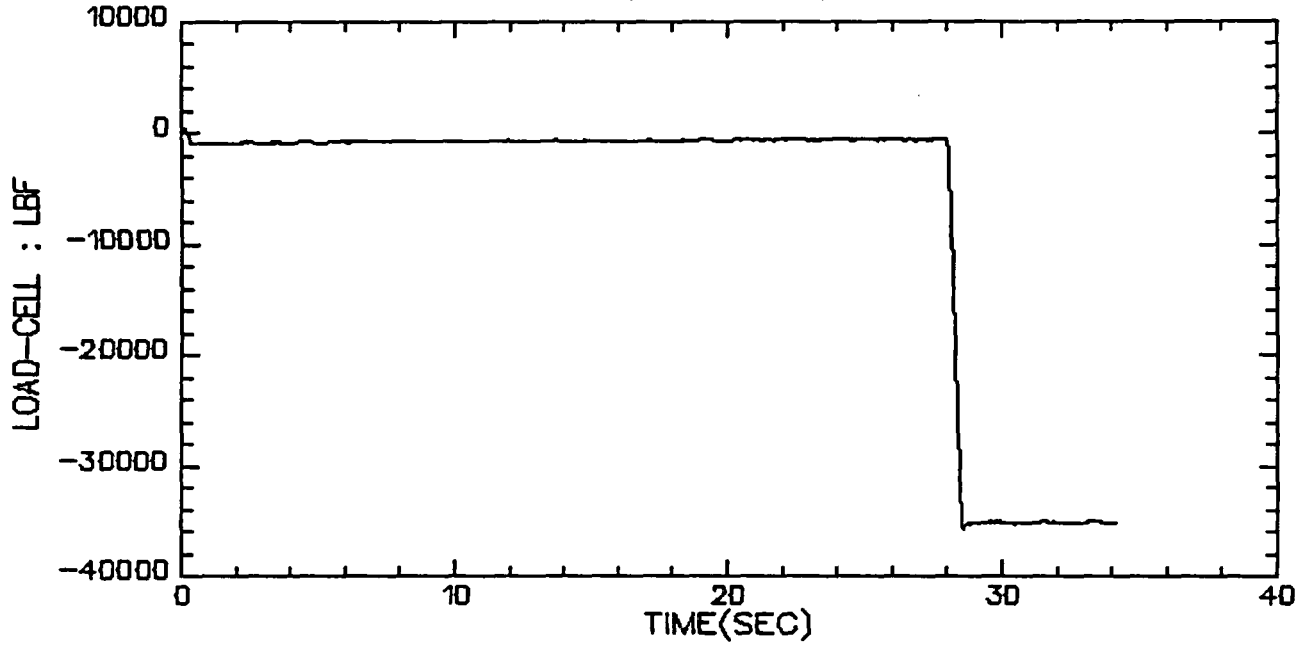

VALVE A, TEST 11, STEP 17

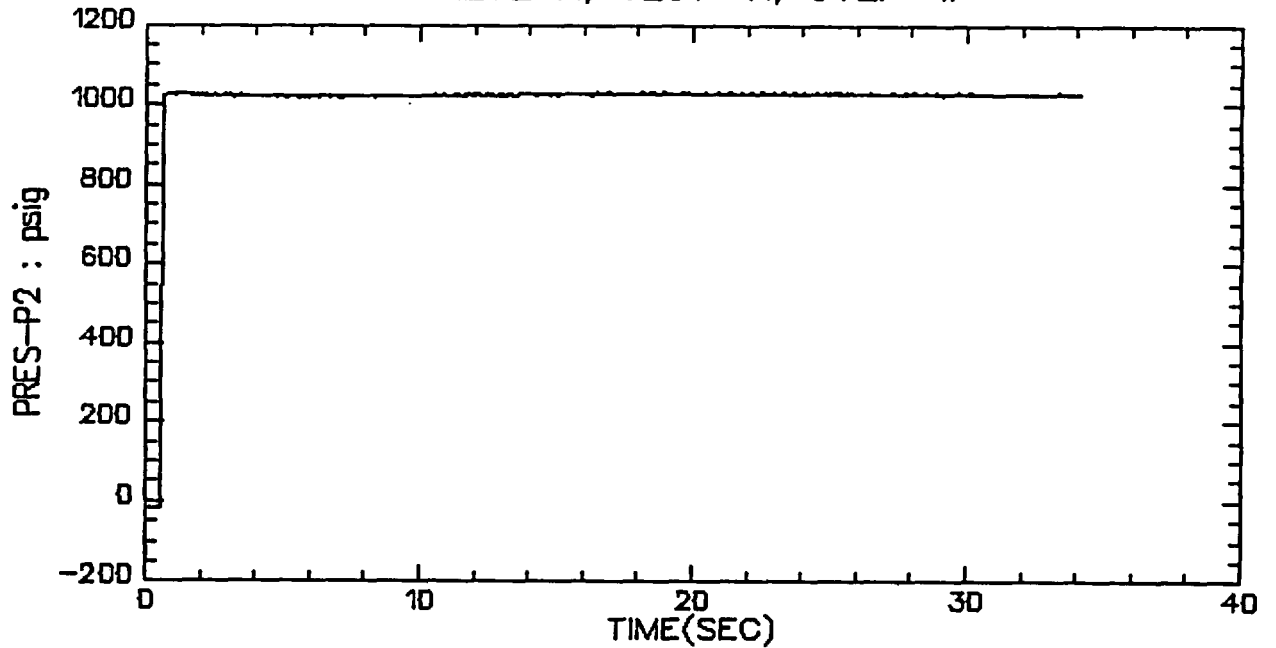

VALVE A, TEST 11, STEP 17

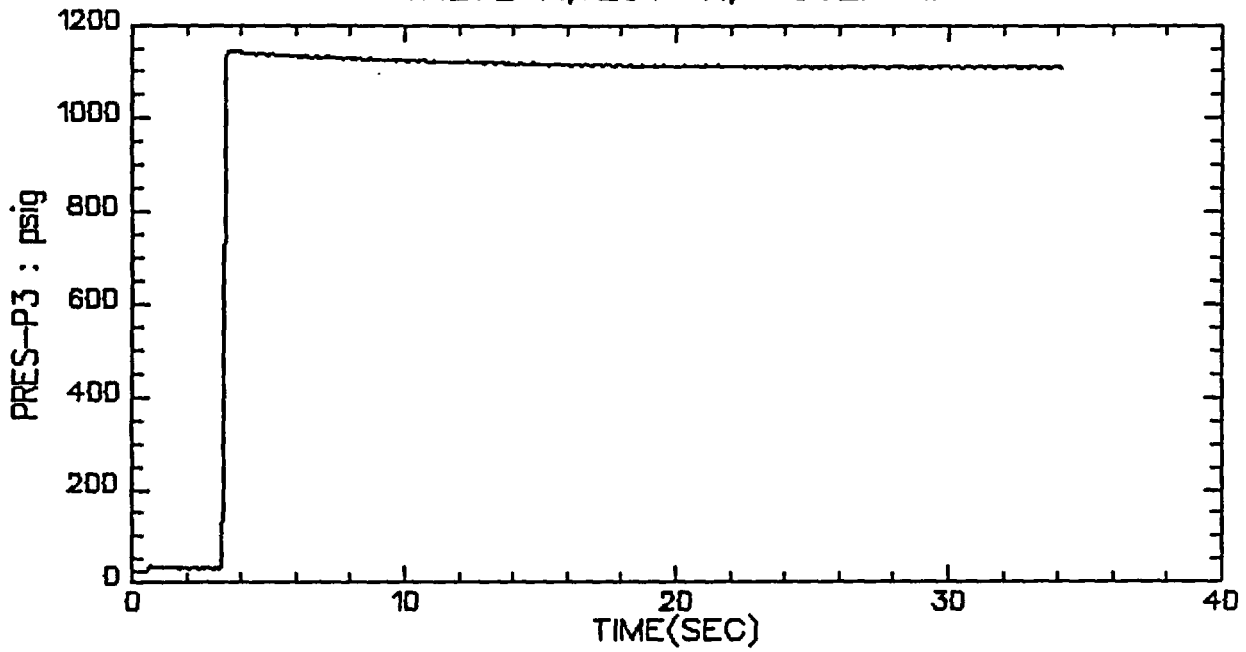

VALVE A, TEST 11, STEP 17

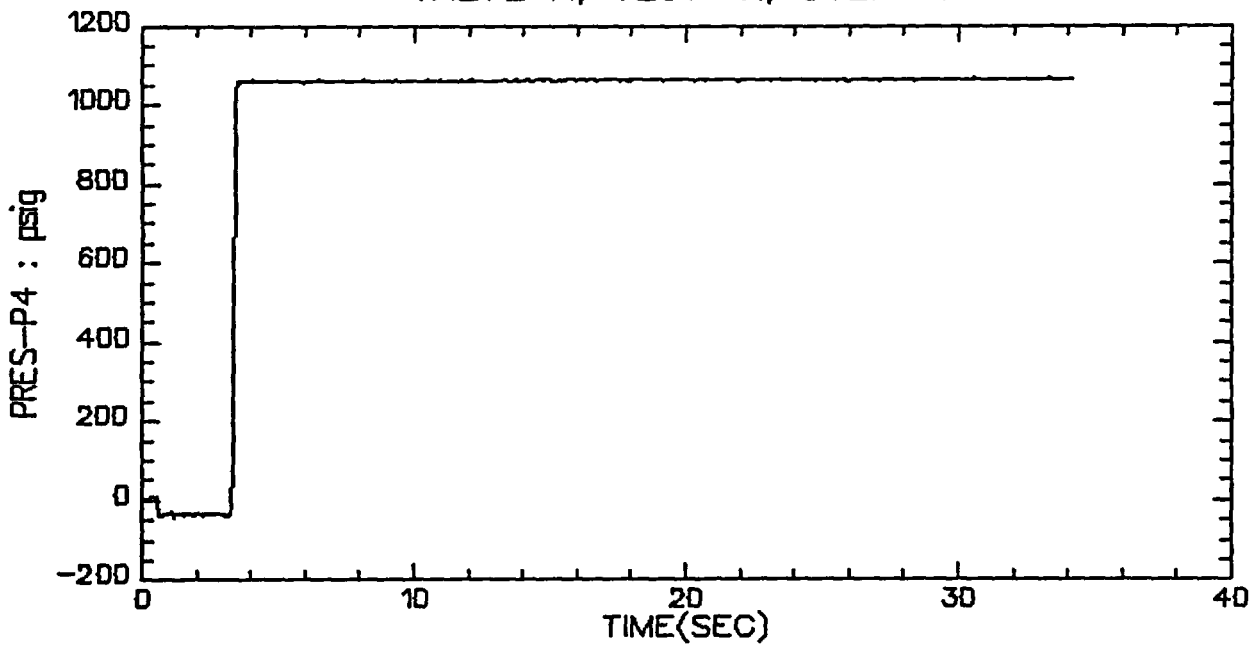

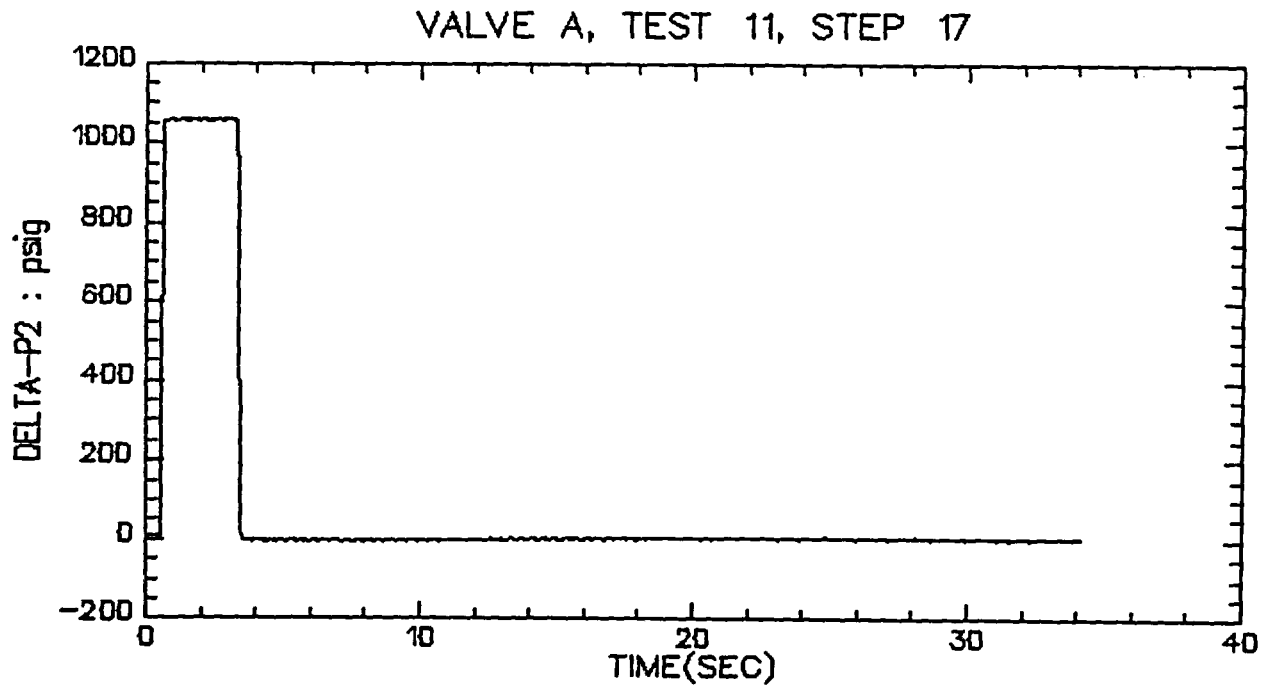
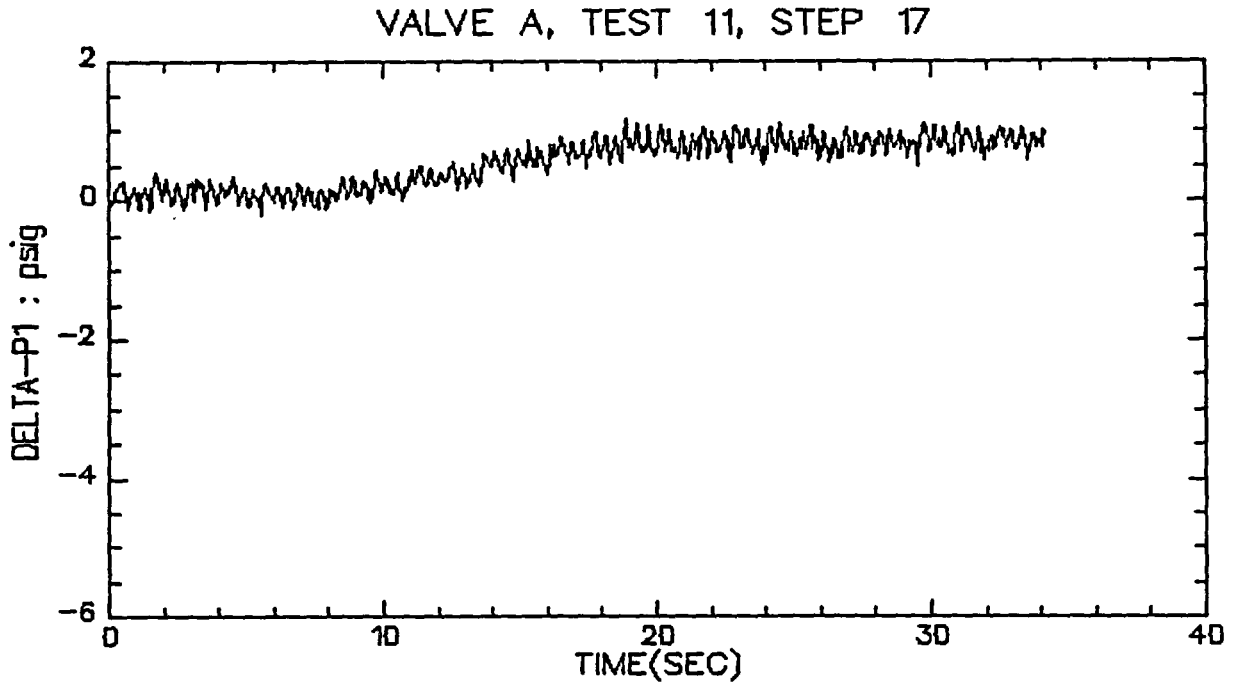

VALVE A, TEST 11, STEP 17

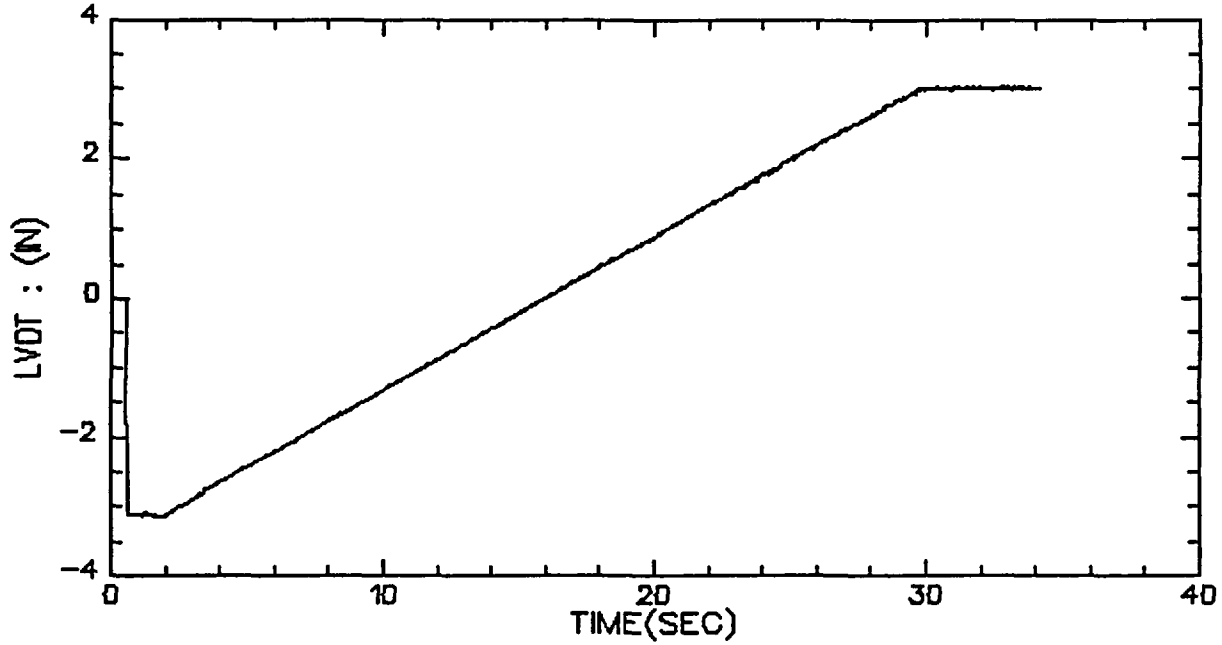

VALVE A, TEST 11, STEP 17

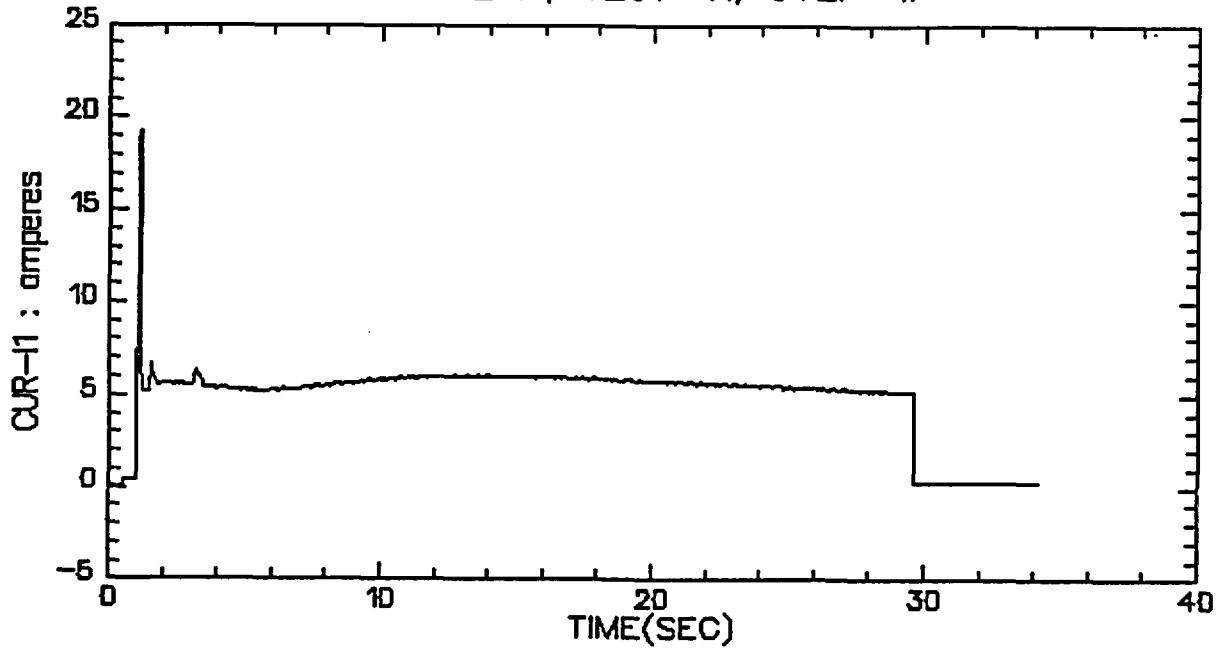

VALVE A, TEST 11, STEP 17

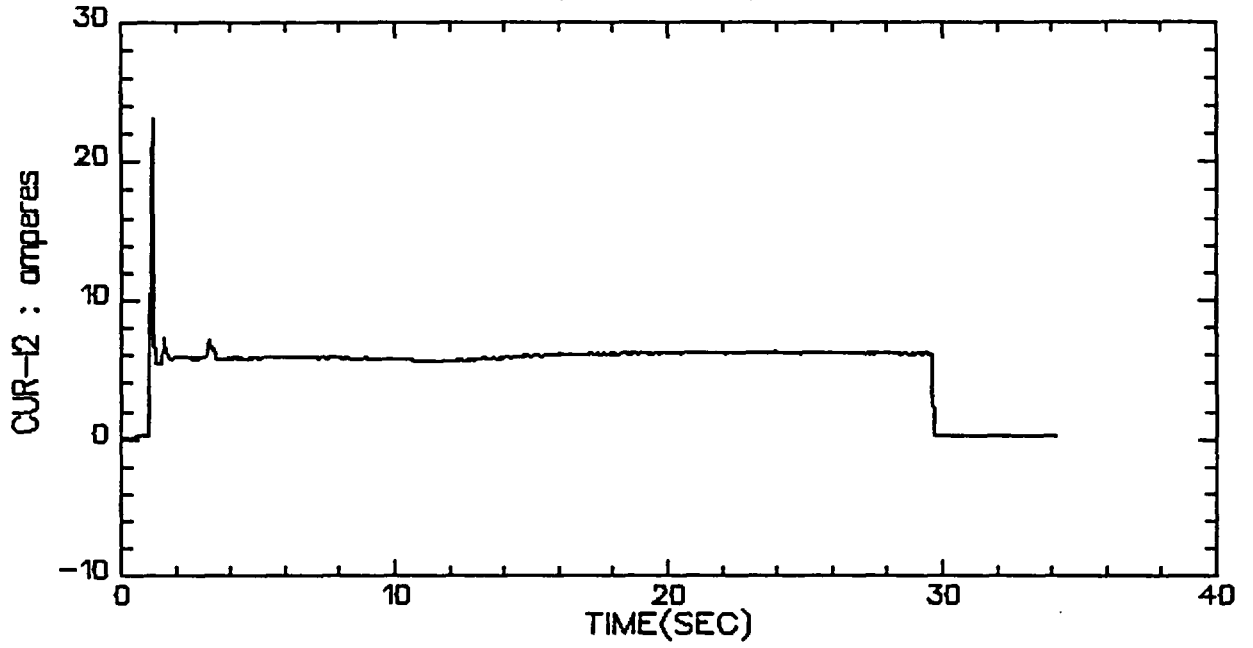

VALVE A, TEST 11, STEP 17

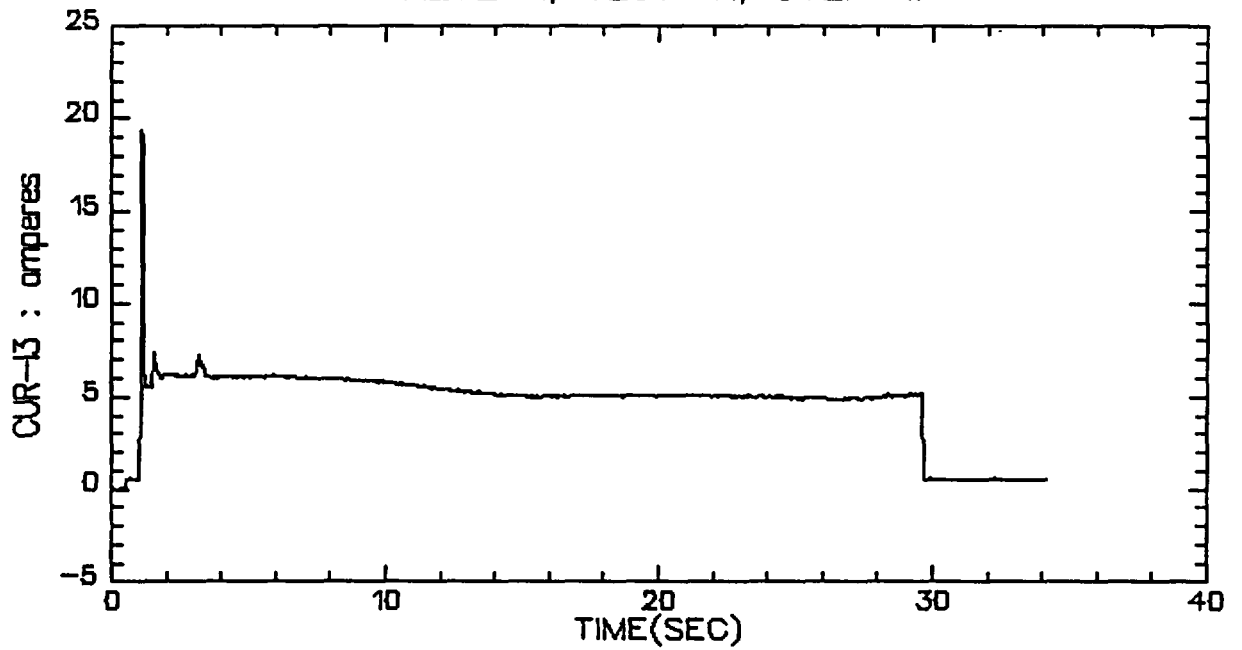

VALVE A, TEST 11, STEP 17

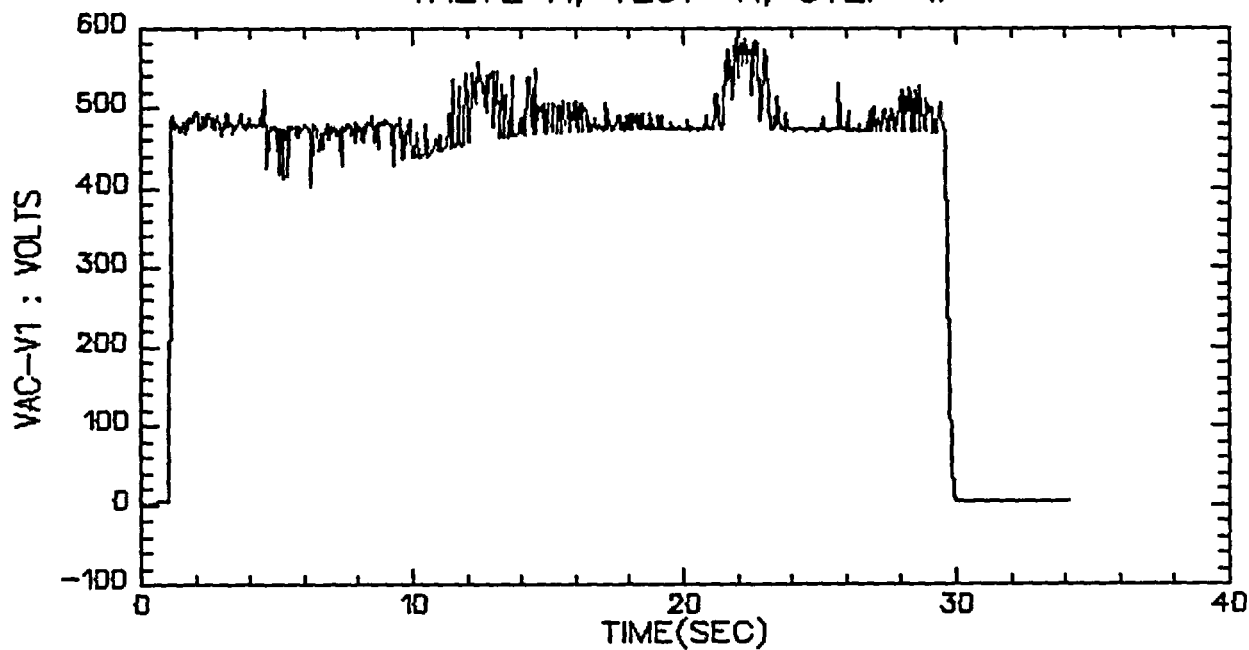

VALVE A, TEST 11, STEP 17

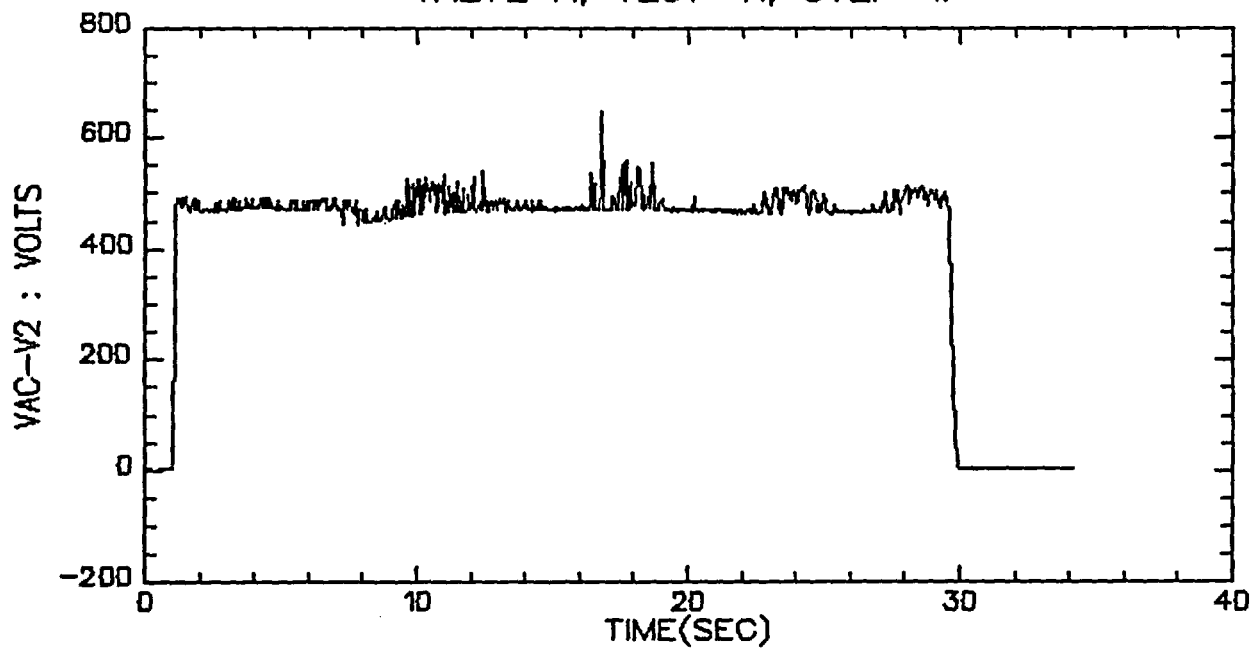

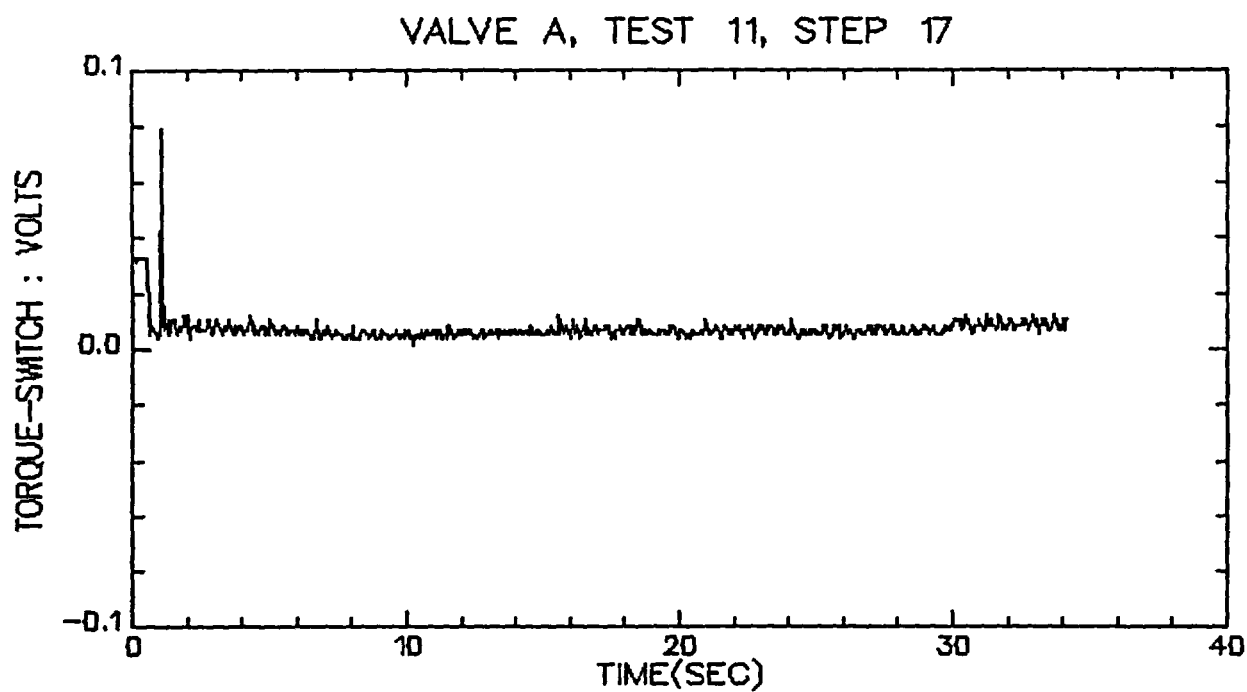
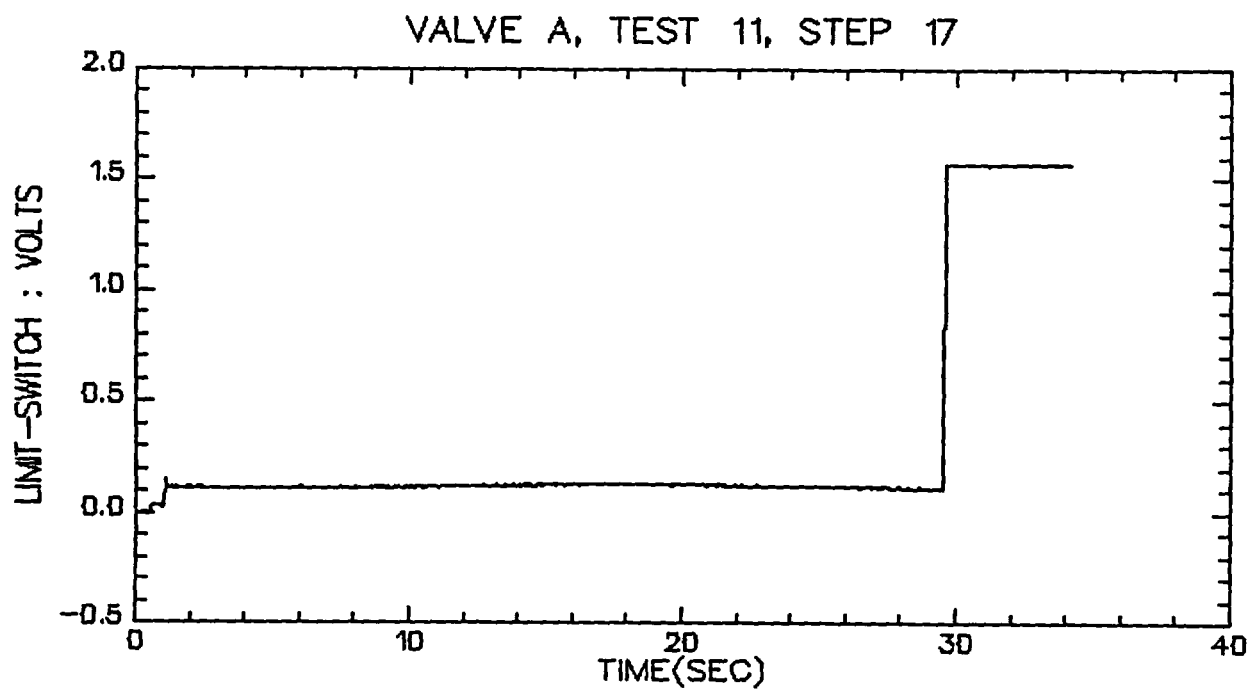

VALVE B, TEST 1, STEP 1

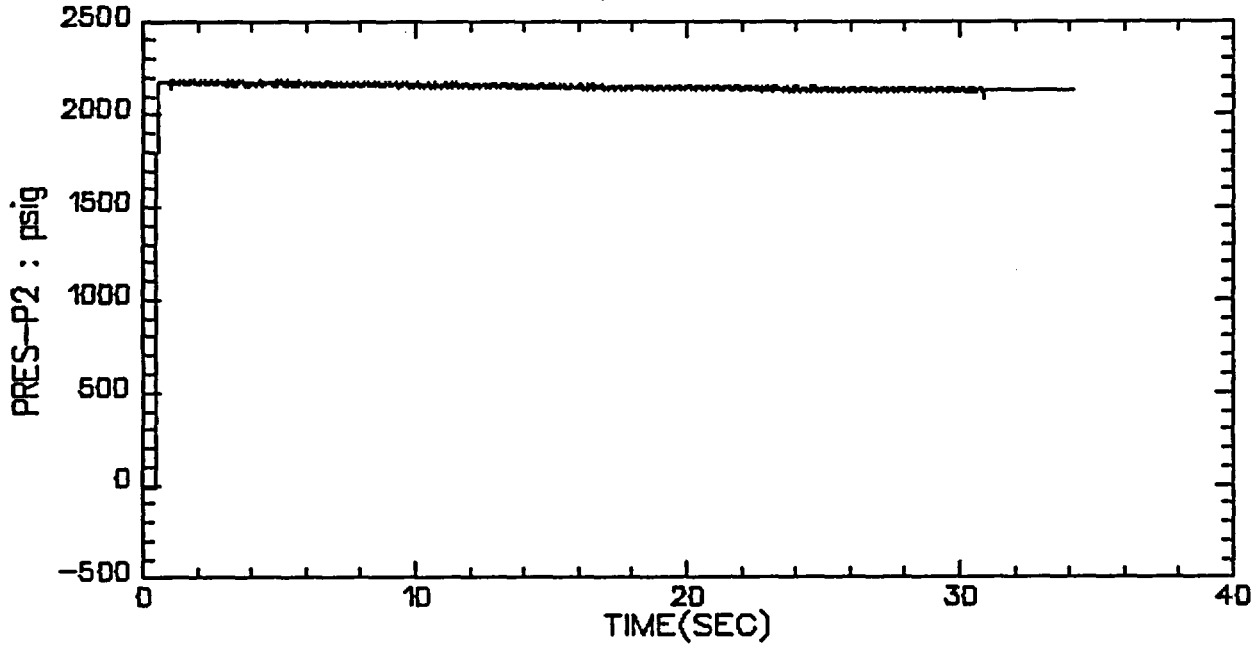

VALVE B, TEST 1, STEP 1

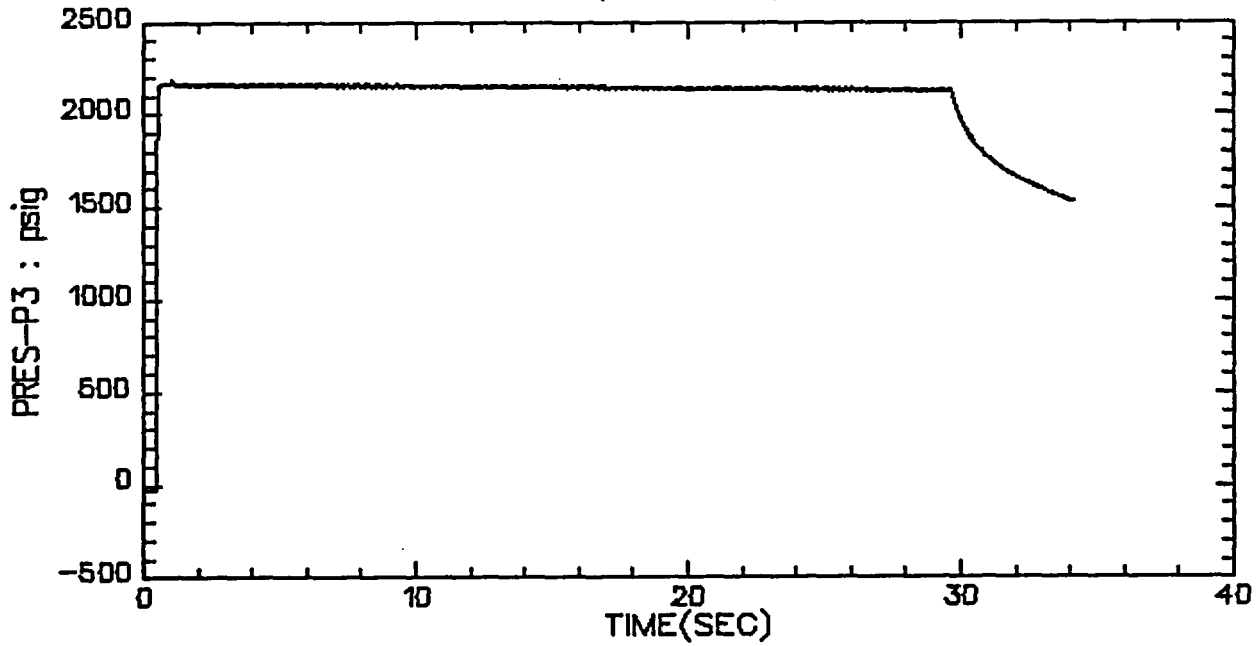

VALVE B, TEST 1, STEP 1

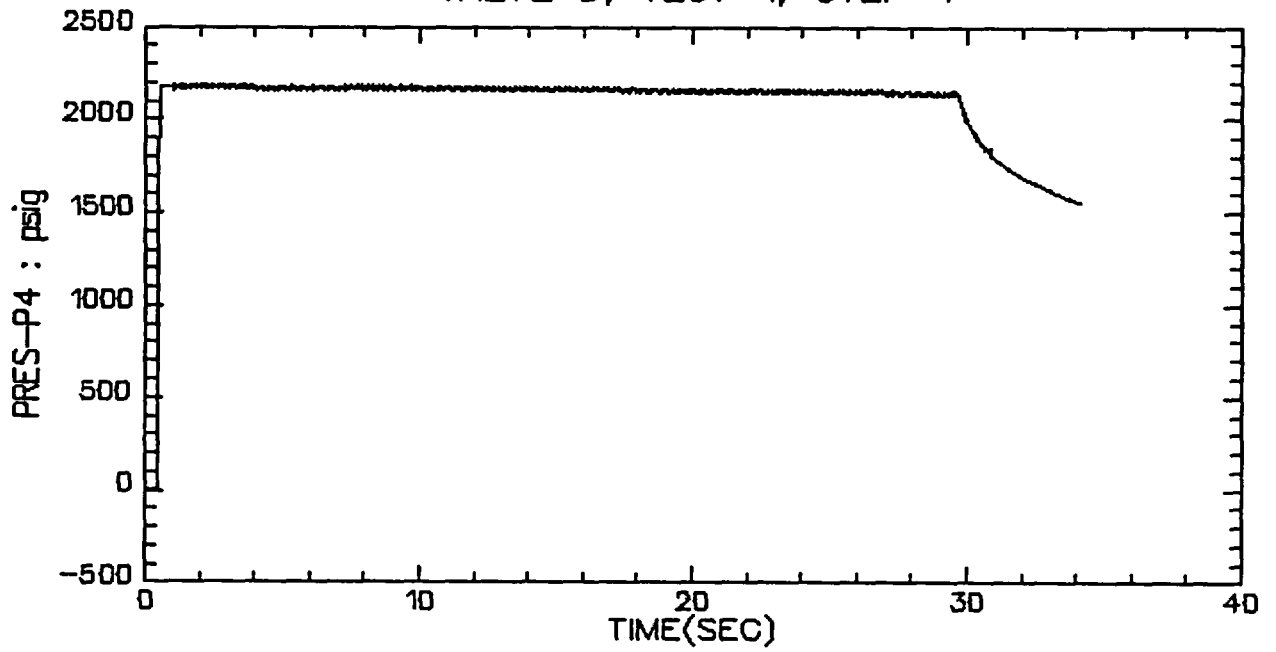

VALVE B, TEST 1, STEP 1

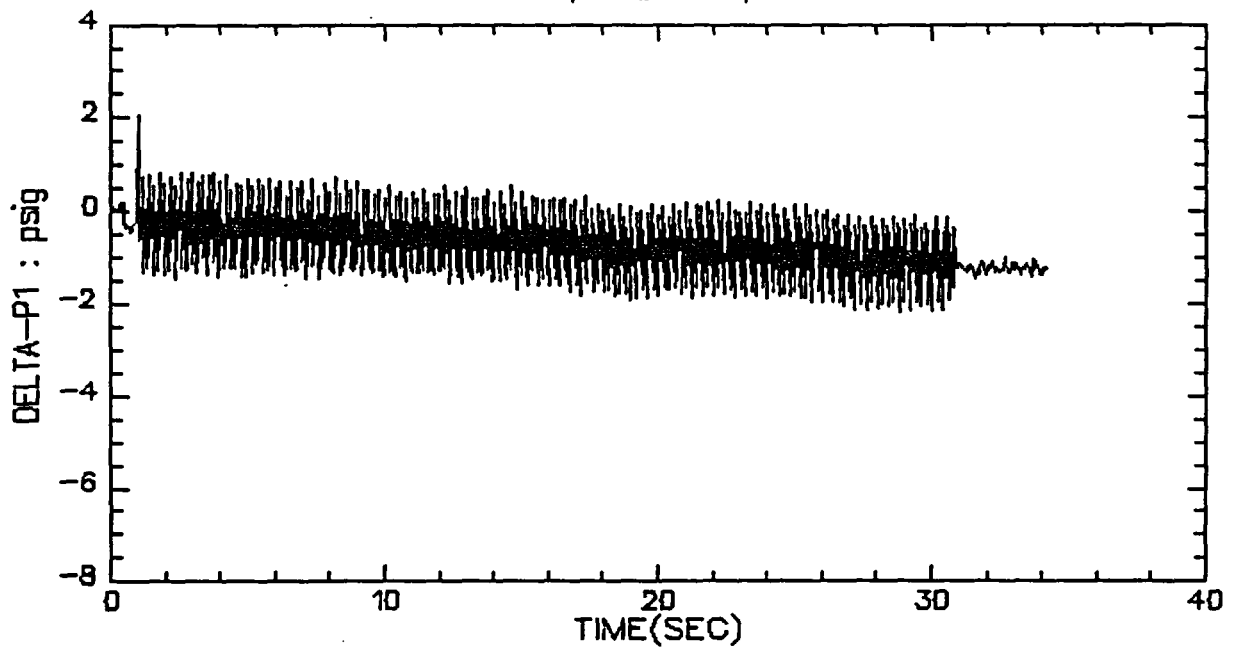

VALVE B, TEST 1, STEP 1

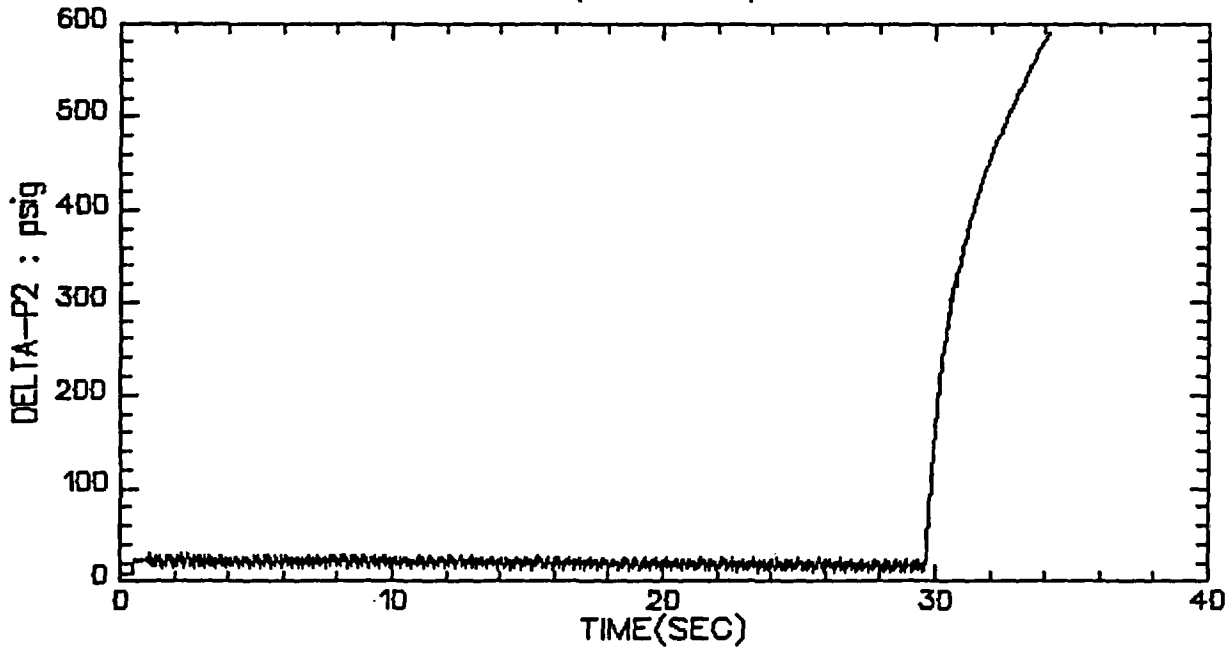

VALVE B, TEST 1, STEP 1

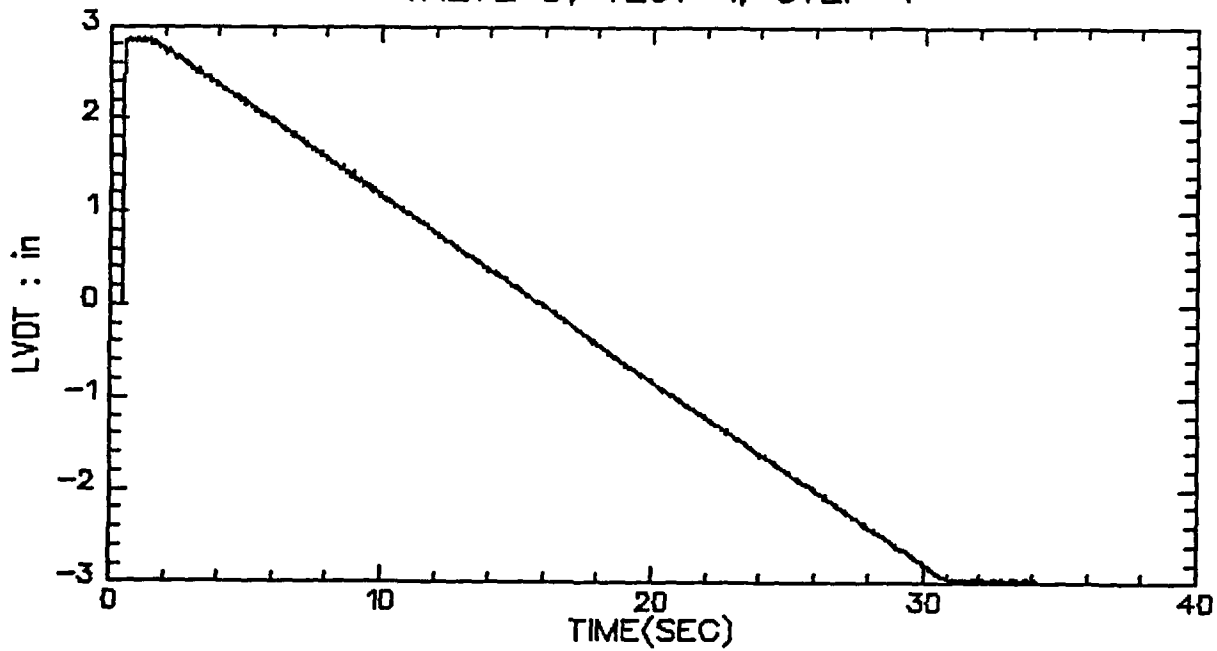

VALVE B, TEST 1, STEP 1

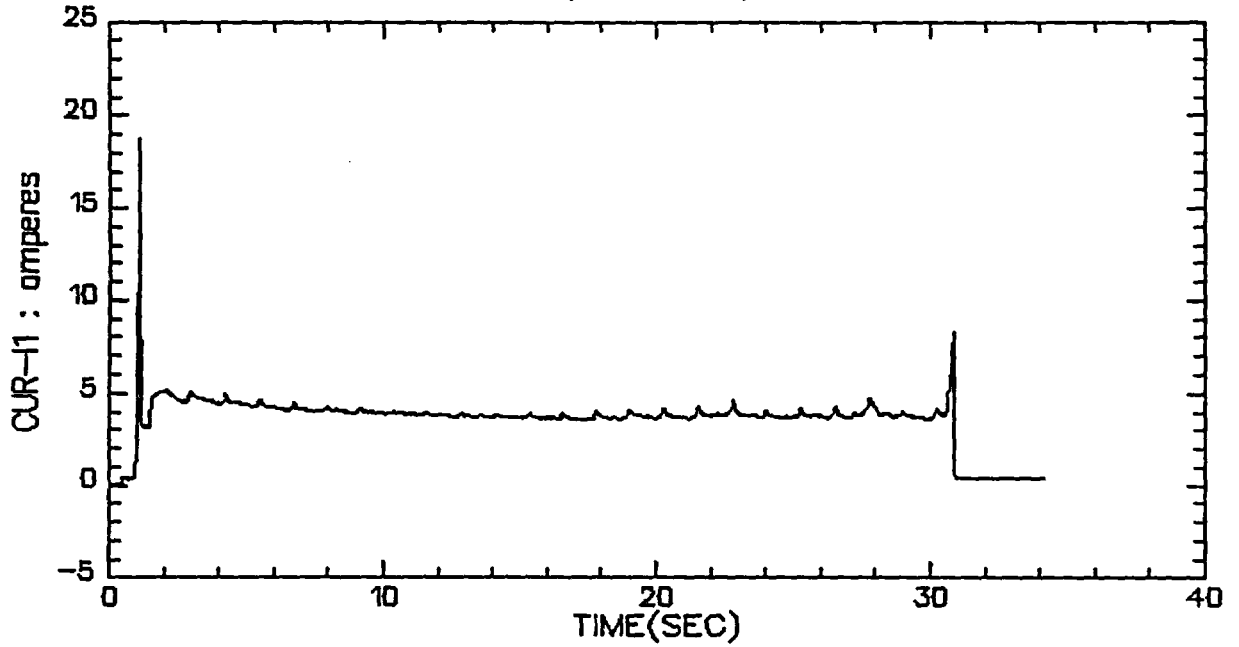

VALVE B, TEST 1, STEP 1

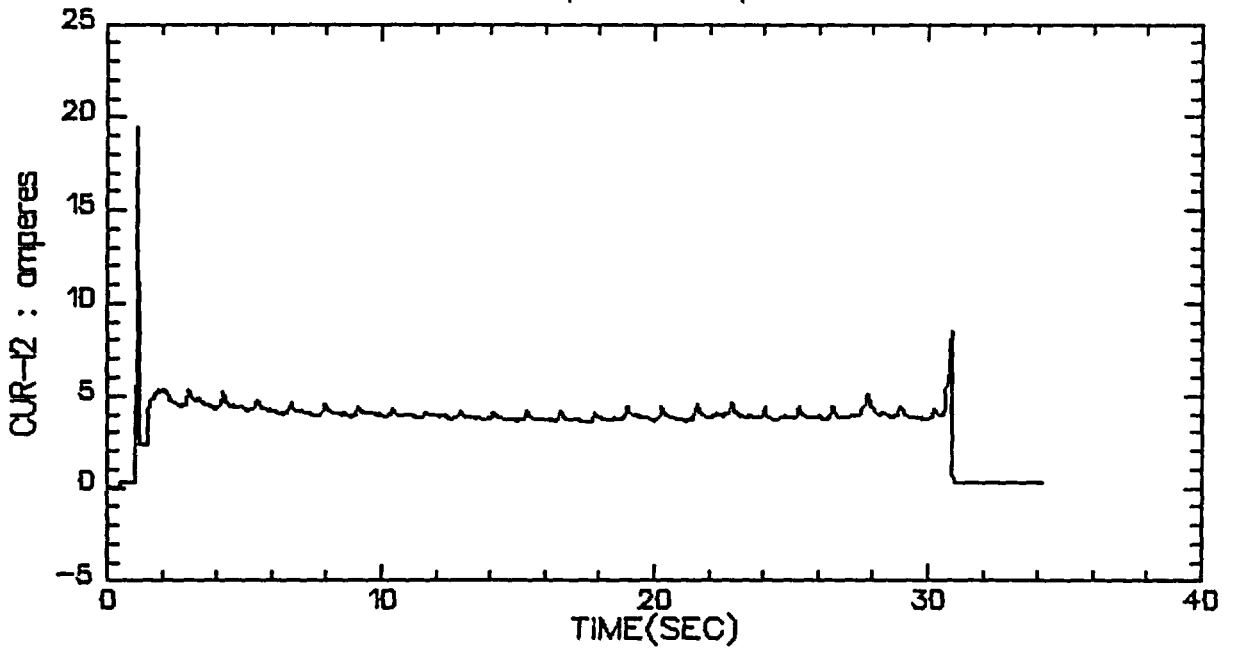

VALVE B, TEST 1, STEP 1

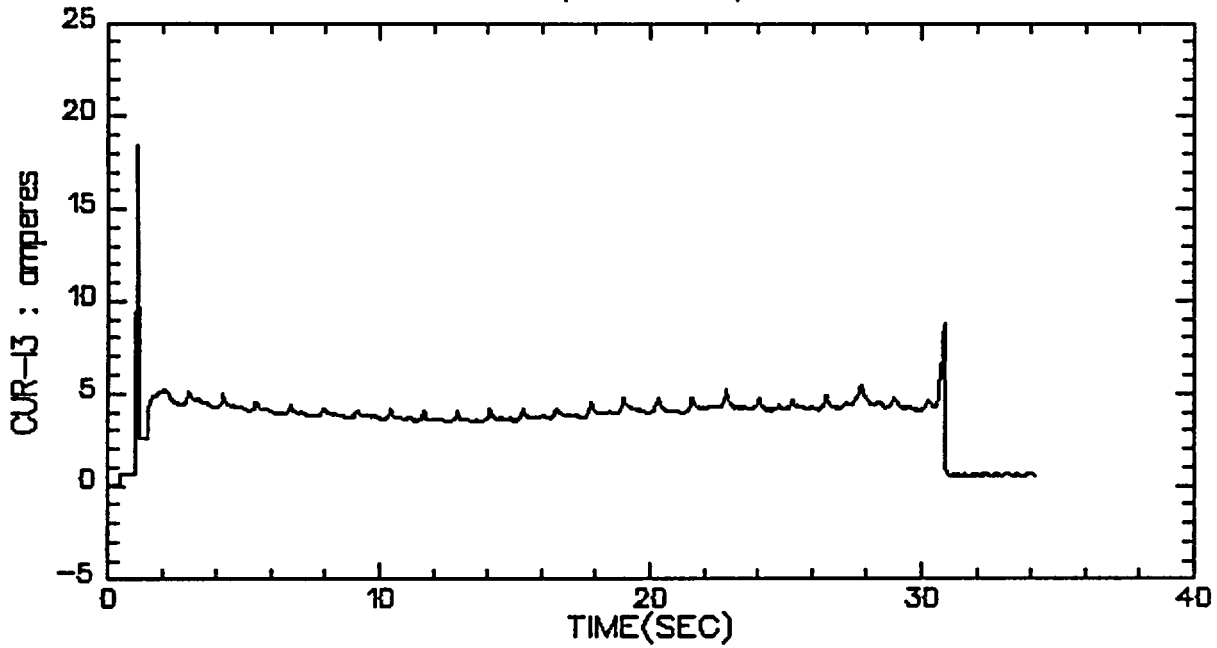

VALVE B, TEST 1, STEP 1

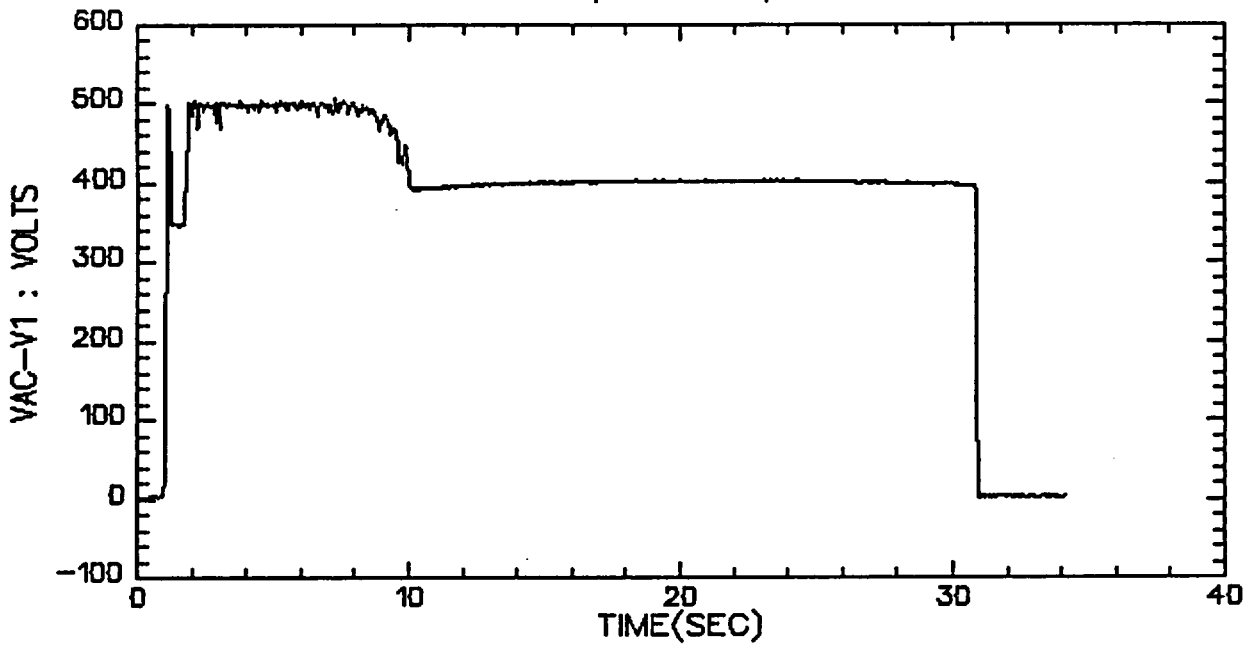

VALVE B, TEST 1, STEP 1

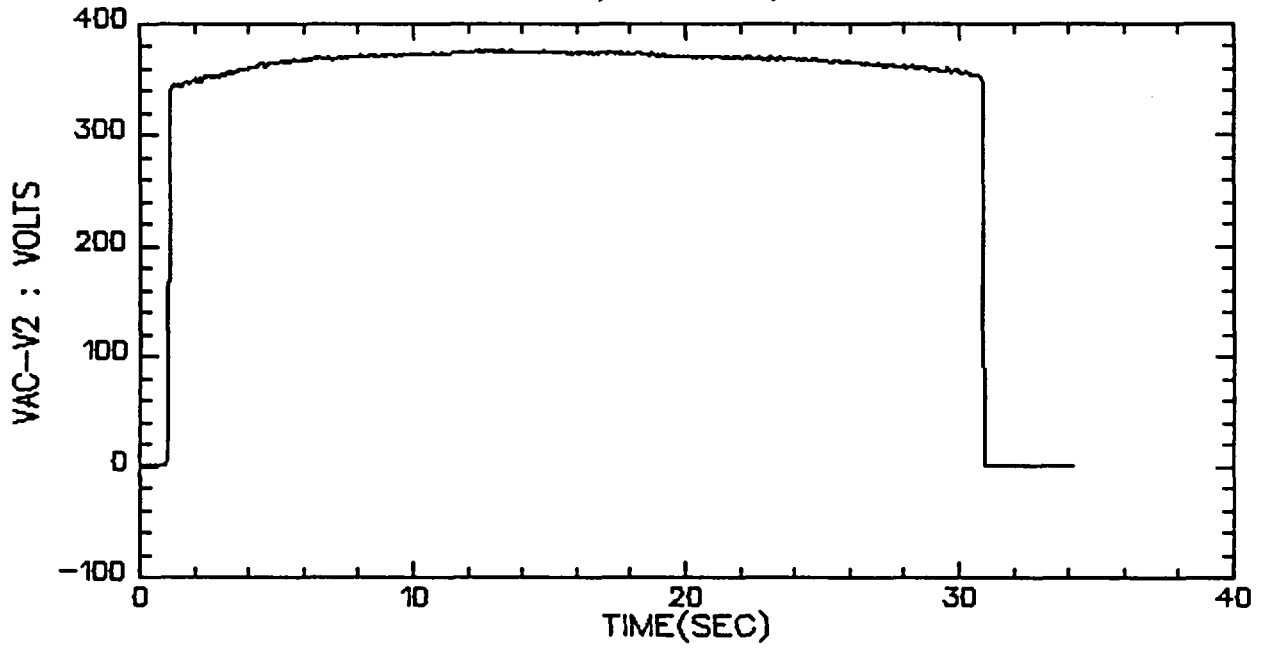

VALVE B, TEST 1, STEP 1

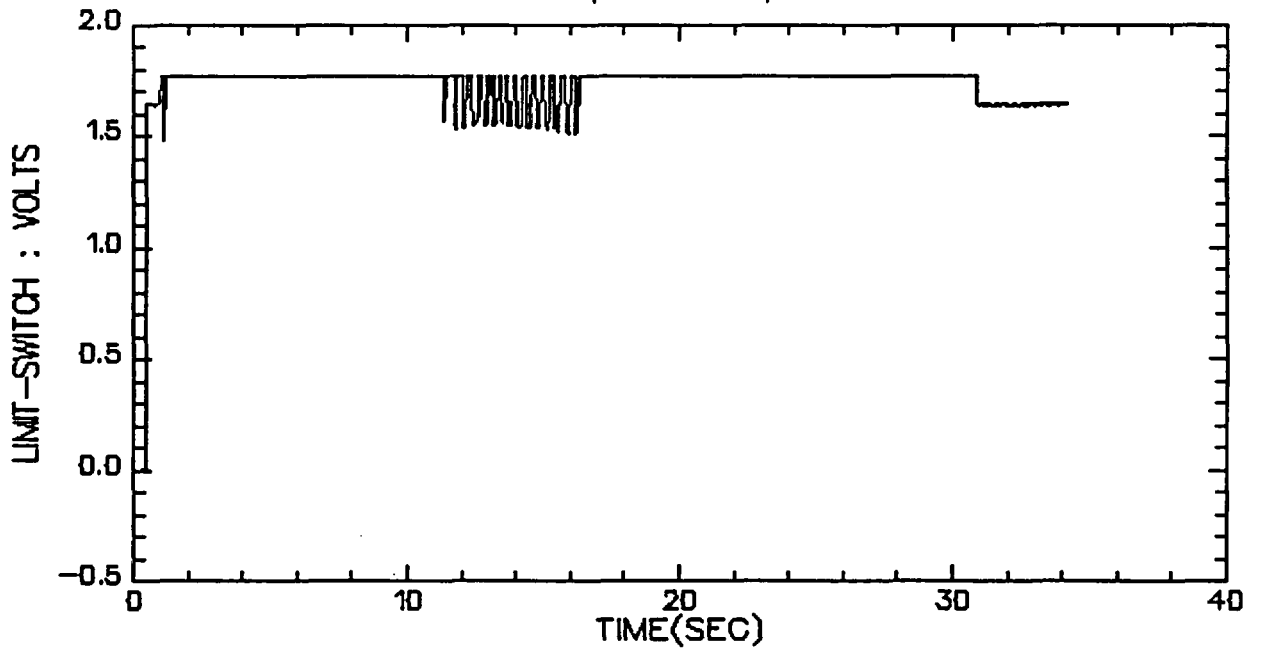

VALVE B, TEST 1, STEP 1

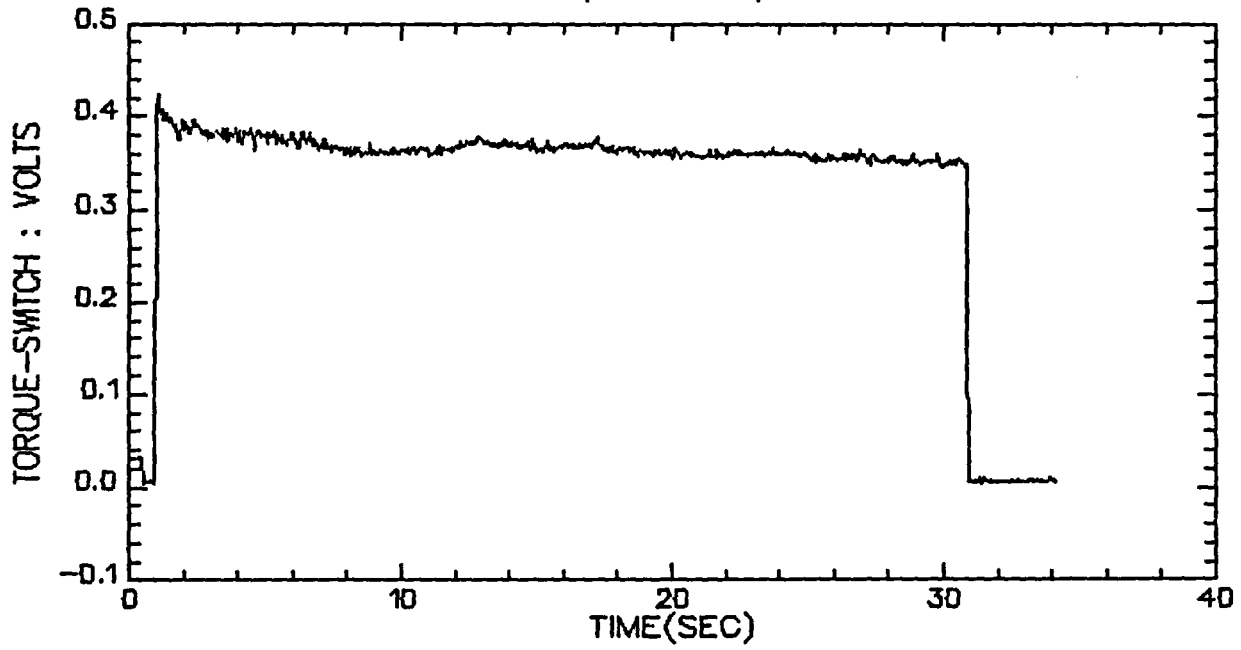

VALVE B, TEST 1, STEP 1

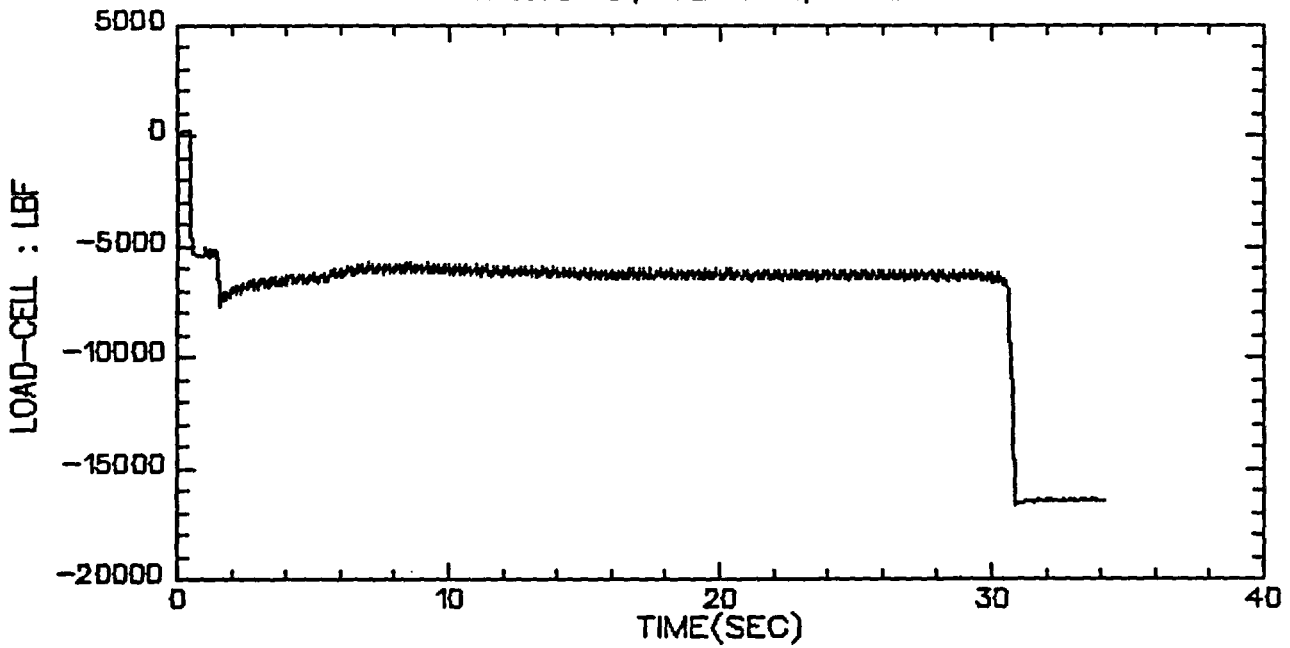

VALVE B, TEST 1, STEP 3

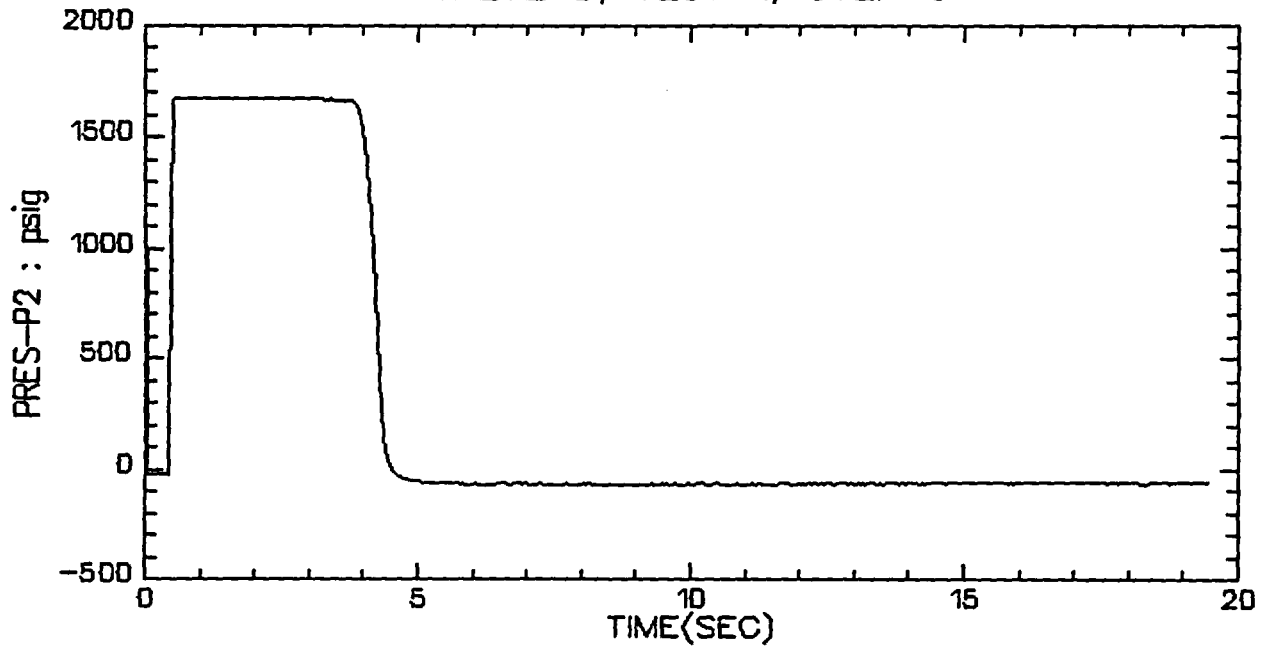

VALVE B, TEST 1, STEP 3

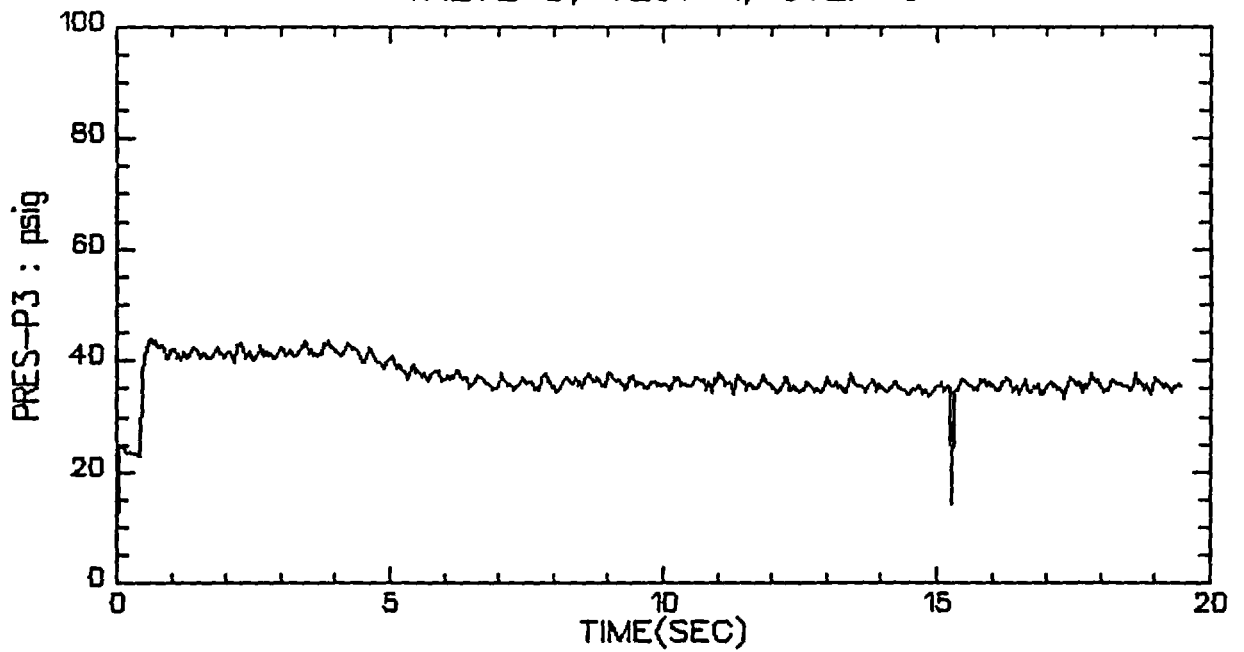

VALVE B, TEST 1, STEP 3

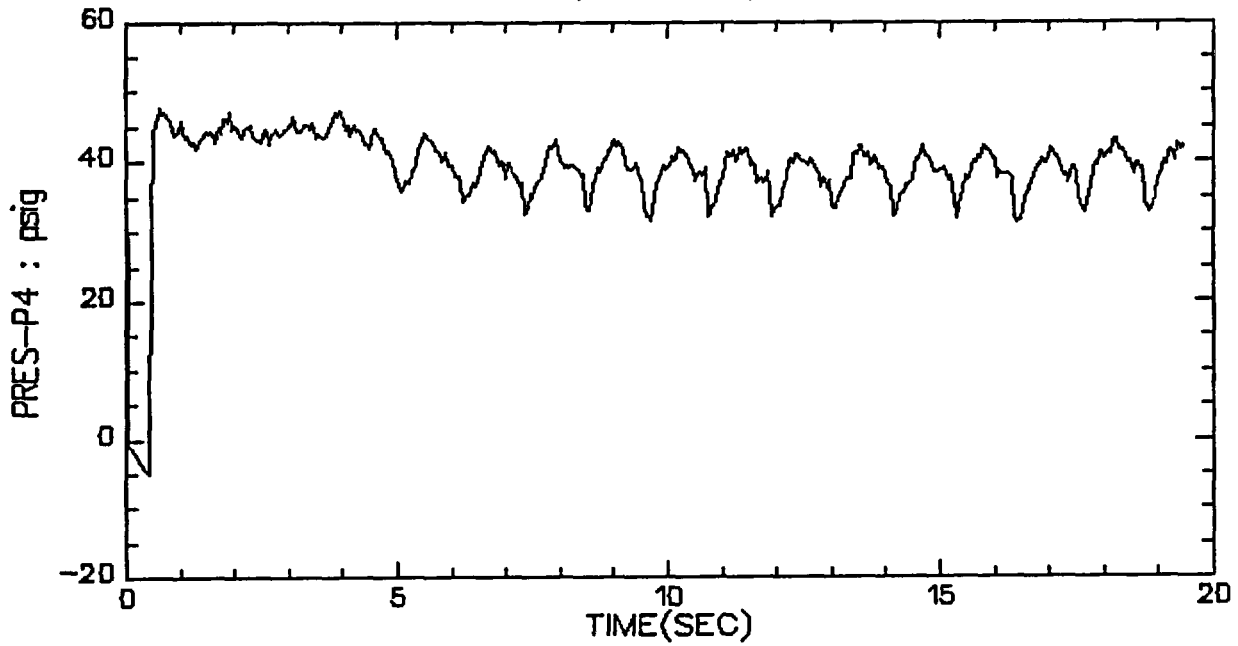

VALVE B, TEST 1, STEP 3

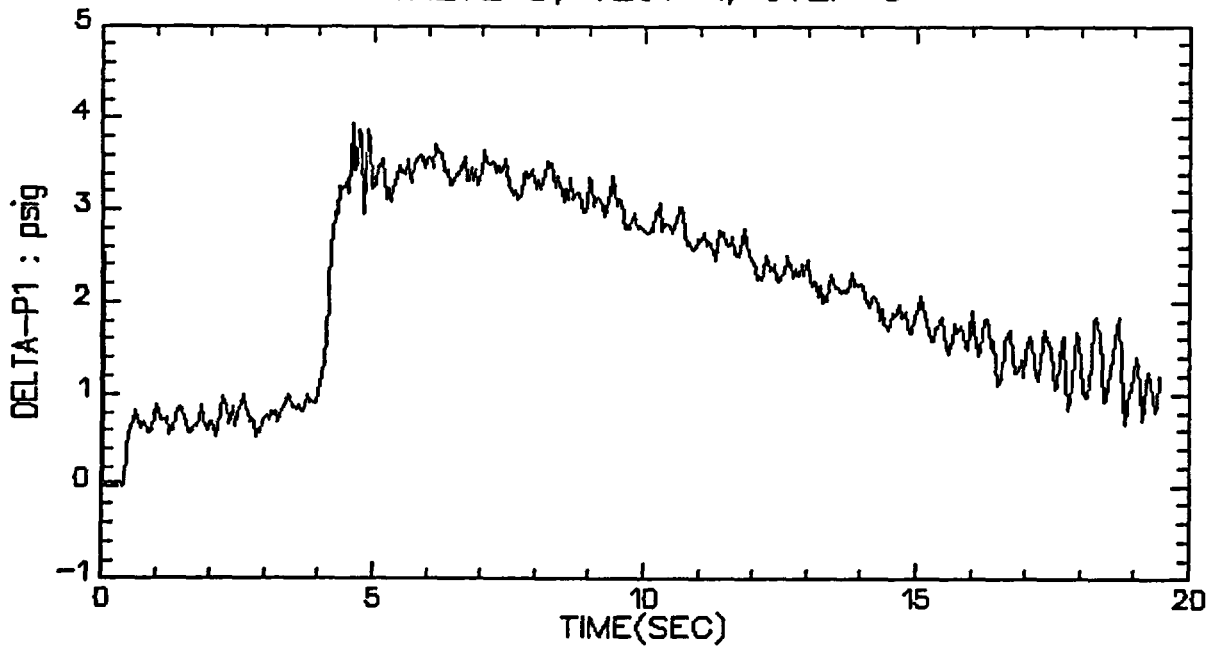

VALVE B, TEST 1, STEP 3

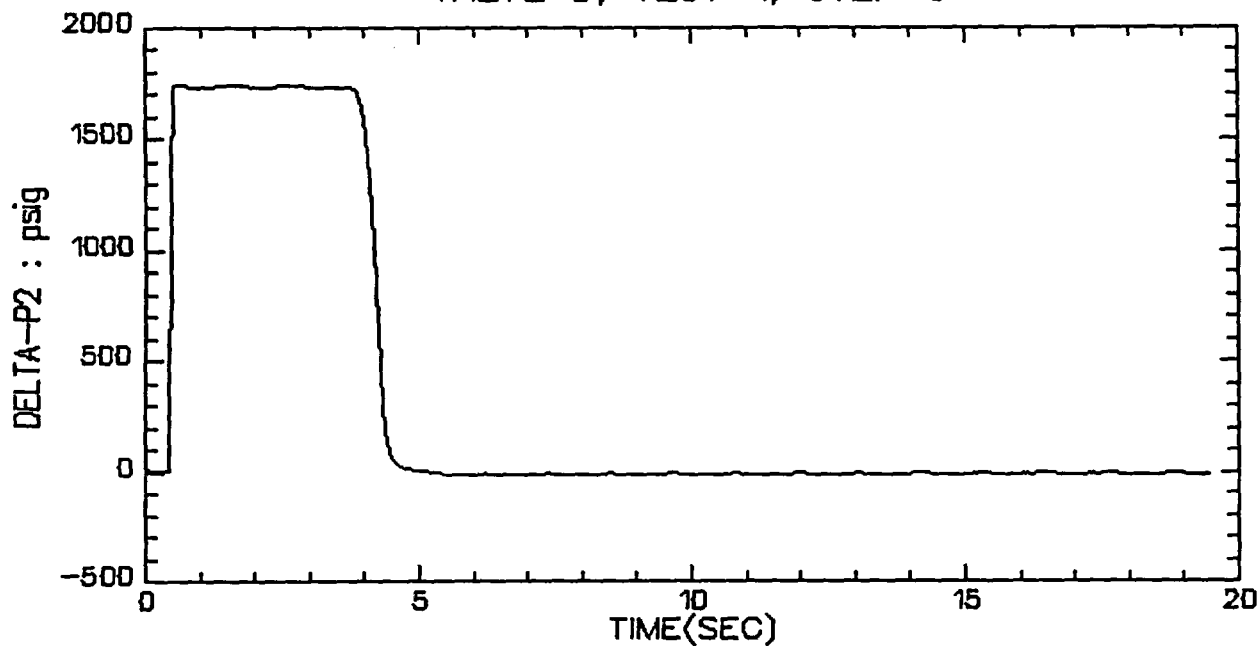

VALVE B, TEST 1, STEP 3

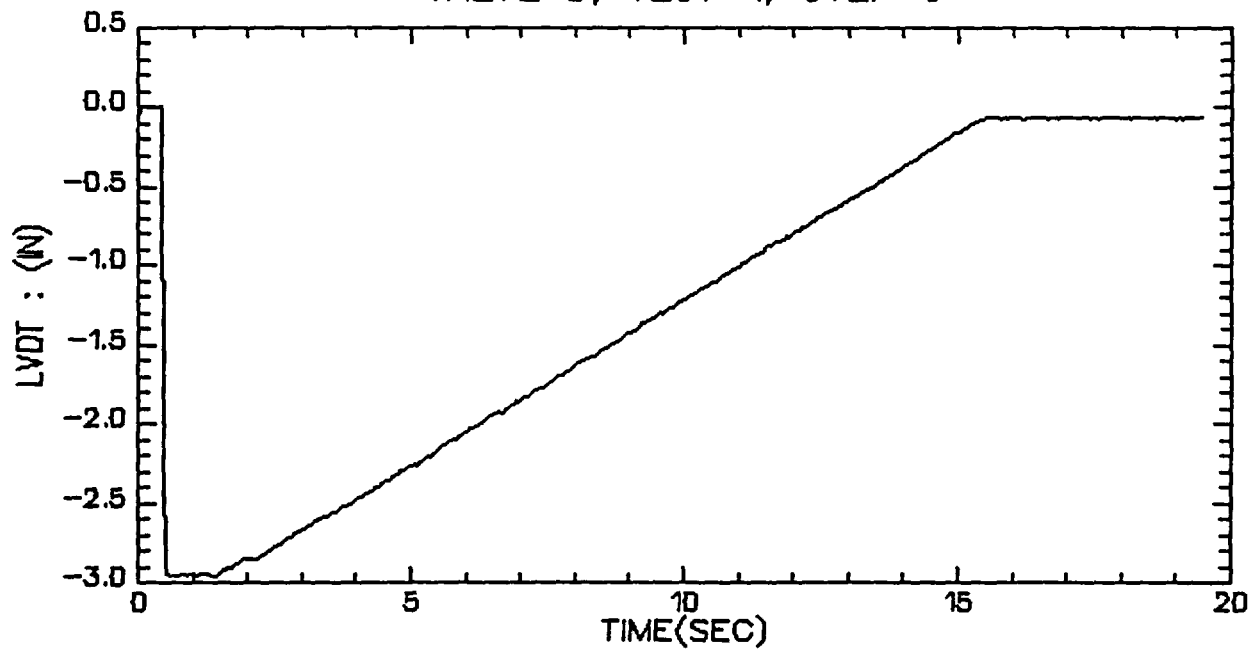

VALVE B, TEST 1, STEP 3

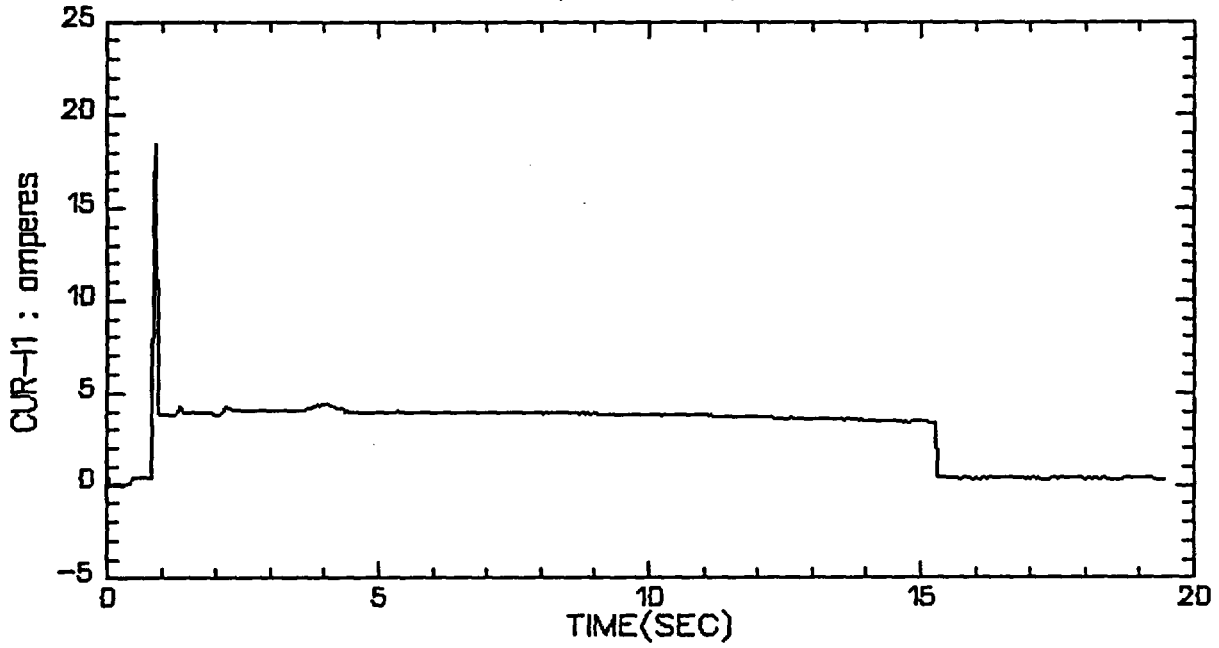

VALVE B, TEST 1, STEP 3

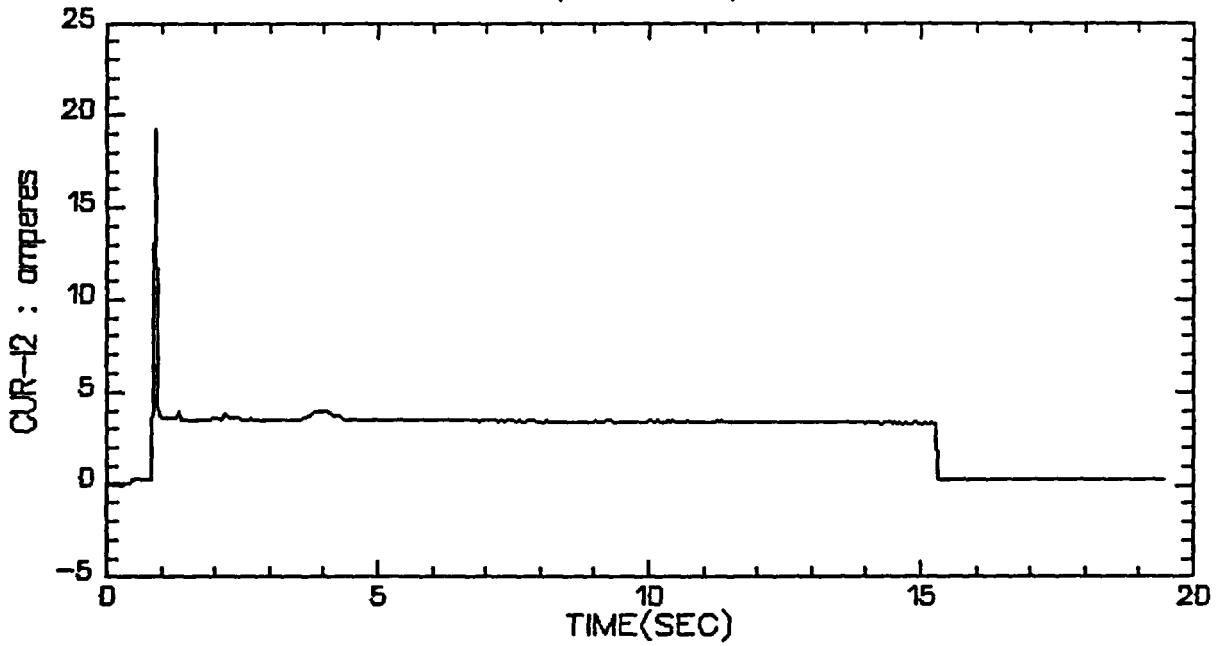

VALVE B, TEST 1, STEP 3

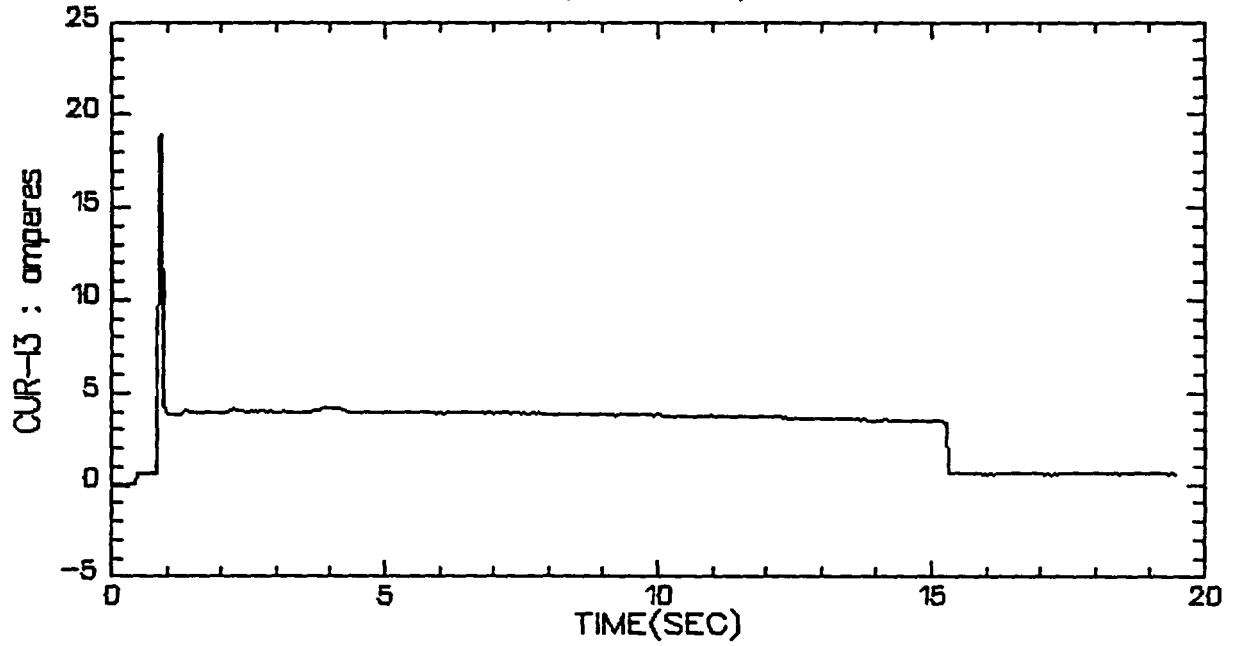

VALVE B, TEST 1, STEP 3

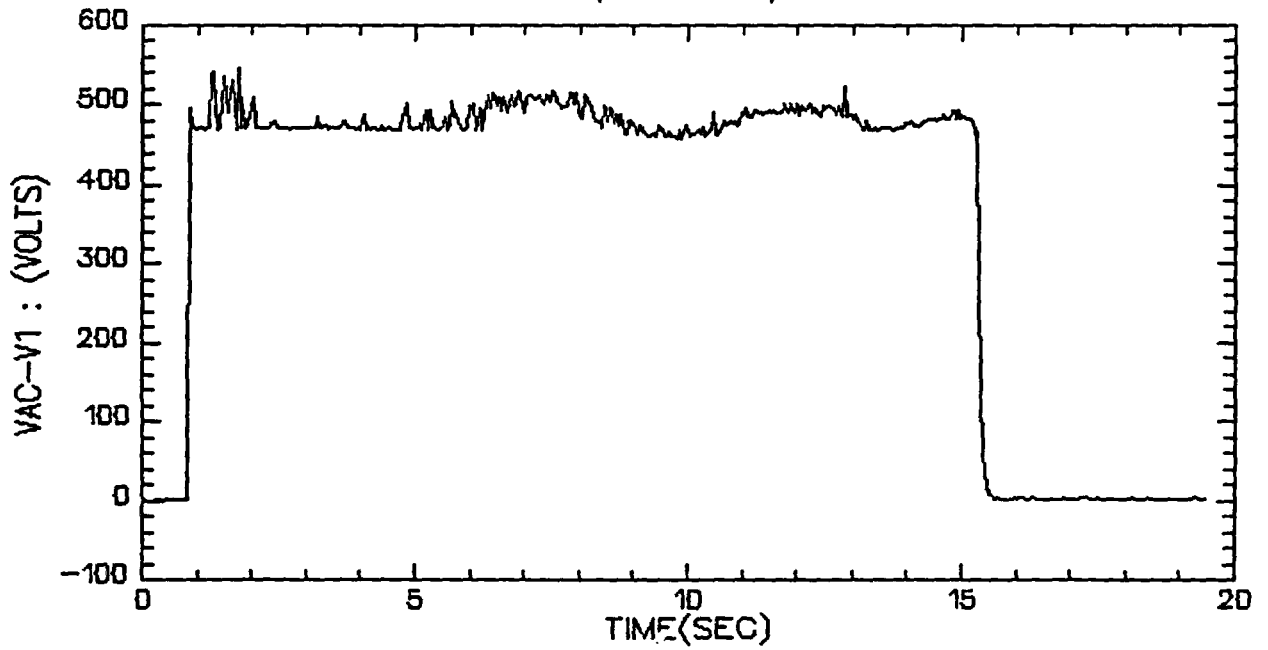

VALVE B, TEST 1, STEP 3

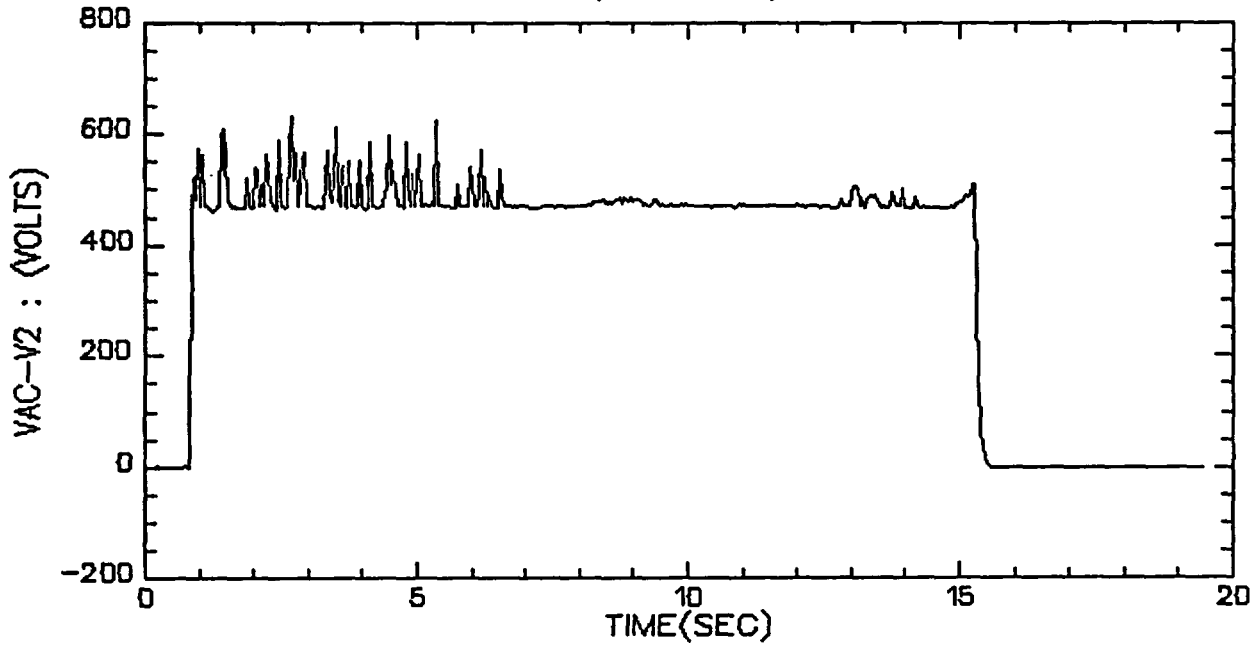

VALVE B, TEST 1, STEP 3

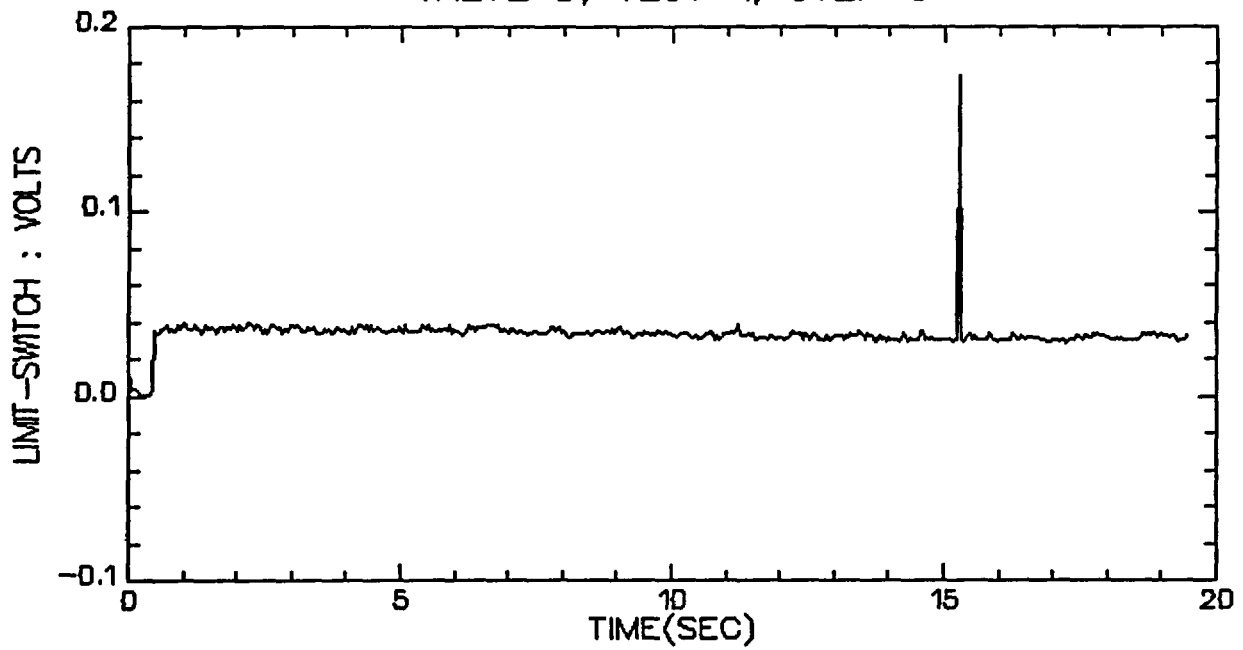

VALVE B, TEST 1, STEP 3

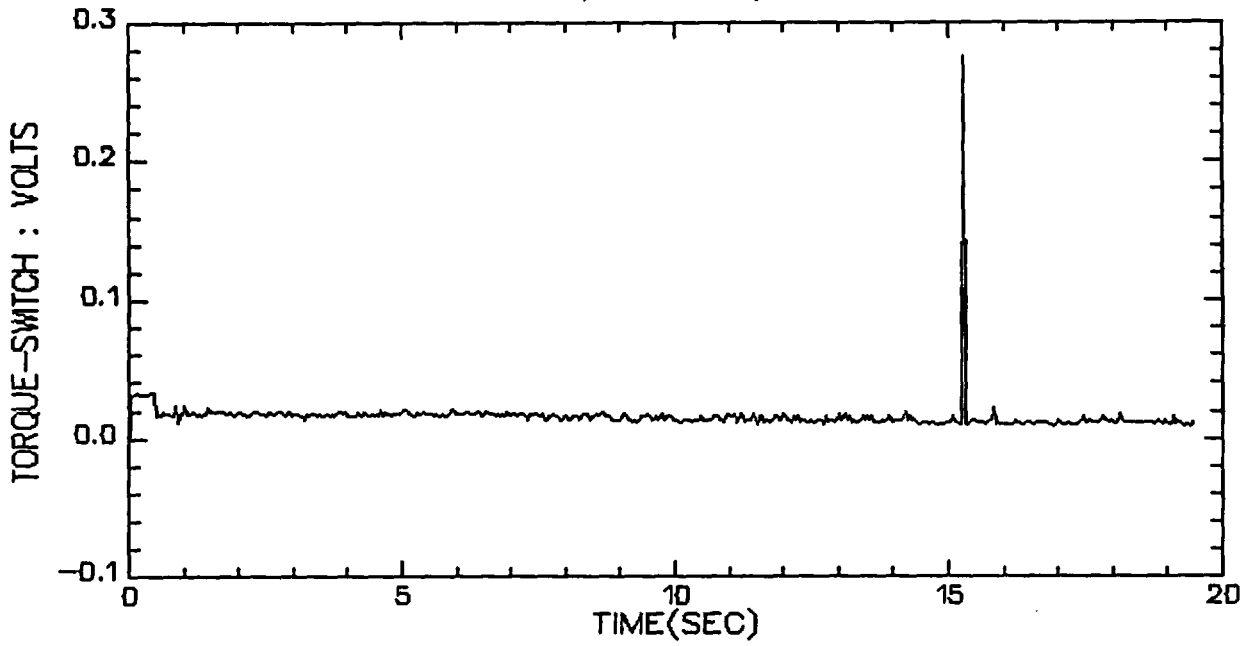

VALVE B, TEST 1, STEP 3

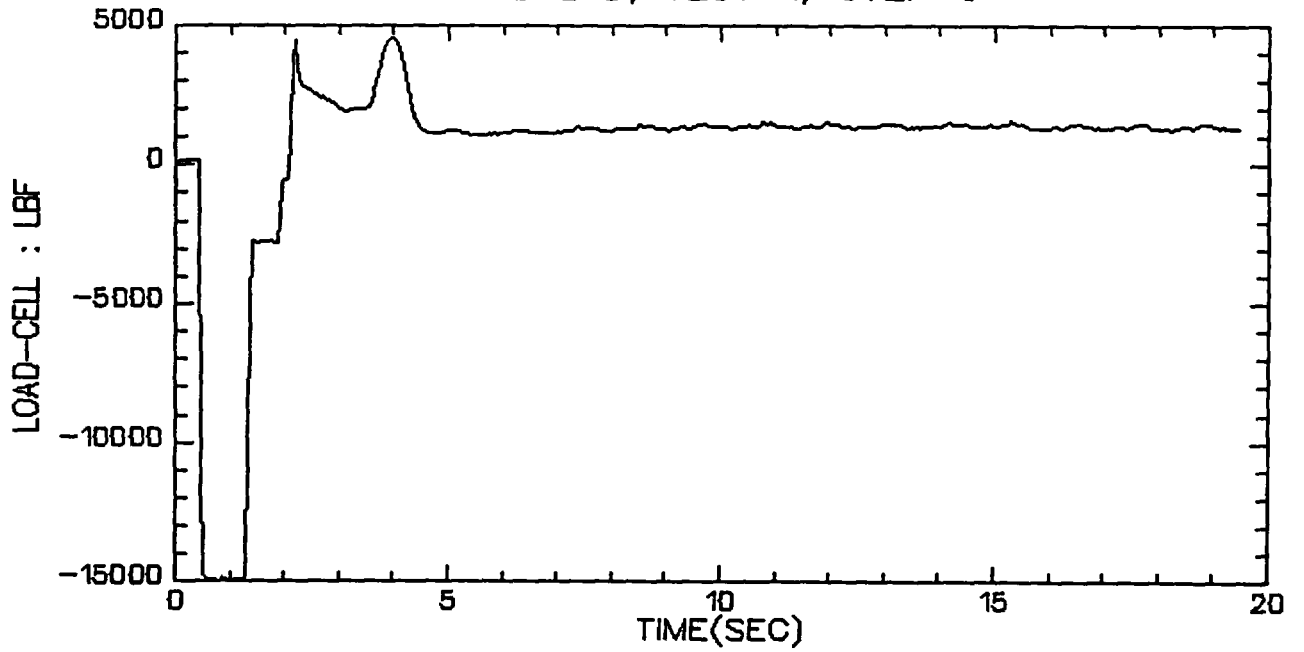

VALVE B, TEST 1, STEP 5

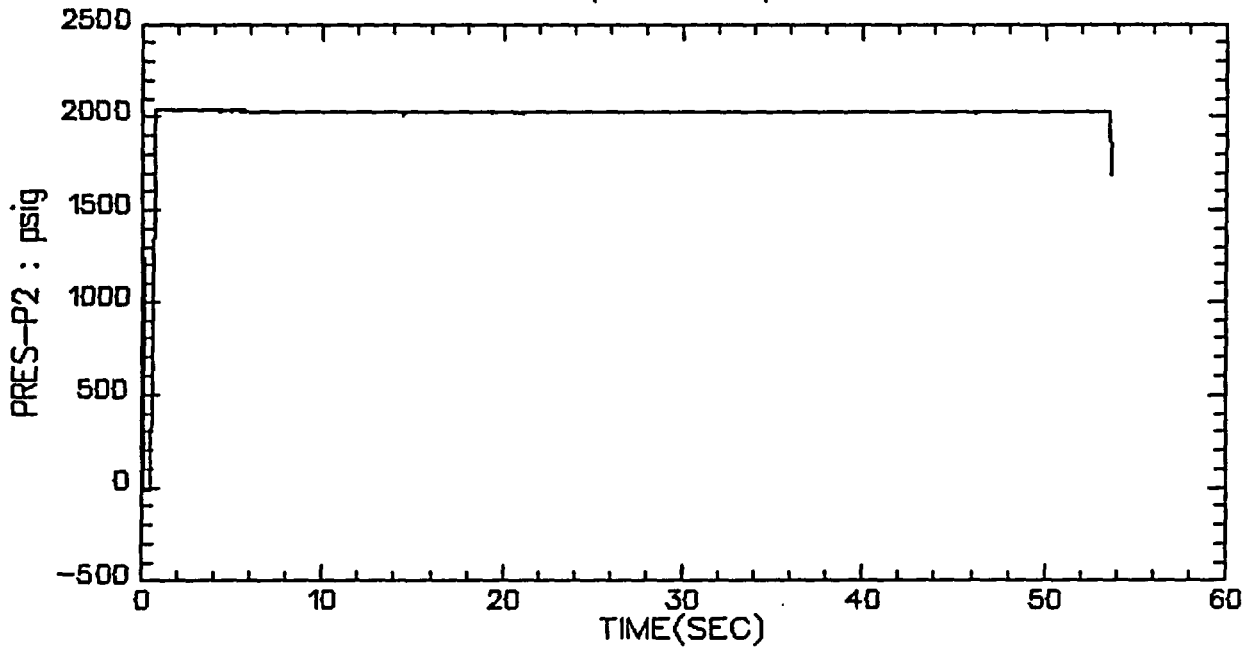

VALVE B, TEST 1, STEP 5

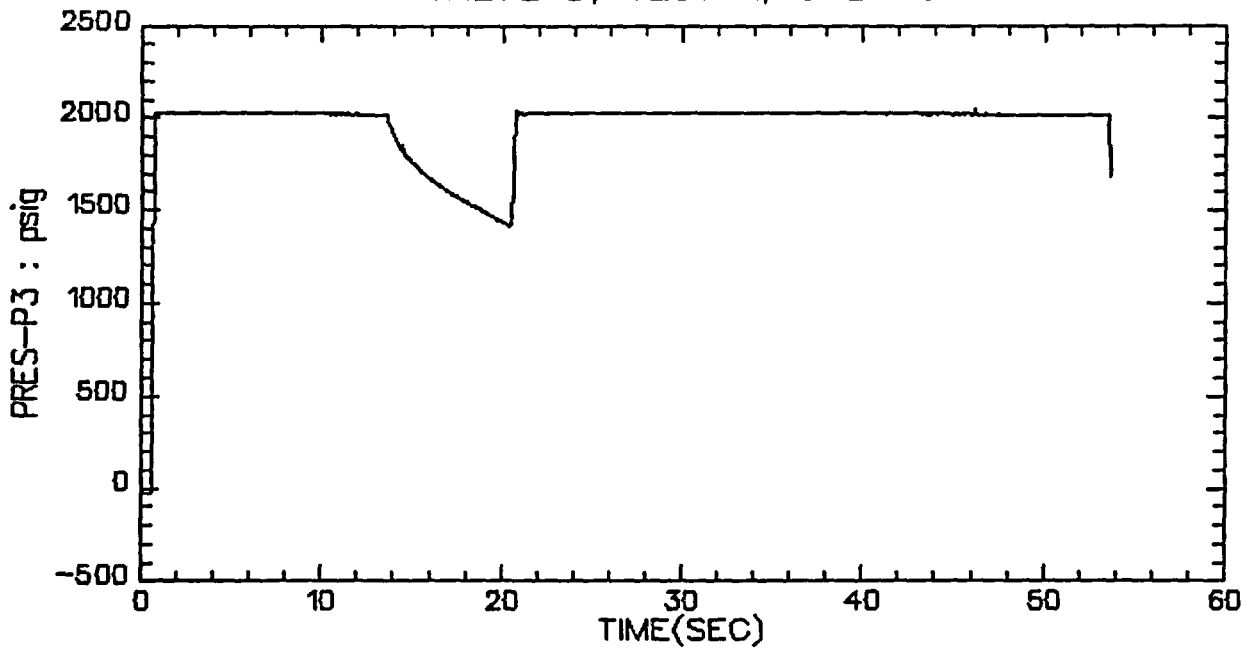

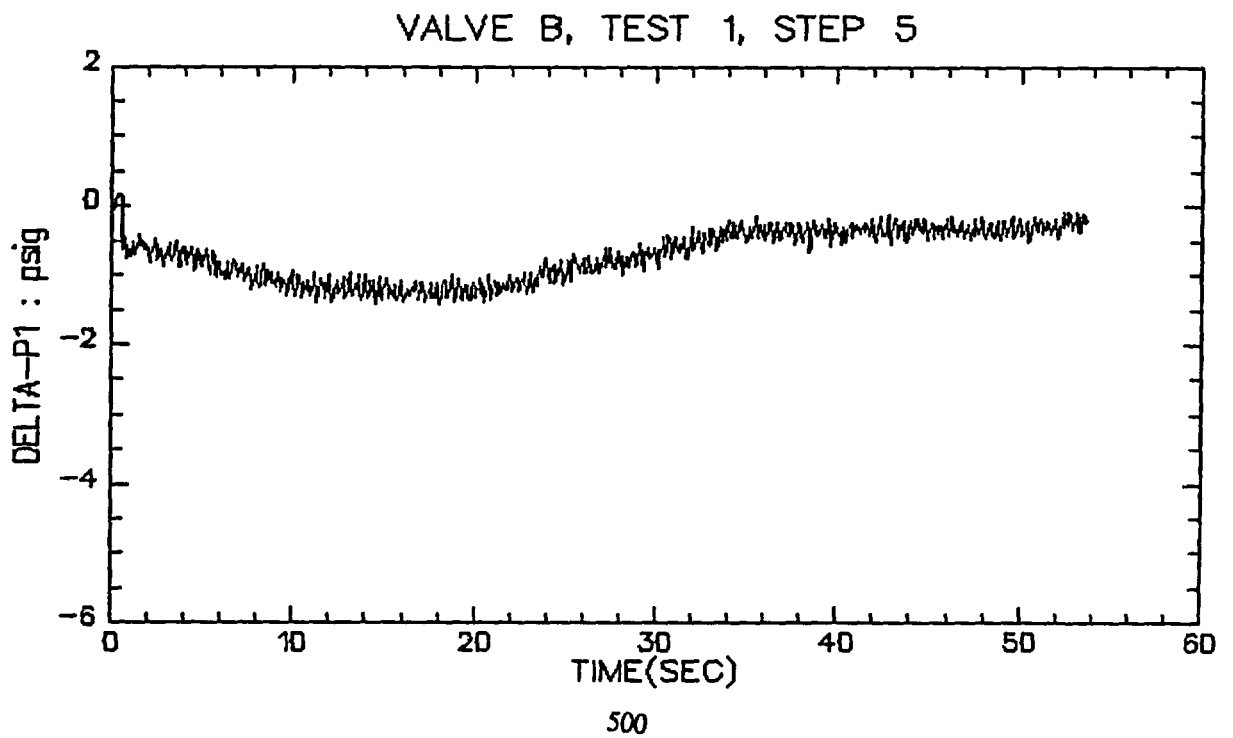
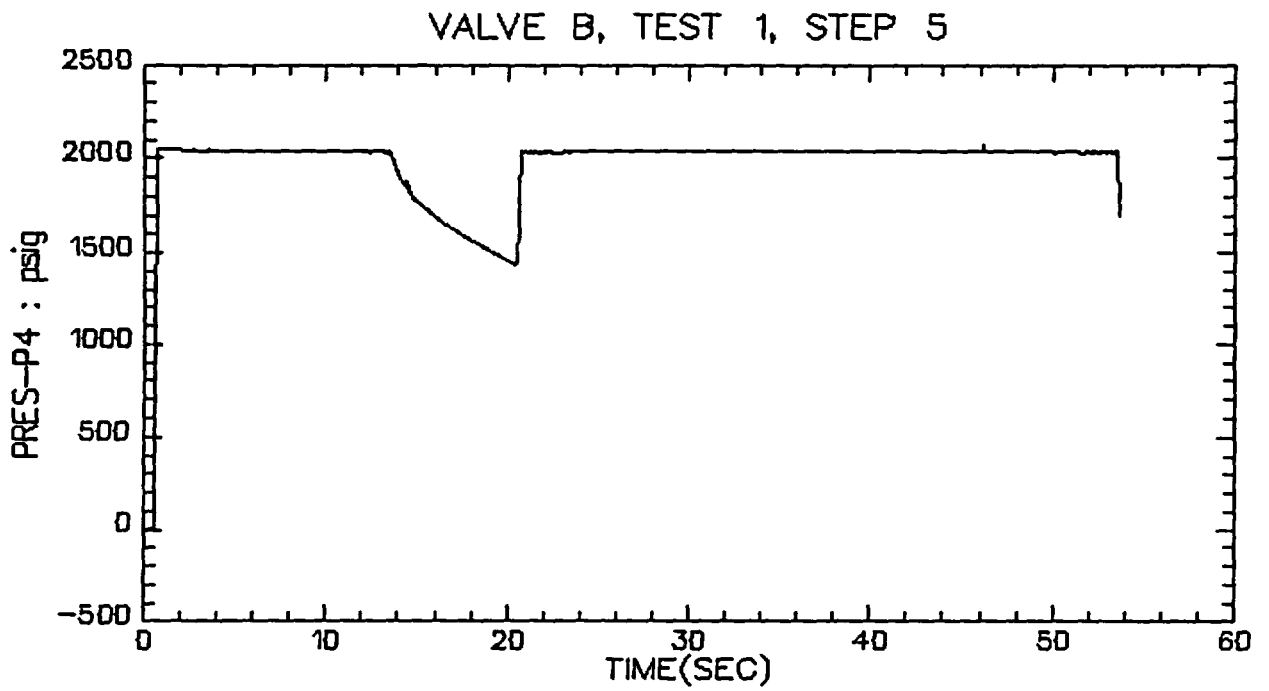

VALVE B, TEST 1, STEP 5

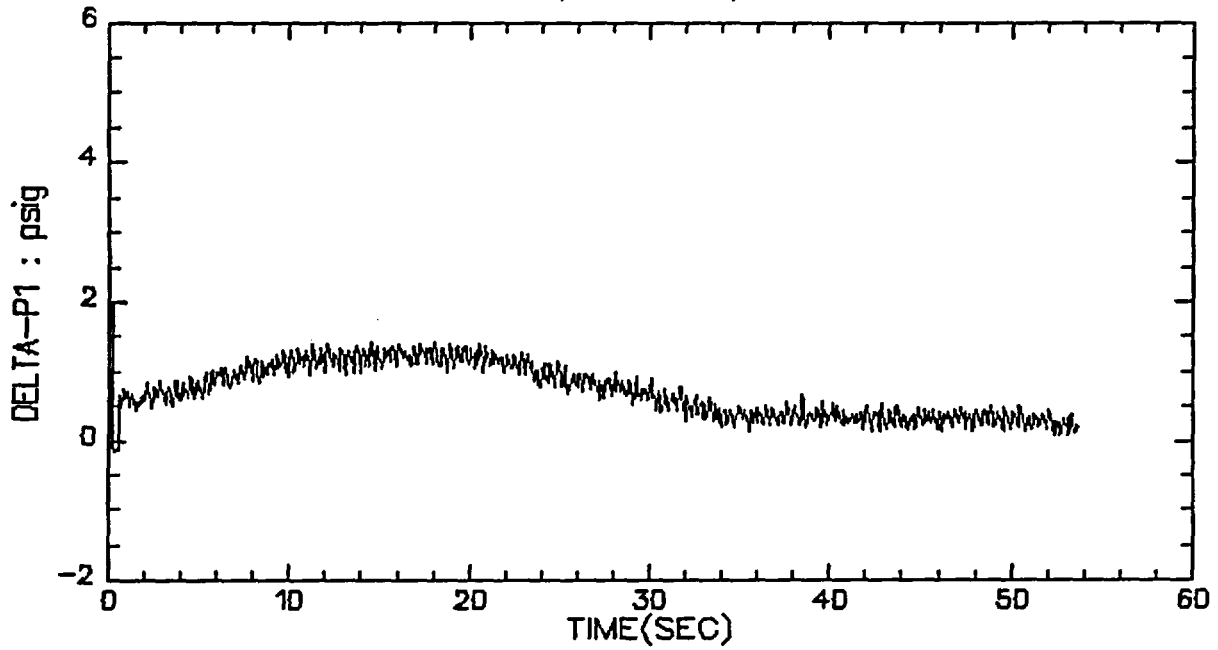

VALVE B, TEST 1, STEP 5

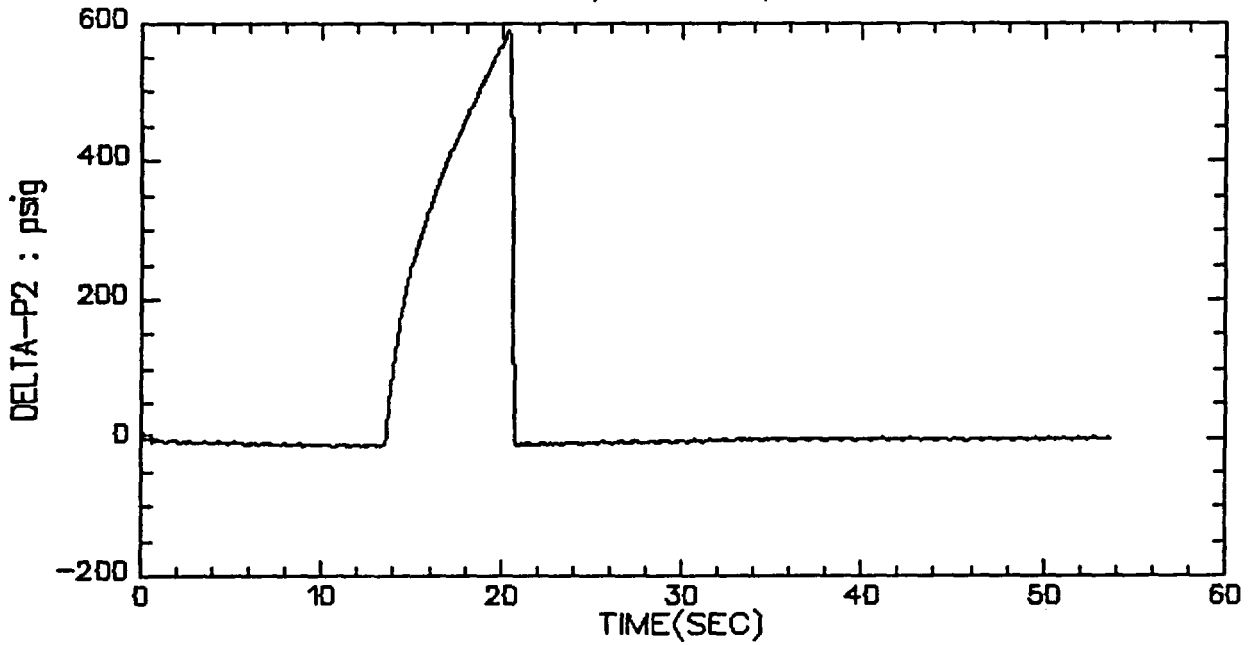

VALVE B, TEST 1, STEP 5

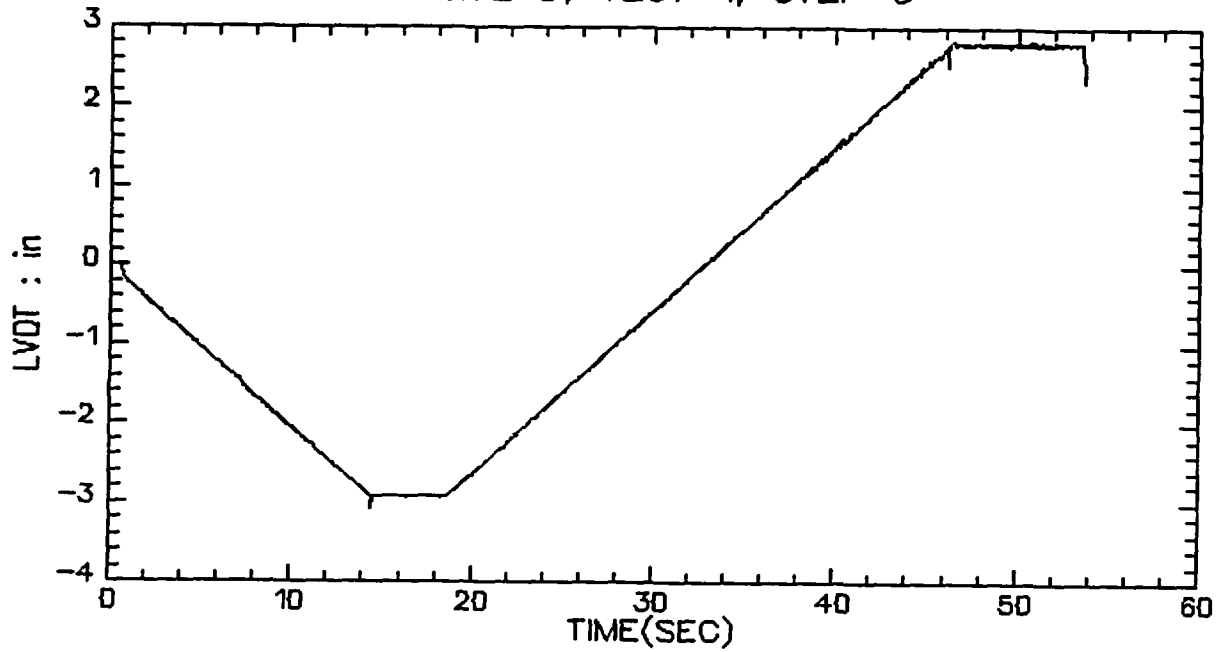

VALVE B, TEST 1, STEP 5

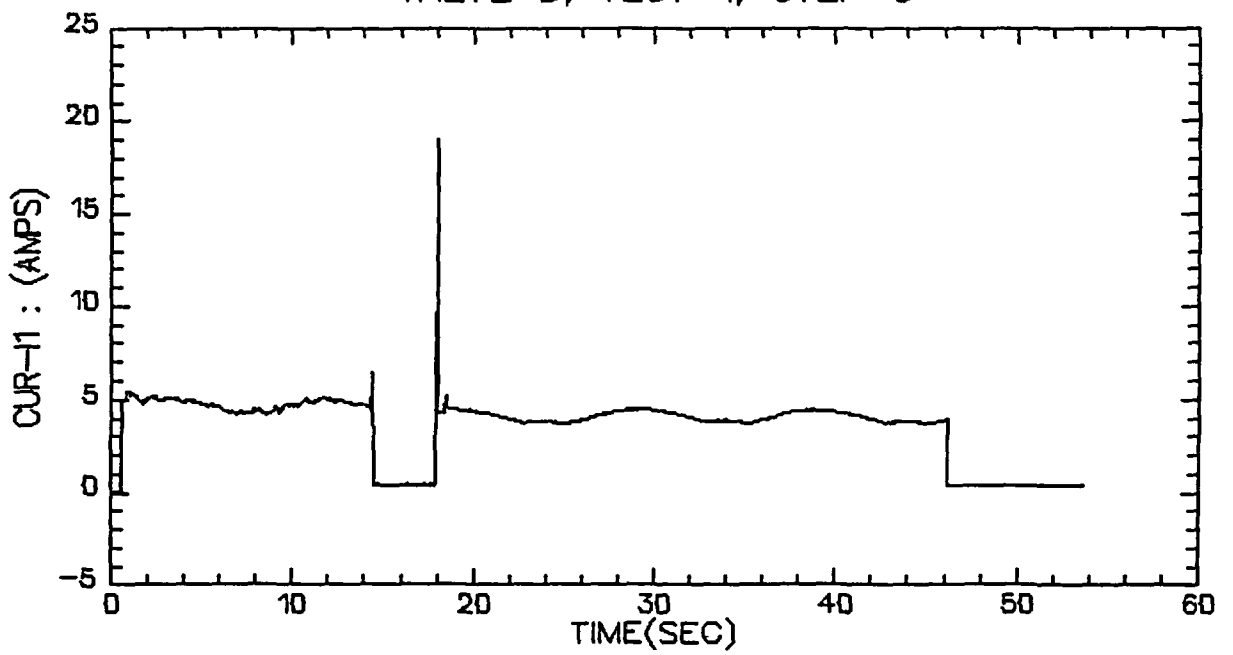

VALVE B, TEST 1, STEP 5

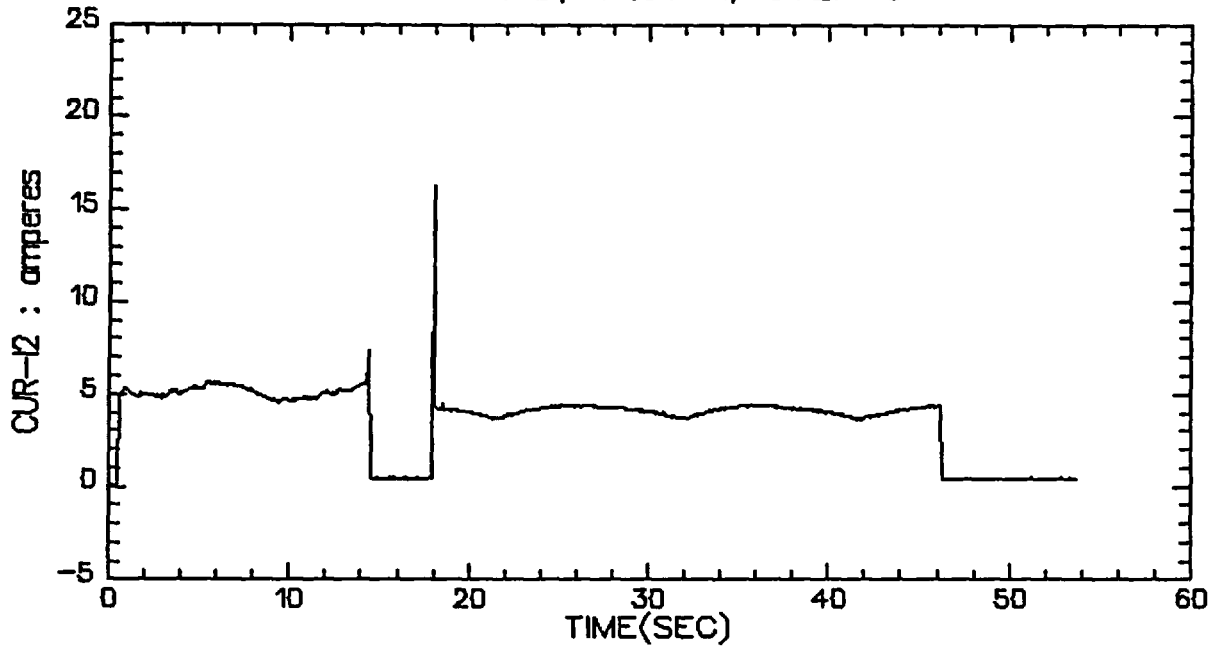

VALVE B, TEST 1, STEP 5

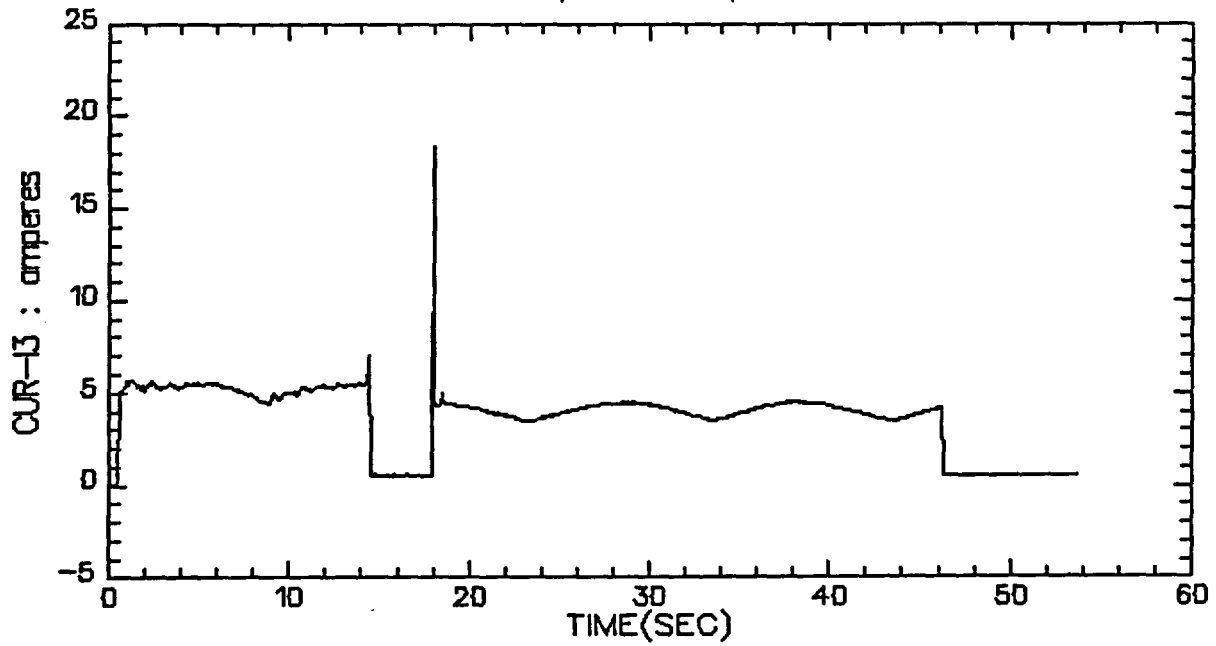

VALVE B, TEST 1, STEP 5

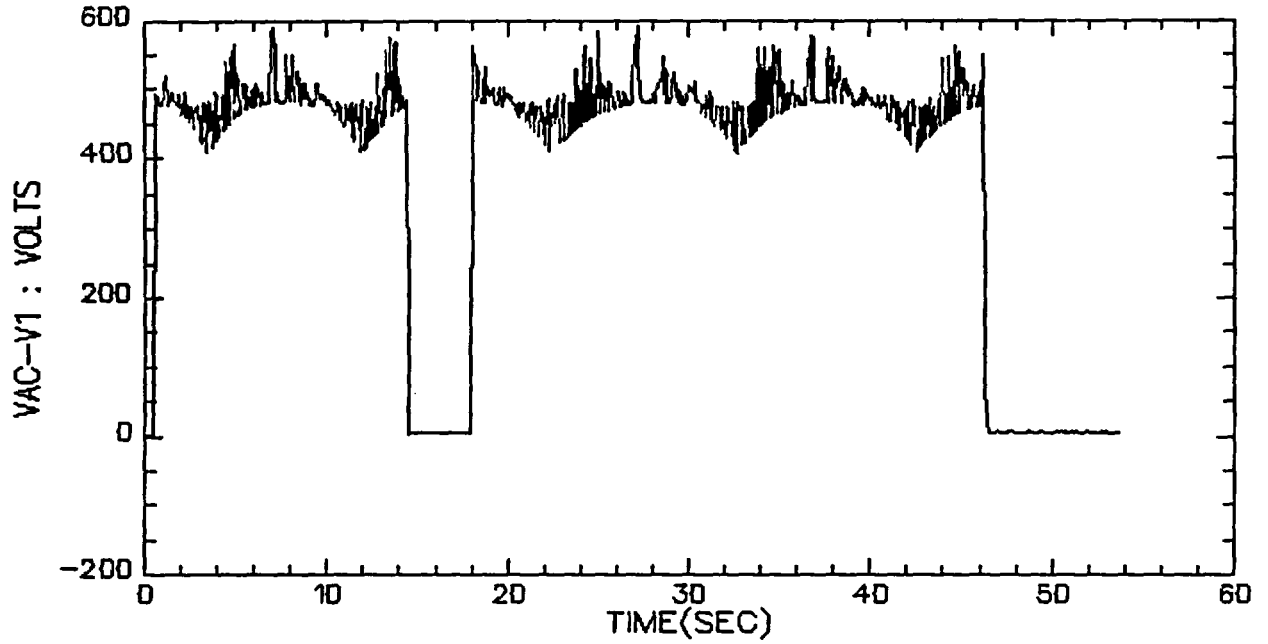

VALVE B, TEST 1, STEP 5

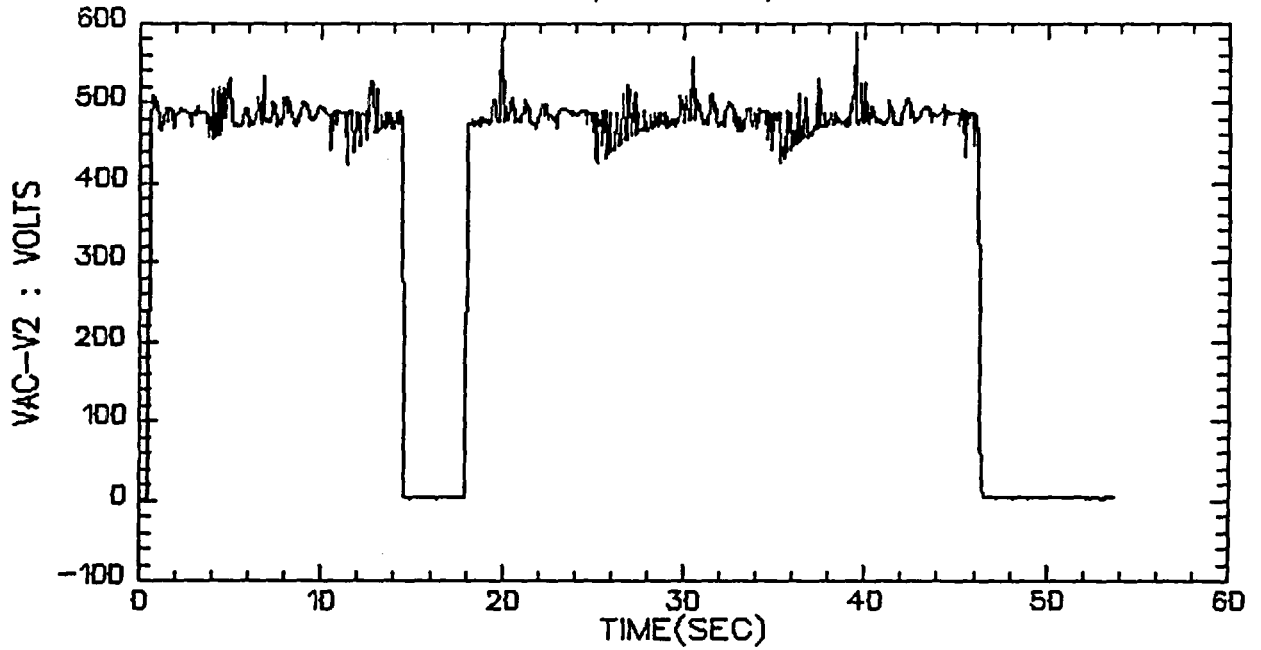

VALVE B, TEST 1, STEP 5

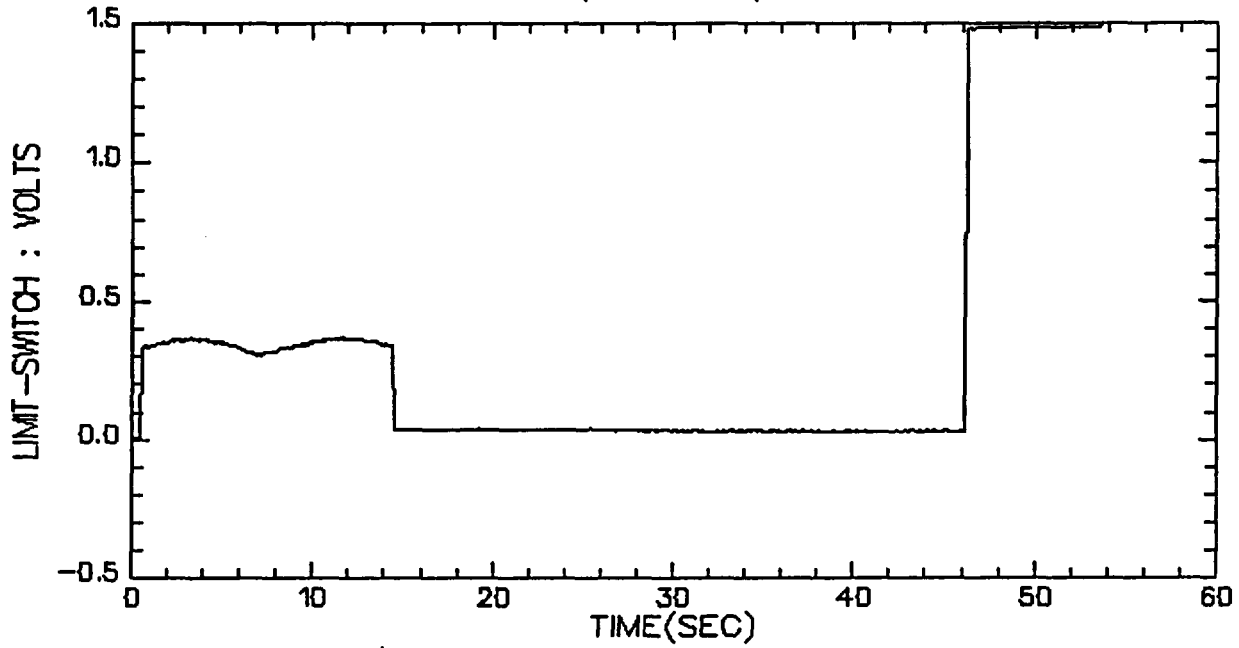

VALVE B, TEST 1, STEP 5

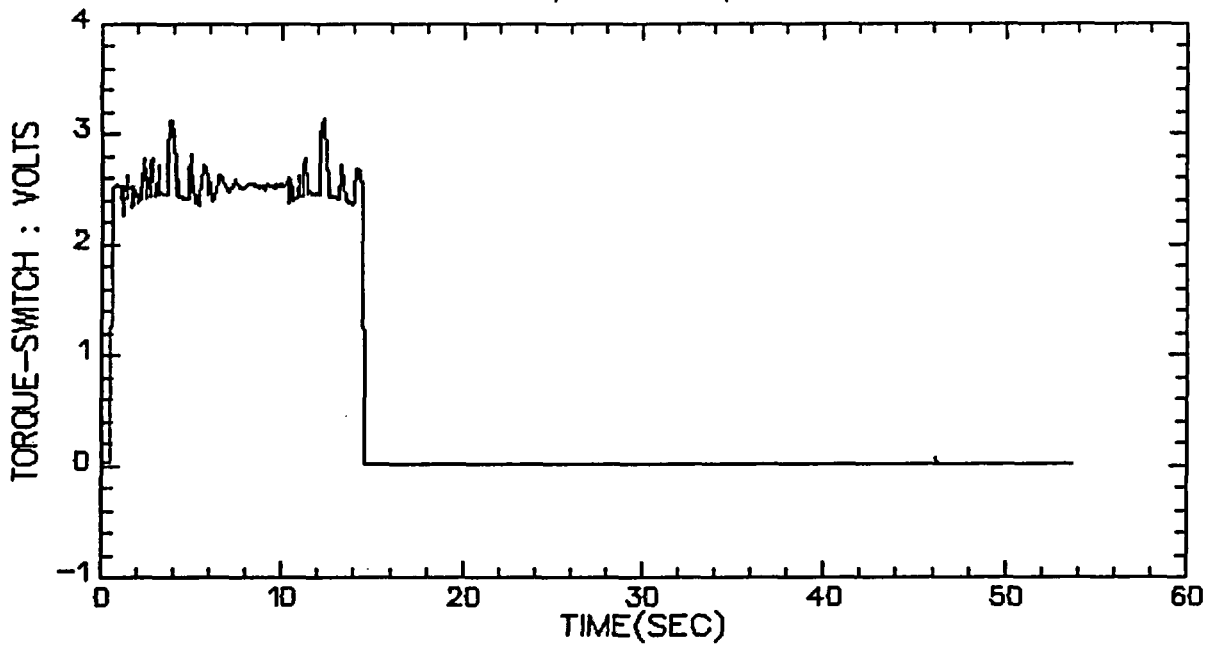

VALVE B, TEST 1, STEP 5

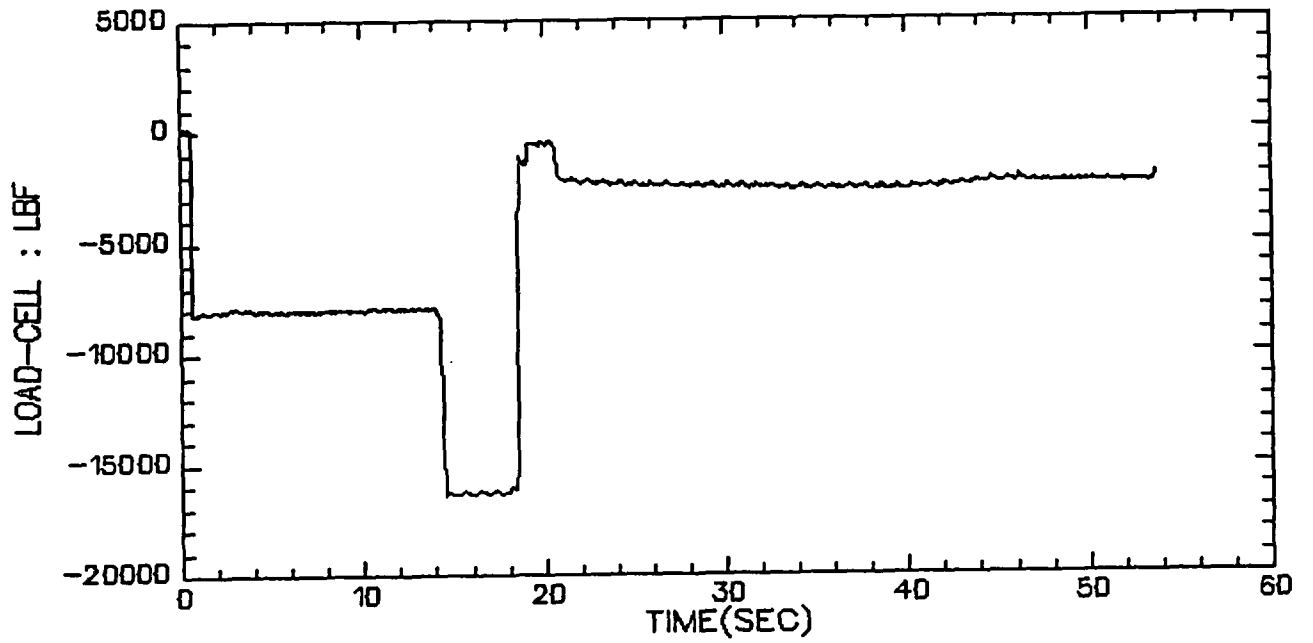

VALVE B, TEST 1, STEP 6

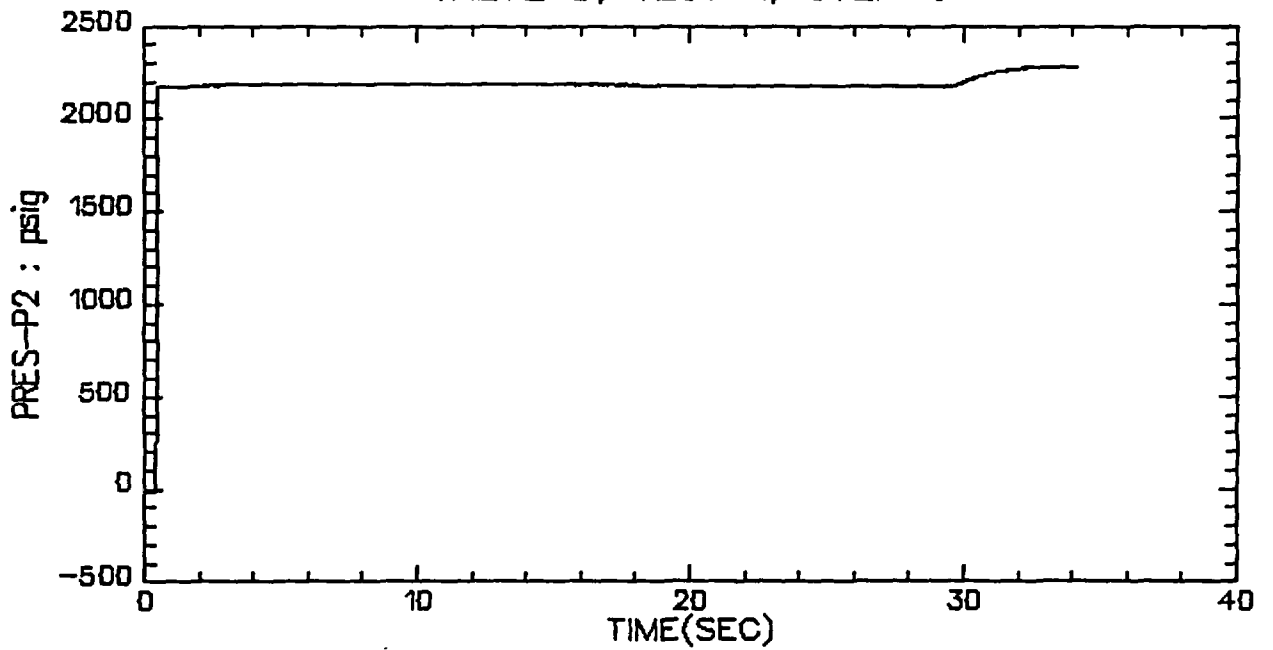

VALVE B, TEST 1, STEP 6

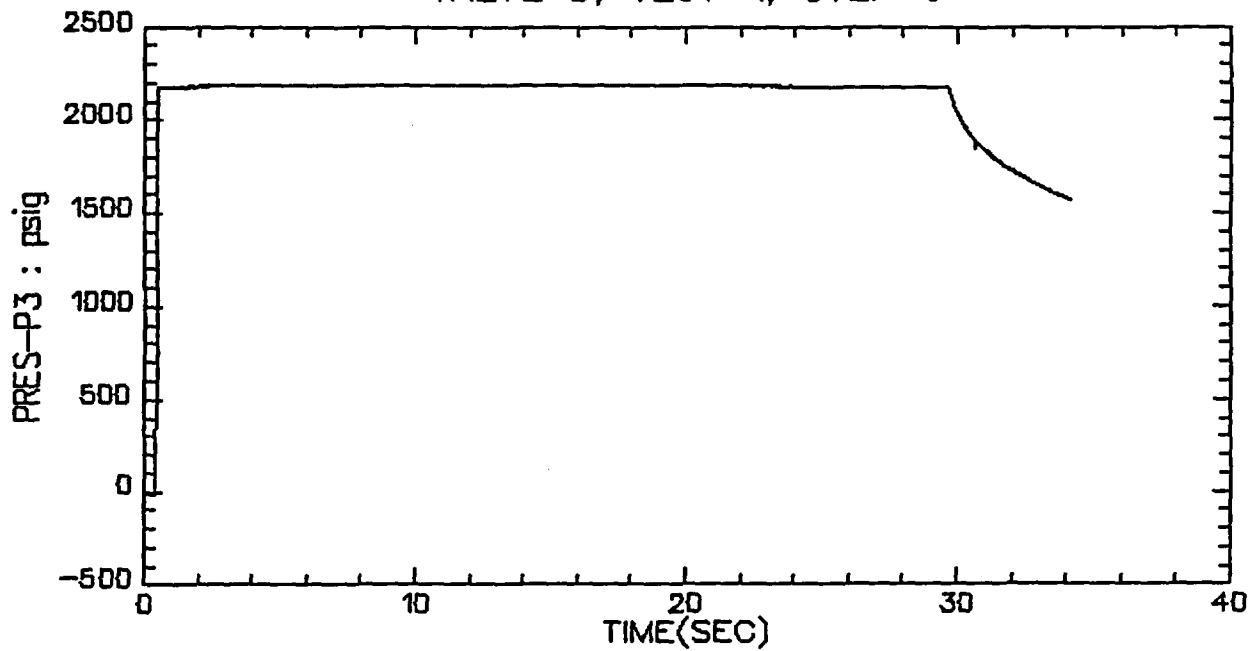

VALVE B, TEST 1, STEP 6

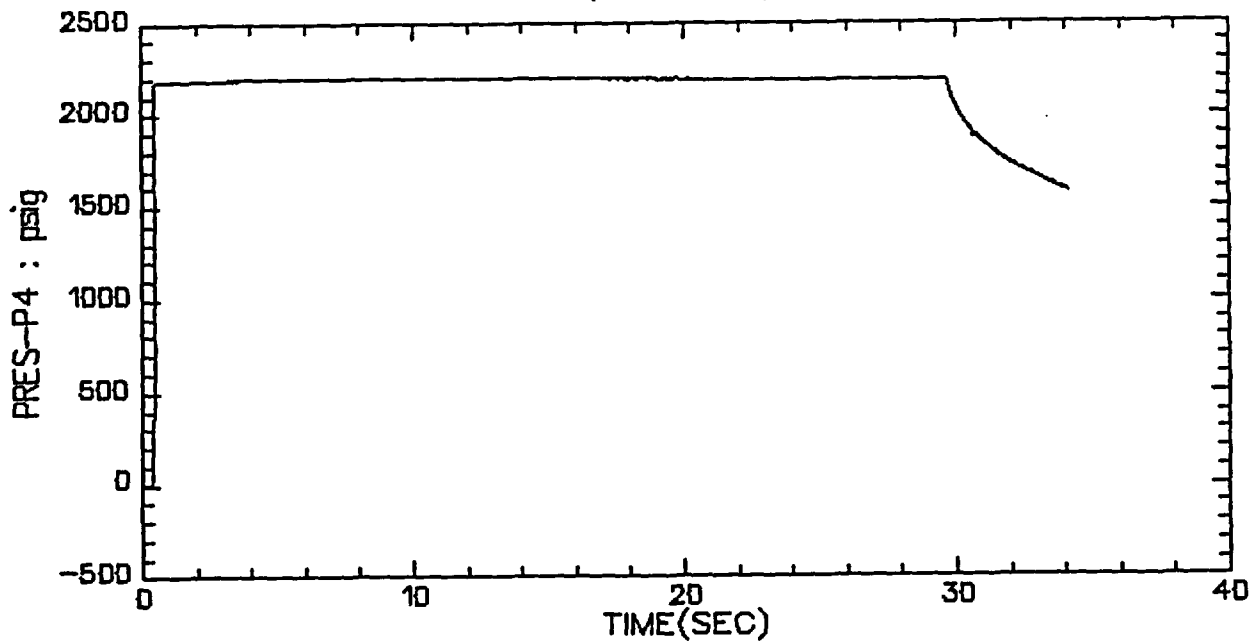

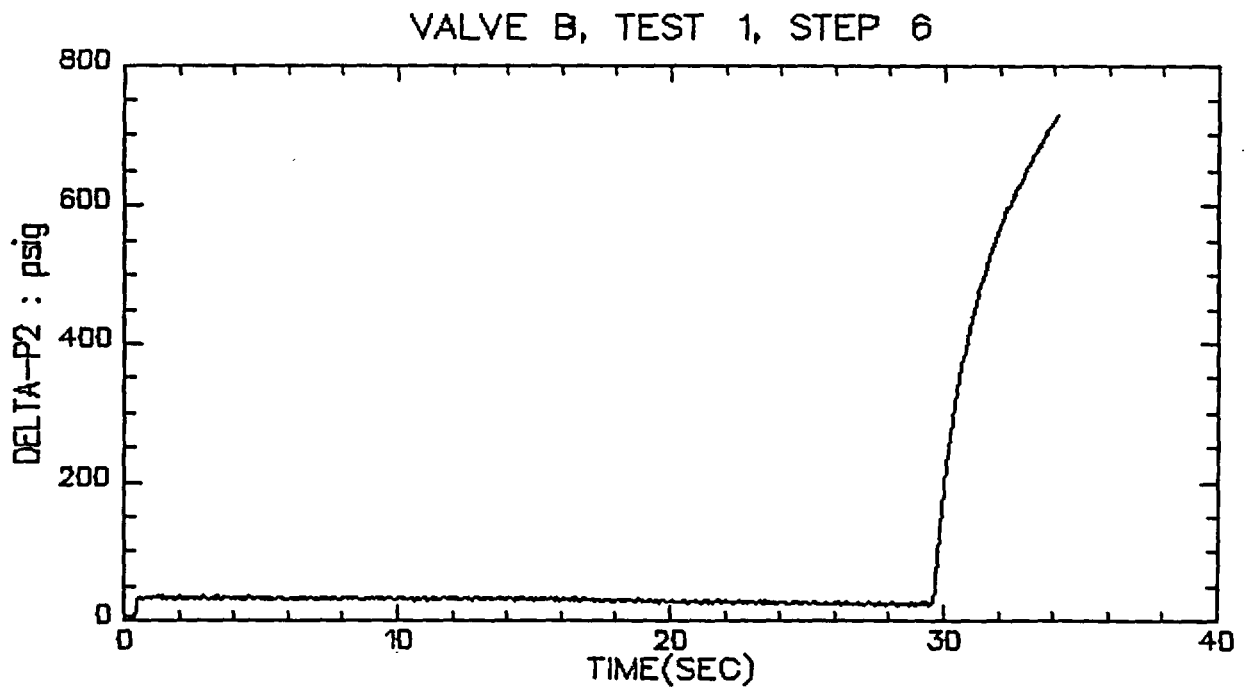
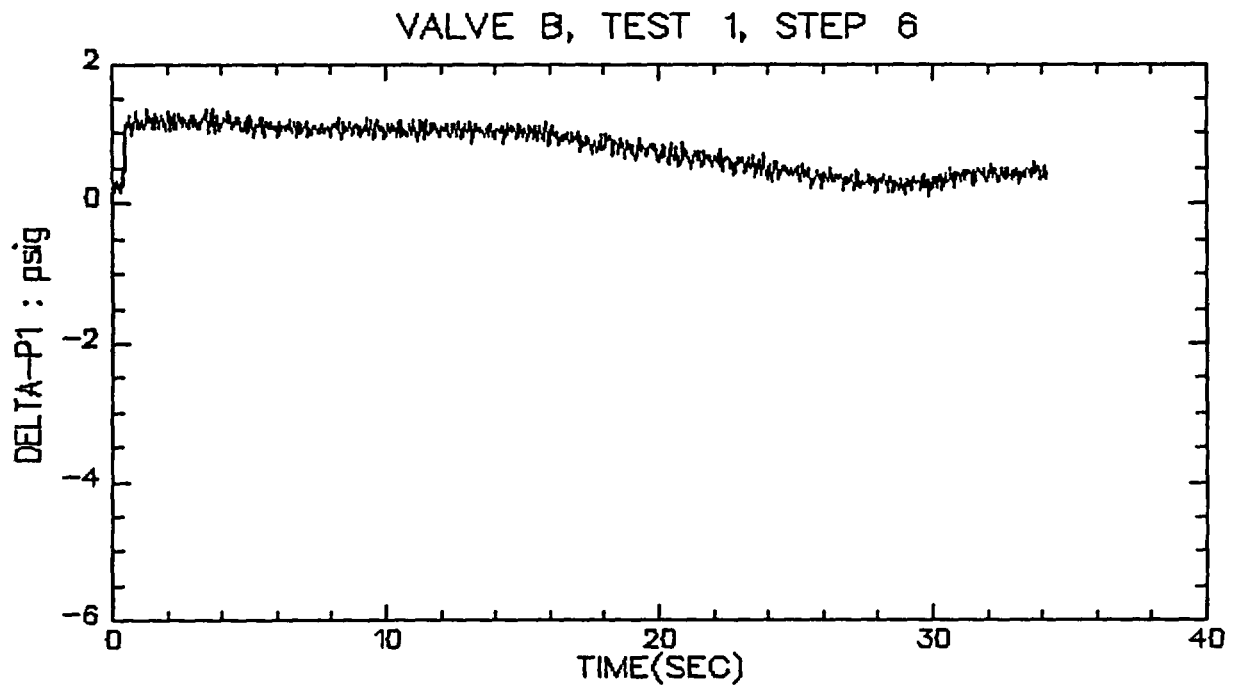

VALVE B, TEST 1, STEP 6

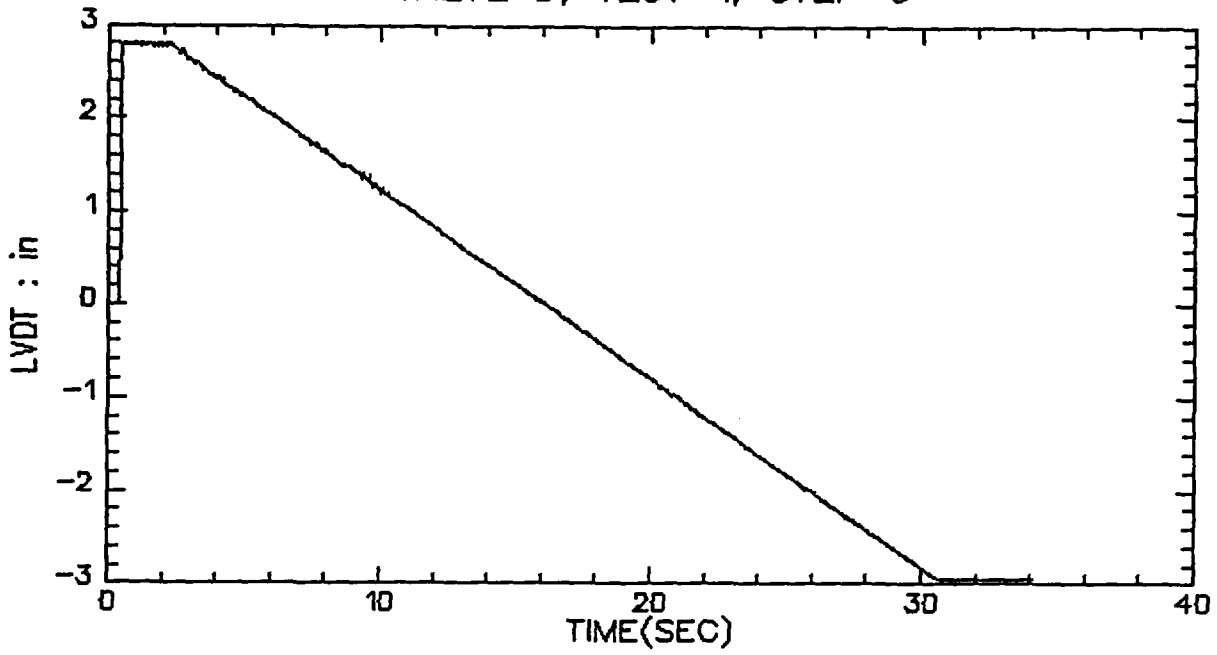

VALVE B, TEST 1, STEP 6

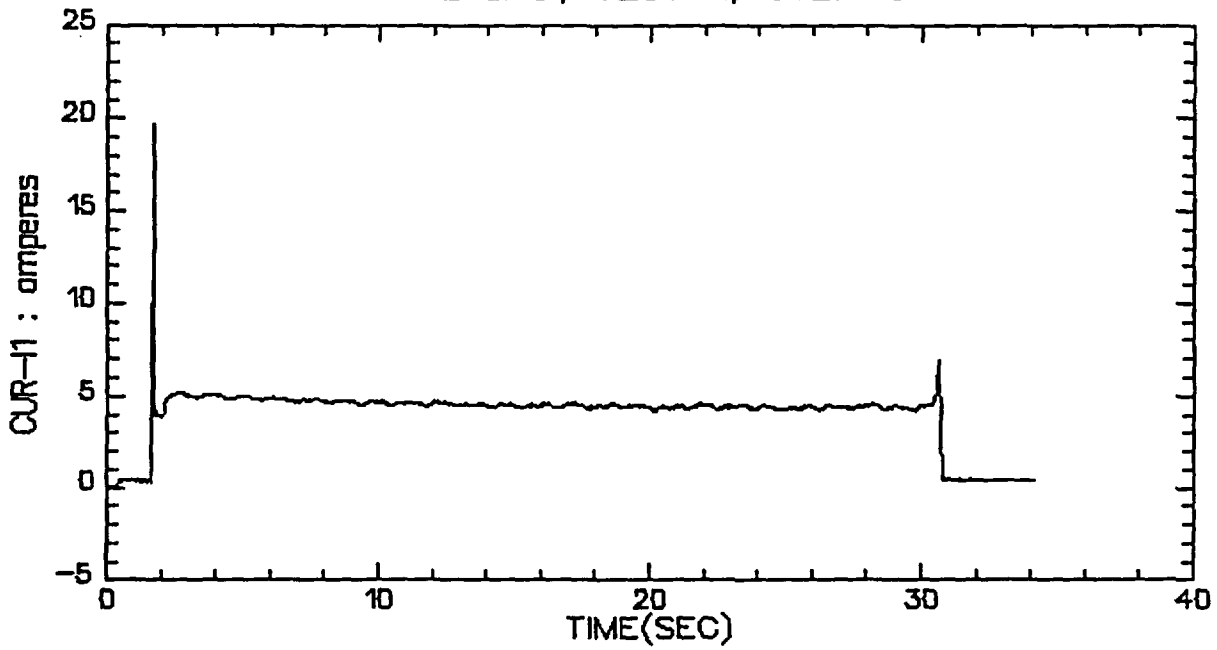

VALVE B, TEST 1, STEP 6

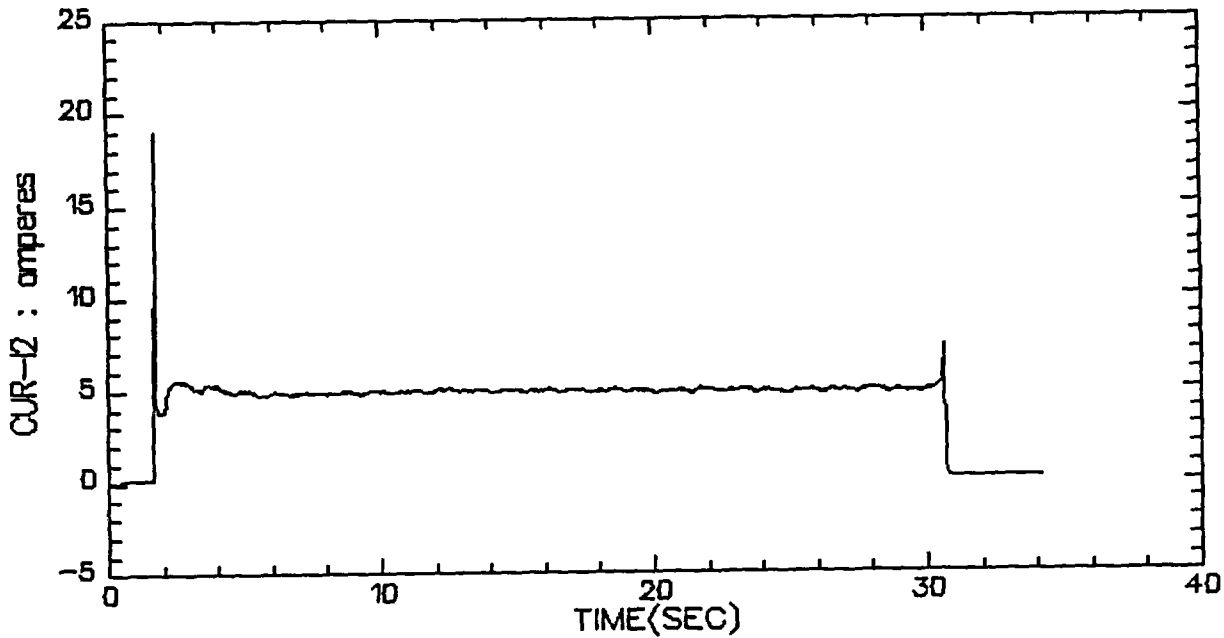

VALVE B, TEST 1, STEP 6

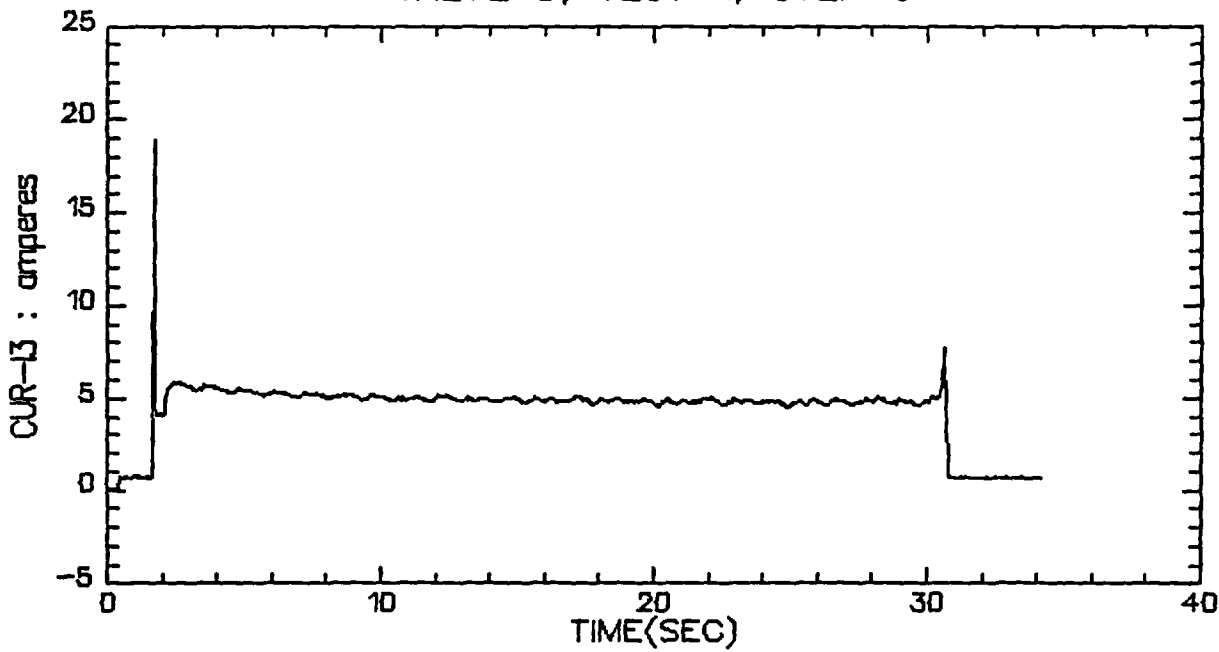

VALVE B, TEST 1, STEP 6

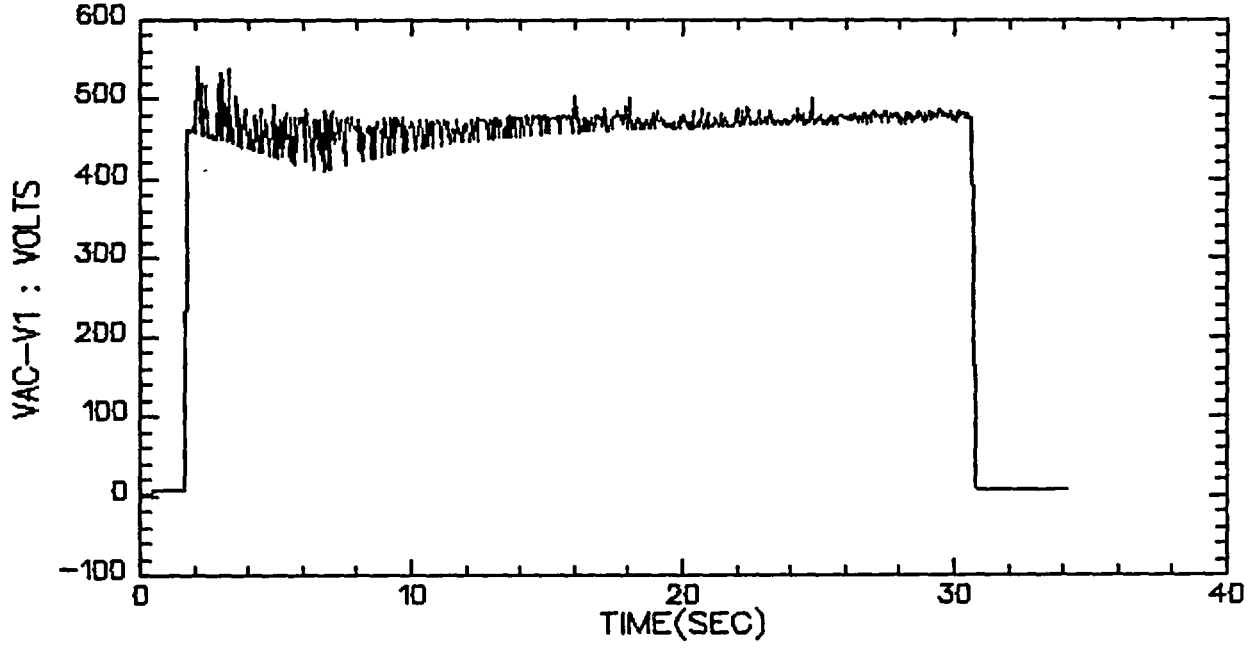

VALVE B, TEST 1, STEP 6

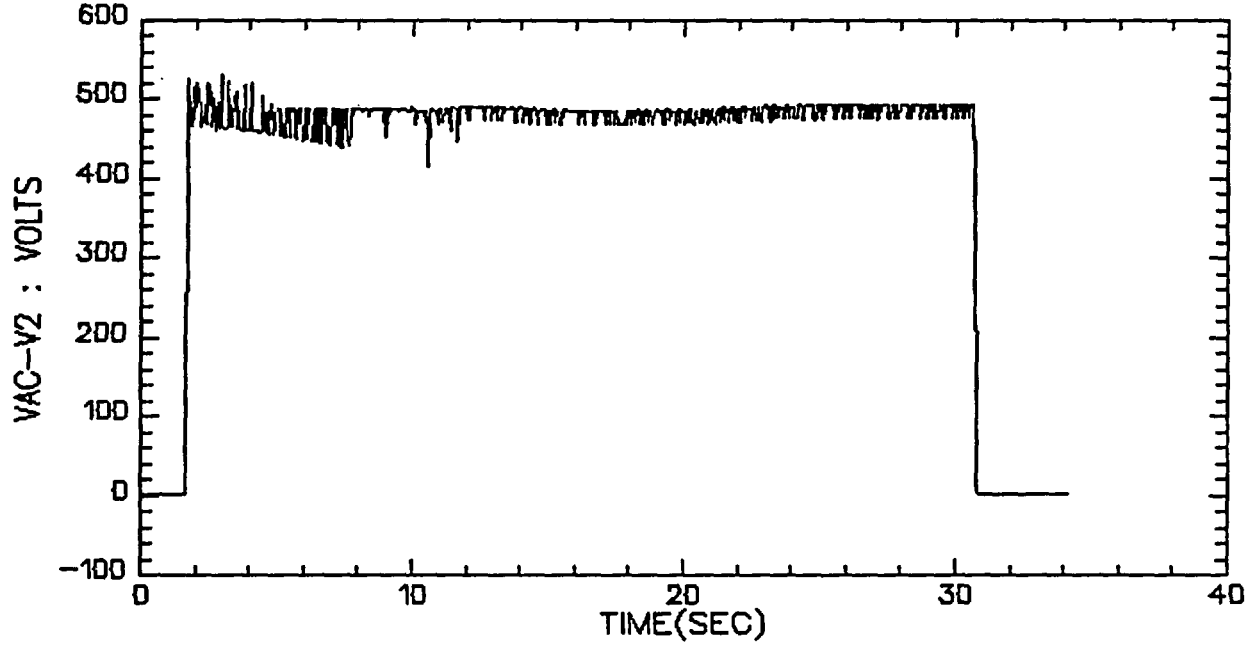

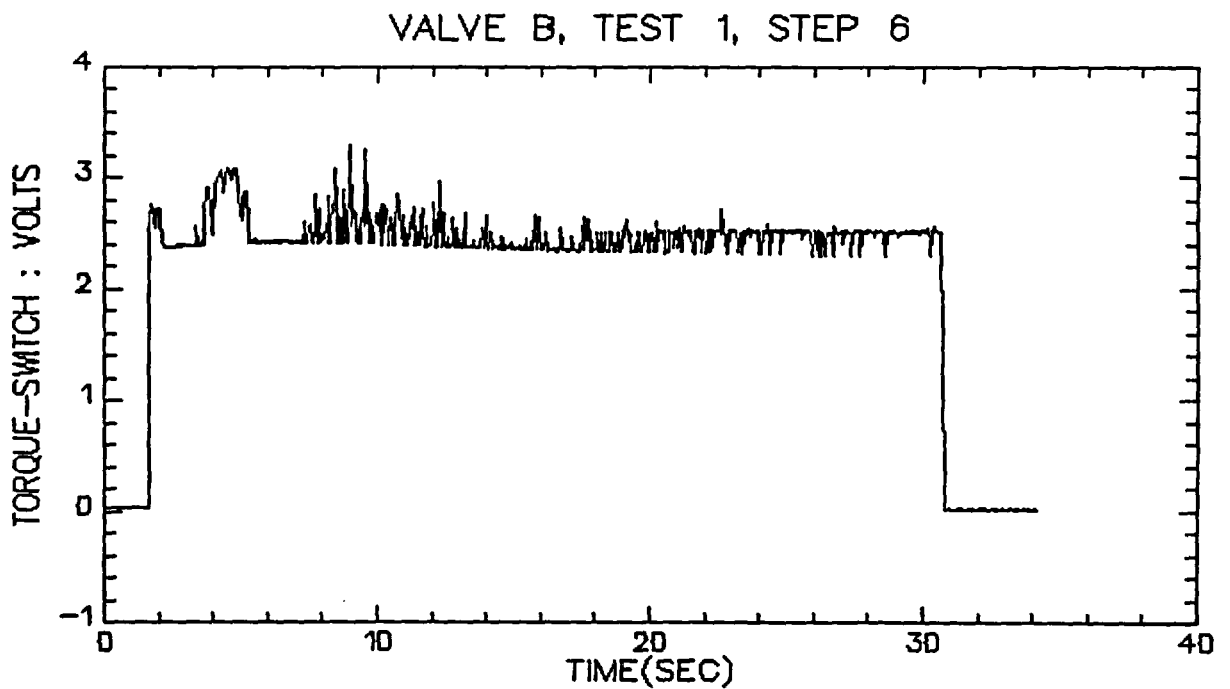
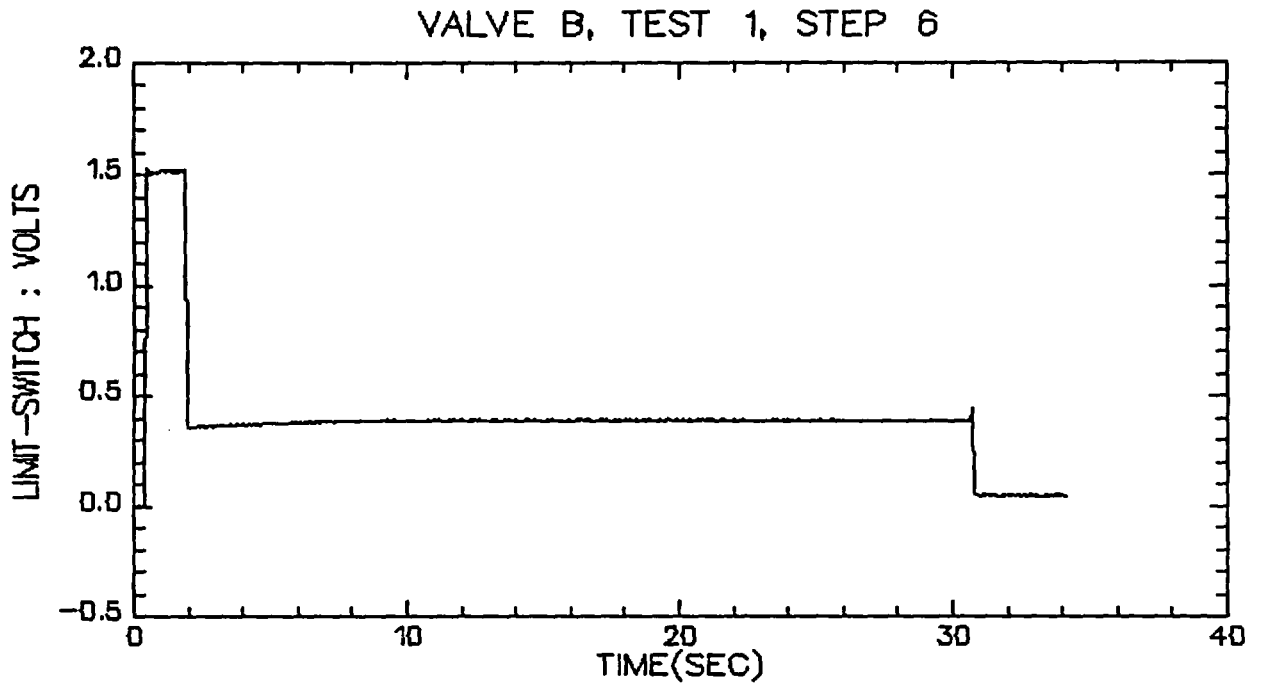

VALVE B, TEST 1, STEP 6

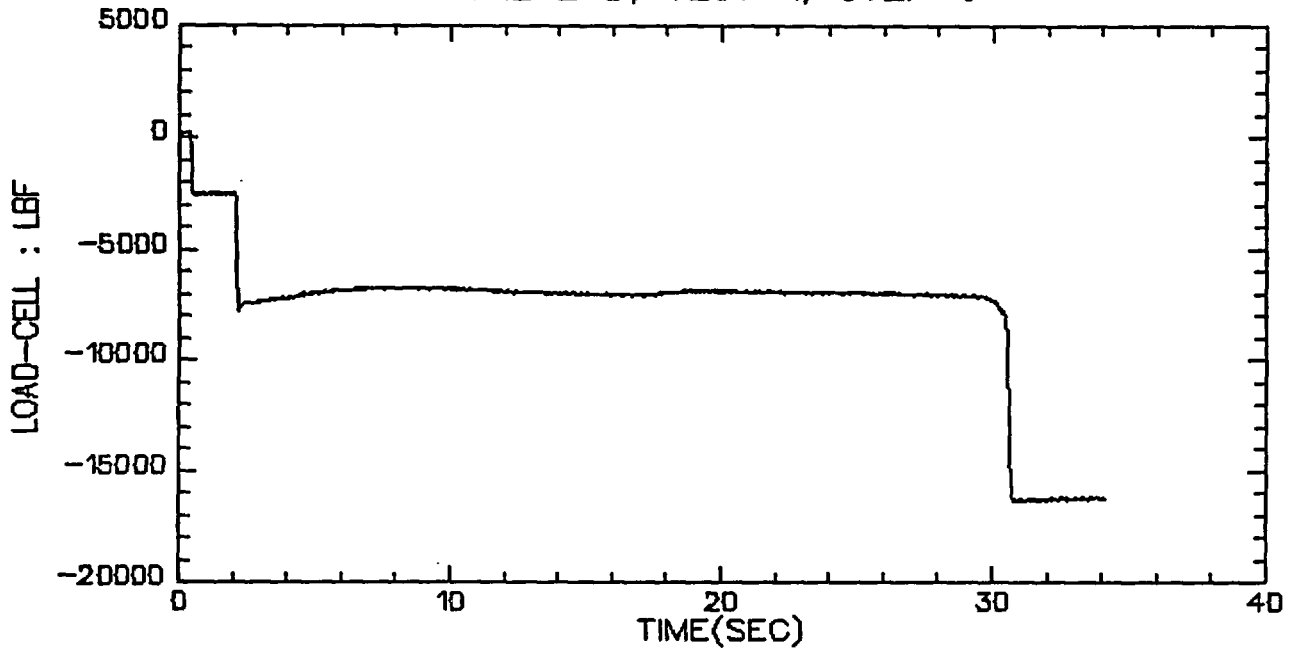

VALVE B, TEST 1, STEP 7

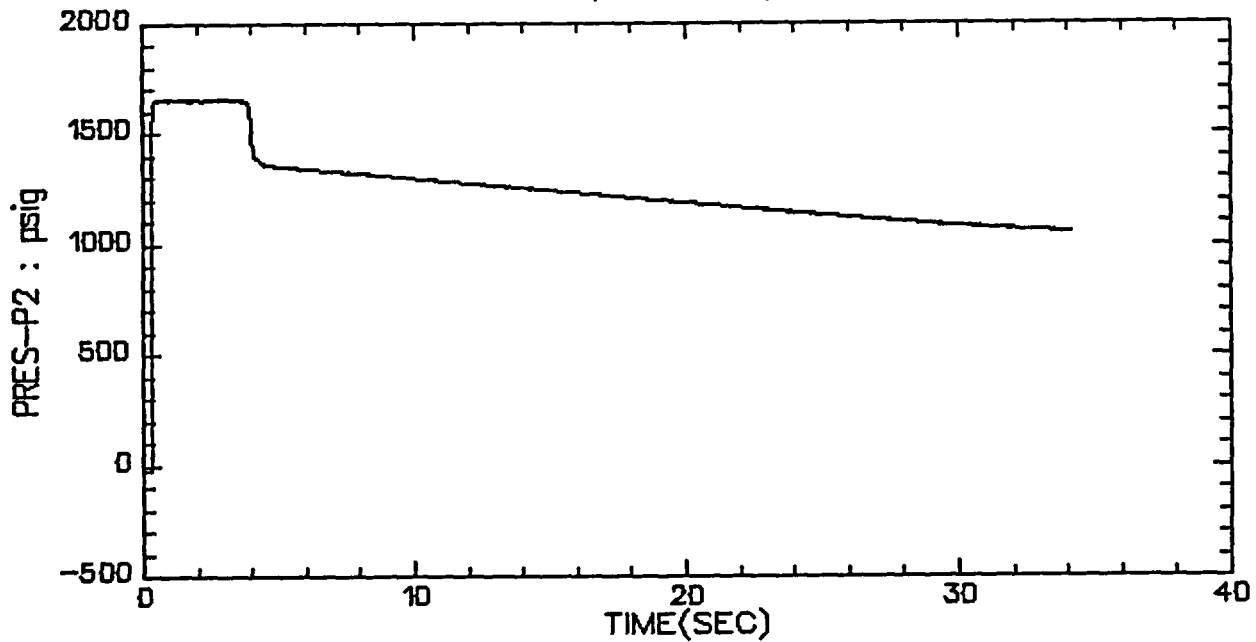

VALVE B, TEST 1, STEP 7

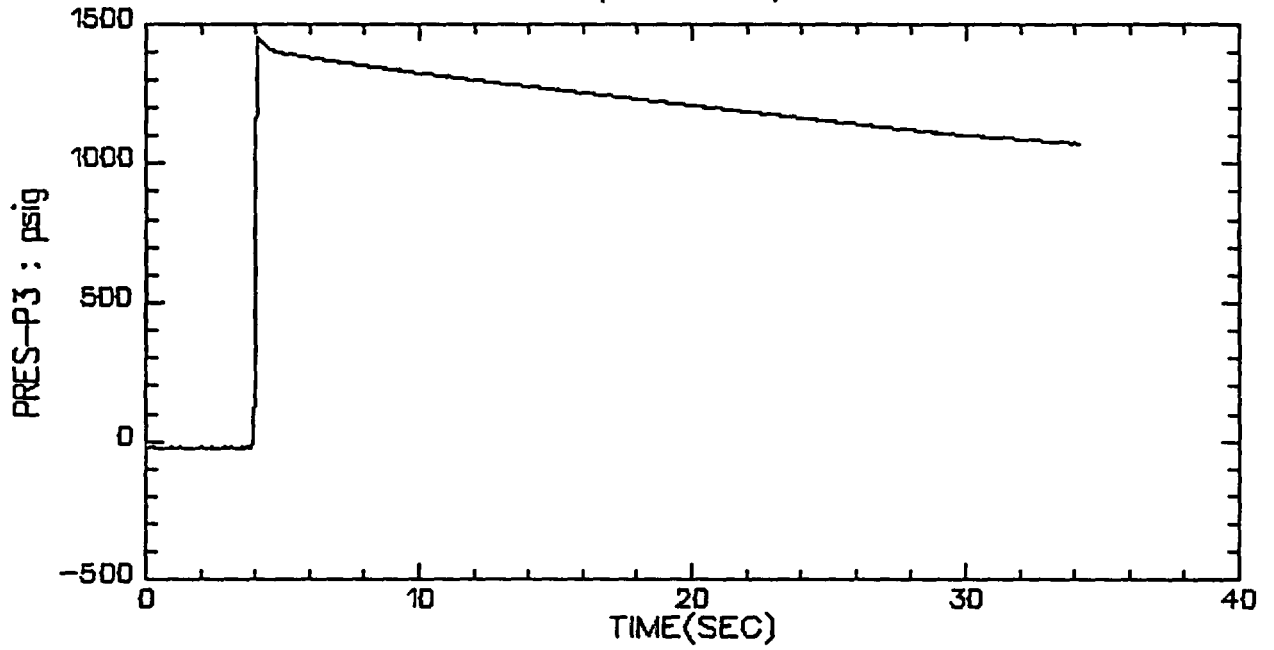

VALVE B, TEST 1, STEP 7

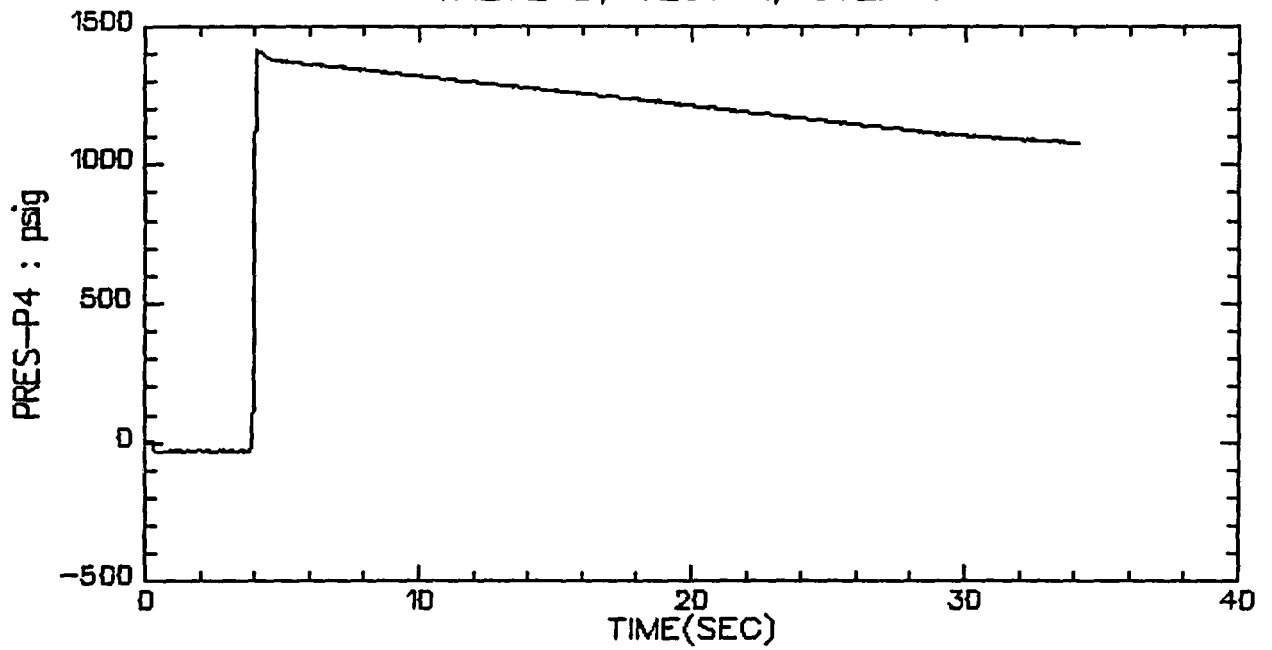

VALVE B, TEST 1, STEP 7

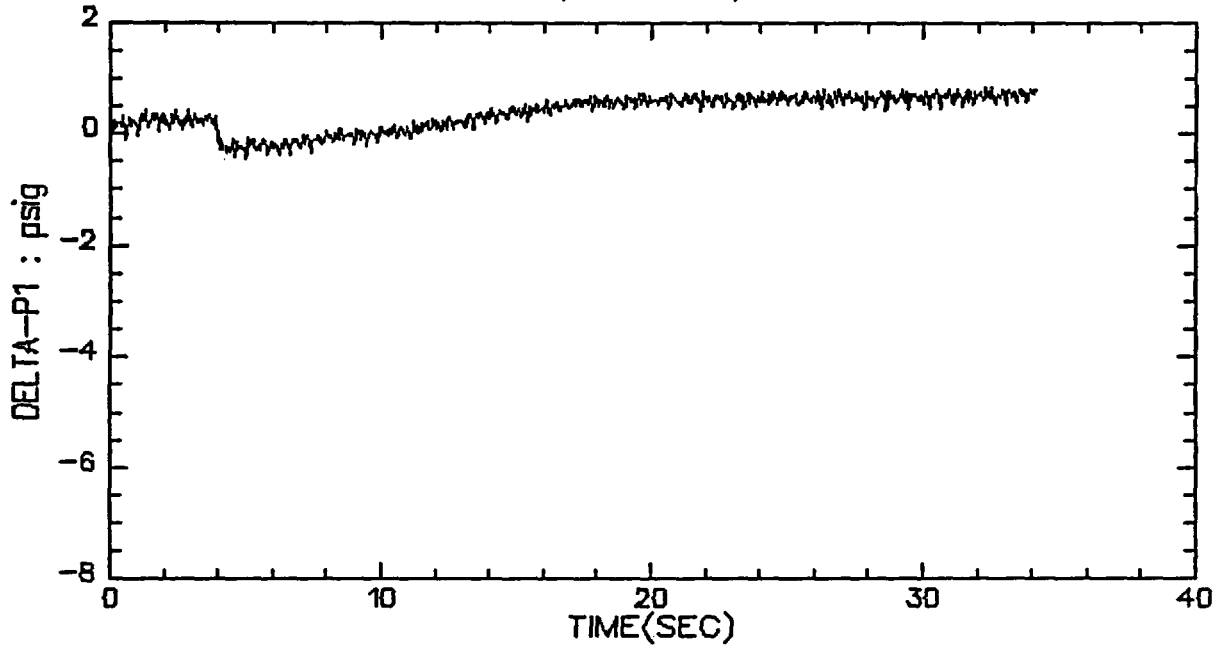

VALVE B, TEST 1, STEP 7

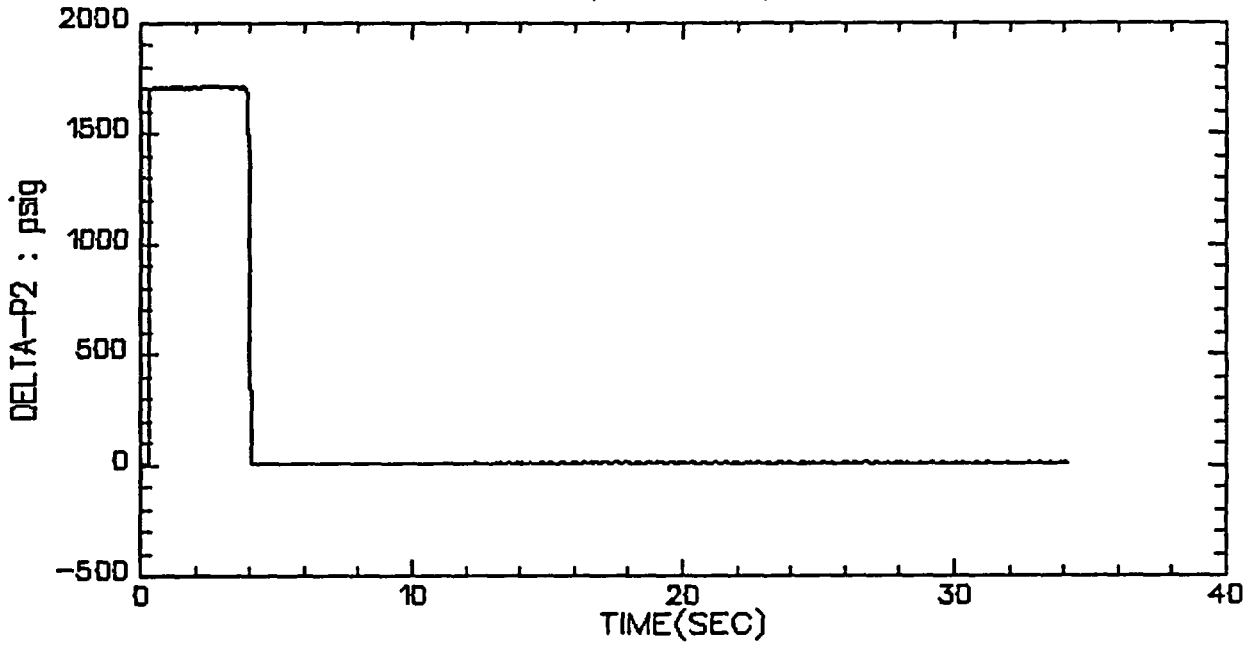

VALVE B, TEST 1, STEP 7

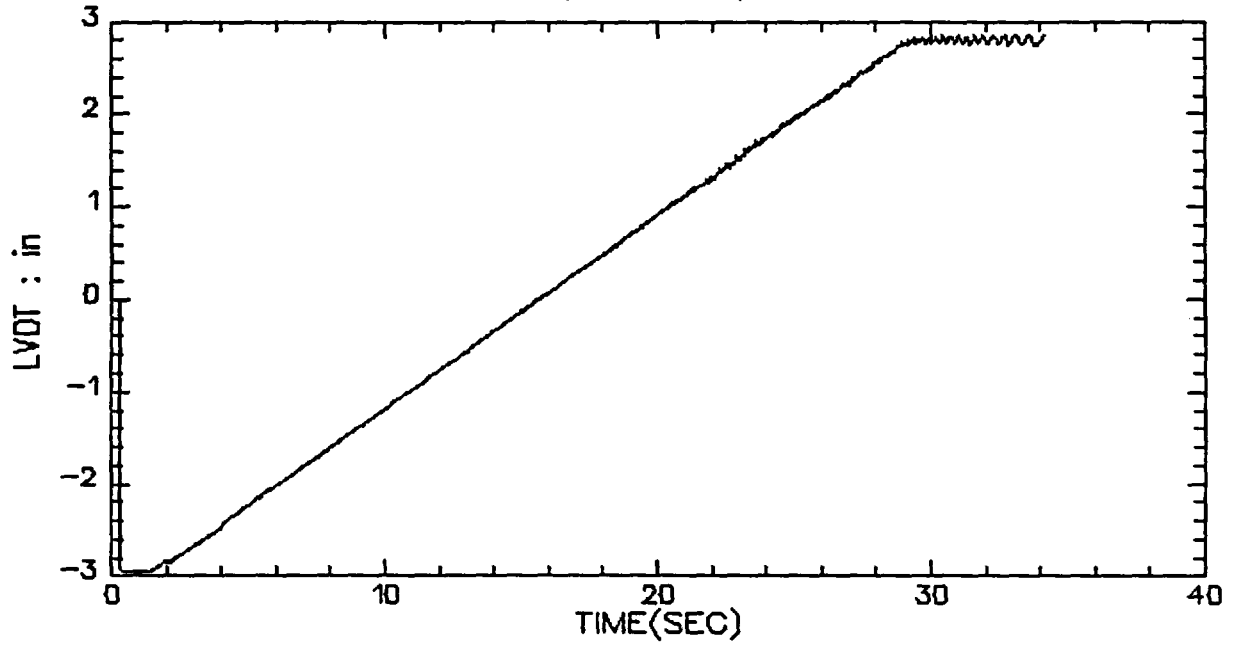

VALVE B, TEST 1, STEP 7

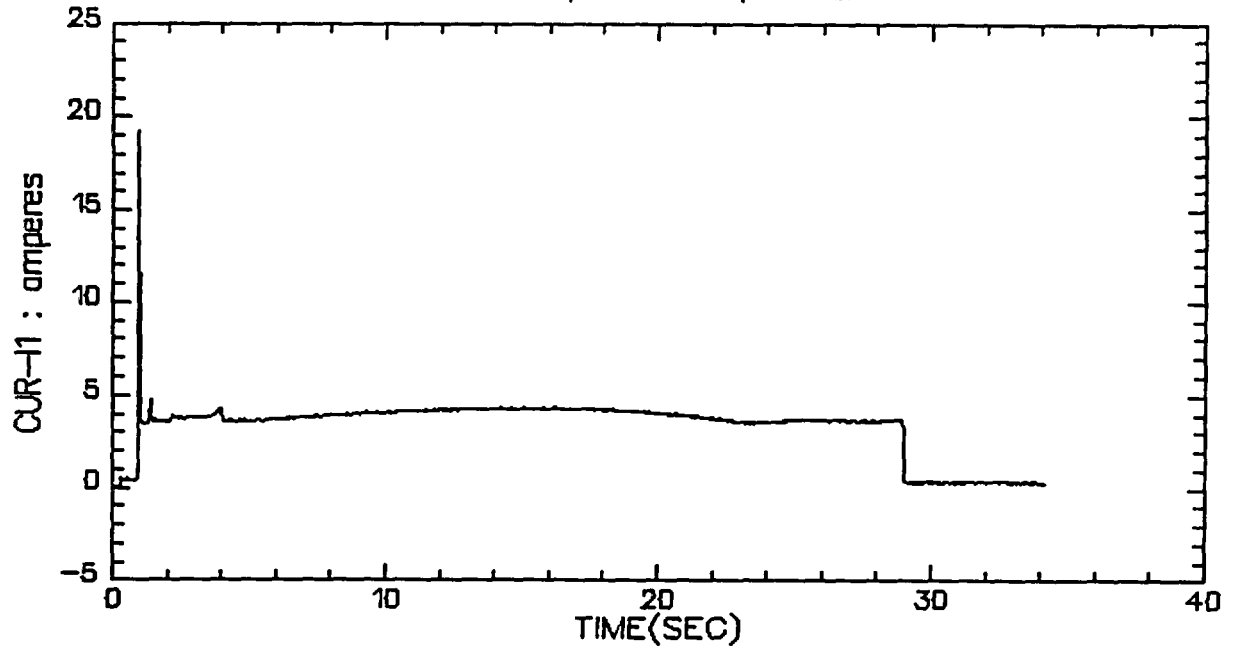

VALVE B, TEST 1, STEP 7

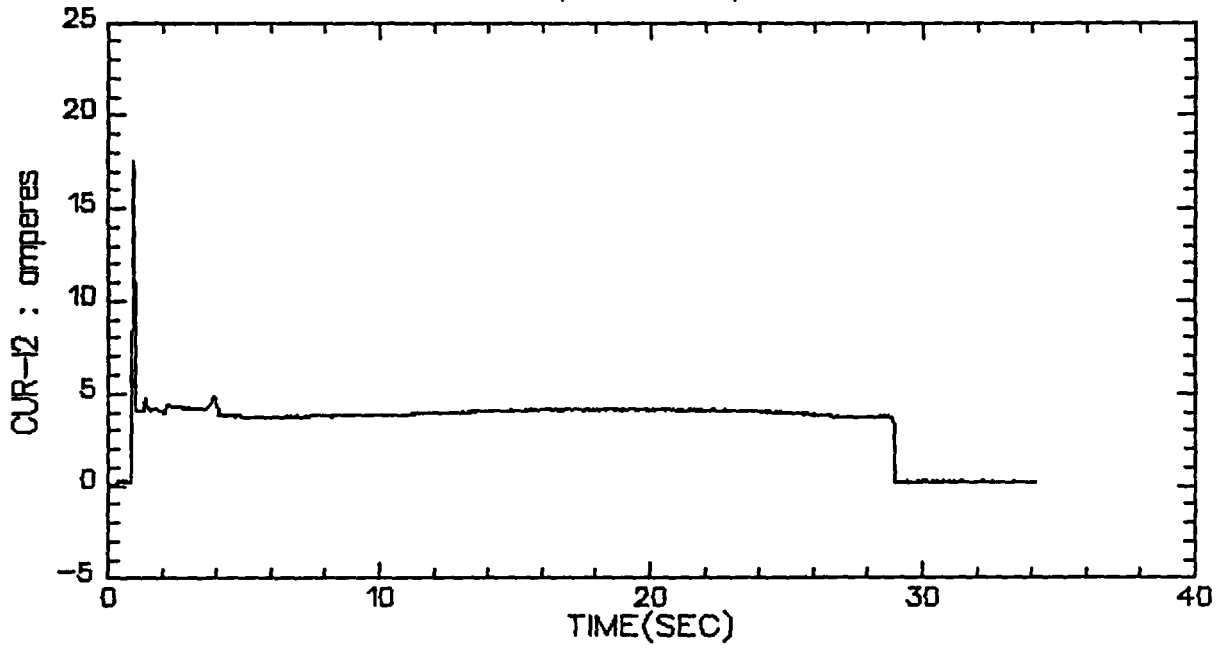

VALVE B, TEST 1, STEP 7

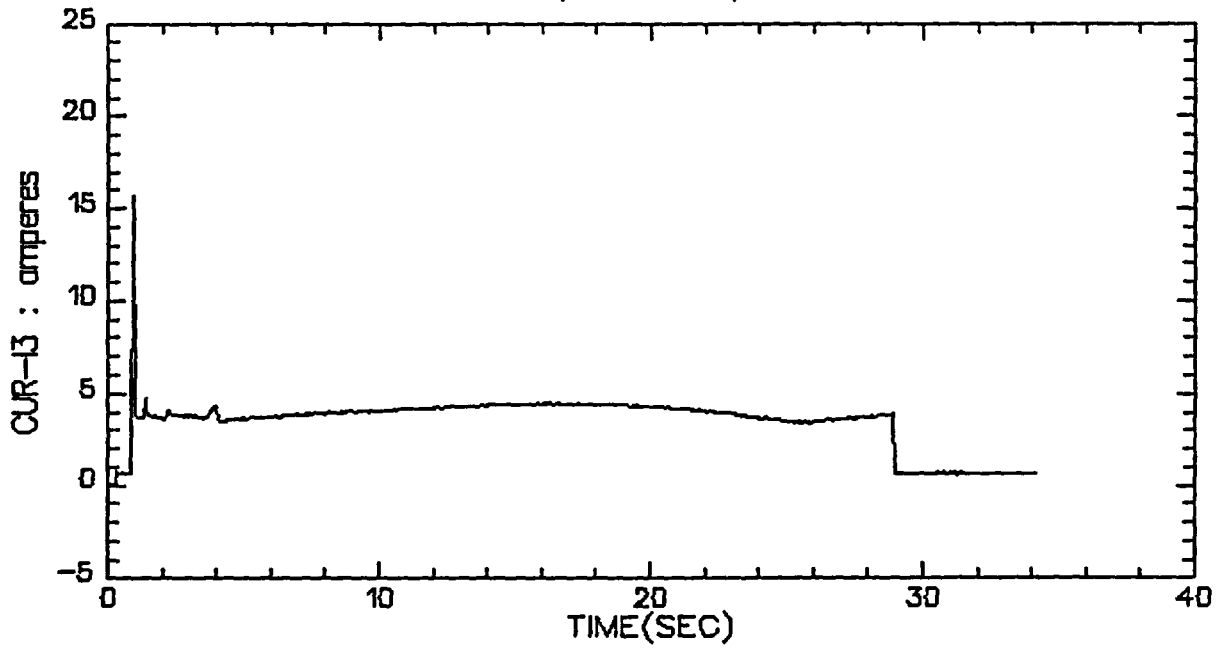

VALVE B, TEST 1, STEP 7

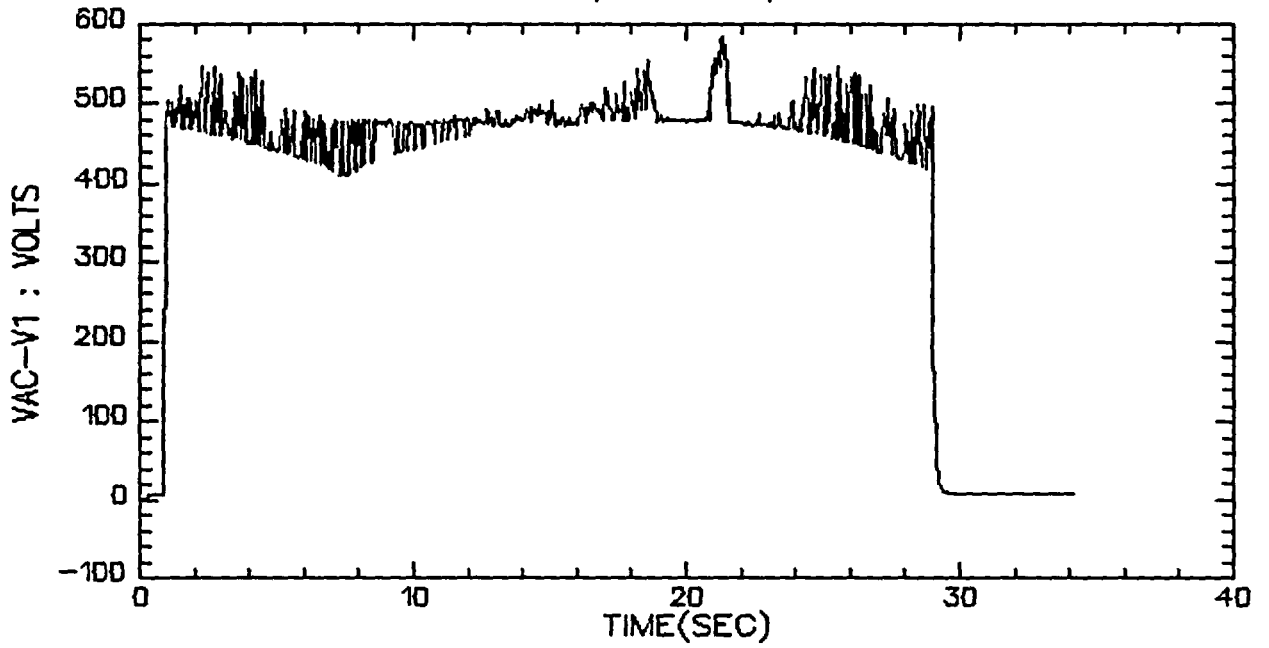

VALVE B, TEST 1, STEP 7

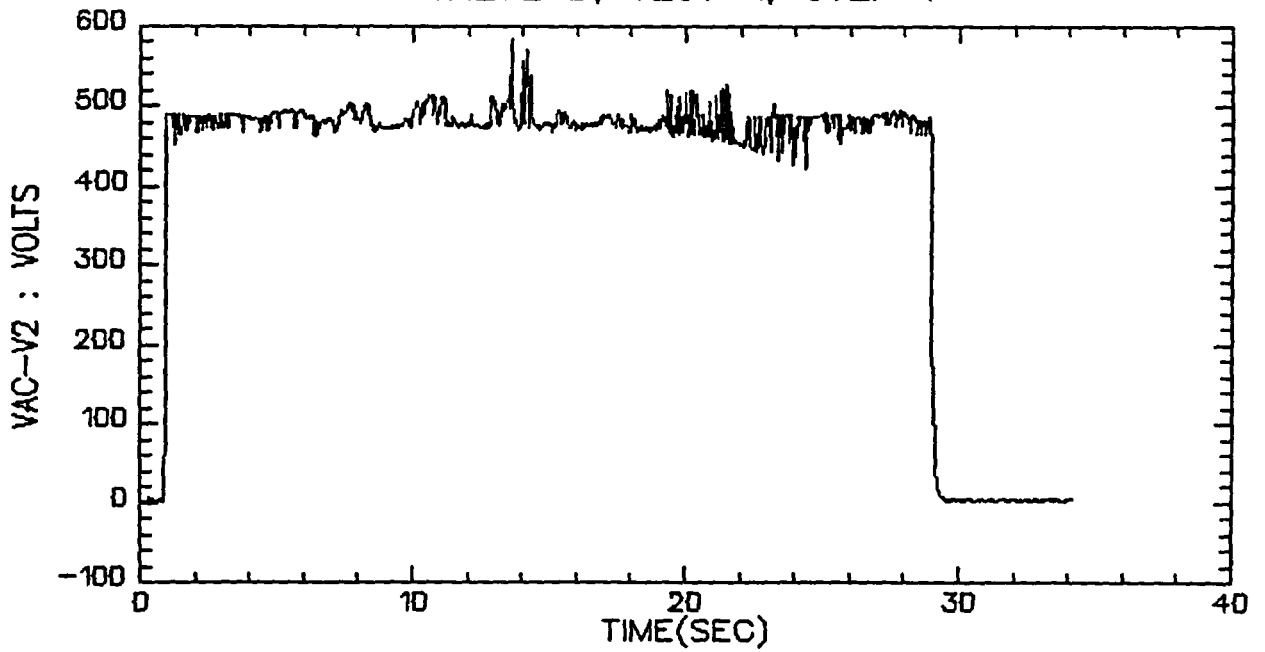

VALVE B, TEST 1, STEP 7

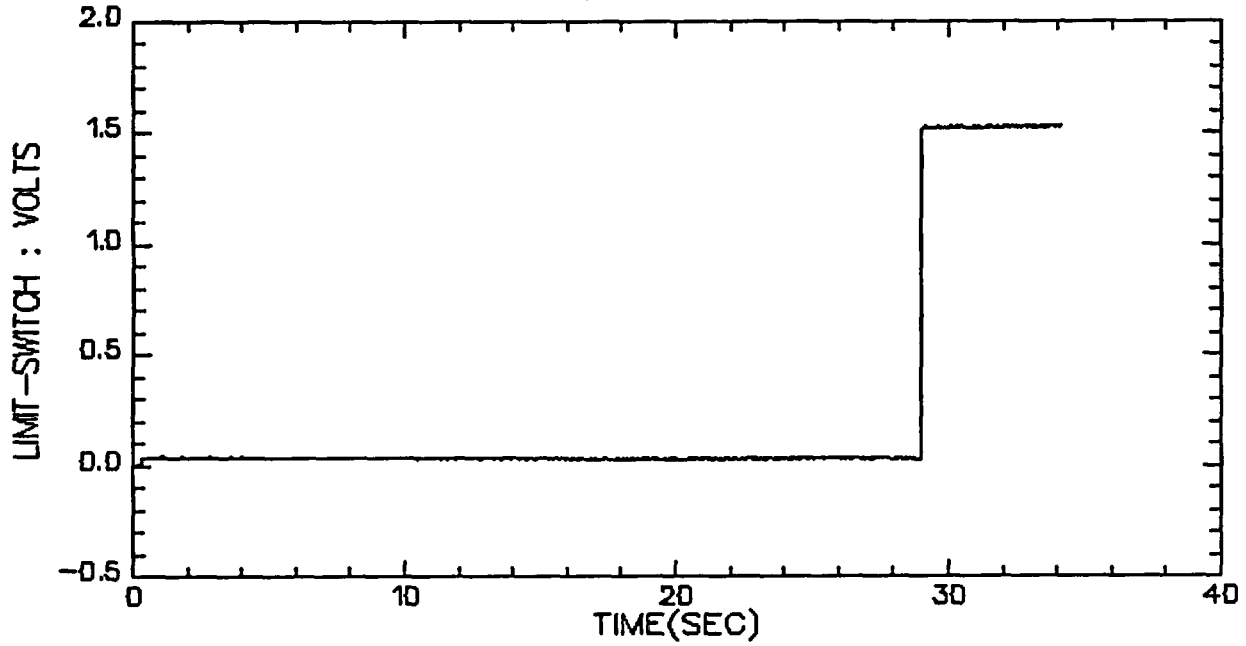

VALVE B, TEST 1, STEP 7

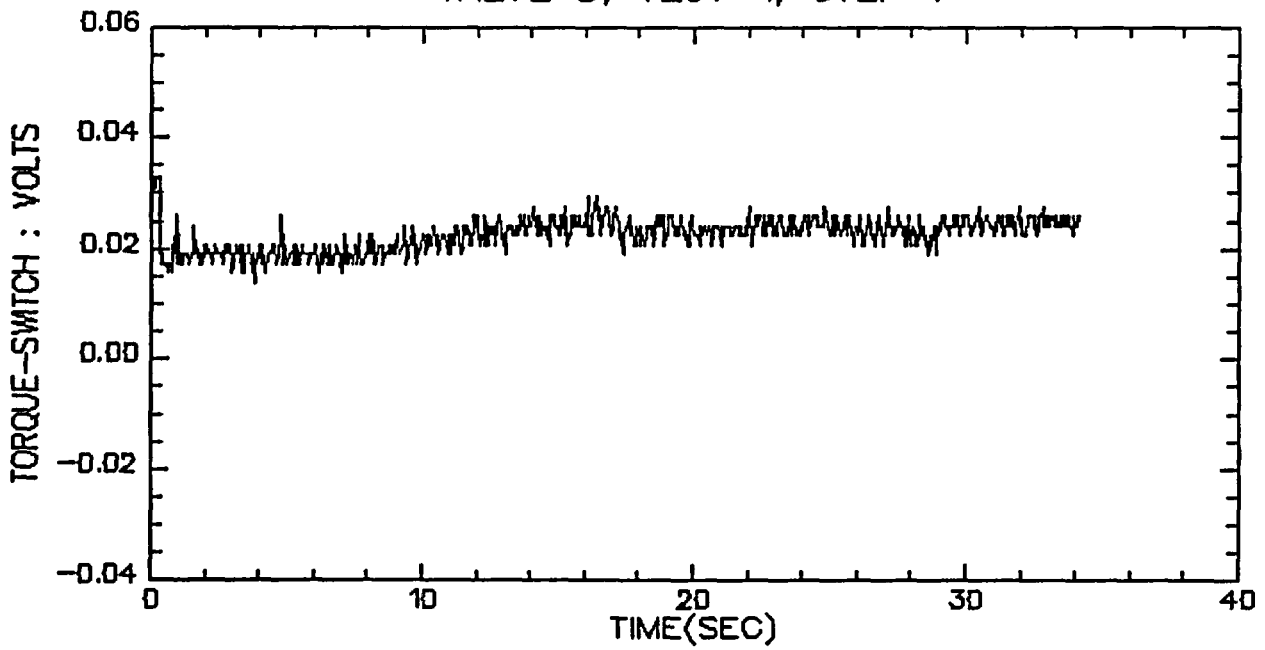

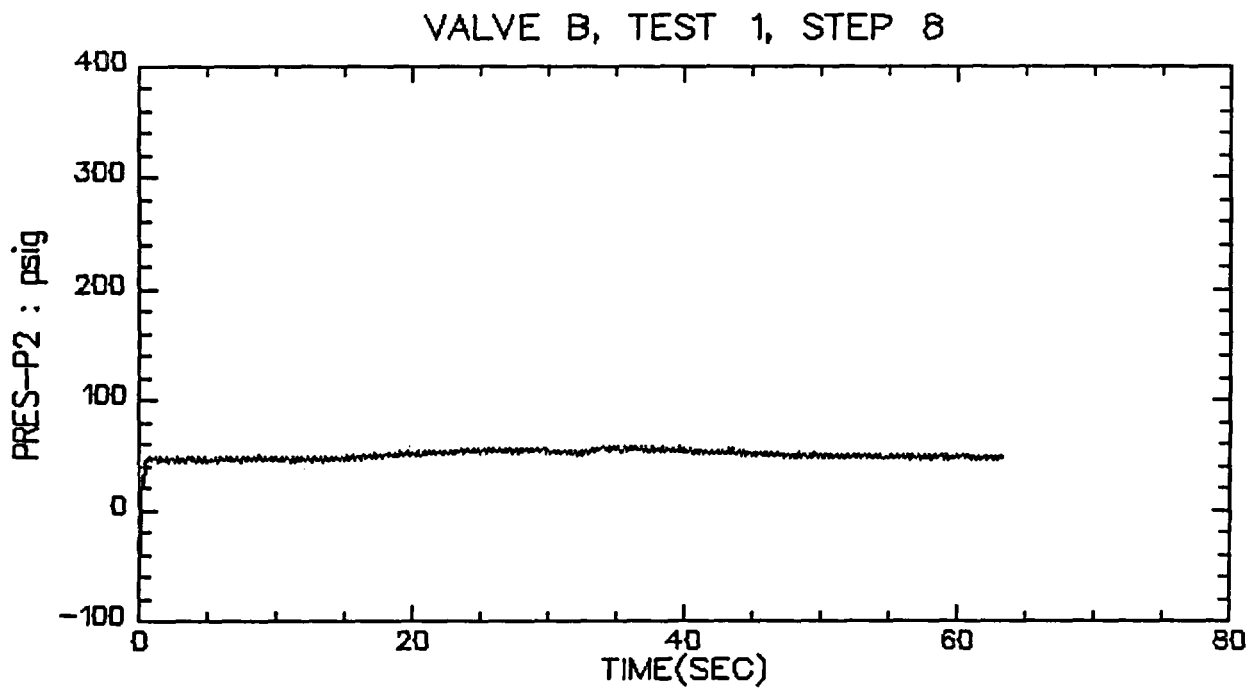
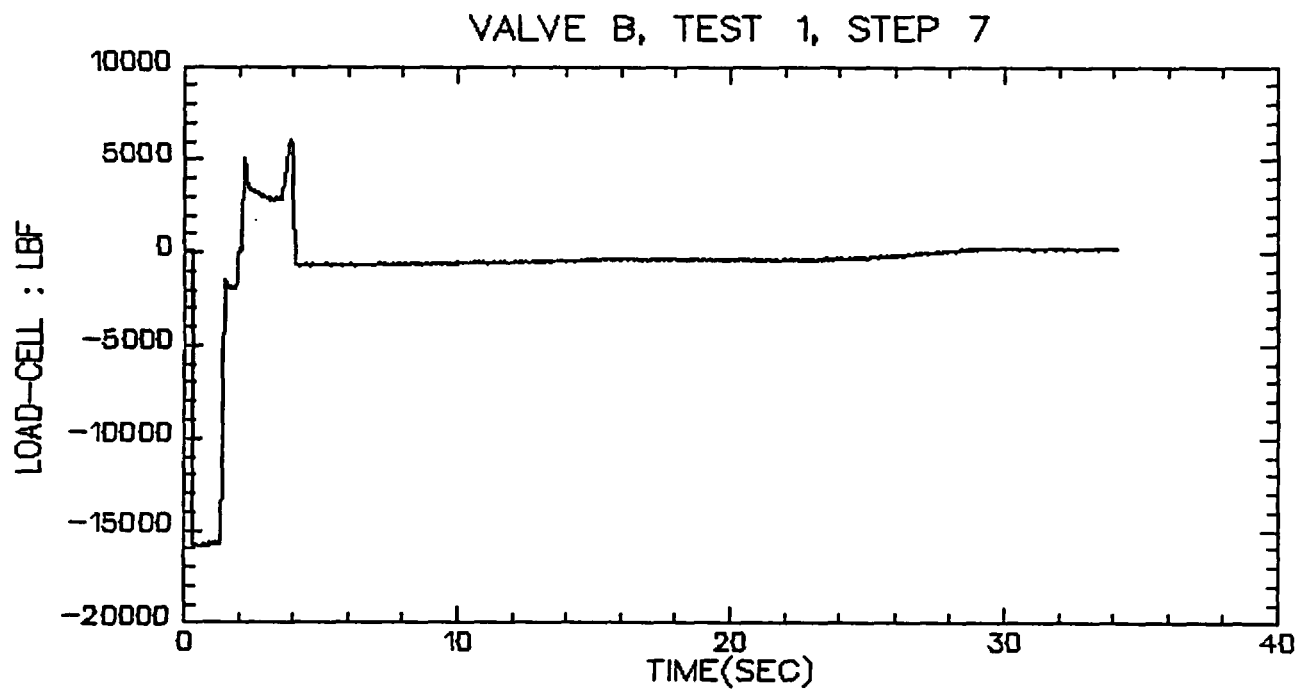

VALVE B, TEST 1, STEP 8

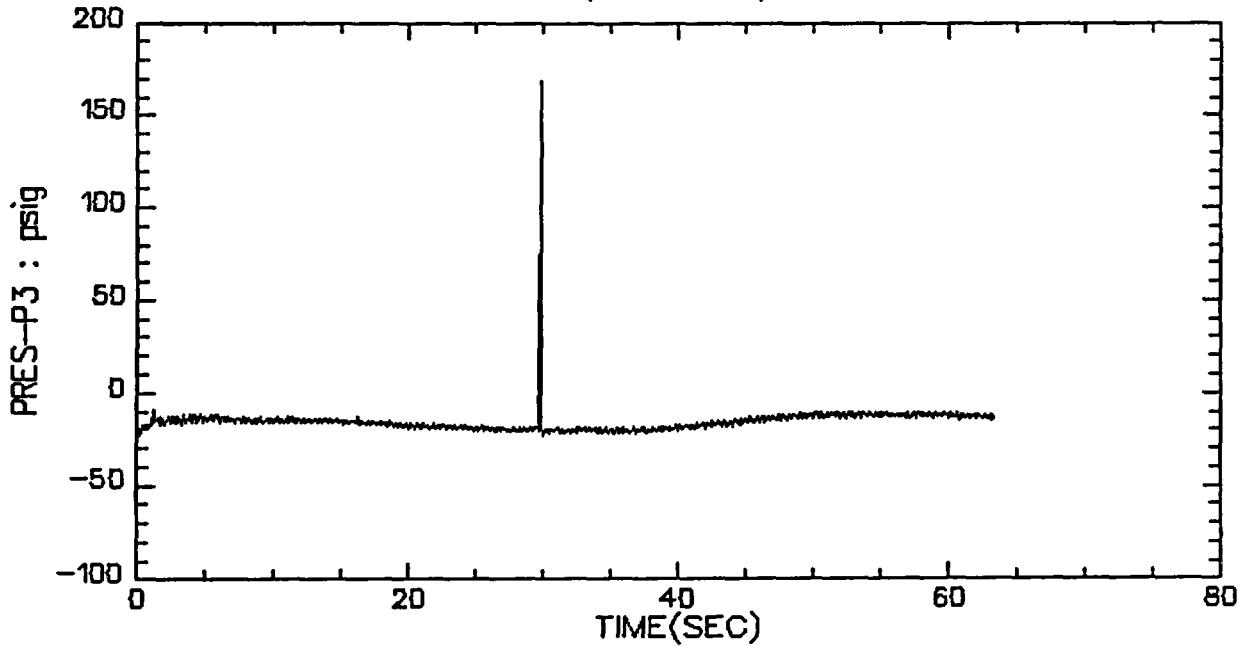

VALVE B, TEST 1, STEP 8

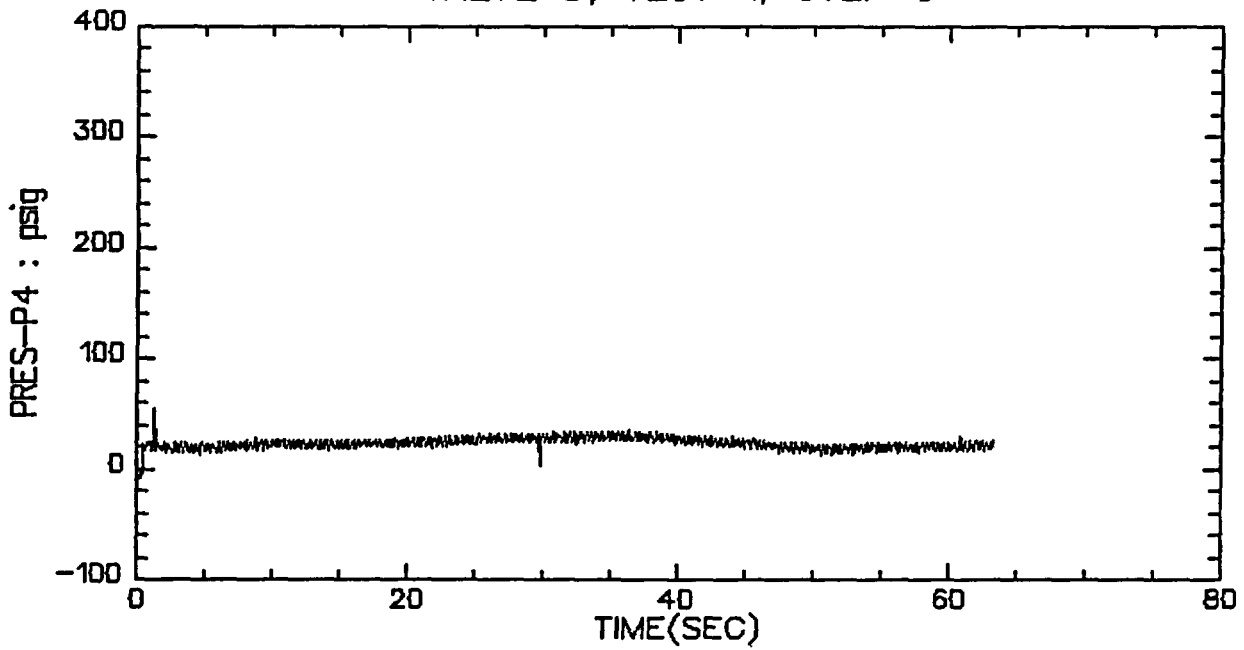

VALVE B, TEST 1, STEP 8

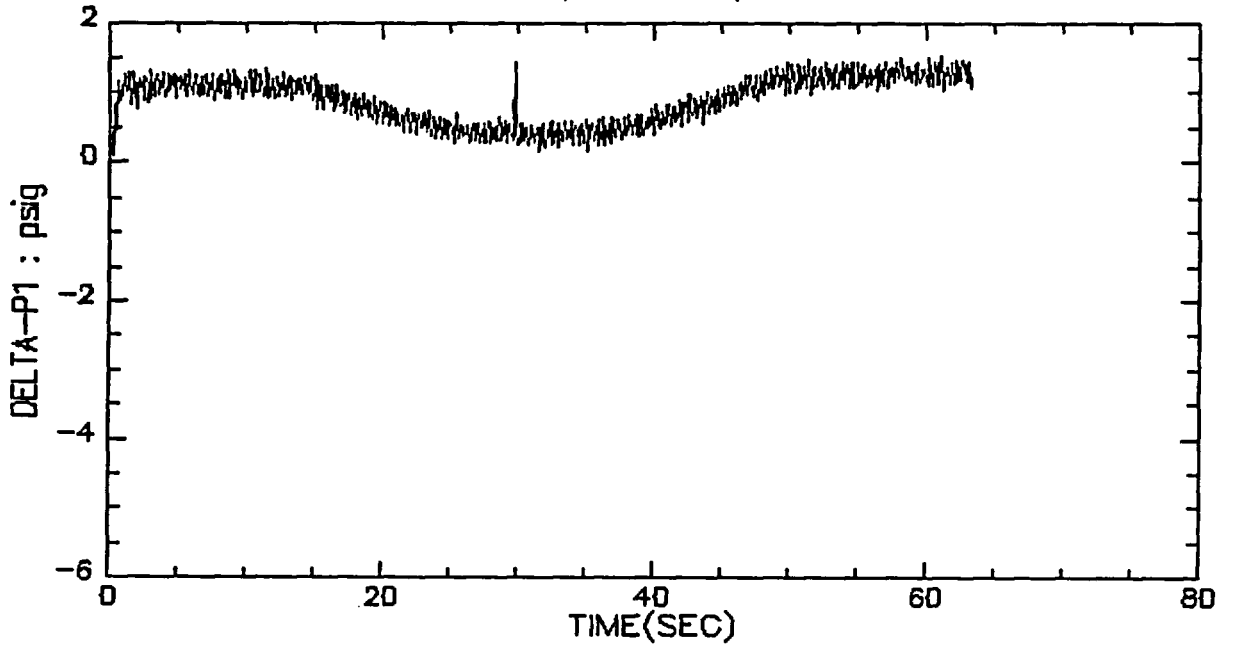

VALVE B, TEST 1, STEP 8

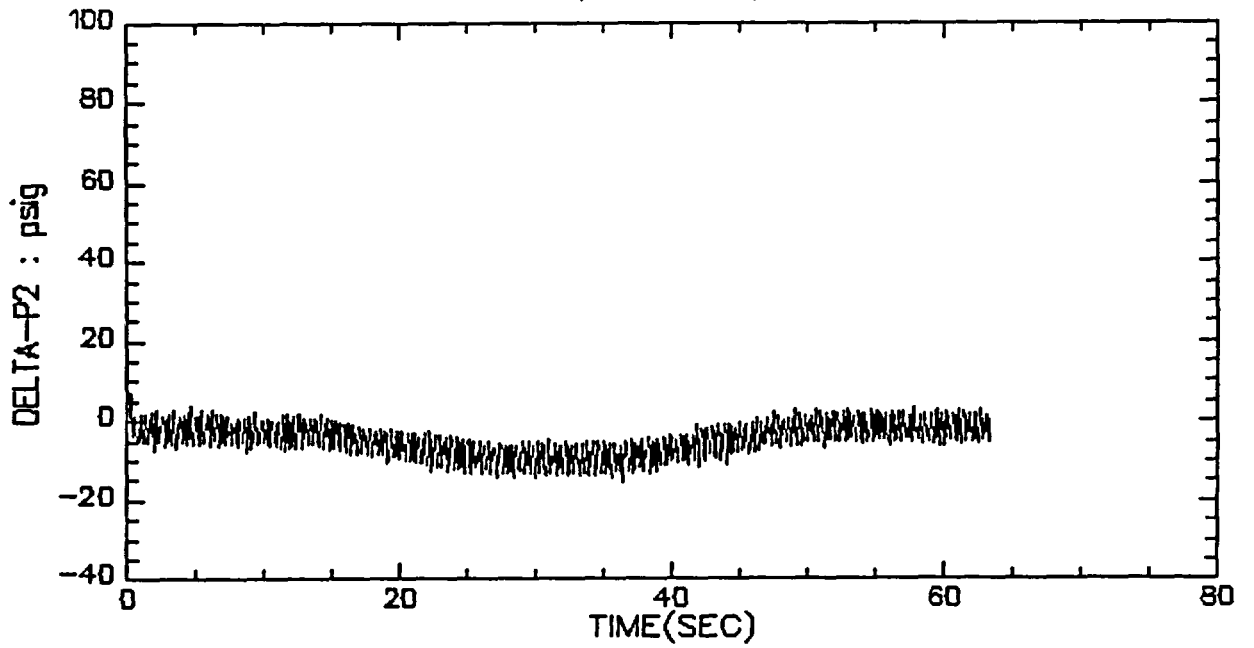

VALVE B, TEST 1, STEP 8

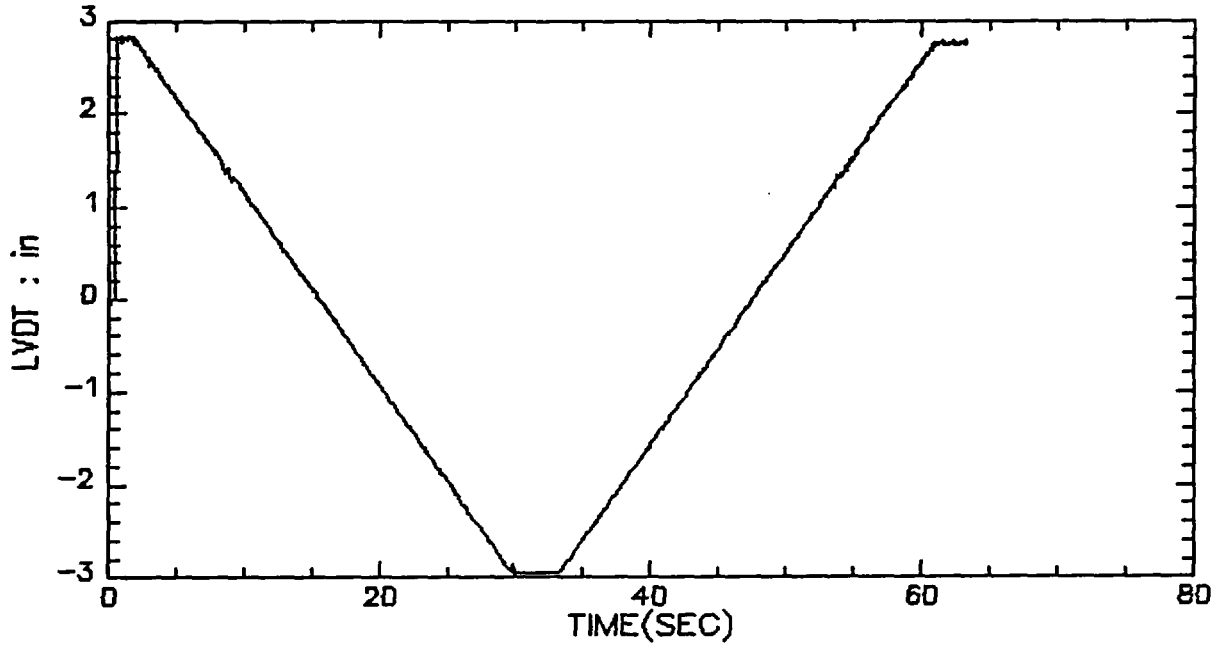

VALVE B, TEST 1, STEP 8

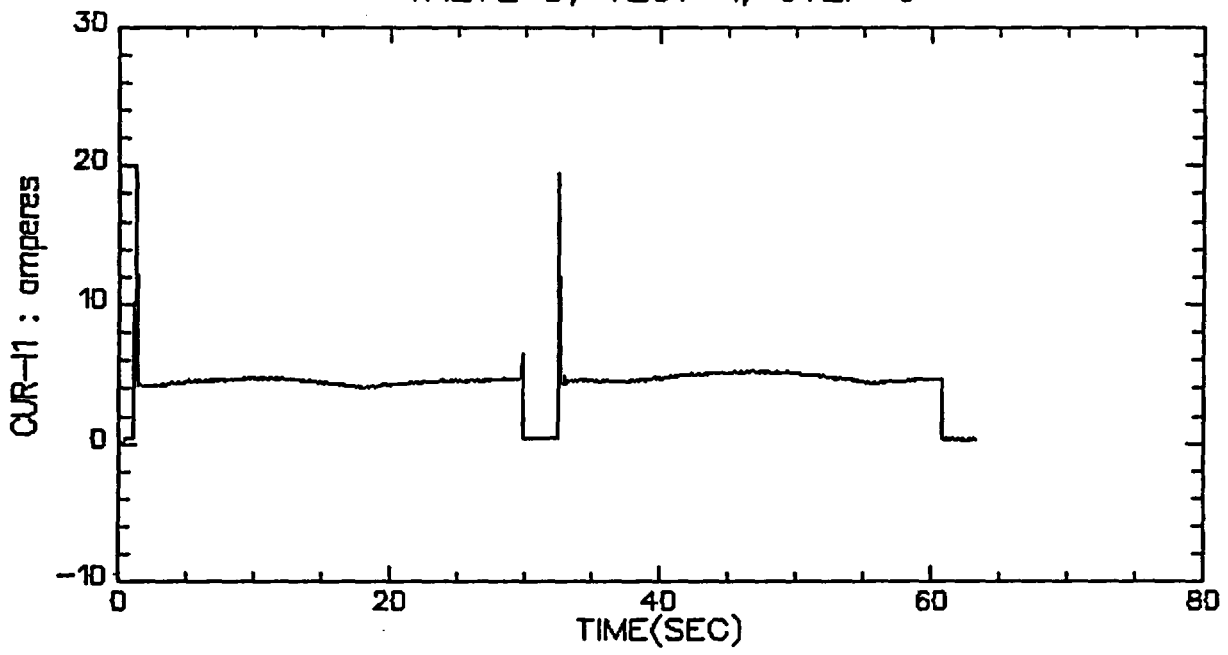

VALVE B, TEST 1, STEP 8

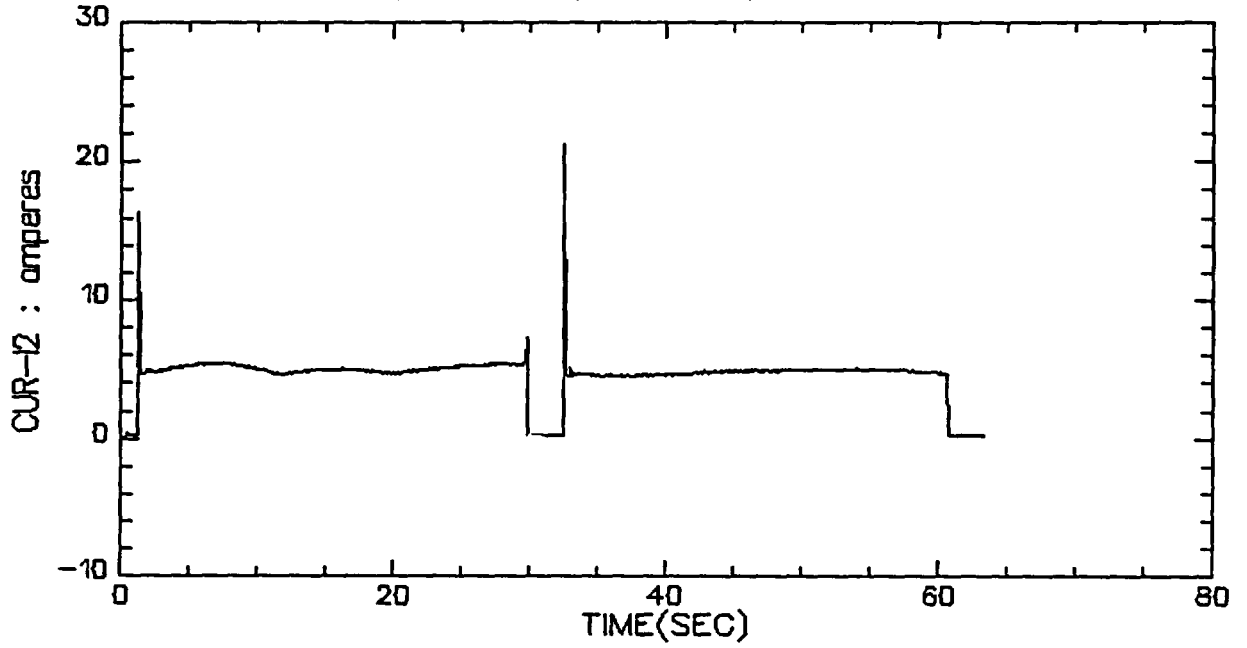

VALVE B, TEST 1, STEP 8

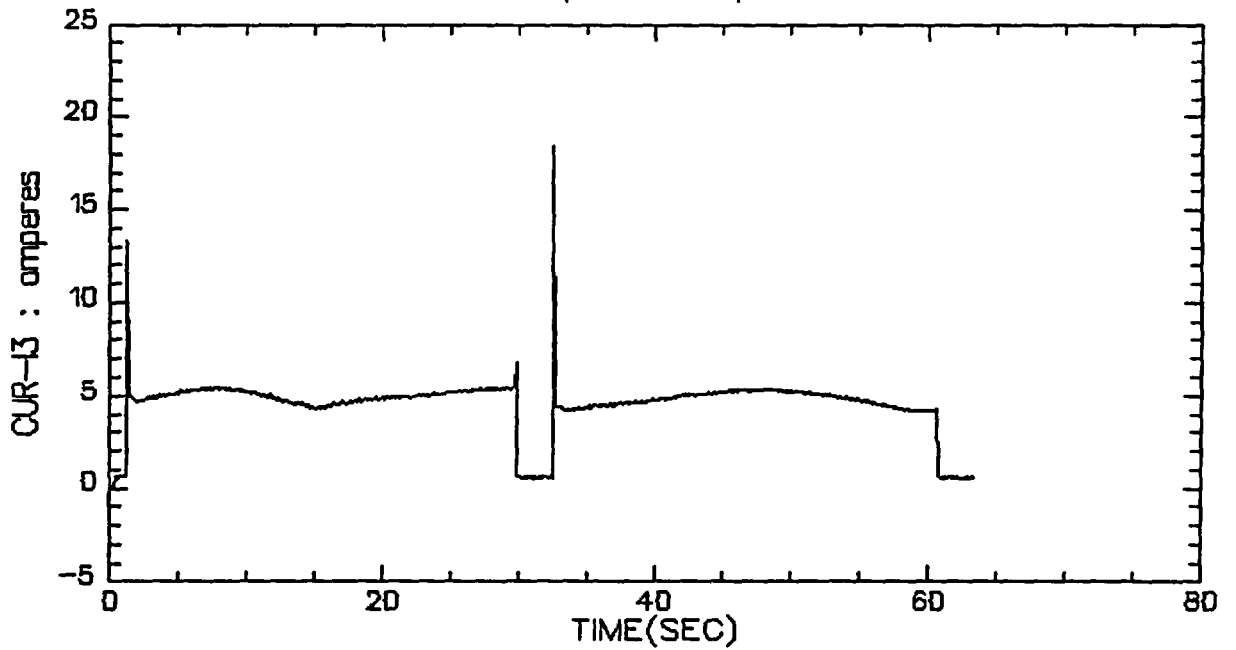

VALVE B, TEST 1, STEP 8

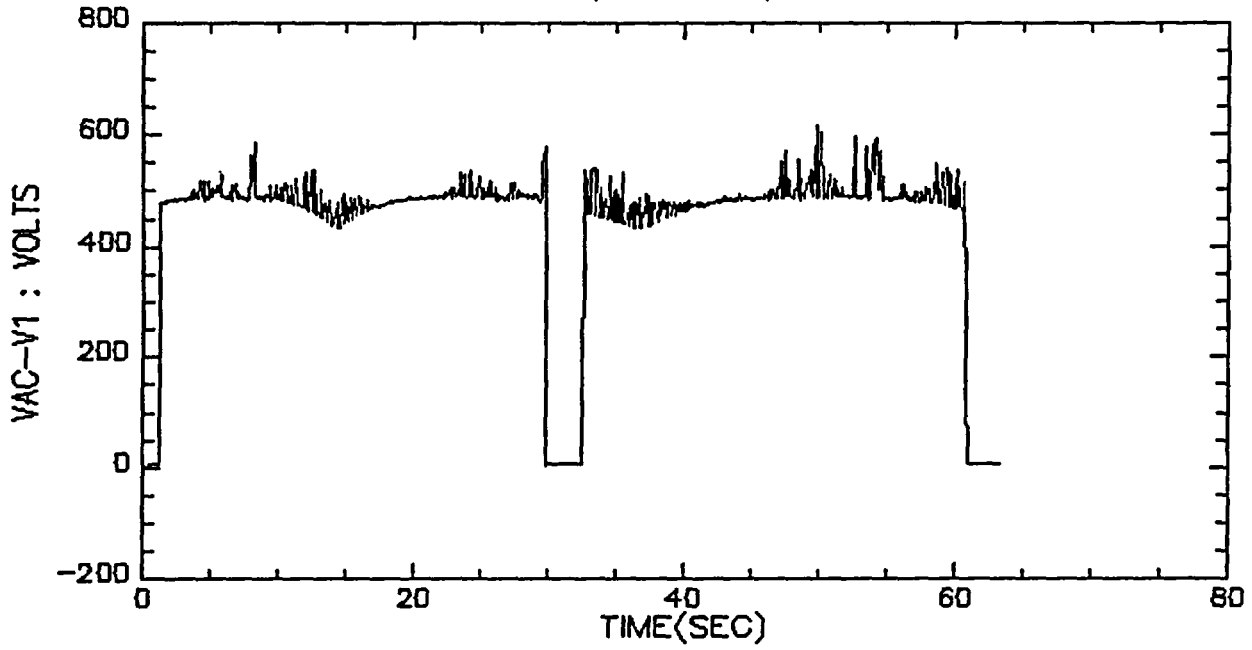

VALVE B, TEST 1, STEP 8

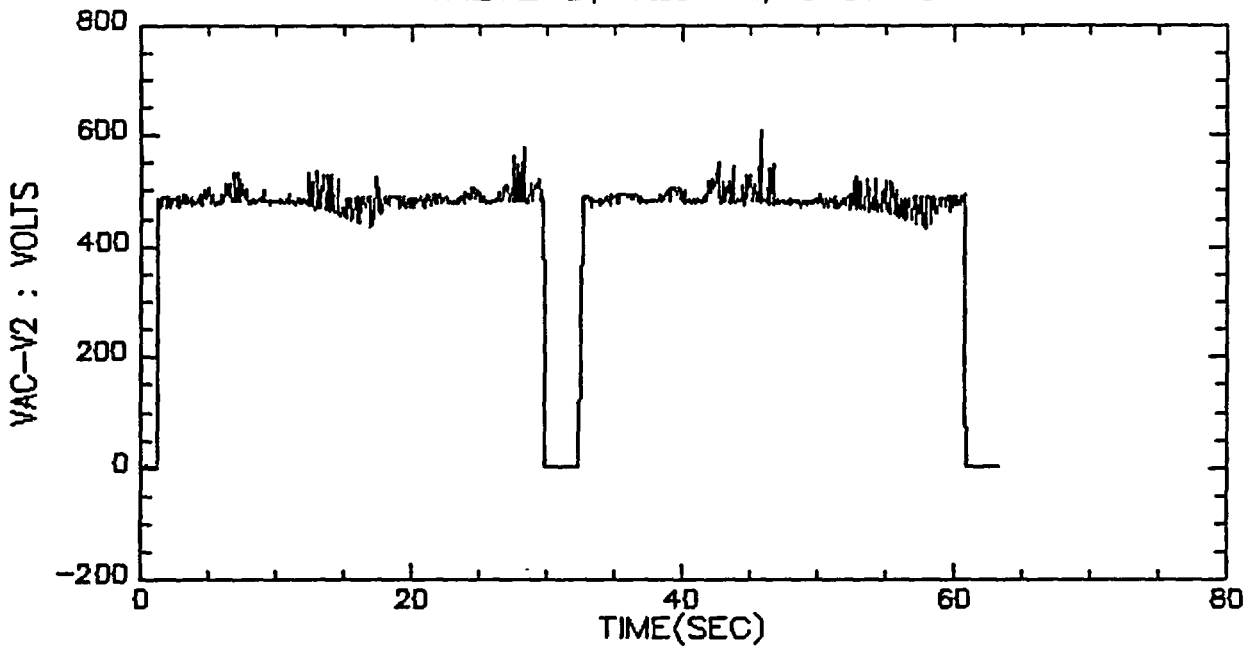

VALVE B, TEST 1, STEP 8

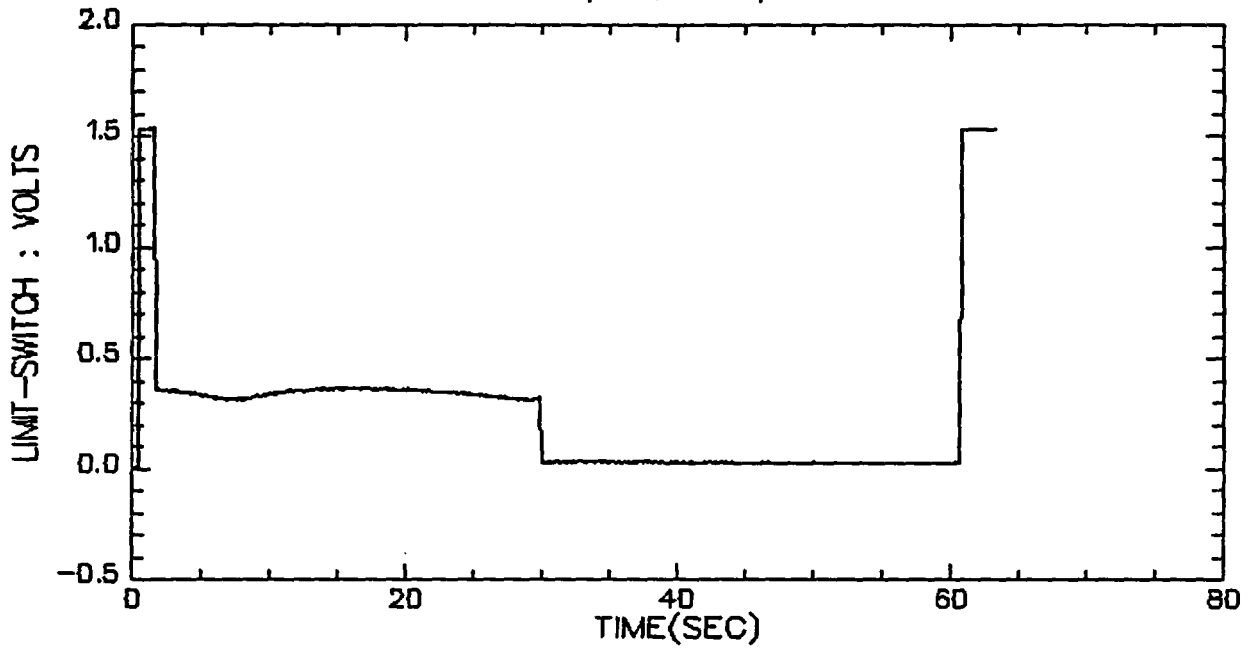

VALVE B, TEST 1, STEP 8

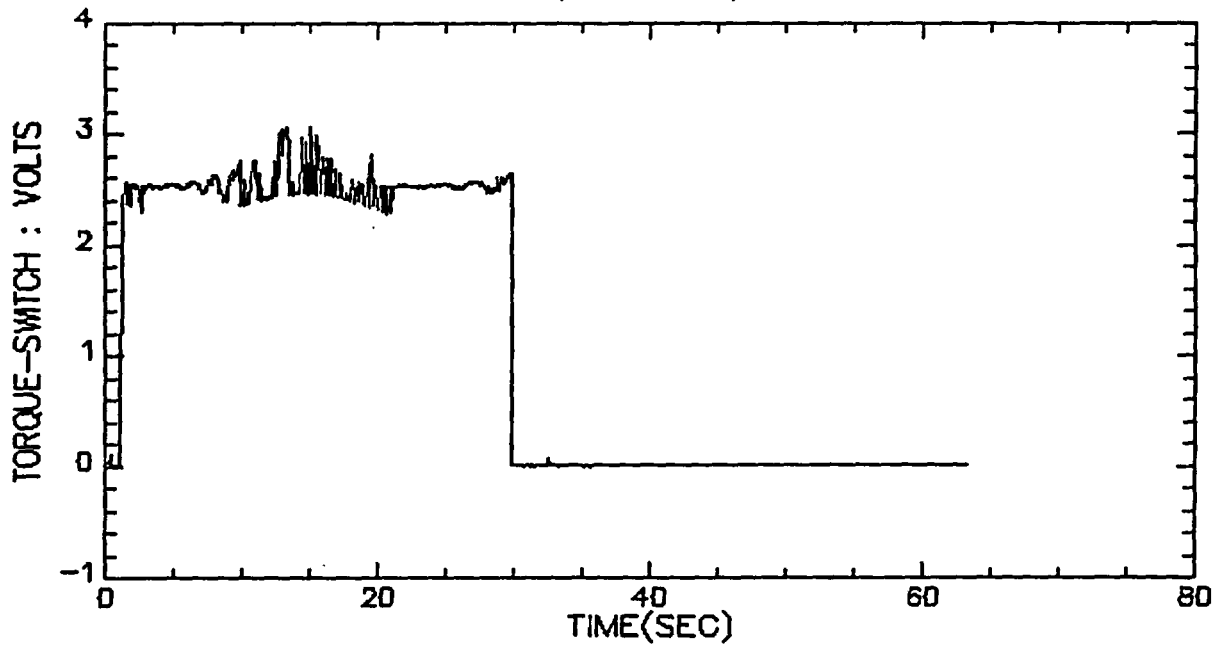

VALVE B, TEST 1, STEP 8

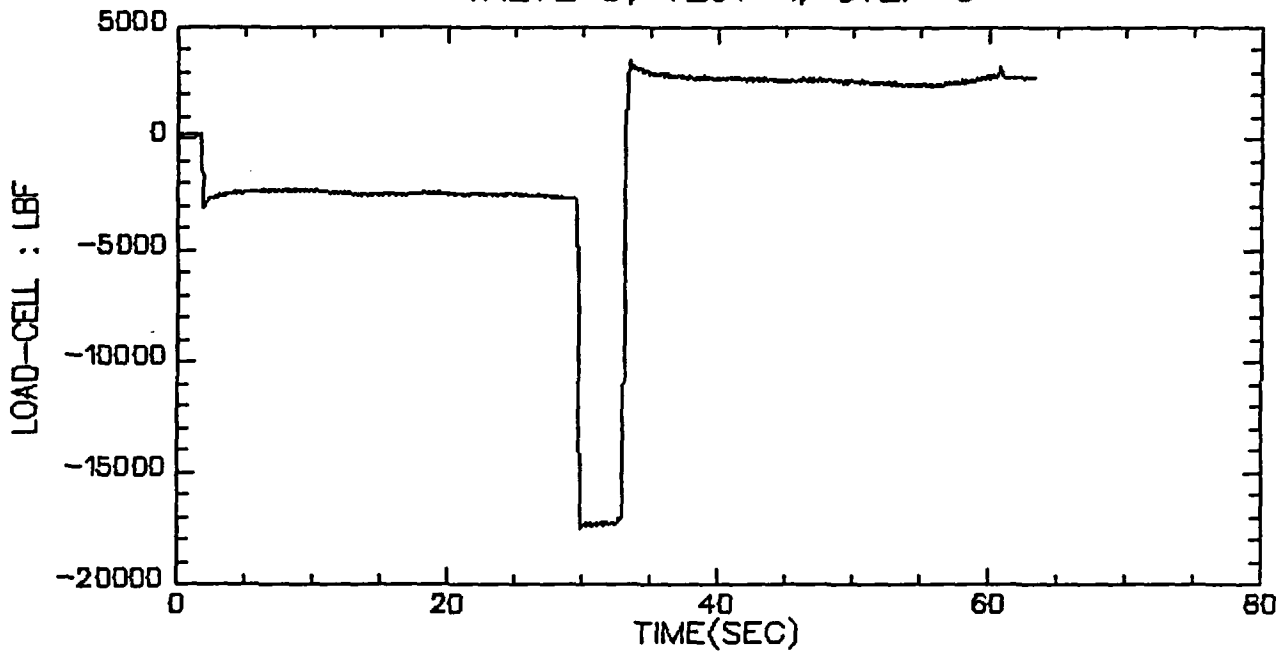

VALVE B, TEST 1, STEP 9

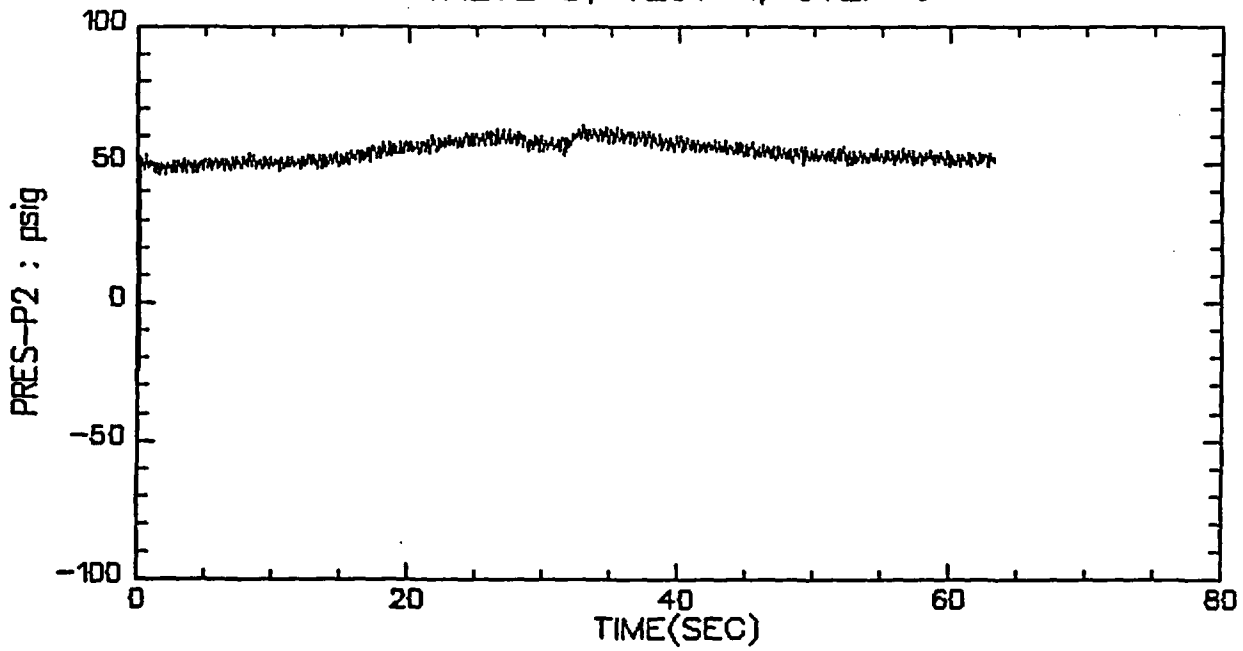

VALVE B, TEST 1, STEP 9

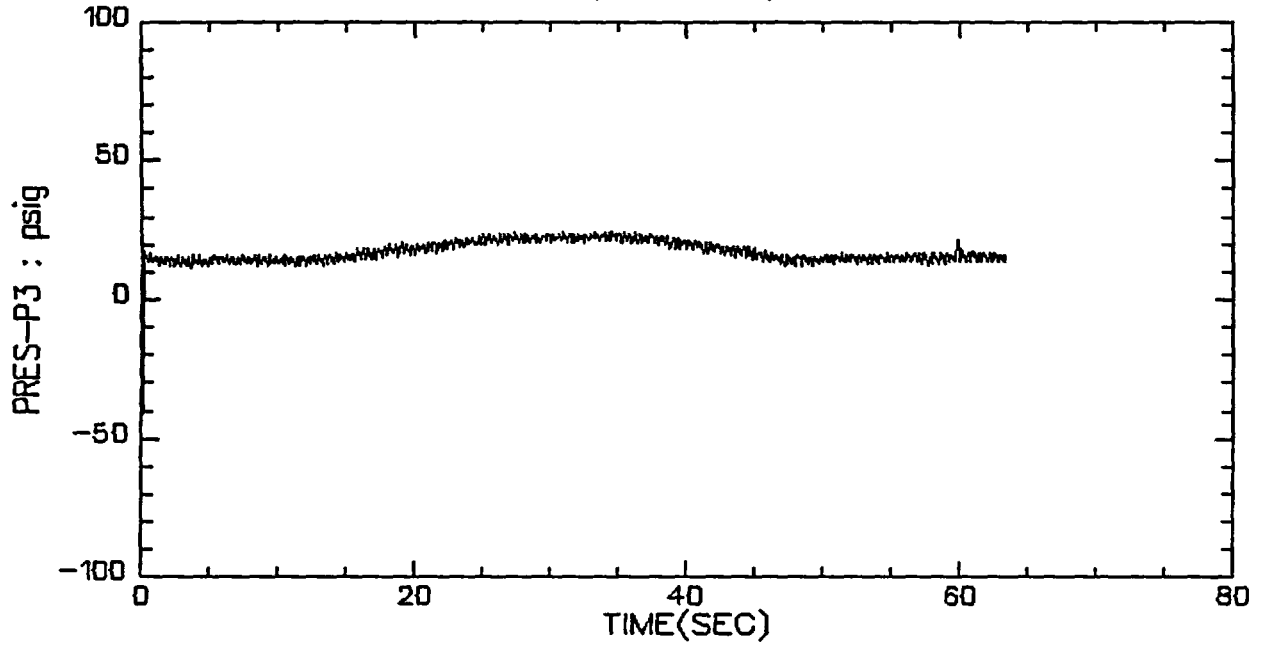

VALVE B, TEST 1, STEP 9

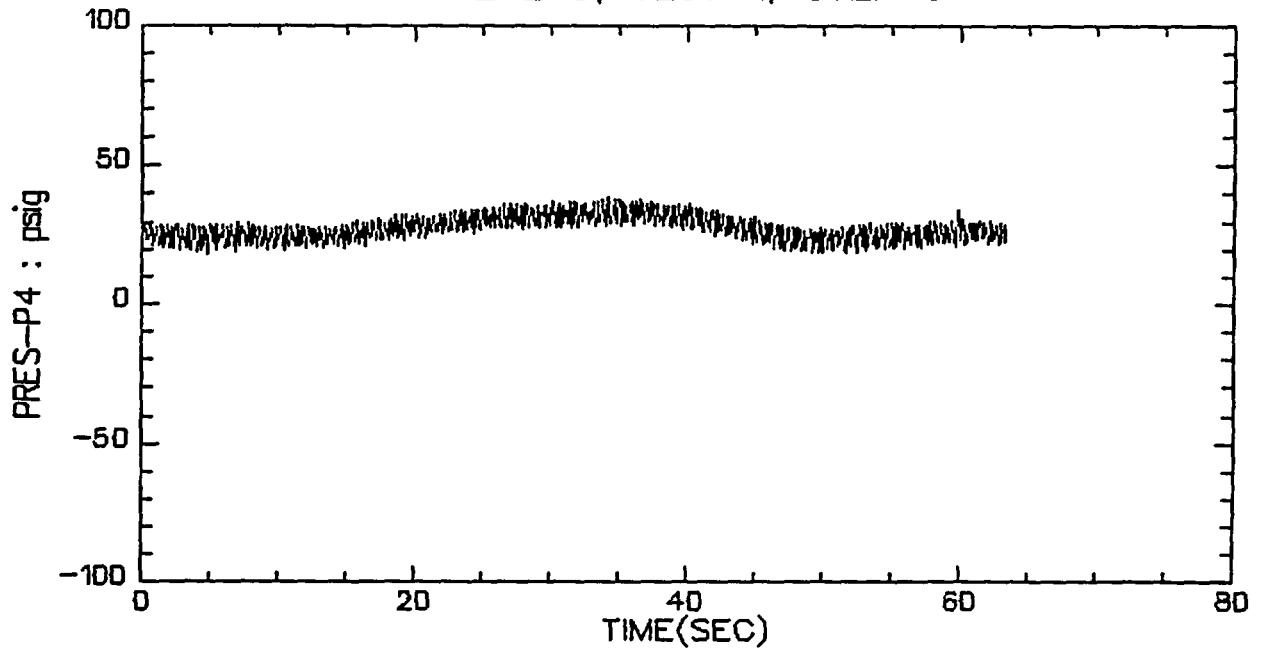

VALVE B, TEST 1, STEP 9

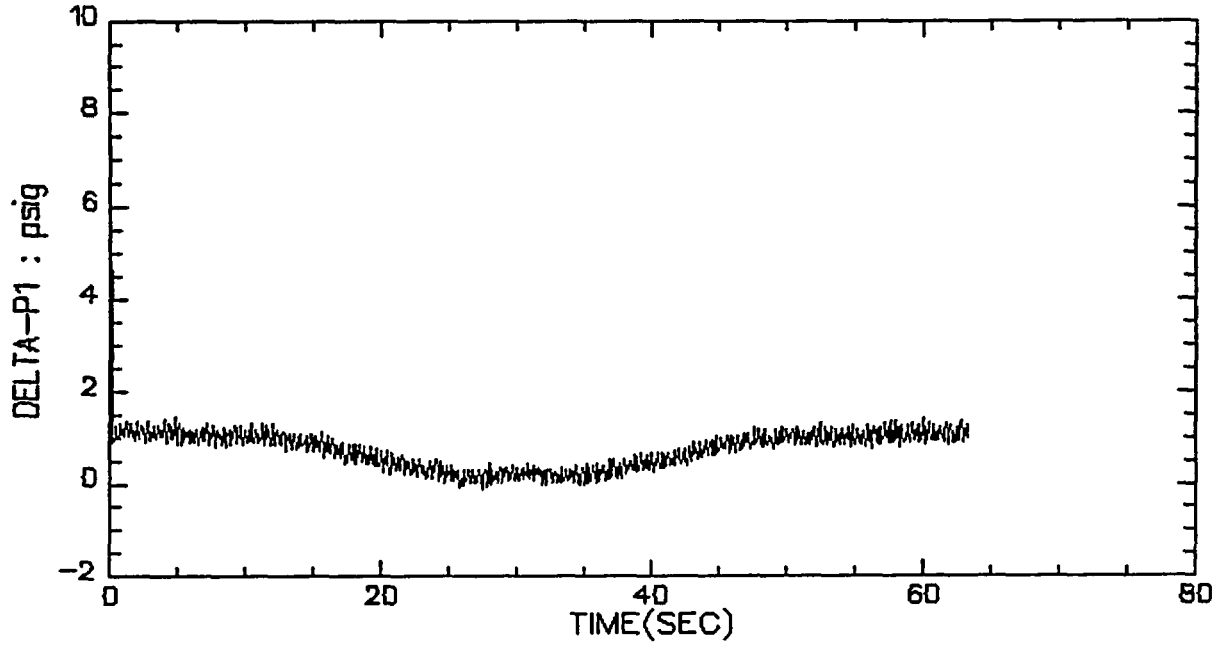

VALVE B, TEST 1, STEP 9

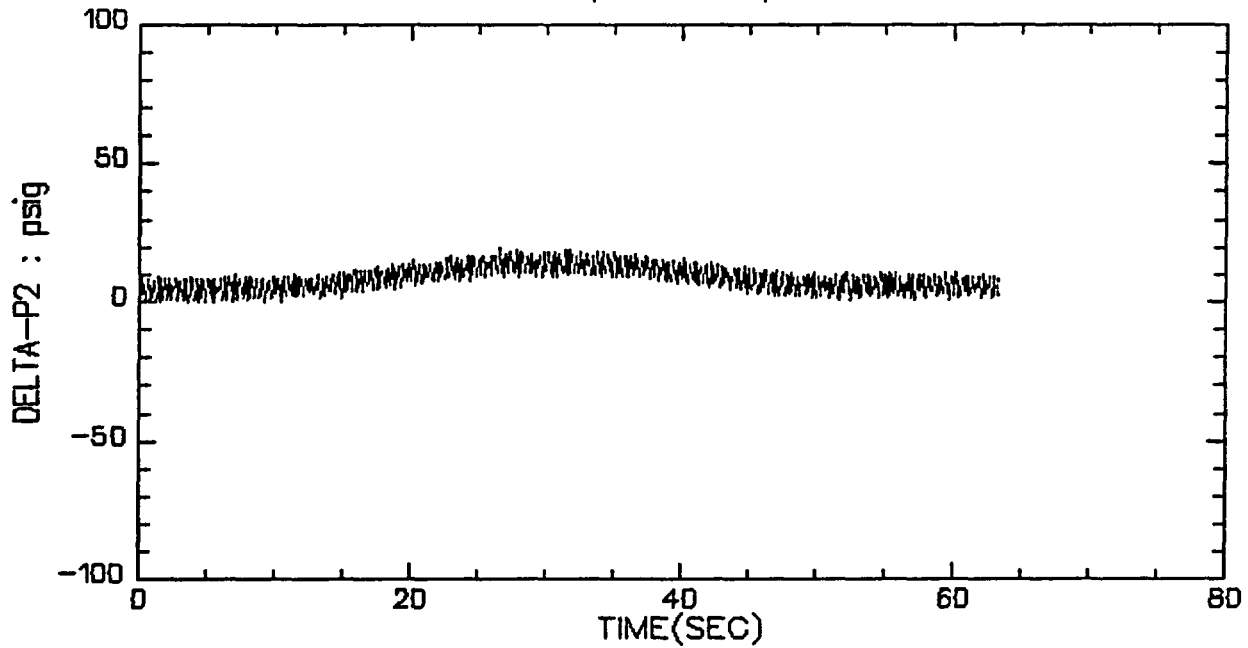

VALVE B, TEST 1, STEP 9

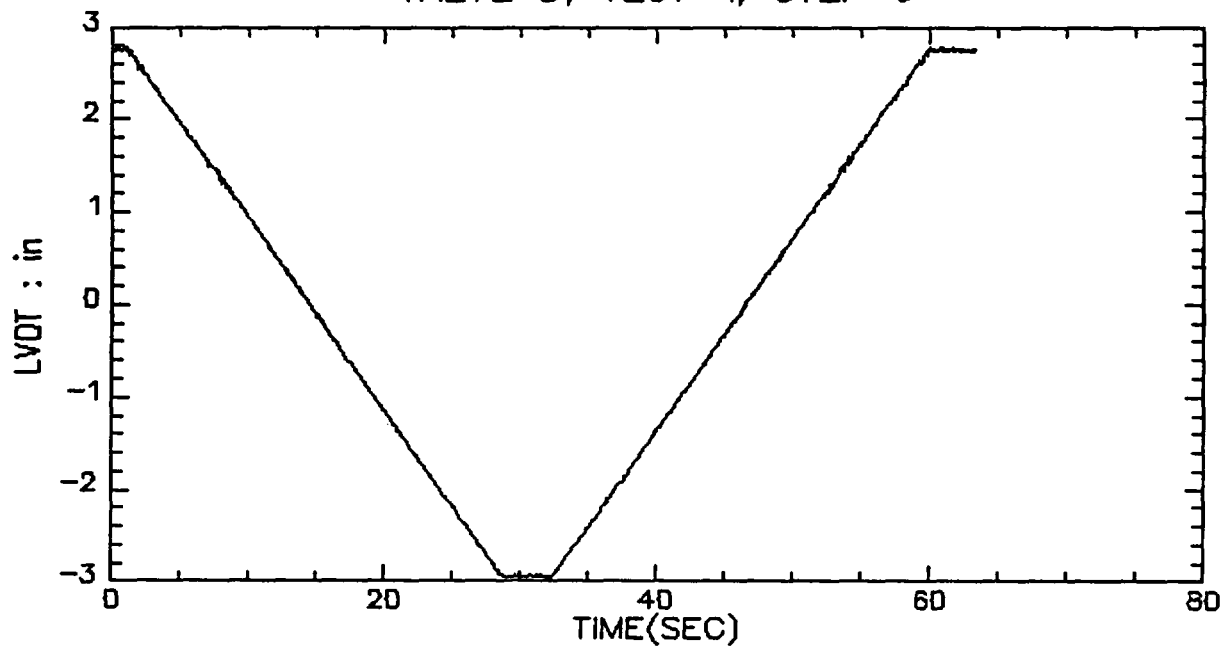

VALVE B, TEST 1, STEP 9

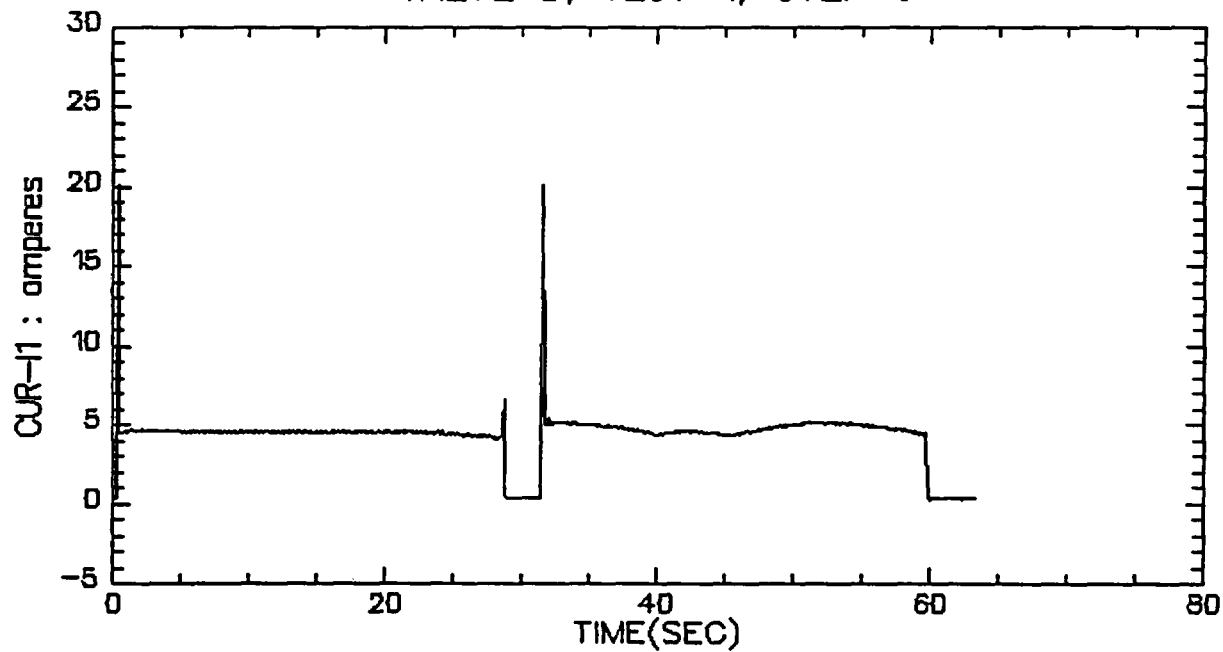

VALVE B, TEST 1, STEP 9

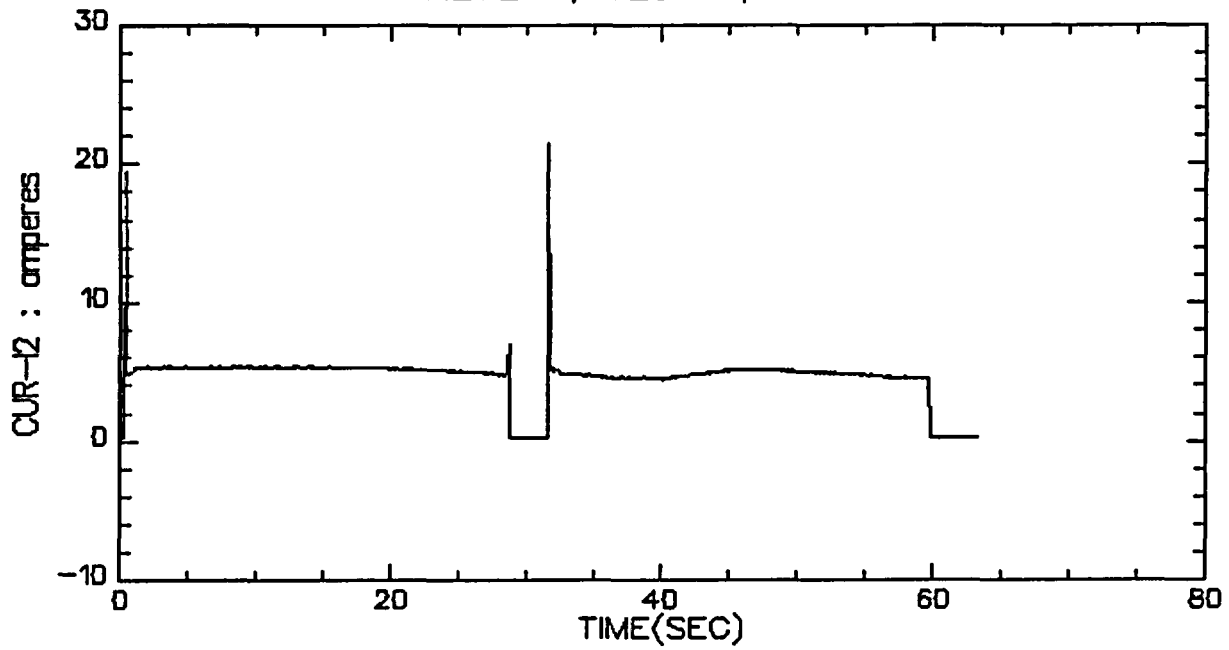

VALVE B, TEST 1, STEP 9

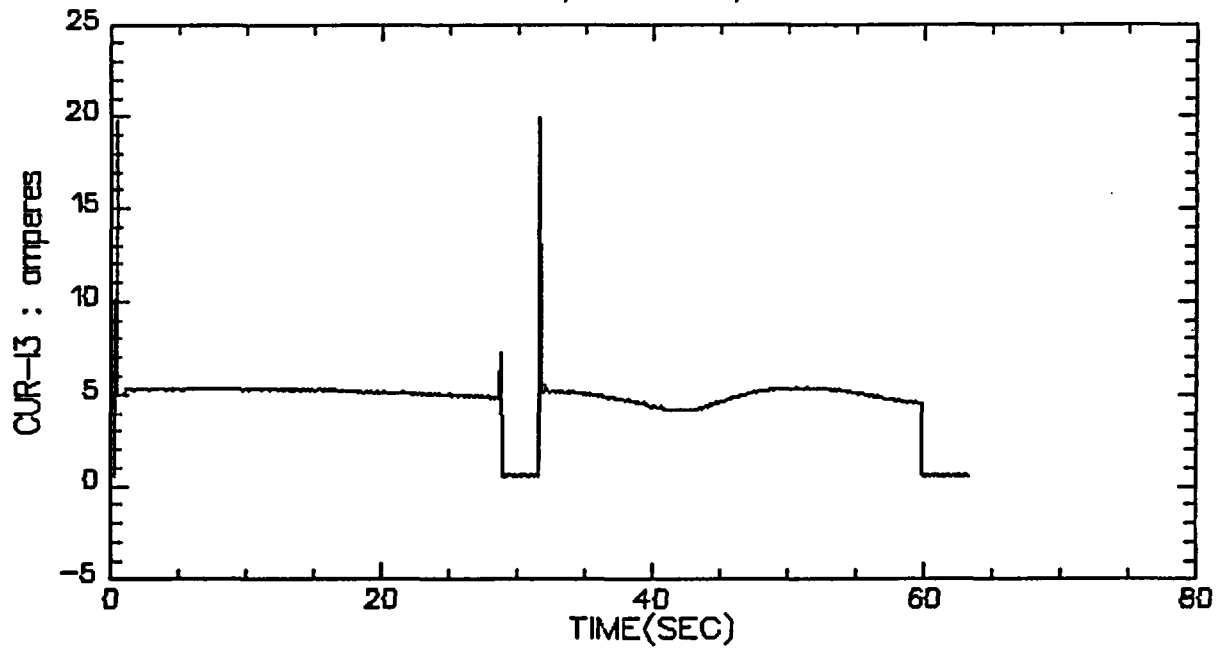

VALVE B, TEST 1, STEP 9

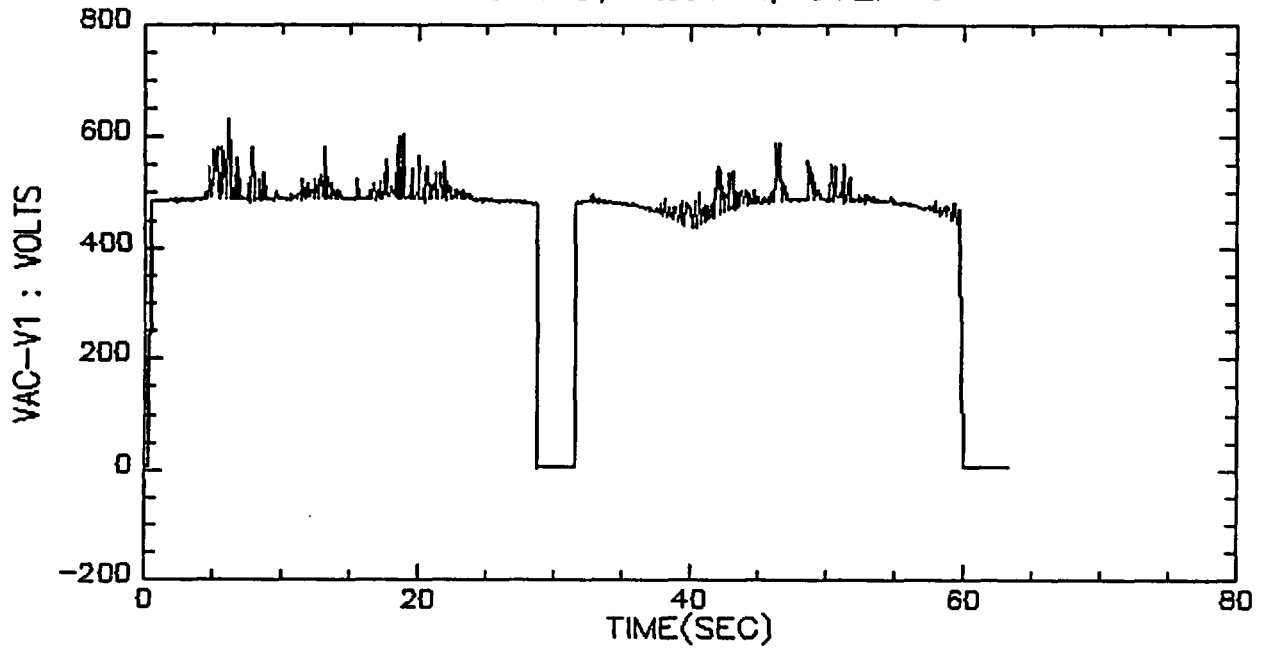

VALVE B, TEST 1, STEP 9

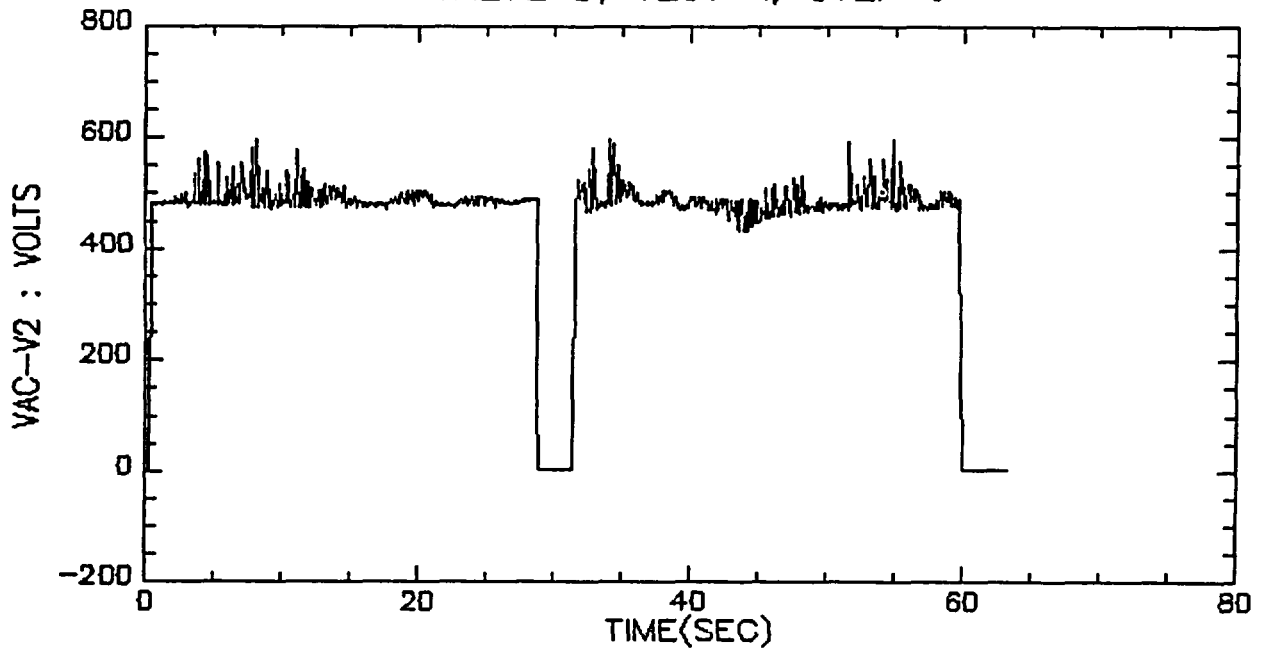

VALVE B, TEST 1, STEP 9

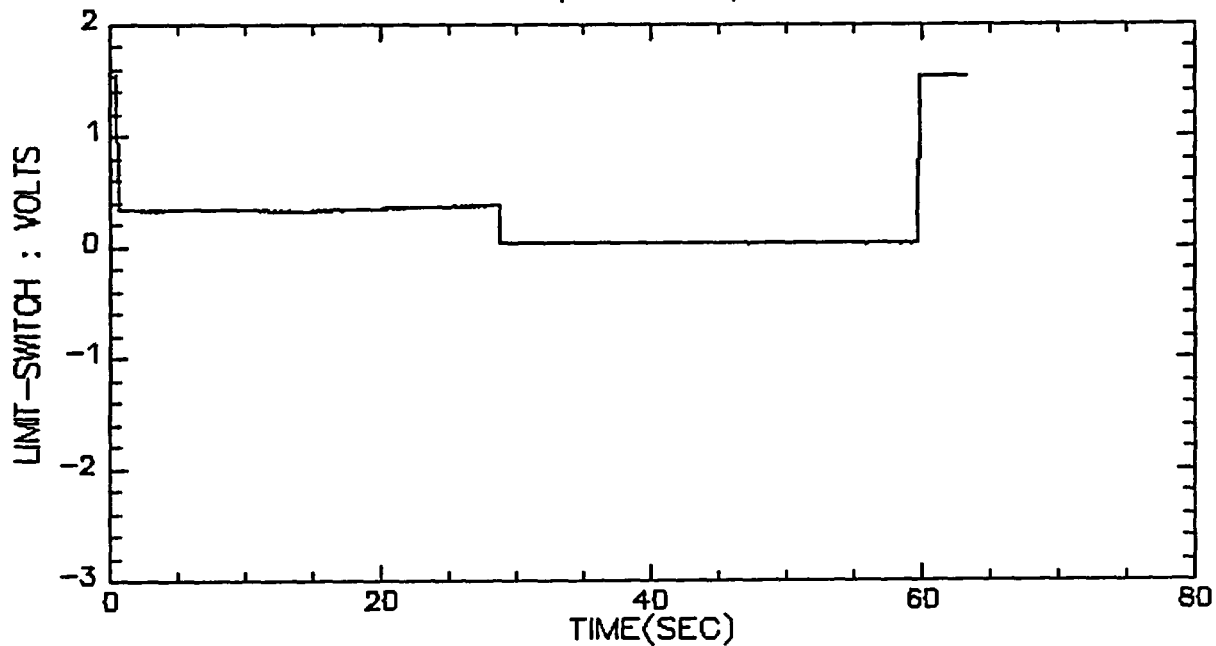

VALVE B, TEST 1, STEP 9

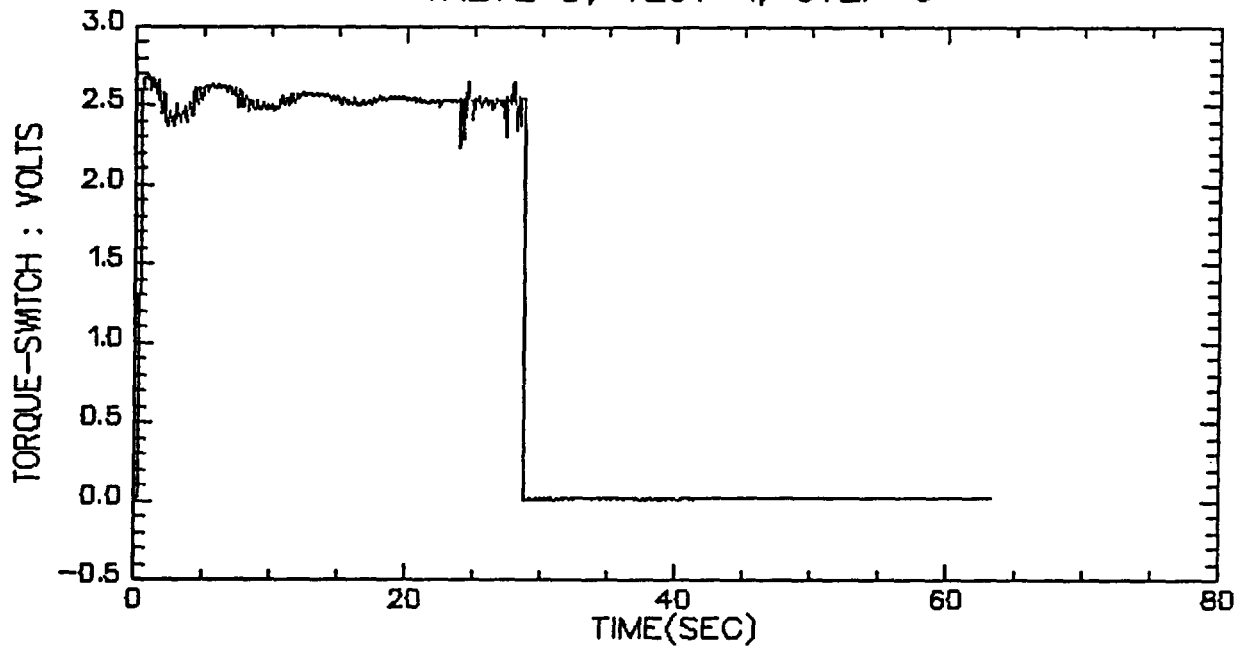

VALVE B, TEST 1, STEP 9

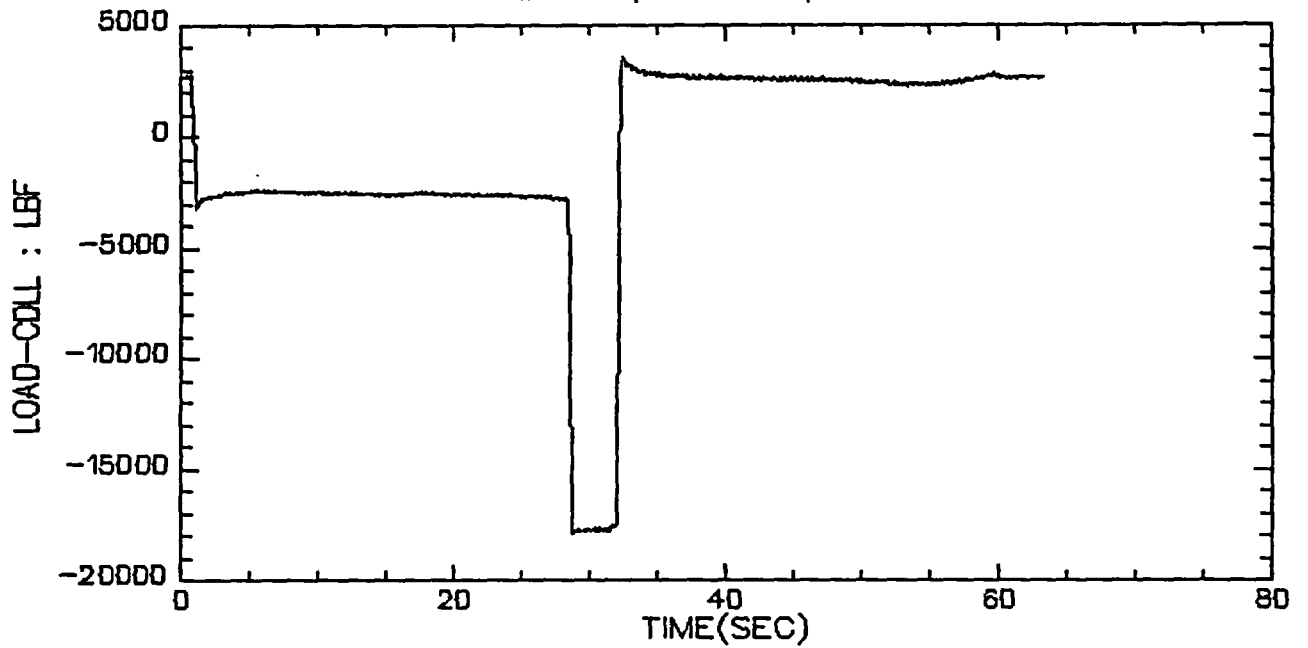

VALVE B, TEST 1, STEP 12

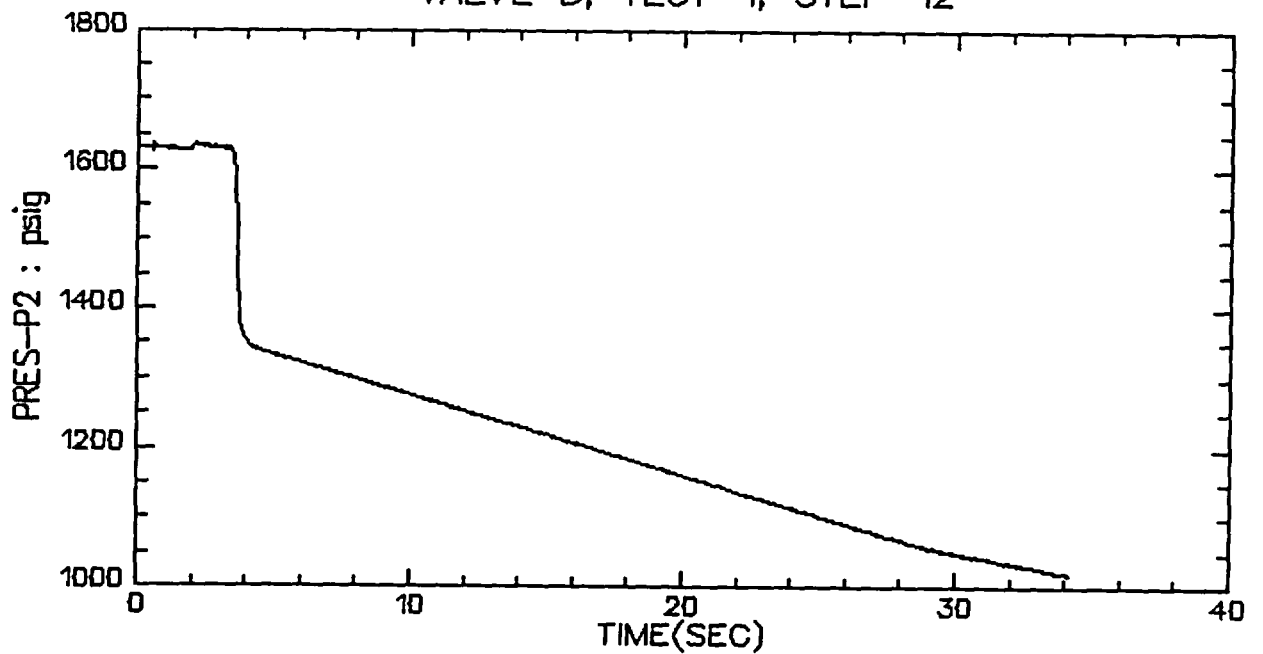

VALVE B, TEST 1, STEP 12

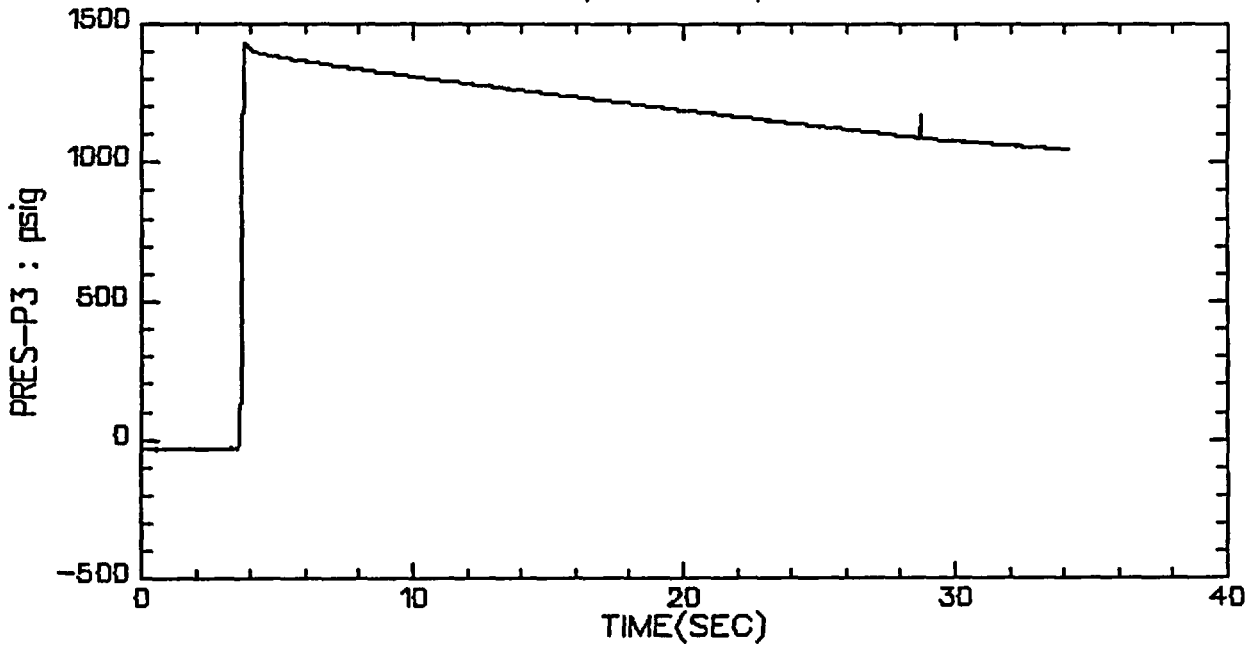

VALVE B, TEST 1, STEP 12

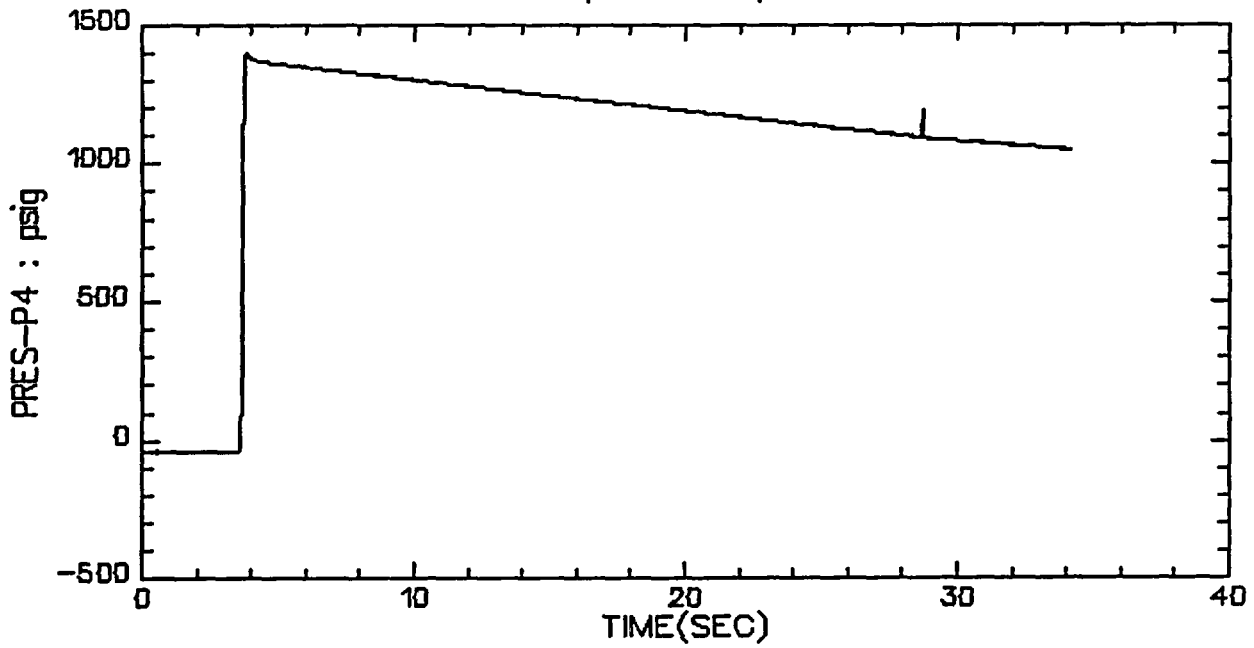

VALVE B, TEST 1, STEP 12

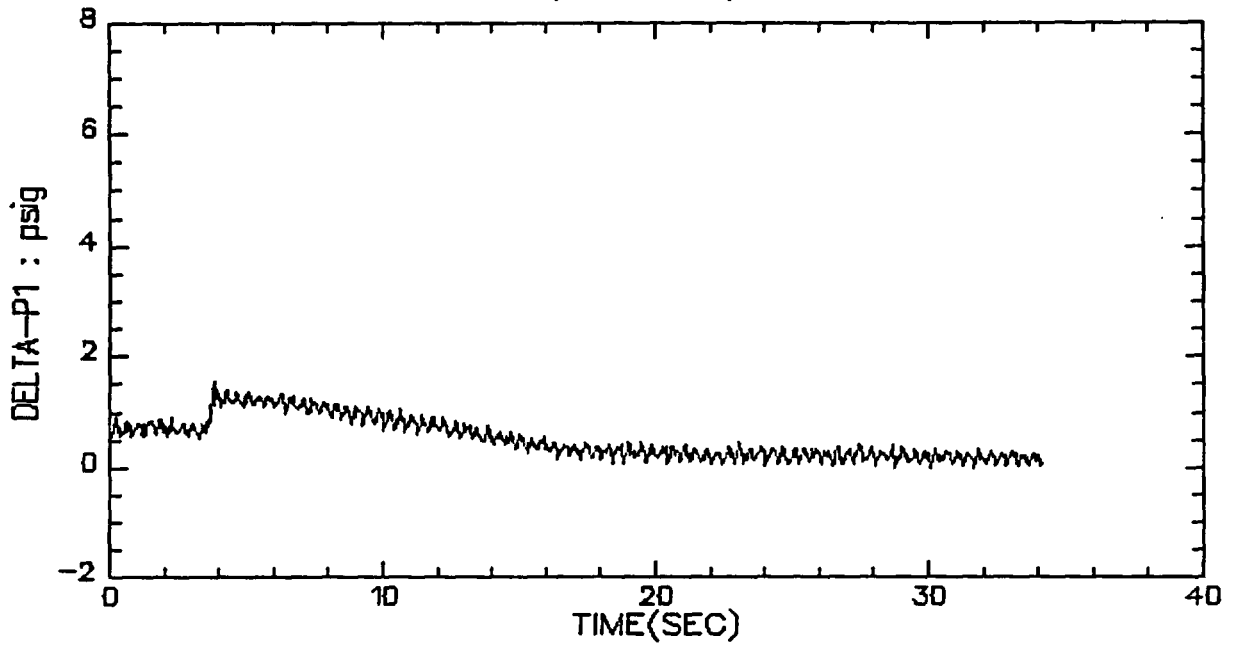

VALVE B, TEST 1, STEP 12

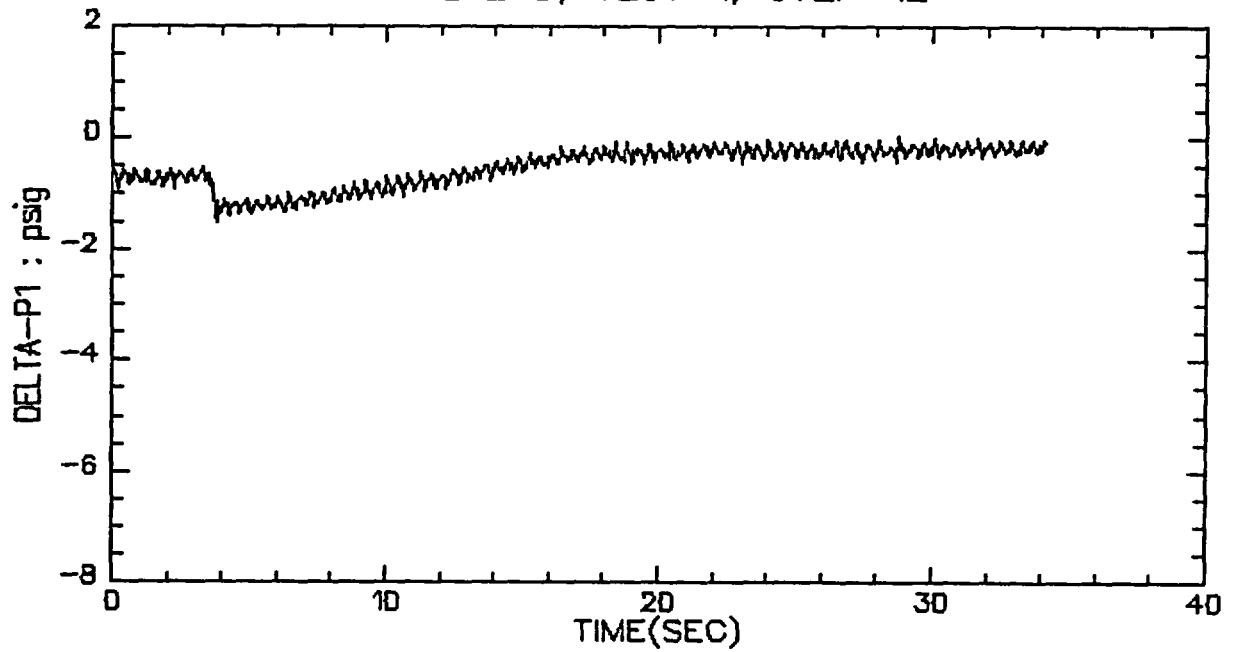

VALVE B, TEST 1, STEP 12

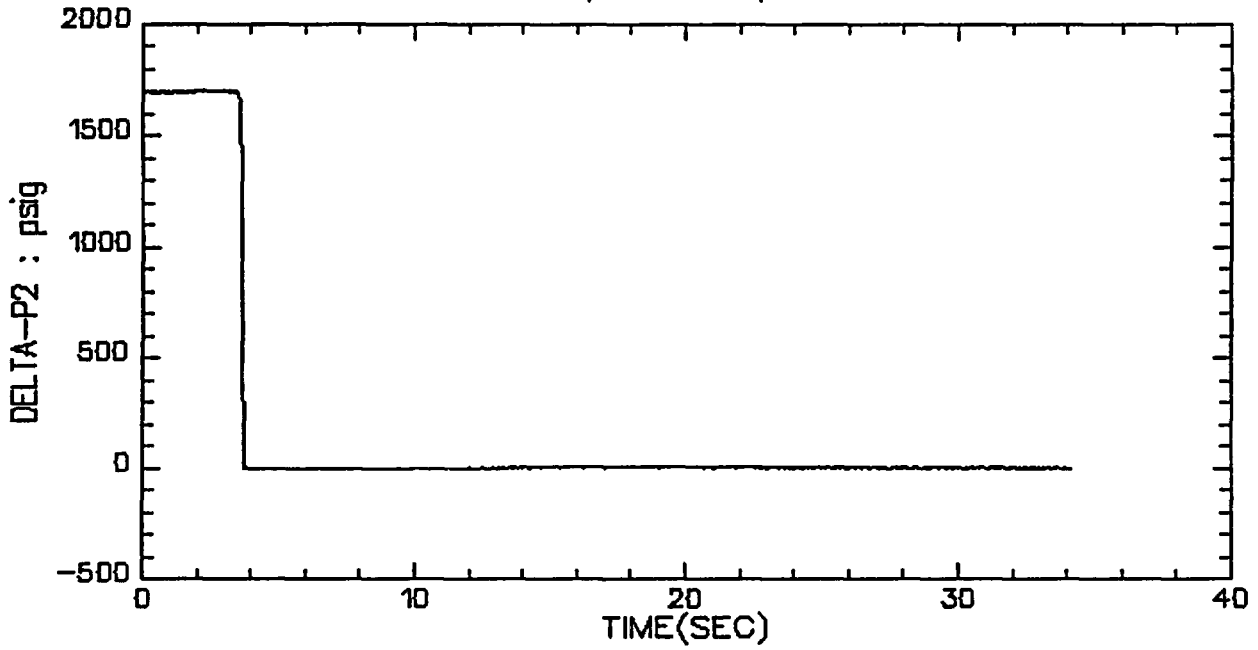

VALVE B, TEST 1, STEP 12

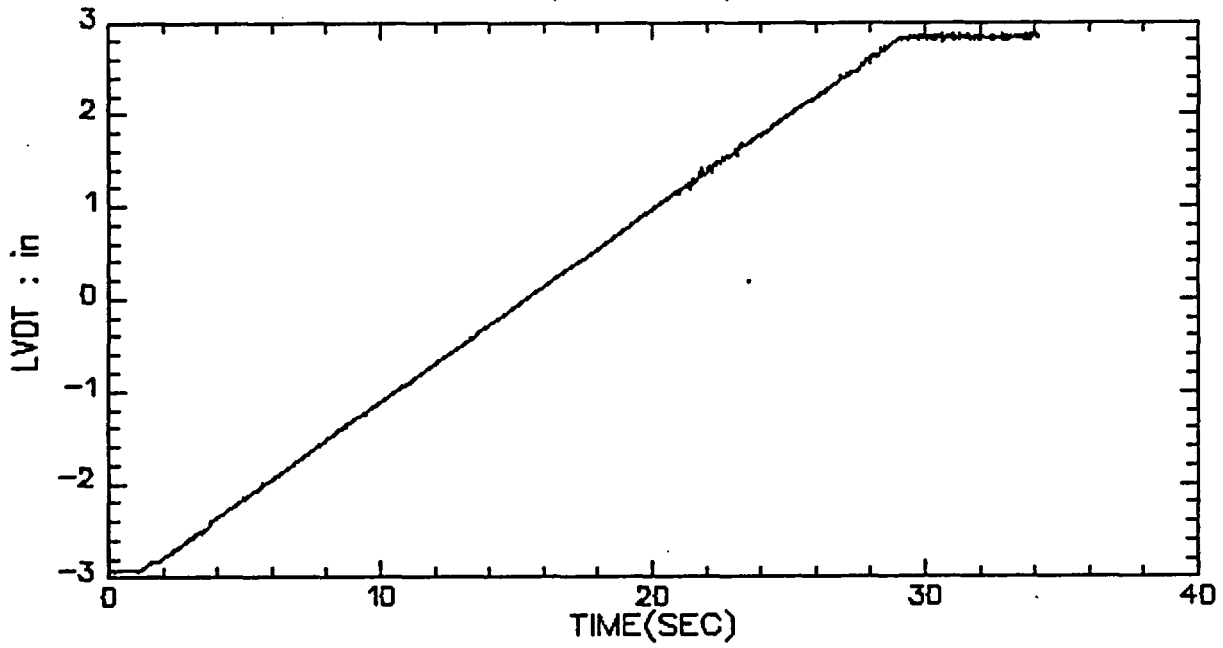

VALVE B, TEST 1, STEP 12

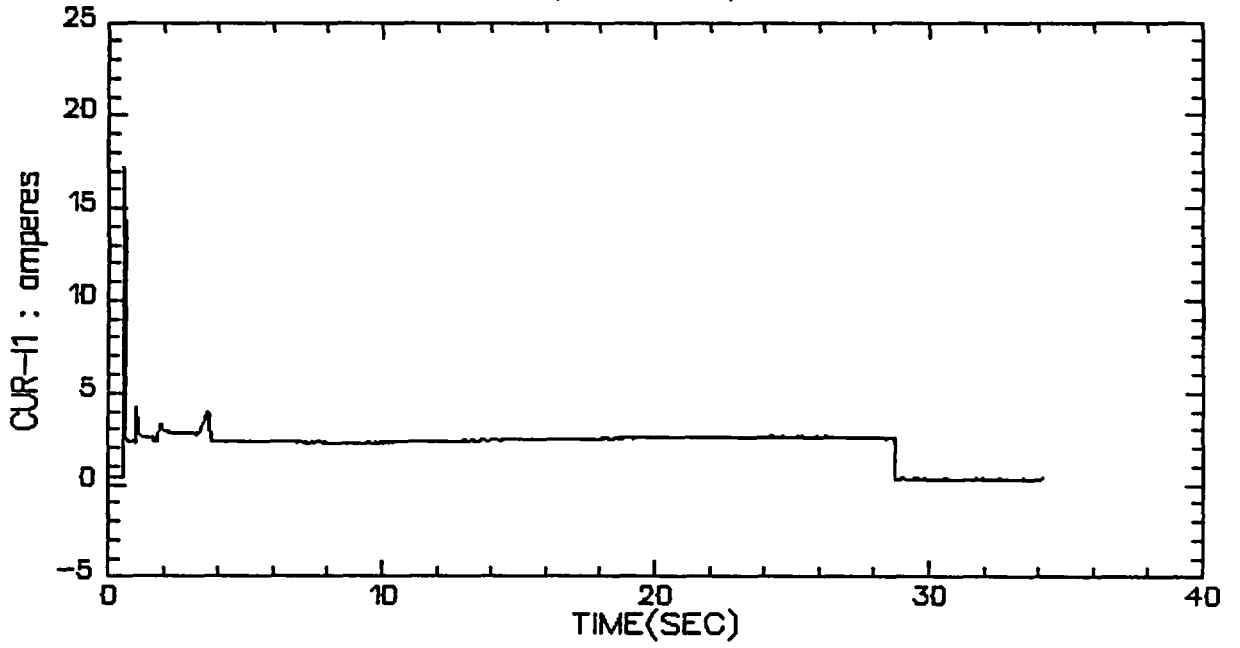

VALVE B, TEST 1, STEP 12

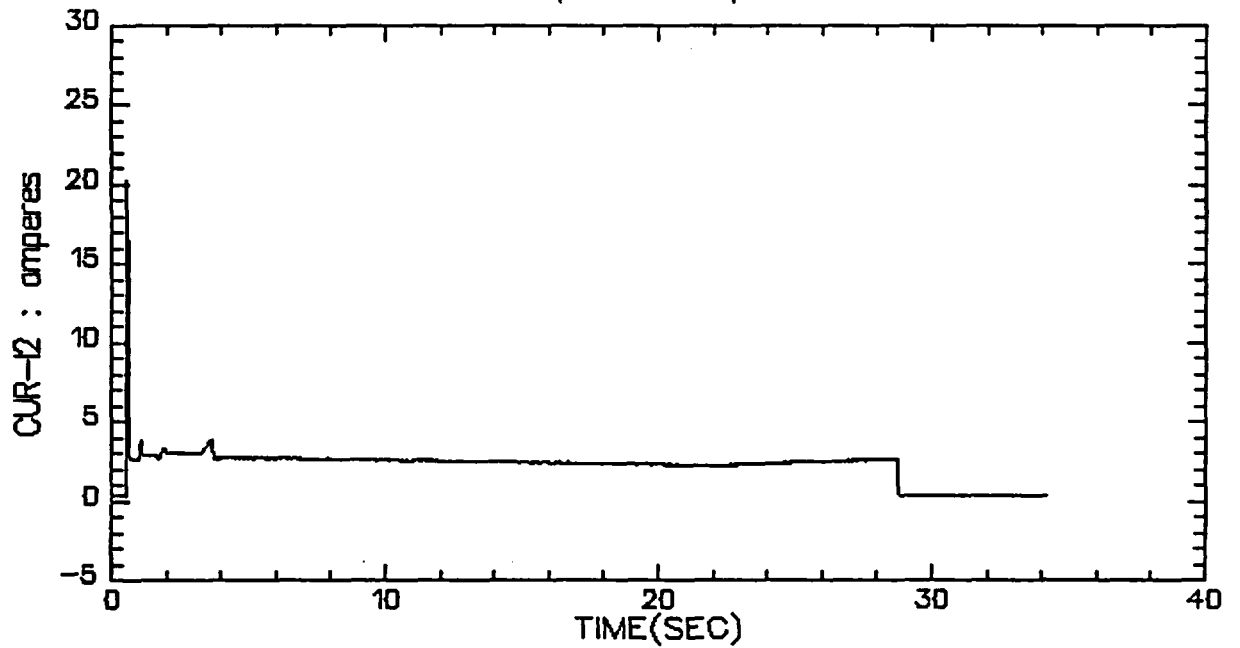

VALVE B, TEST 1, STEP 12

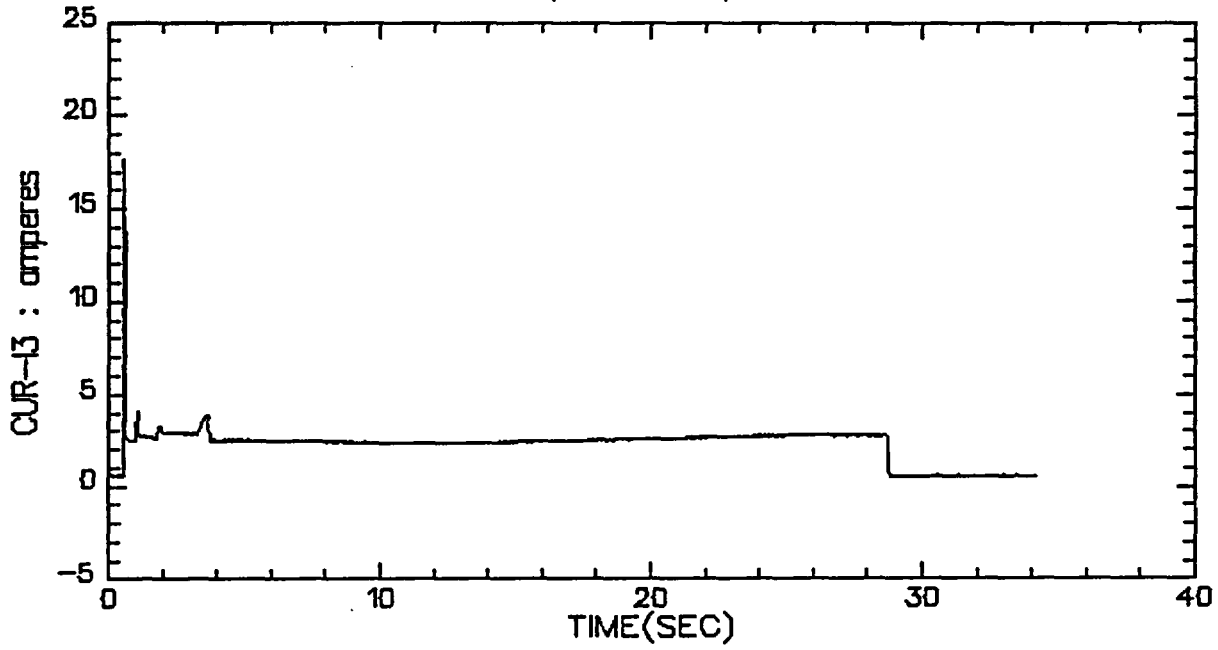

VALVE B, TEST 1, STEP 12

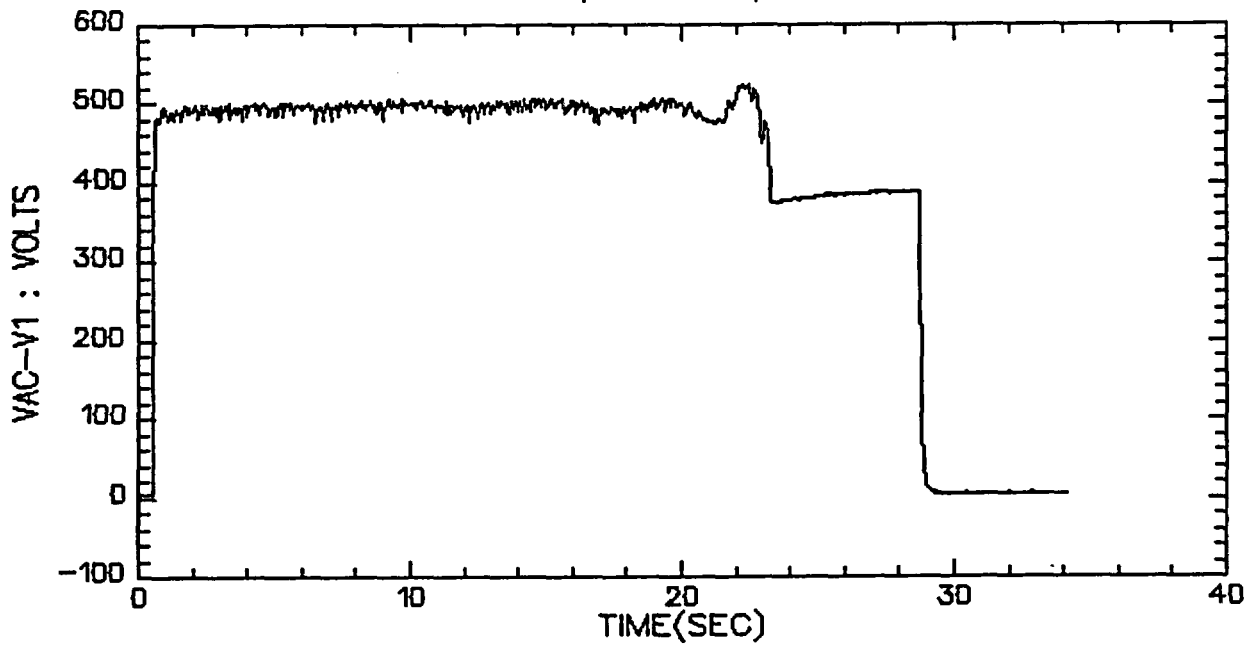

VALVE B, TEST 1, STEP 12

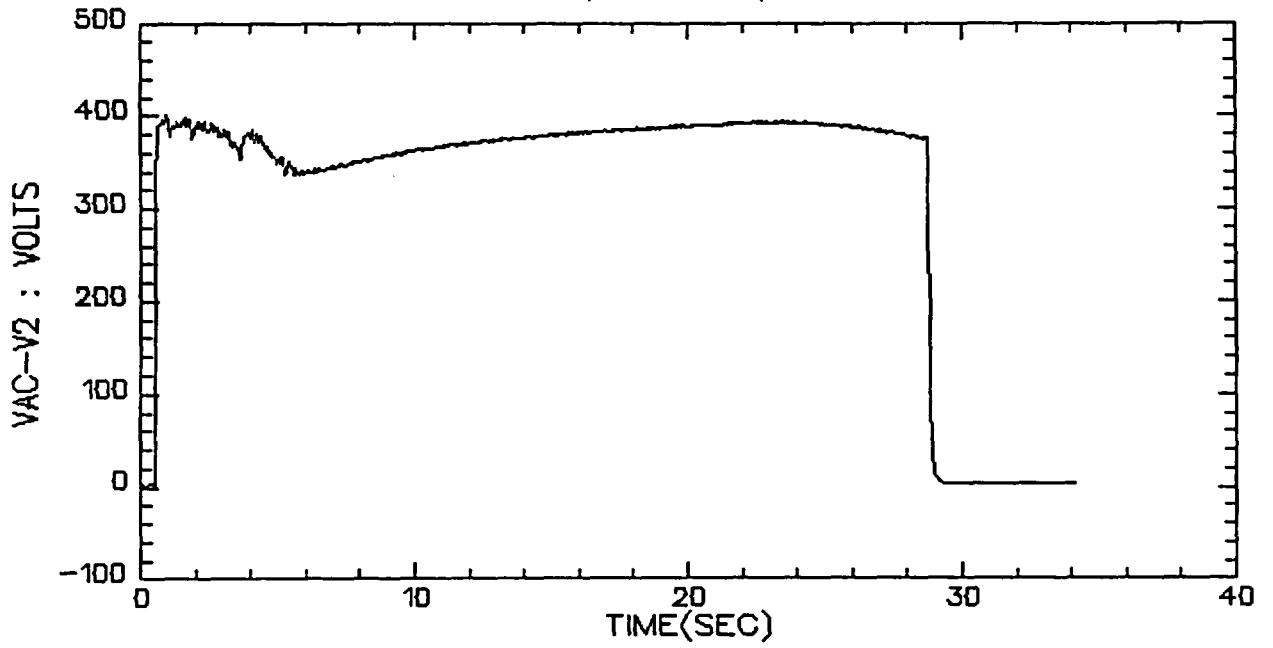

VALVE B, TEST 1, STEP 12

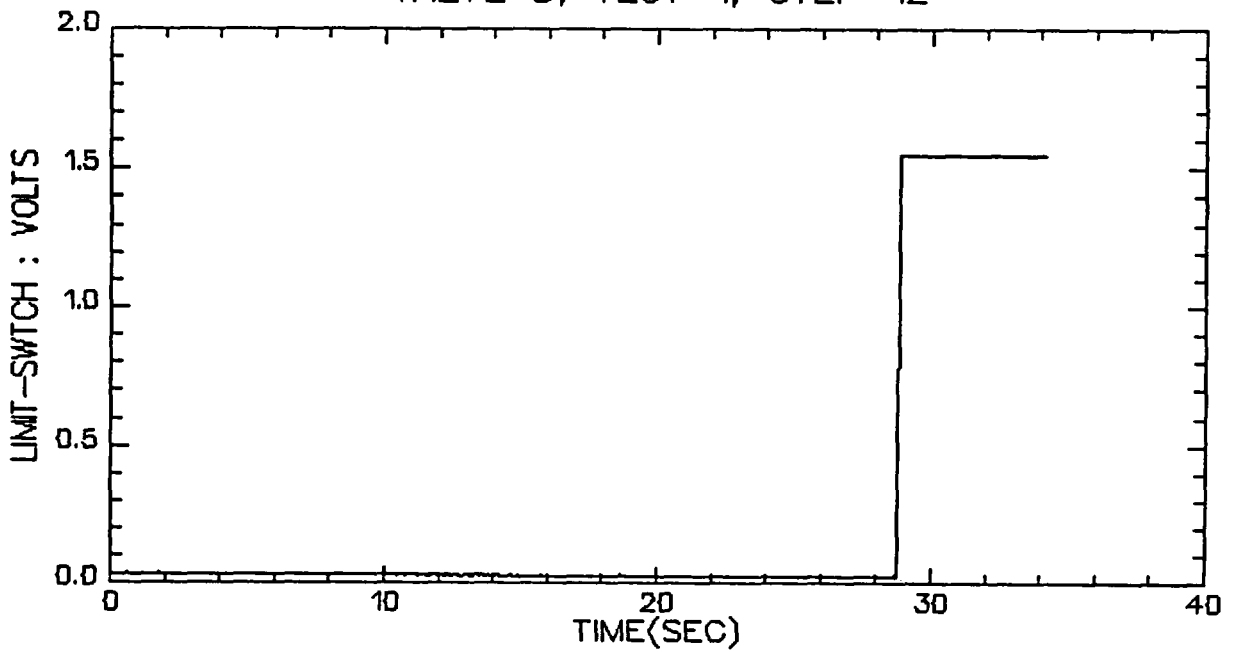

VALVE B, TEST 1, STEP 12

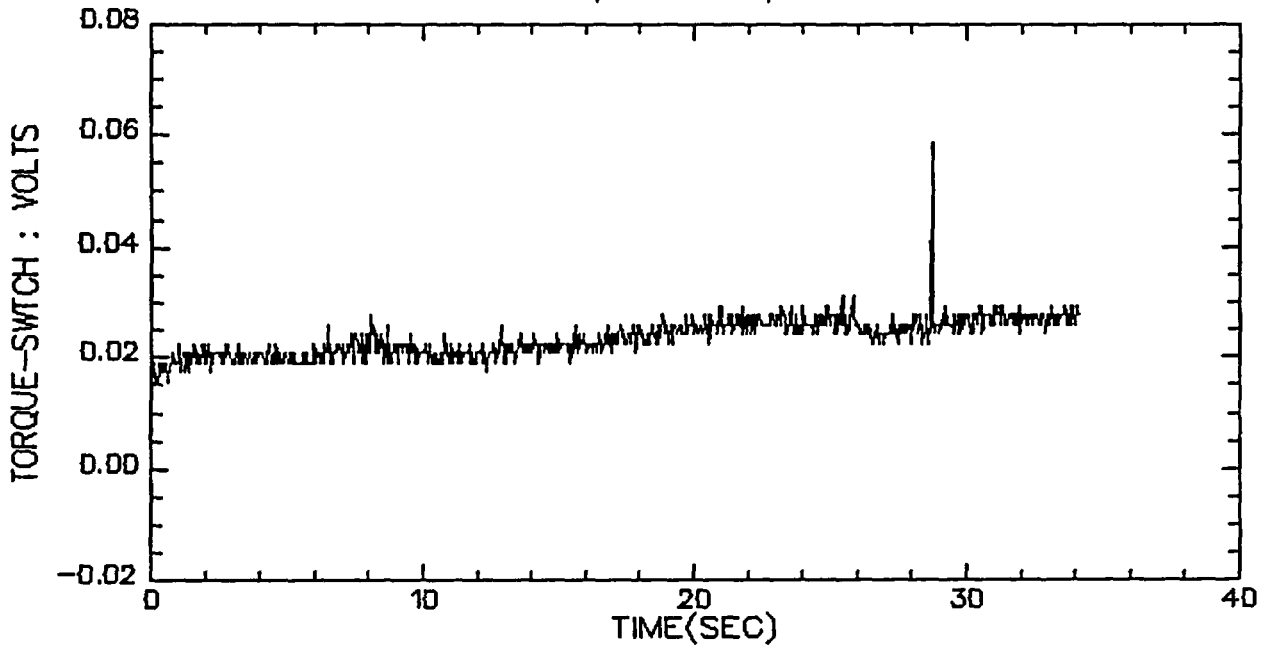

VALVE B, TEST 1, STEP 12

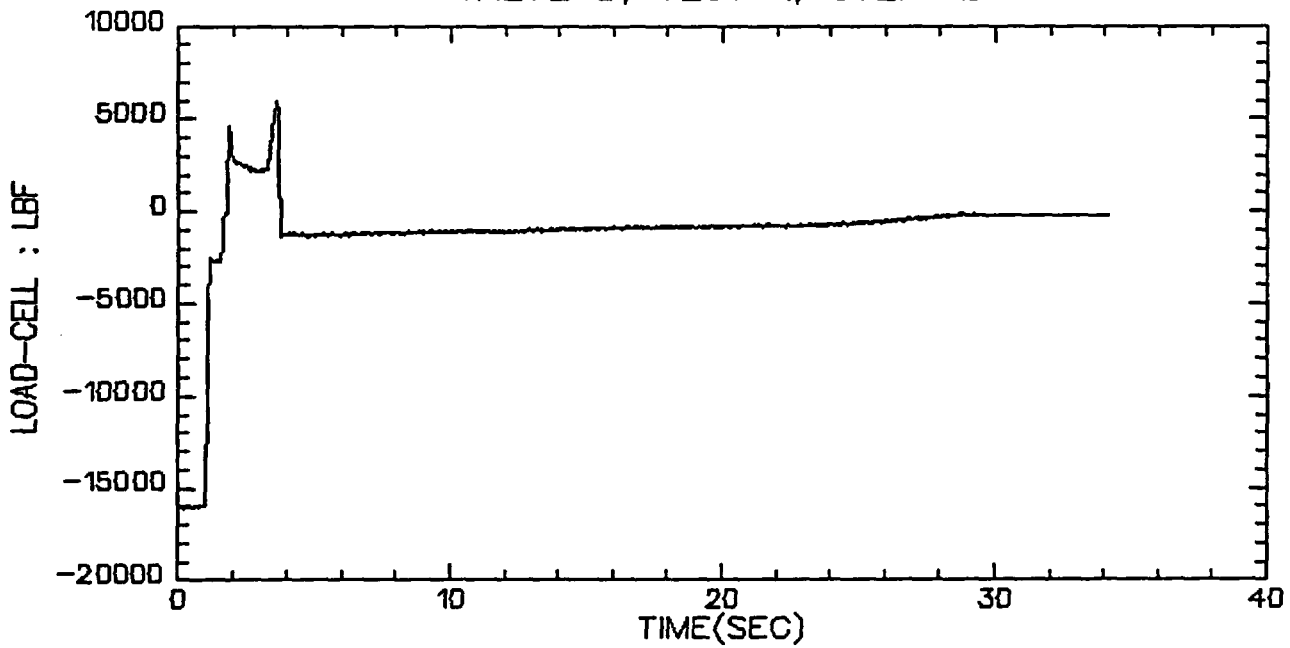

VALVE B, TEST 1, STEP 19

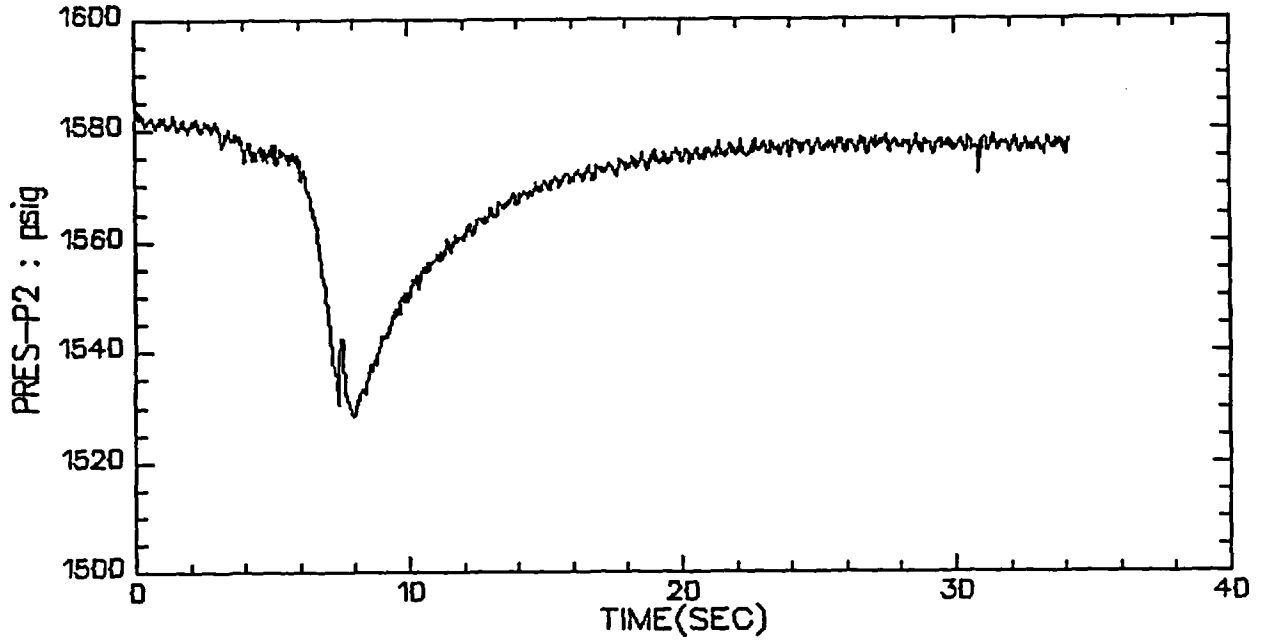

VALVE B, TEST 1, STEP 19

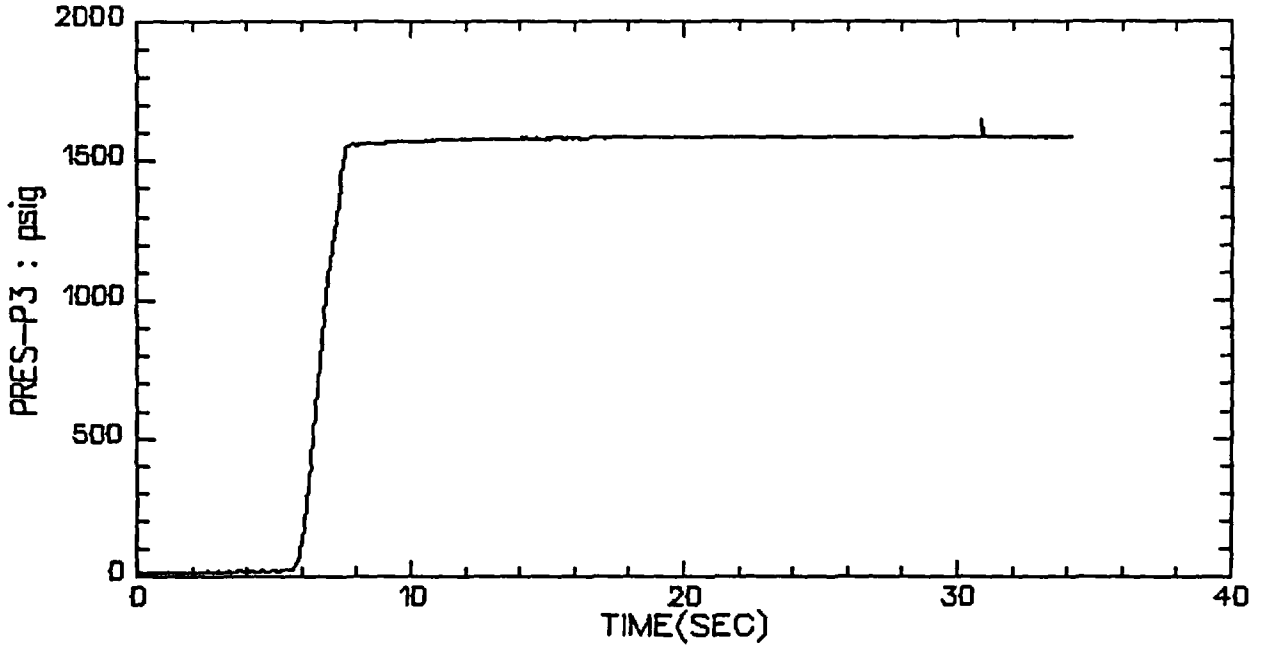

VALVE B, TEST 1, STEP 19

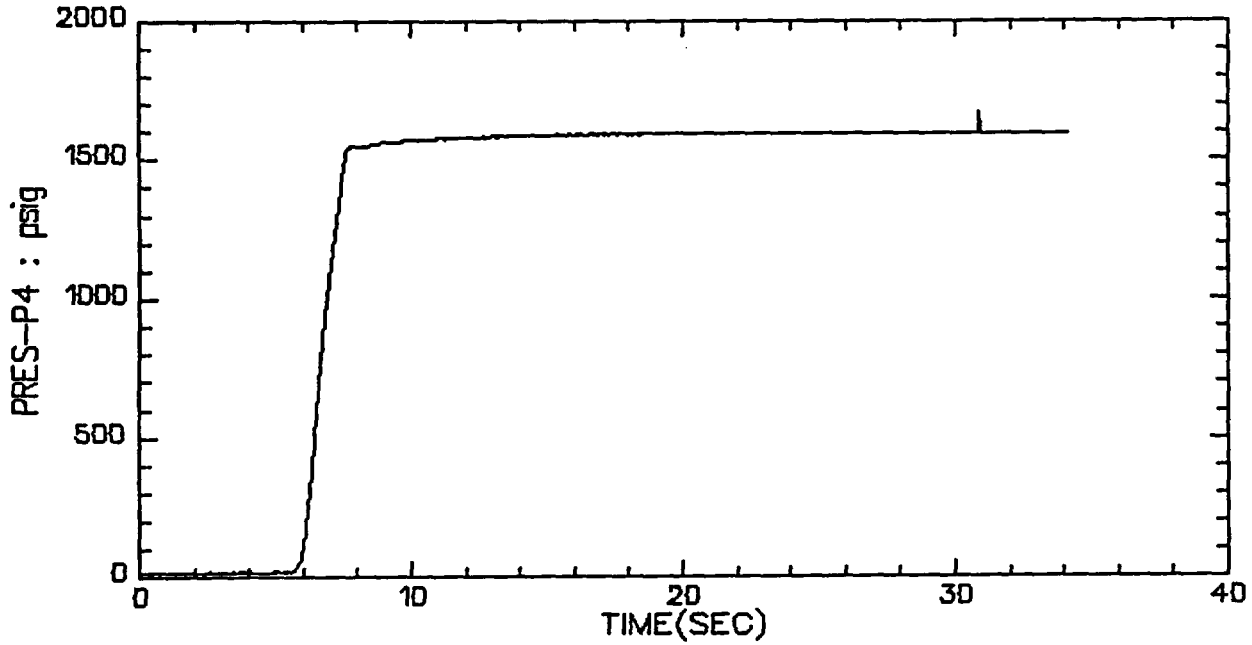

VALVE B, TEST 1, STEP 19

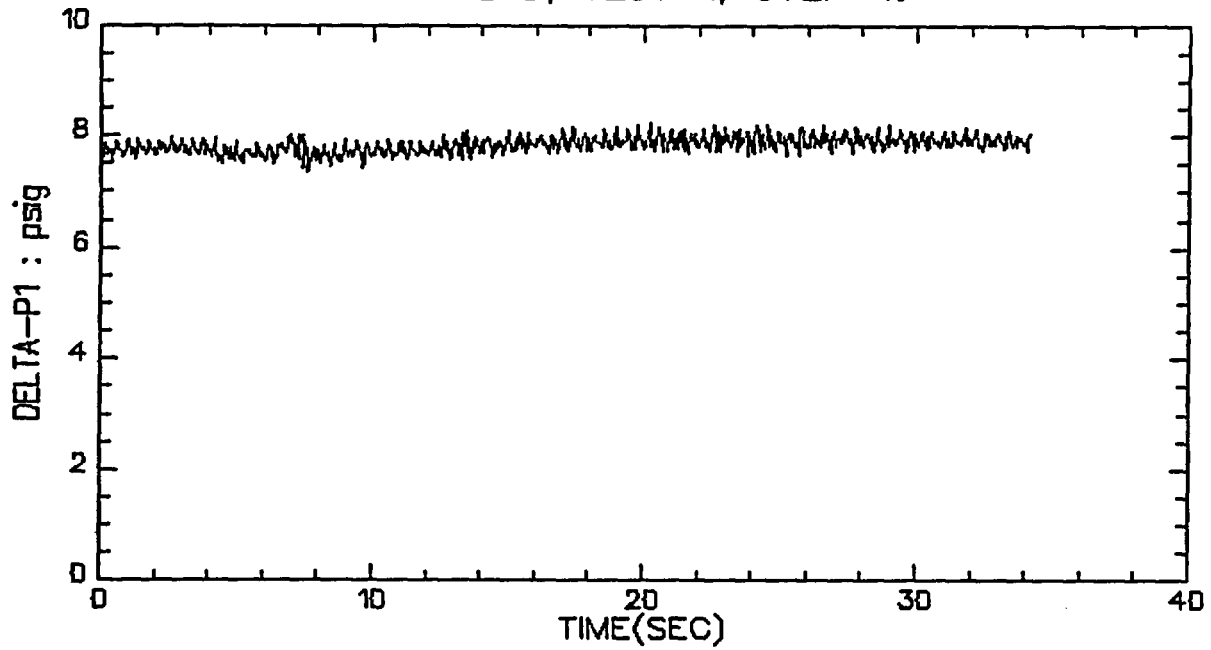

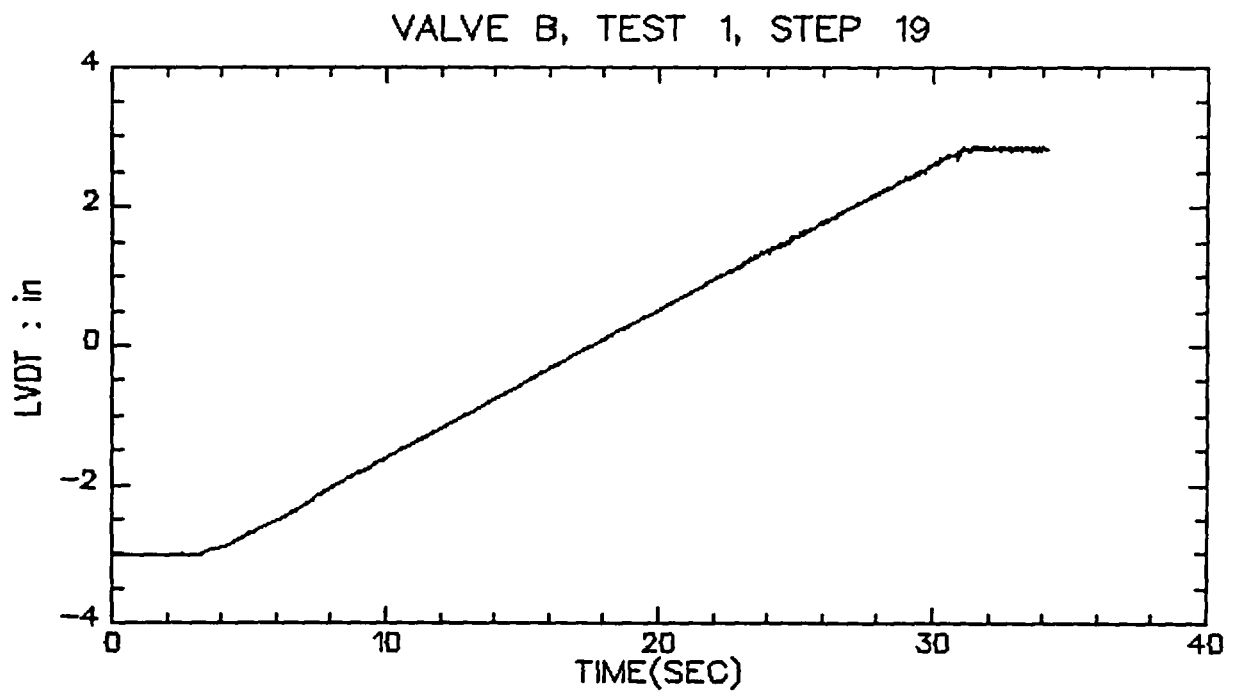
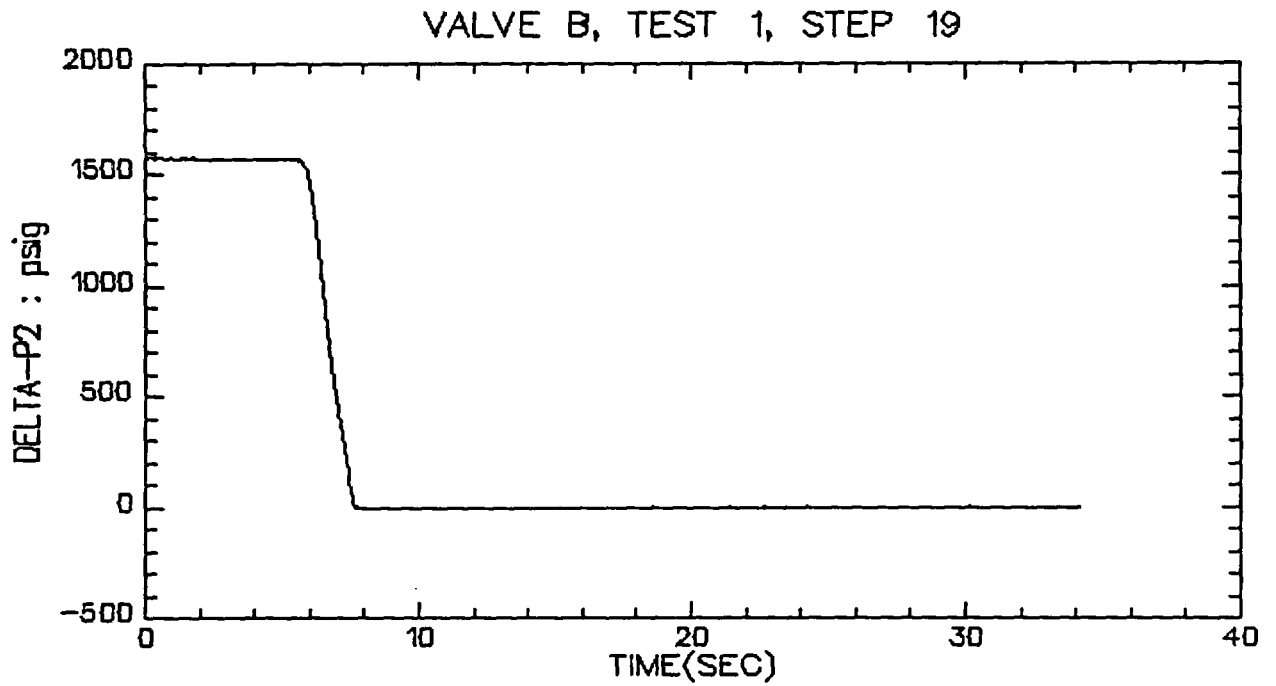

VALVE B, TEST 1, STEP 19

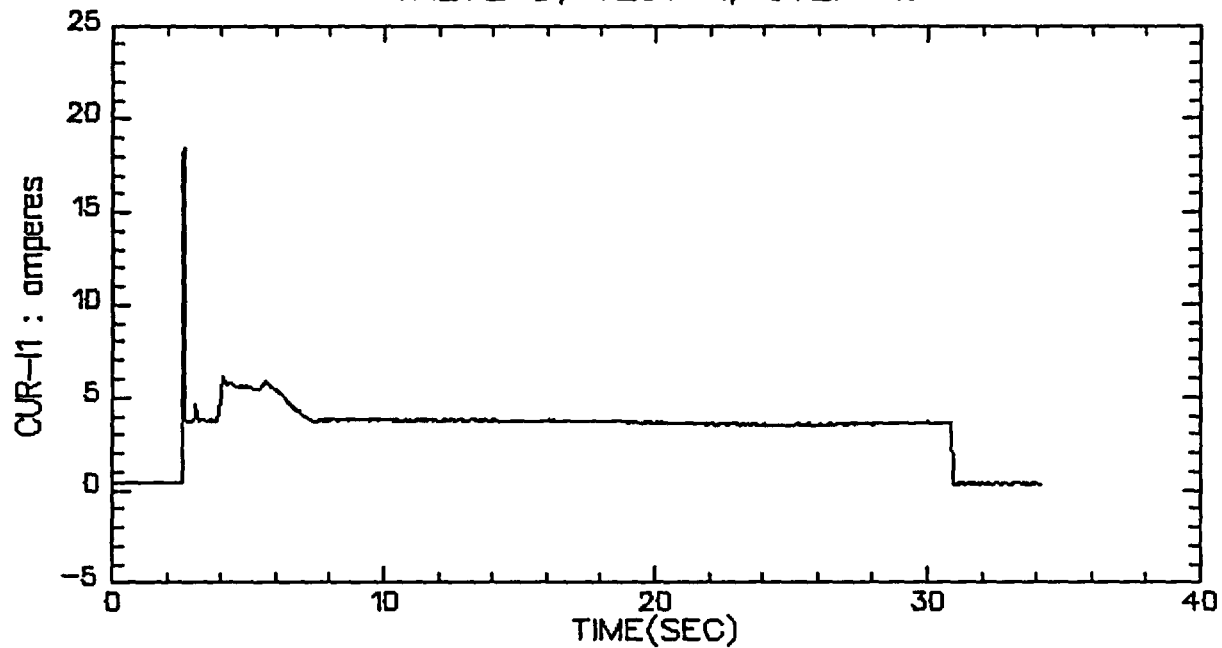

VALVE B, TEST 1, STEP 19

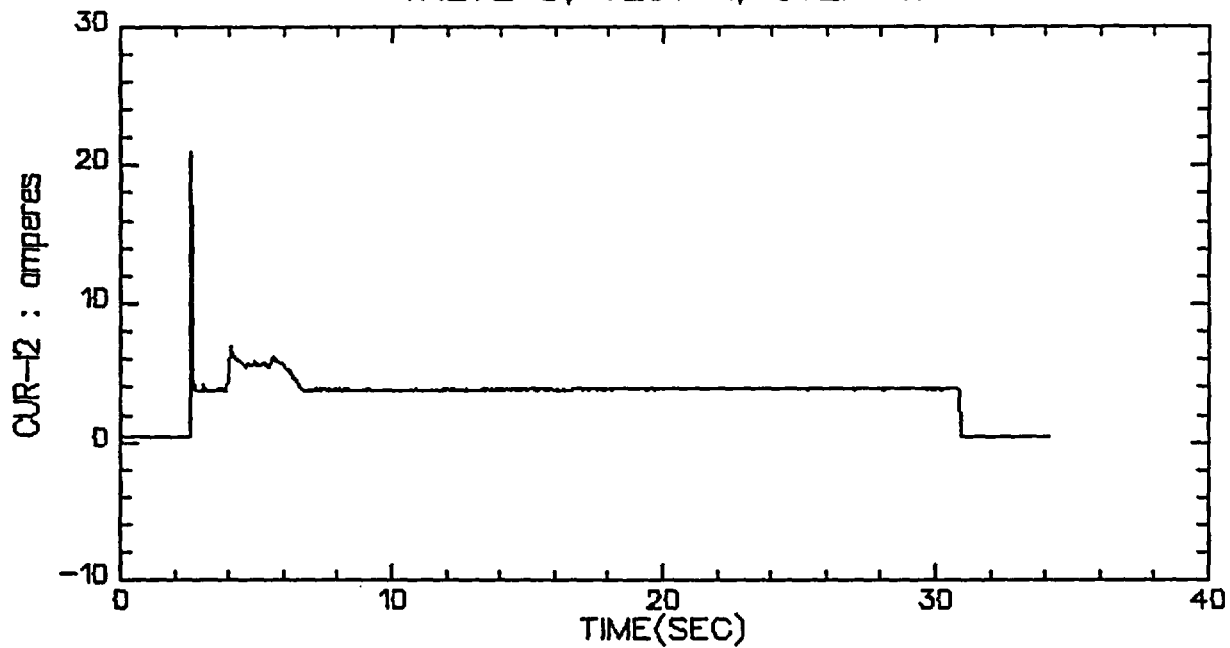

VALVE B, TEST 1, STEP 19

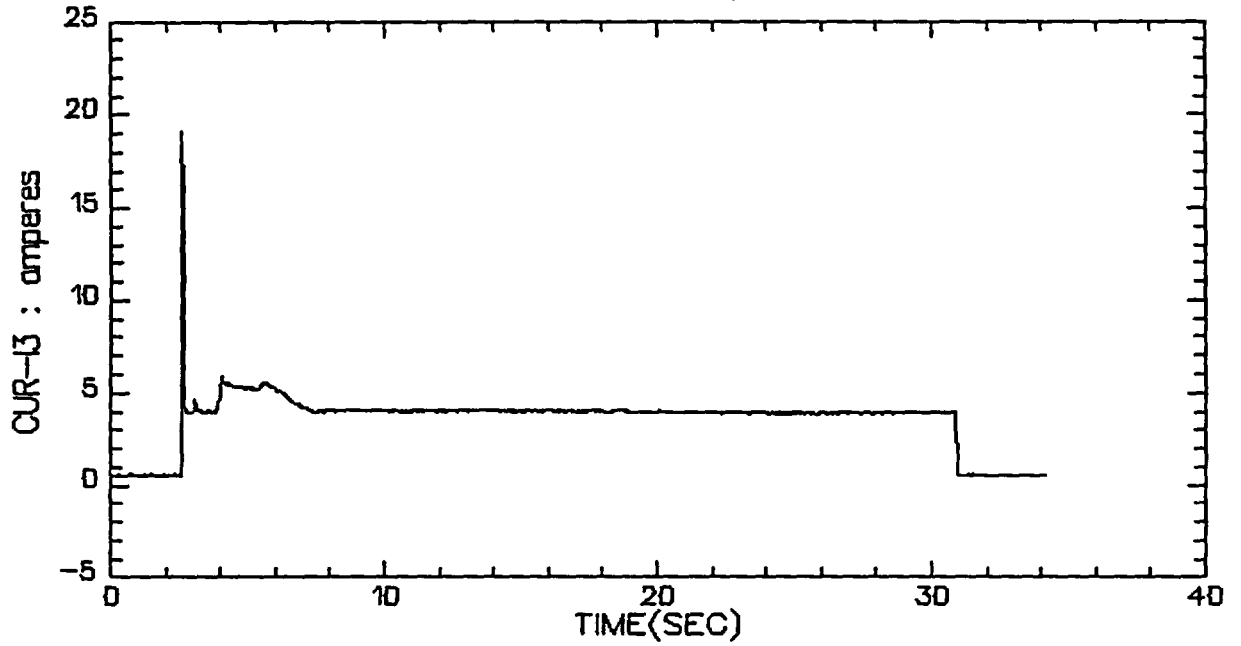

VALVE B, TEST 1, STEP 19

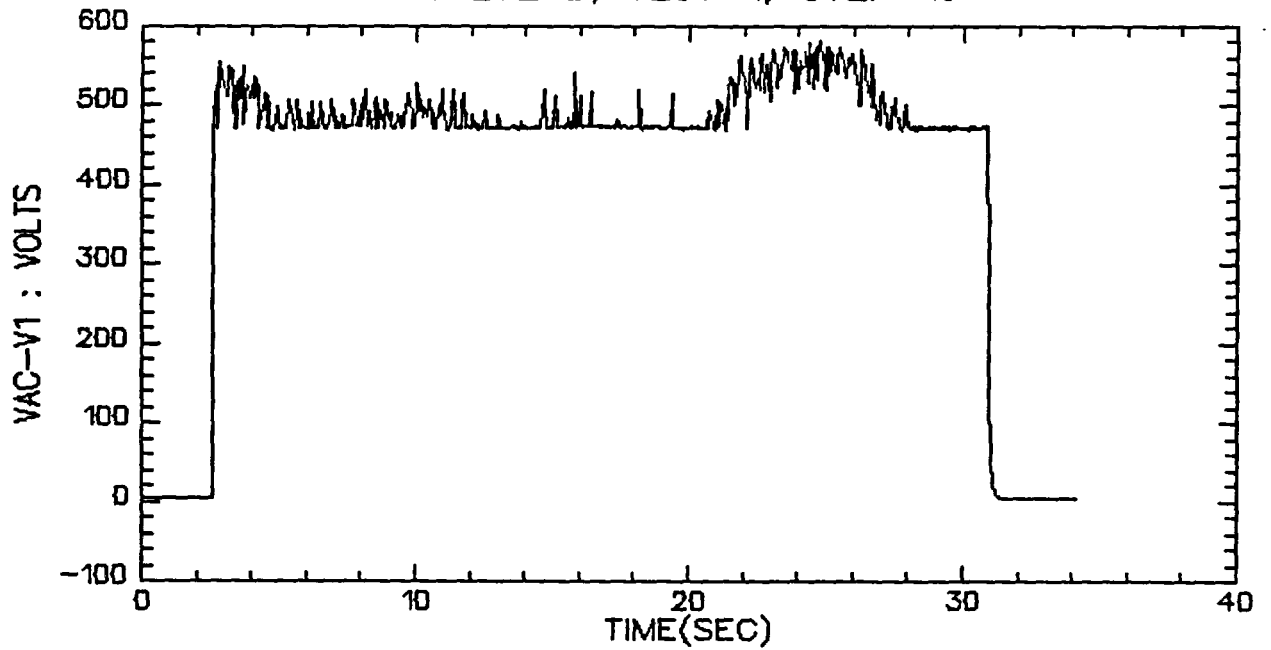

VALVE B, TEST 1, STEP 19

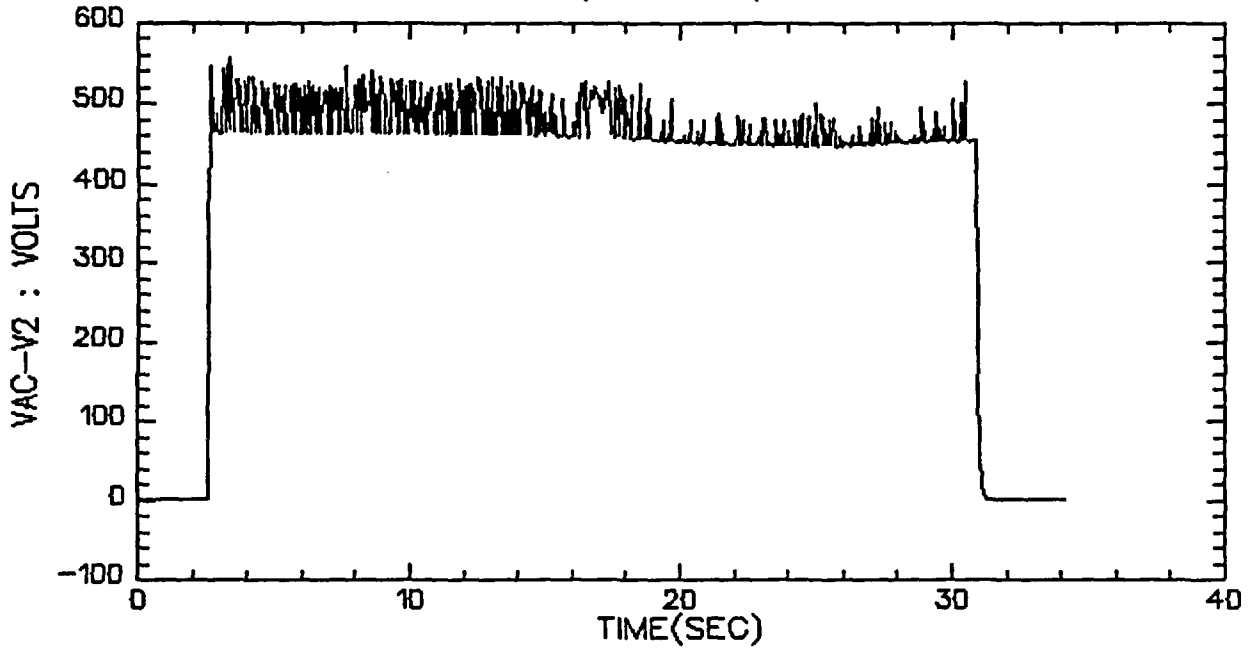

VALVE B, TEST 1, STEP 19

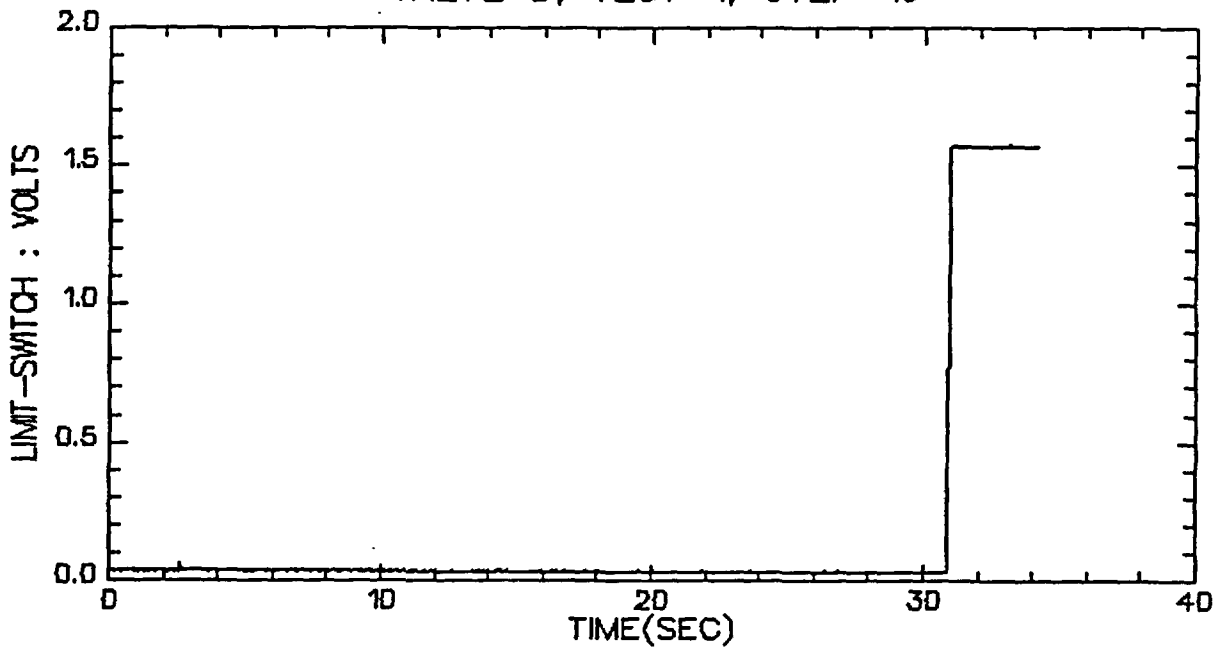

VALVE B, TEST 1, STEP 19

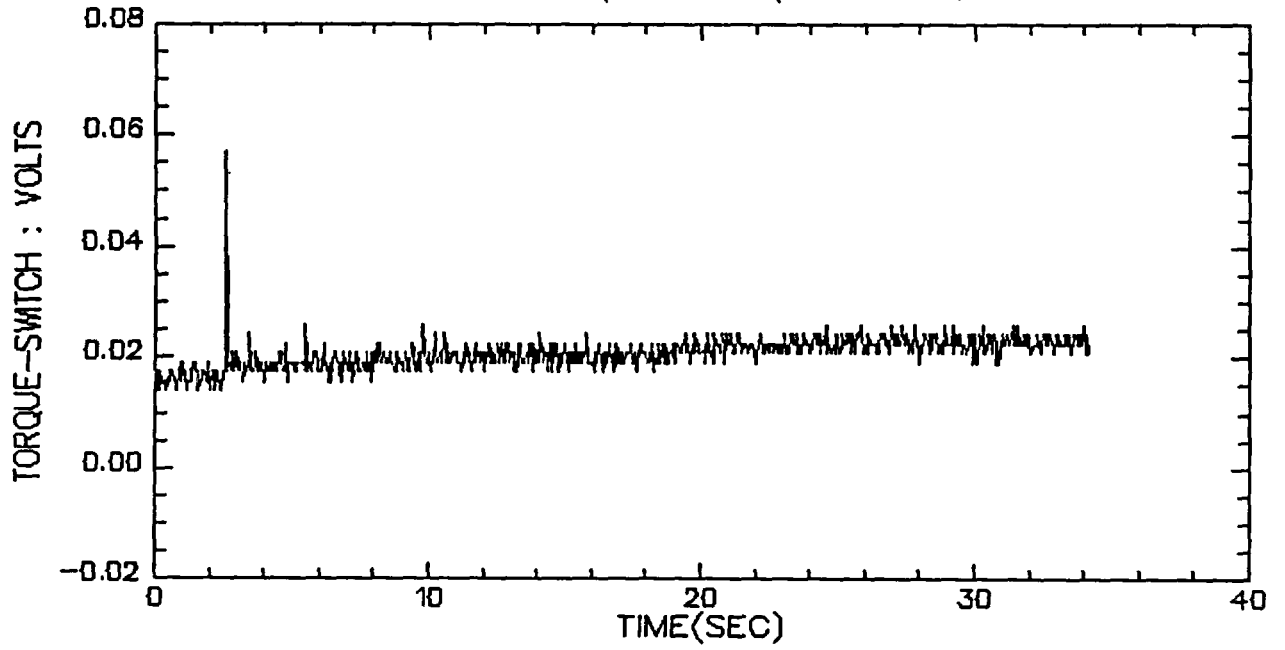

VALVE B, TEST 1, STEP 19

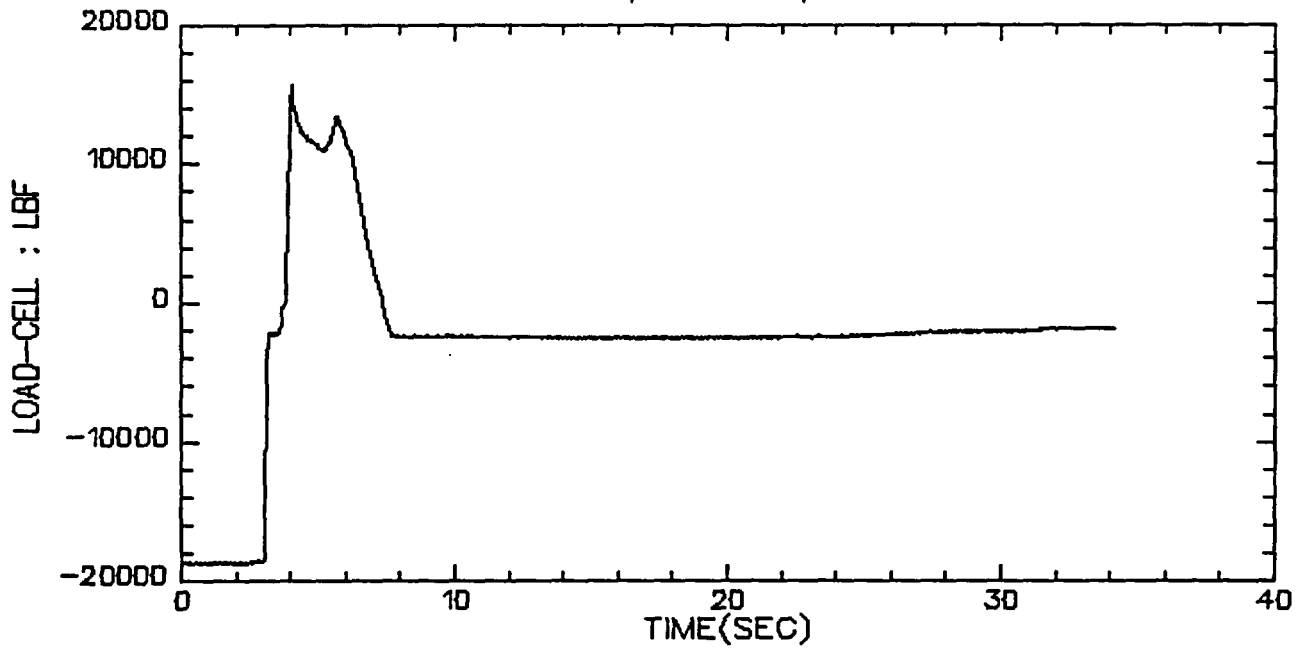

VALVE B, TEST 2, STEP 1

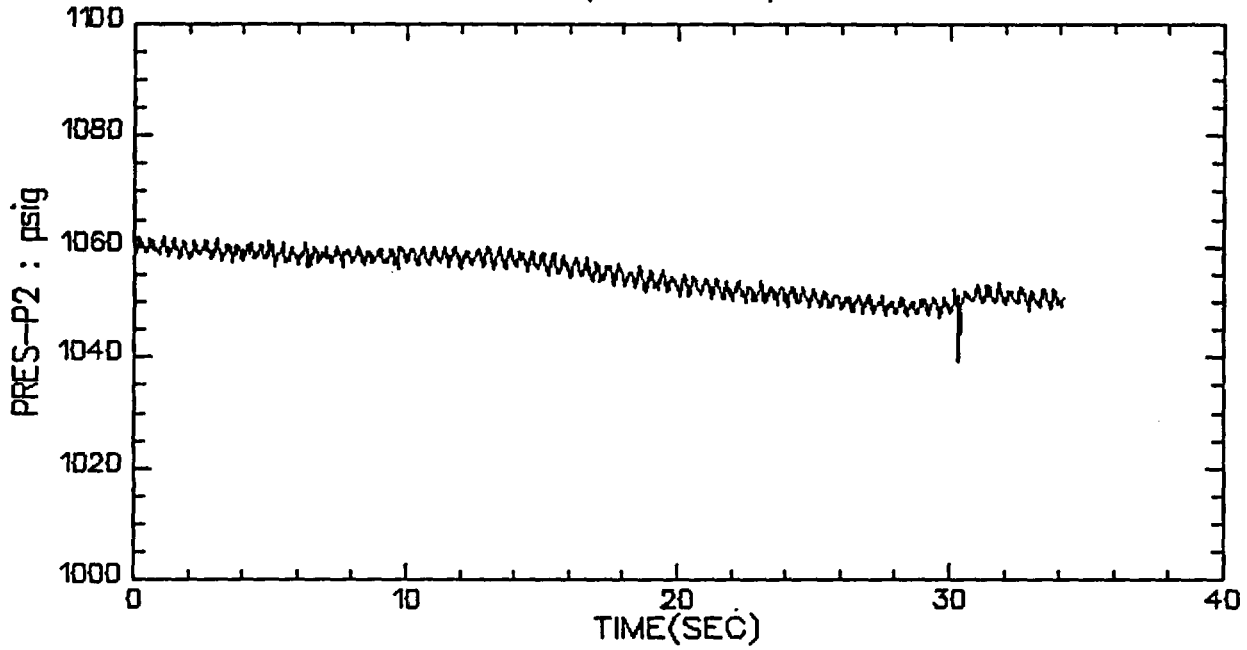

VALVE B, TEST 2, STEP 1

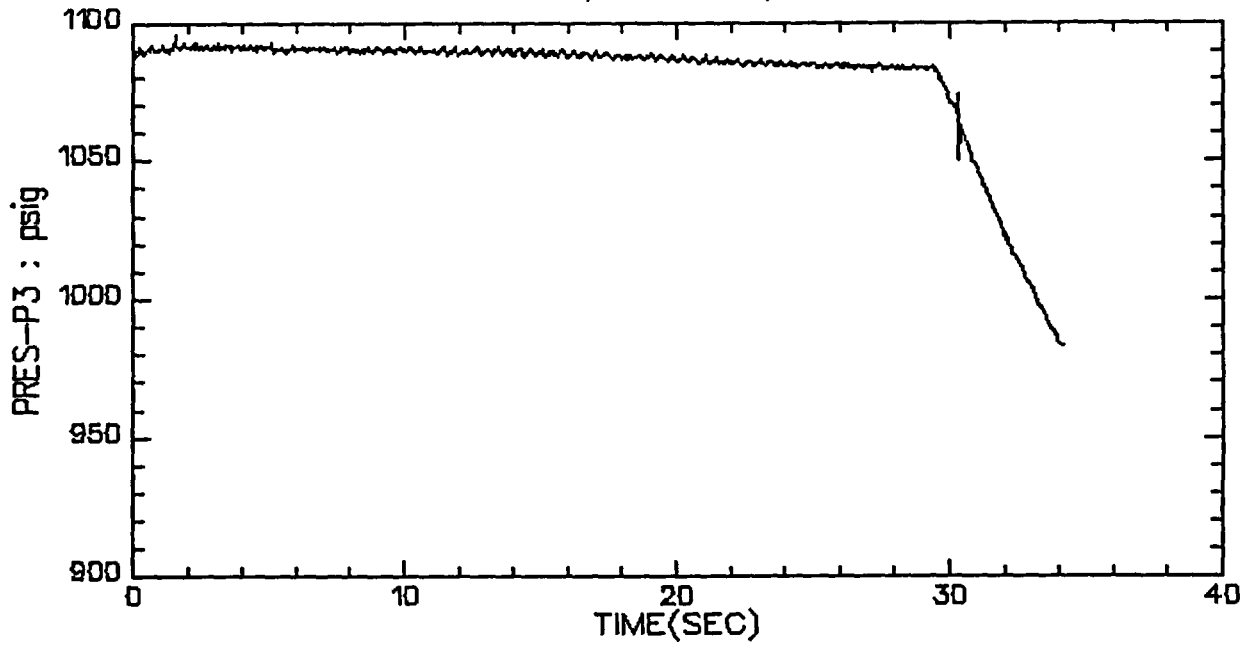

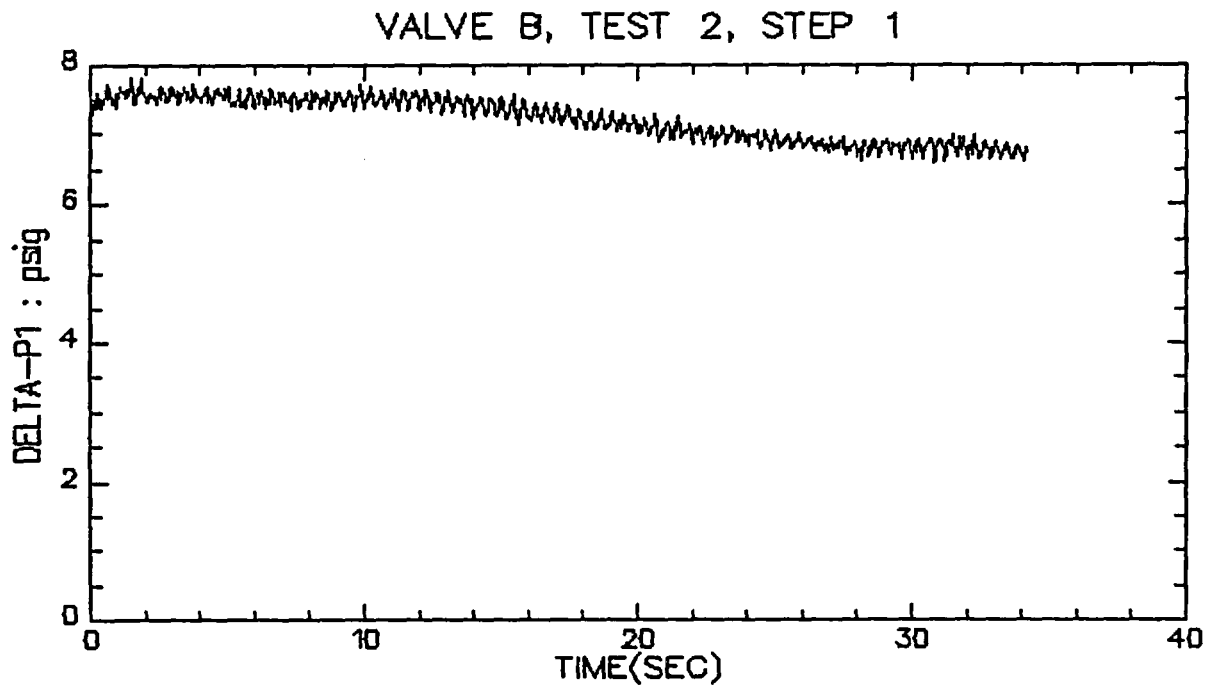
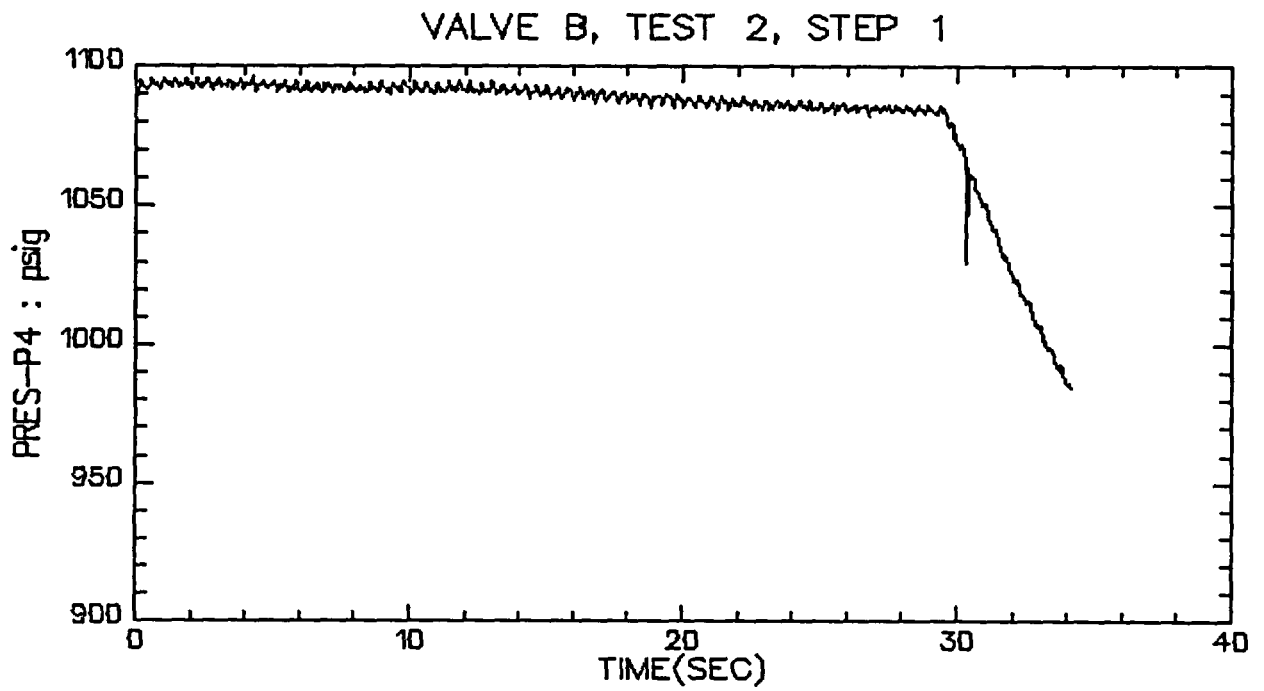

VALVE B, TEST 2, STEP 1

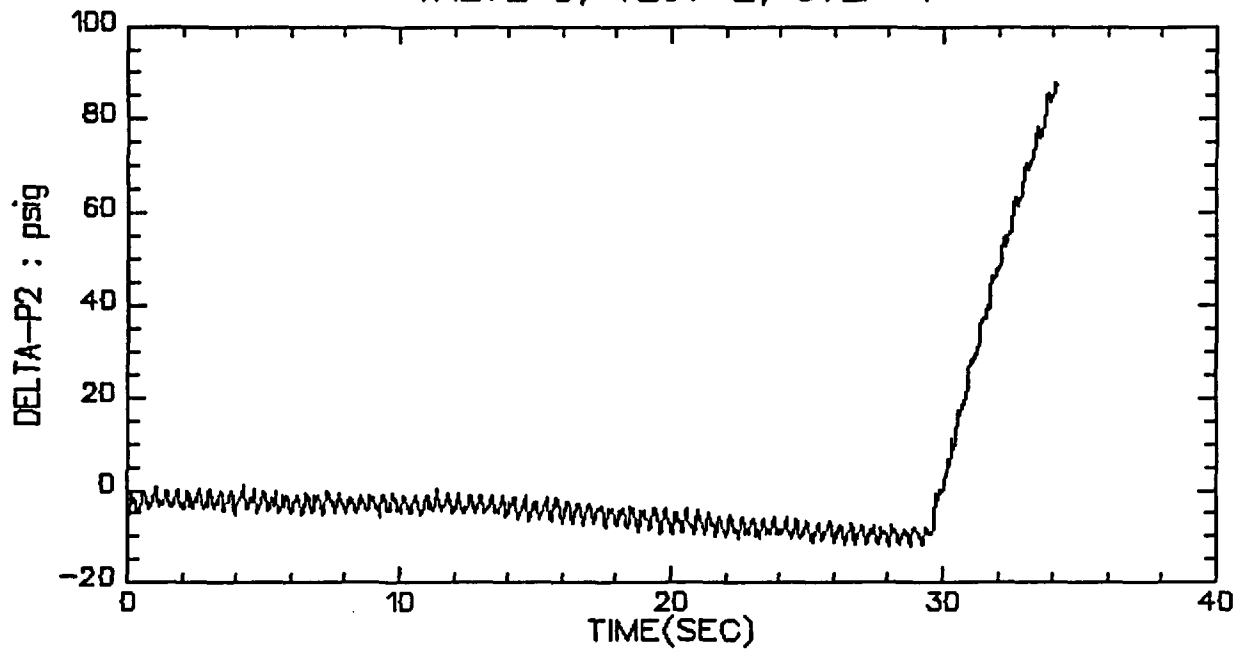

VALVE B, TEST 2, STEP 1

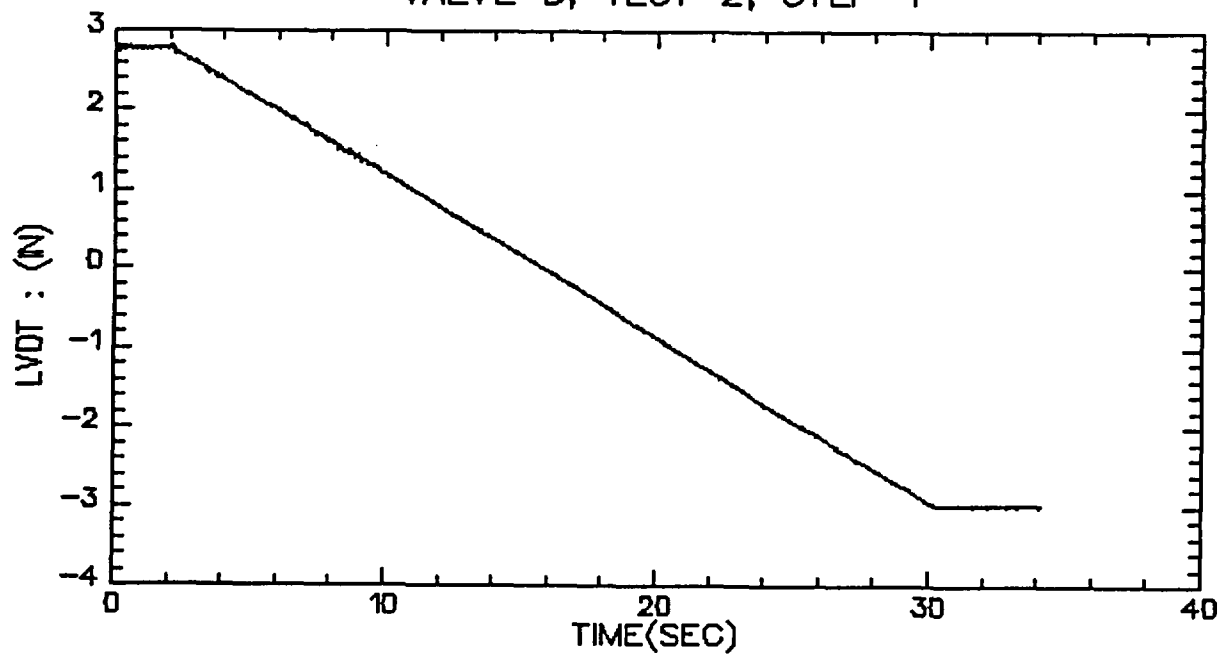

VALVE B, TEST 2, STEP 1

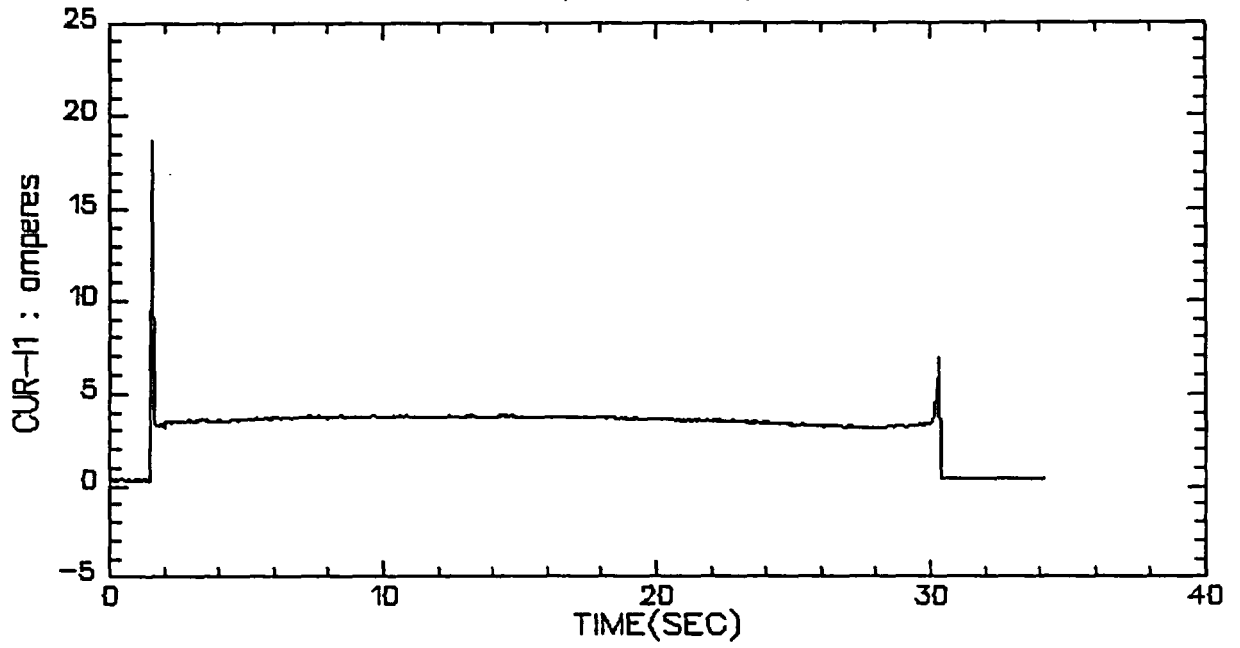

VALVE B, TEST 2, STEP 1

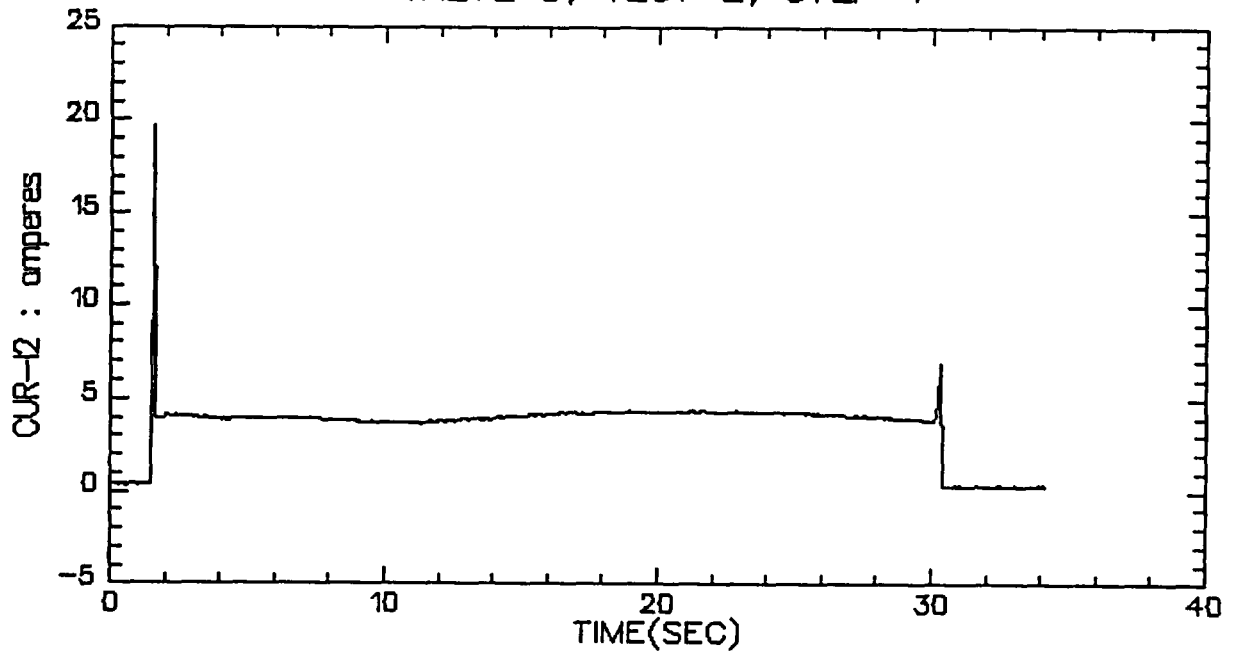

VALVE B, TEST 2, STEP 1

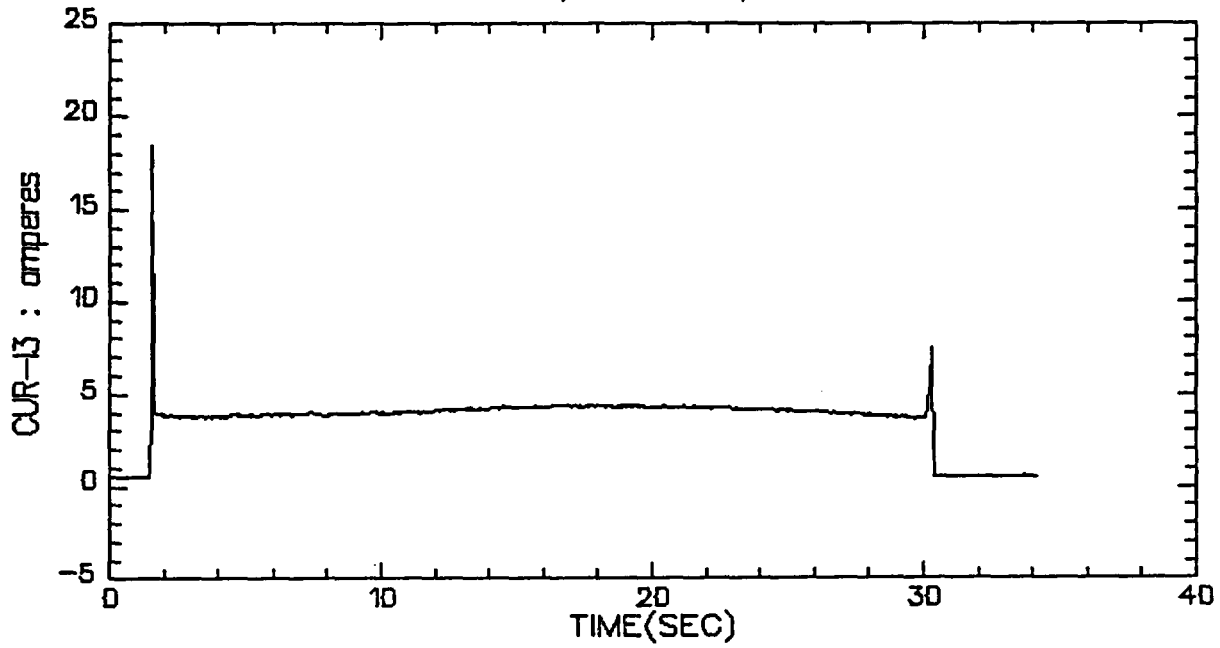

VALVE B, TEST 2, STEP 1

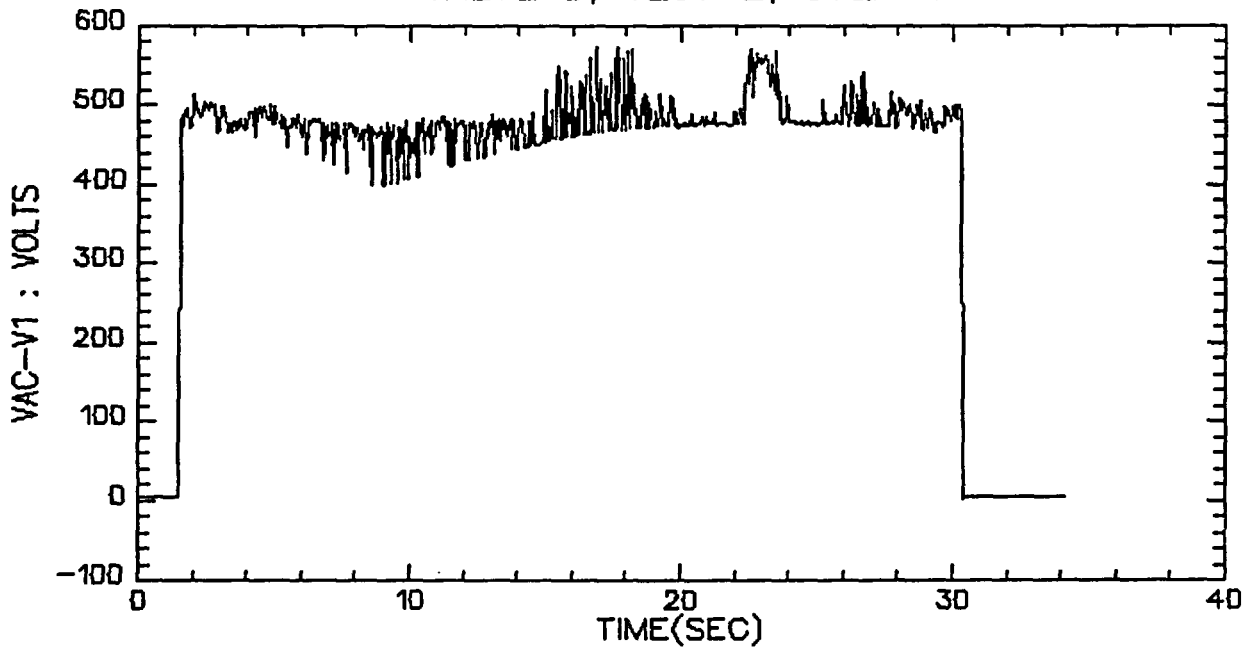

VALVE B, TEST 2, STEP 1

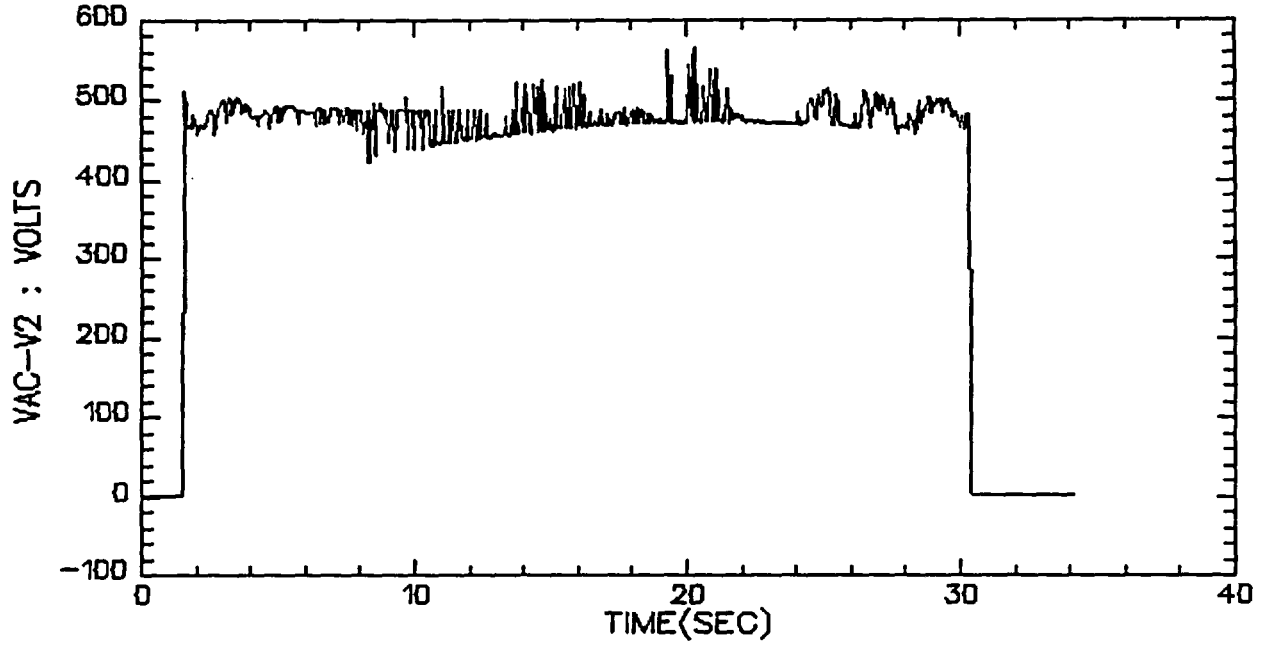

VALVE B, TEST 2, STEP 1

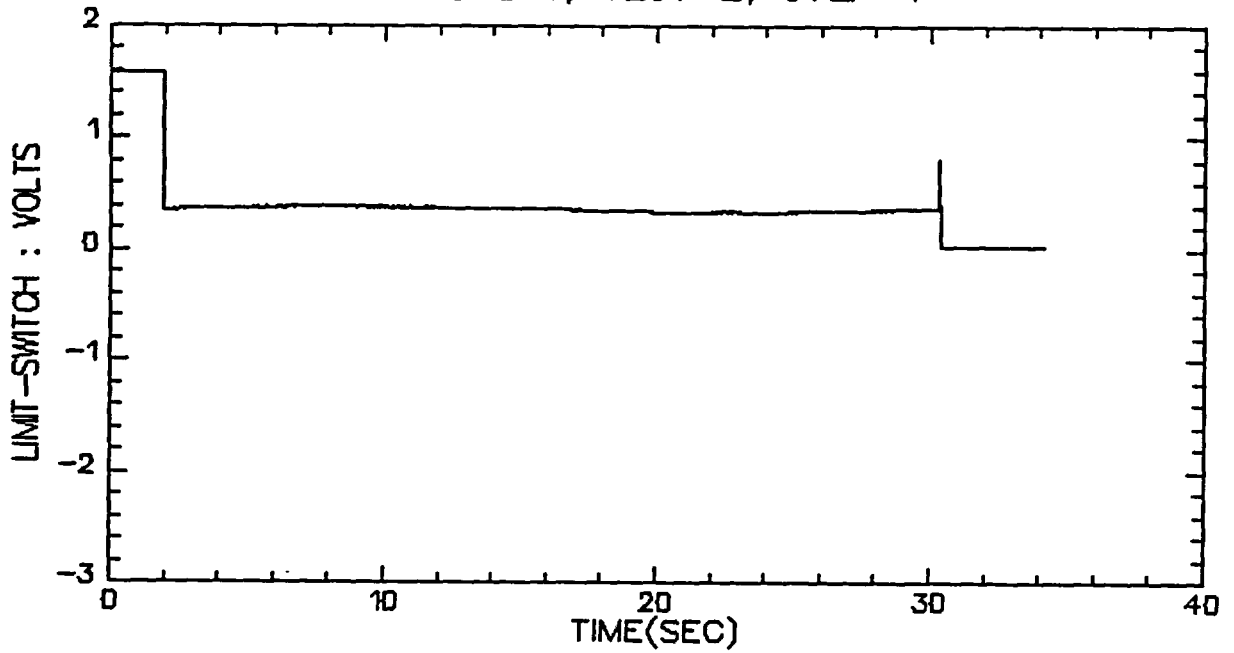

VALVE B, TEST 2, STEP 1

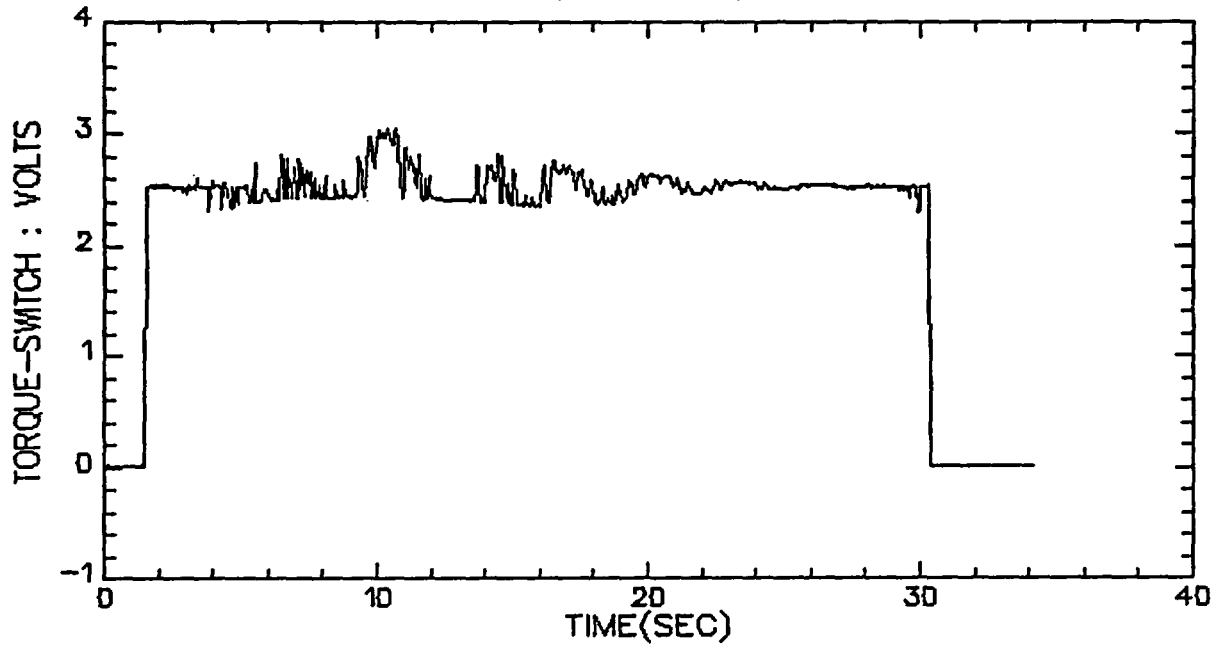

VALVE B, TEST 2, STEP 1

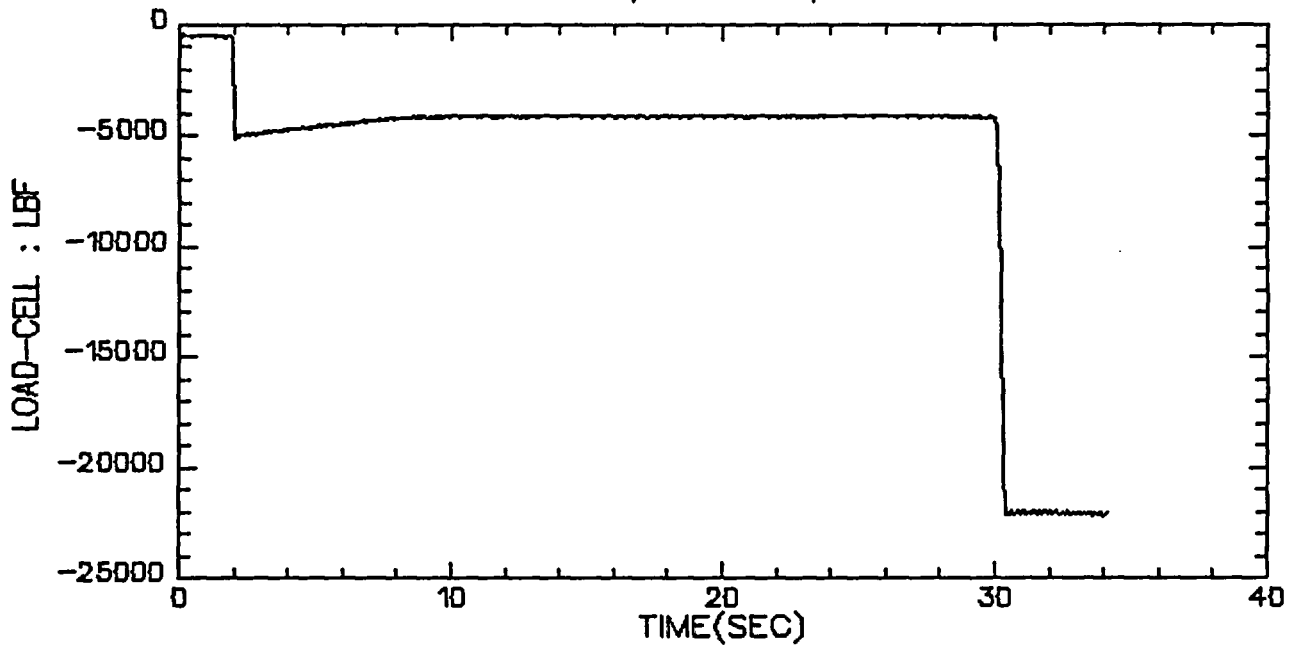

VALVE B, TEST 2, STEP 2

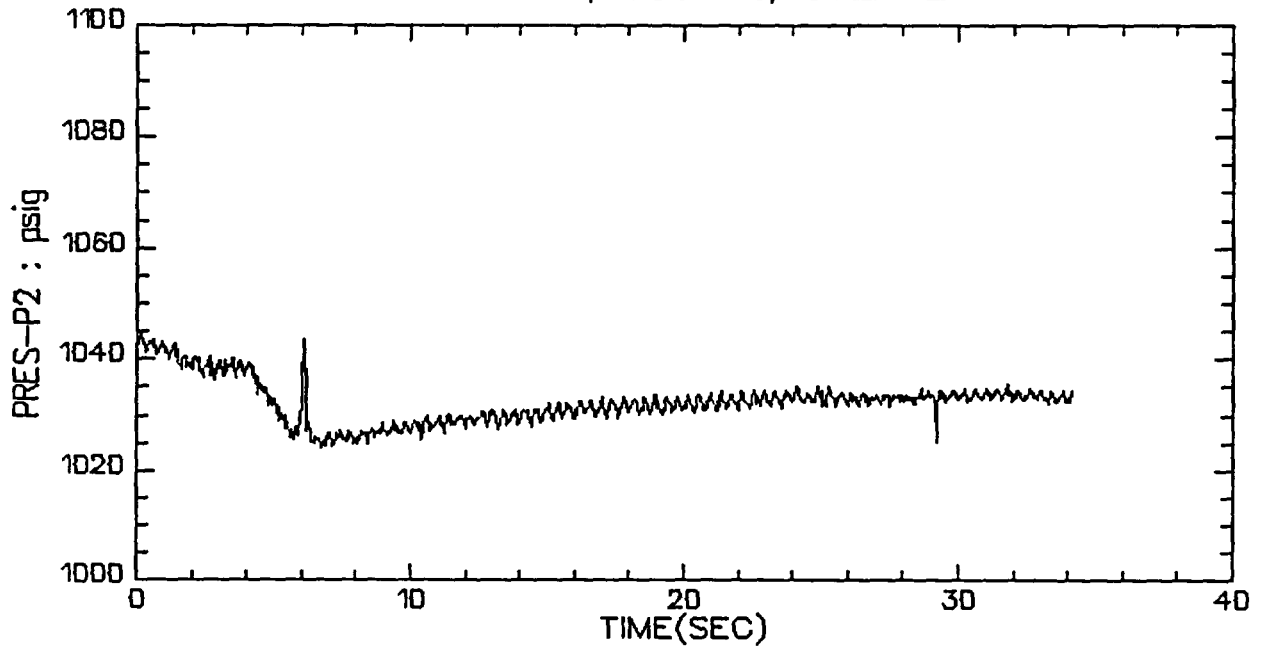

VALVE B, TEST 2, STEP 2

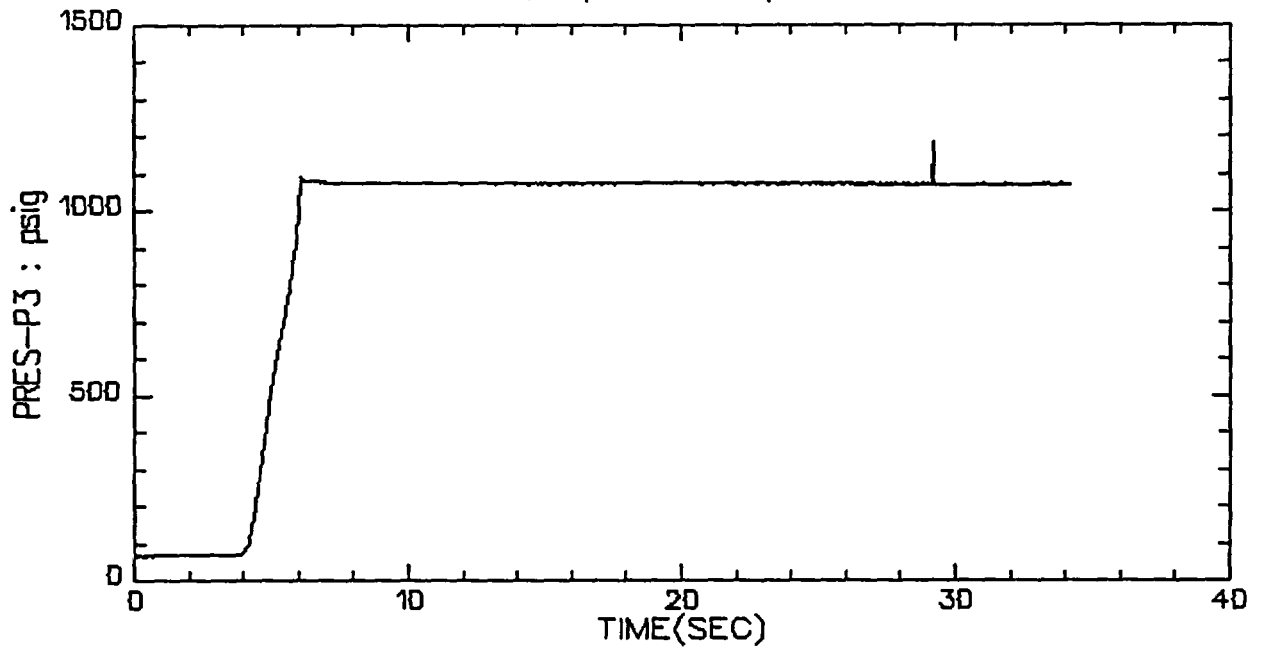

VALVE B, TEST 2, STEP 2

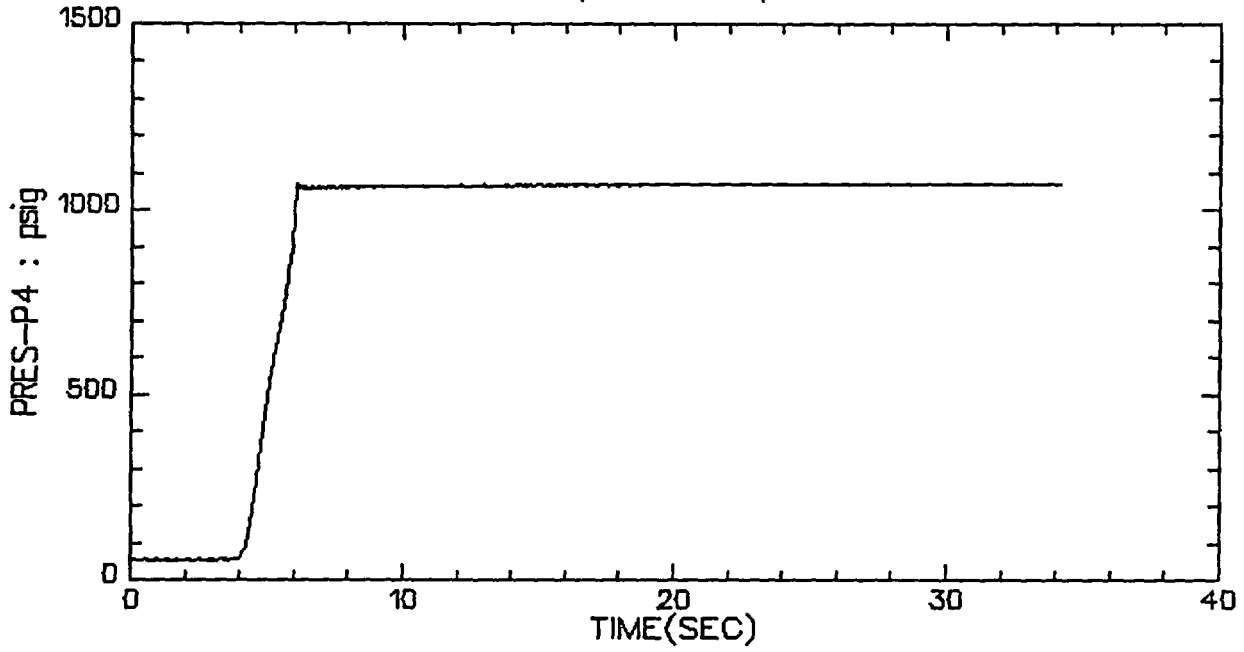

VALVE B, TEST 2, STEP 2

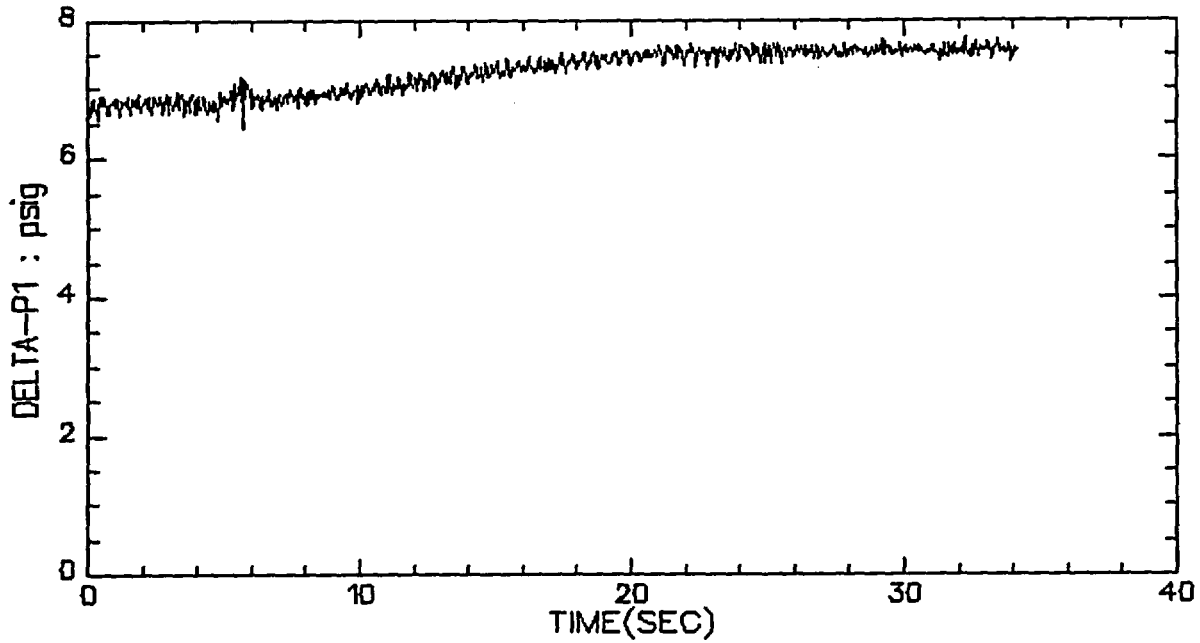

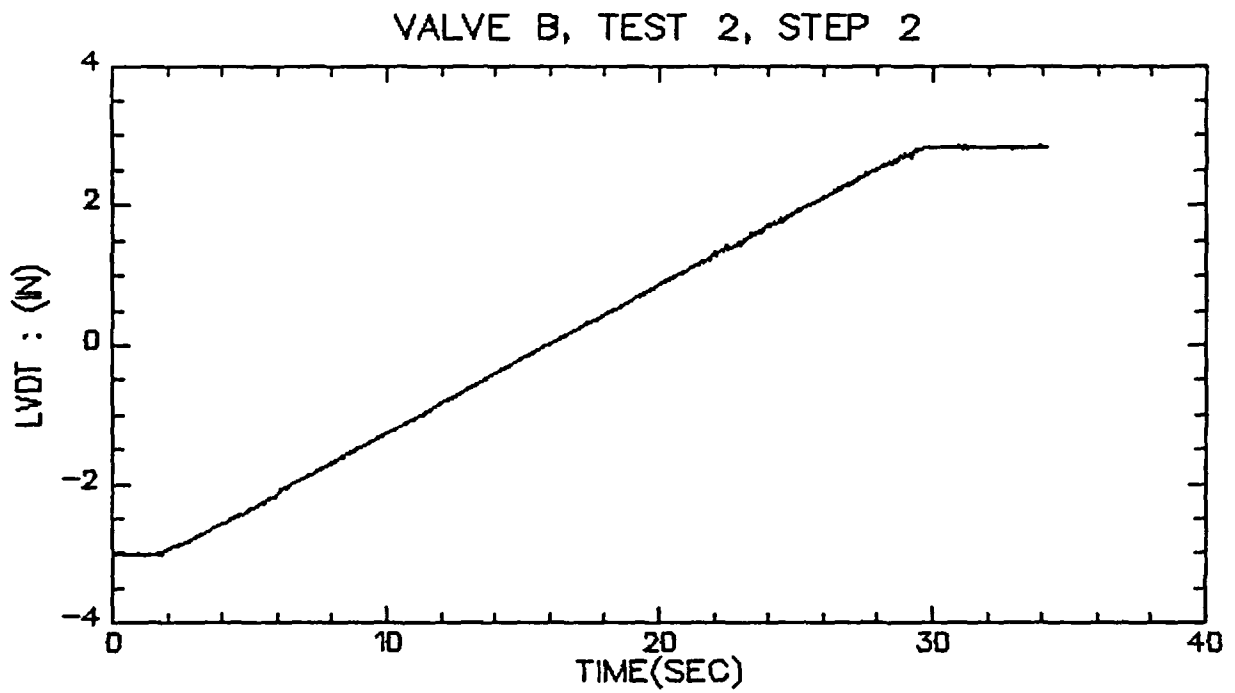
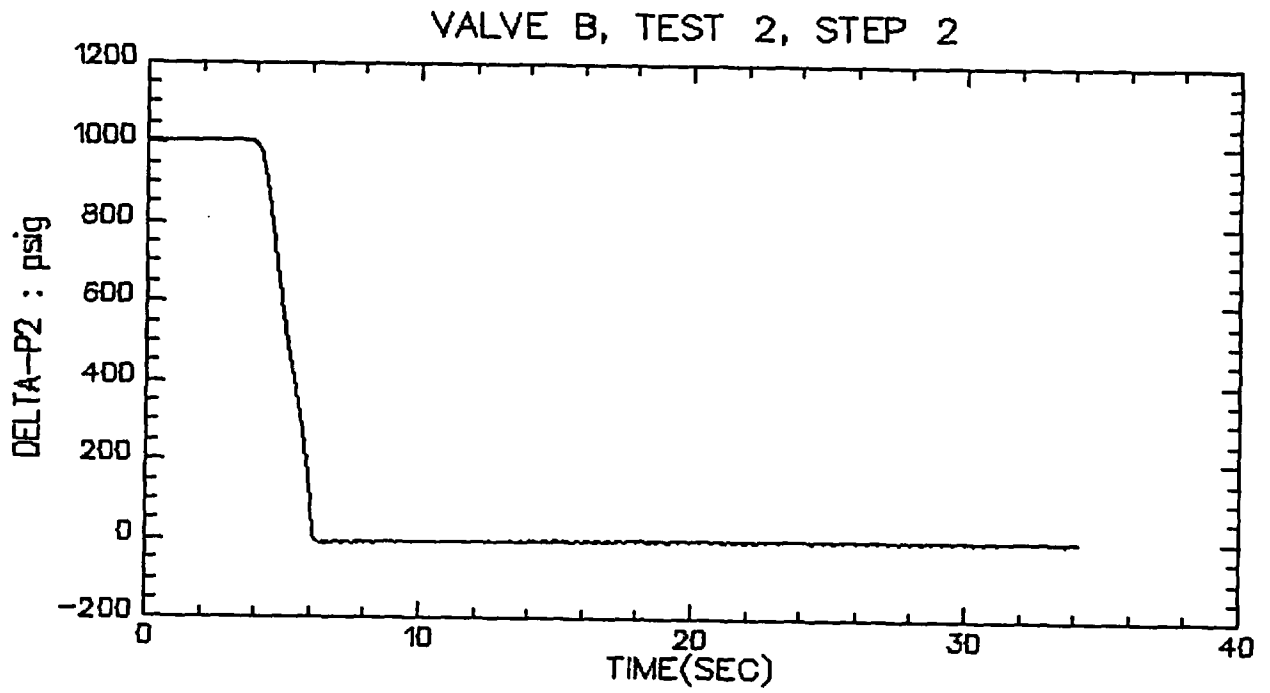

VALVE B, TEST 2, STEP 2

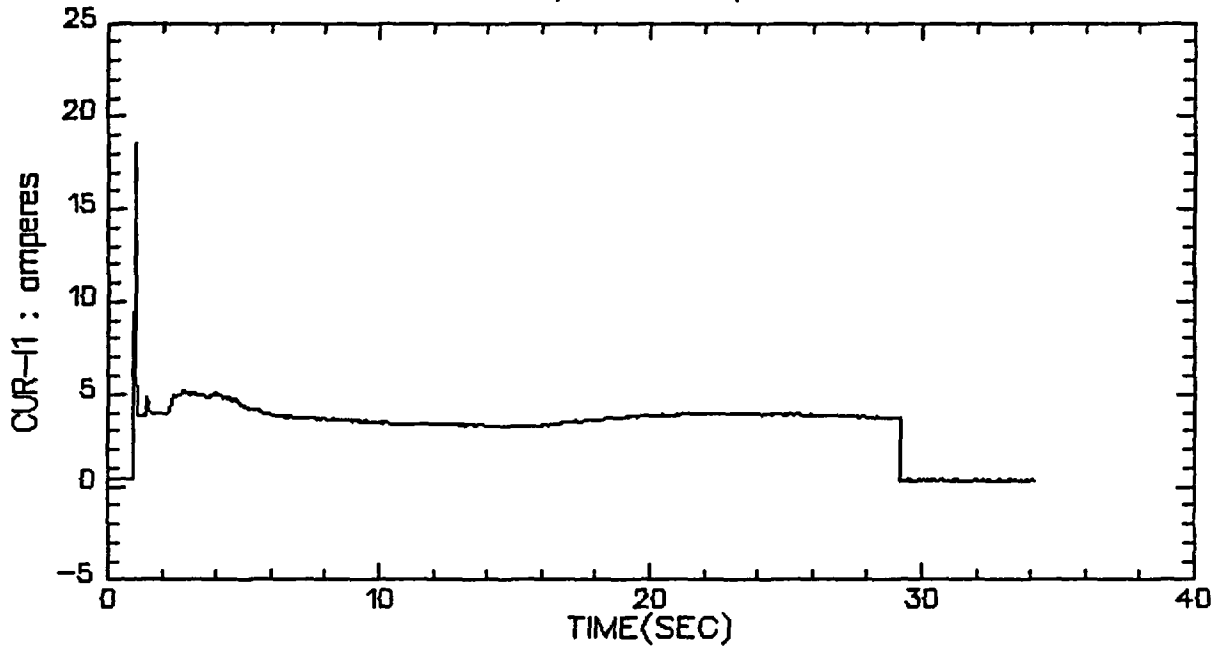

VALVE B, TEST 2, STEP 2

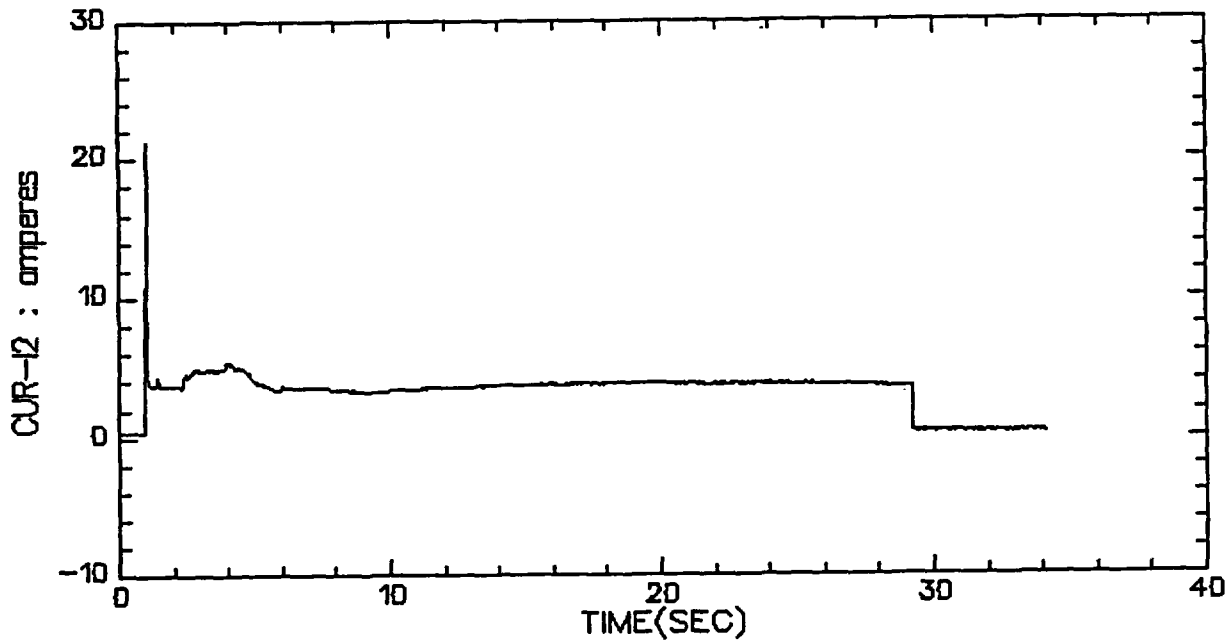

VALVE B, TEST 2, STEP 2

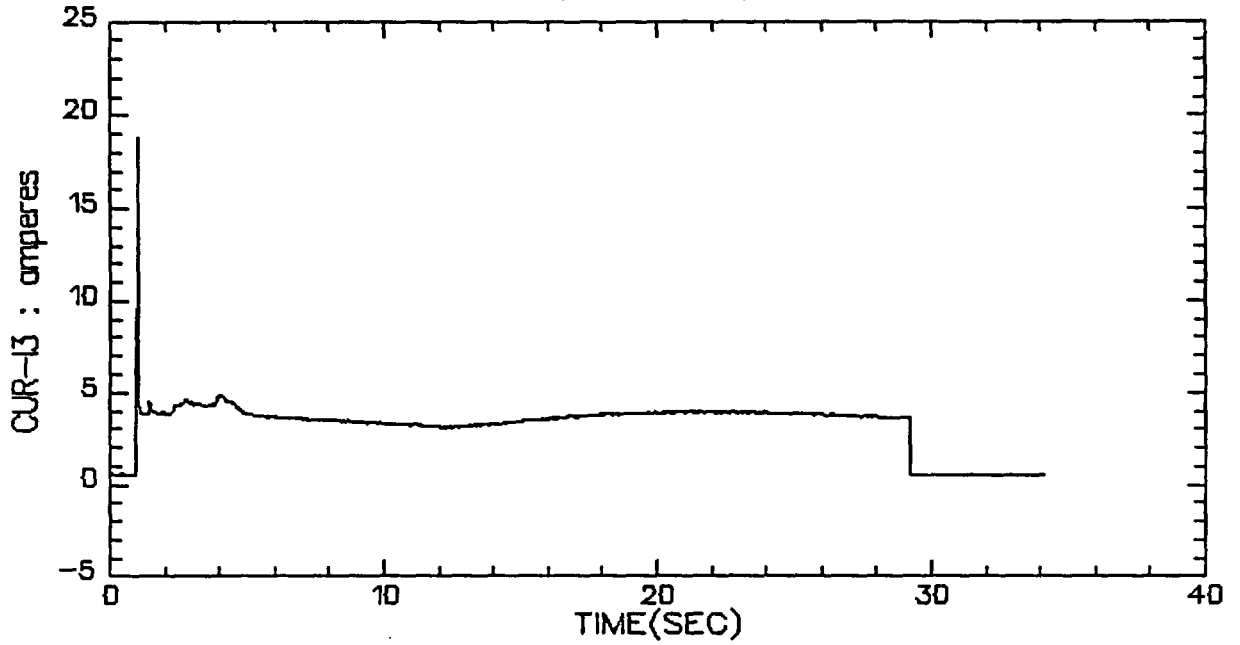

VALVE B, TEST 2, STEP 2

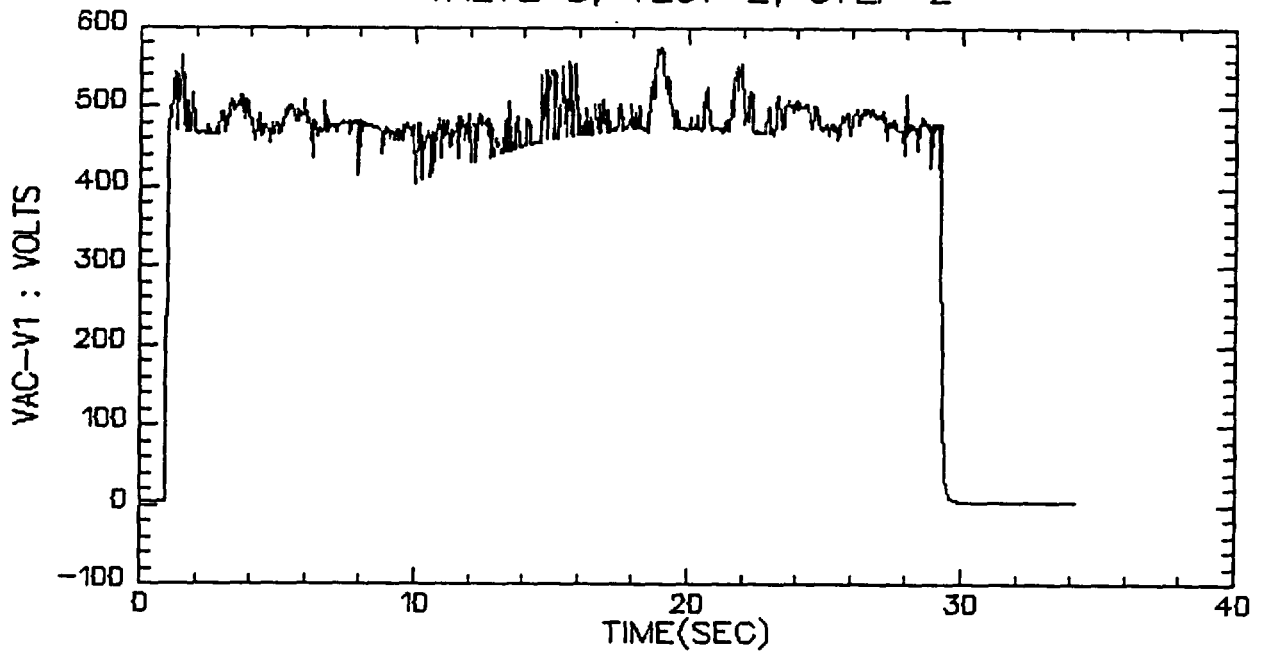

VALVE B, TEST 2, STEP 2

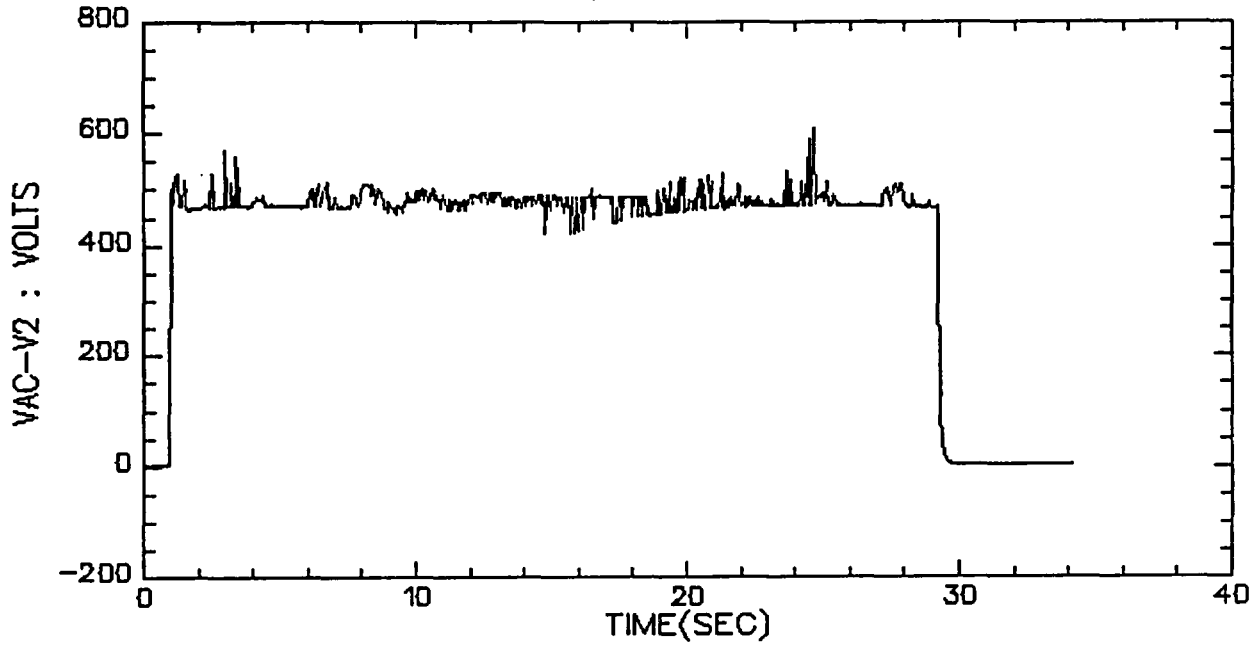

VALVE B, TEST 2, STEP 2

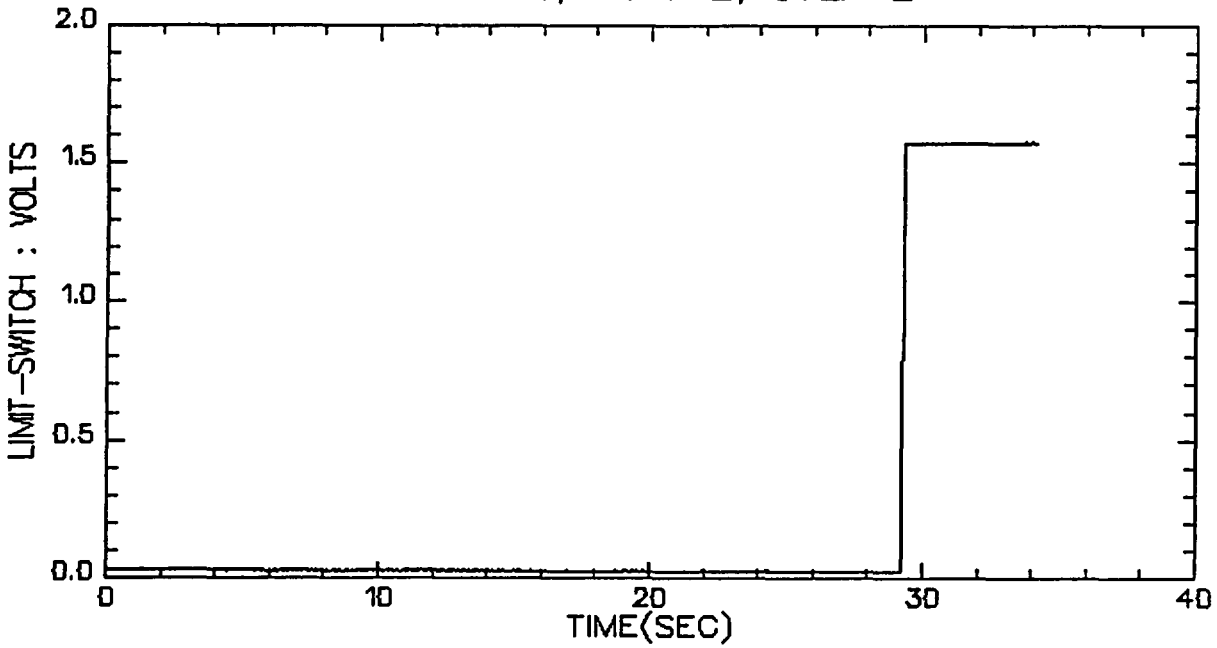

VALVE B, TEST 2, STEP 2

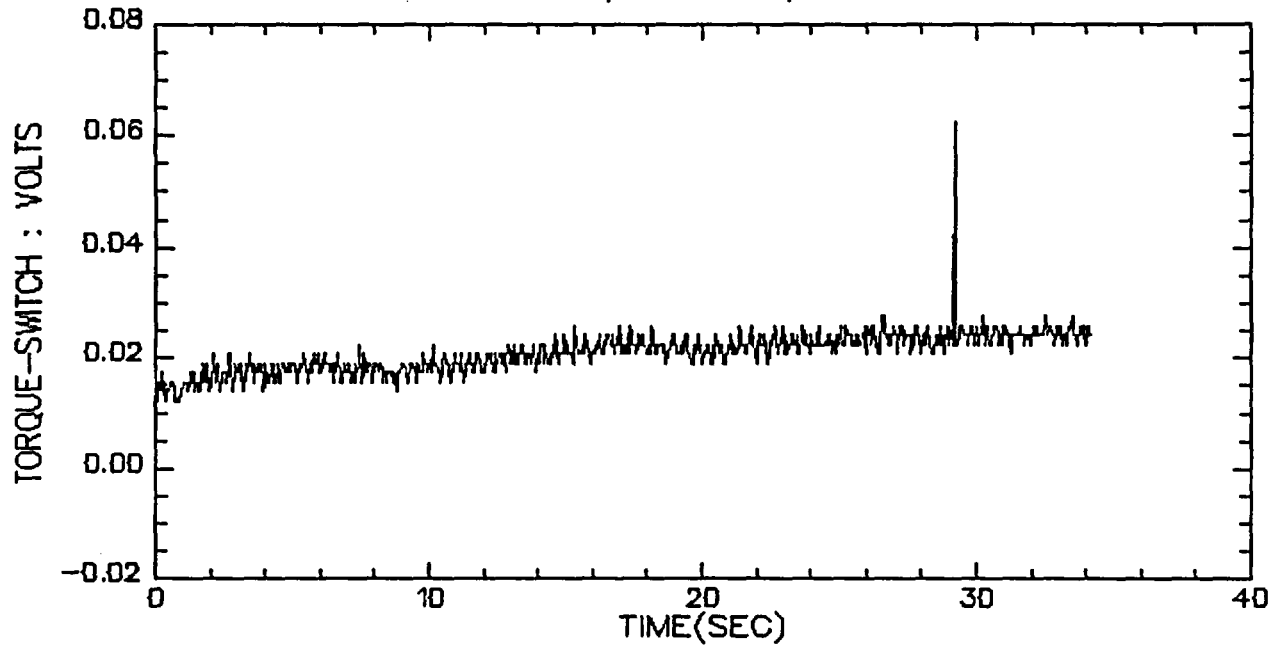

VALVE B, TEST 2, STEP 2

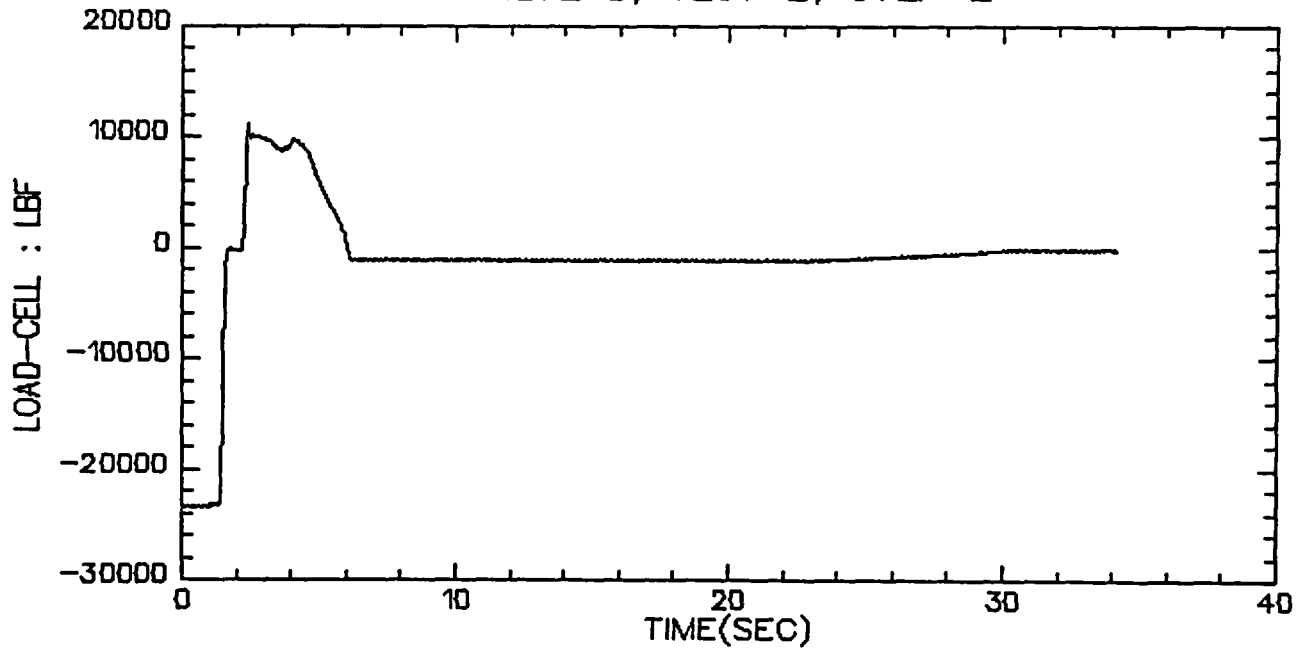

VALVE B, TEST 2, STEP 3&4

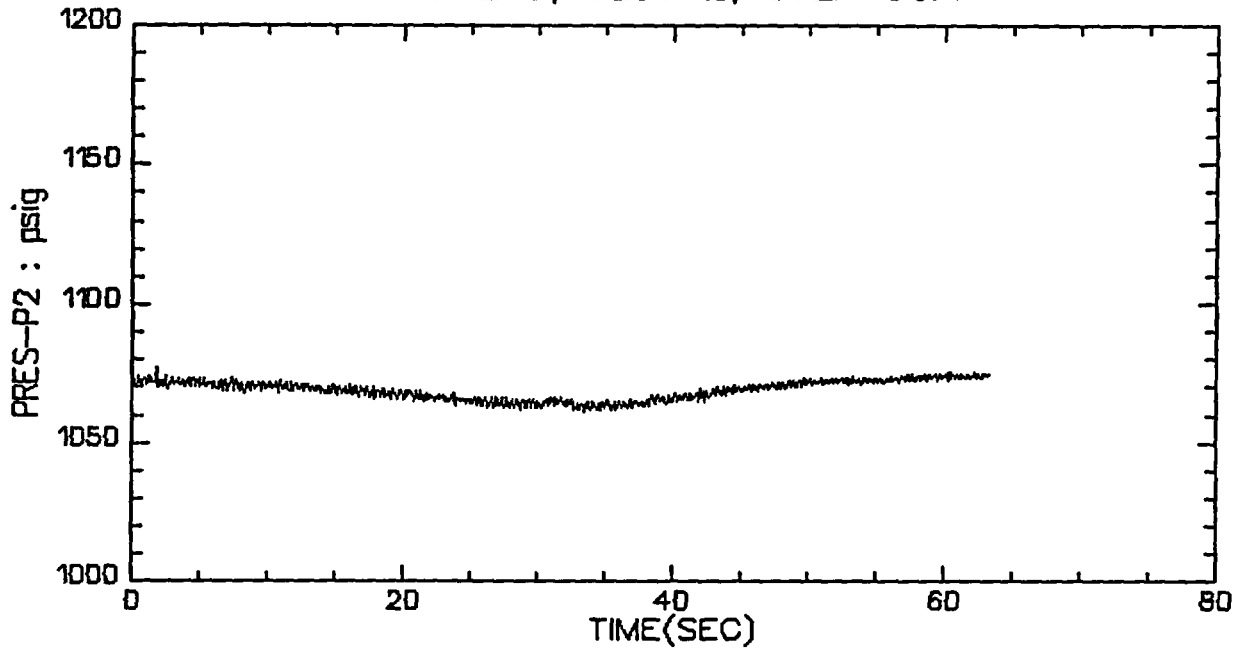

VALVE B, TEST 2, STEP 3&4

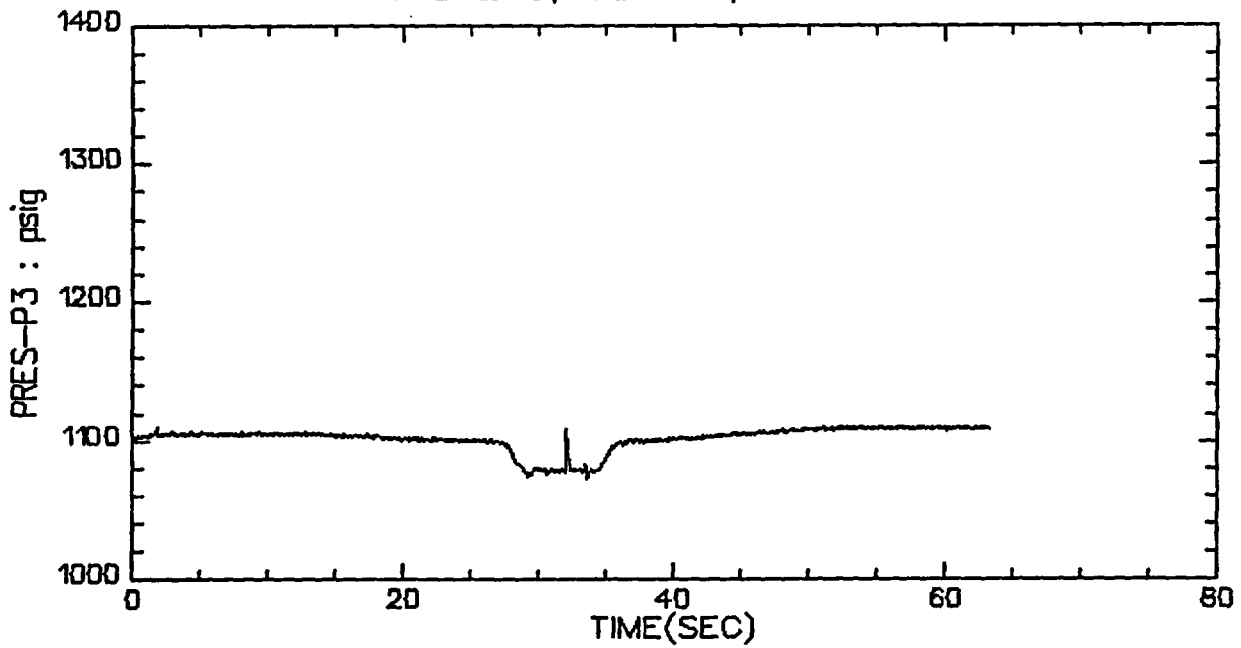

VALVE B, TEST 2, STEP 3&4

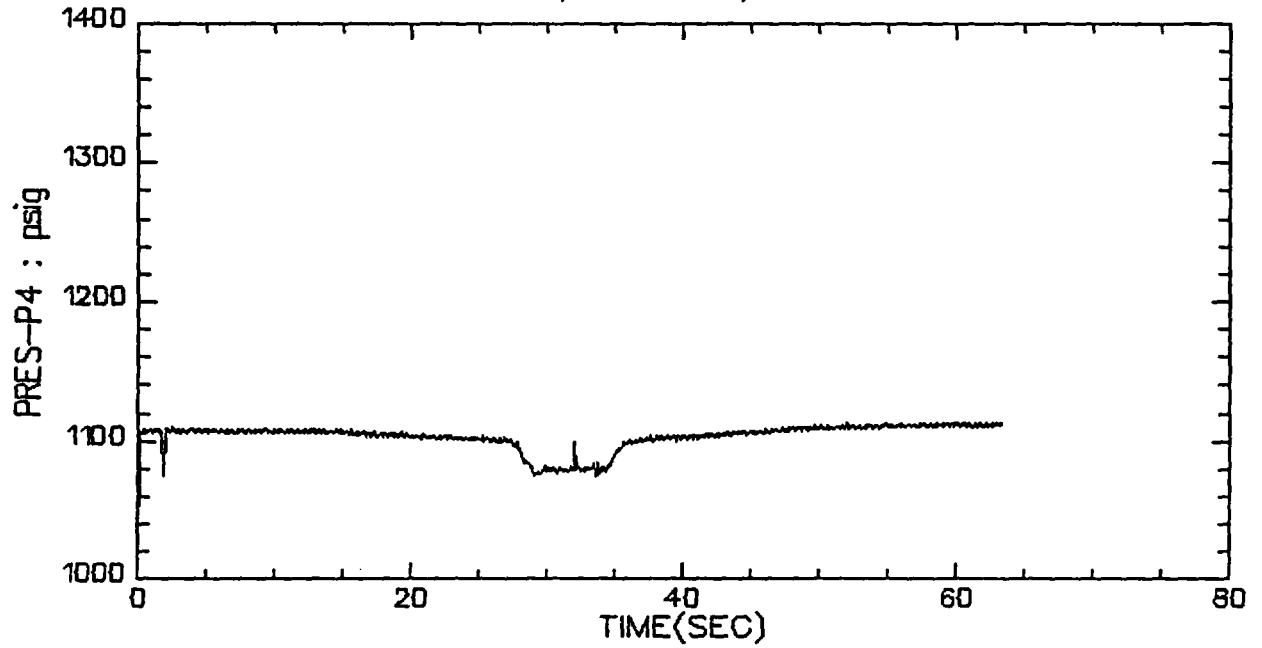

VALVE B, TEST 2, STEP 3&4

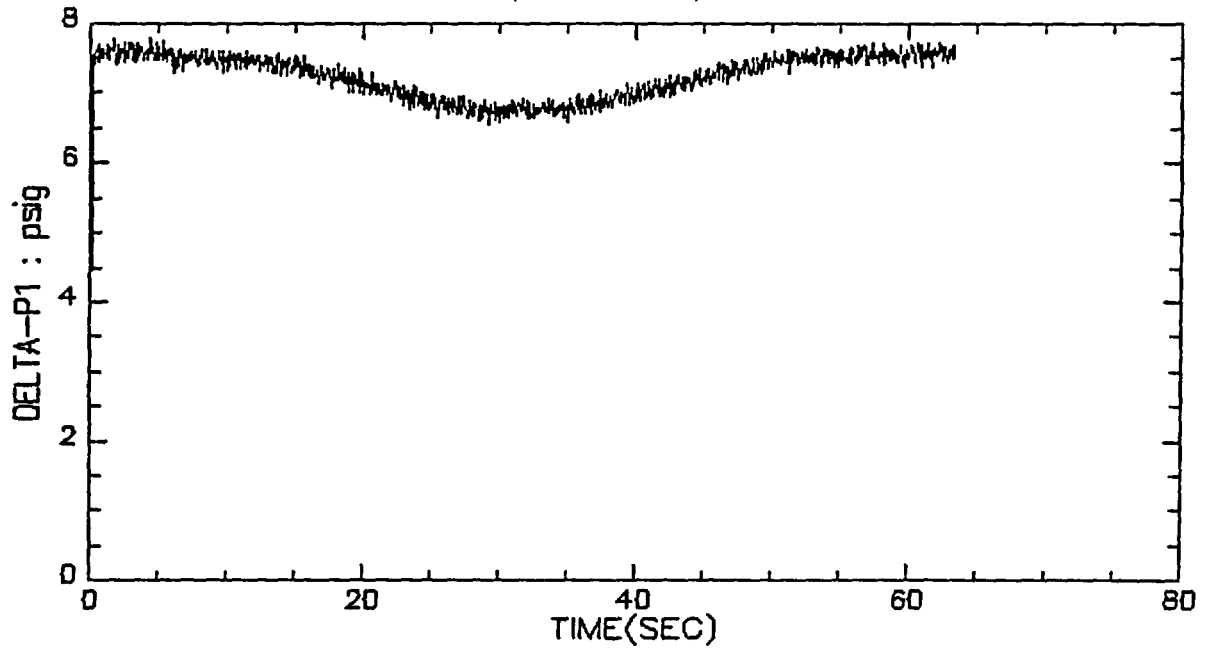

VALVE B, TEST 2, STEP 3&4

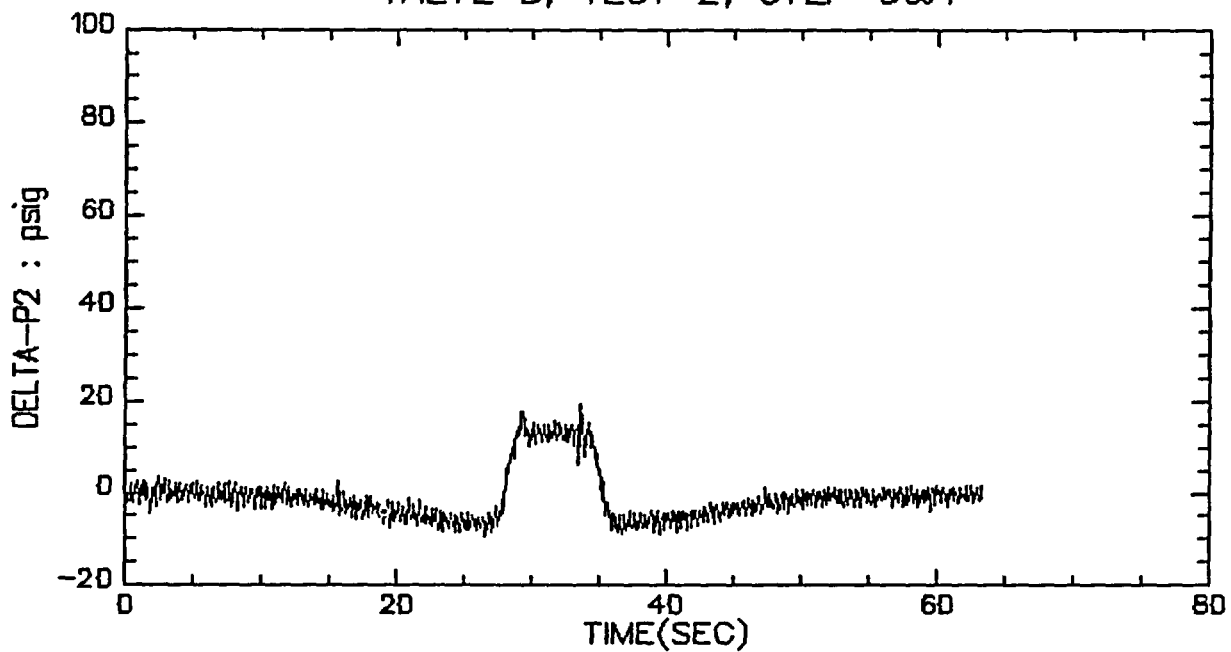

VALVE B, TEST 2, STEP 3&4

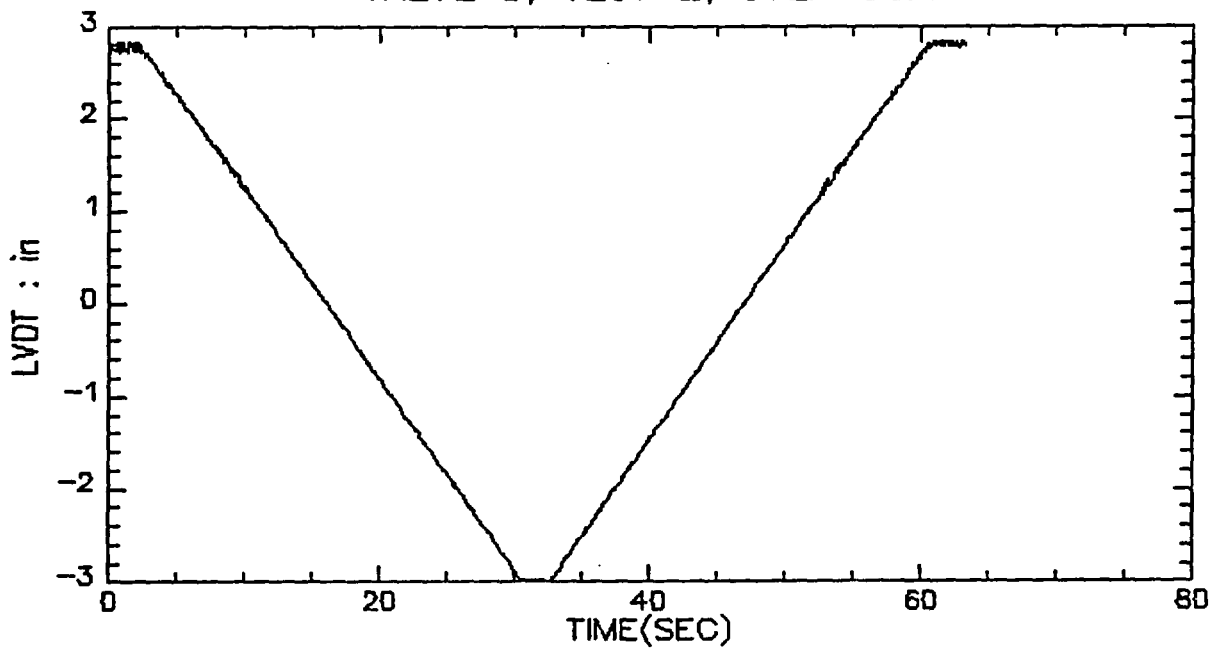

VALVE B, TEST 2, STEP 3&4

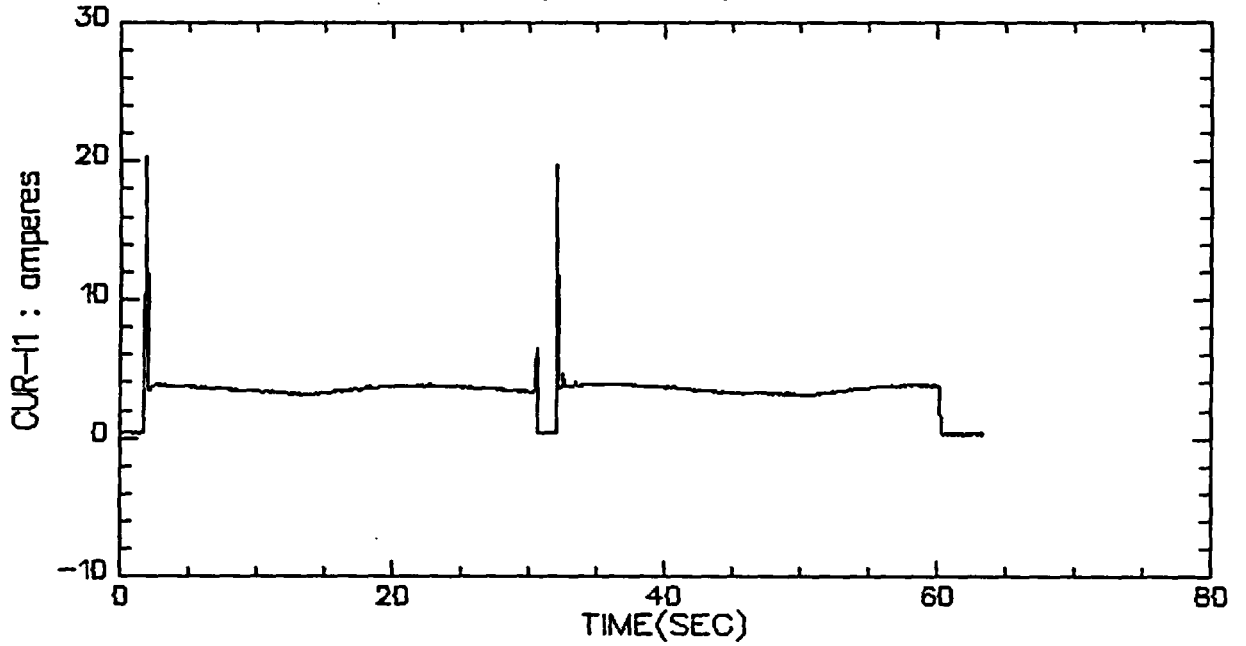

VALVE B, TEST 2, STEP 3&4

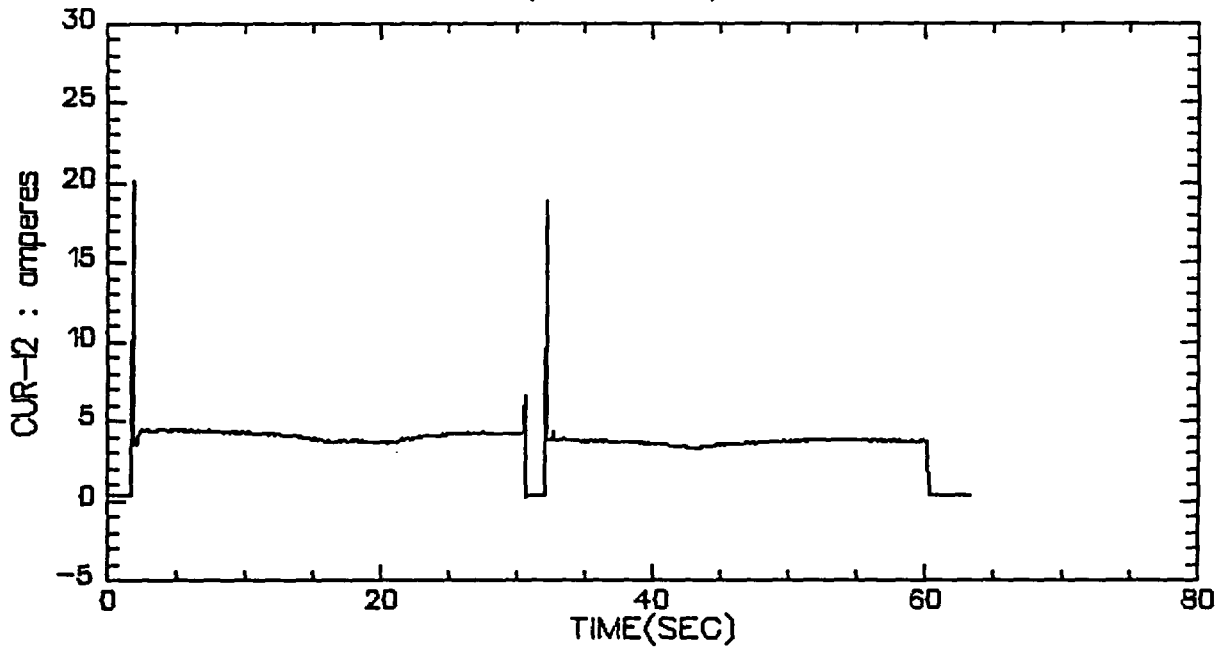

VALVE B, TEST 2, STEP 3&4

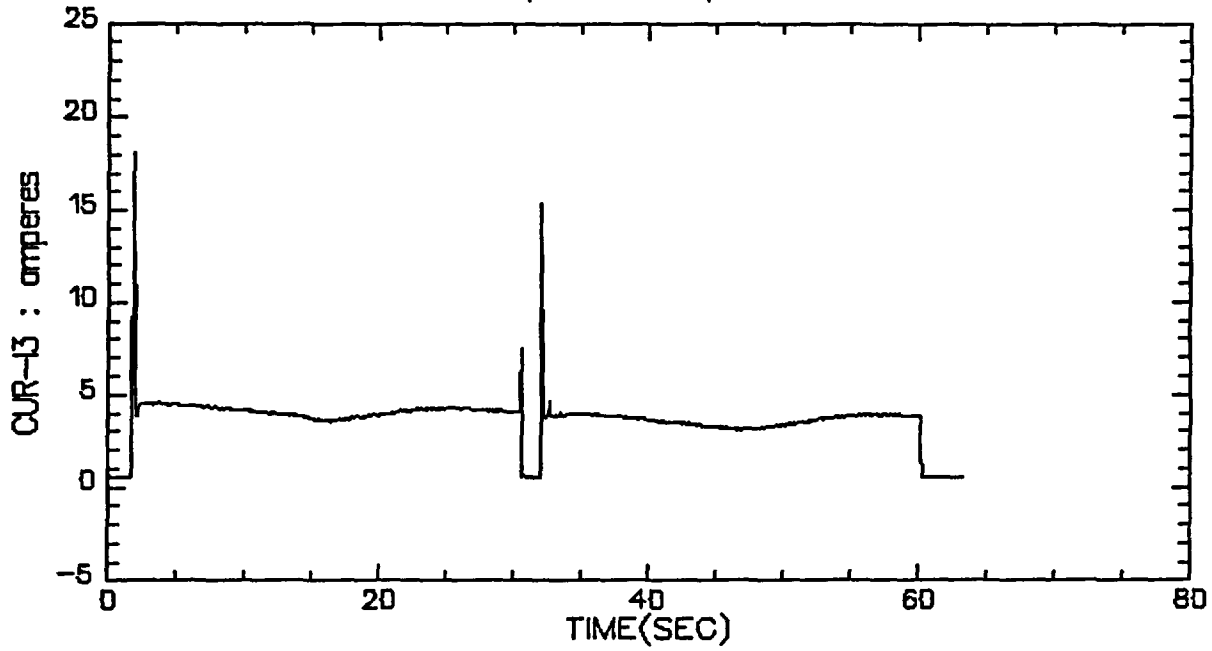

VALVE B, TEST 2, STEP 3&4

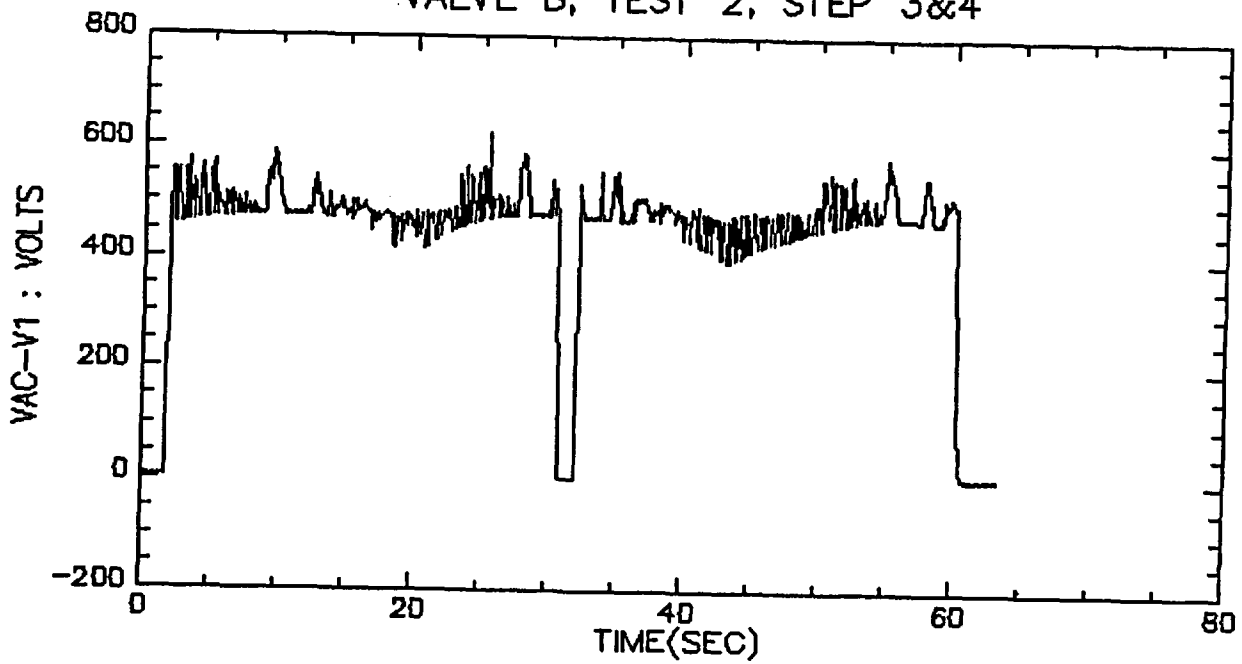

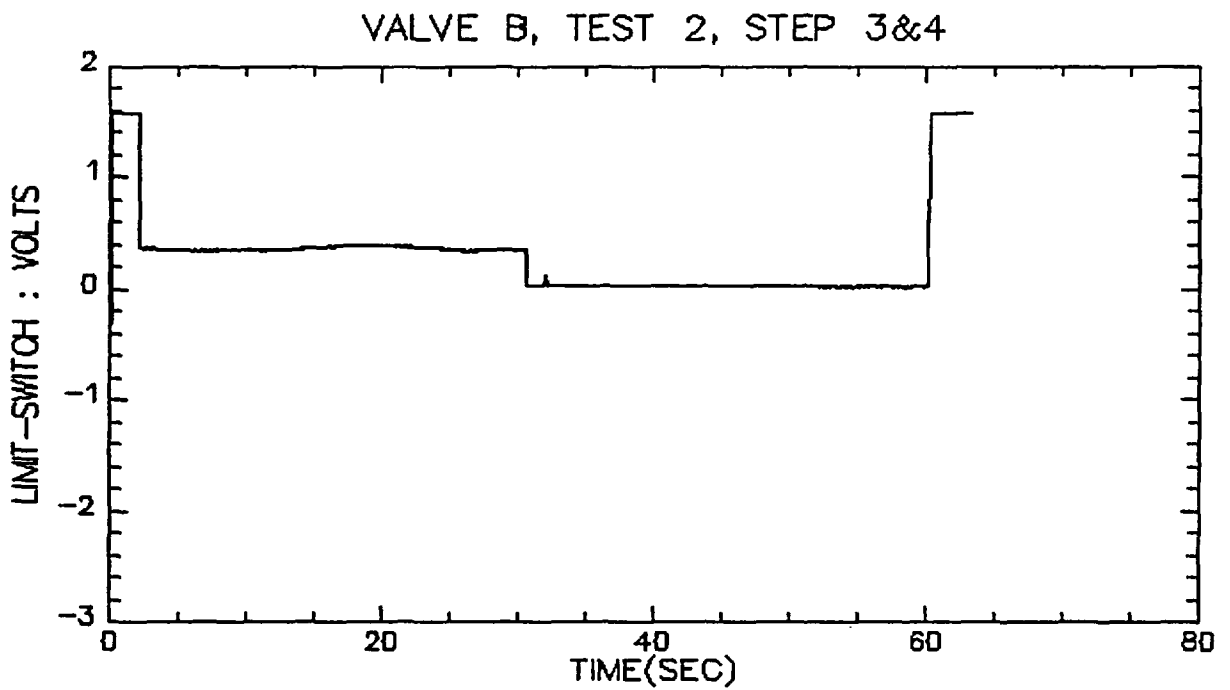
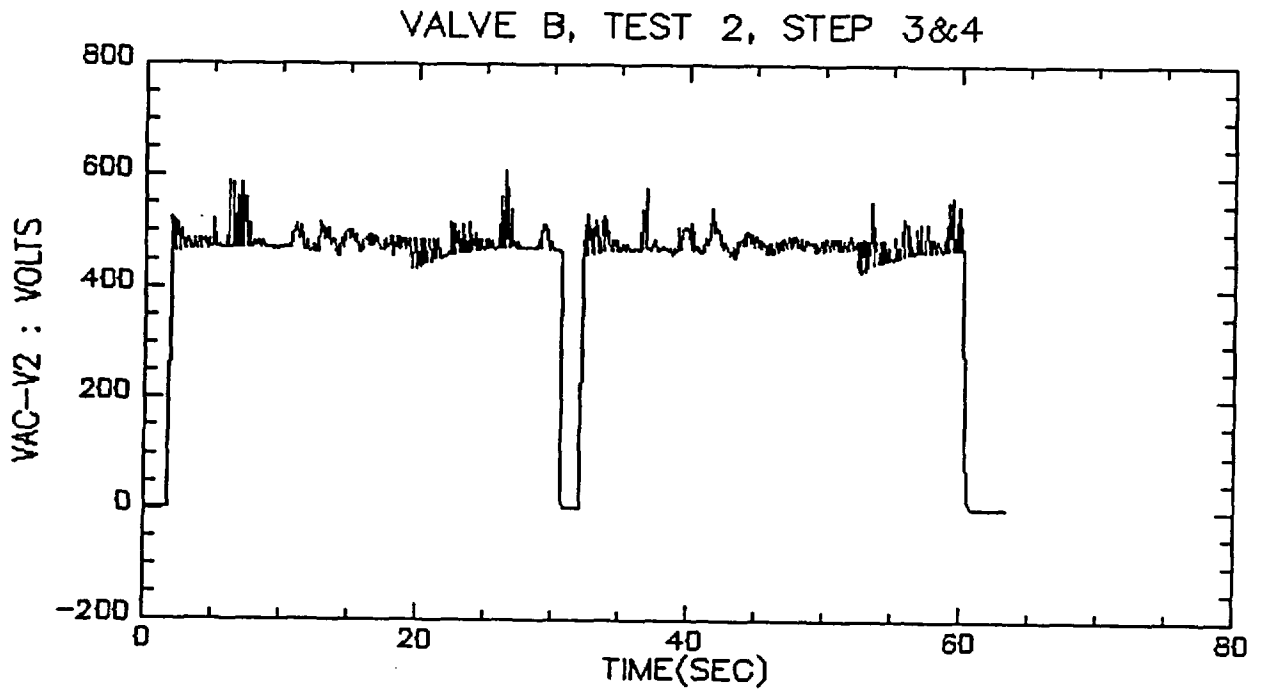

VALVE B, TEST 2, STEP 3&4

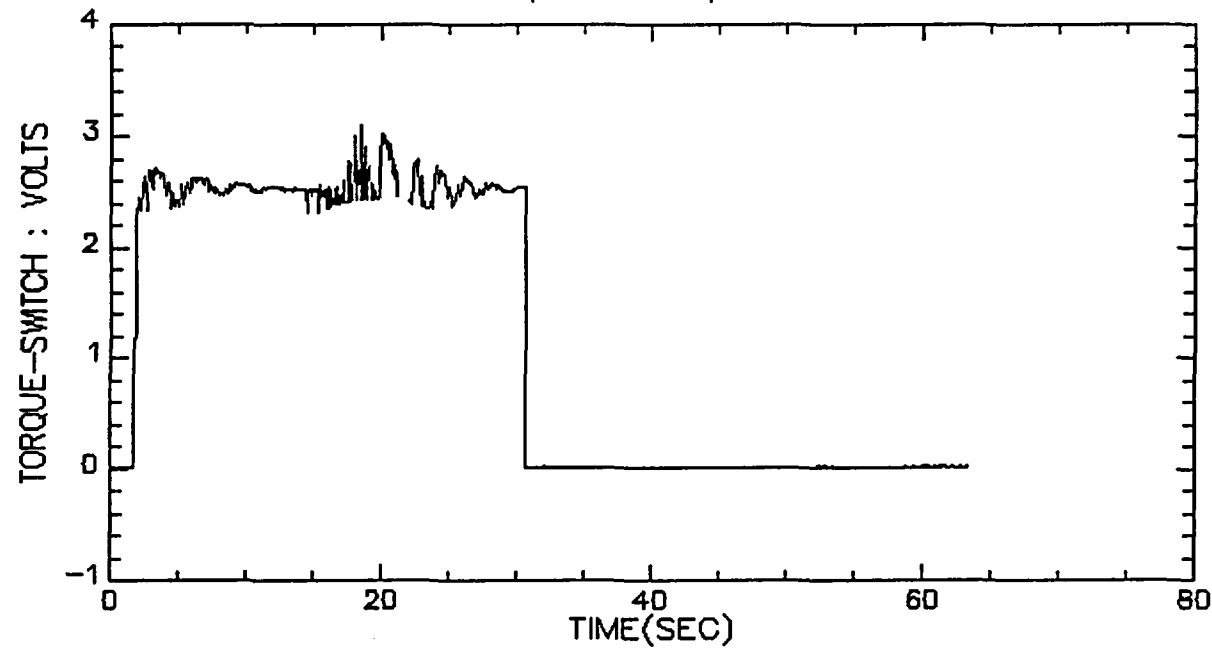

VALVE B, TEST 2, STEP 3&4

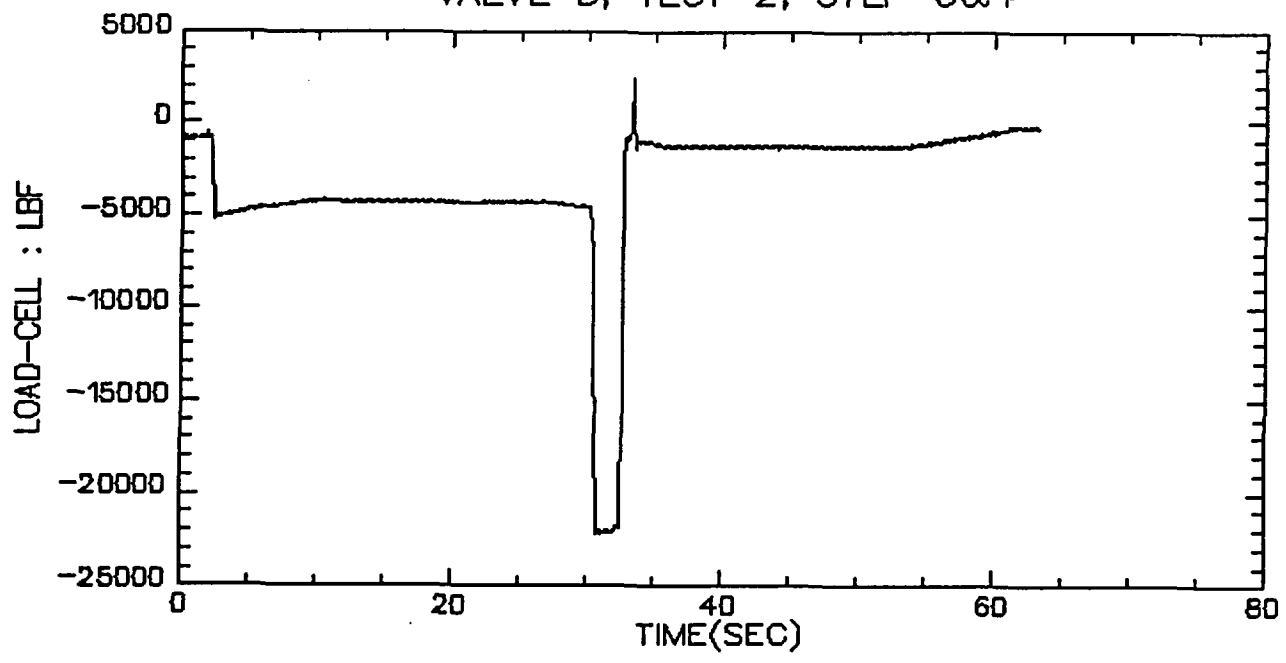

VALVE B, TEST 2, STEP 5

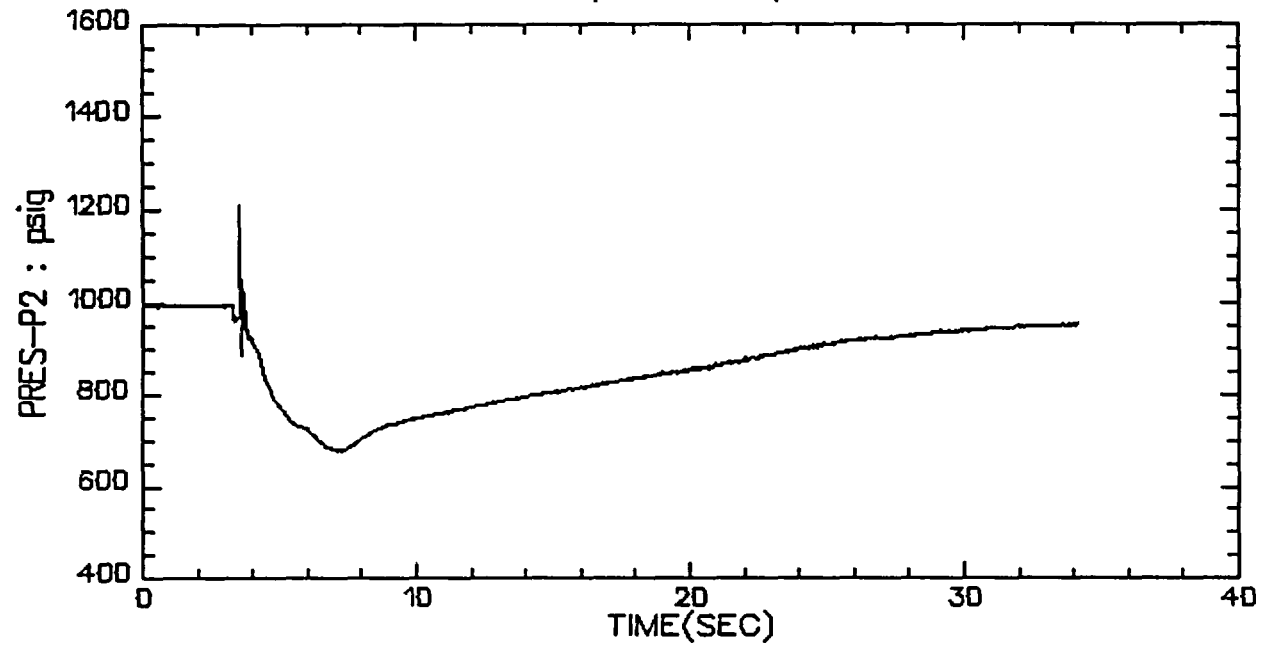

VALVE B, TEST 2, STEP 5

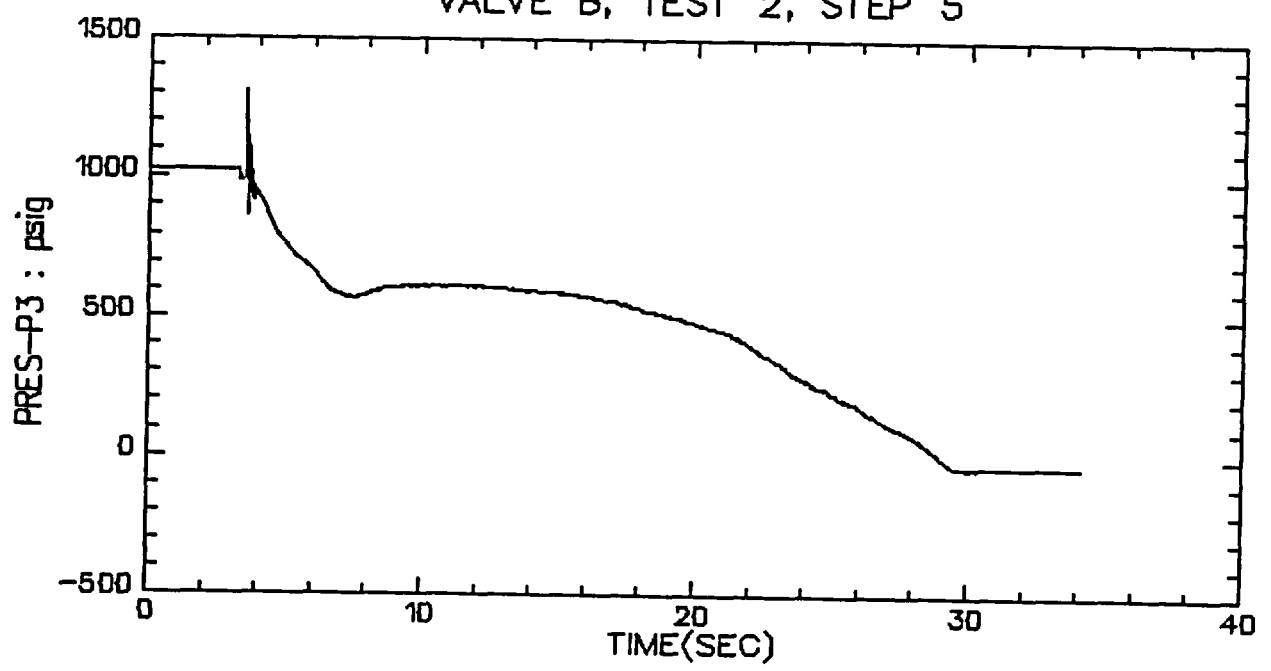

VALVE B, TEST 2, STEP 5

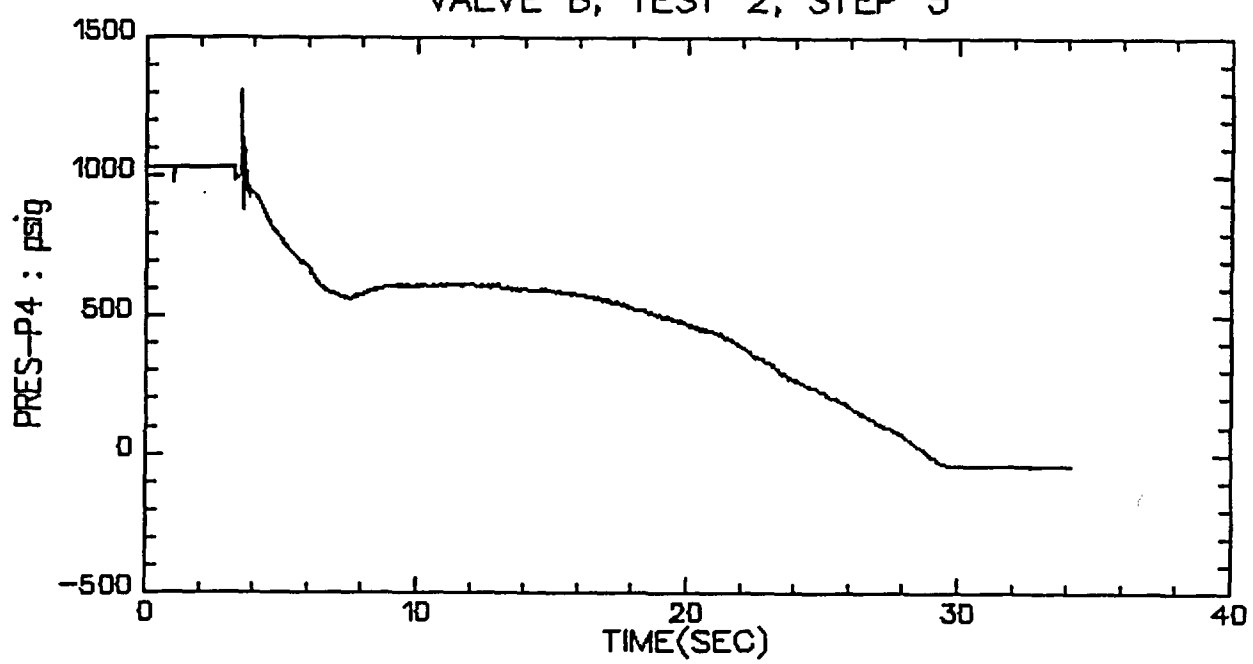

VALVE B, TEST 2, STEP 5

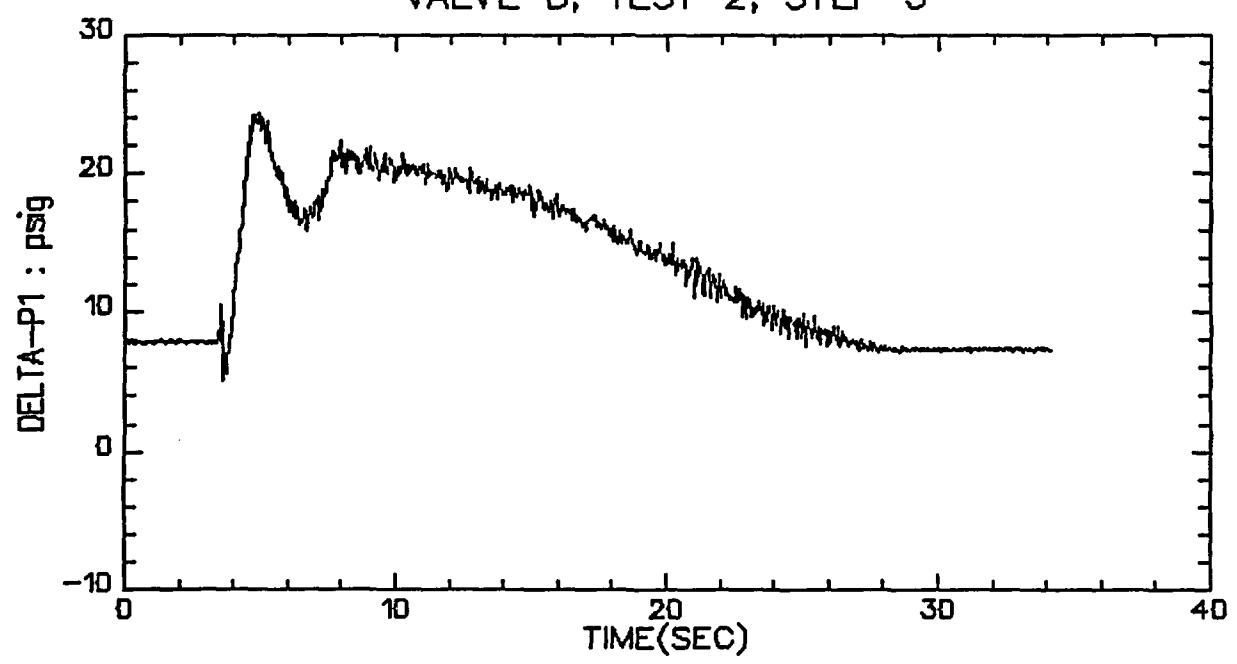

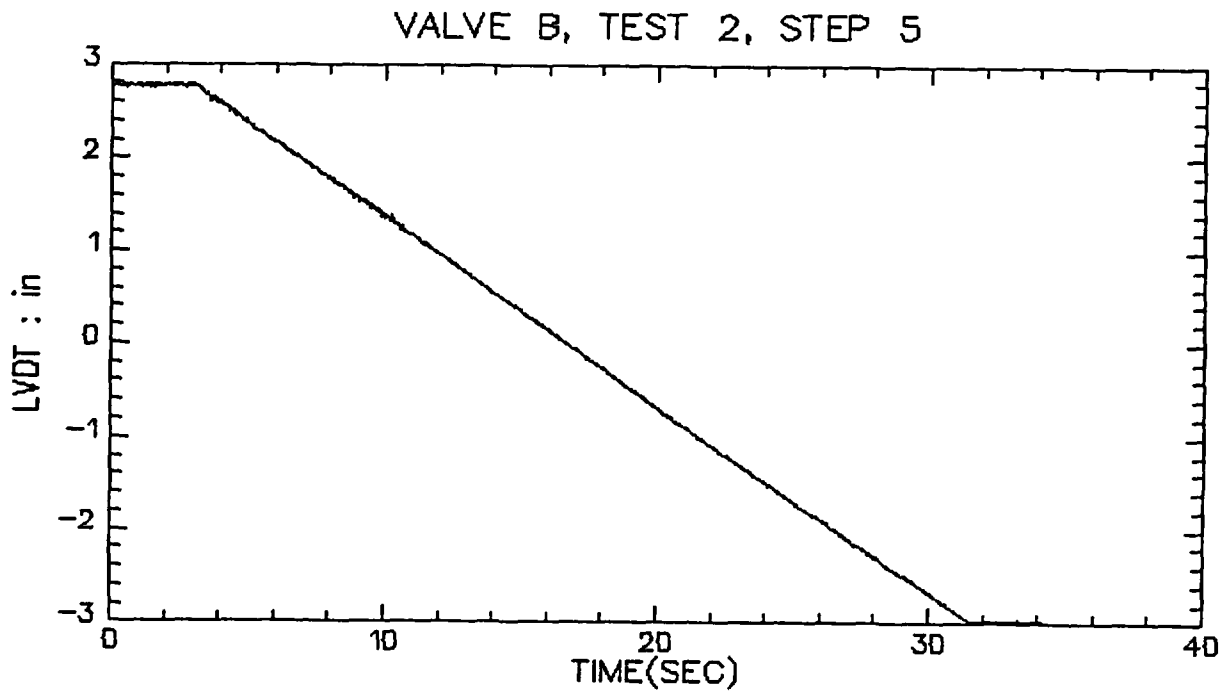
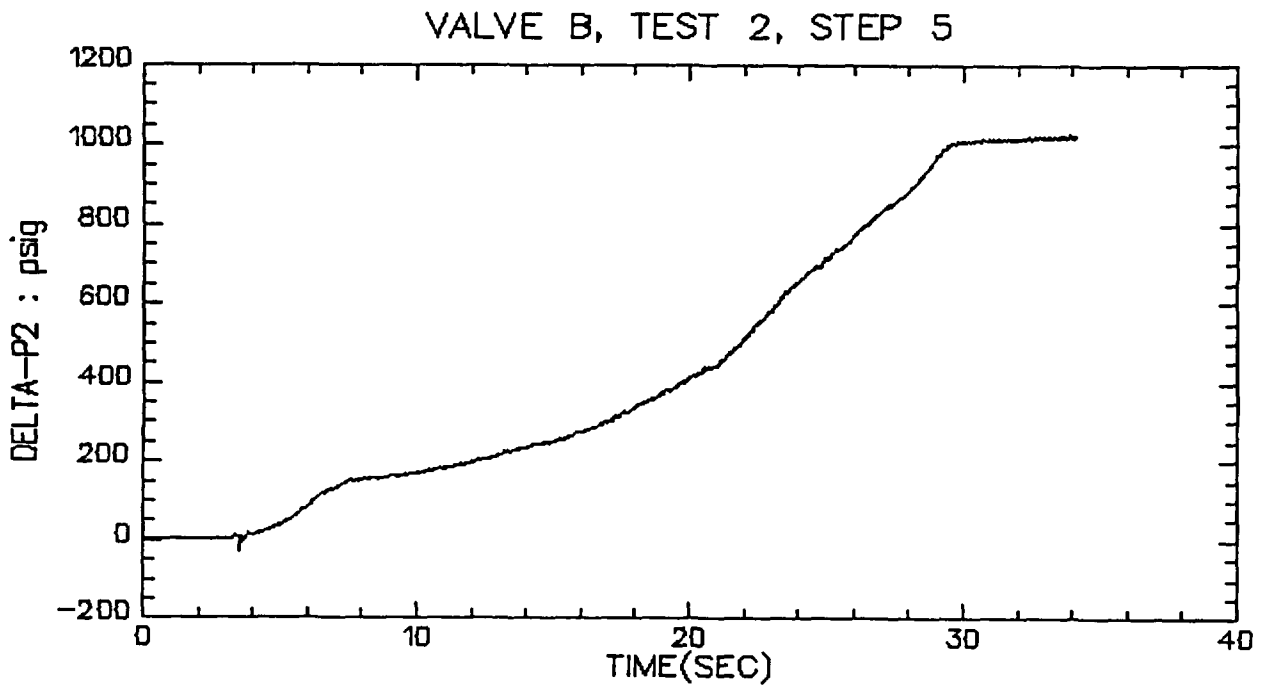

VALVE B, TEST 2, STEP 5

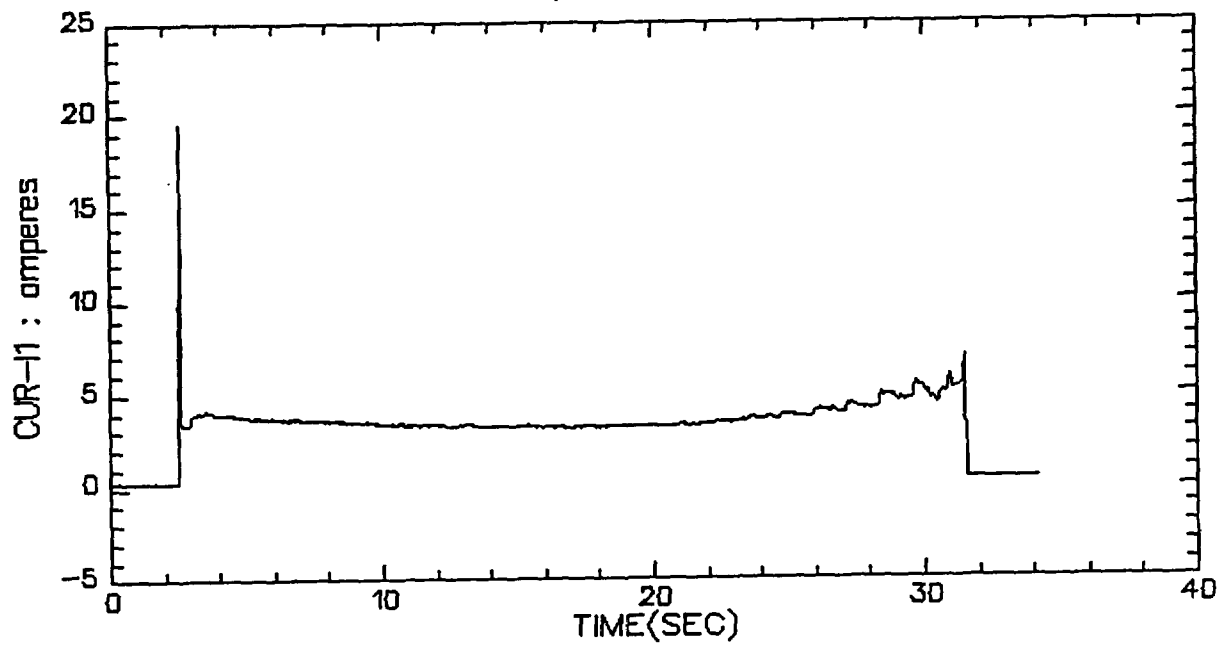

VALVE B, TEST 2, STEP 5

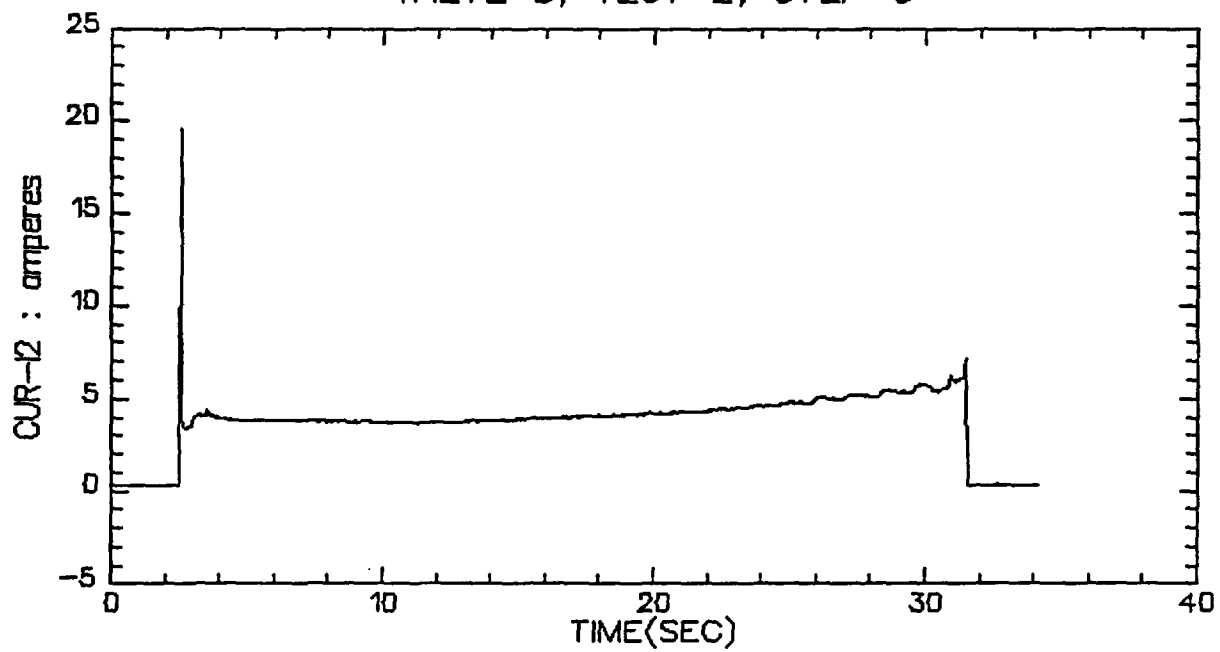

VALVE B, TEST 2, STEP 5

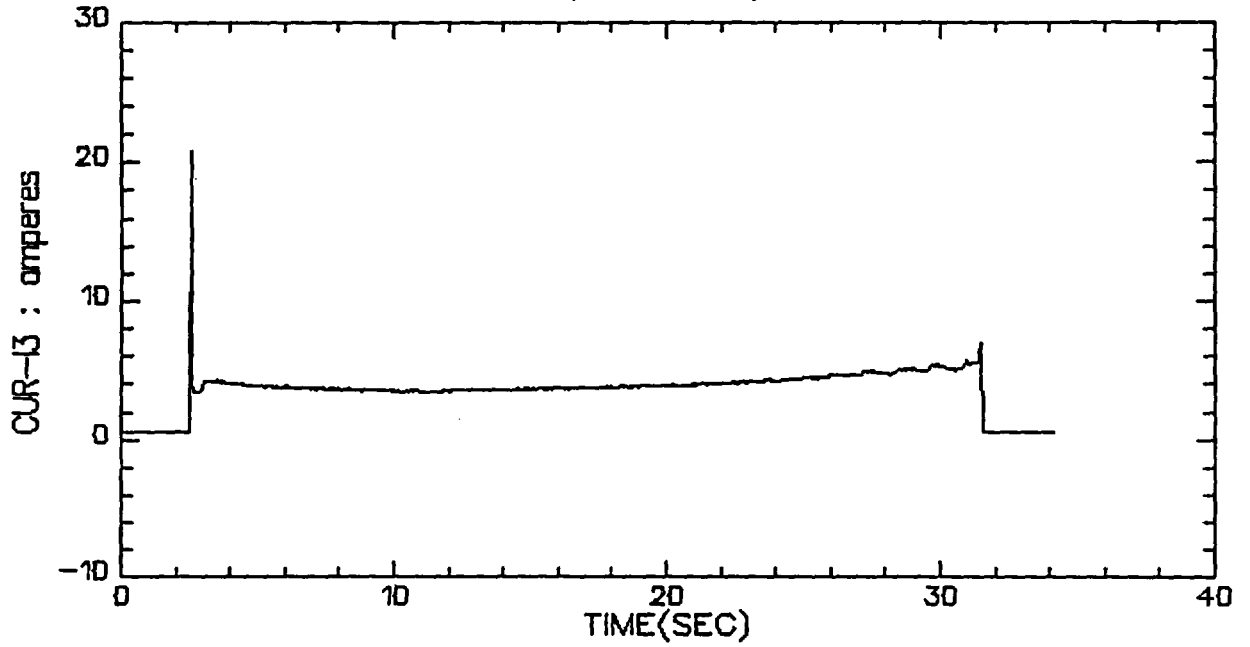

VALVE B, TEST 2, STEP 5

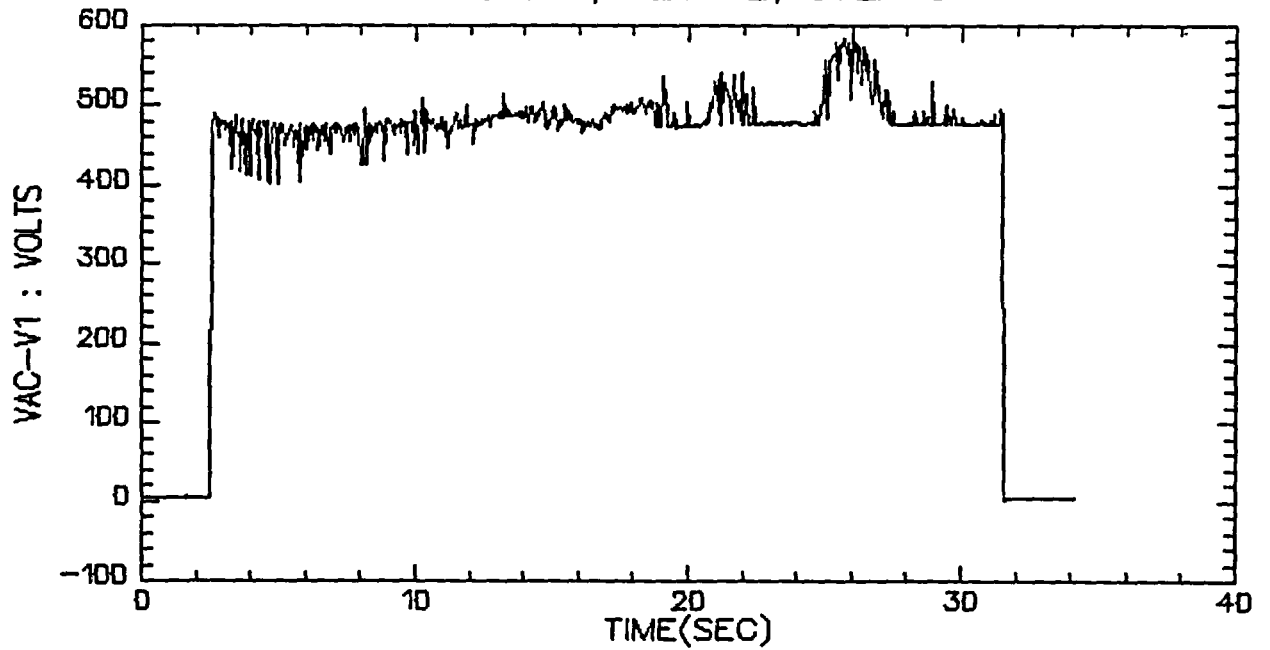

VALVE B, TEST 2, STEP 5

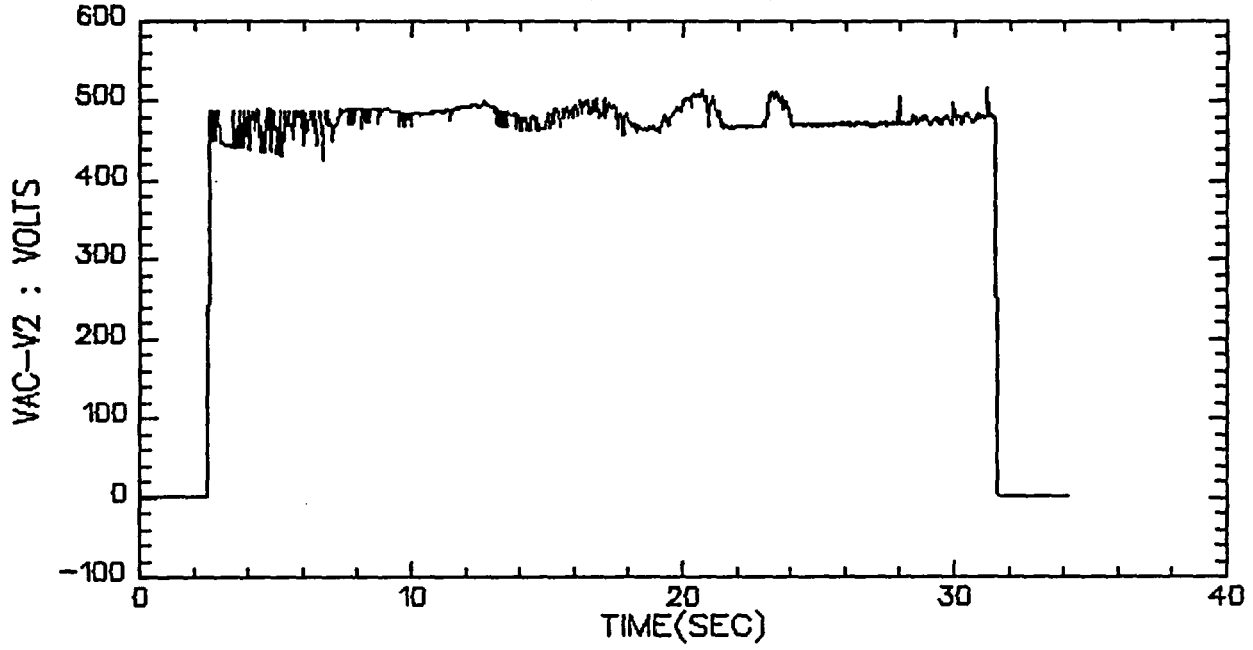

VALVE B, TEST 2, STEP 5

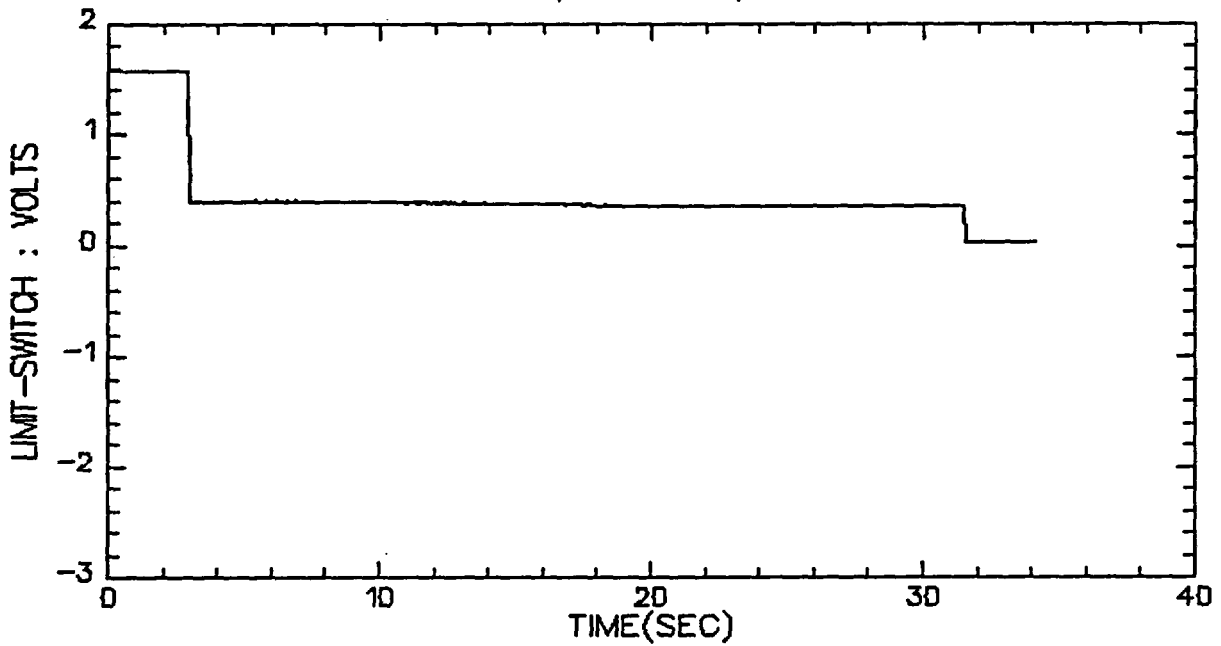

VALVE B, TEST 2, STEP 5

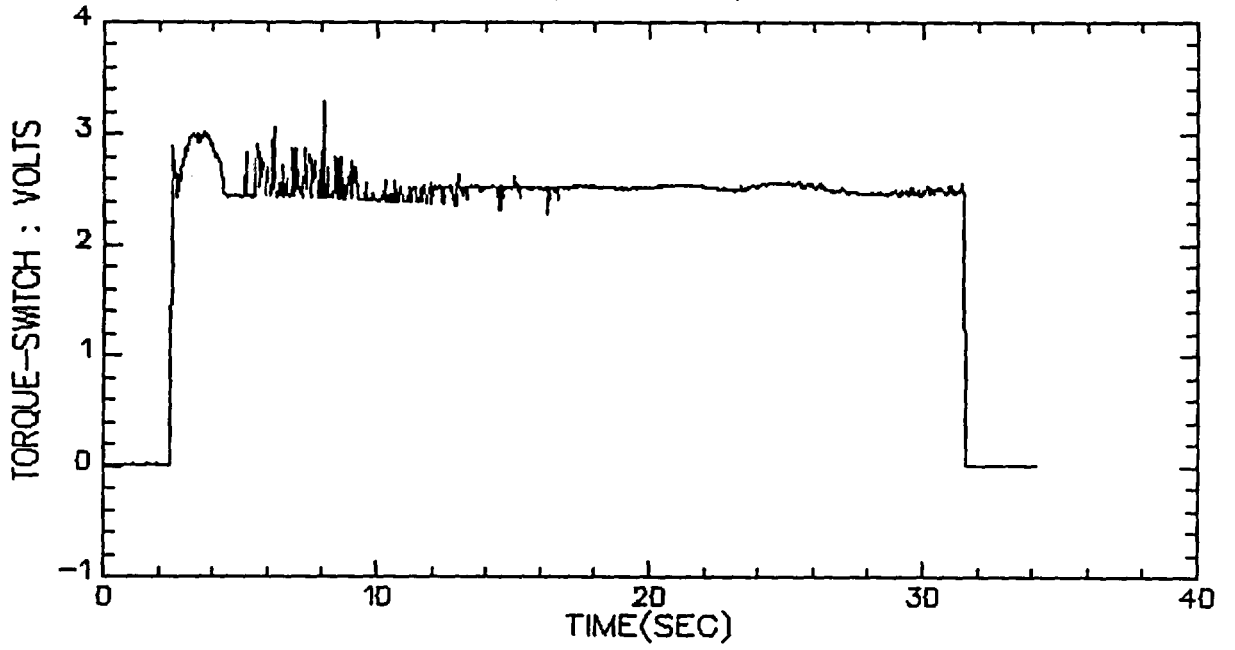

VALVE B, TEST 2, STEP 5

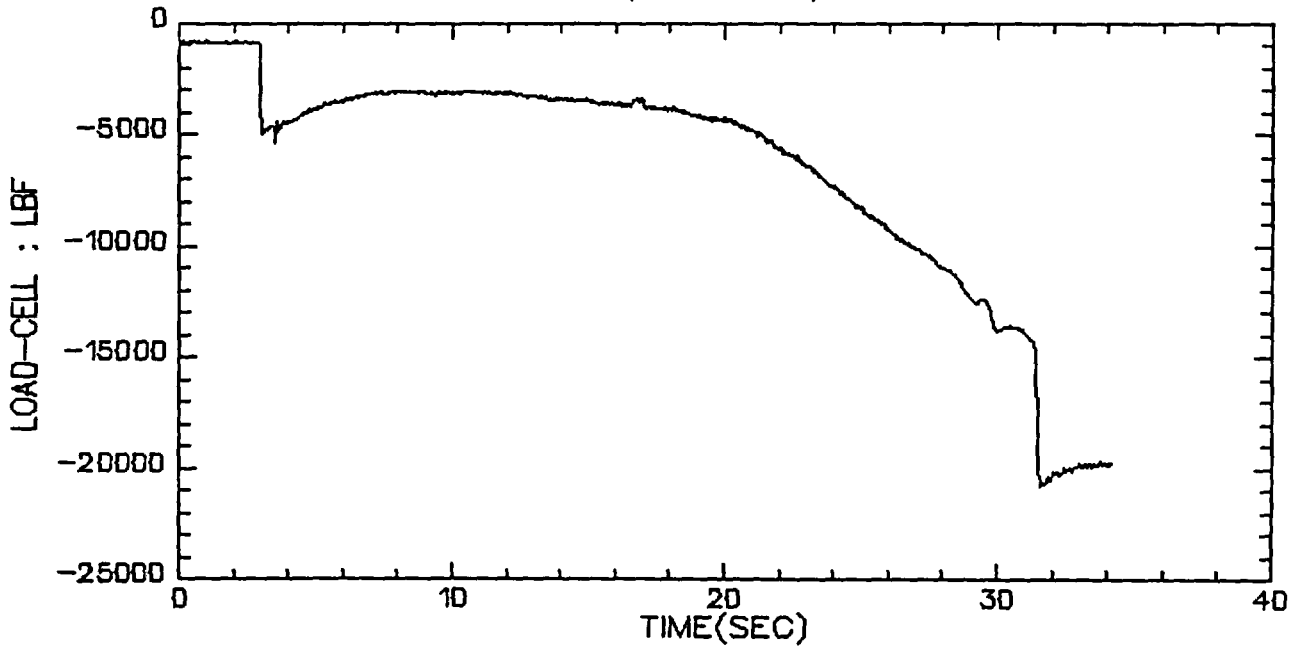

VALVE B, TEST 2, STEP 6&7

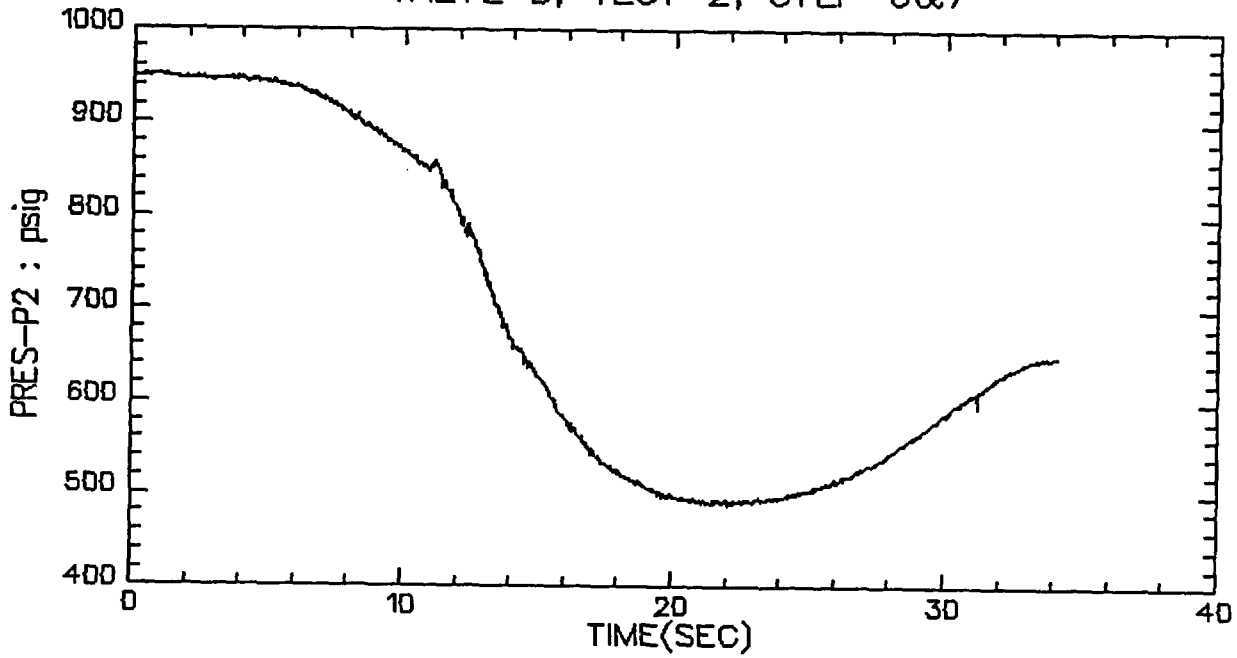

VALVE B, TEST 2, STEP 6&7

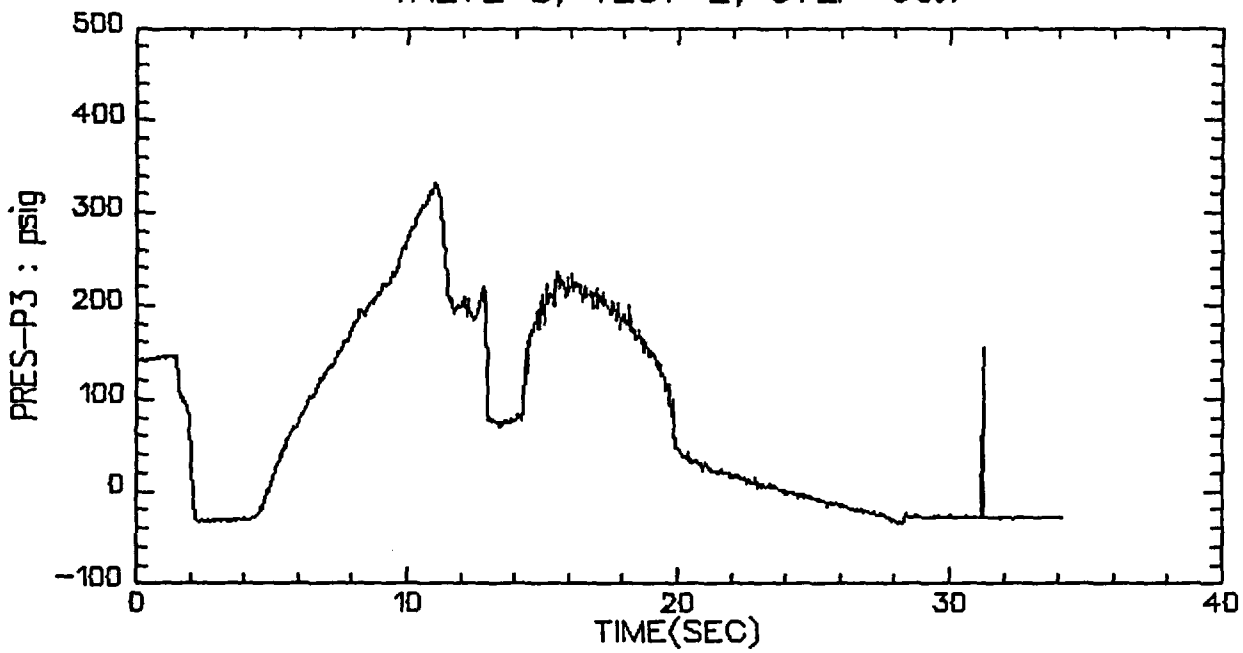

VALVE B, TEST 2, STEP 6&7

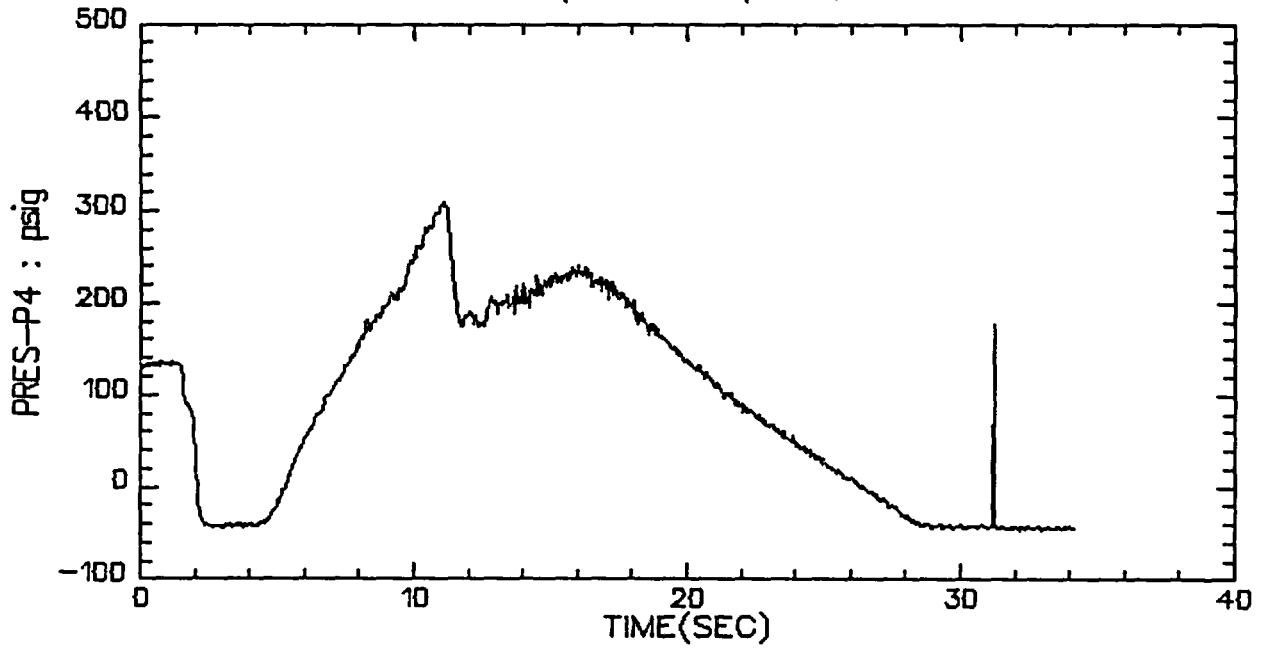

VALVE B, TEST 2, STEP 6&7

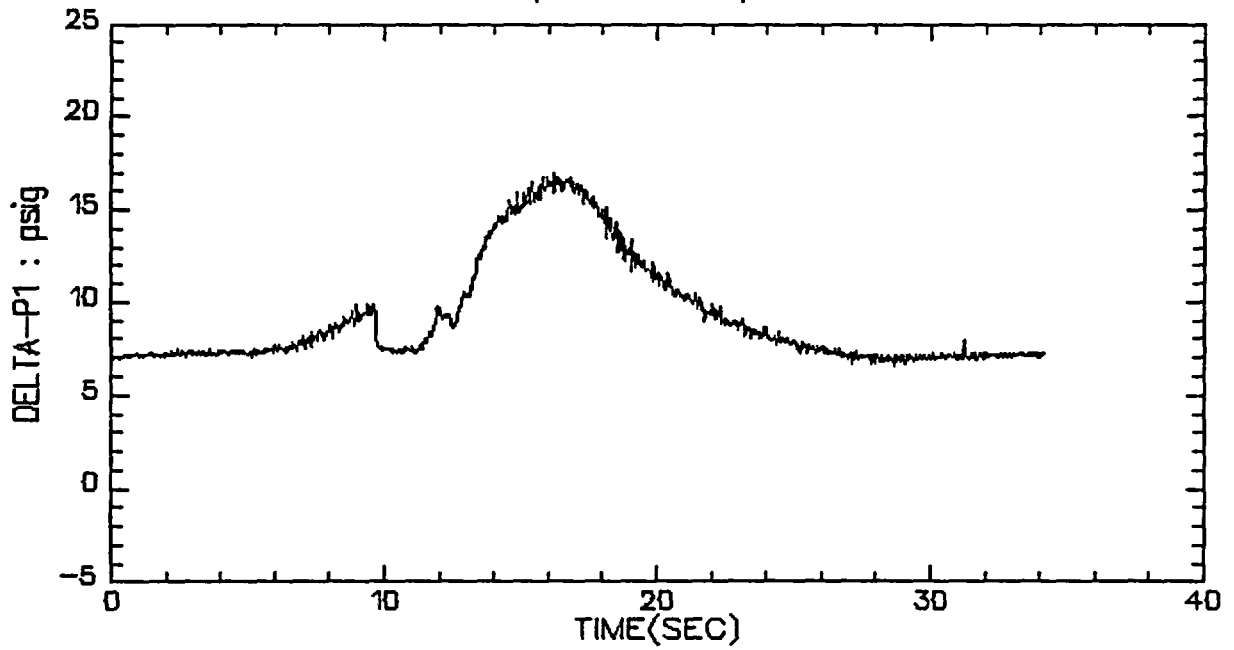

VALVE B, TEST 2, STEP 6&7

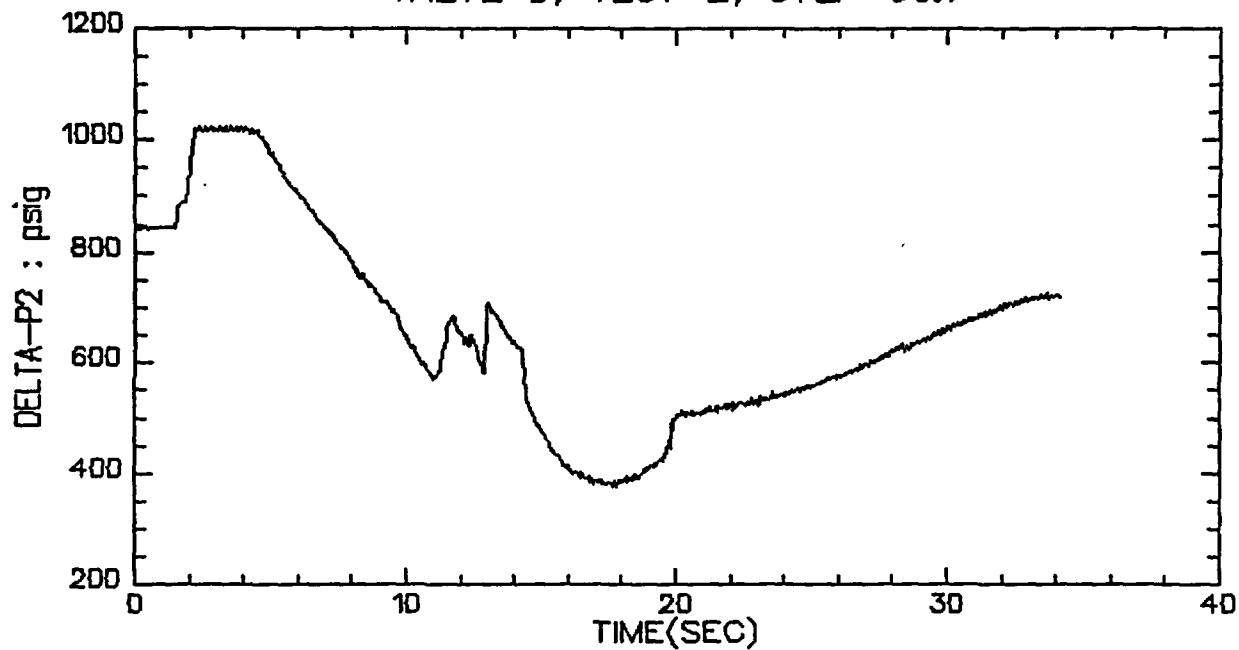

VALVE B, TEST 2, STEP 6&7

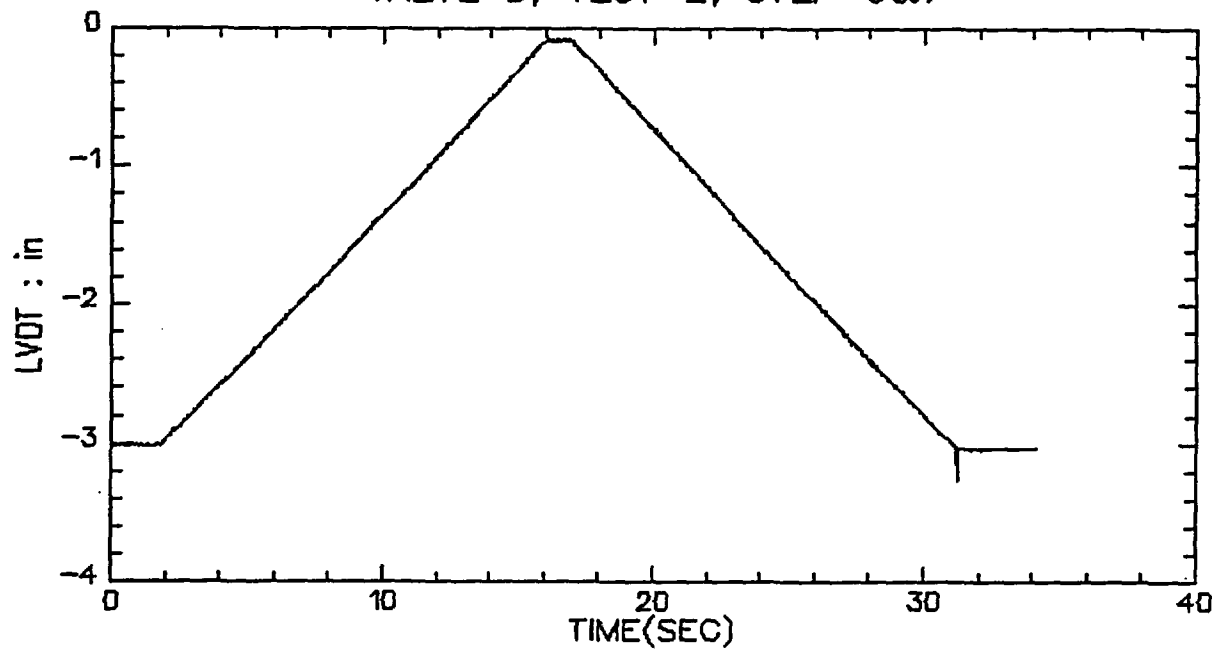

VALVE B, TEST 2, STEP 6&7

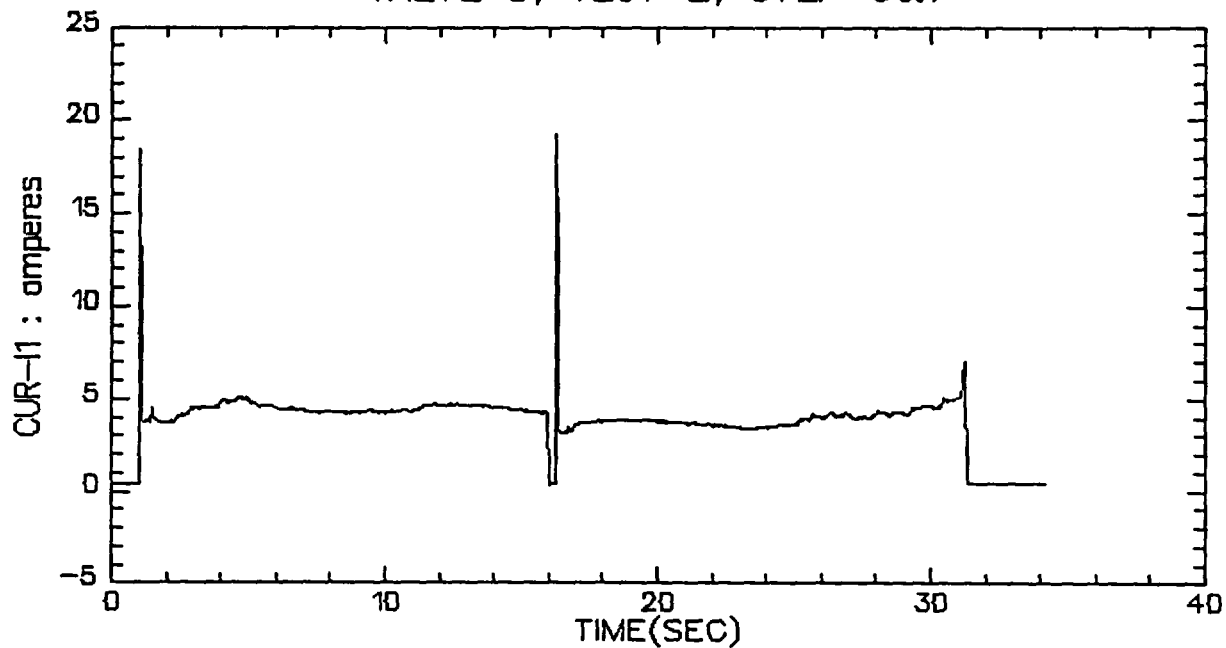

VALVE B, TEST 2, STEP 6&7

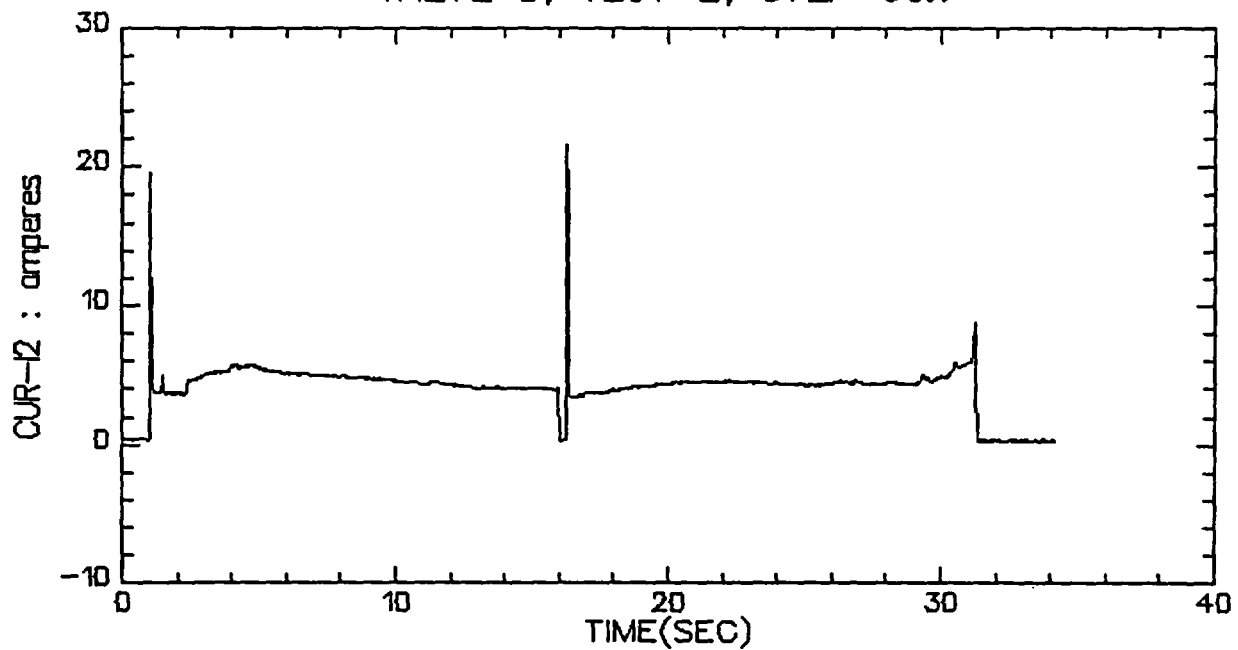

VALVE B, TEST 2, STEP 6&7

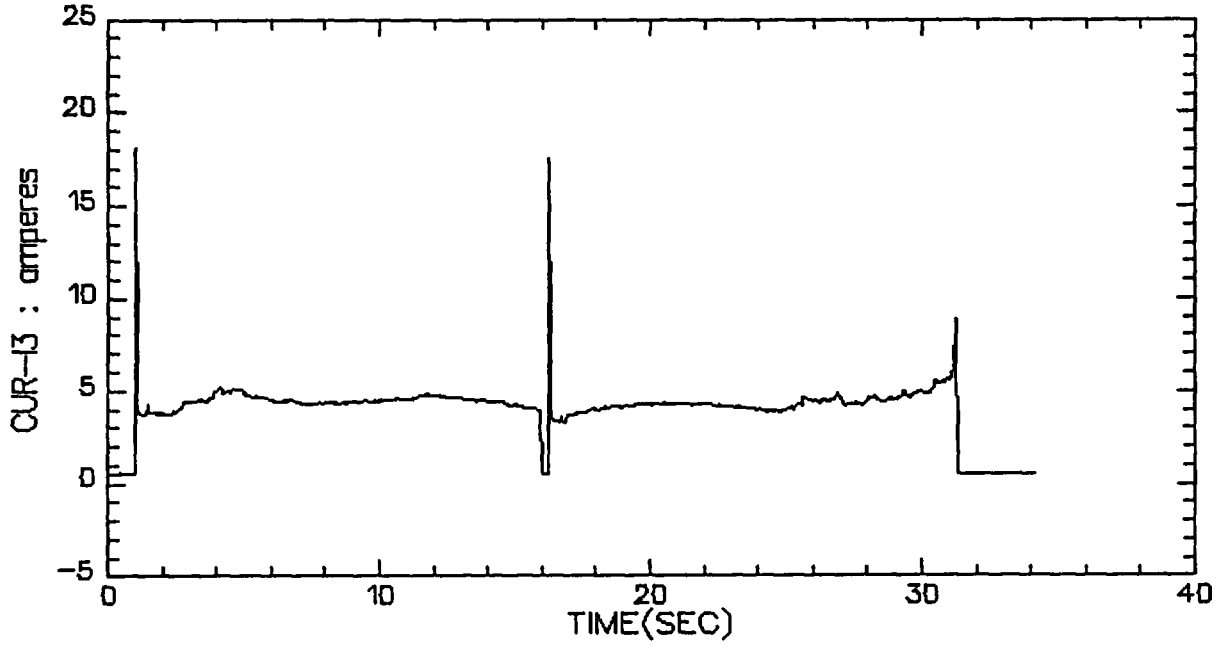

VALVE B, TEST 2, STEP 6&7

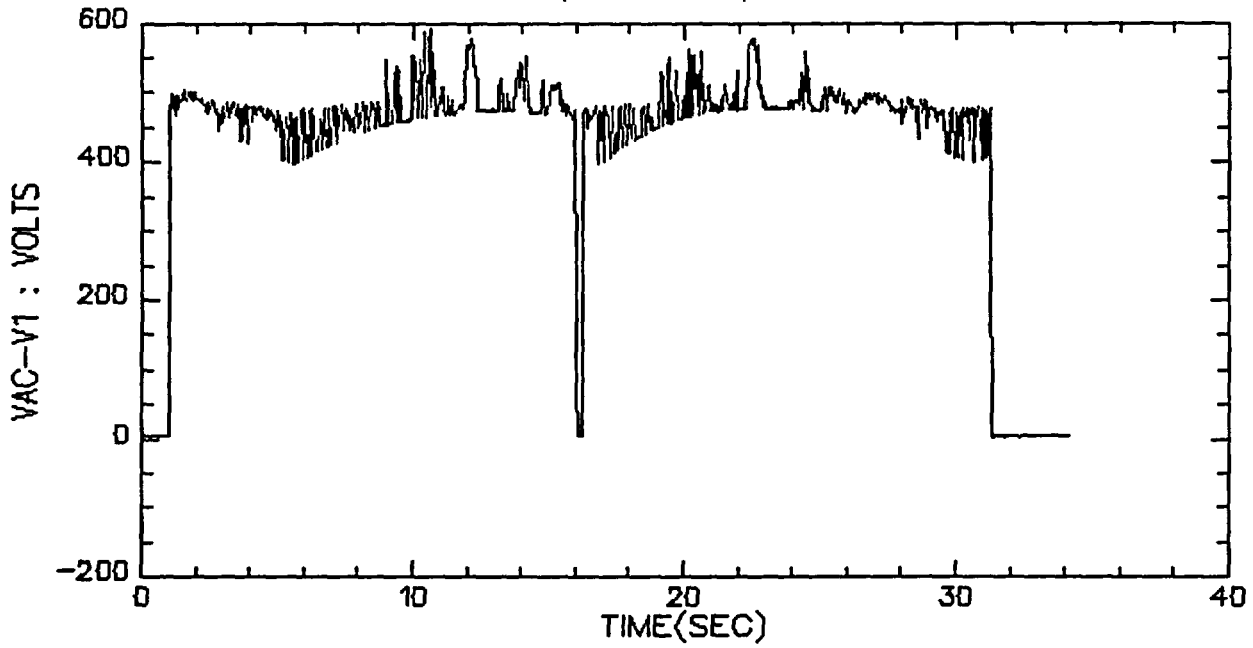

VALVE B, TEST 2, STEP 6&7

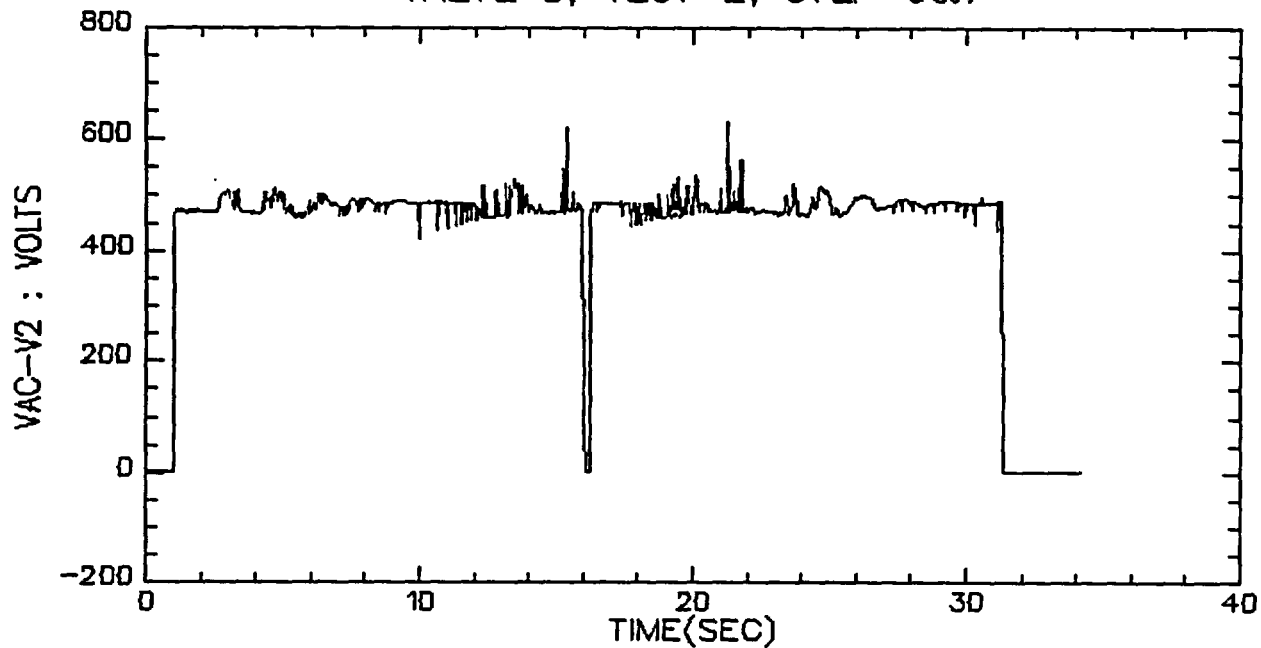

VALVE B, TEST 2, STEP 6&7

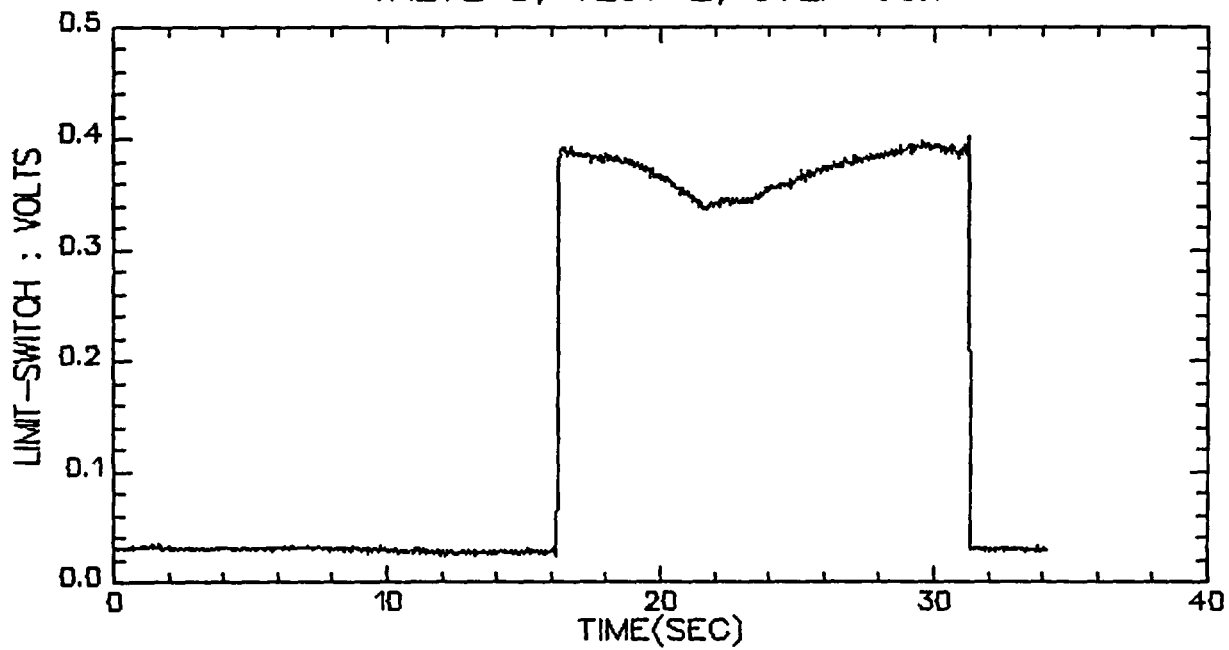

VALVE B, TEST 2, STEP 6&7

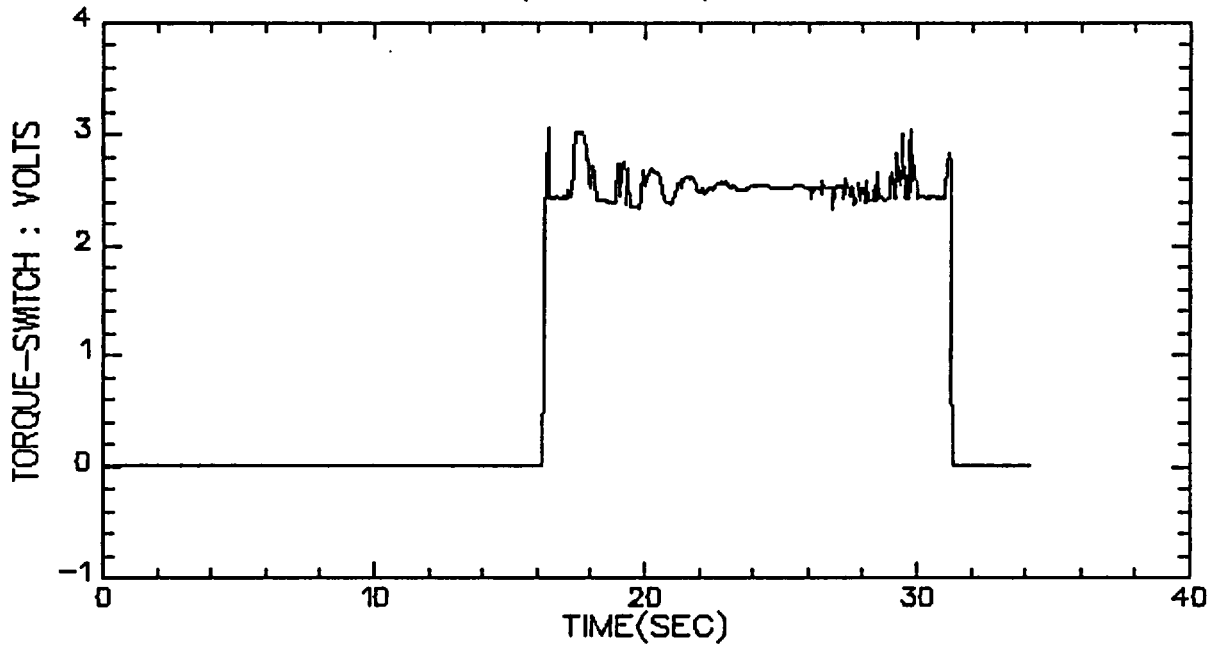

VALVE B, TEST 2, STEP 6&7

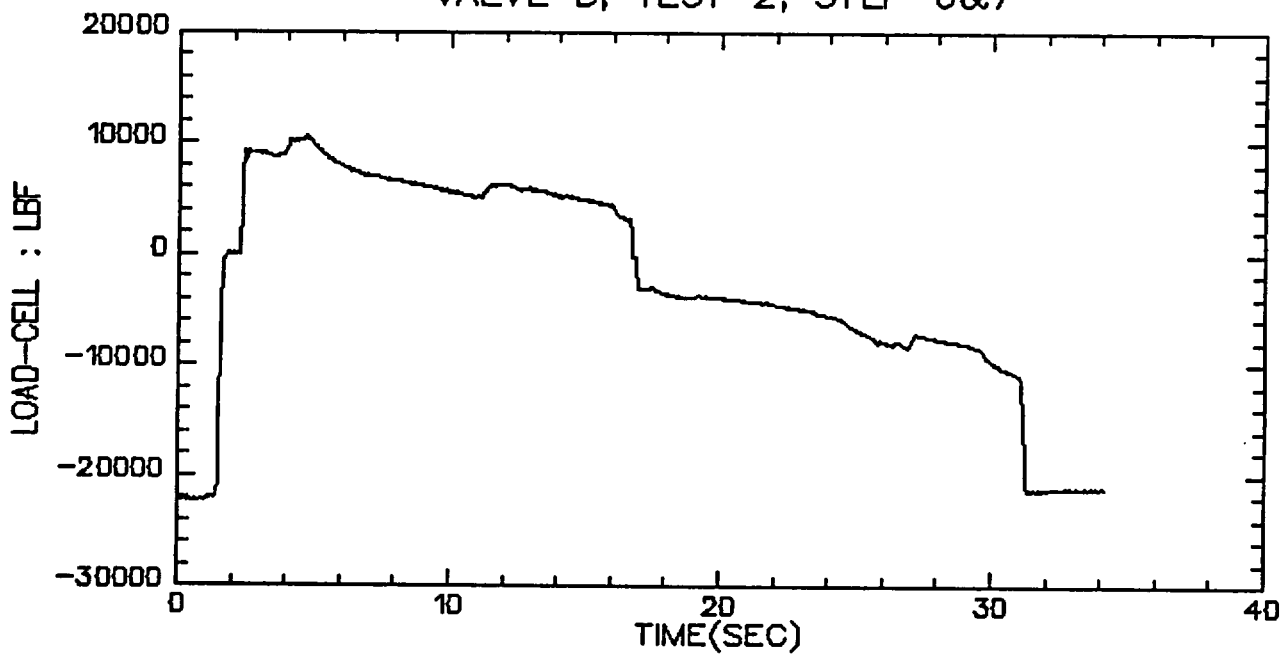

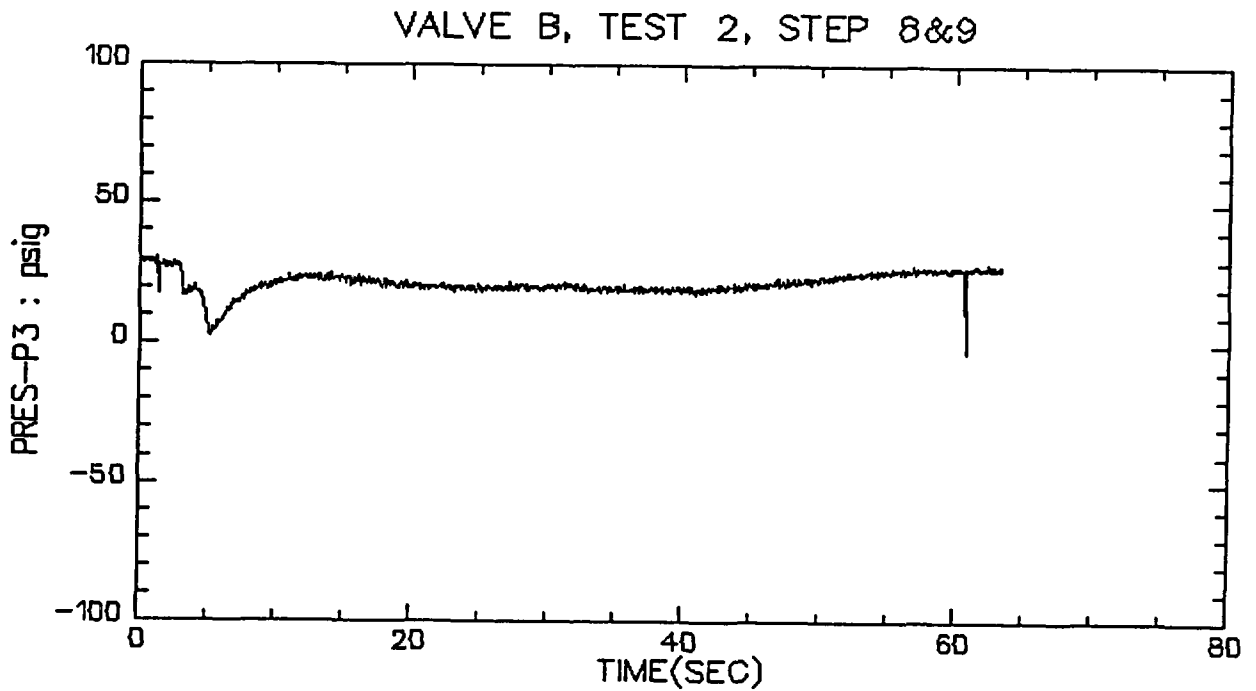
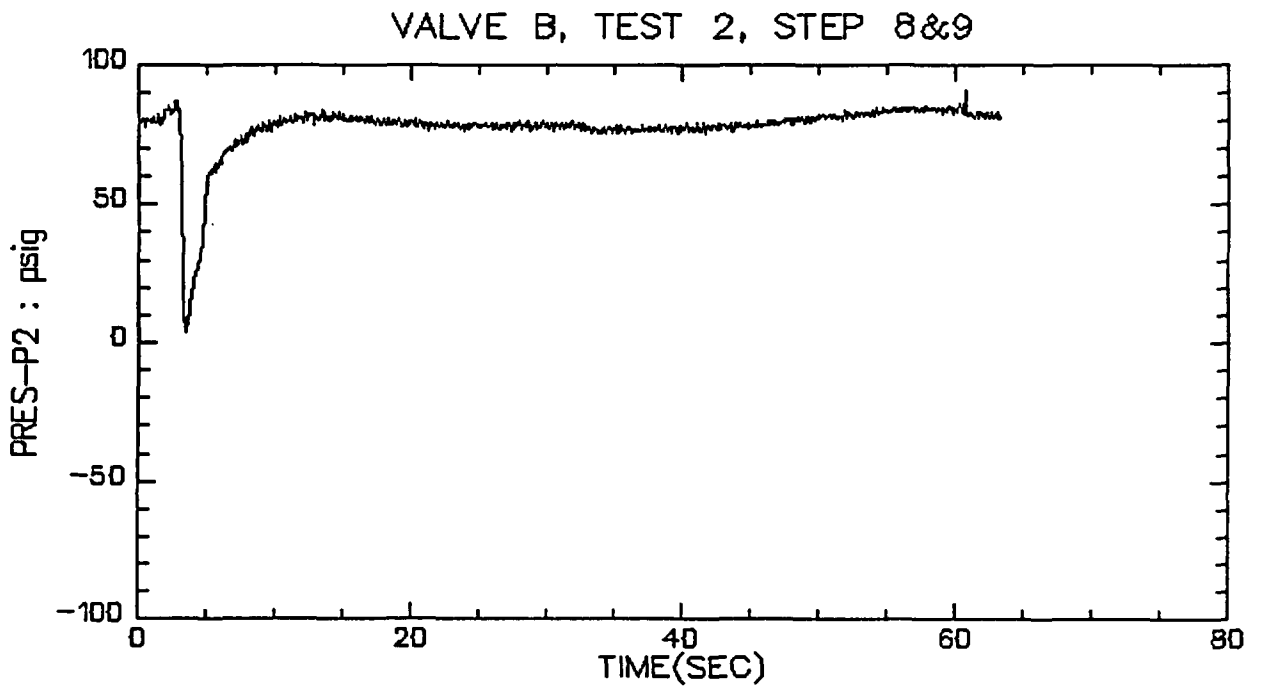

VALVE B, TEST 2, STEP 8&9

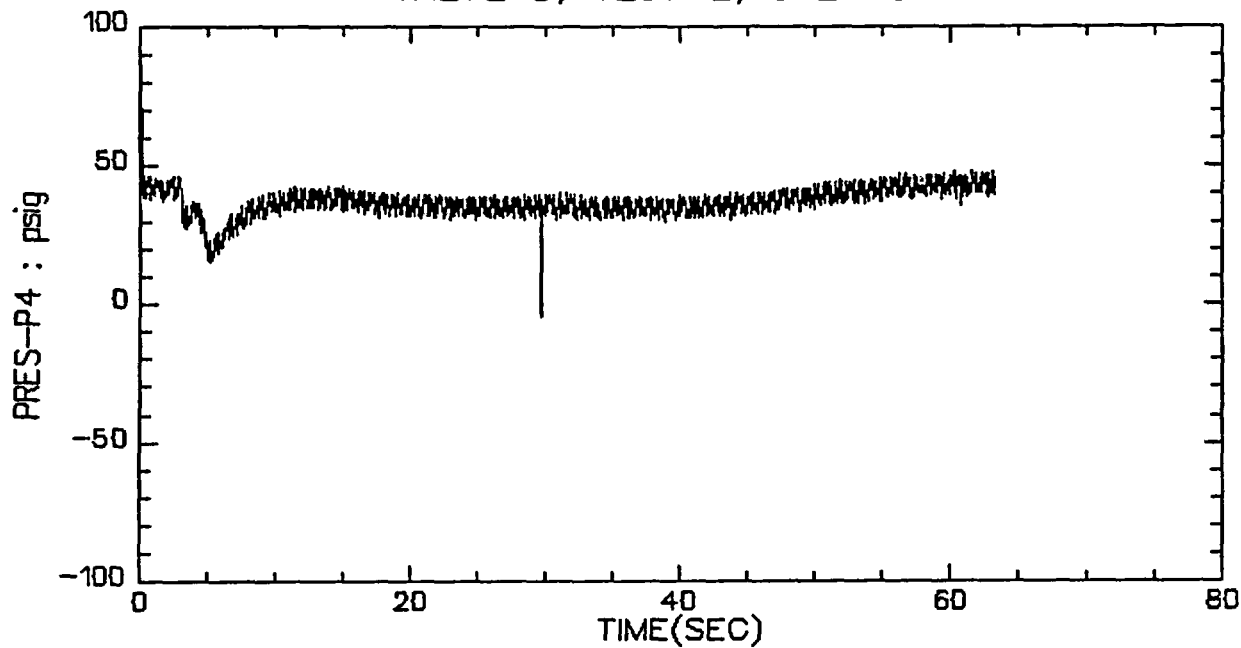

VALVE B, TEST 2, STEP 8&9

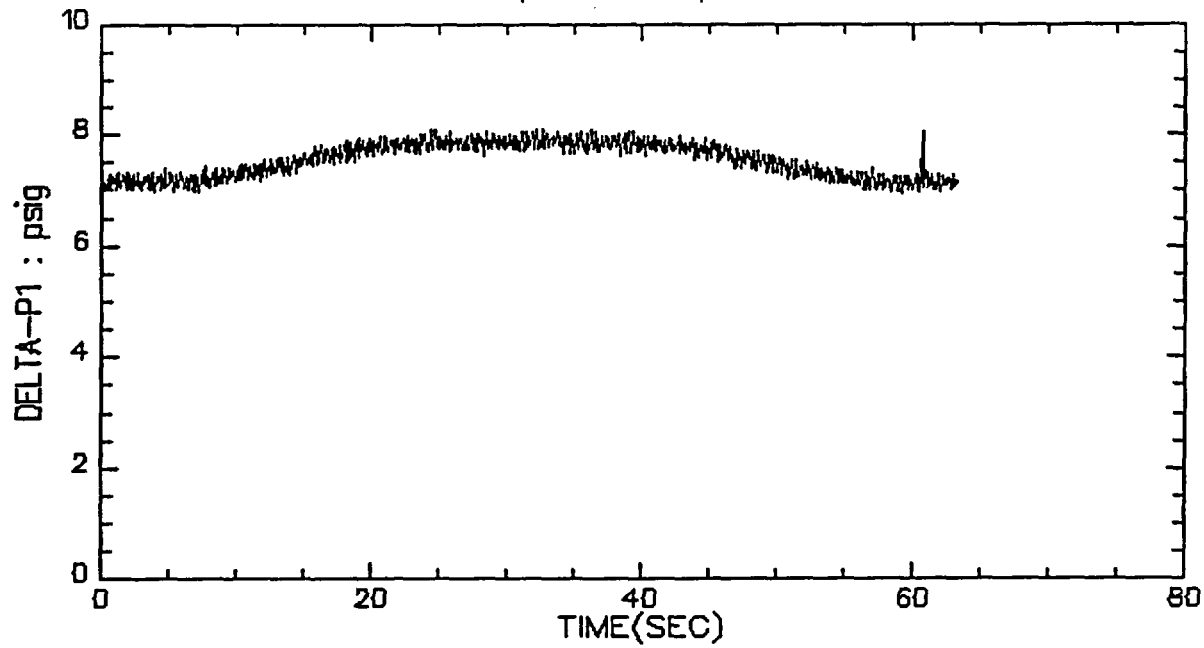

VALVE B, TEST 2, STEP 8&9

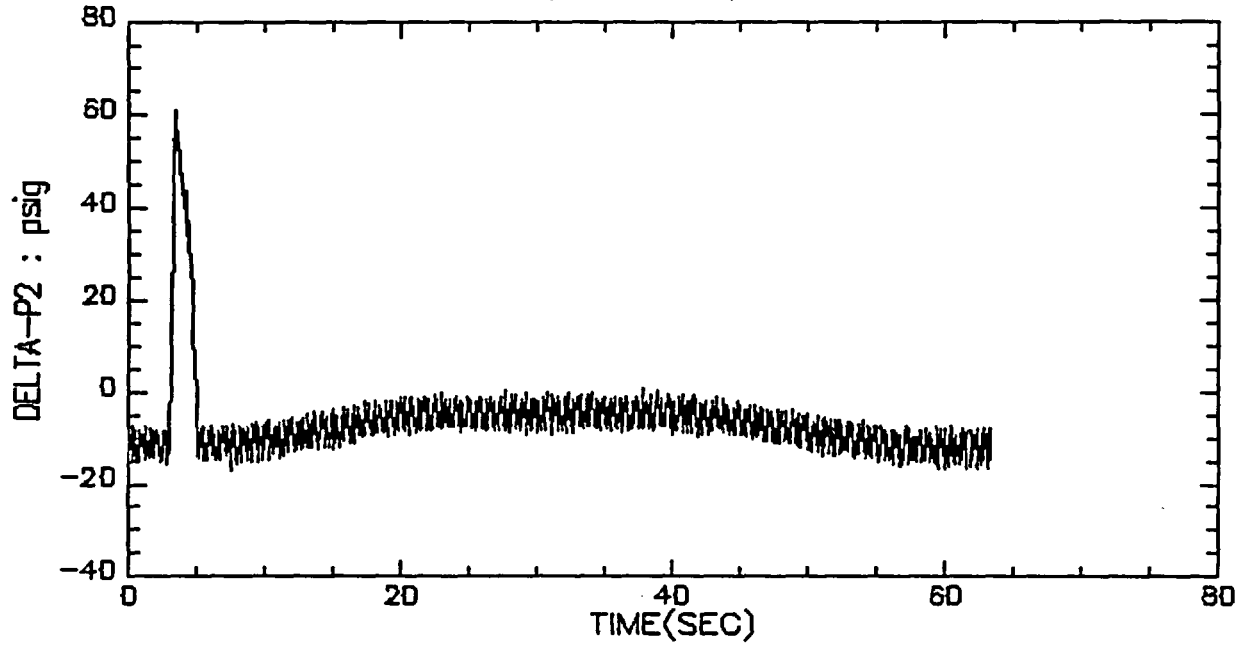

VALVE B, TEST 2, STEP 8&9

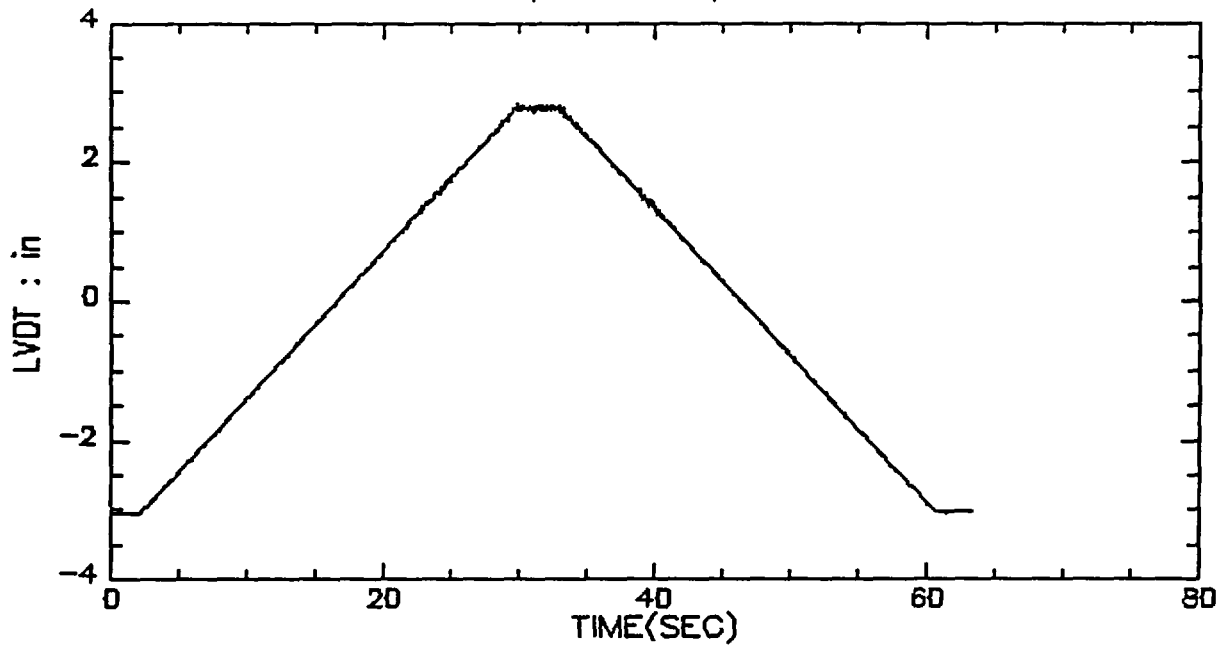

VALVE B, TEST 2, STEP 8&9

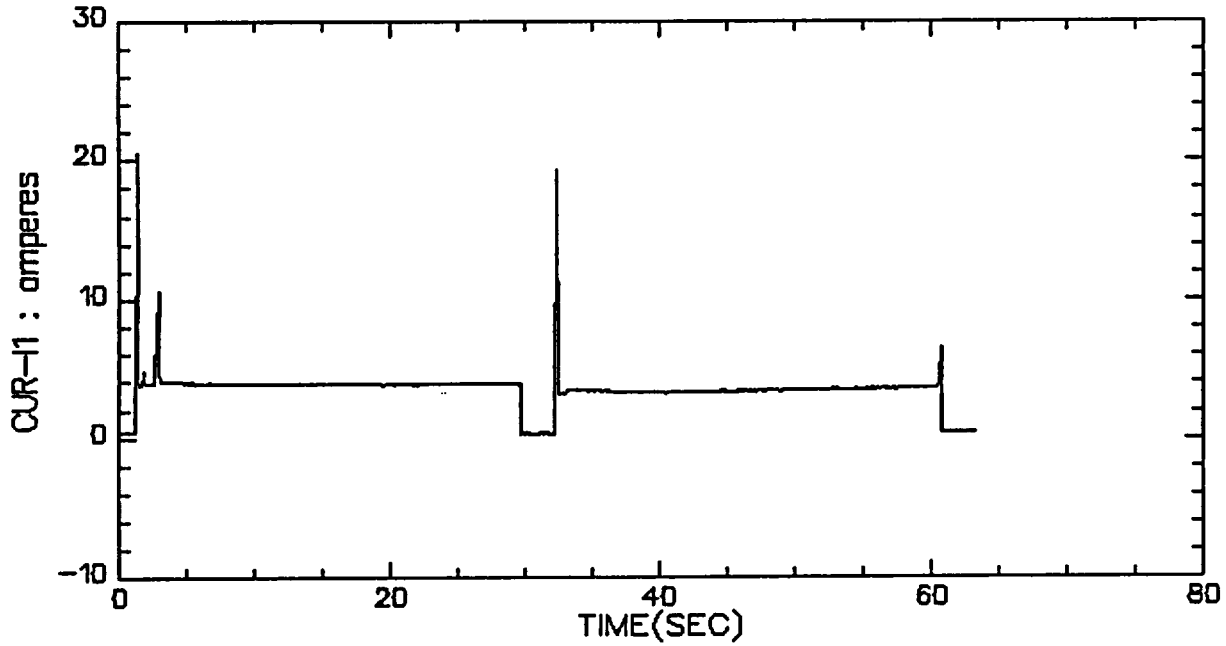

VALVE B, TEST 2, STEP 8&9

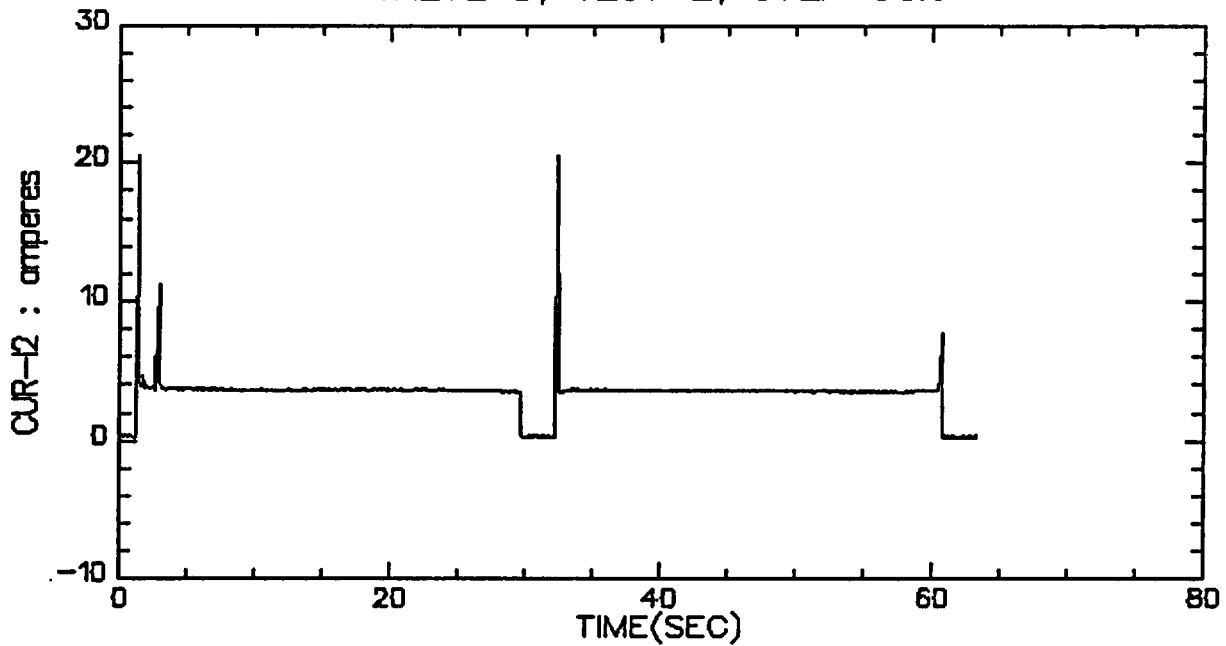

VALVE B, TEST 2, STEP 8&9

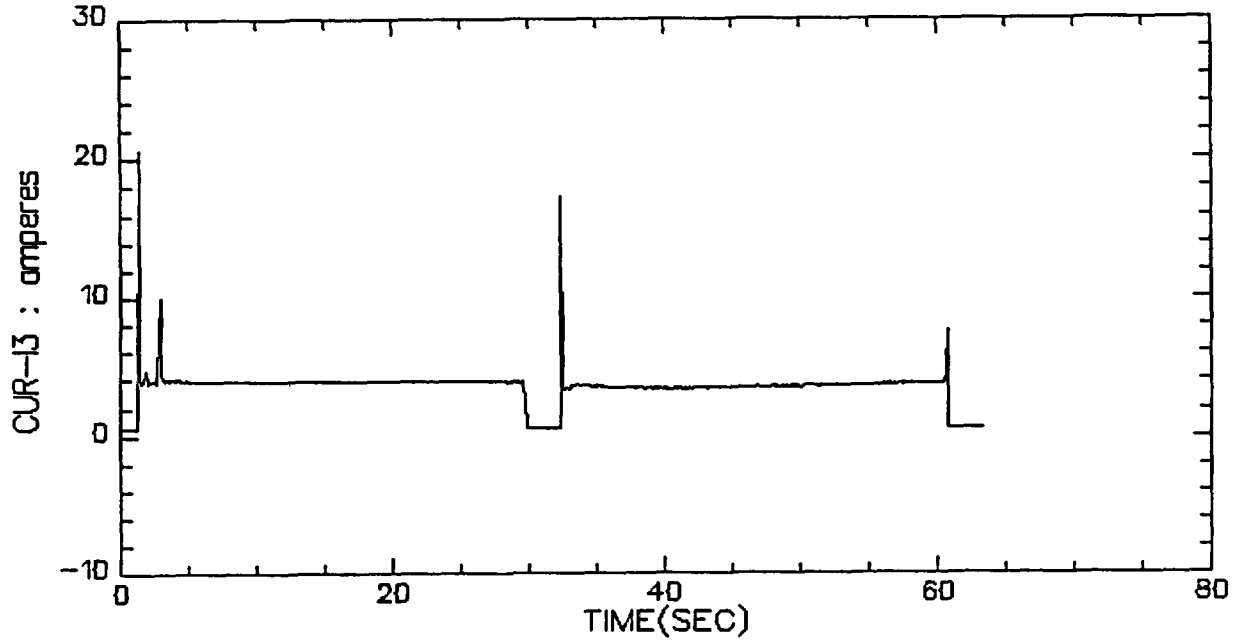

VALVE B, TEST 2, STEP 8&9

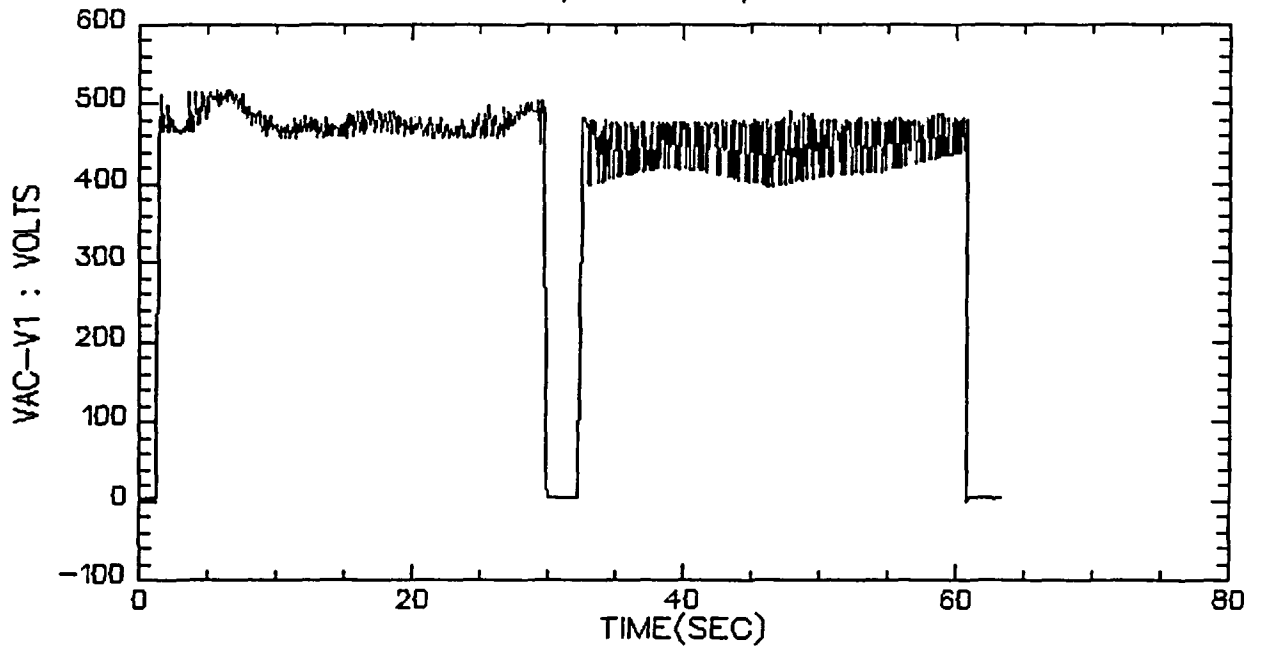

VALVE B, TEST 2, STEP 8&9

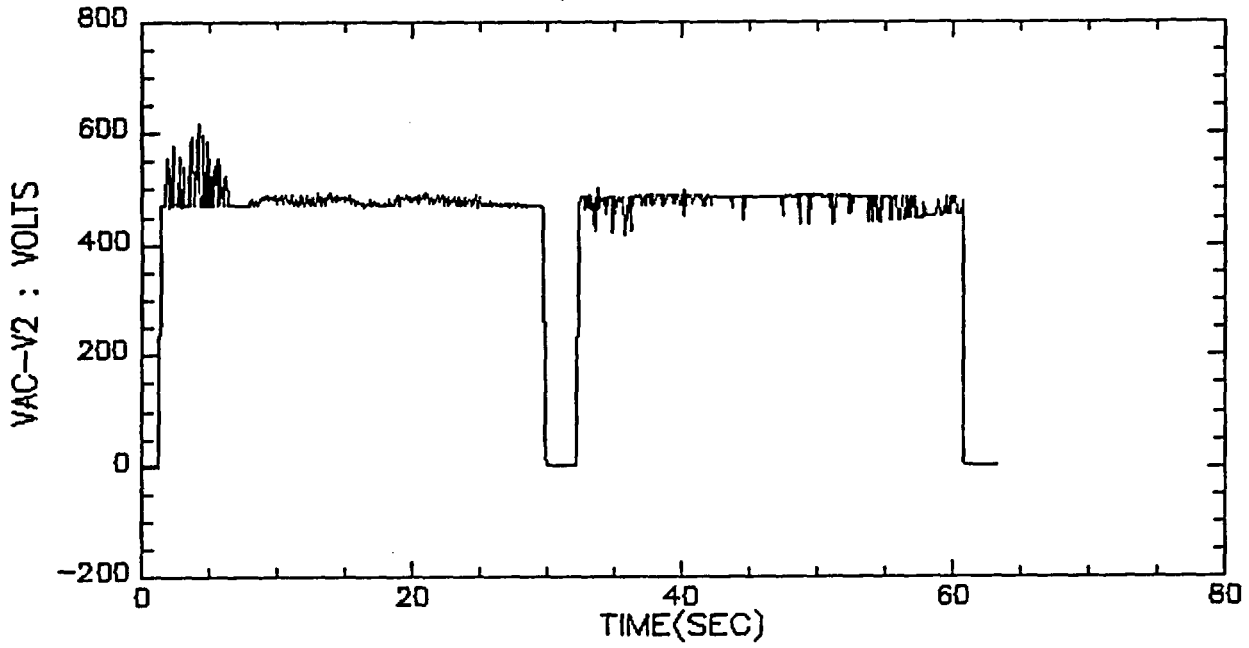

VALVE B, TEST 2, STEP 8&9

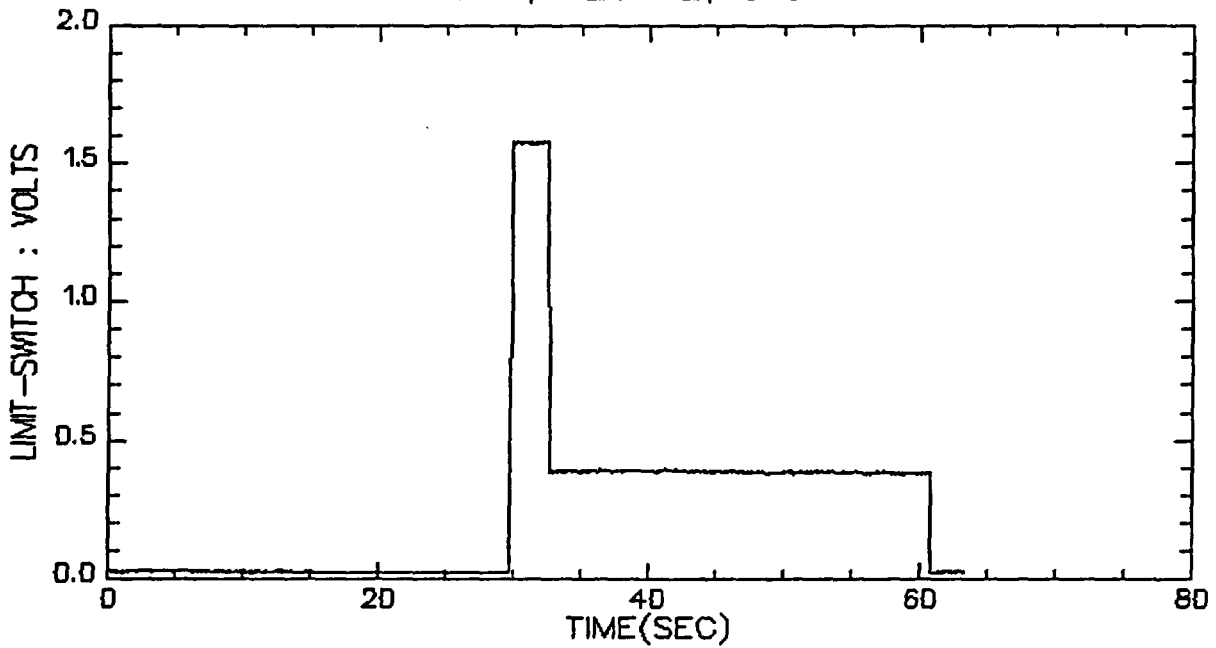

VALVE B, TEST 2, STEP 8&9

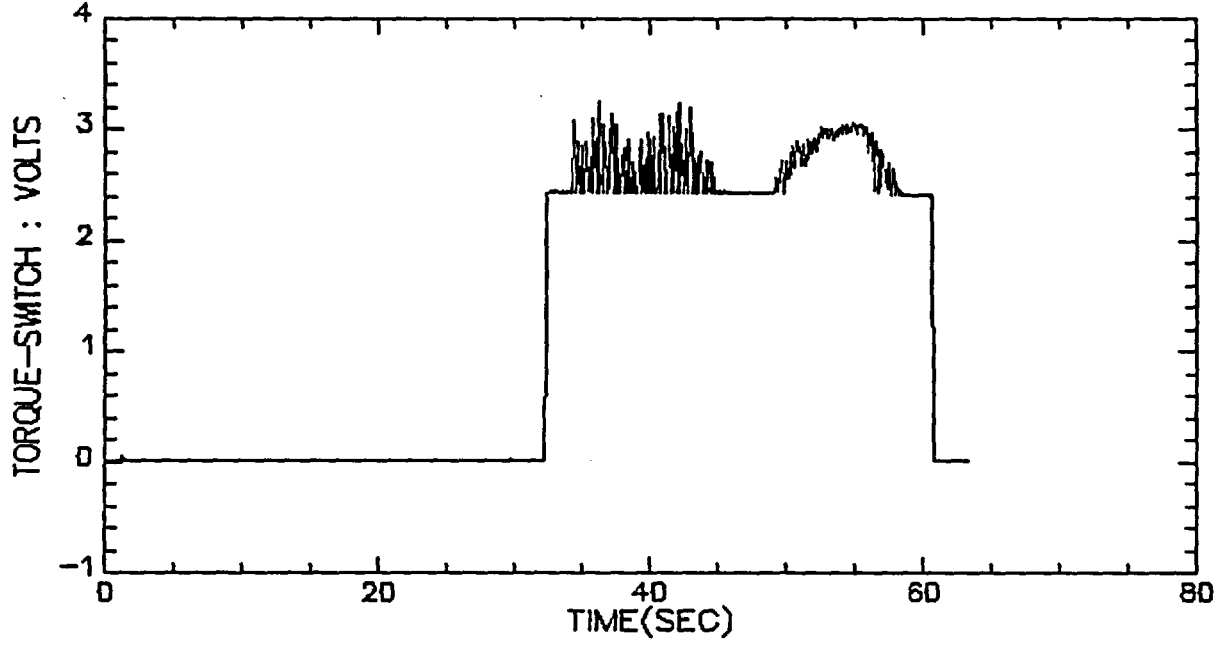

VALVE B, TEST 2, STEP 8&9

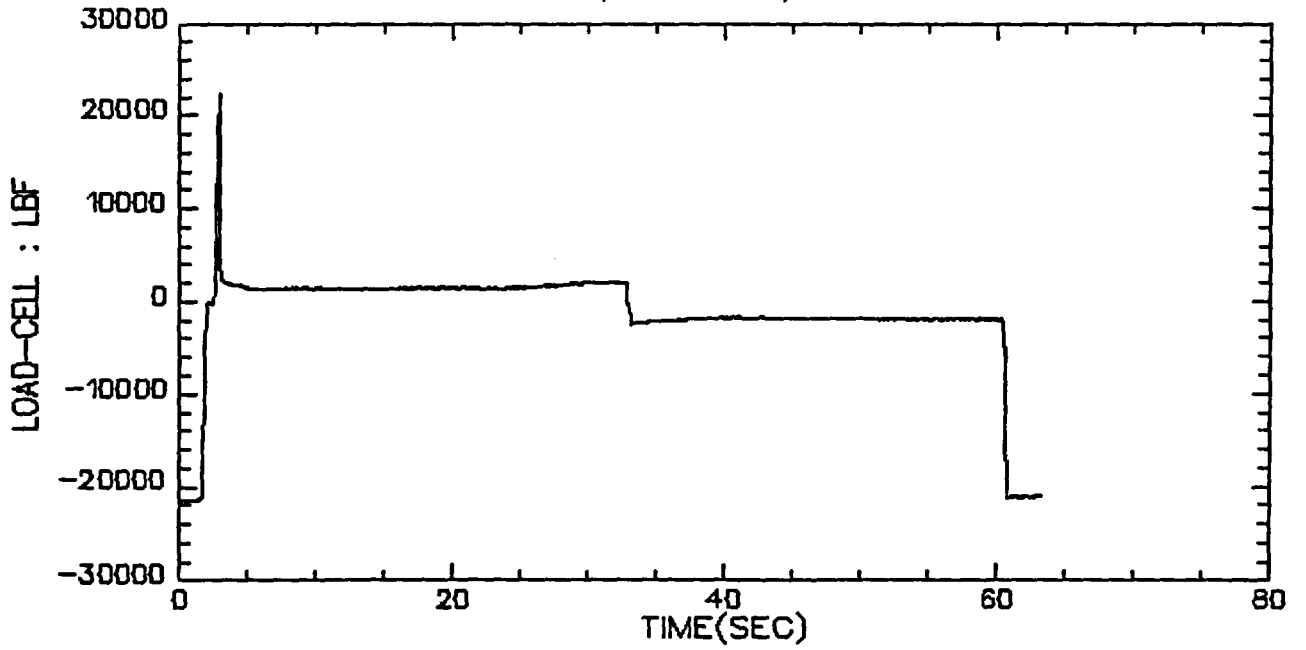

VALVE B, TEST 3, STEP 1

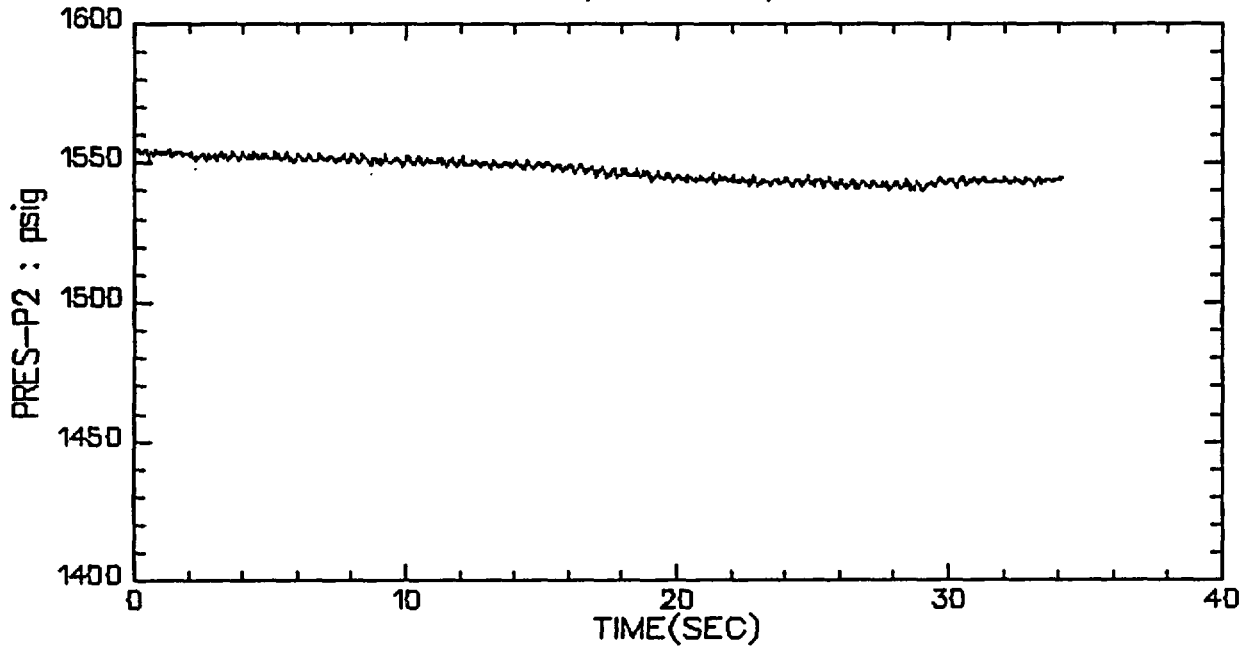

VALVE B, TEST 3, STEP 1

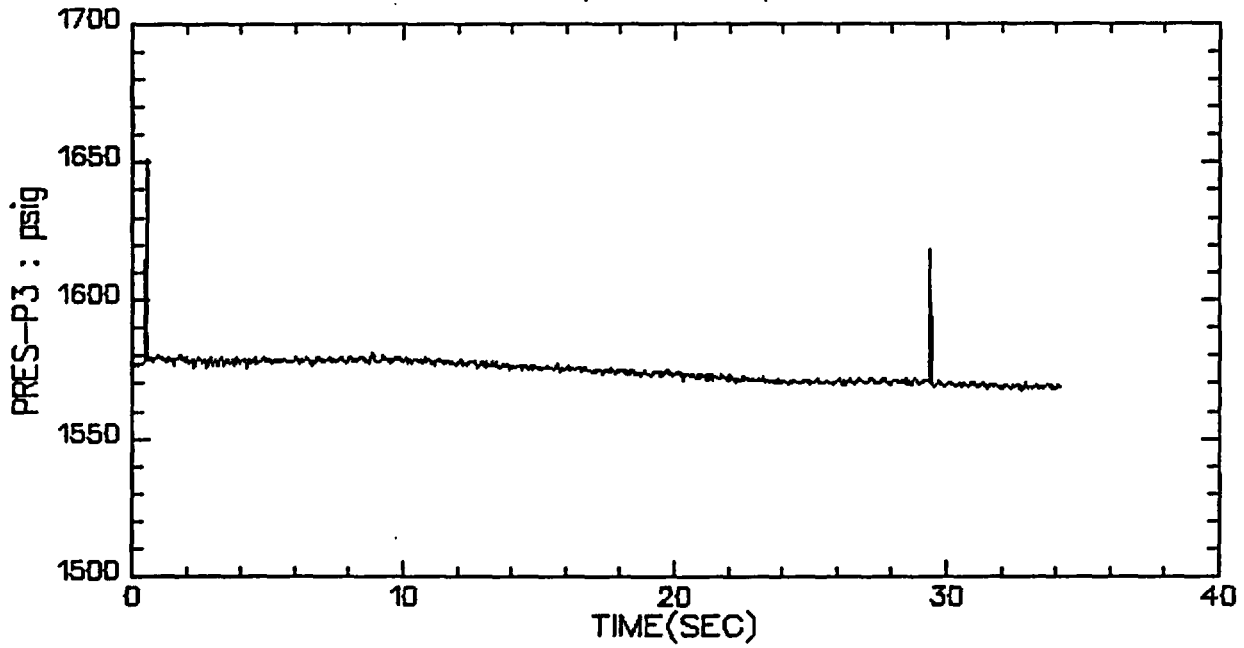

VALVE B, TEST 3, STEP 1

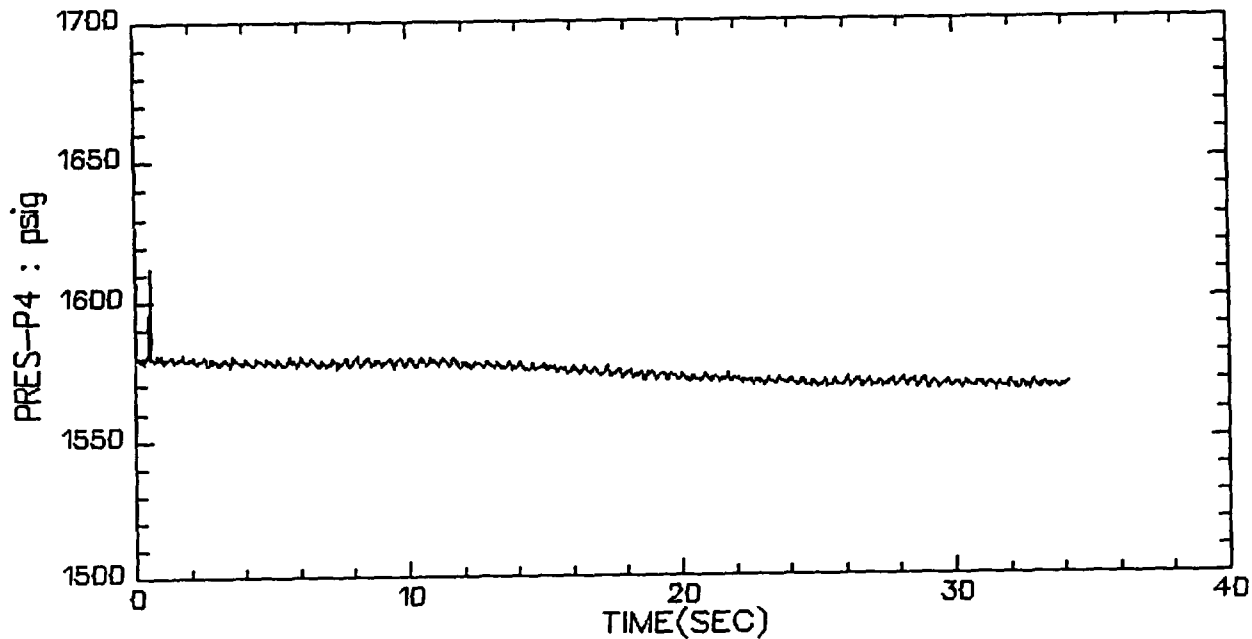

VALVE B, TEST 3, STEP 1

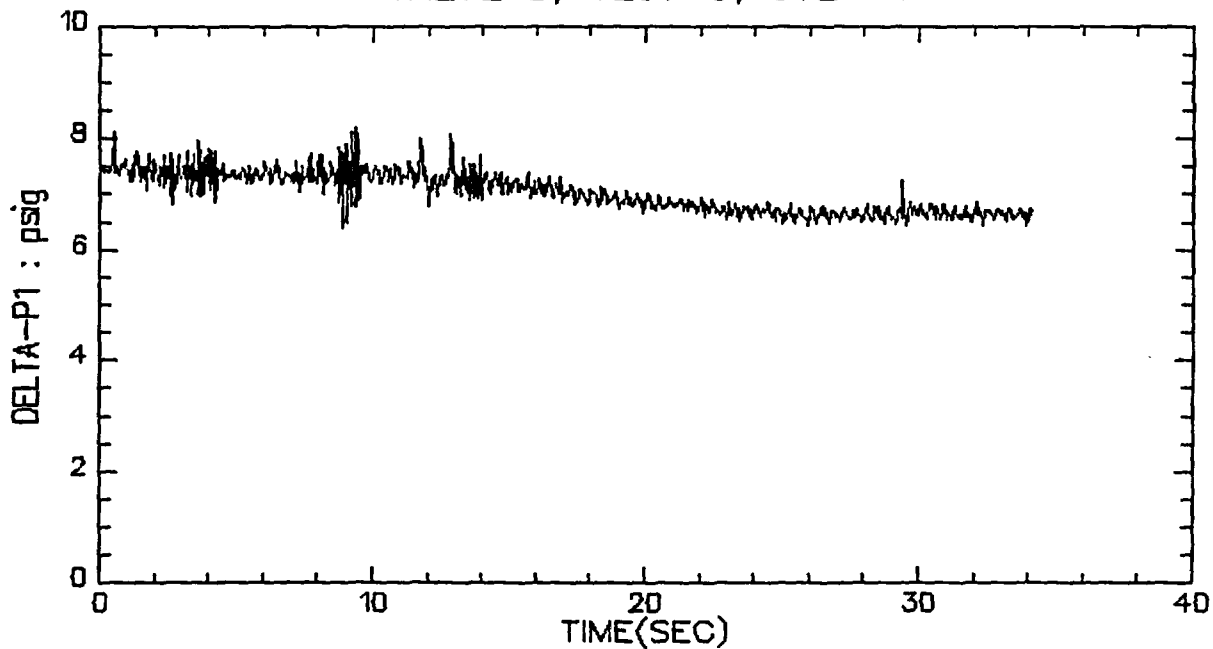

VALVE B, TEST 3, STEP 1

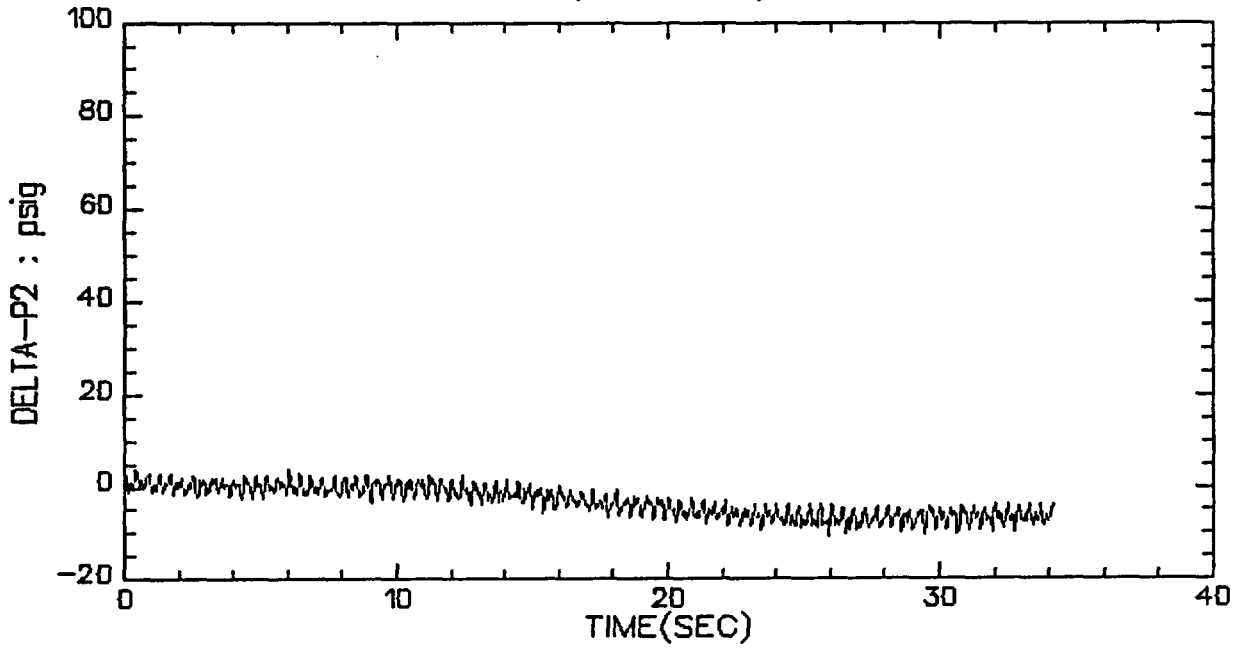

VALVE B, TEST 3, STEP 1

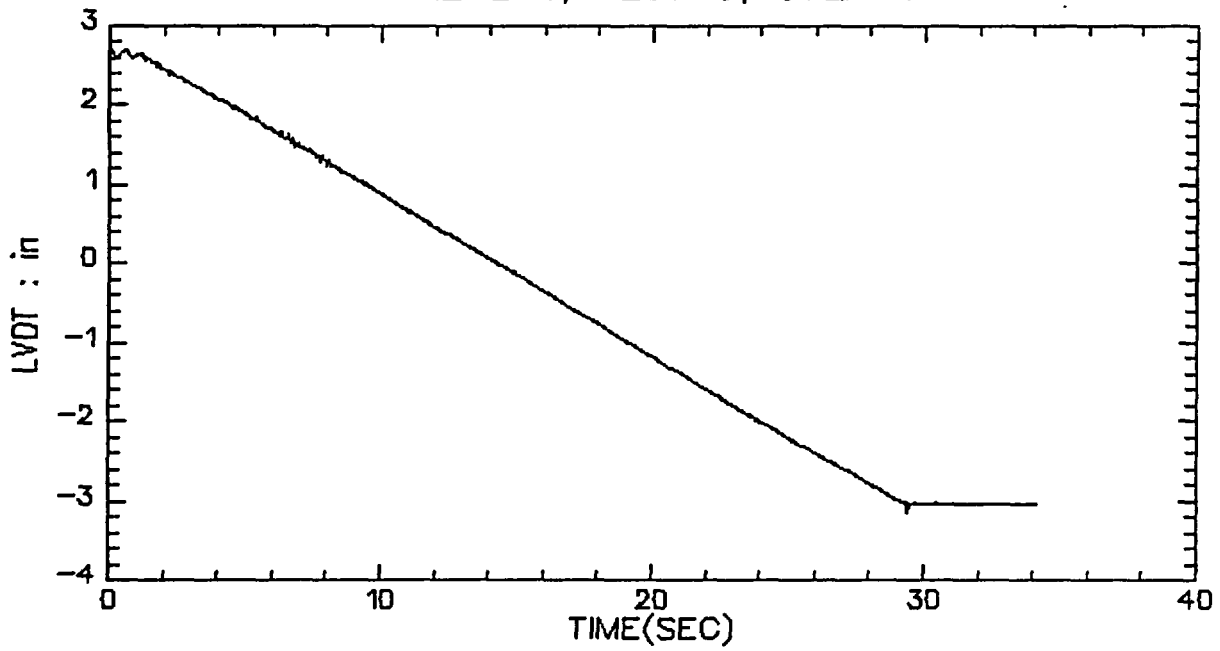

VALVE B, TEST 3, STEP 1

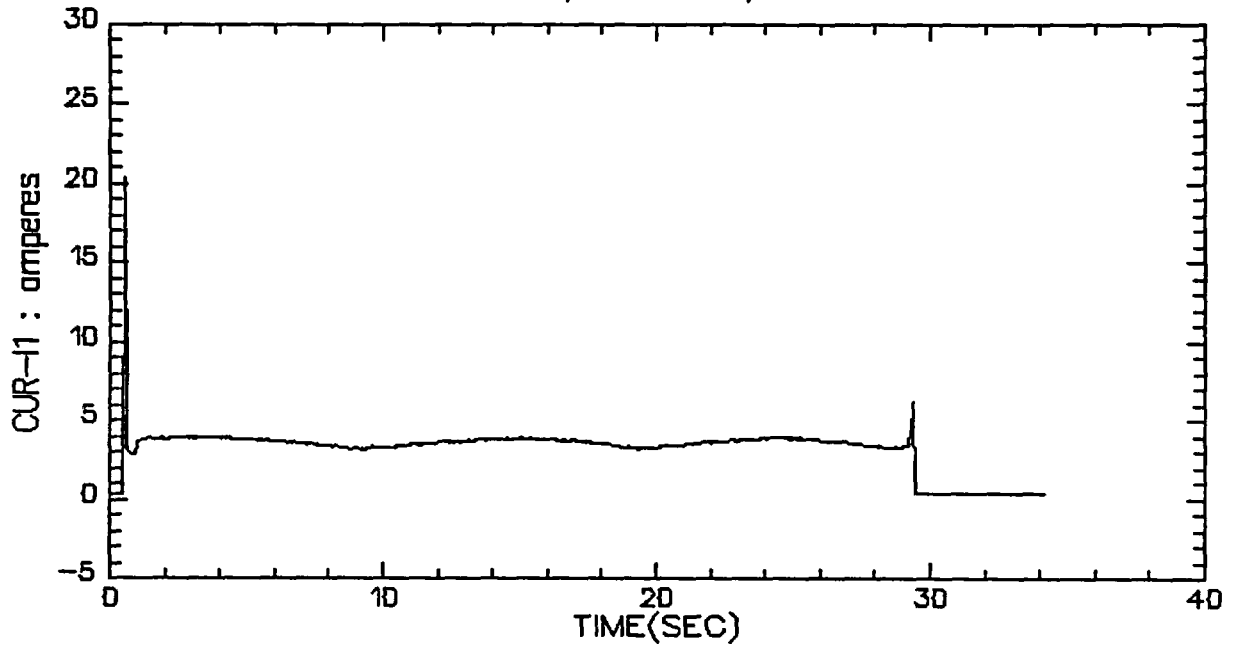

VALVE B, TEST 3, STEP 1

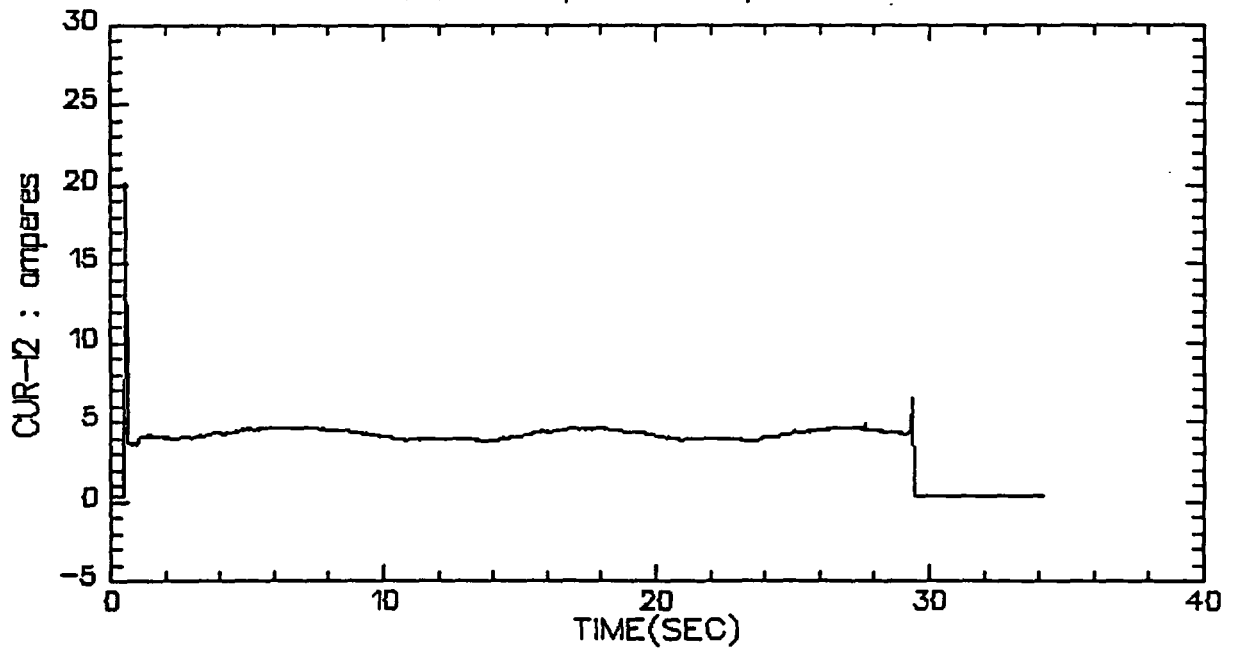

VALVE B, TEST 3, STEP 1

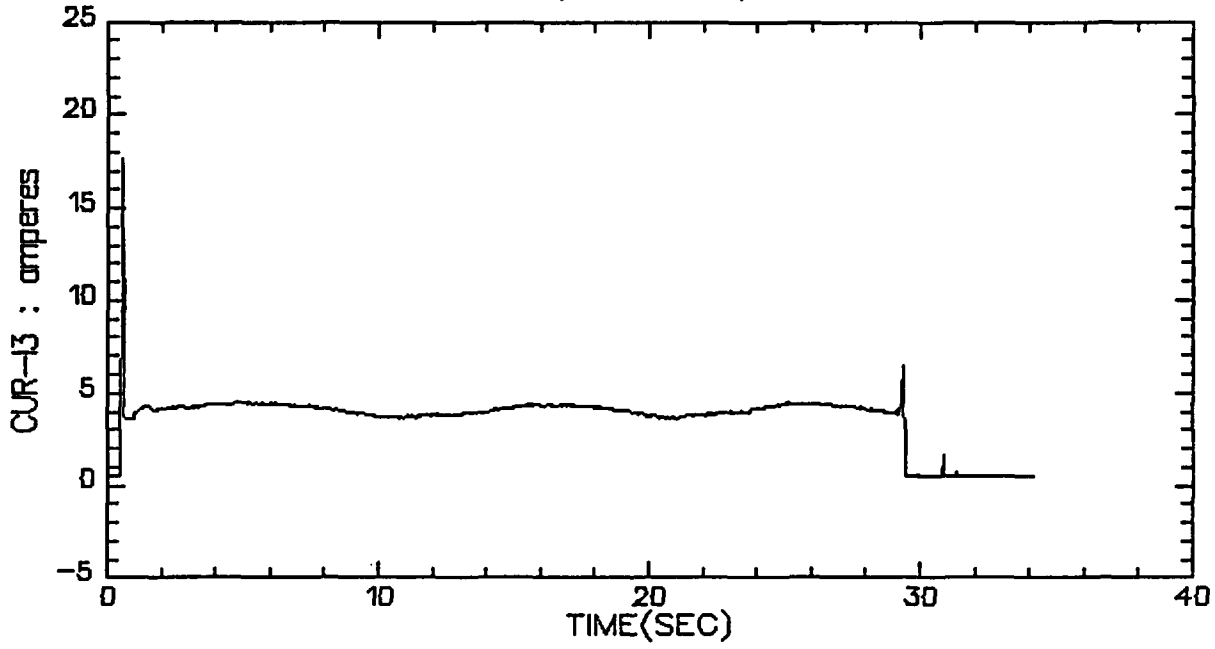

VALVE B, TEST 3, STEP 1

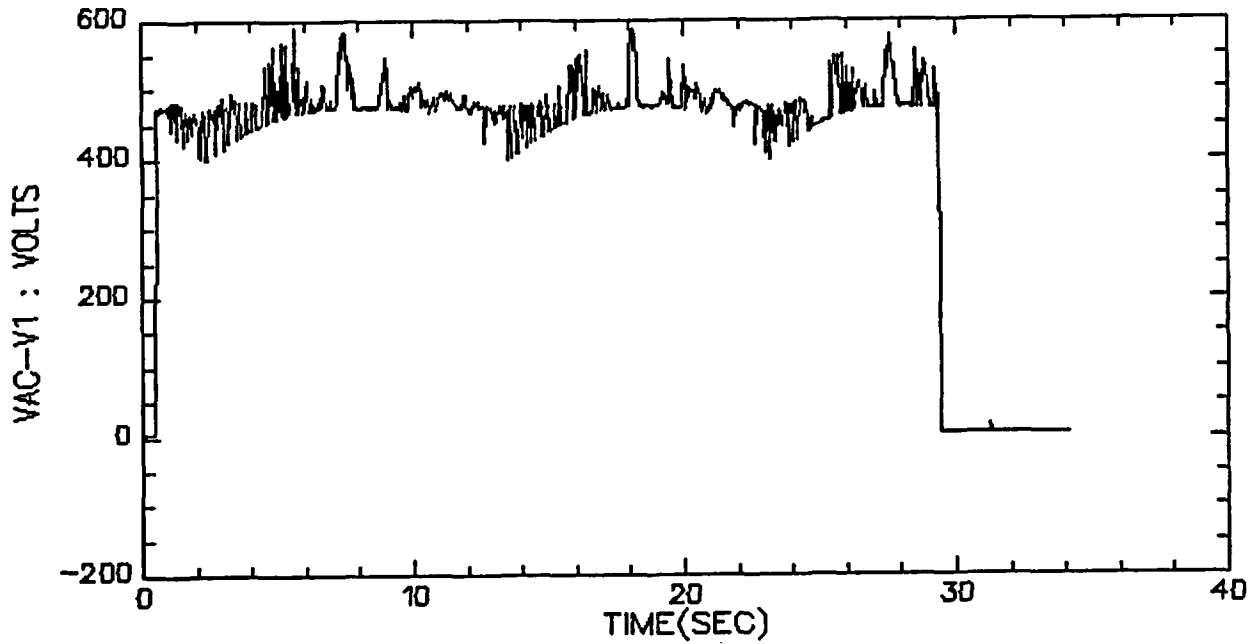

VALVE B, TEST 3, STEP 1

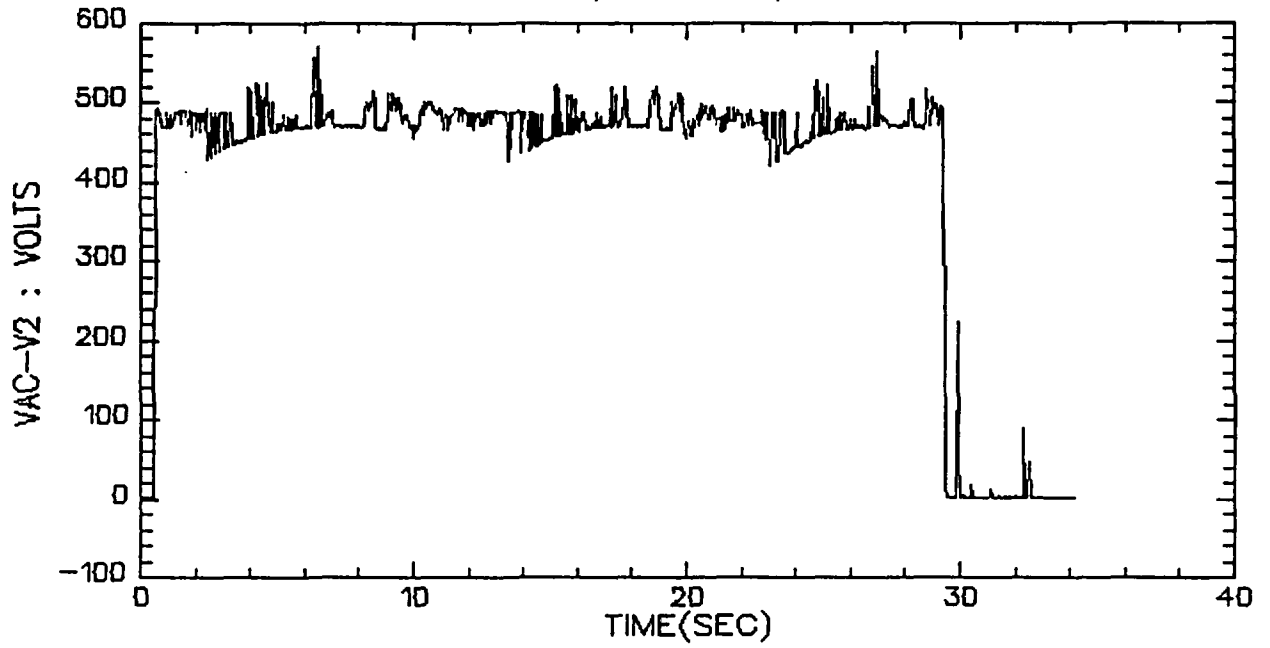

VALVE B, TEST 3, STEP 1

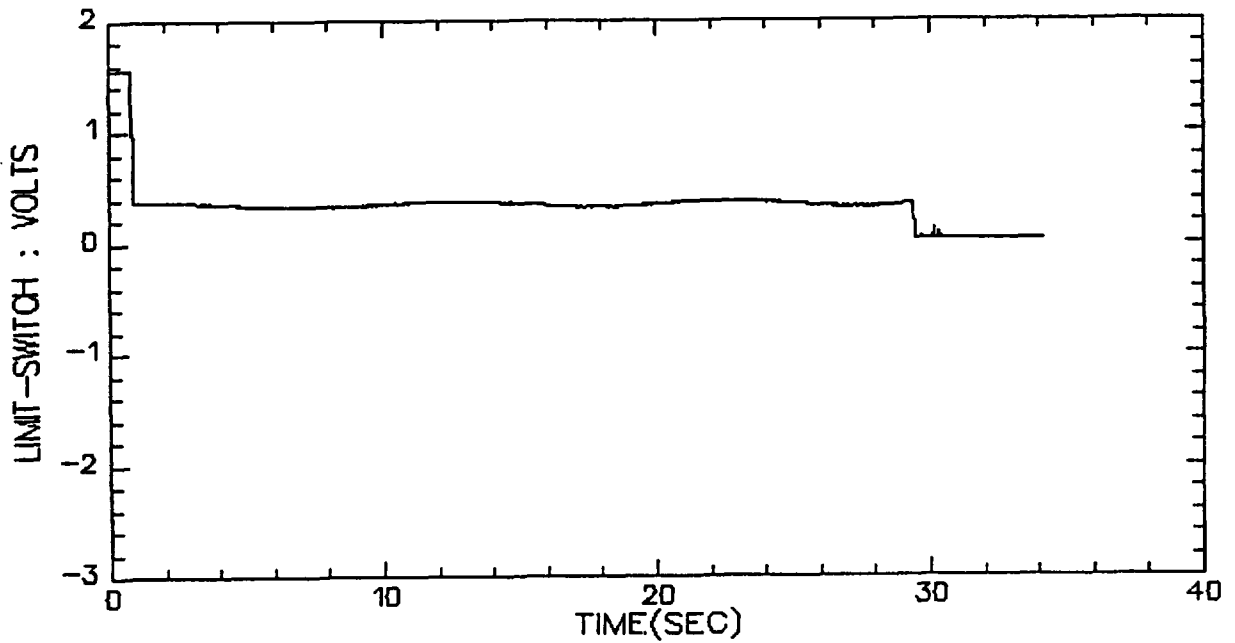

VALVE B, TEST 3, STEP 1

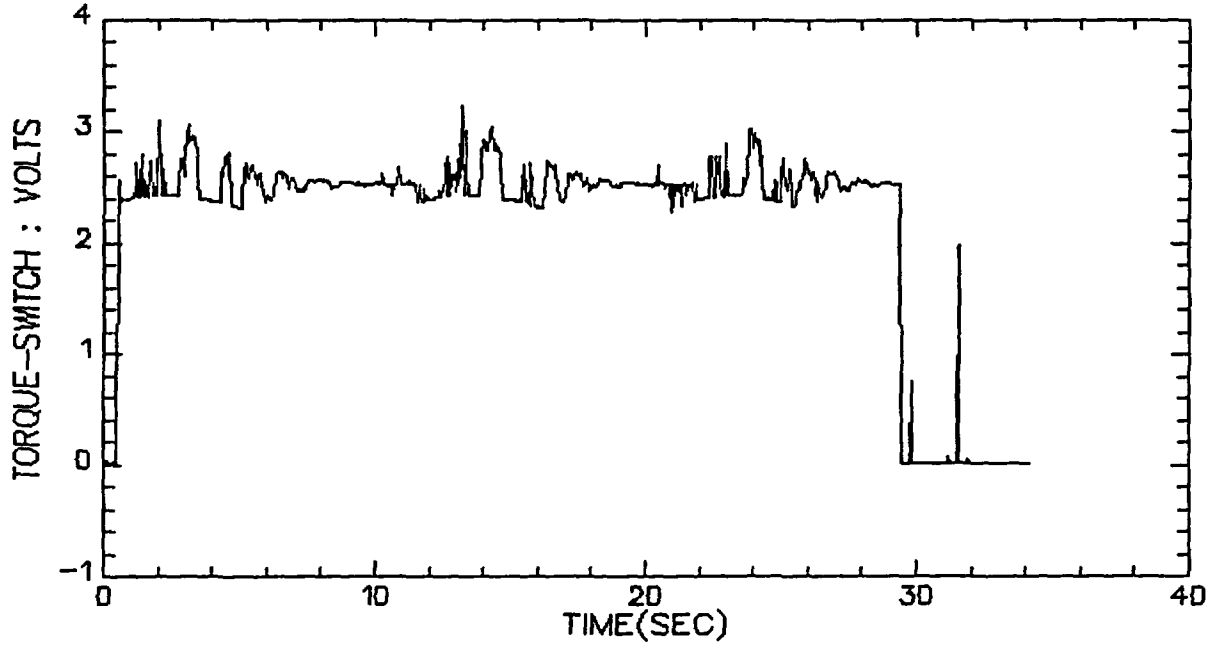

VALVE B, TEST 3, STEP 1

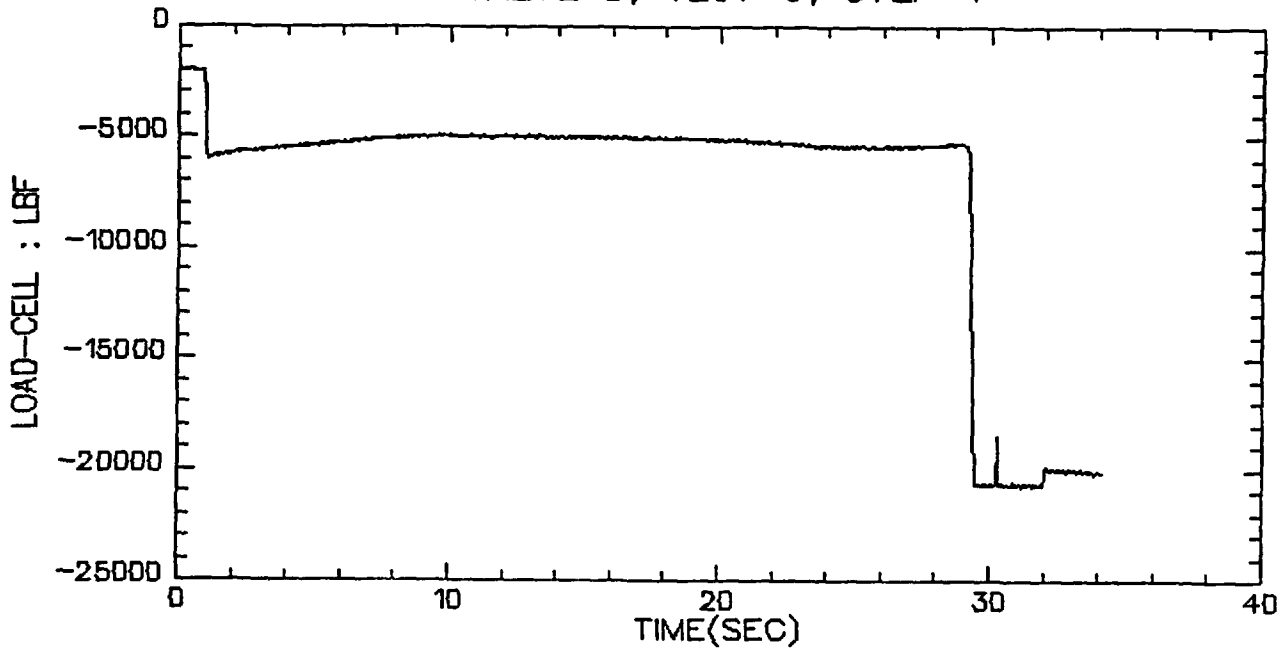

VALVE B, TEST 3, STEP 2

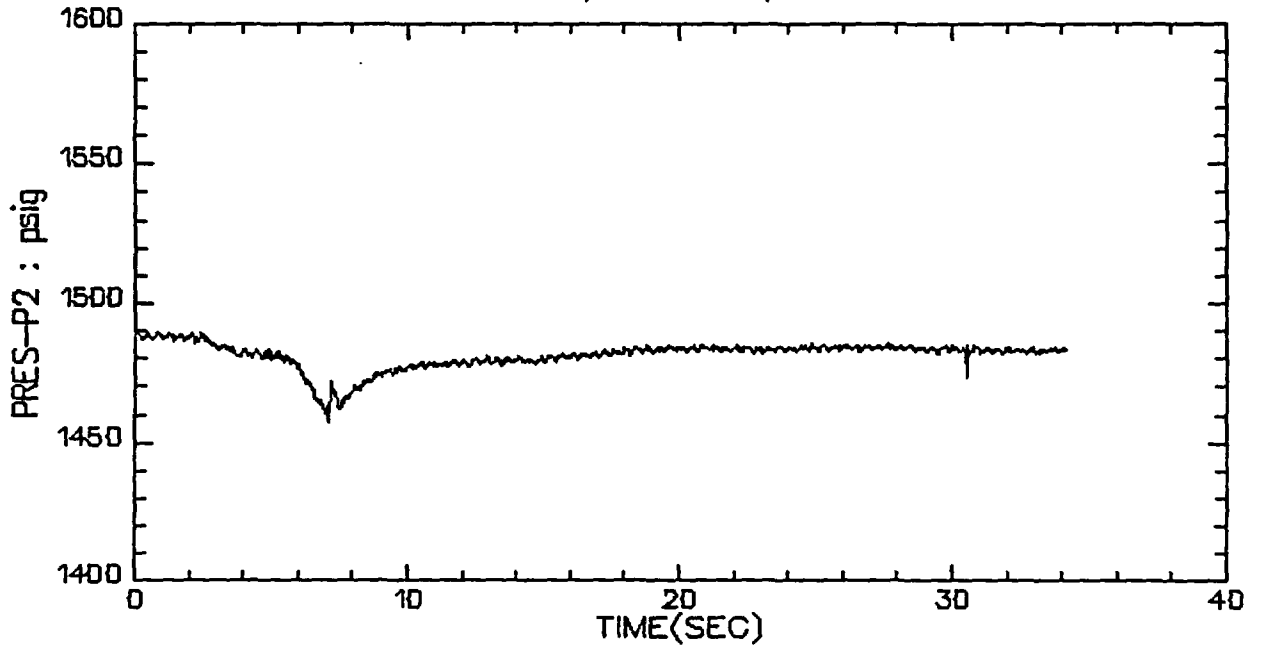

VALVE B, TEST 3, STEP 2

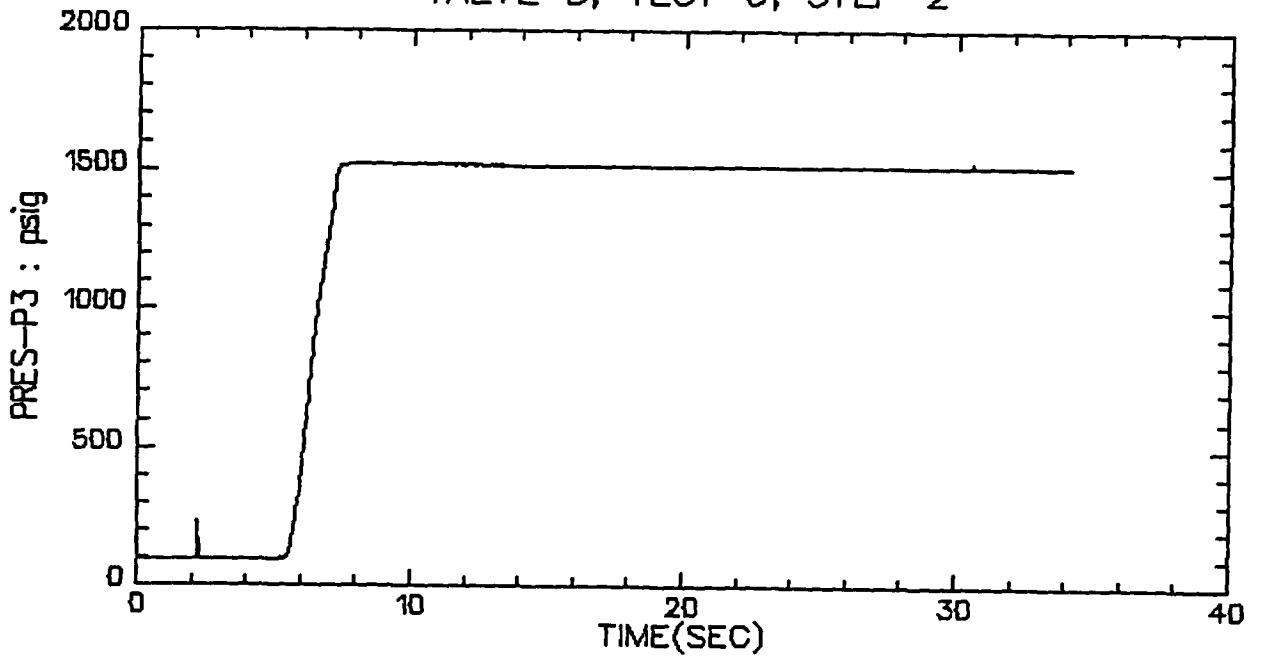

VALVE B, TEST 3, STEP 2

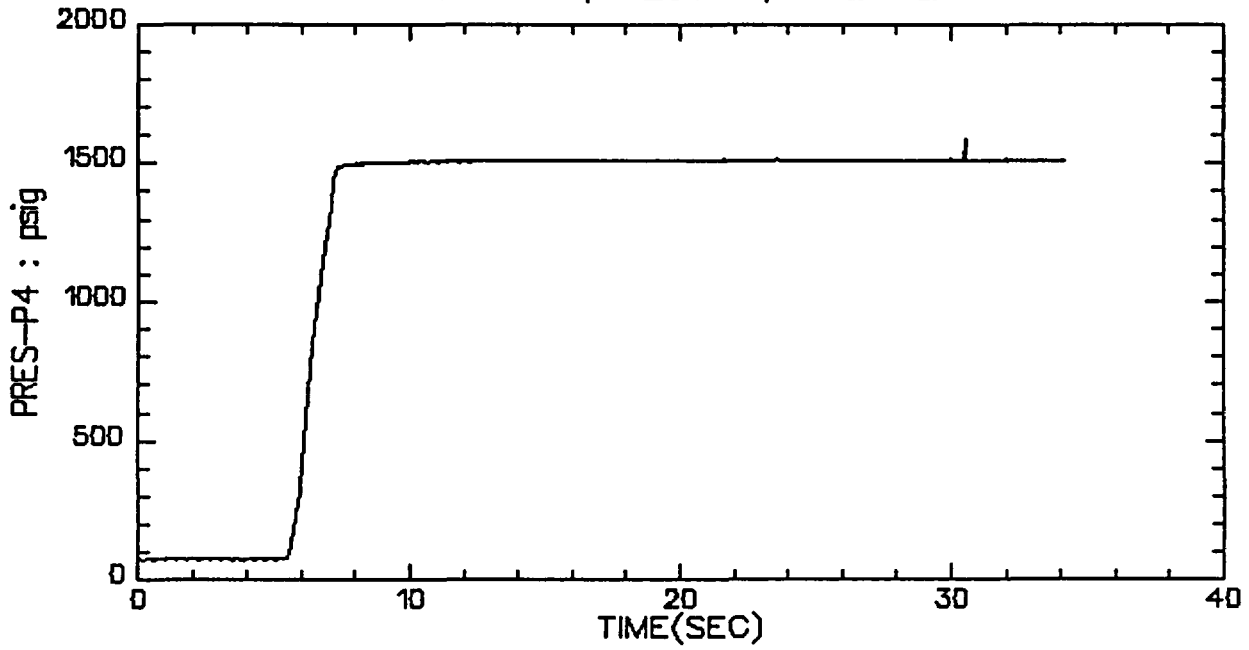

VALVE B, TEST 3, STEP 2

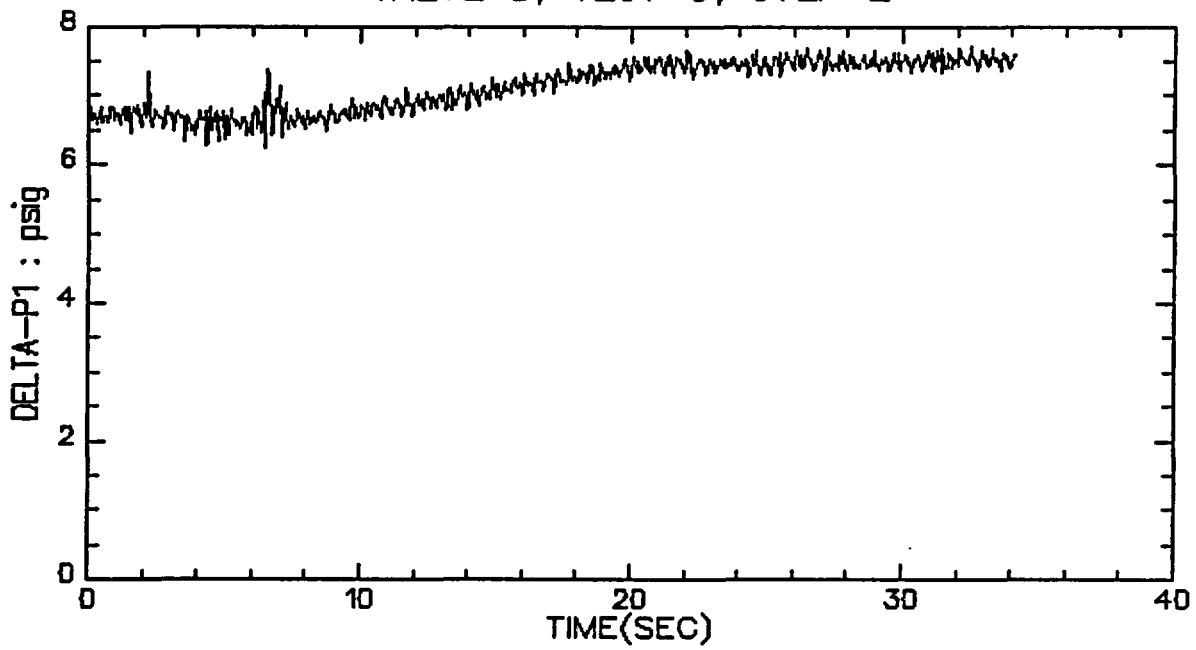

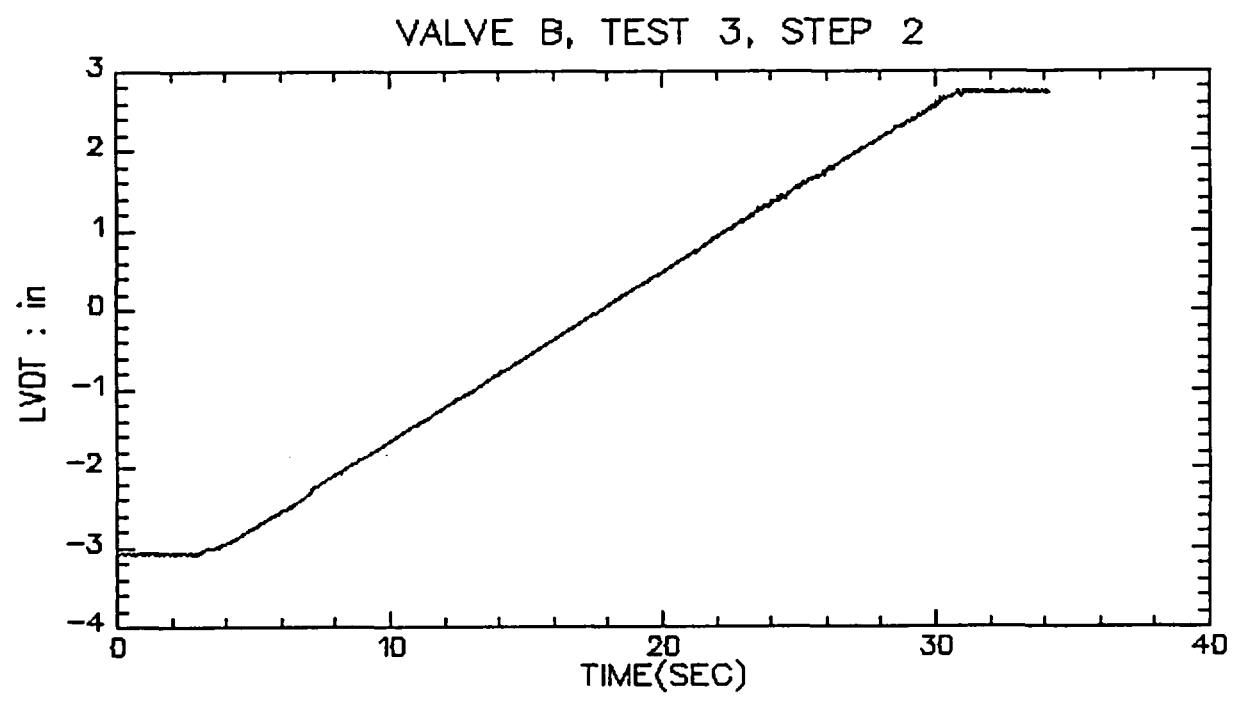
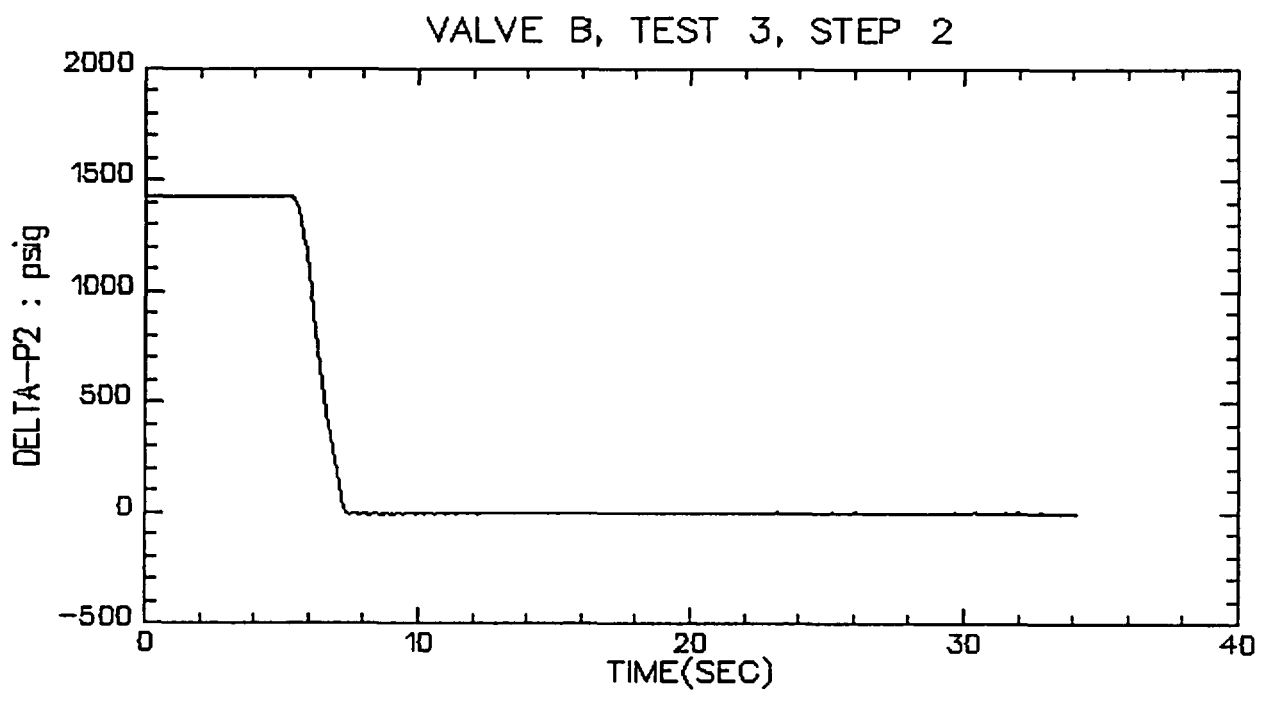

VALVE B, TEST 3, STEP 2

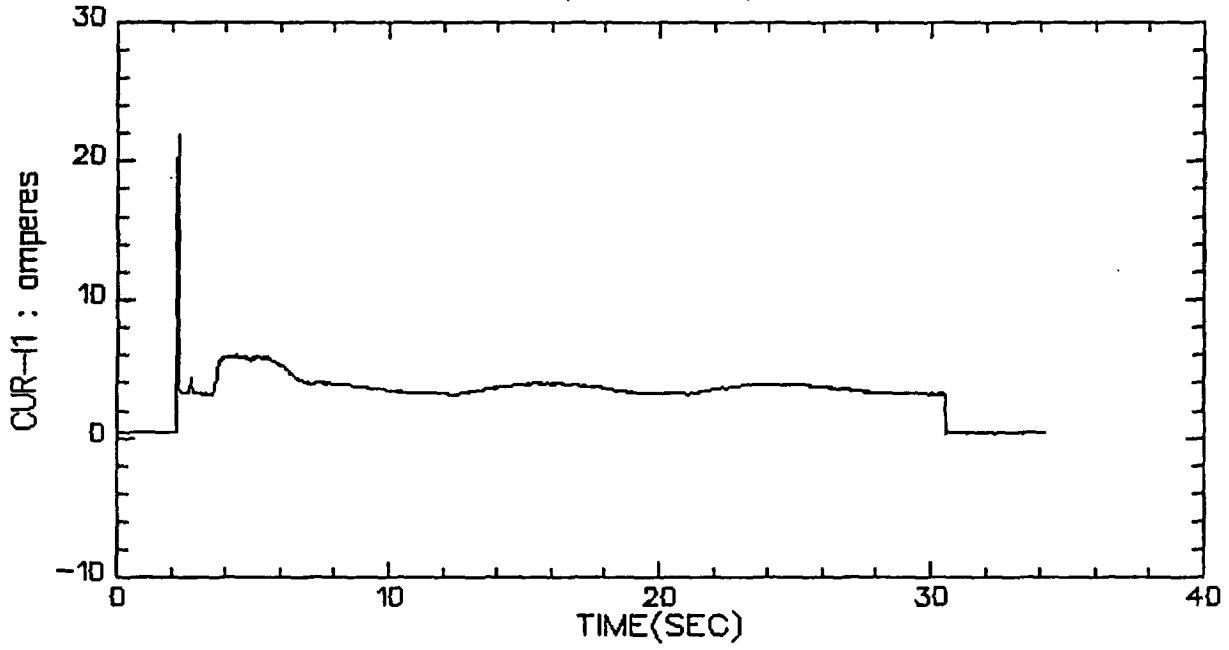

VALVE B, TEST 3, STEP 2

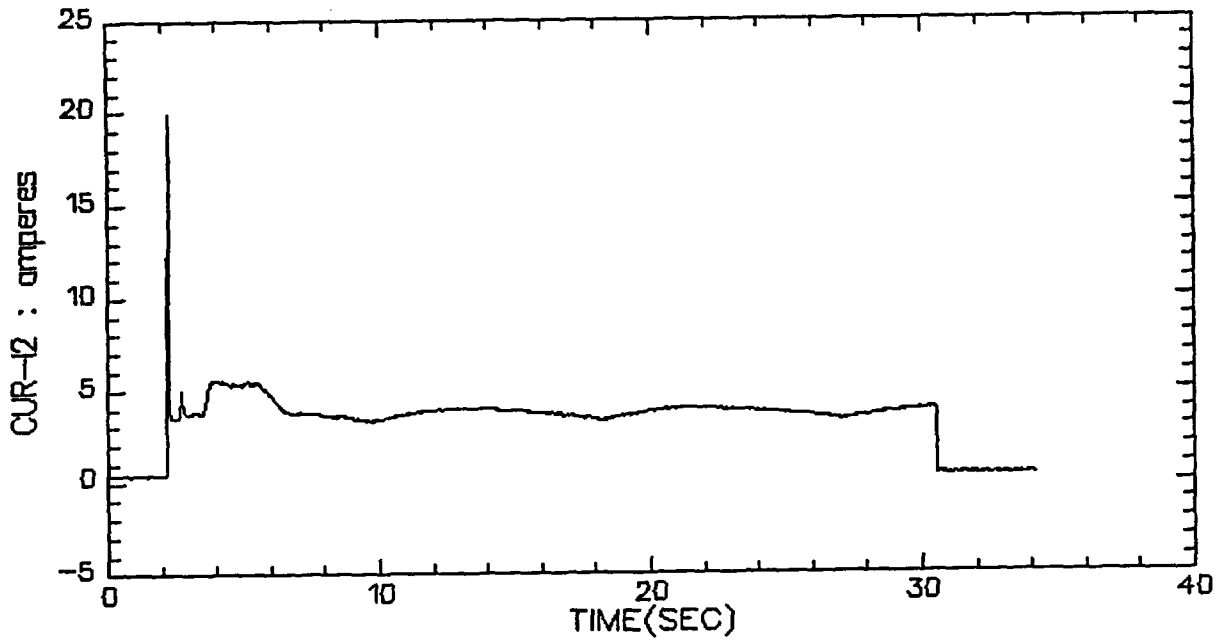

VALVE B, TEST 3, STEP 2

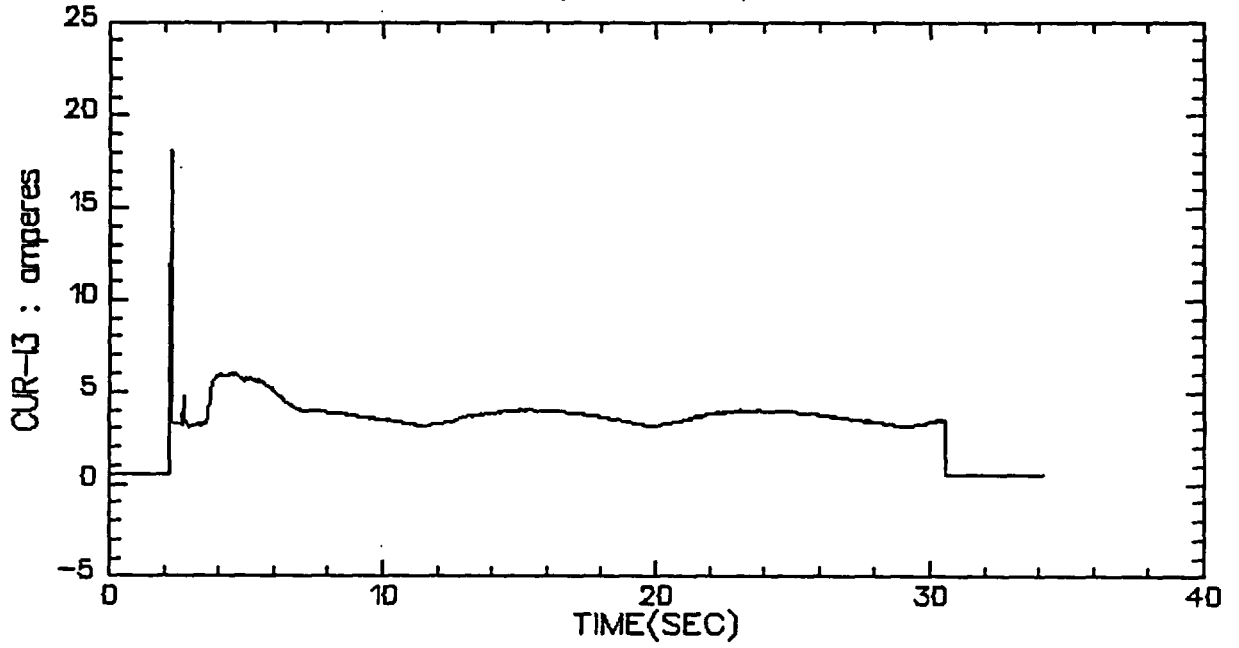

VALVE B, TEST 3, STEP 2

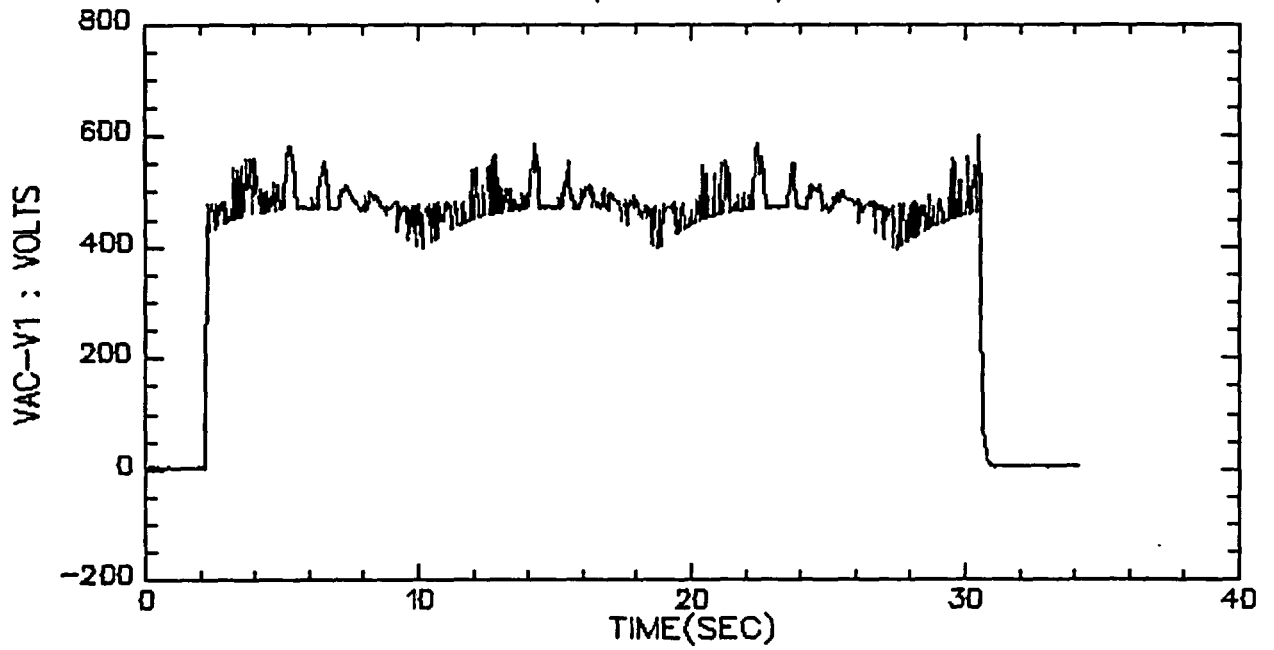

VALVE B, TEST 3, STEP 2

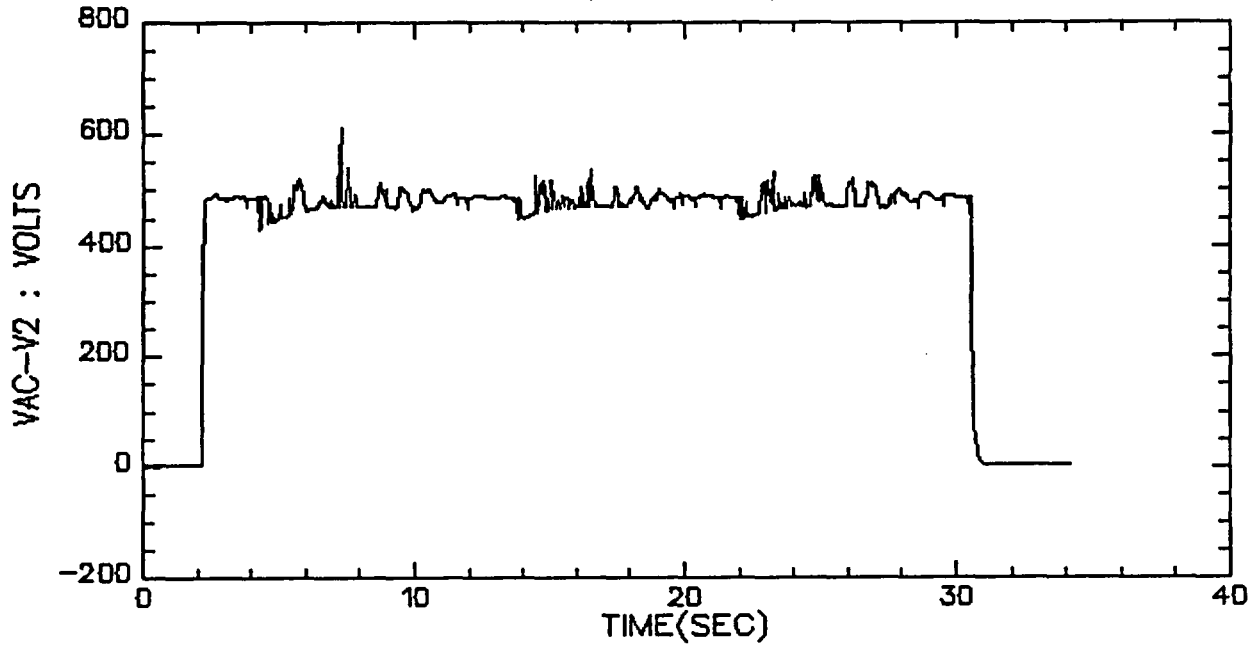

VALVE B, TEST 3, STEP 2

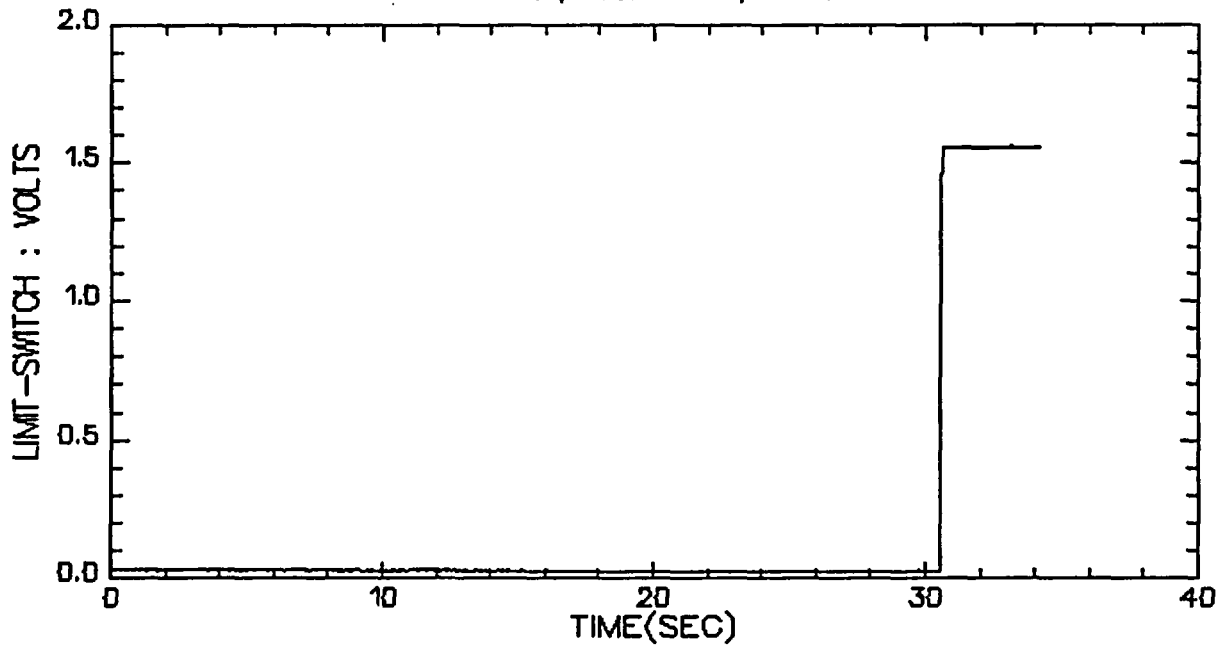

VALVE B, TEST 3, STEP 2

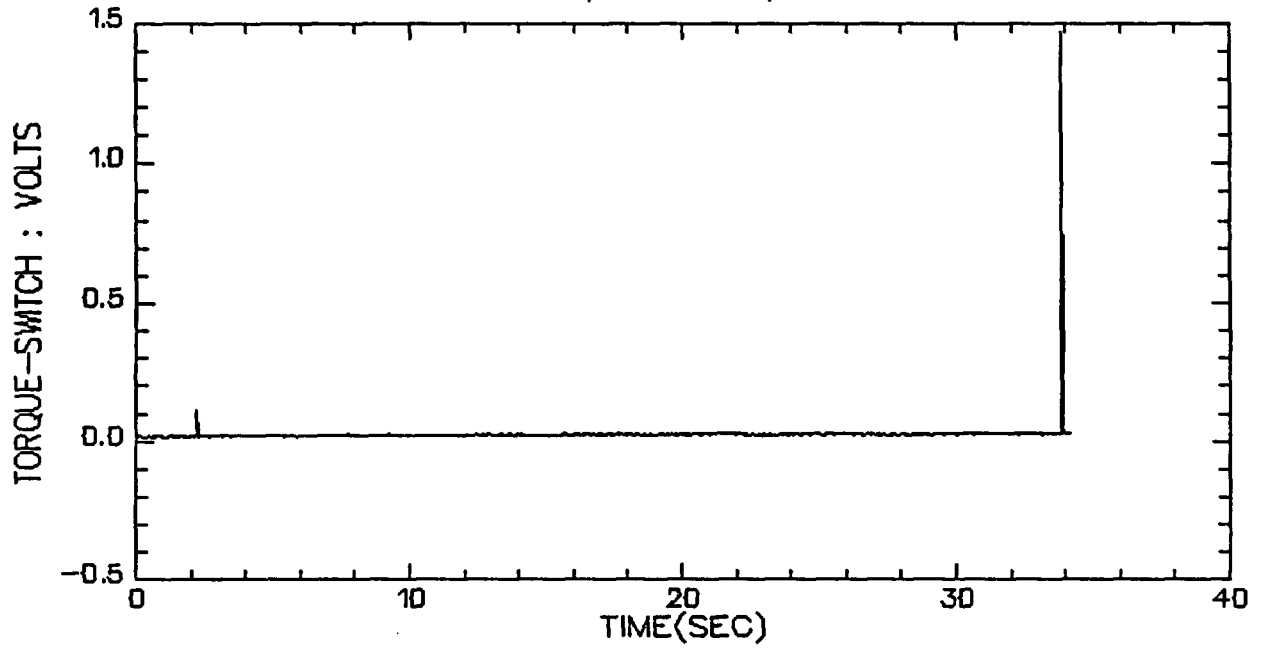

VALVE B, TEST 3, STEP 2

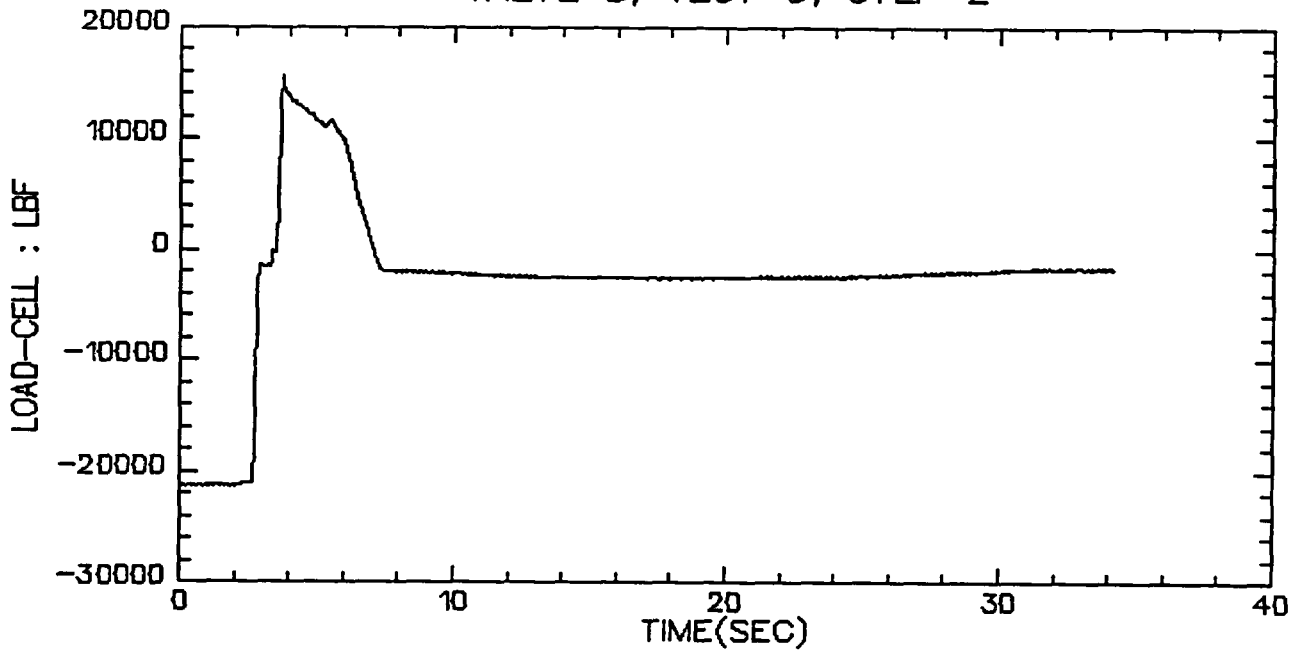

VALVE B, TEST 3, STEP 3&4

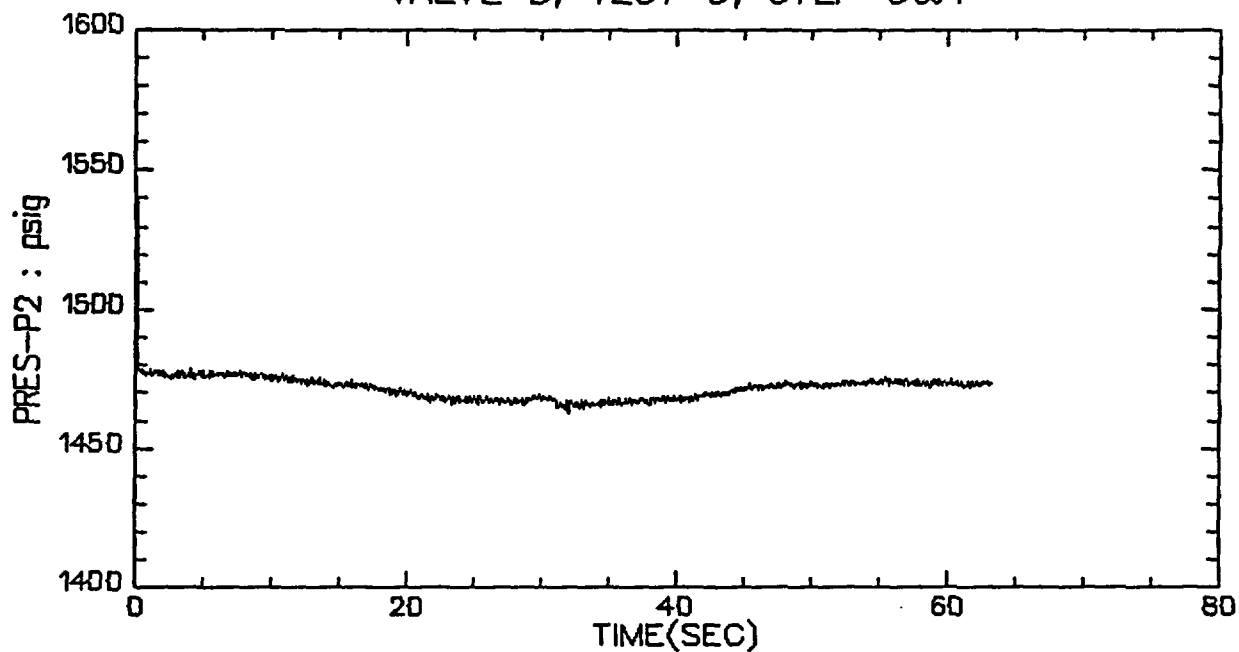

VALVE B, TEST 3, STEP 3&4

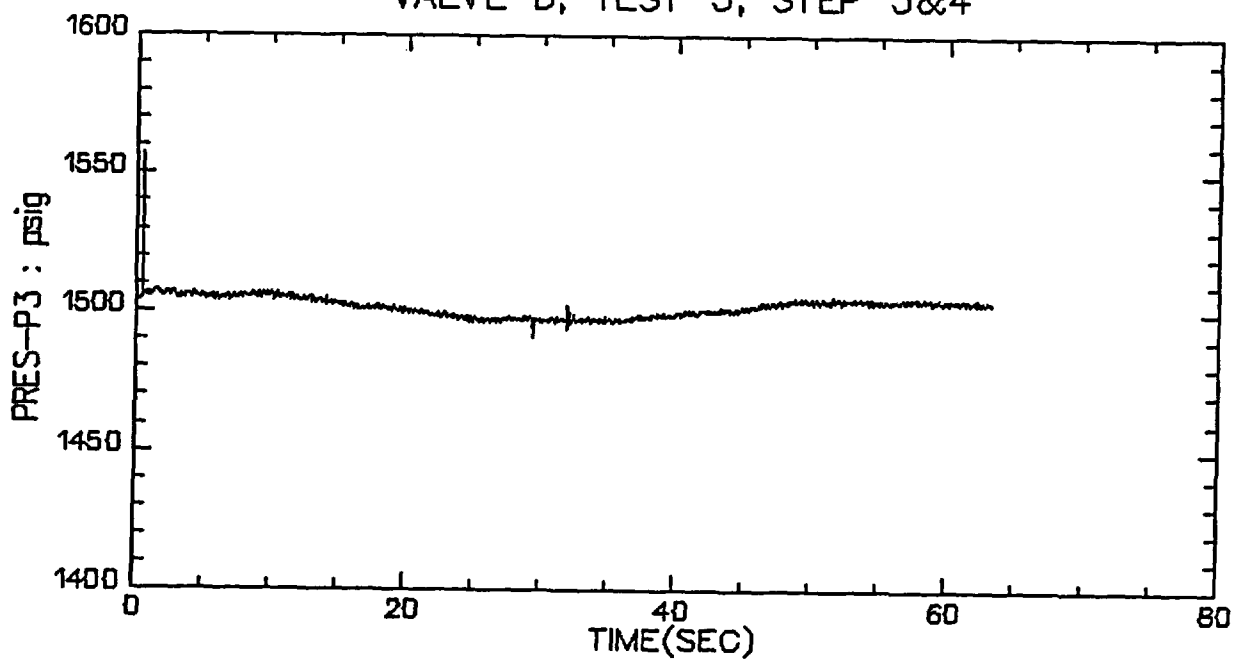

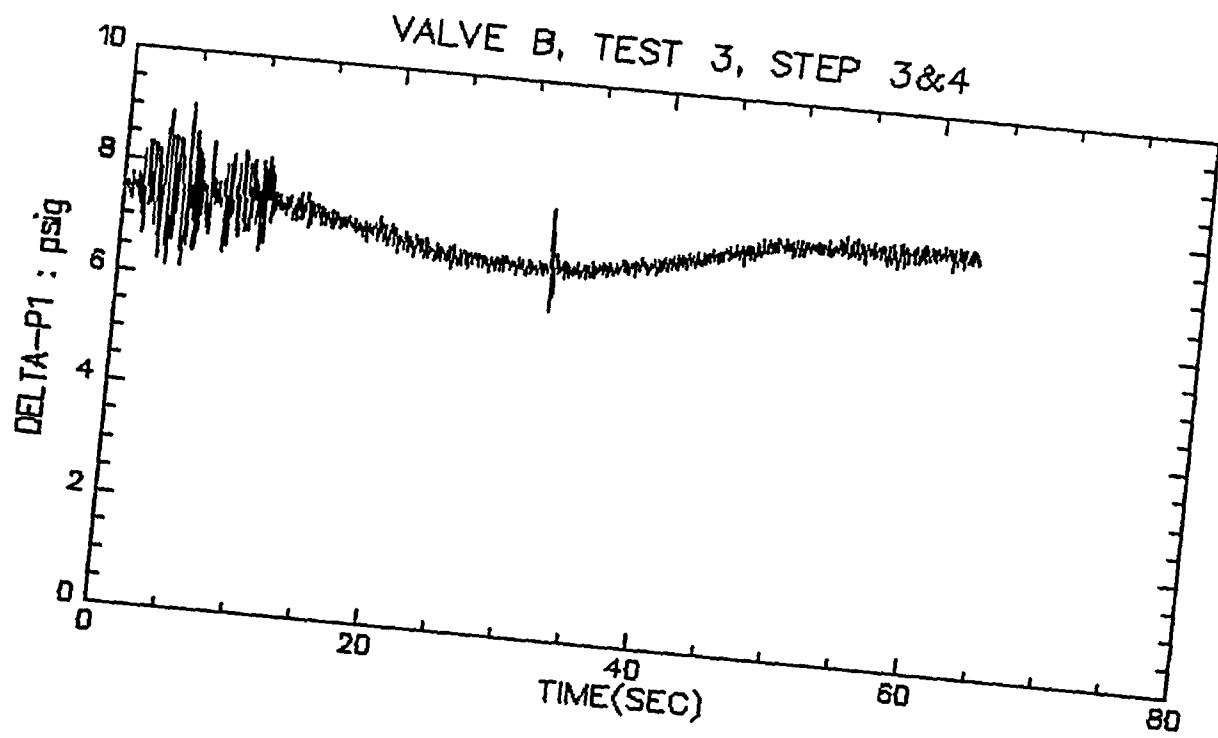
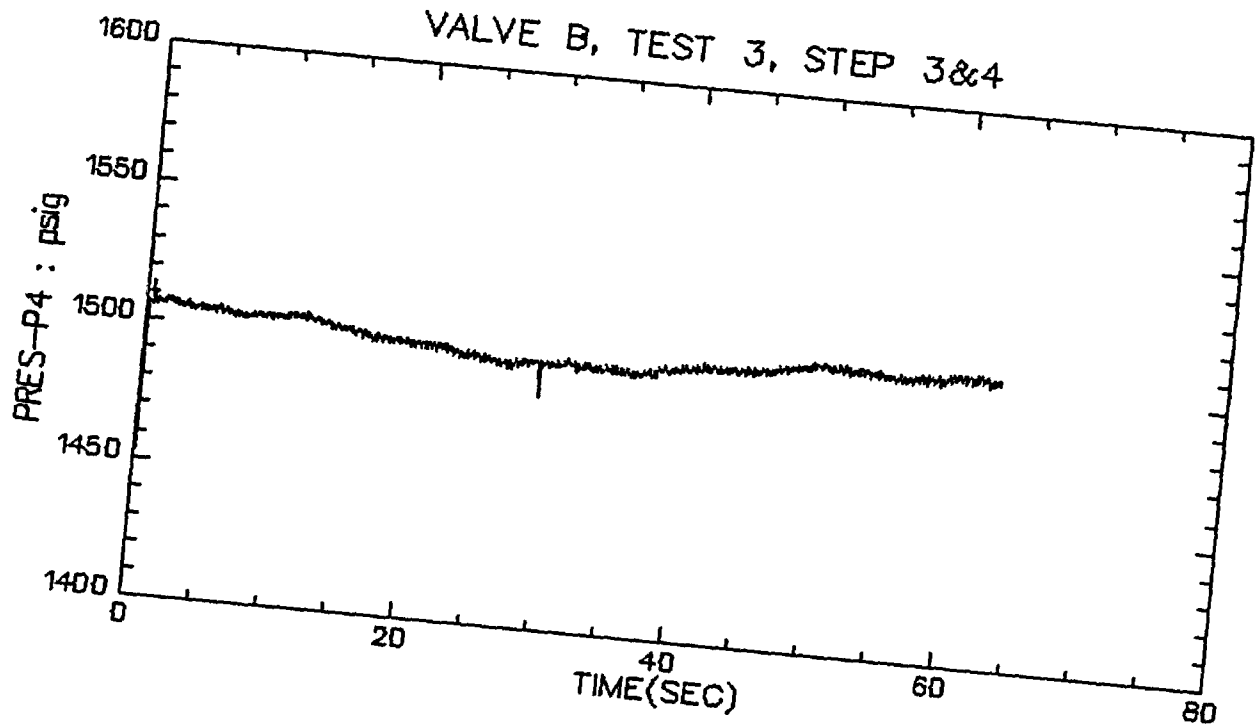

VALVE B, TEST 3, STEP 3&4

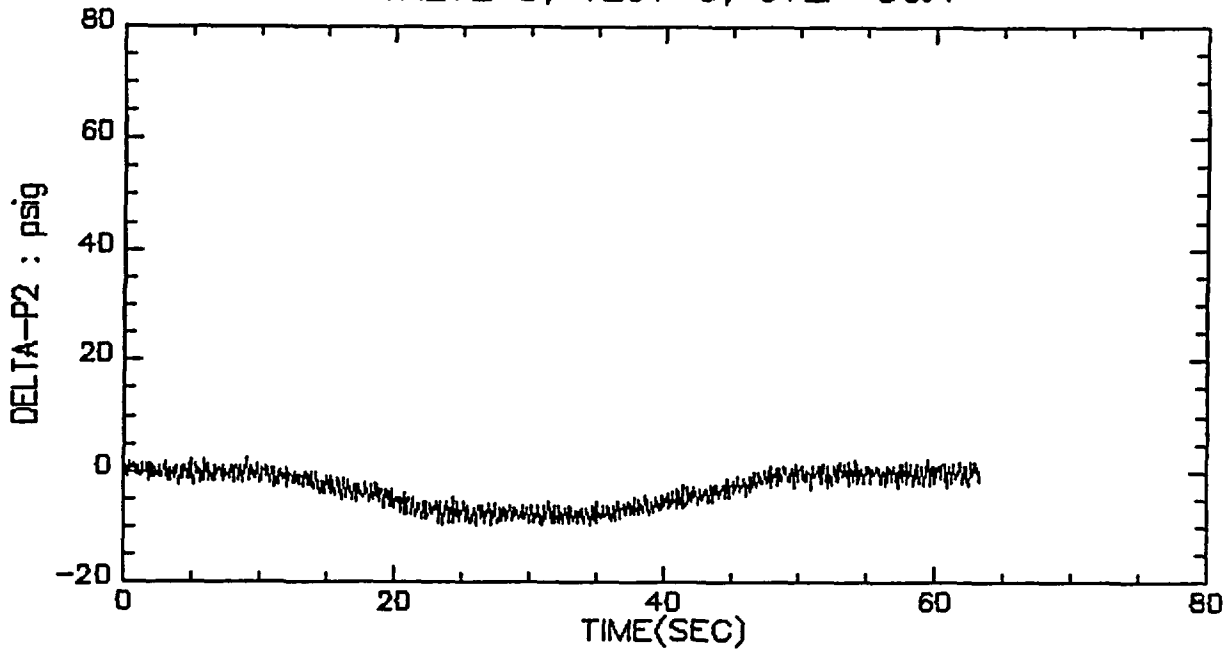

VALVE B, TEST 3, STEP 3&4

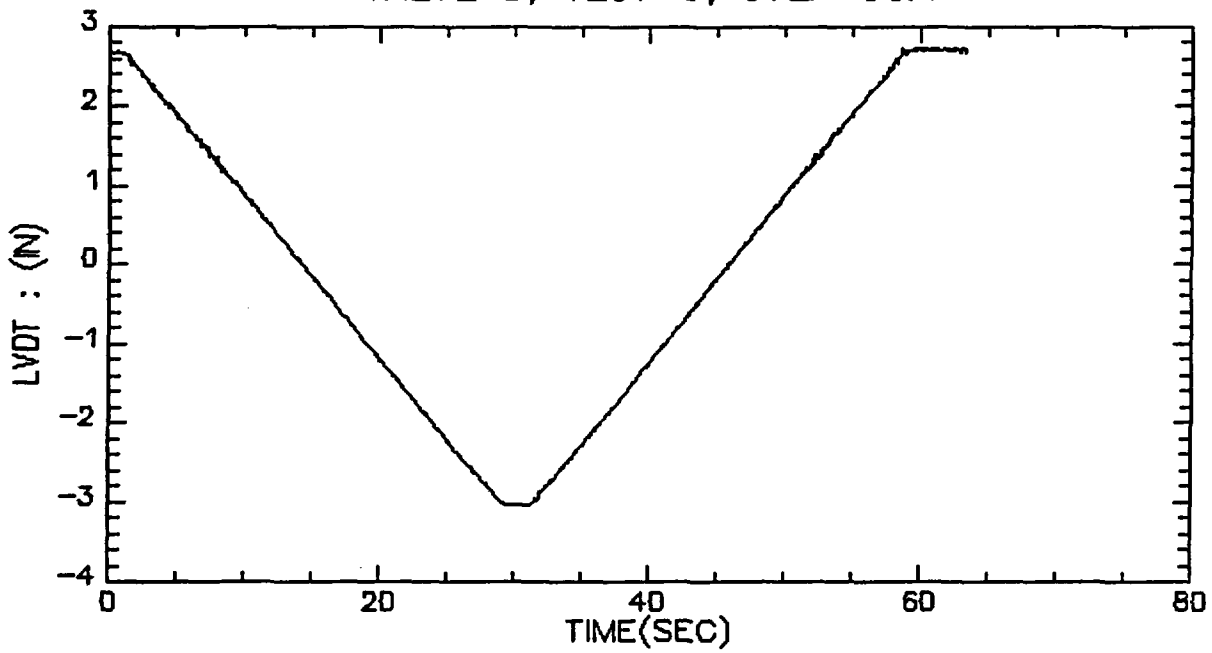

VALVE B, TEST 3, STEP 3&4

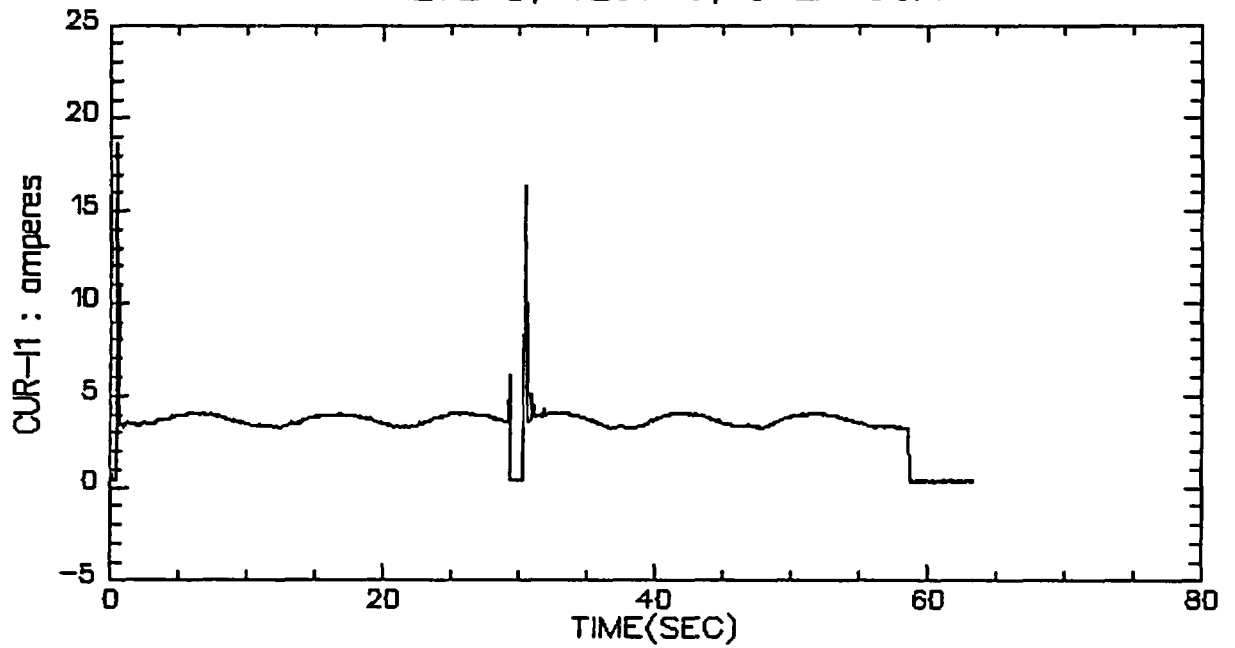

VALVE B, TEST 3, STEP 3&4

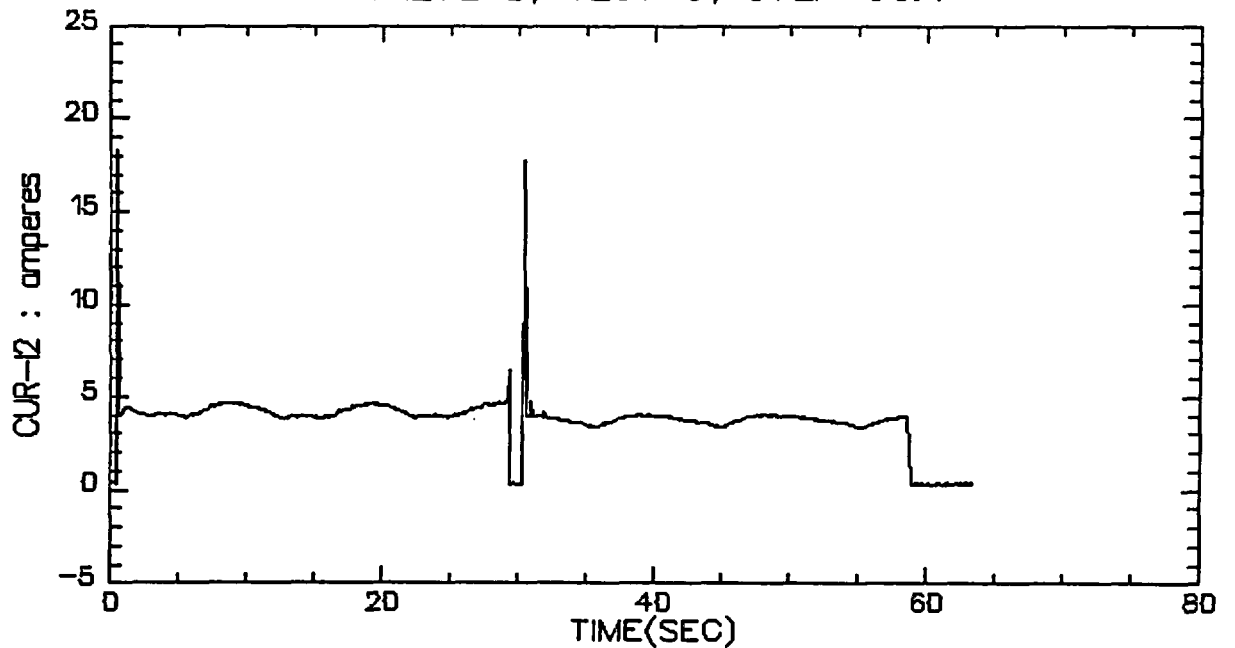

VALVE B, TEST 3, STEP 3&4

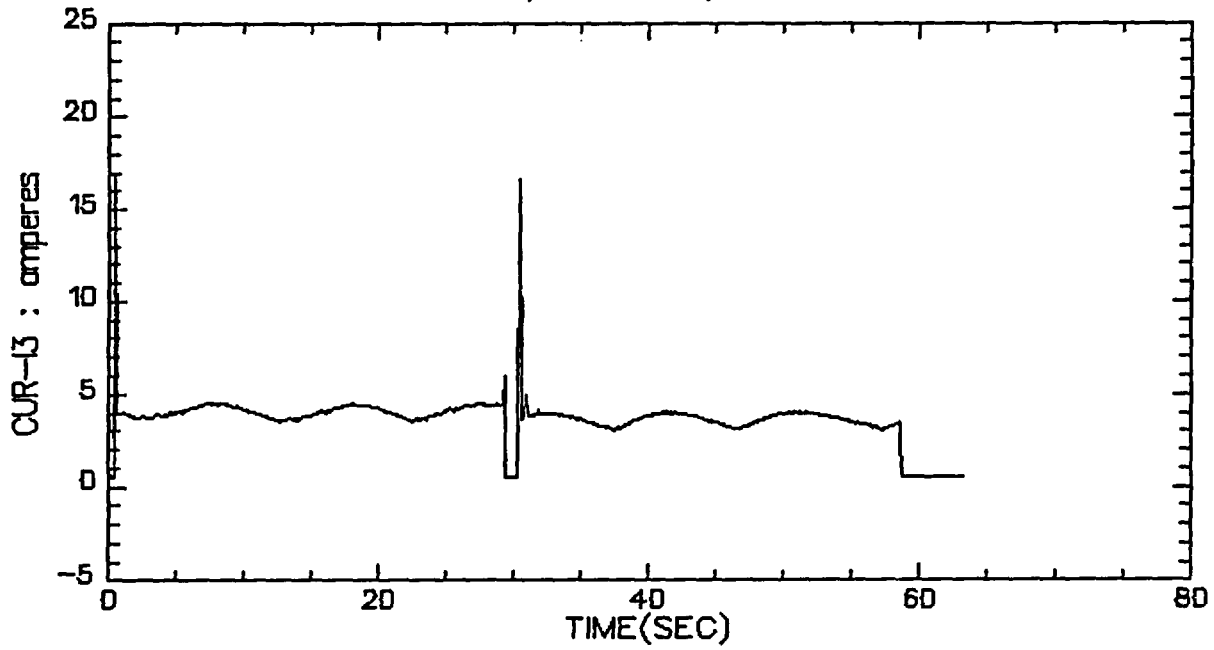

VALVE B, TEST 3, STEP 3&4

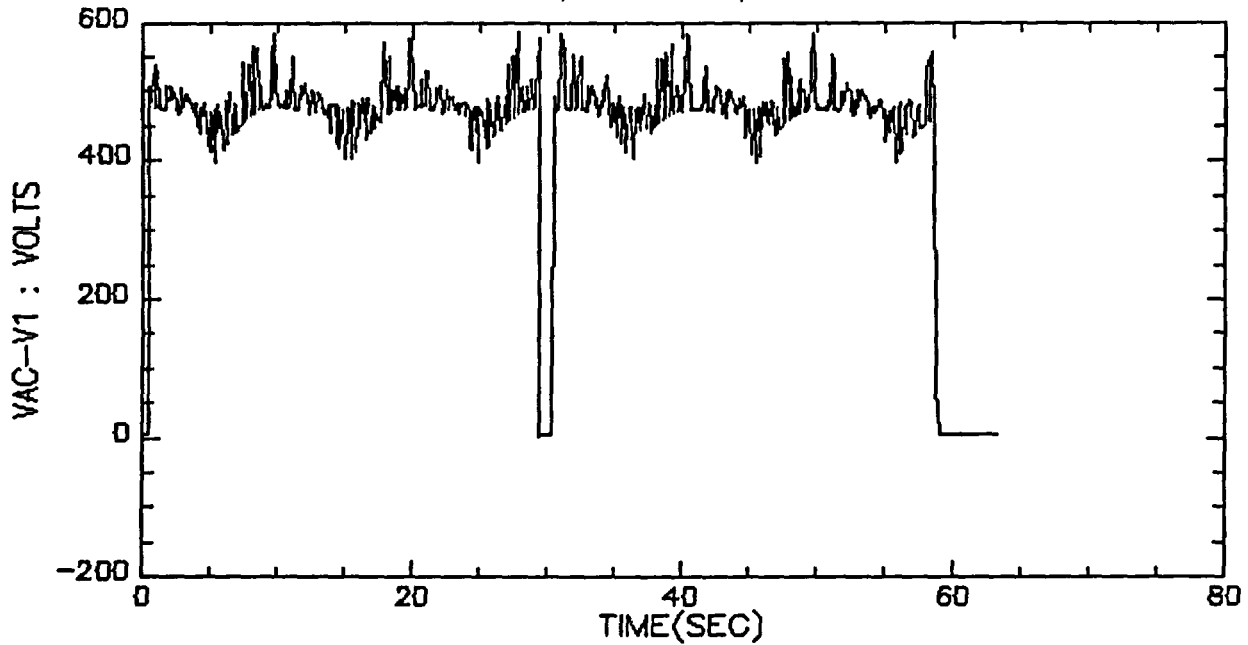

VALVE B, TEST 3, STEP 3&4

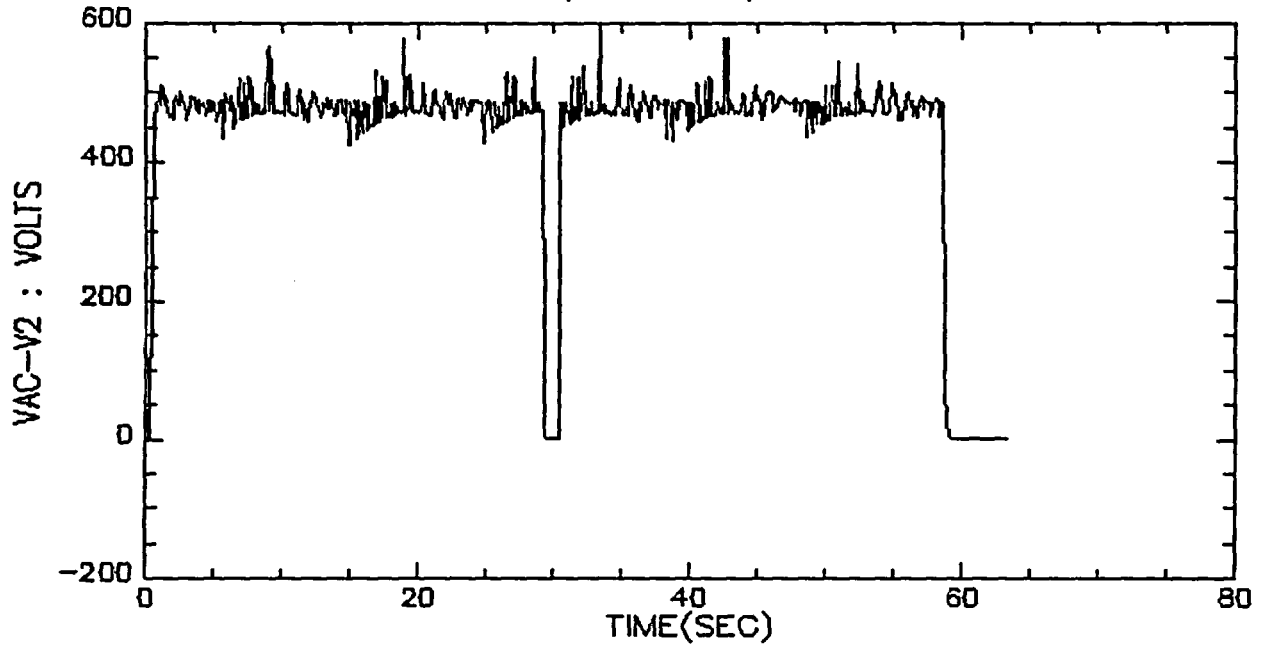

VALVE B, TEST 3, STEP 3&4

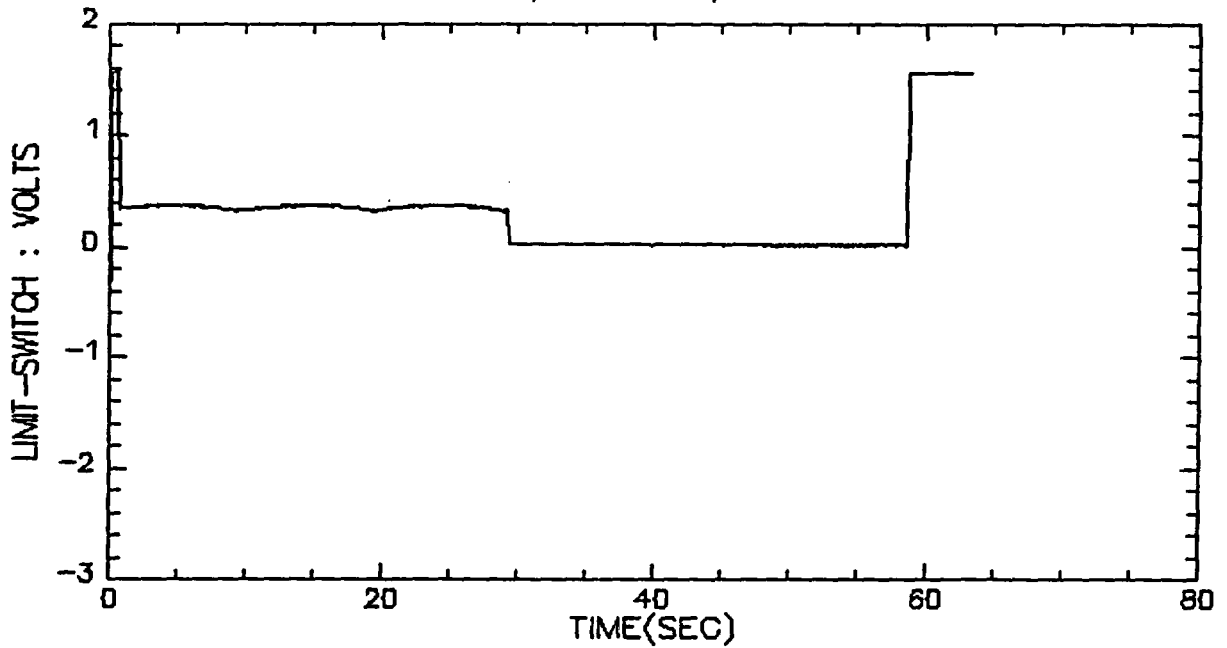

VALVE B, TEST 3, STEP 3&4

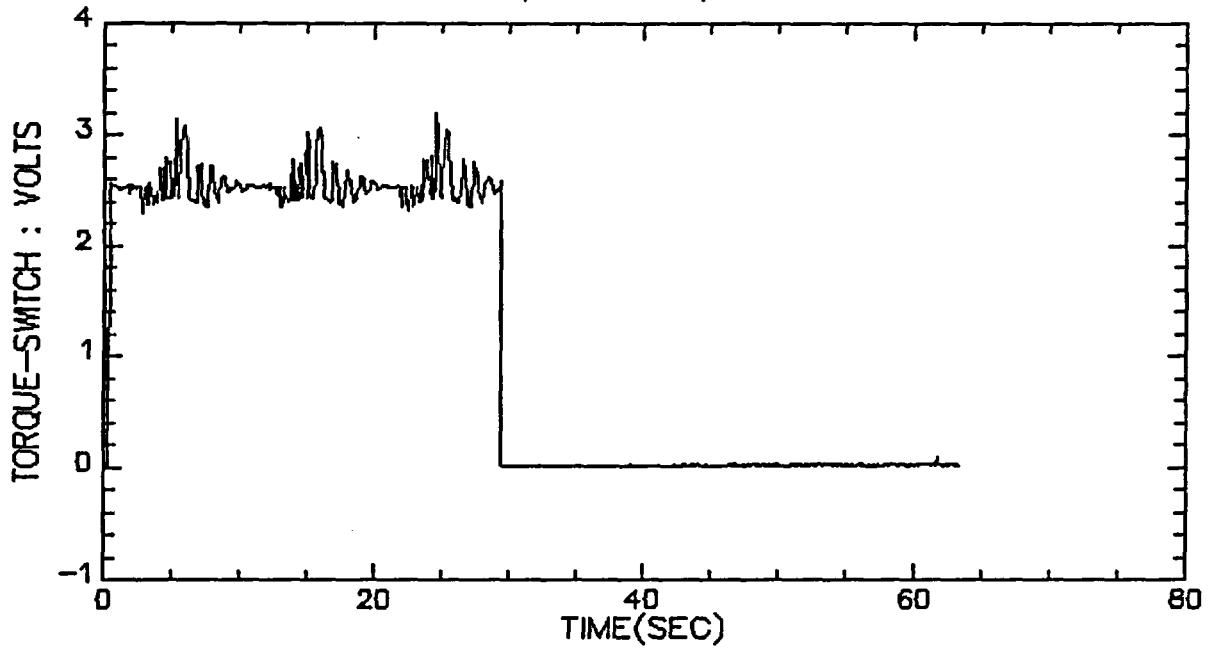

VALVE B, TEST 3, STEP 3&4

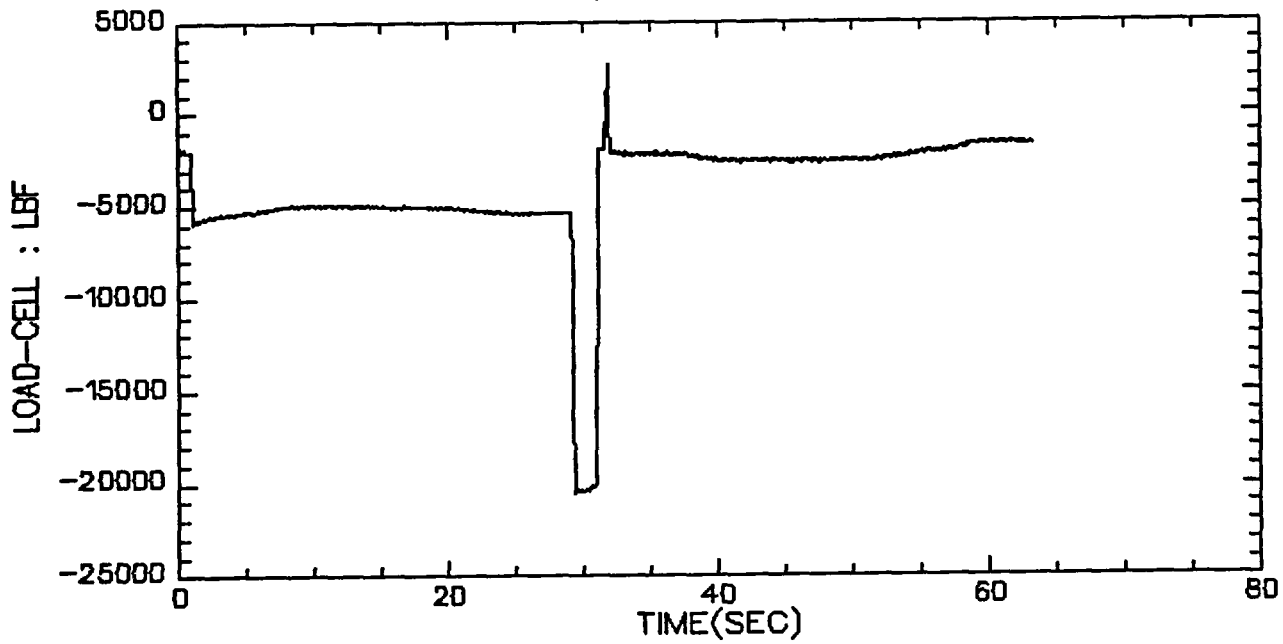

VALVE B, TEST 3, STEP 5

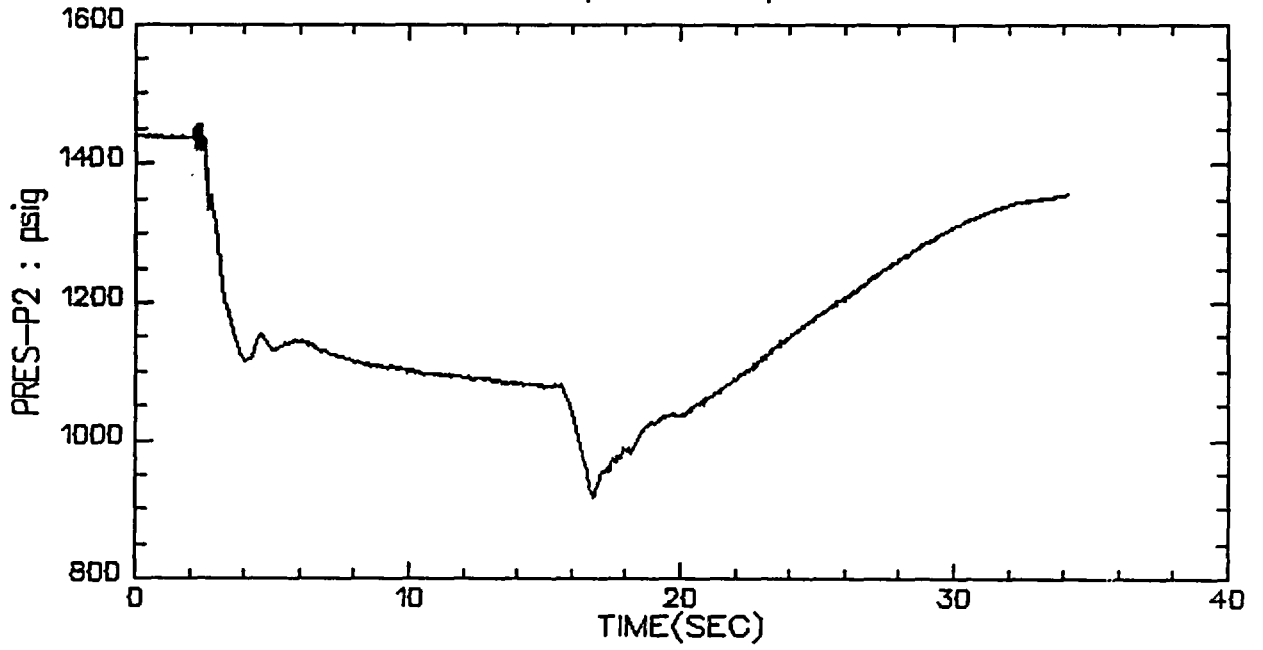

VALVE B, TEST 3, STEP 5

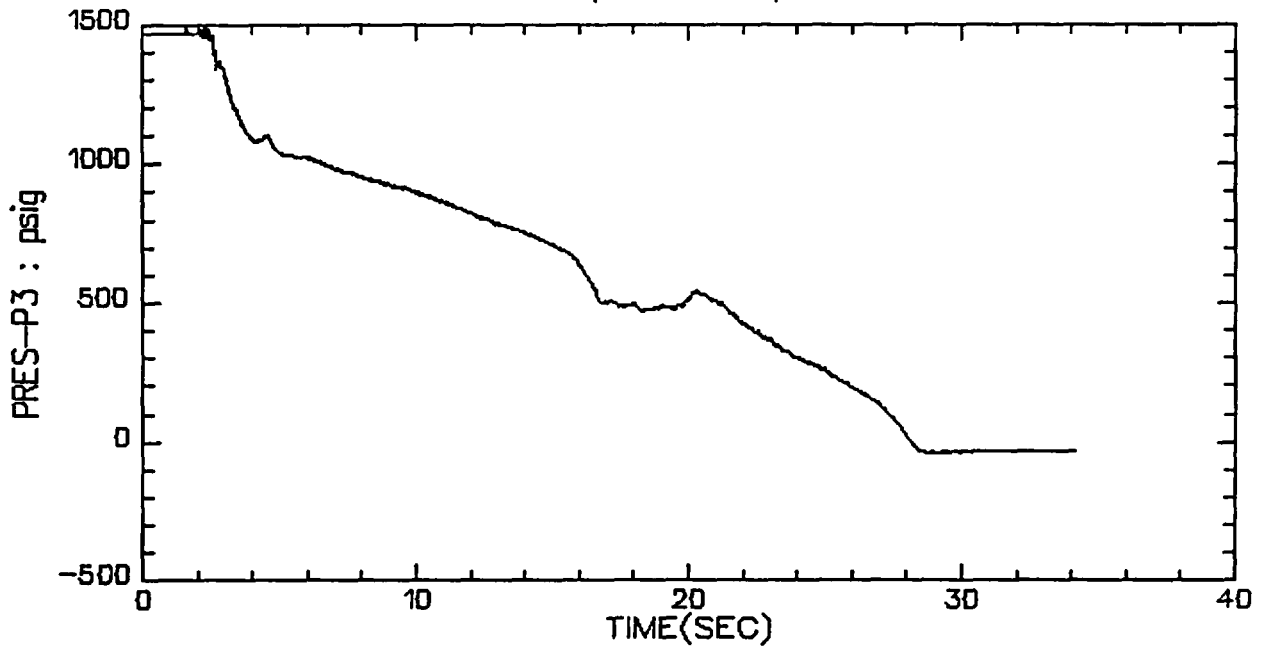

VALVE B, TEST 3, STEP 5

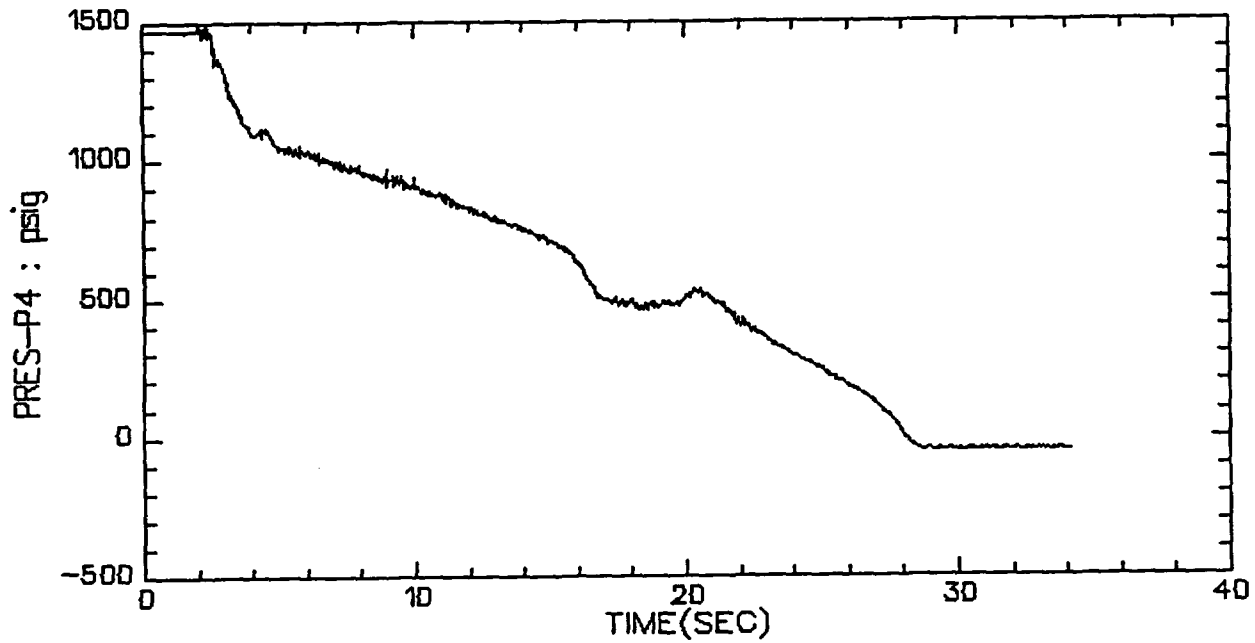

VALVE B, TEST 3, STEP 5

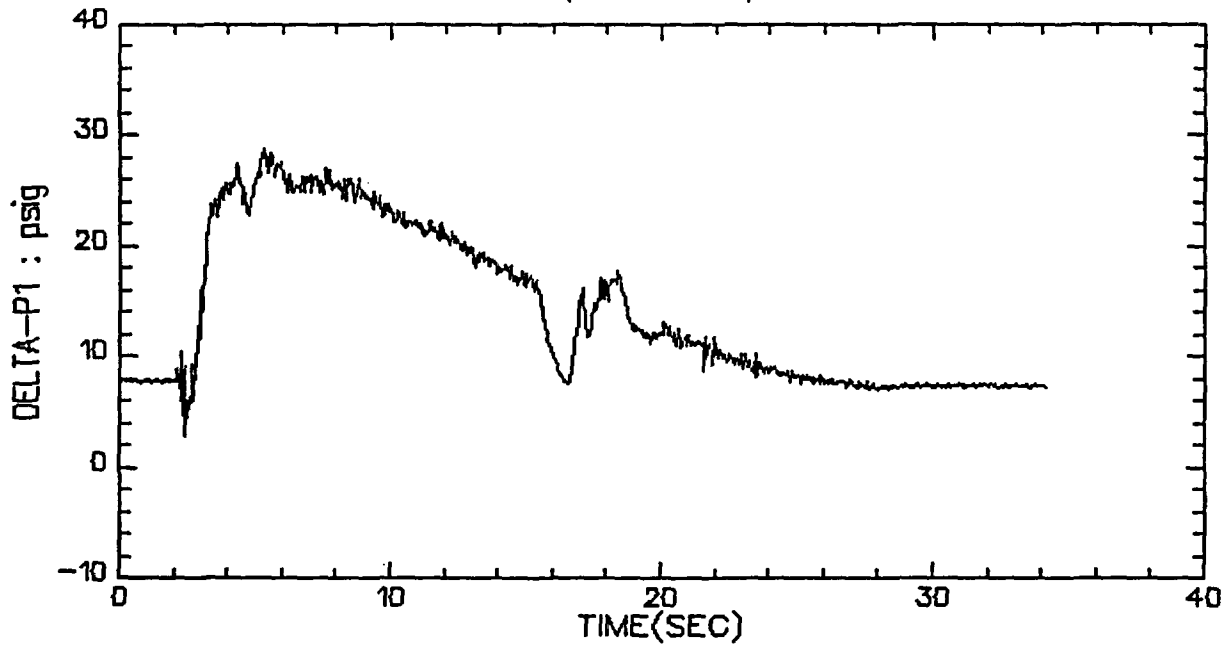

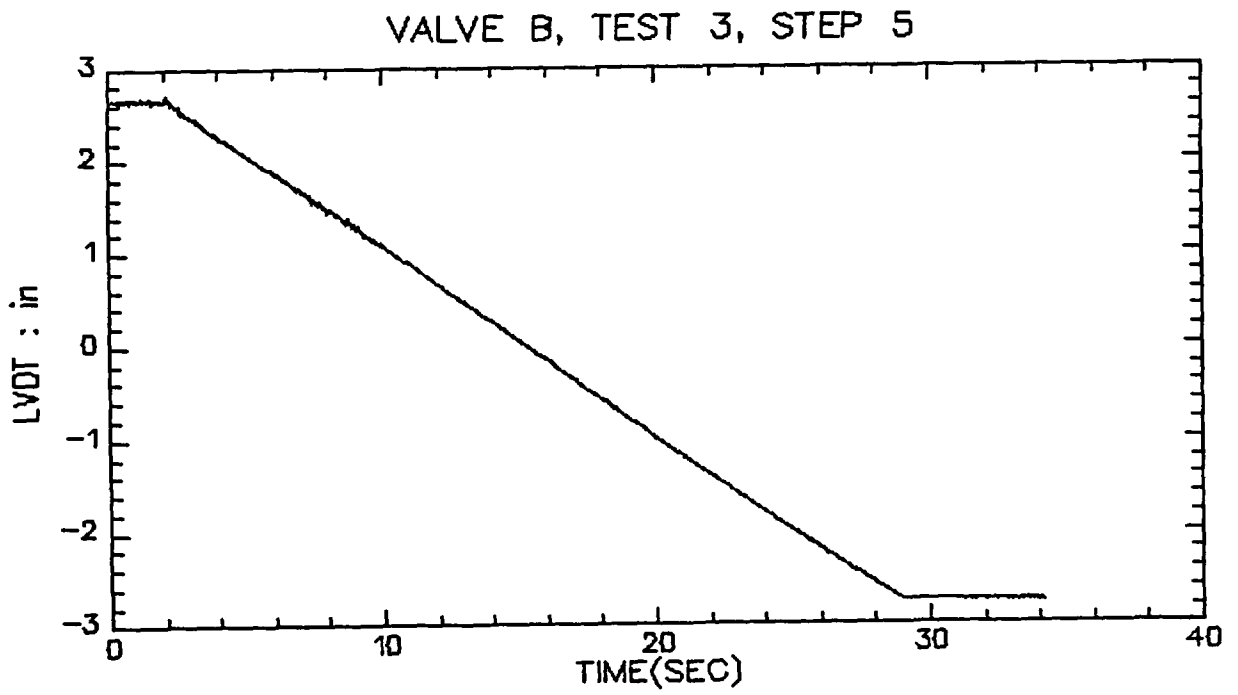
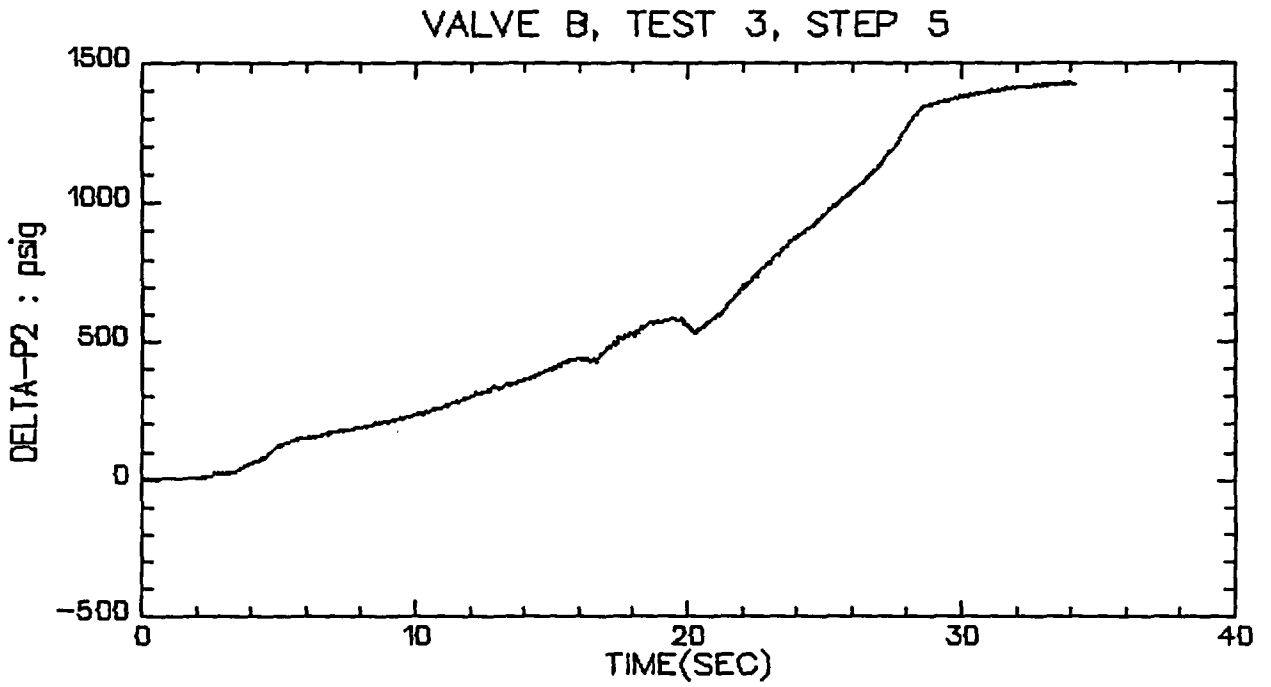

VALVE B, TEST 3, STEP 5

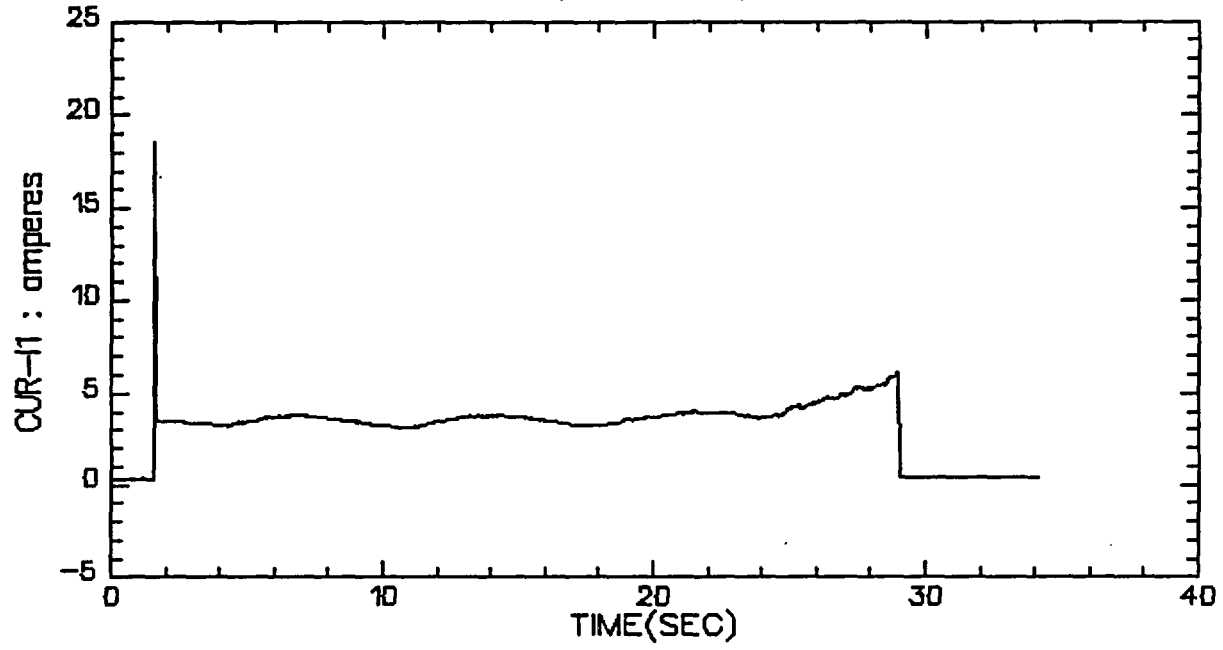

VALVE B, TEST 3, STEP 5

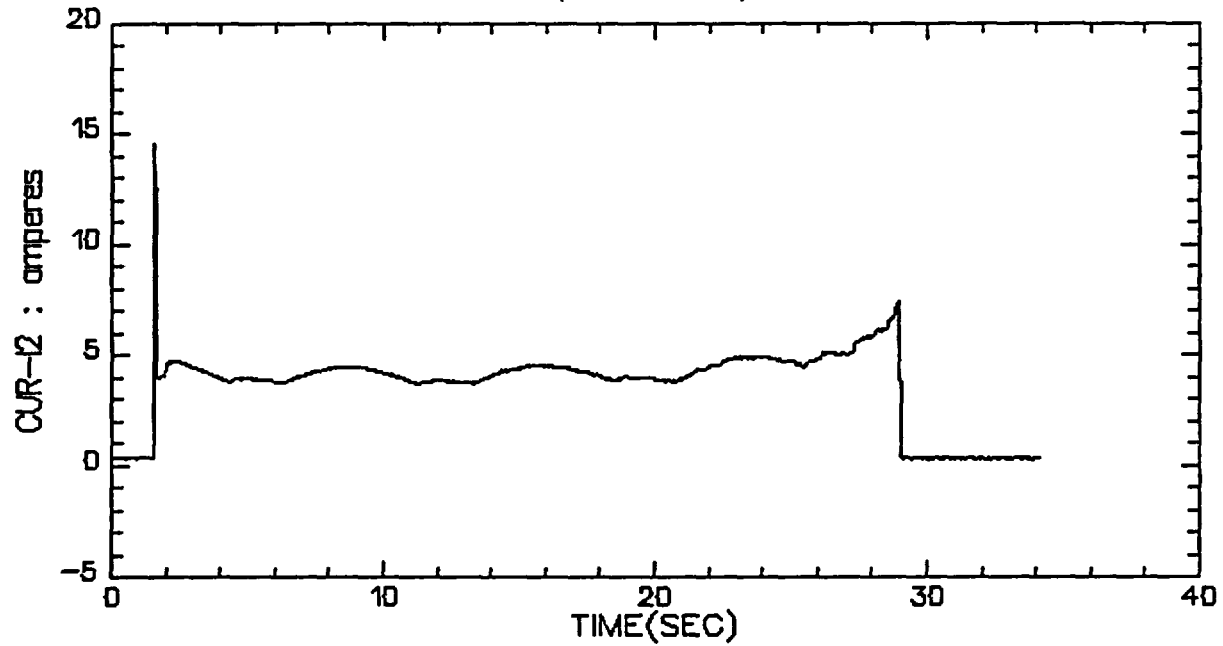

VALVE B, TEST 3, STEP 5

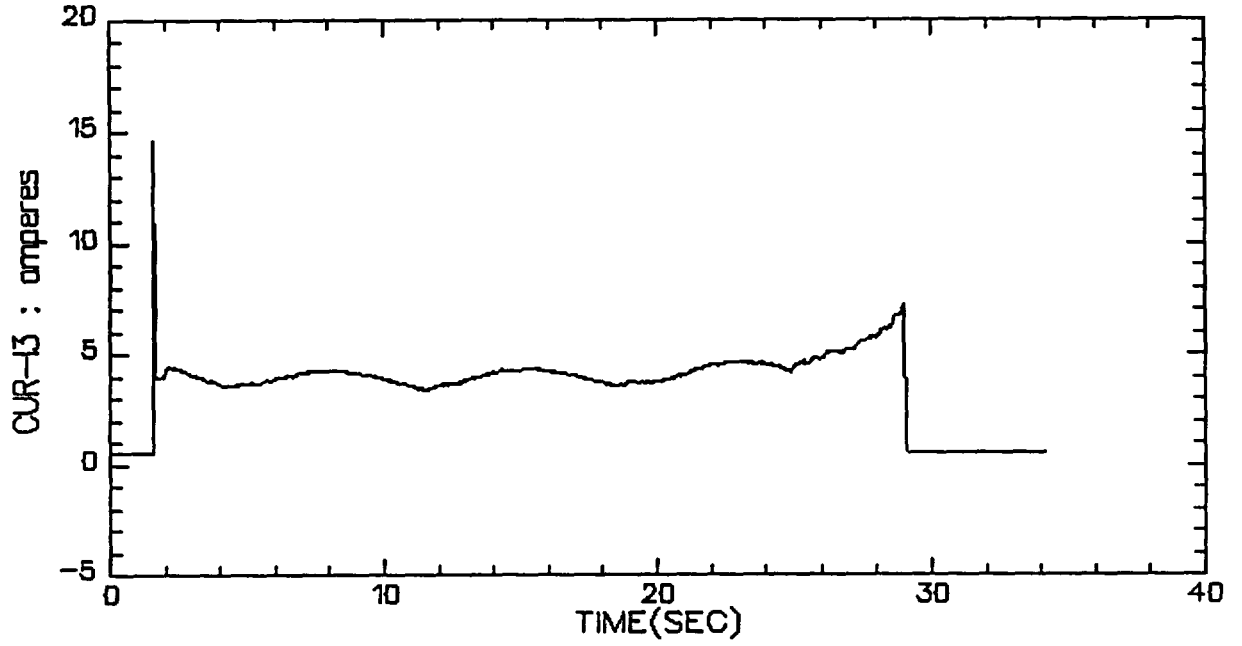

VALVE B, TEST 3, STEP 5

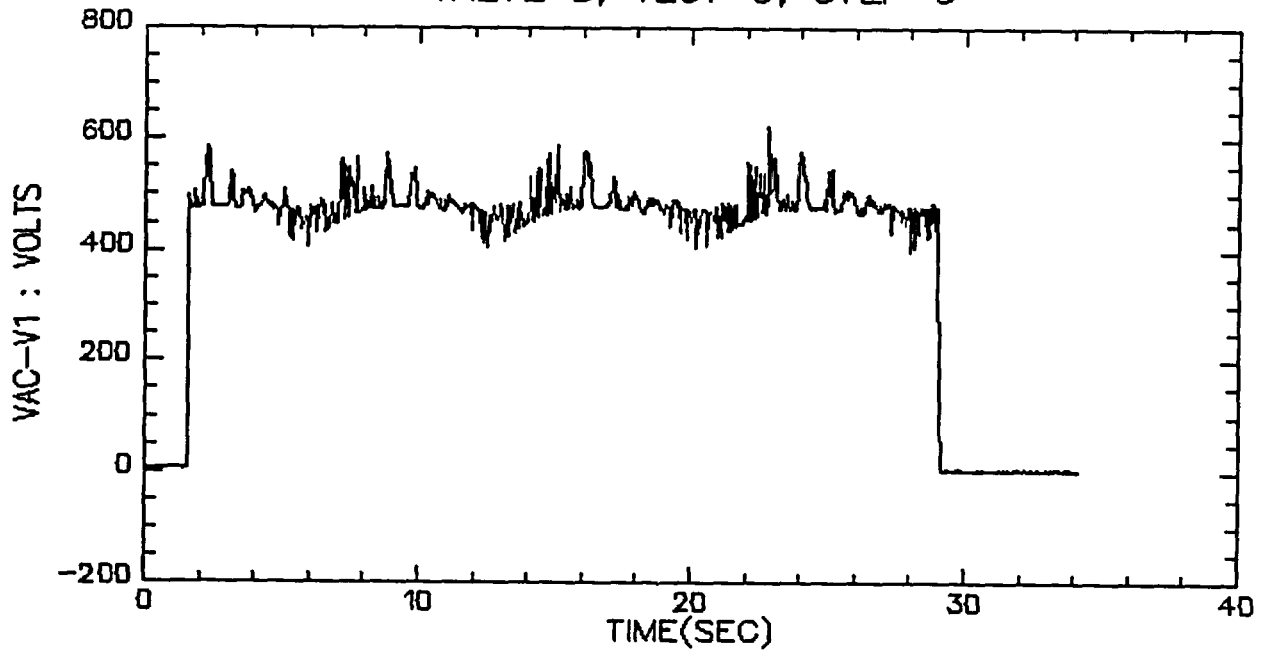

VALVE B, TEST 3, STEP 5

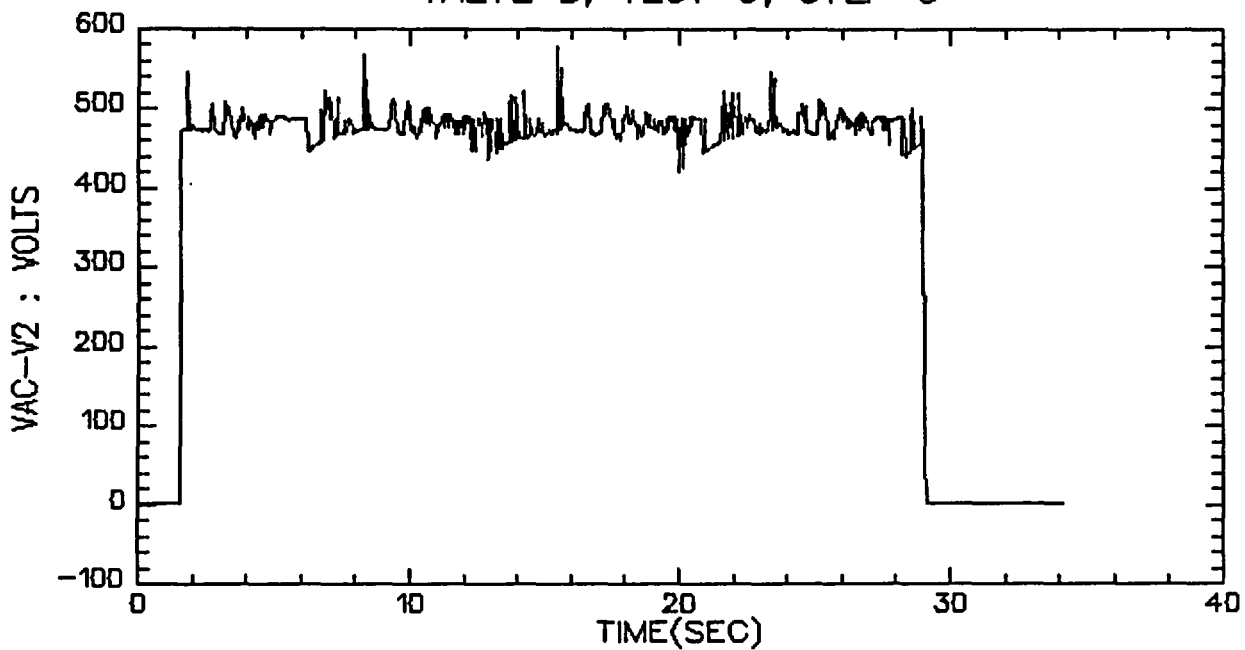

VALVE B, TEST 3, STEP 5

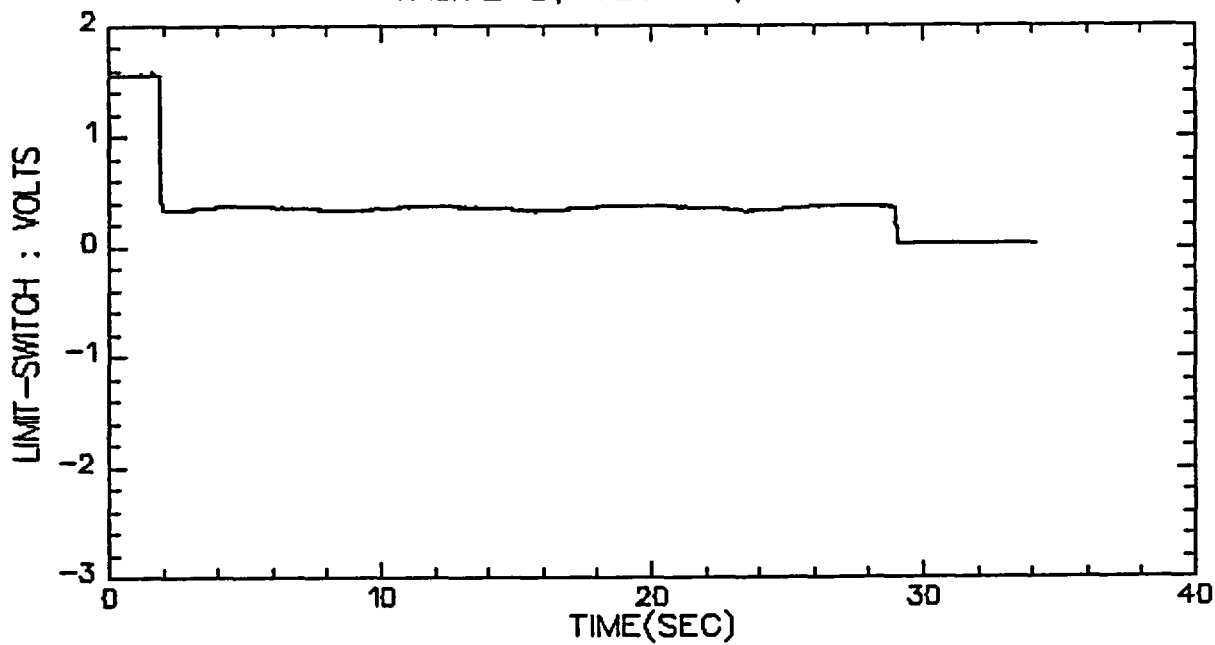

VALVE B, TEST 3, STEP 5

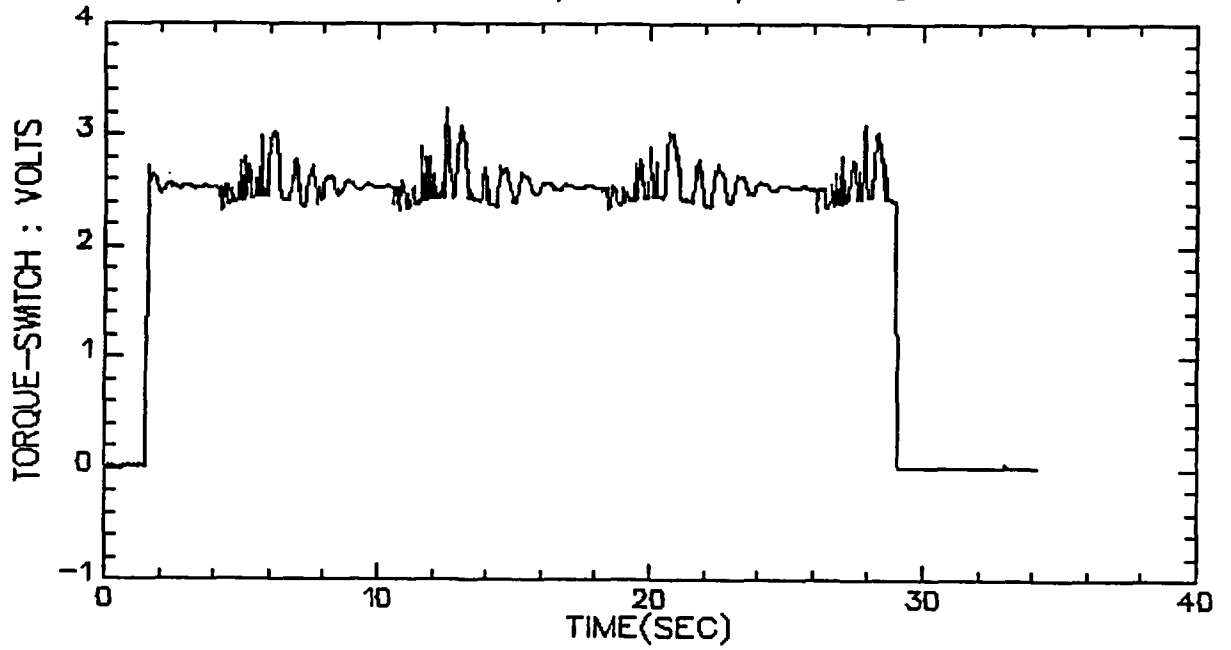

VALVE B, TEST 3, STEP 5

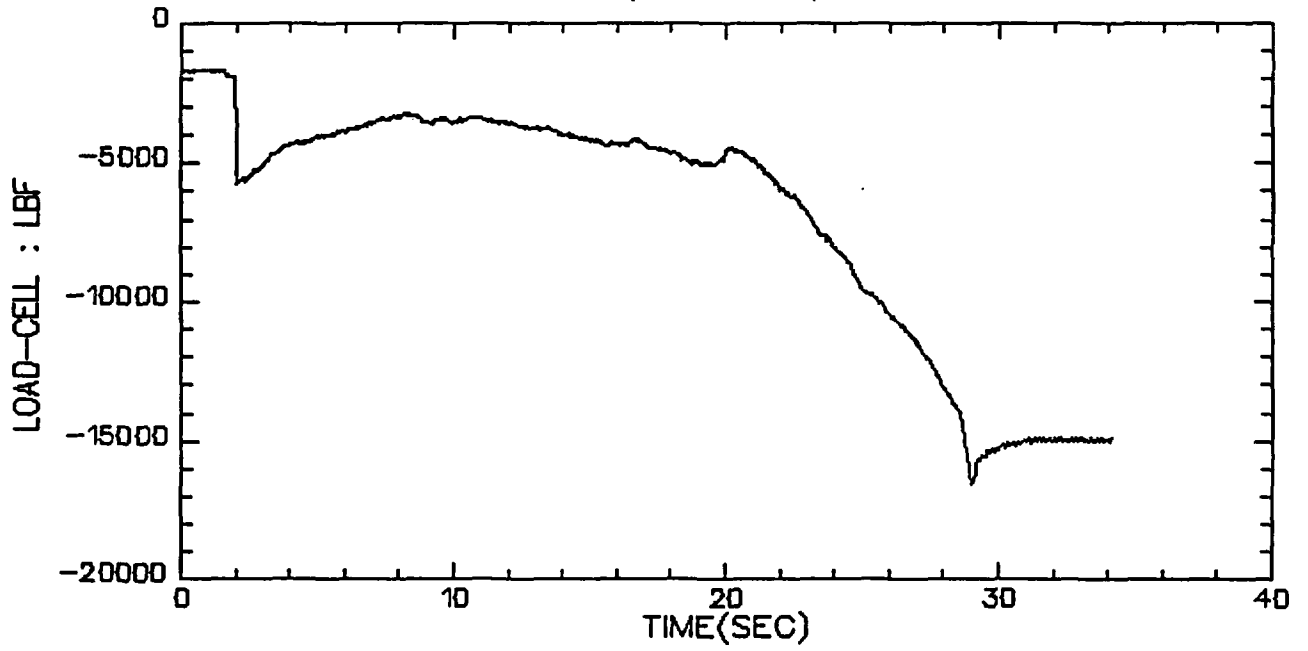

VALVE B, TEST 3, STEP 6&7

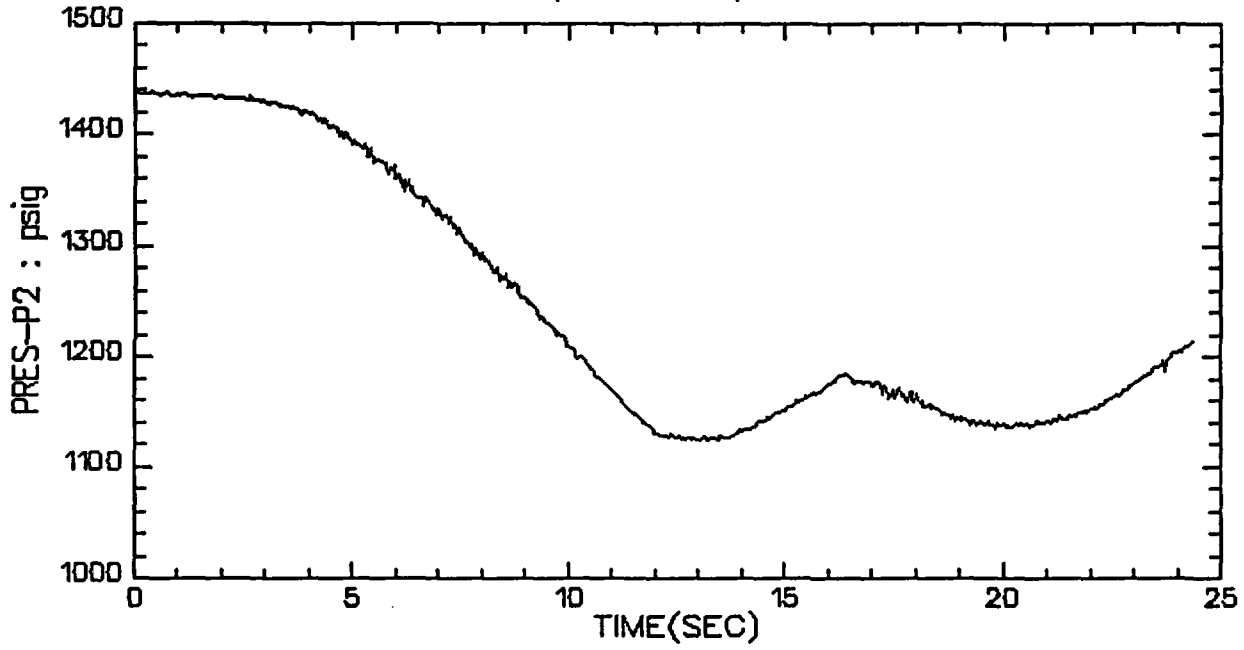

VALVE B, TEST 3, STEP 6&7

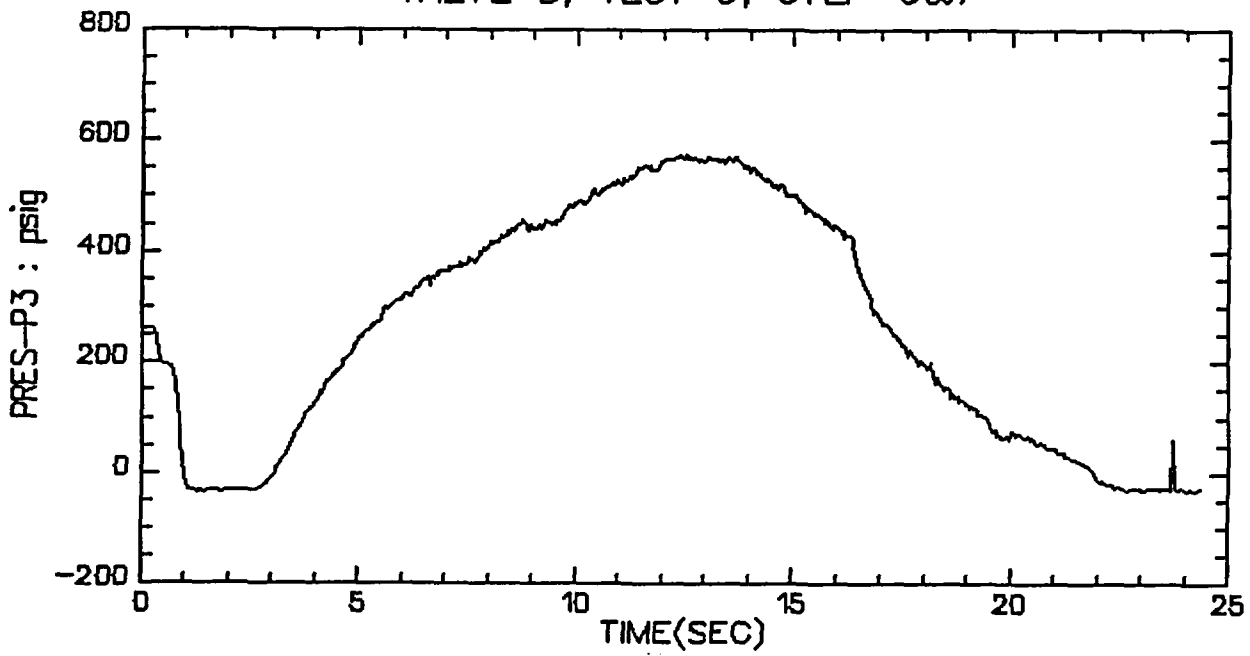

VALVE B, TEST 3, STEP 6&7

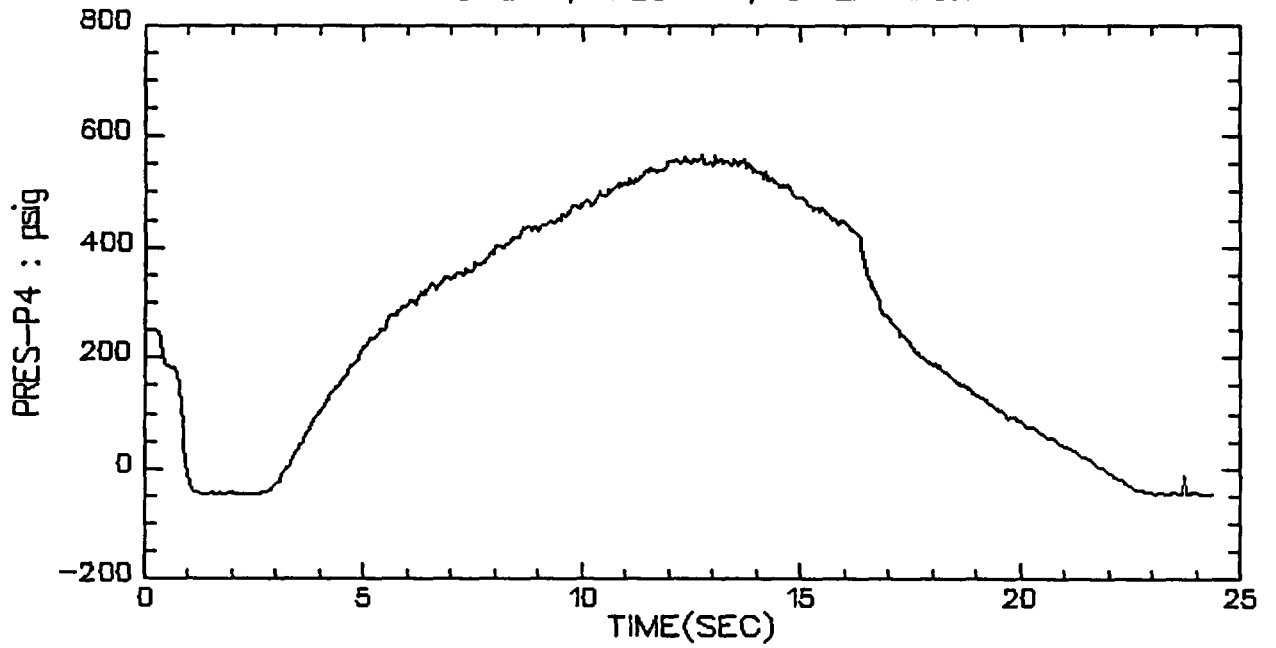

VALVE B, TEST 3, STEP 6&7

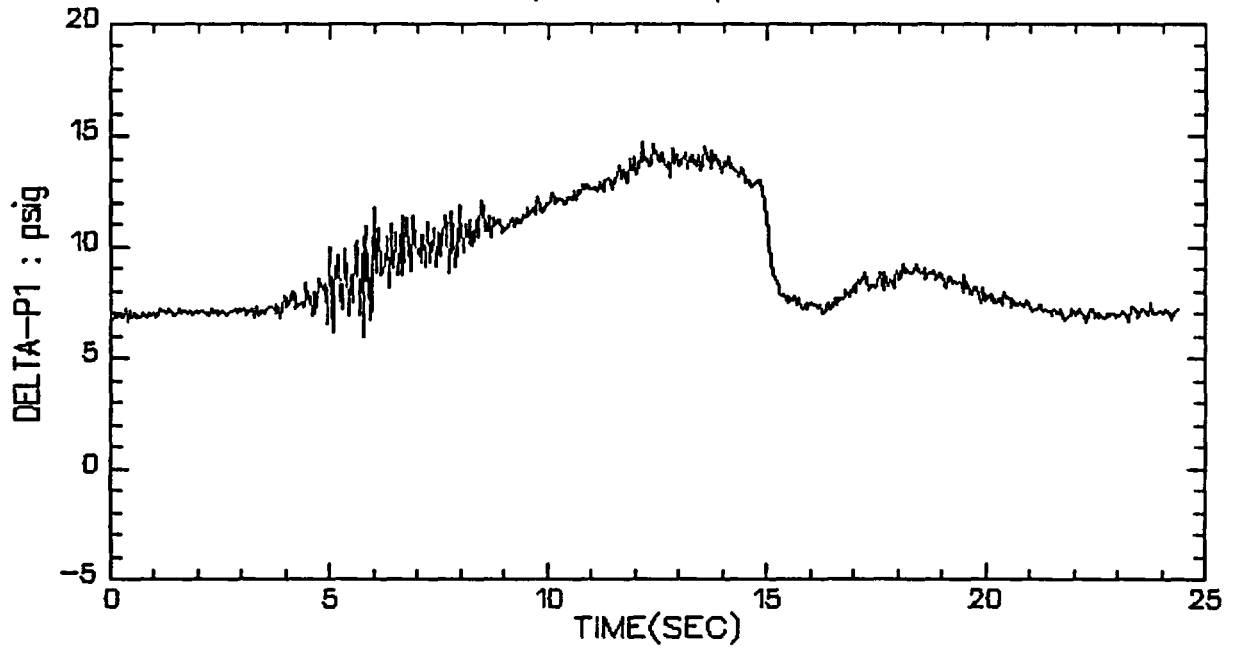

VALVE B, TEST 3, STEP 6&7

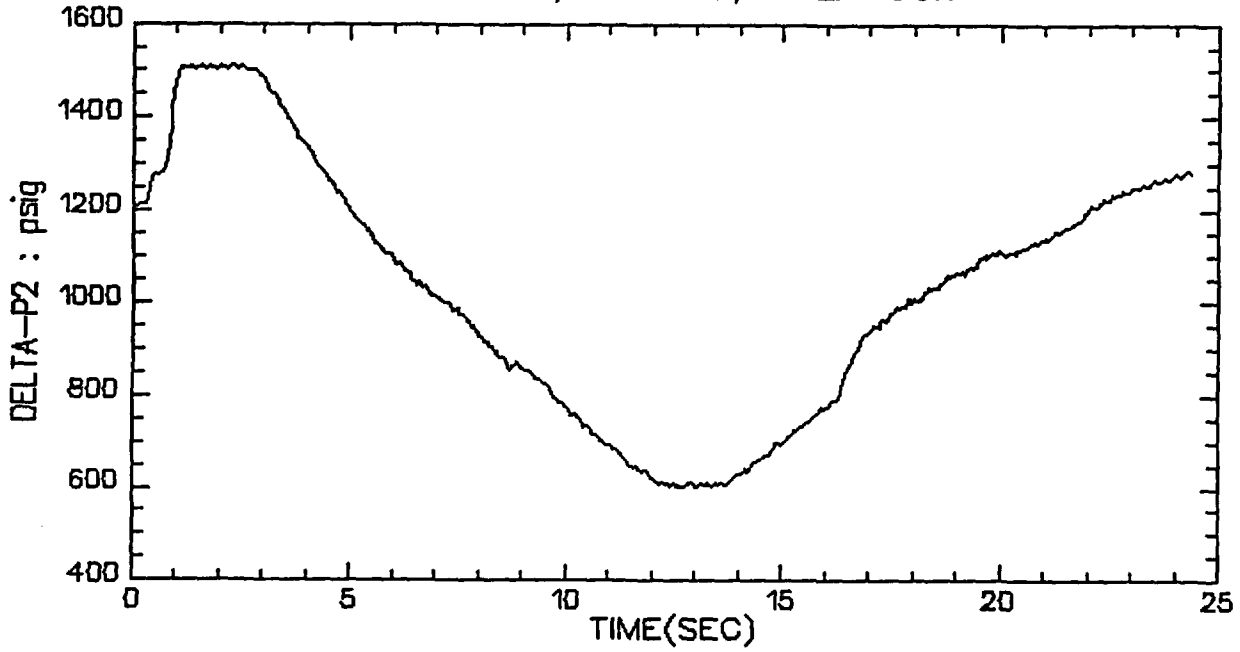

VALVE B, TEST 3, STEP 6&7

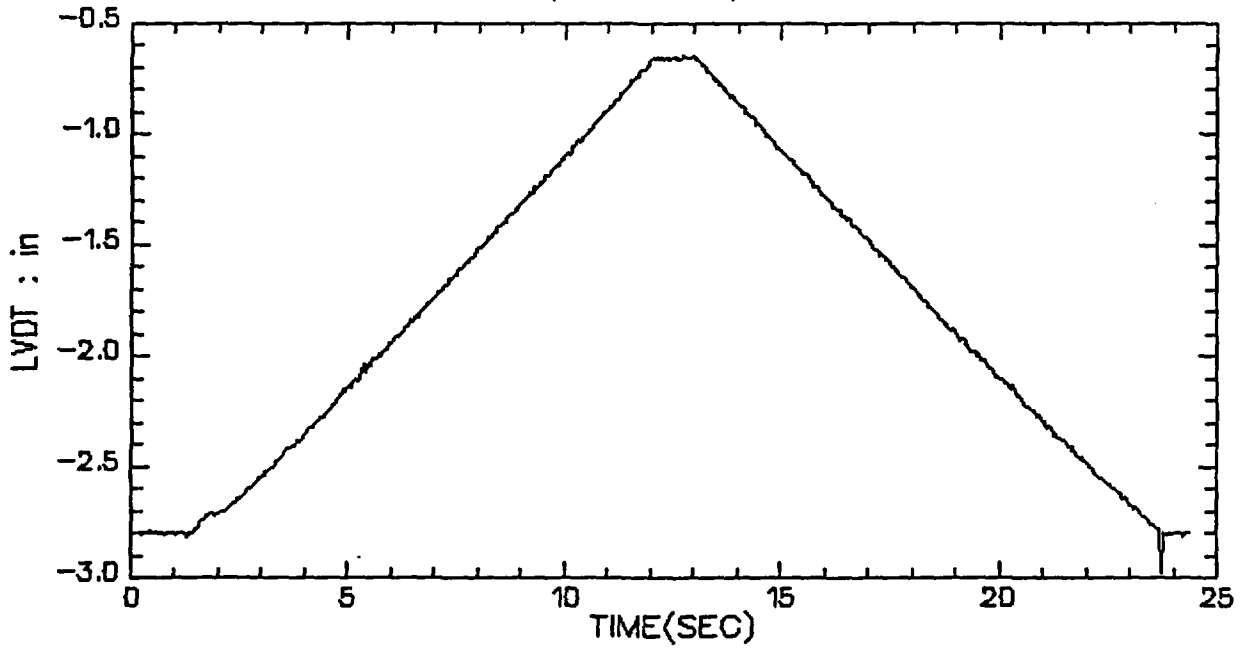

VALVE B, TEST 3, STEP 6&7

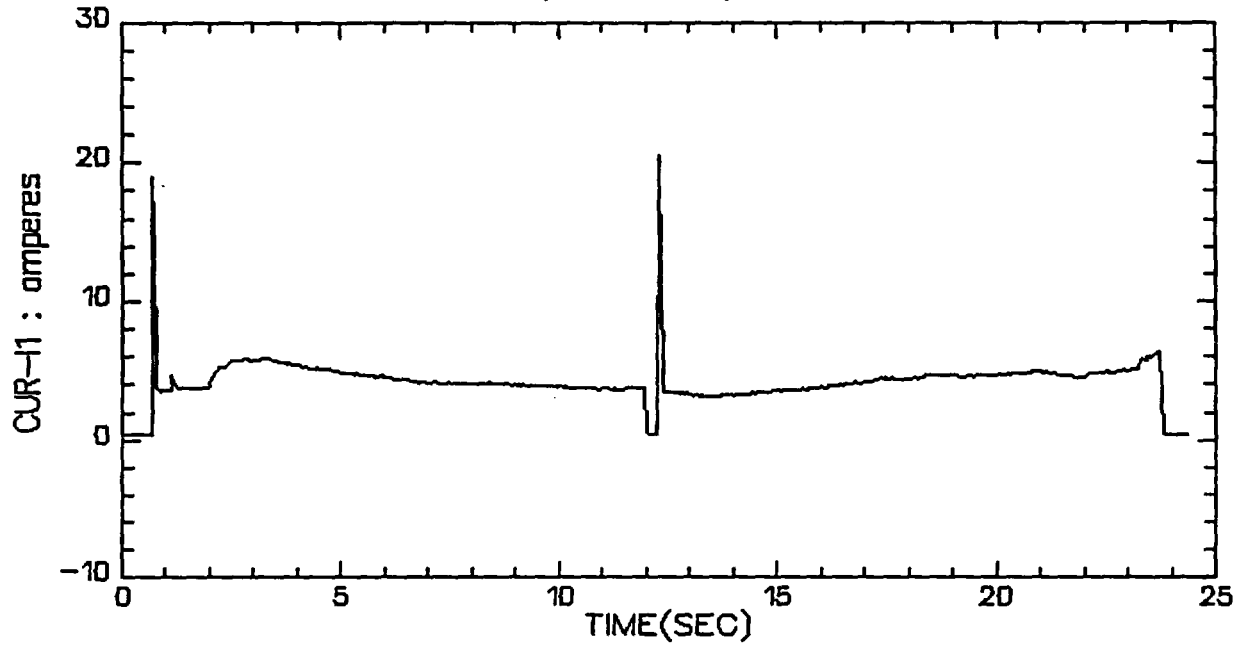

VALVE B, TEST 3, STEP 6&7

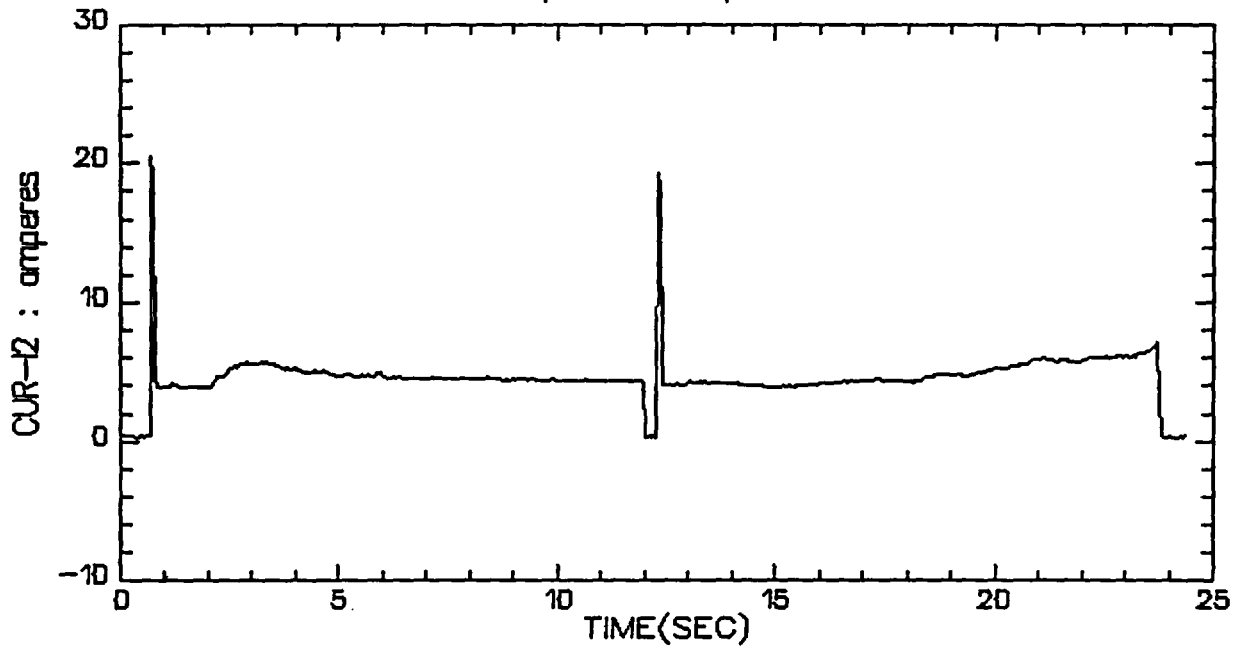

VALVE B, TEST 3, STEP 6&7

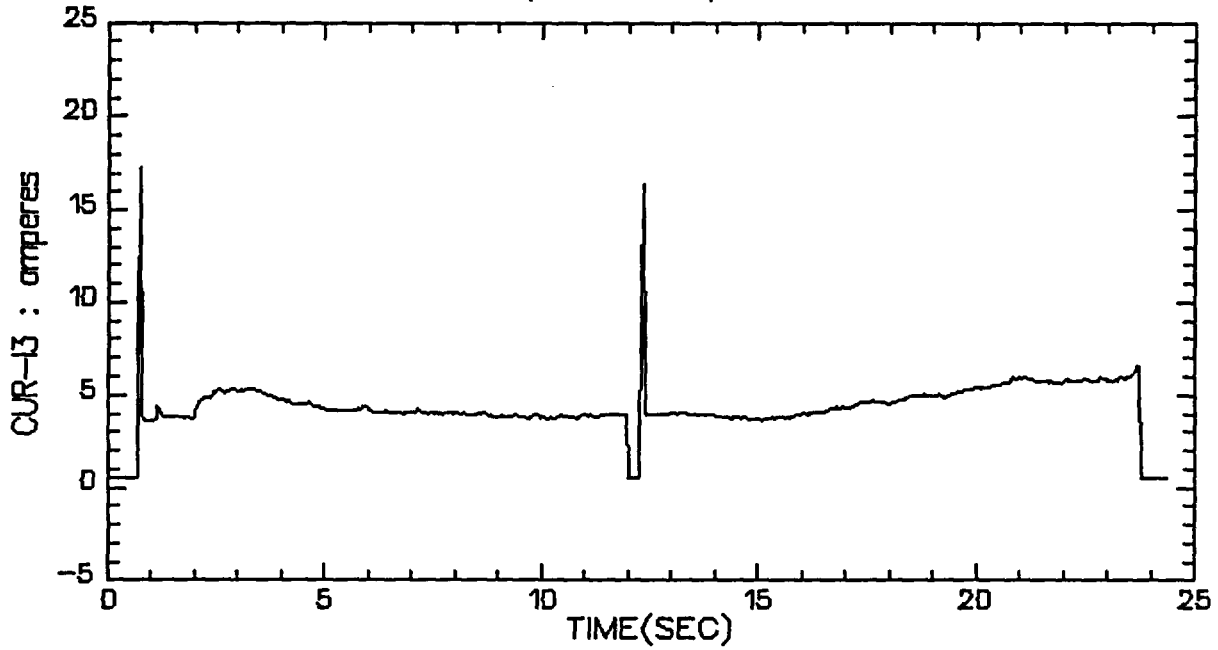

VALVE B, TEST 3, STEP 6&7

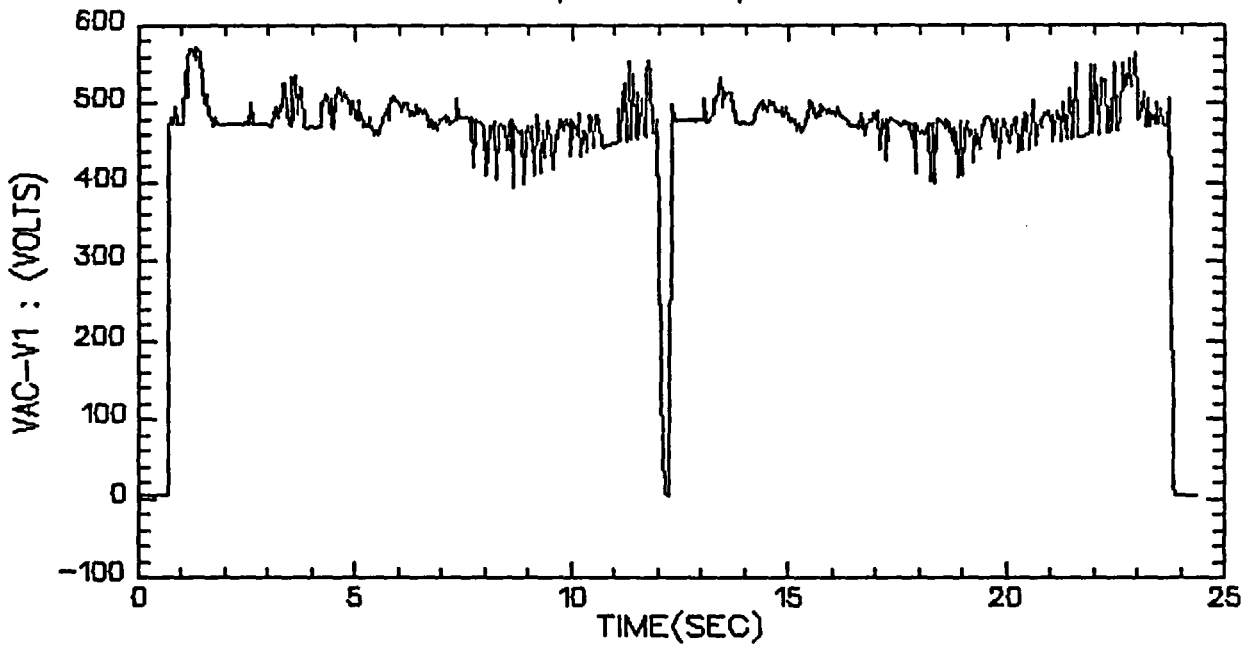

VALVE B, TEST 3, STEP 6&7

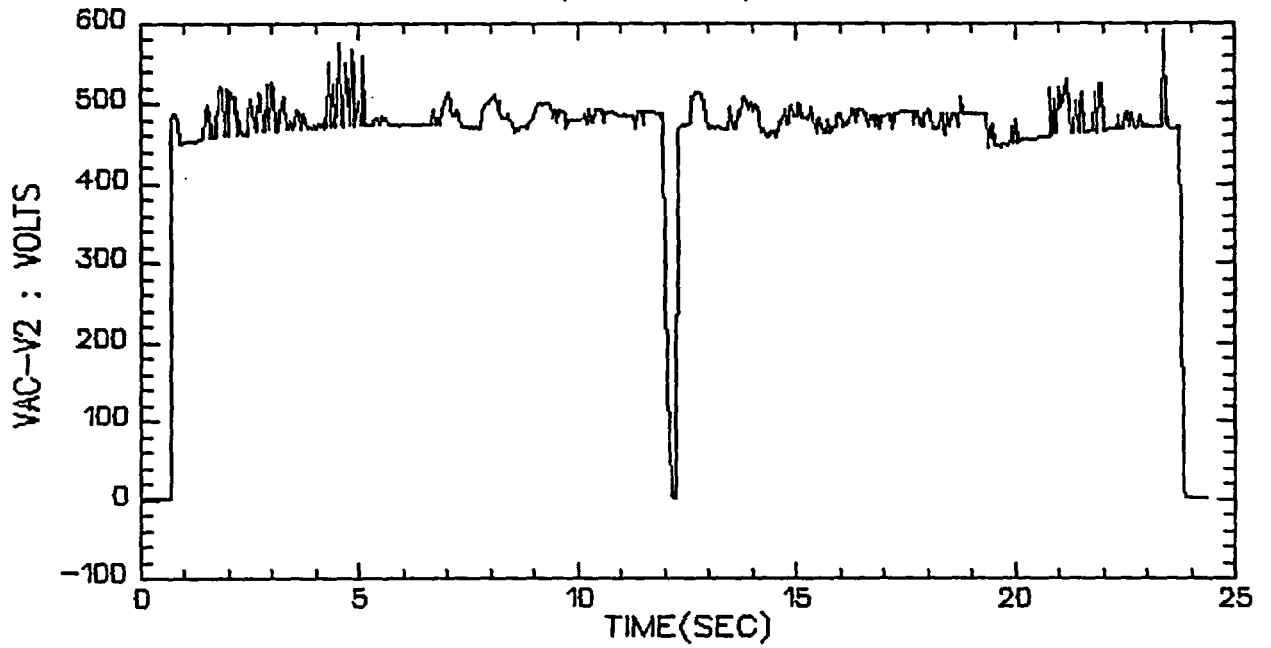

VALVE B, TEST 3, STEP 6&7

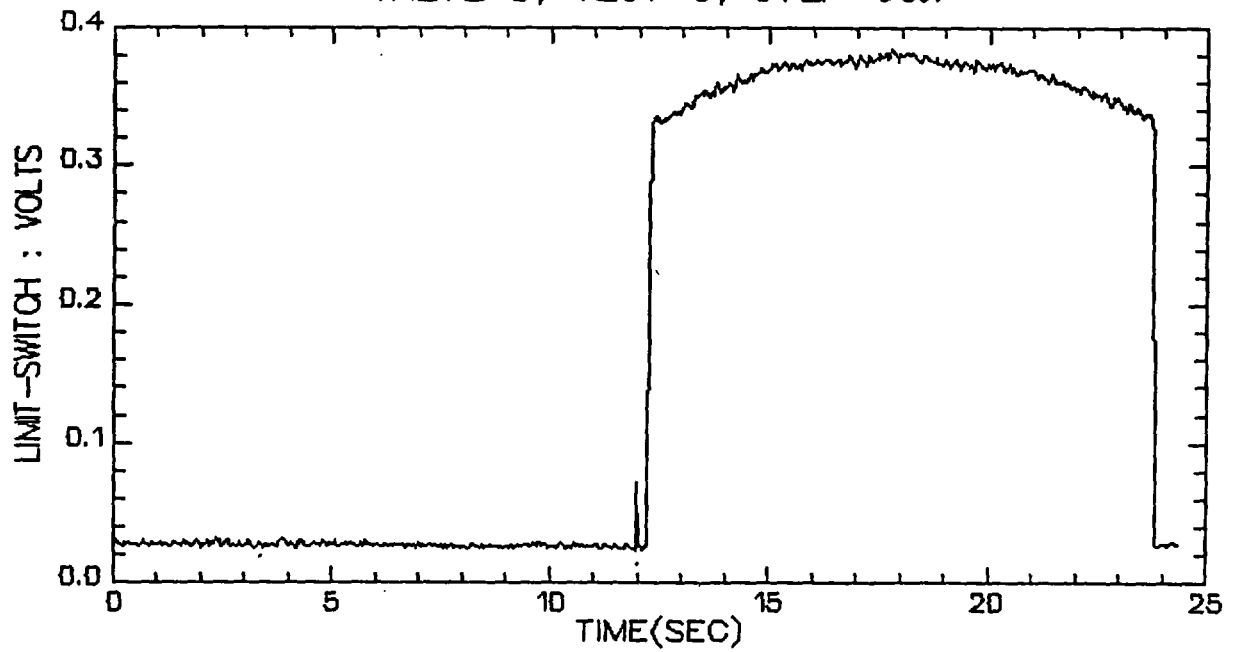

VALVE B, TEST 3, STEP 6&7

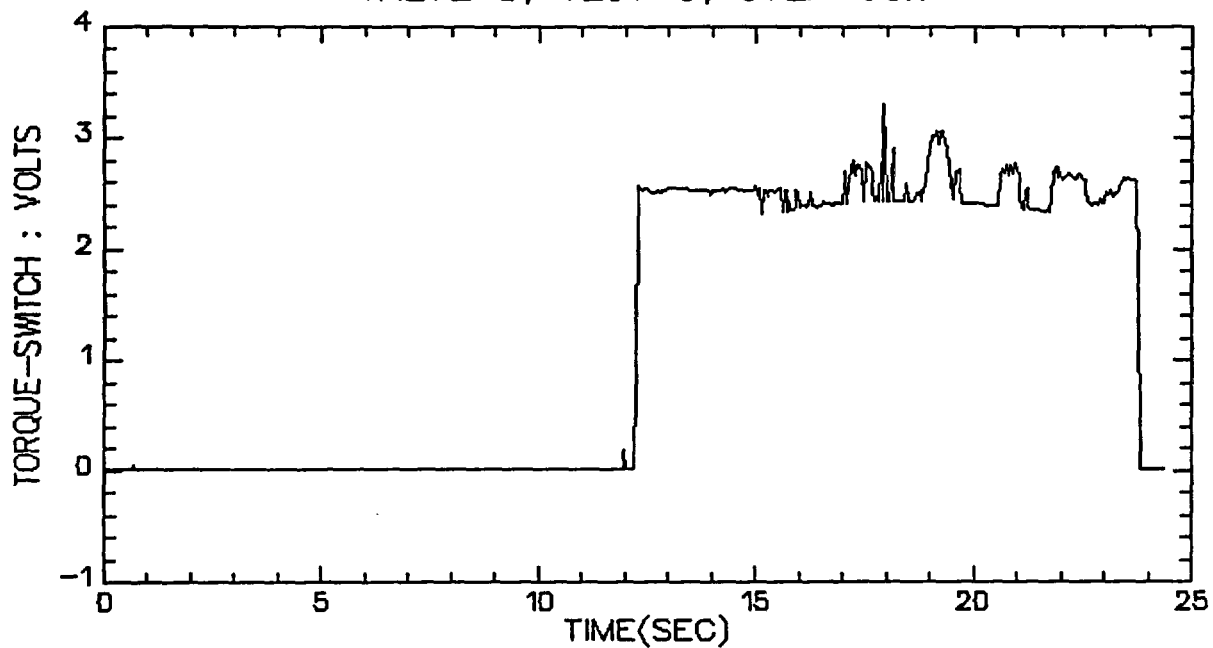

VALVE B, TEST 3, STEP 6&7

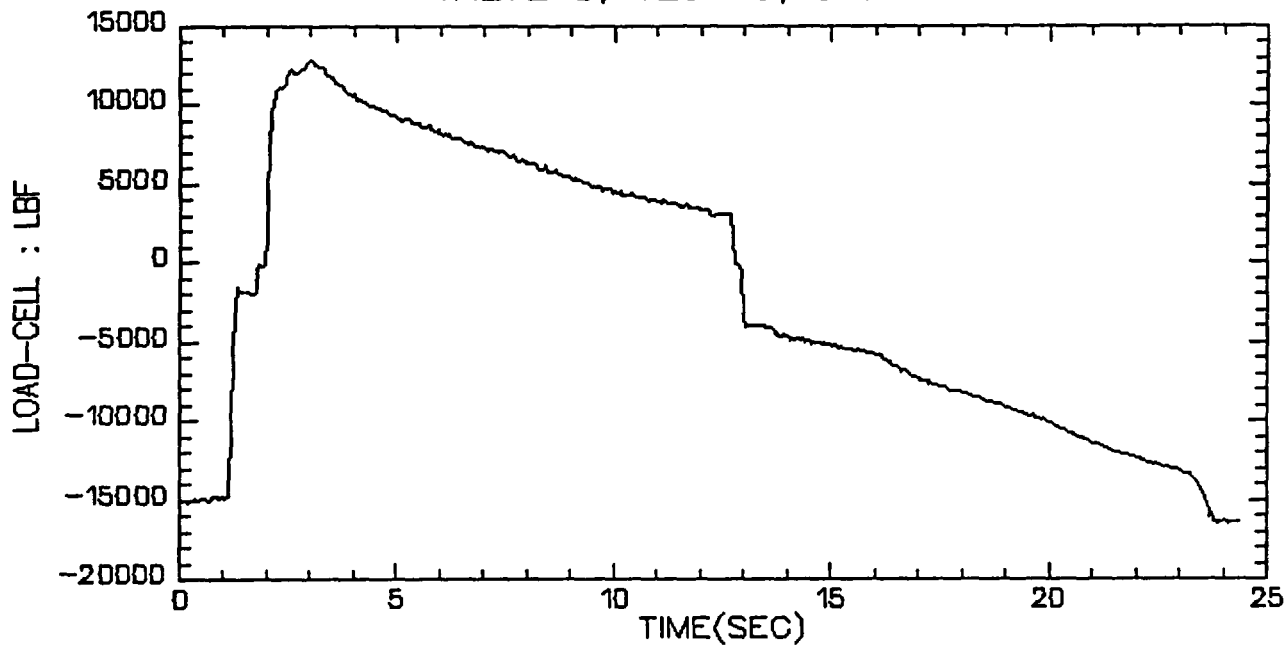

VALVE B, TEST 3, STEP 8&9

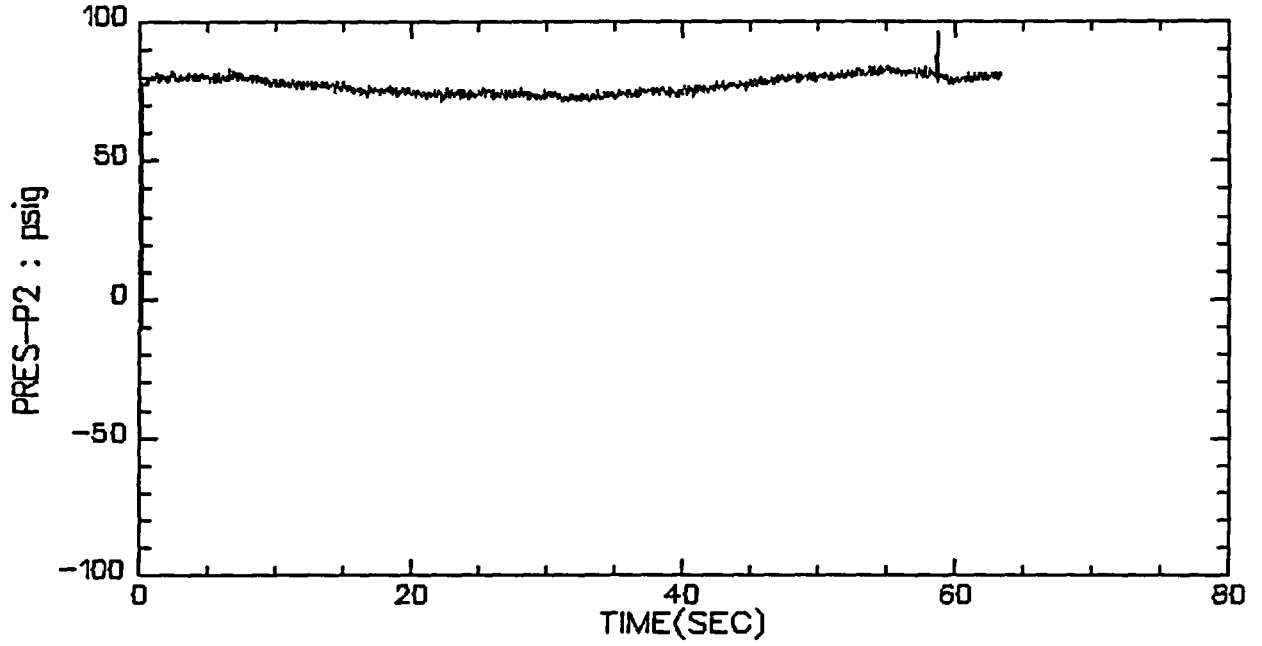

VALVE B, TEST 3, STEP 8&9

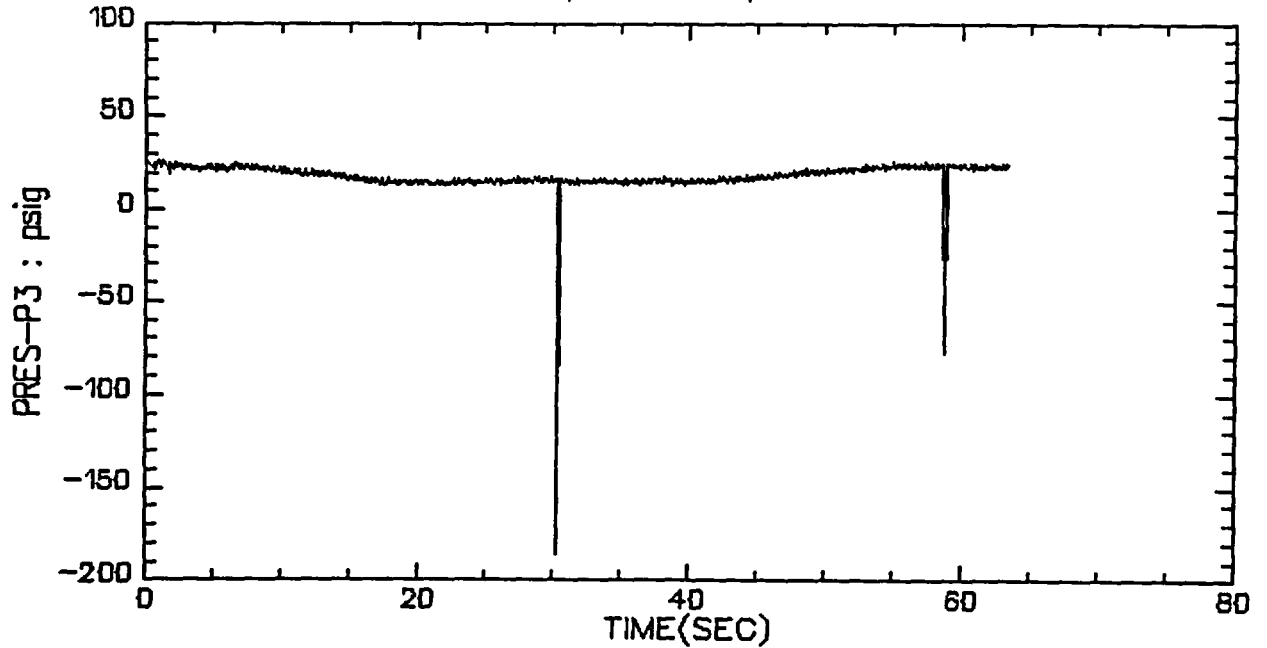

VALVE B, TEST 3, STEP 8&9

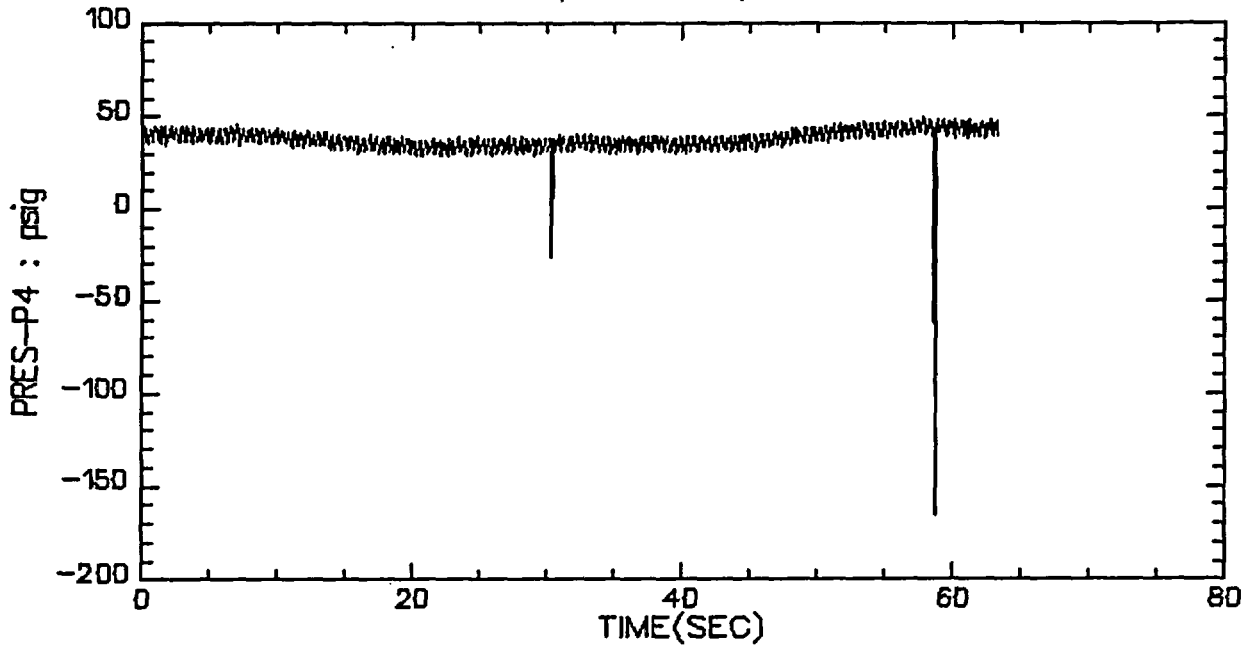

VALVE B, TEST 3, STEP 8&9

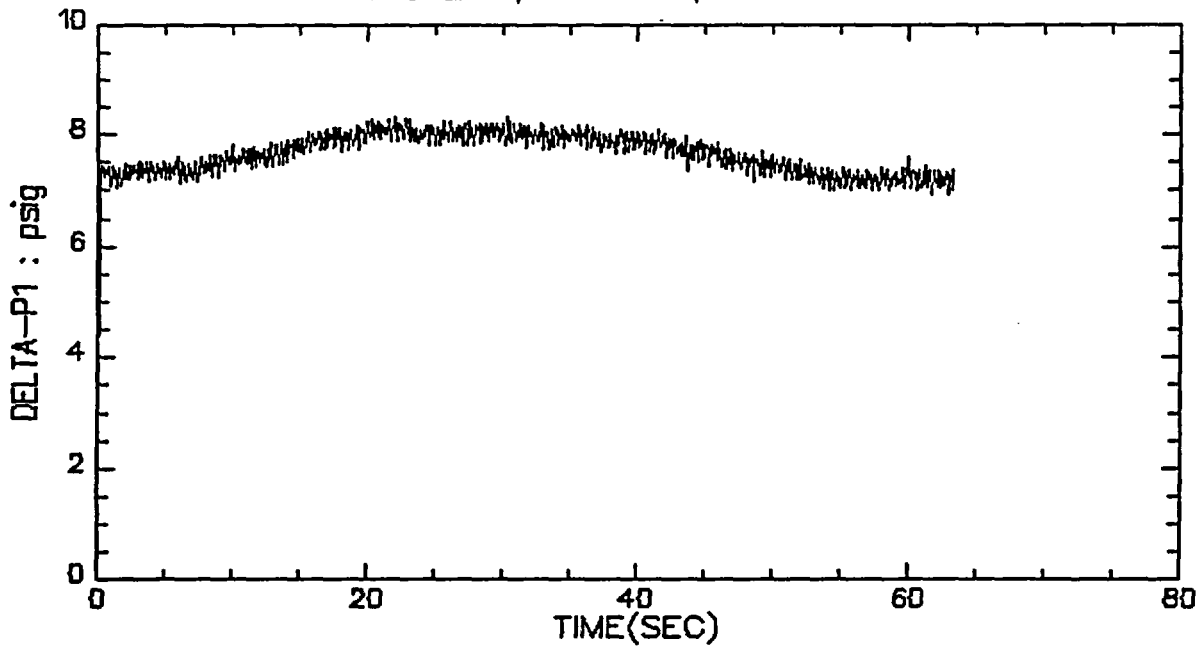

VALVE B, TEST 3, STEP 8&9

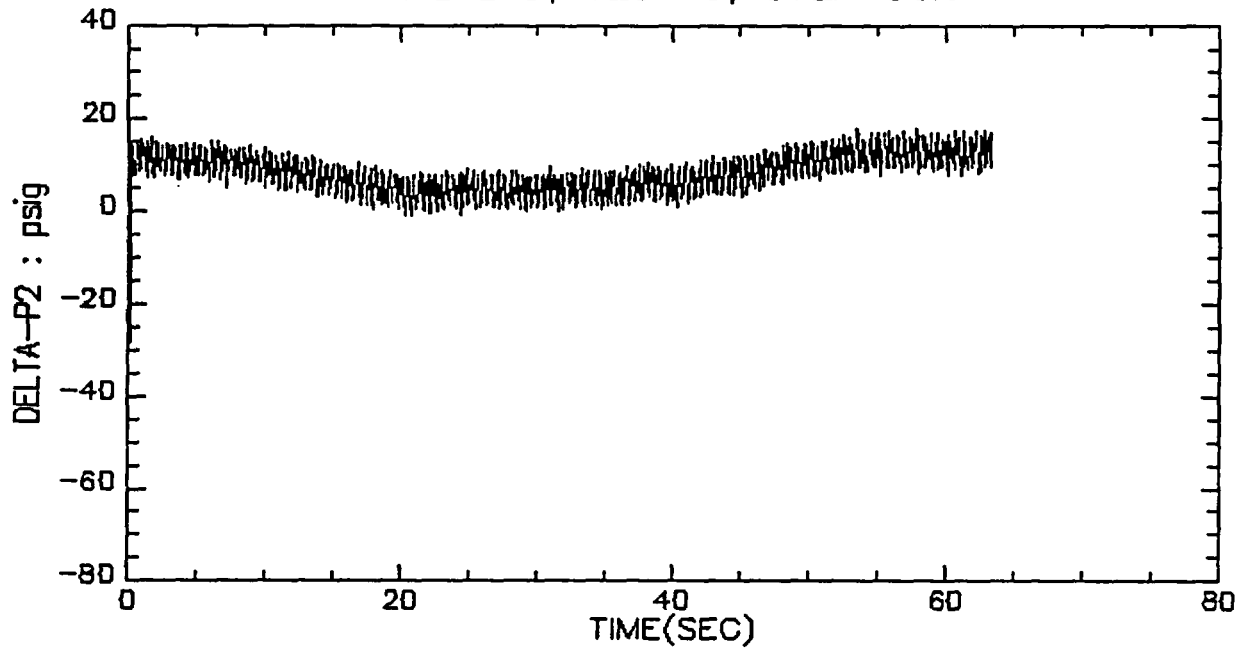

VALVE B, TEST 3, STEP 8&9

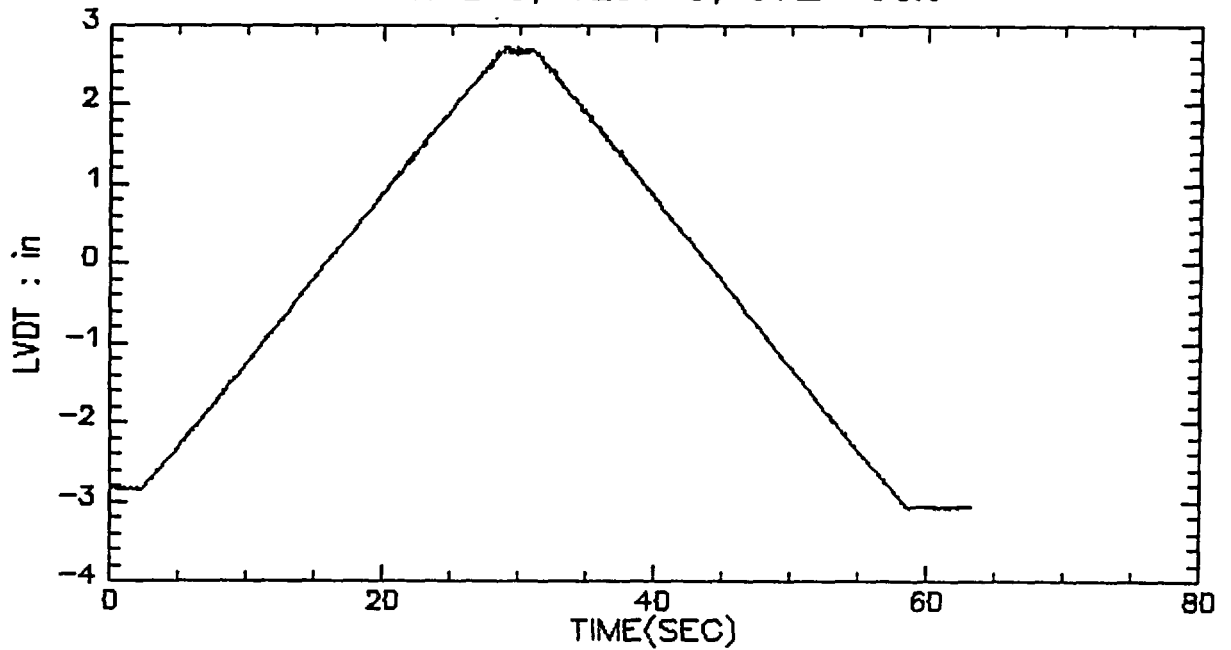

VALVE B, TEST 3, STEP 8&9

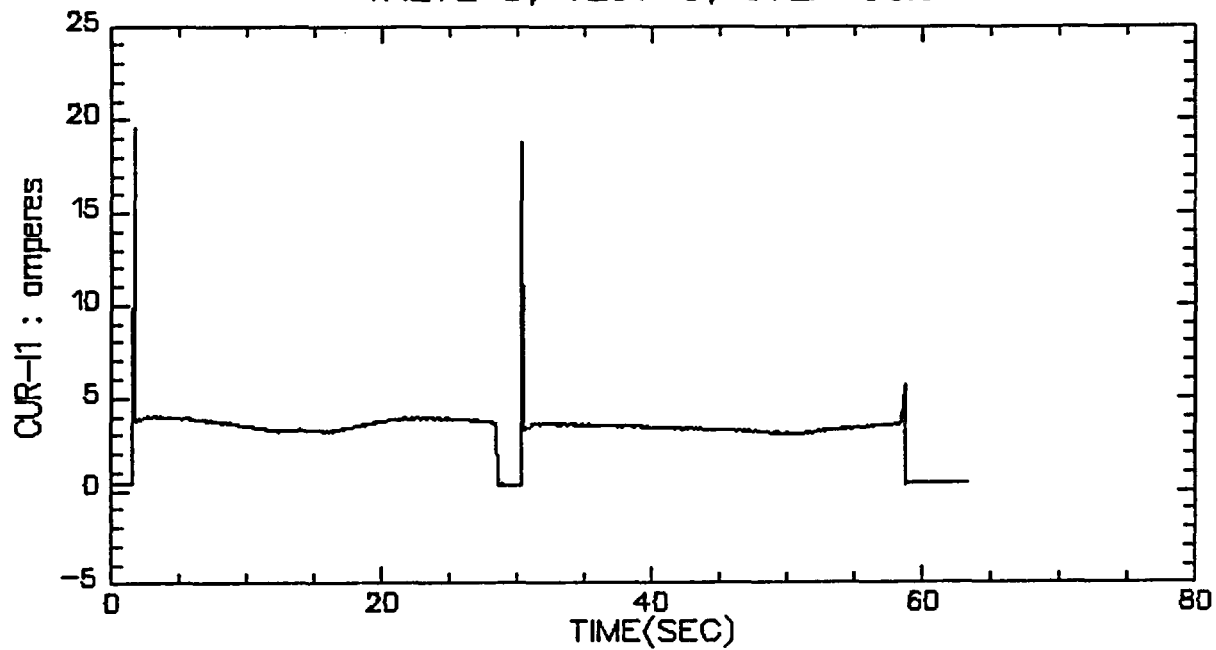

VALVE B, TEST 3, STEP 8&9

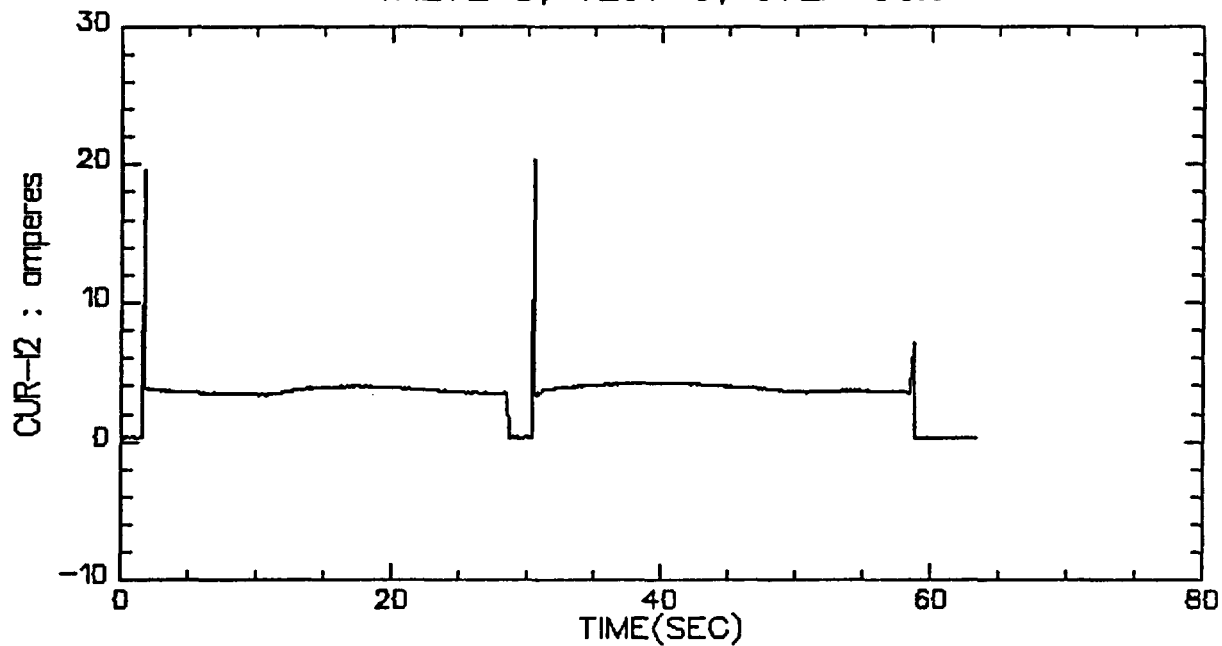

VALVE B, TEST 3, STEP 8&9

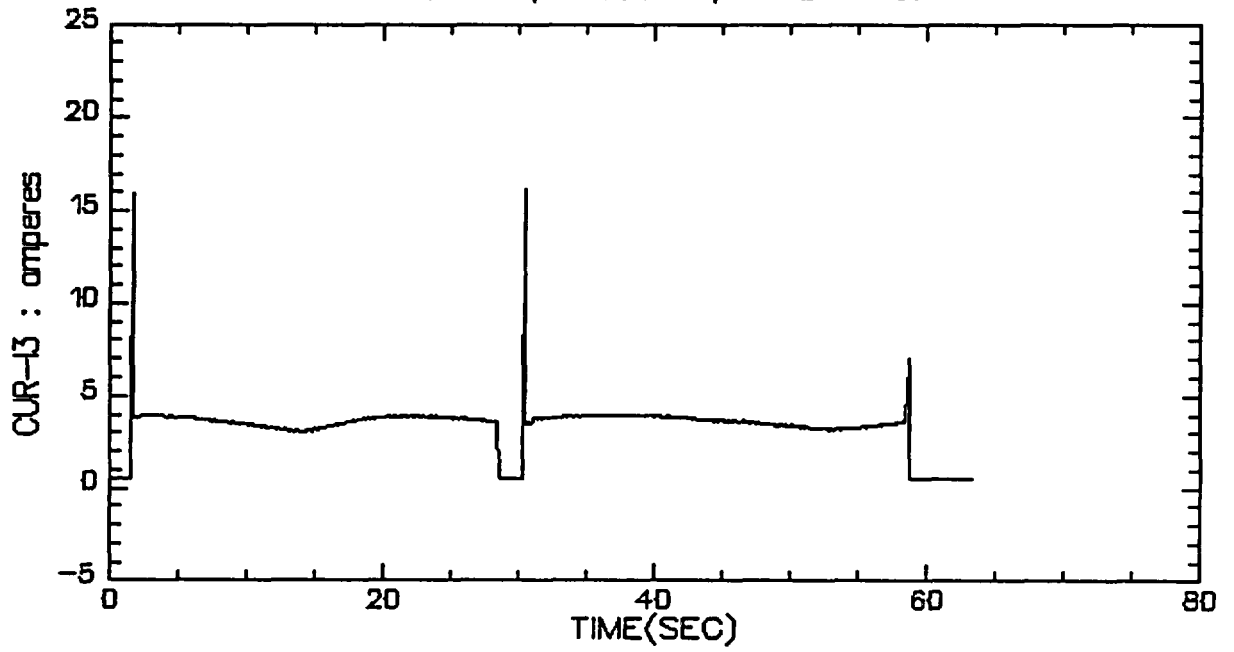

VALVE B, TEST 3, STEP 8&9

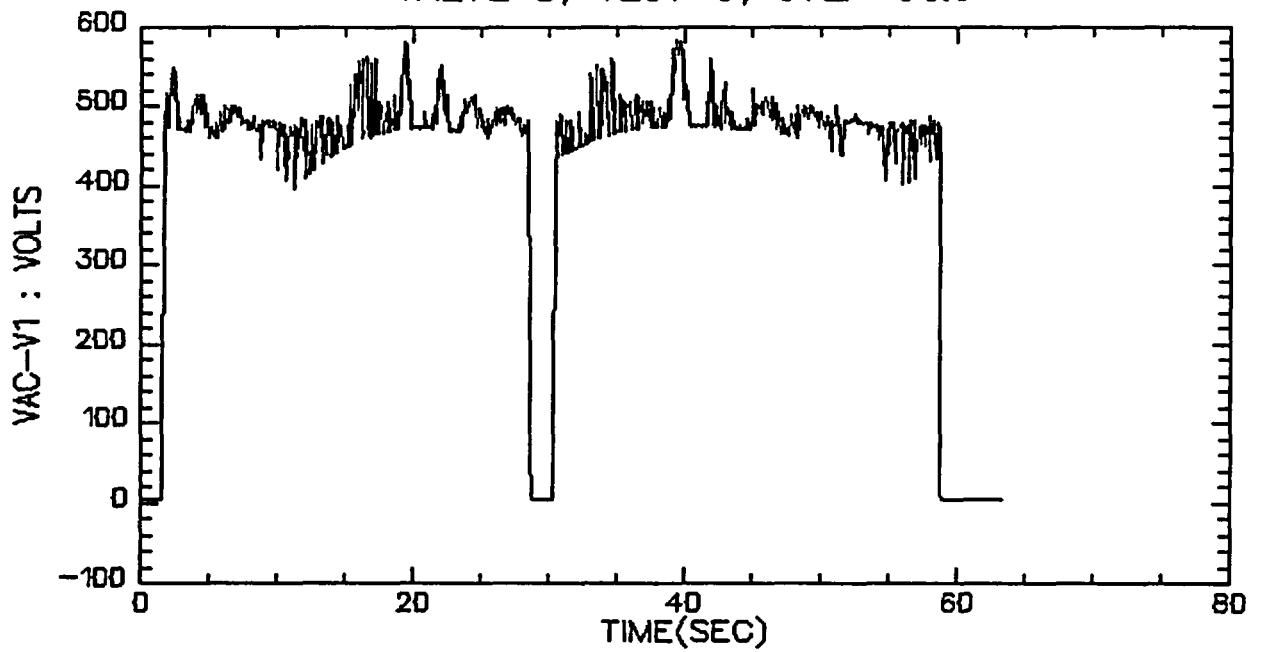

VALVE B, TEST 3, STEP 8&9

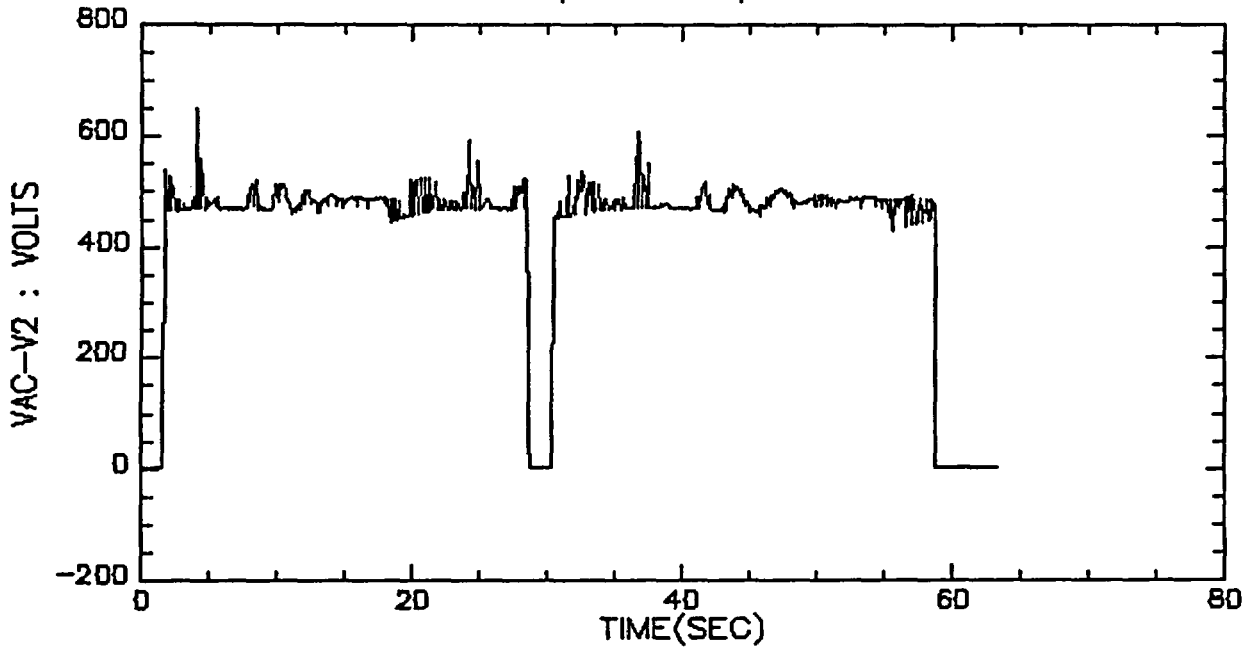

VALVE B, TEST 3, STEP 8&9

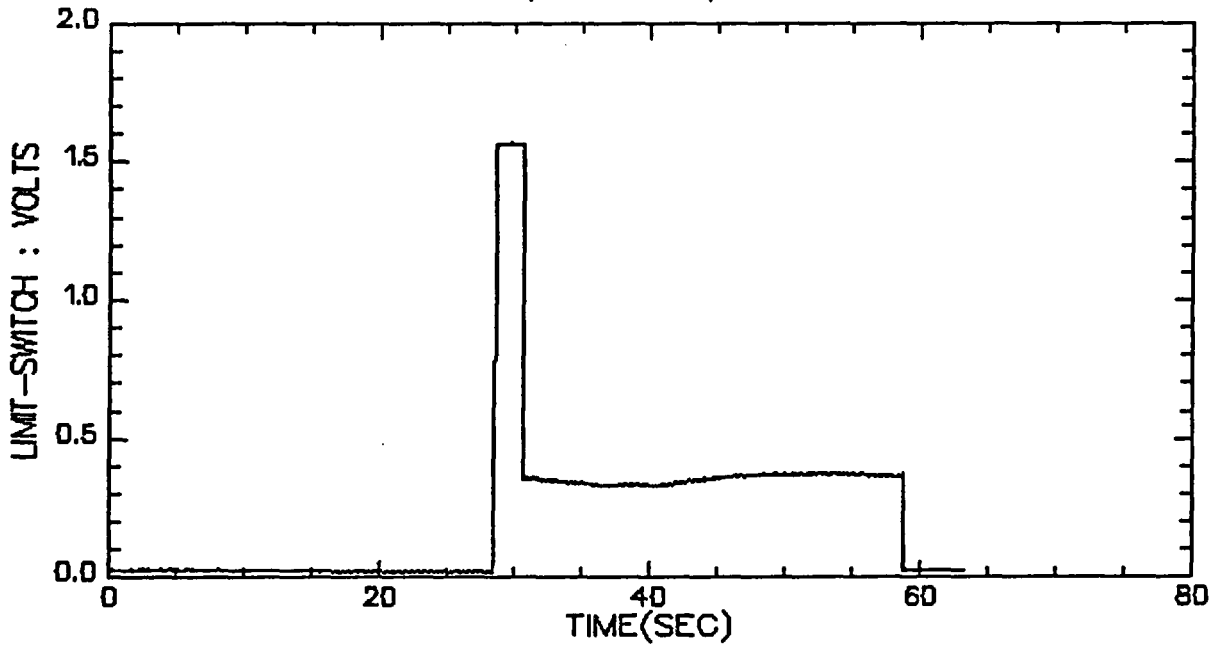

VALVE B, TEST 3, STEP 8&9

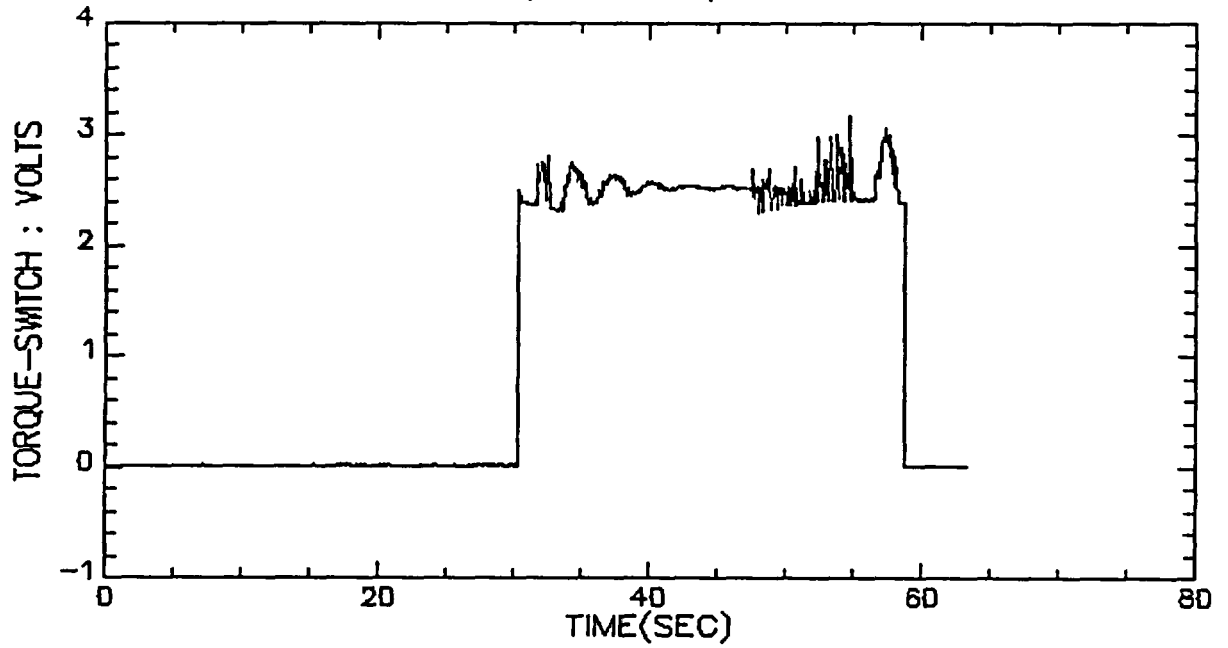

VALVE B, TEST 3, STEP 8&9

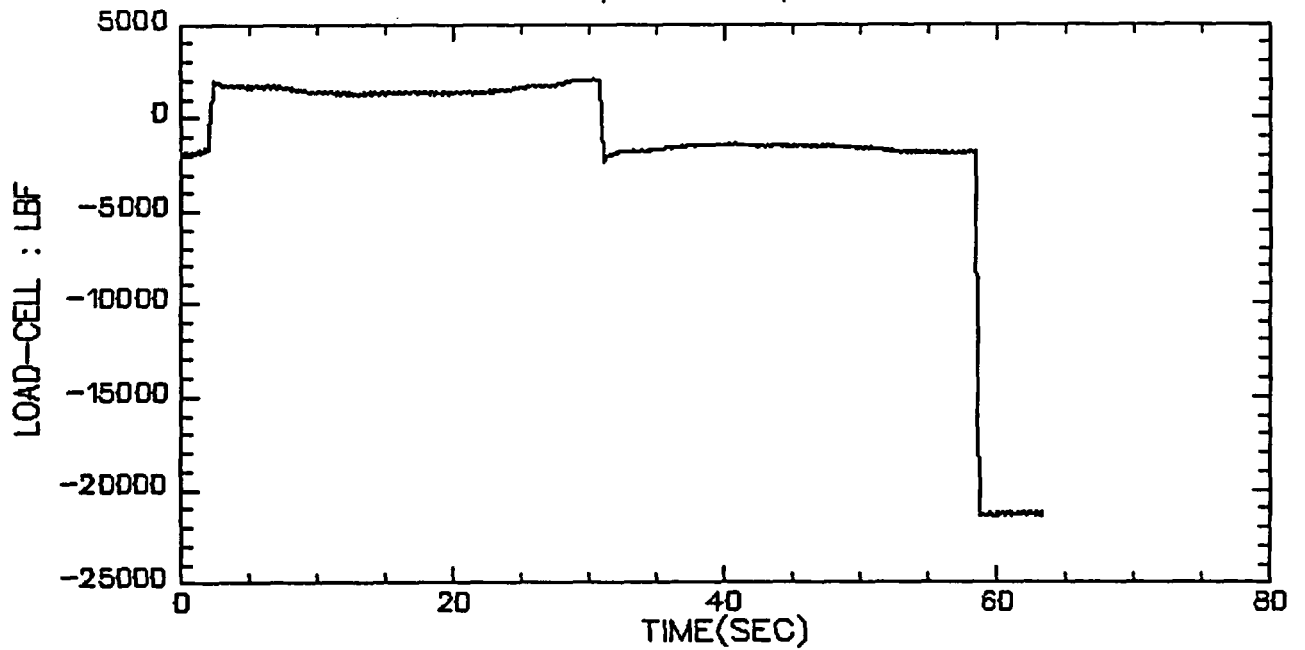

VALVE B, TEST 4, STEP 1

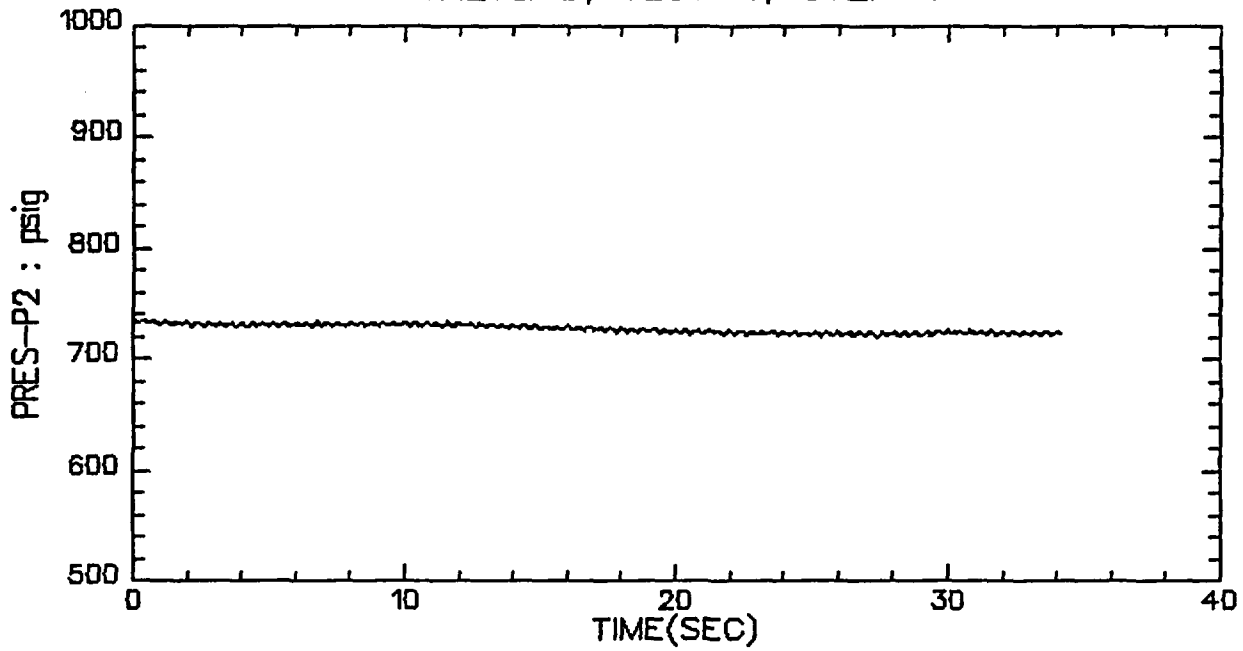

VALVE B, TEST 4, STEP 1

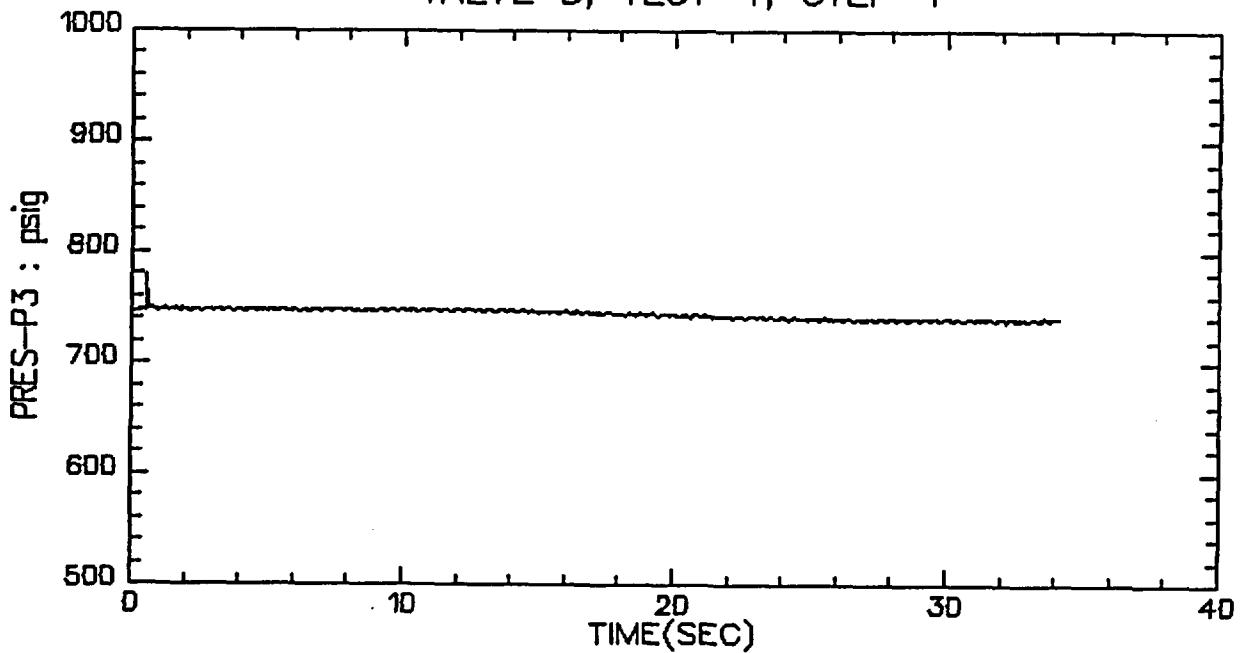

VALVE B, TEST 4, STEP 1

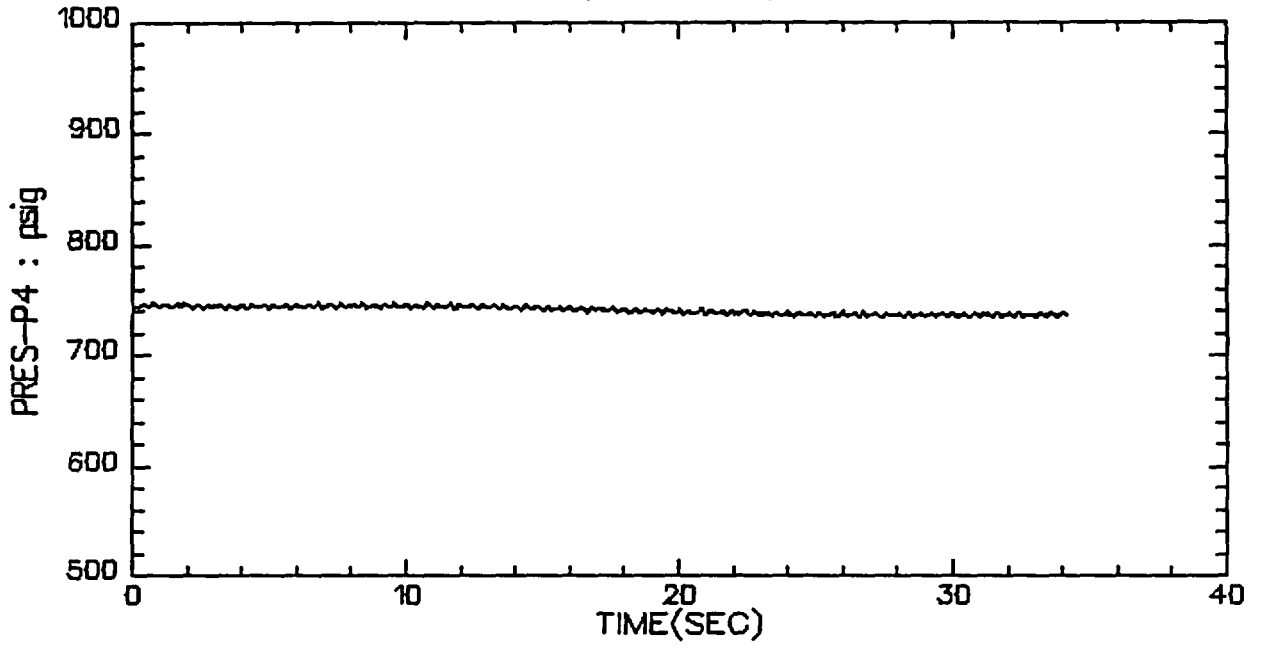

VALVE B, TEST 4, STEP 1

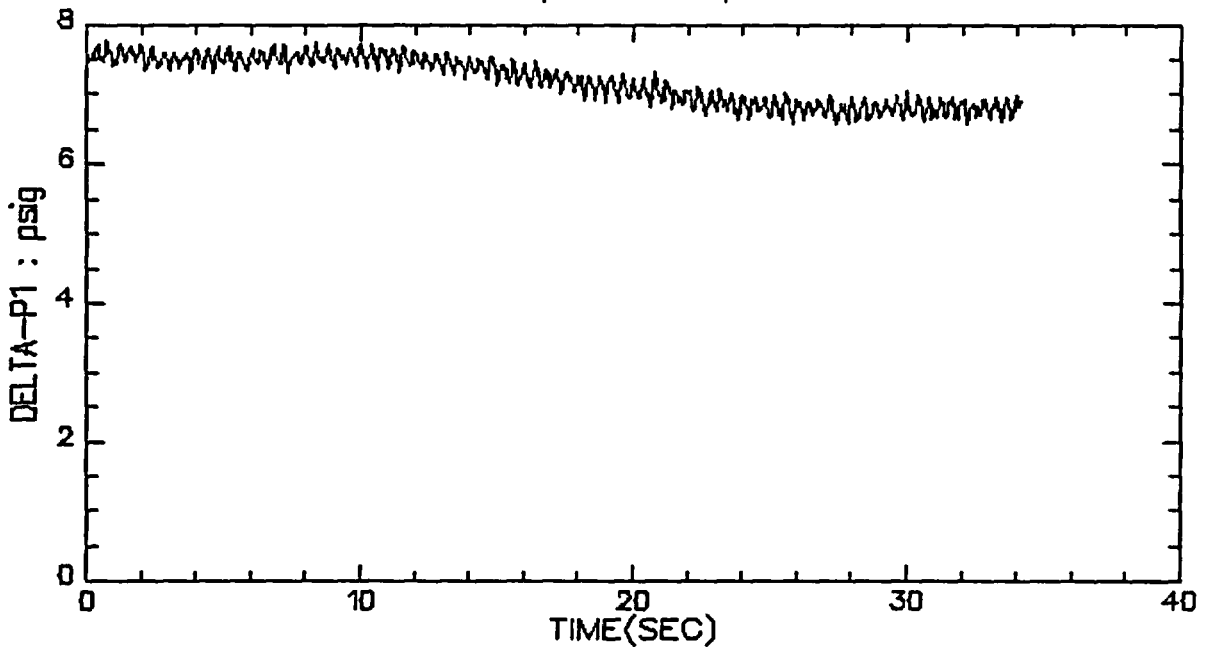

VALVE B, TEST 4, STEP 1

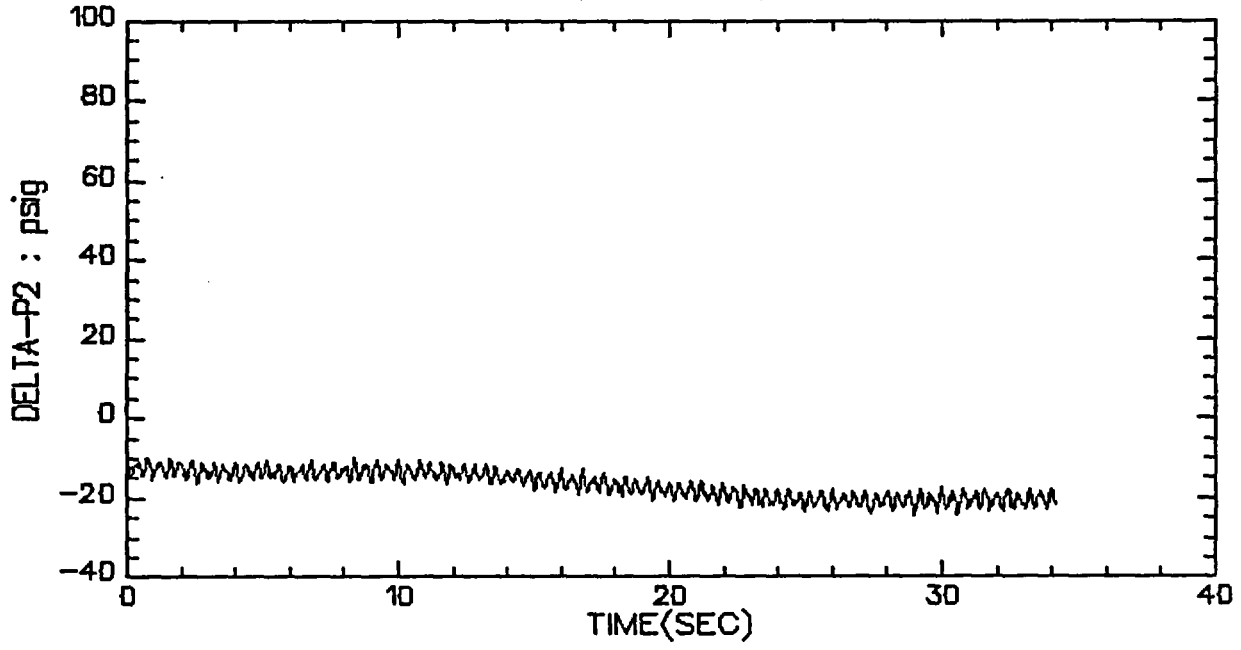

VALVE B, TEST 4, STEP 1

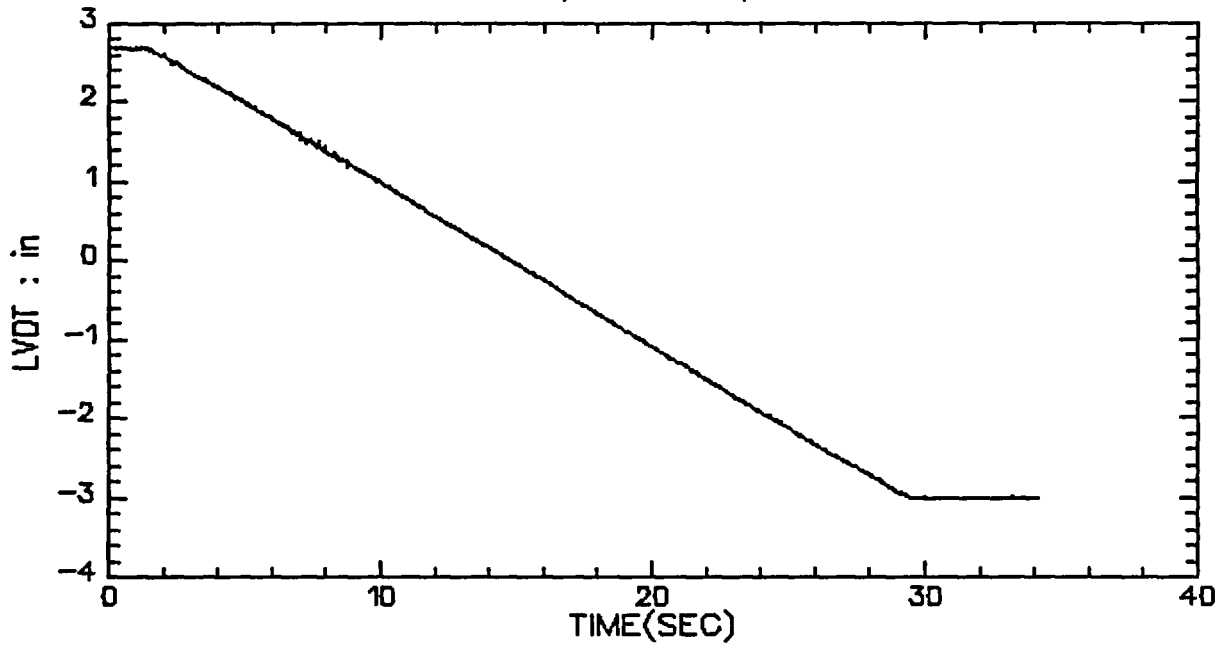

VALVE B, TEST 4, STEP 1

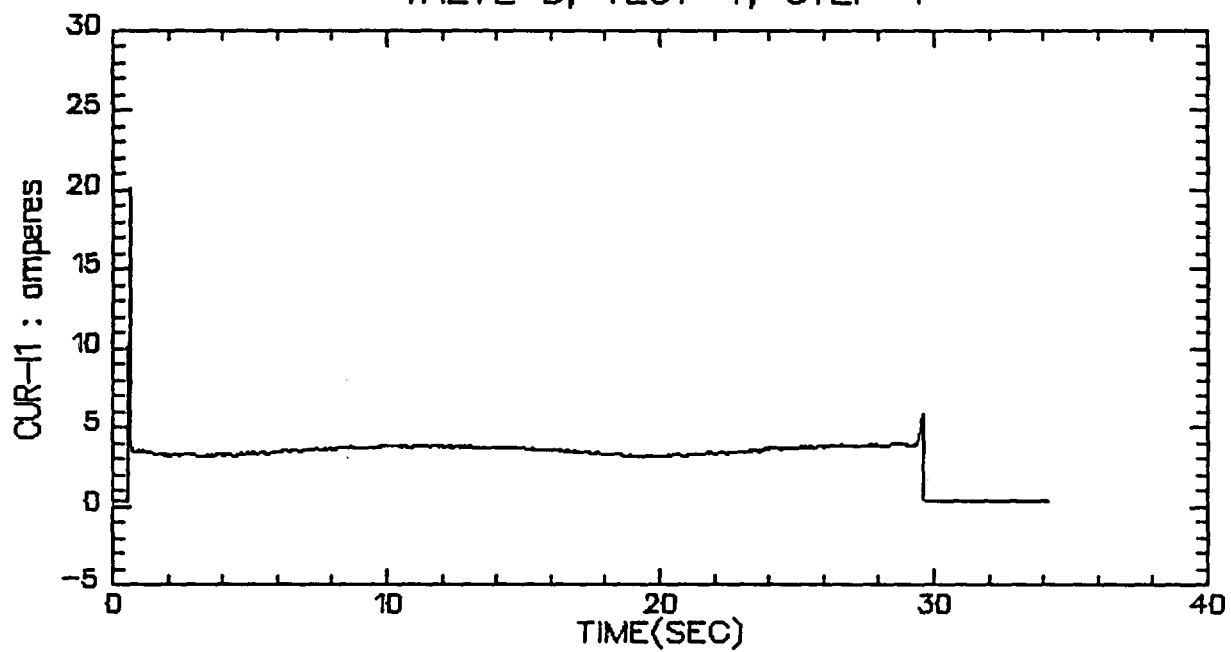

VALVE B, TEST 4, STEP 1

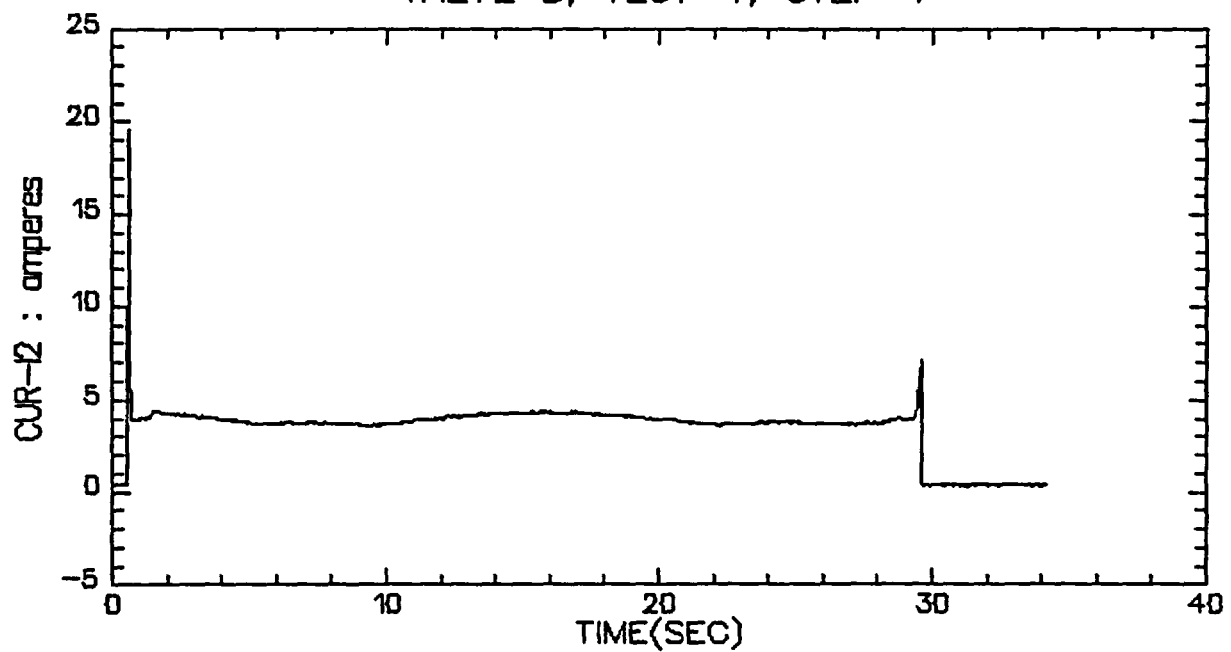

VALVE B, TEST 4, STEP 1

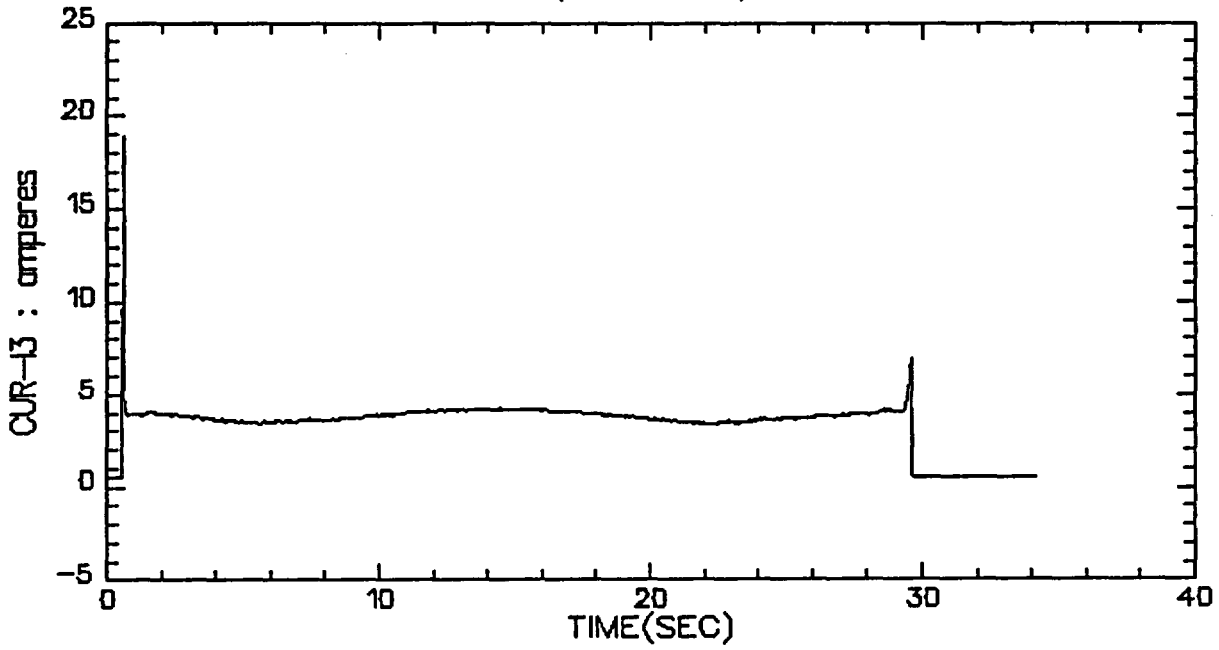

VALVE B, TEST 4, STEP 1

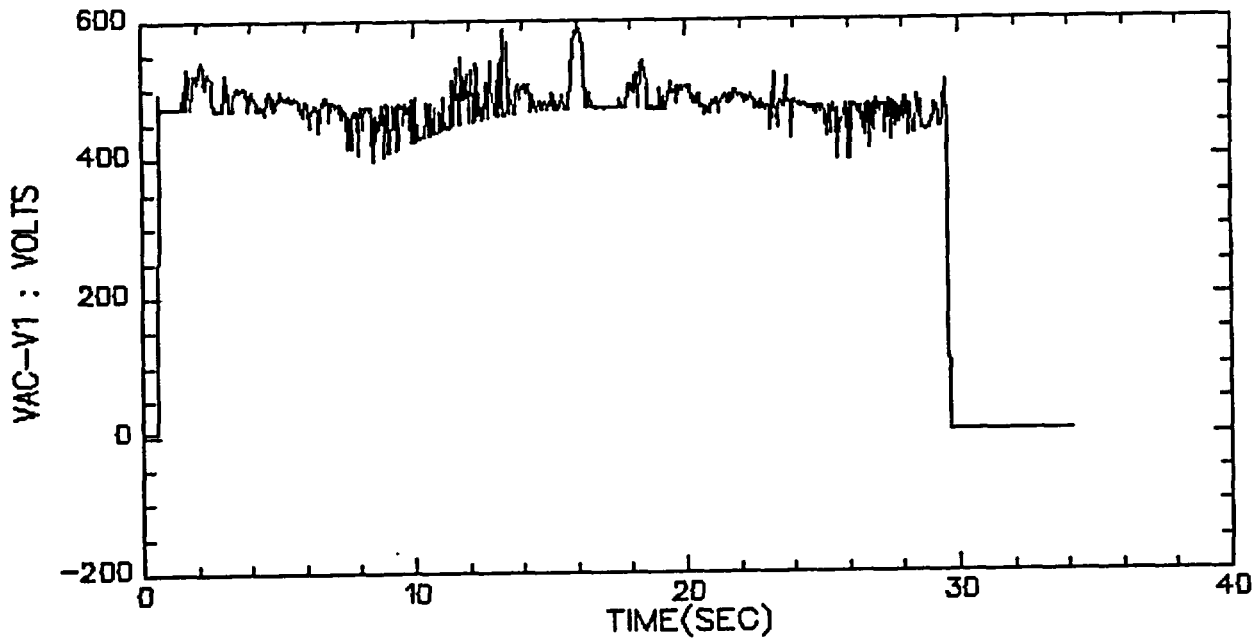

VALVE B, TEST 4, STEP 1

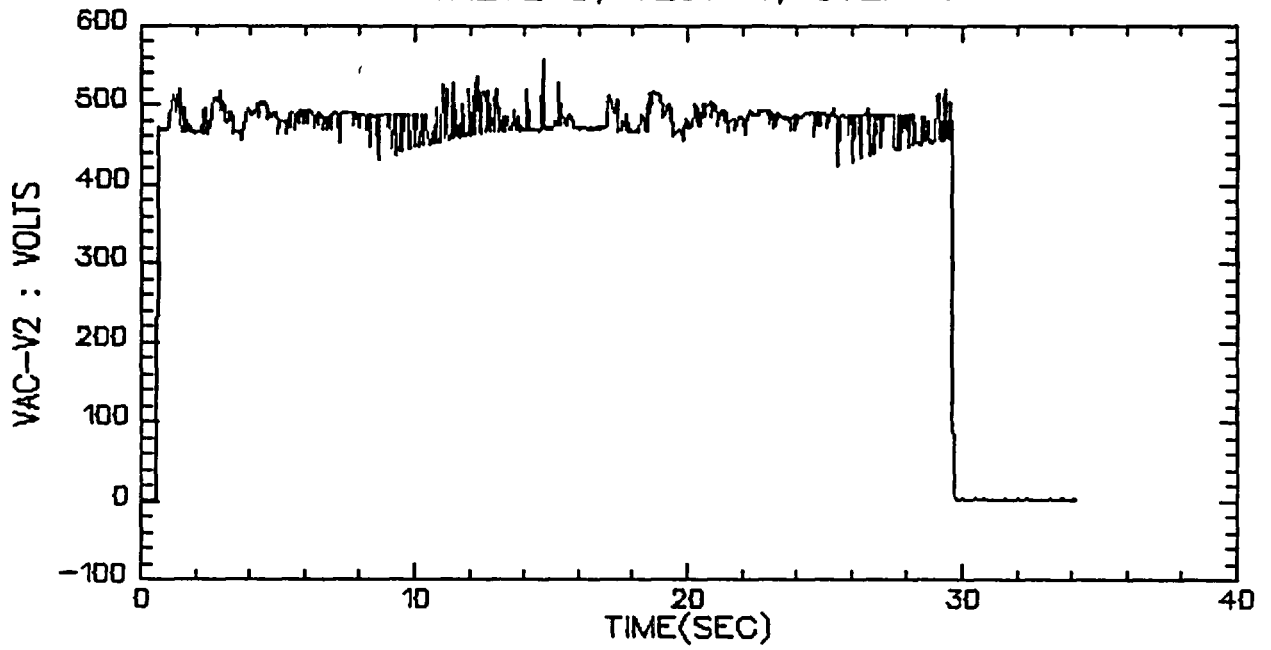

VALVE B, TEST 4, STEP 1

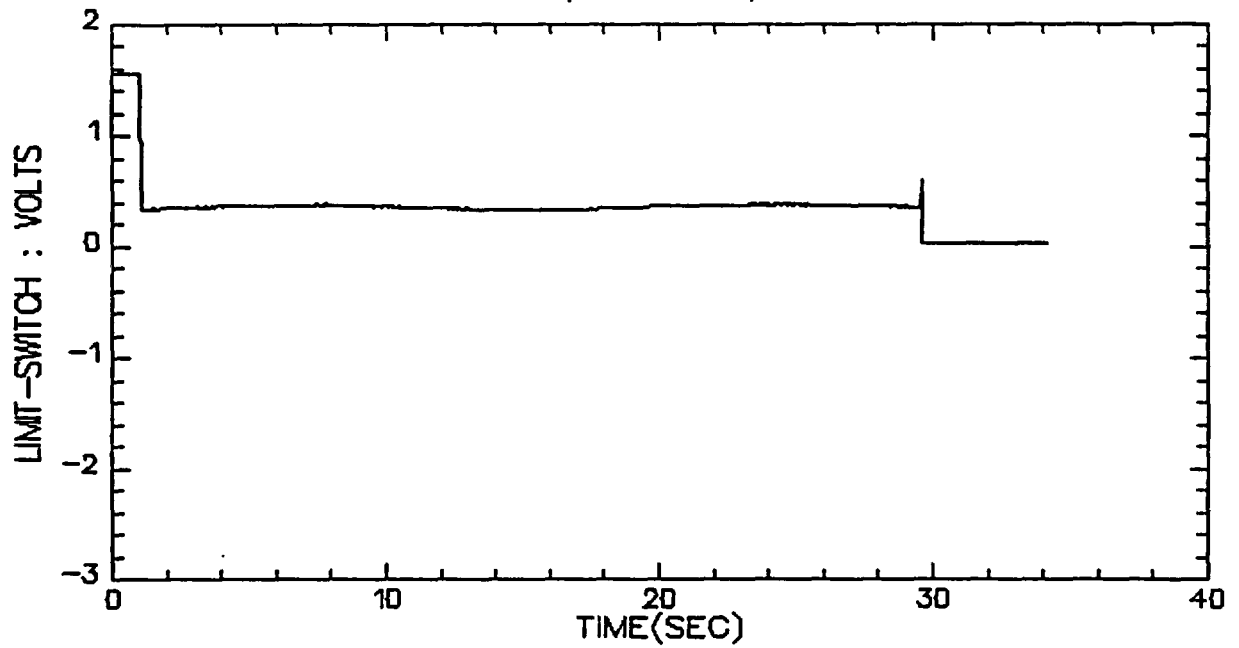

VALVE B, TEST 4, STEP 1

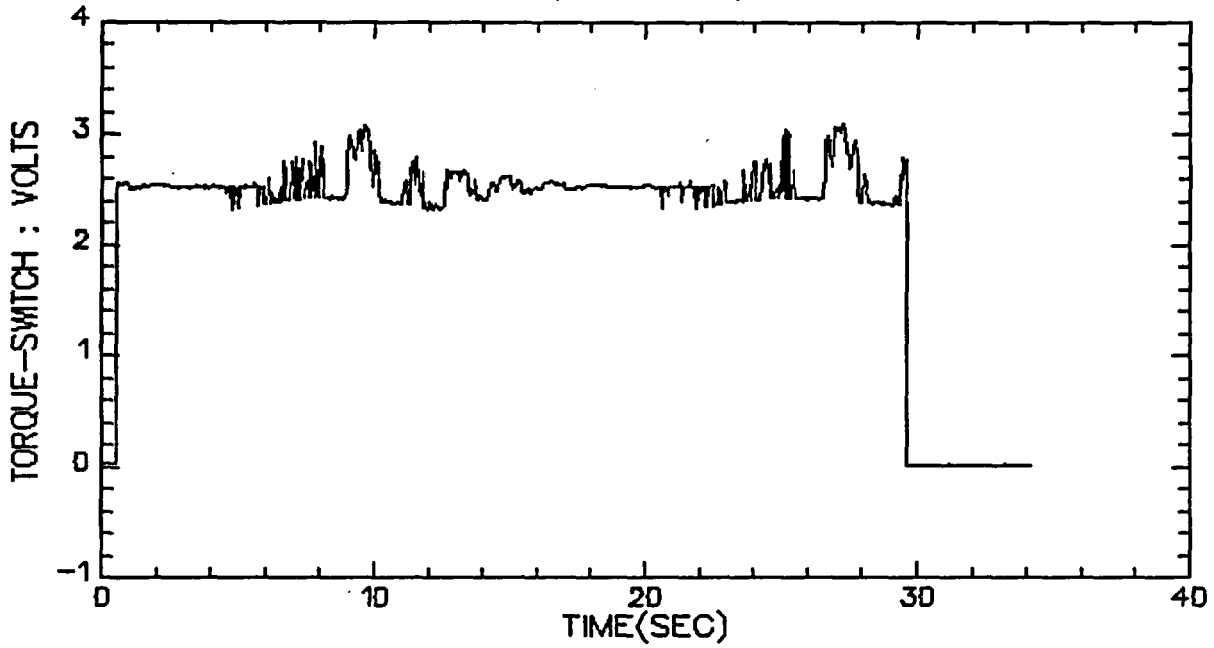

VALVE B, TEST 4, STEP 1

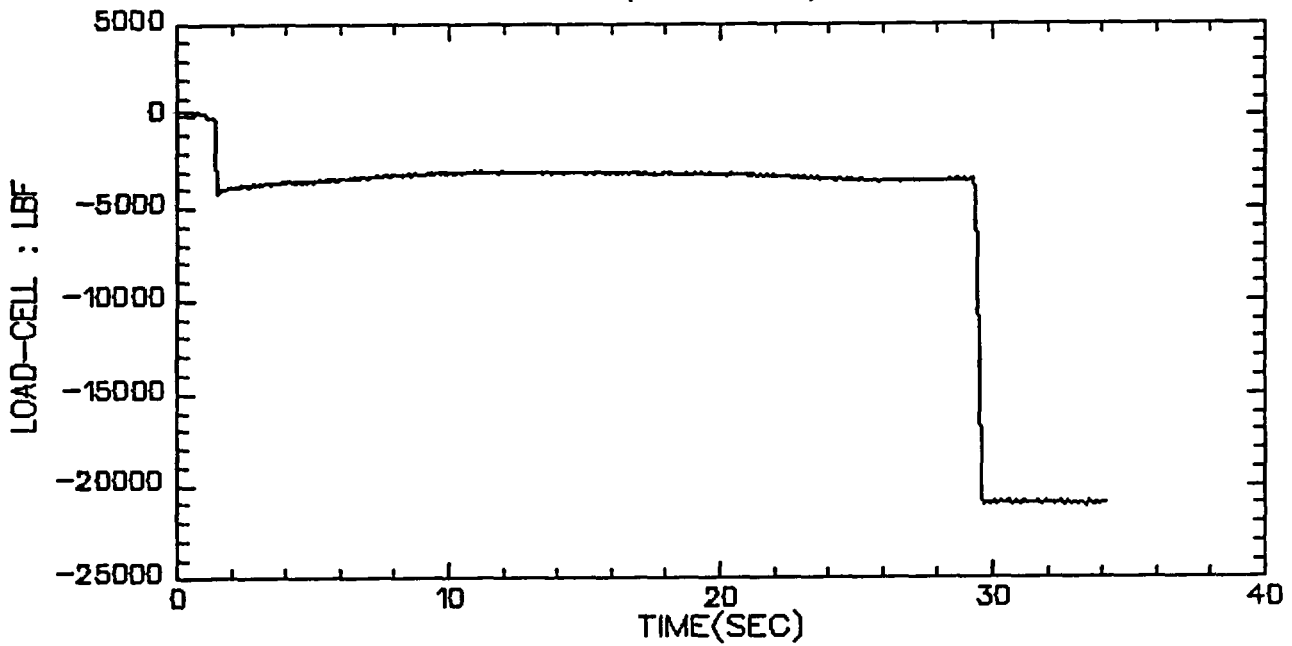

VALVE B, TEST 4, STEP 2

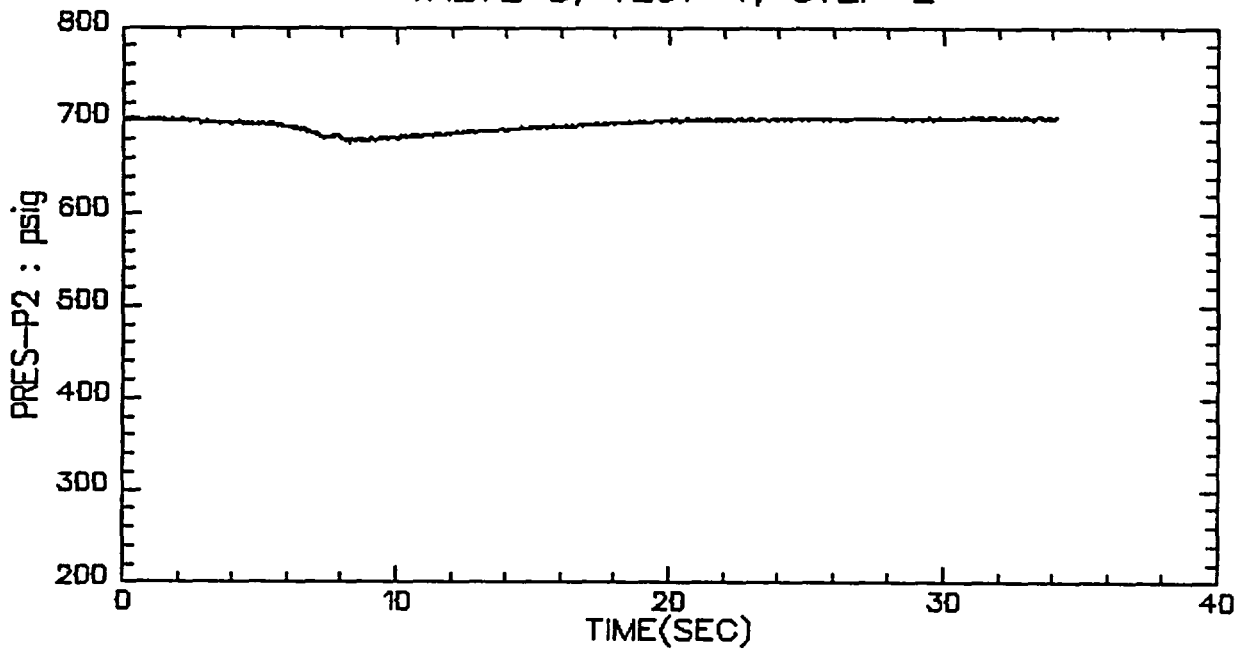

VALVE B, TEST 4, STEP 2

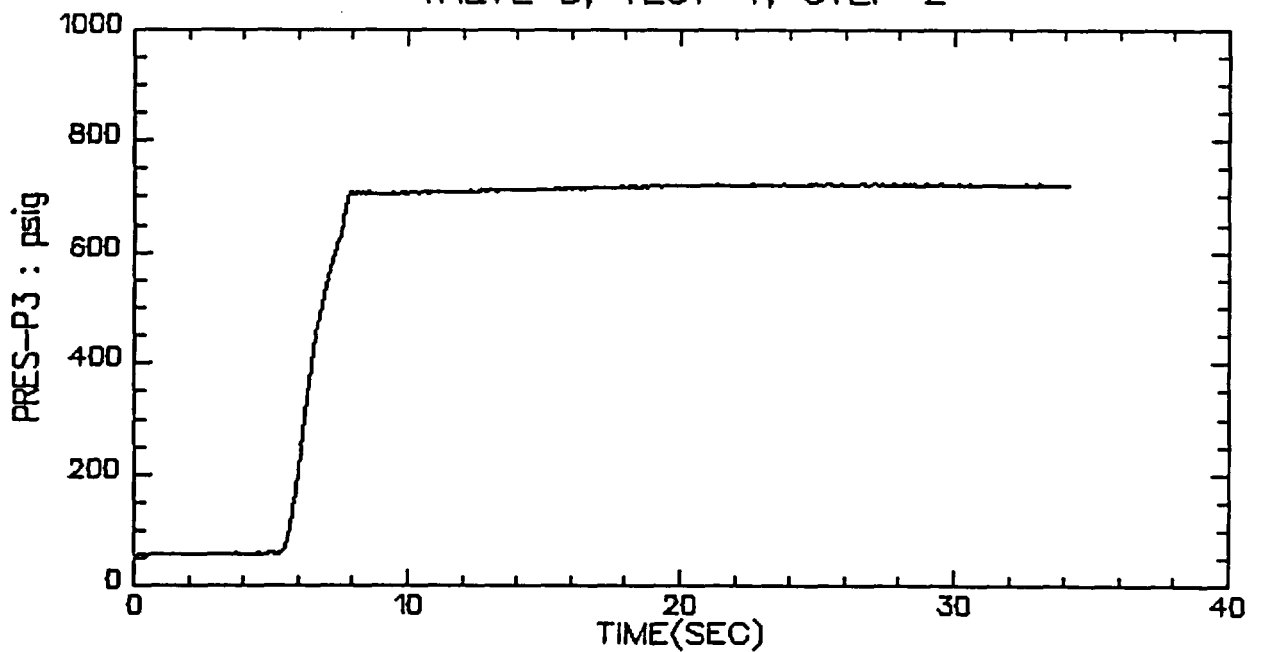

VALVE B, TEST 4, STEP 2

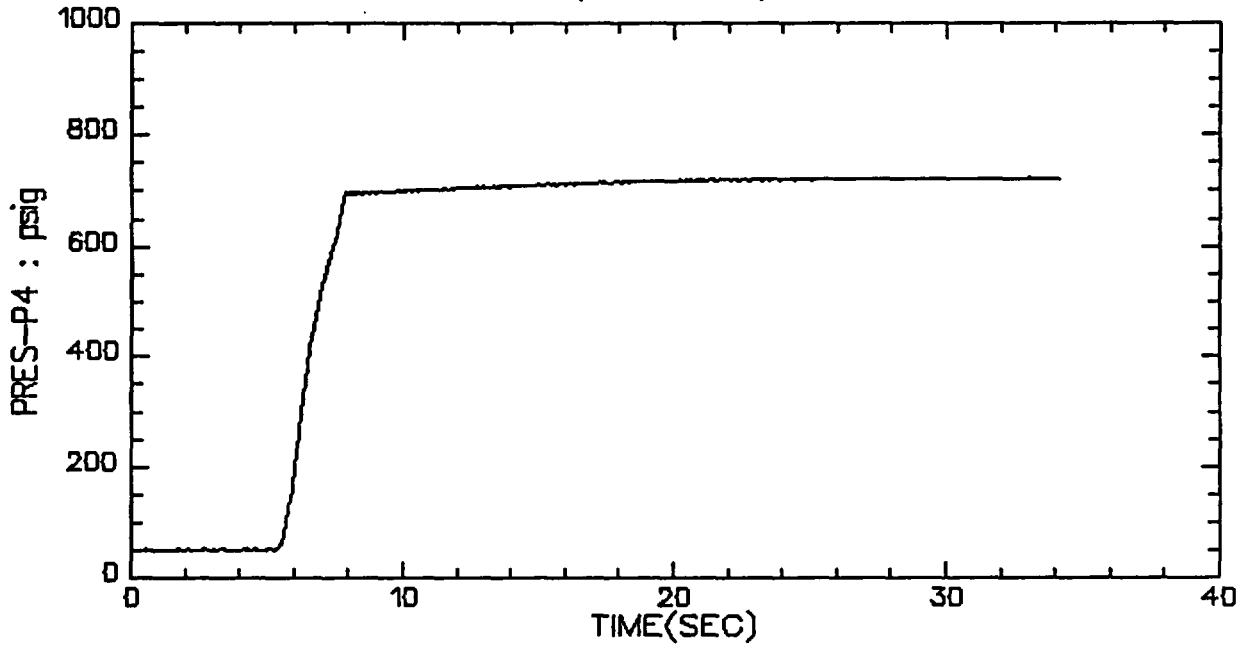

VALVE B, TEST 4, STEP 2

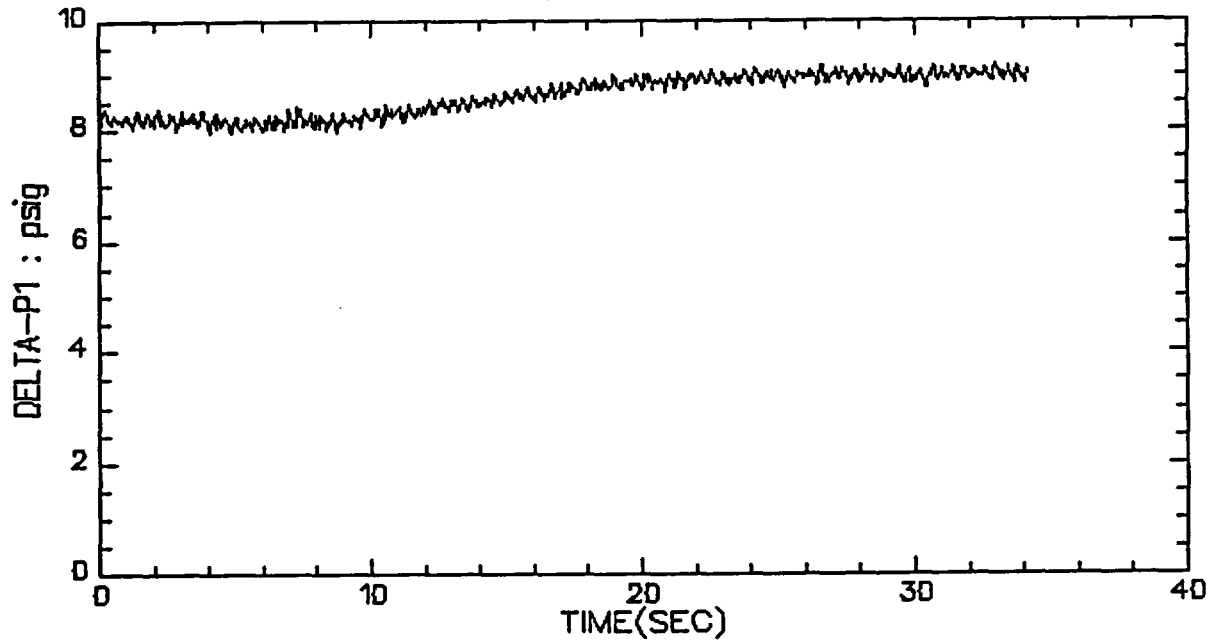

VALVE B, TEST 4, STEP 2

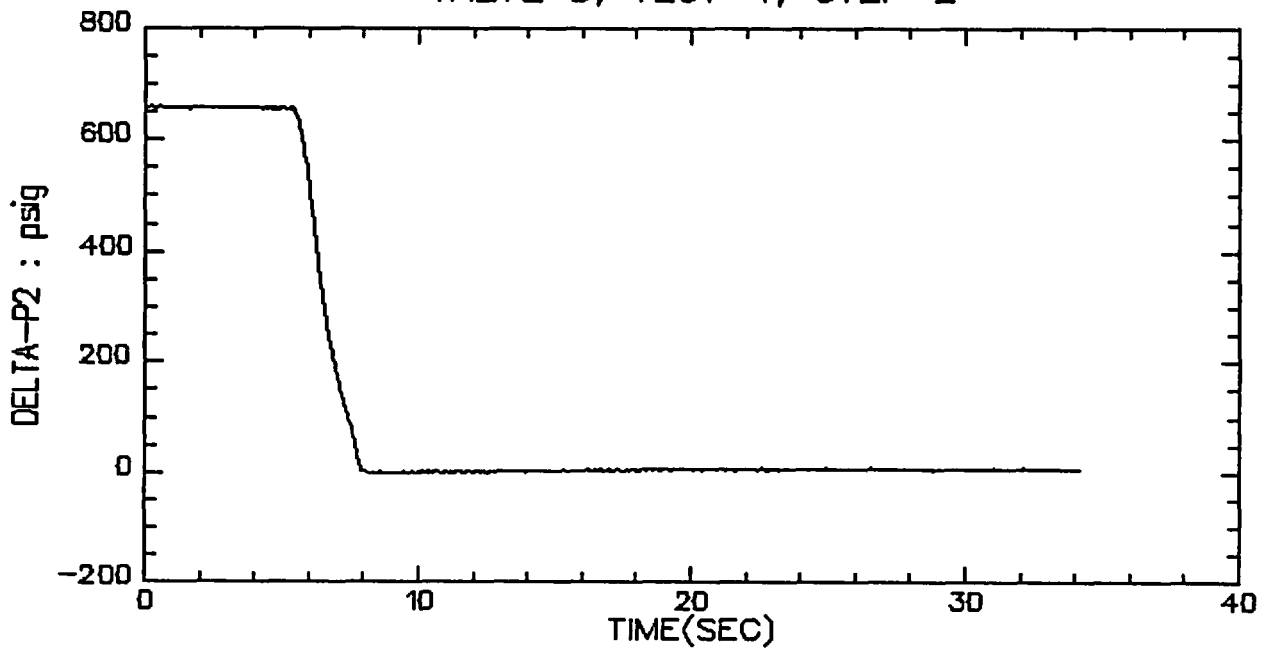

VALVE B, TEST 4, STEP 2

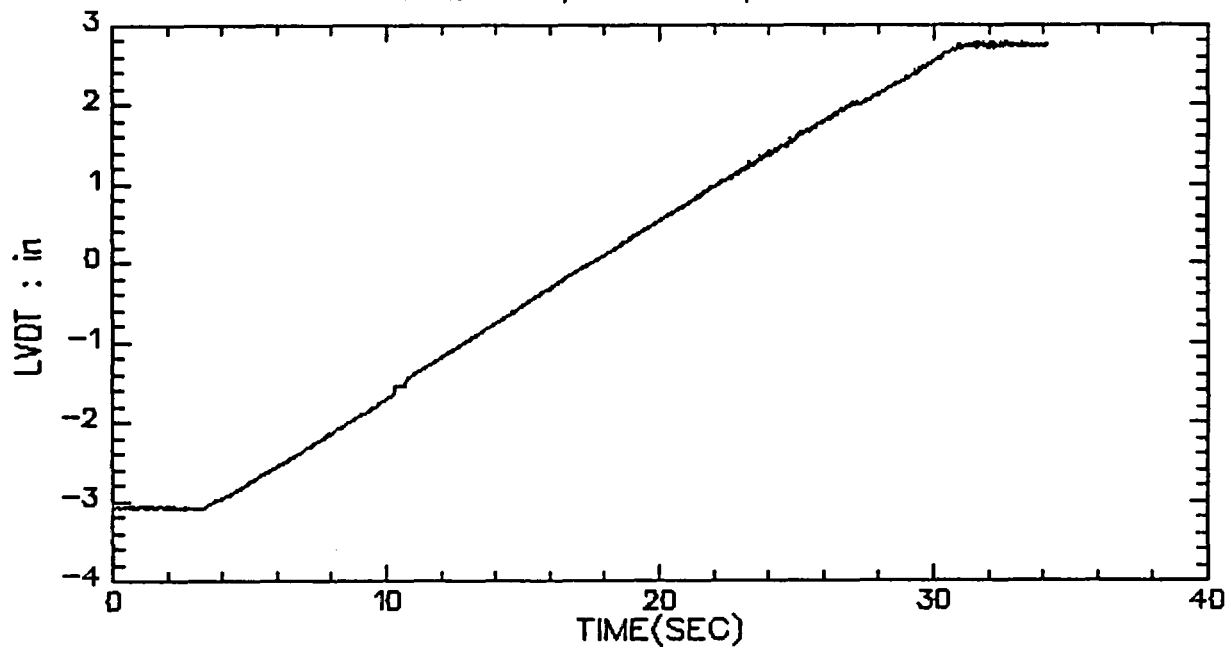

VALVE B, TEST 4, STEP 2

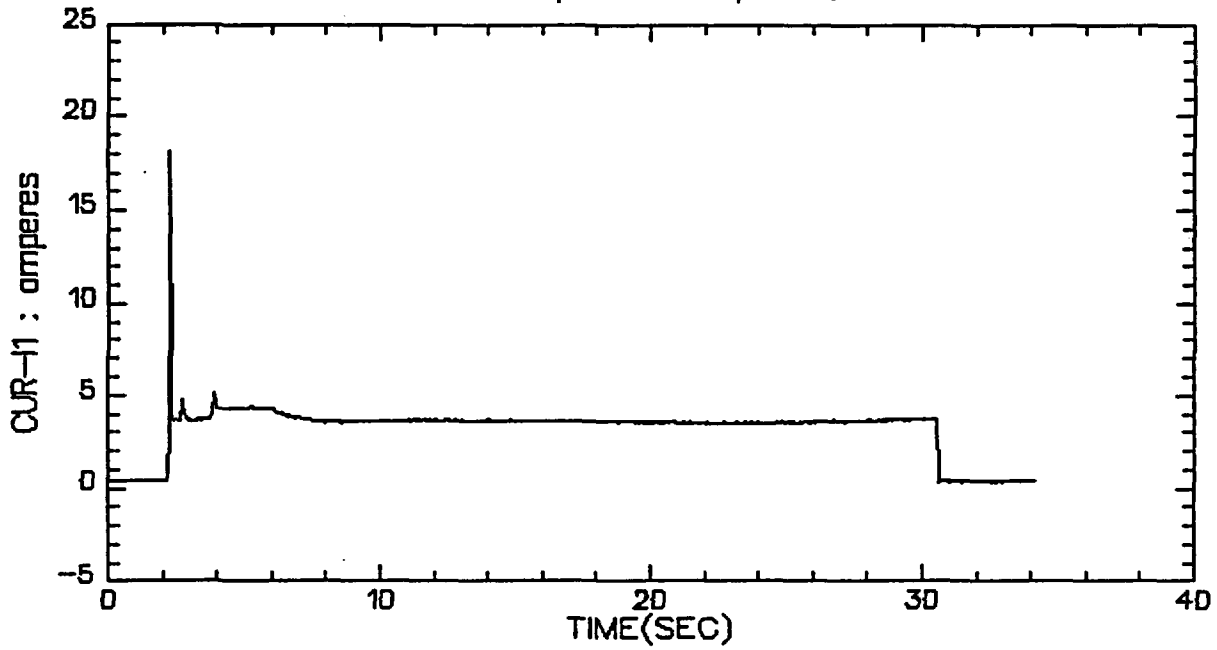

VALVE B, TEST 4, STEP 2

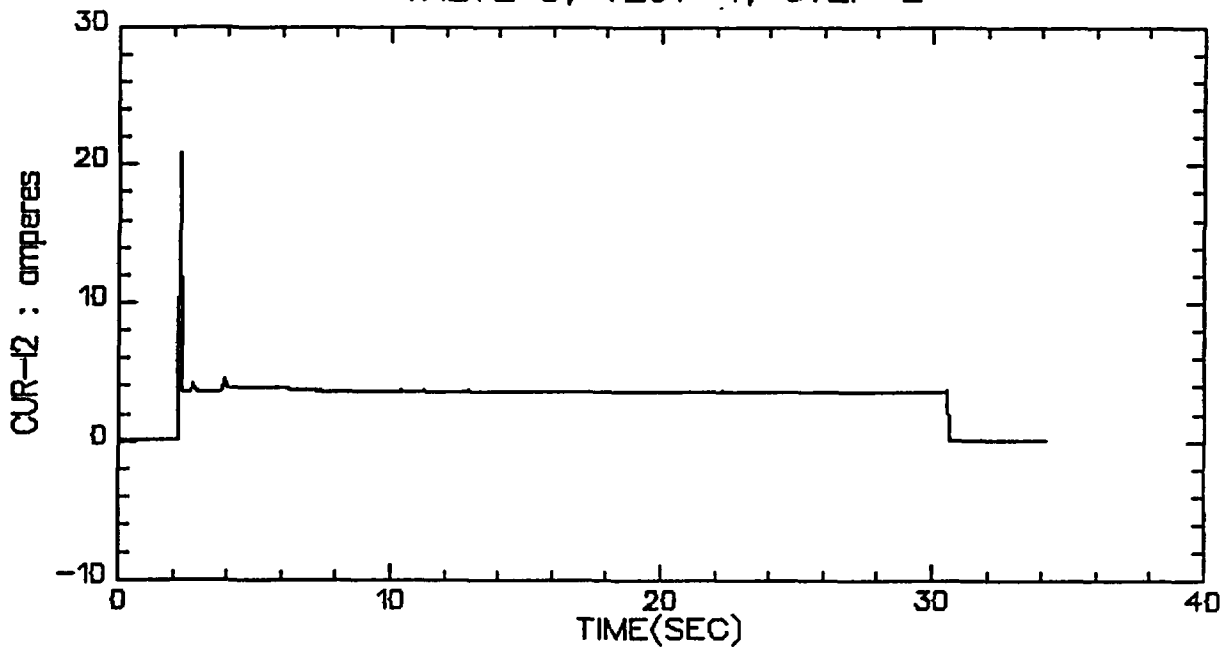

VALVE B, TEST 4, STEP 2

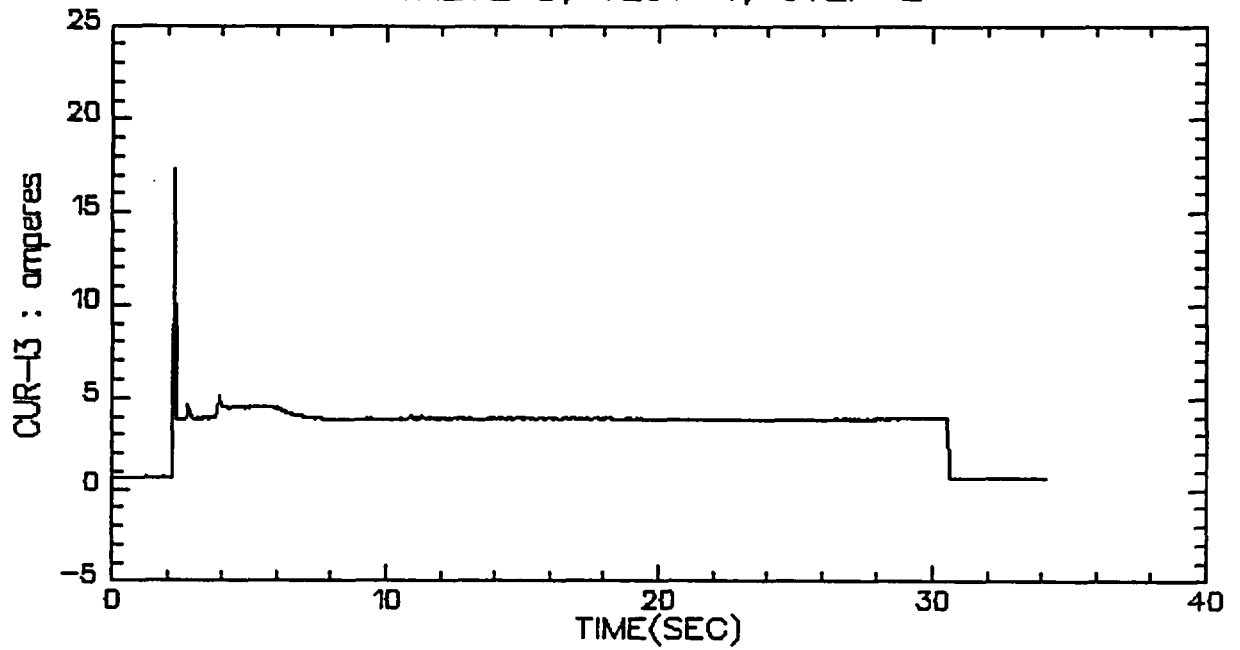

VALVE B, TEST 4, STEP 2

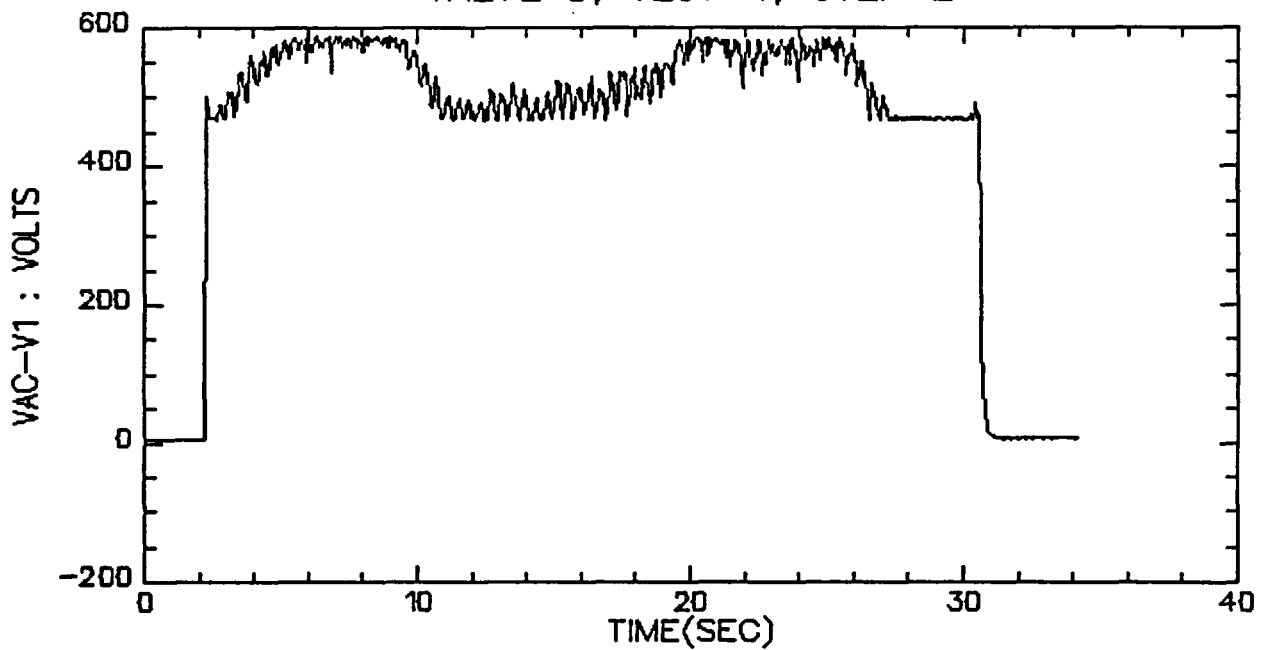

VALVE B, TEST 4, STEP 2

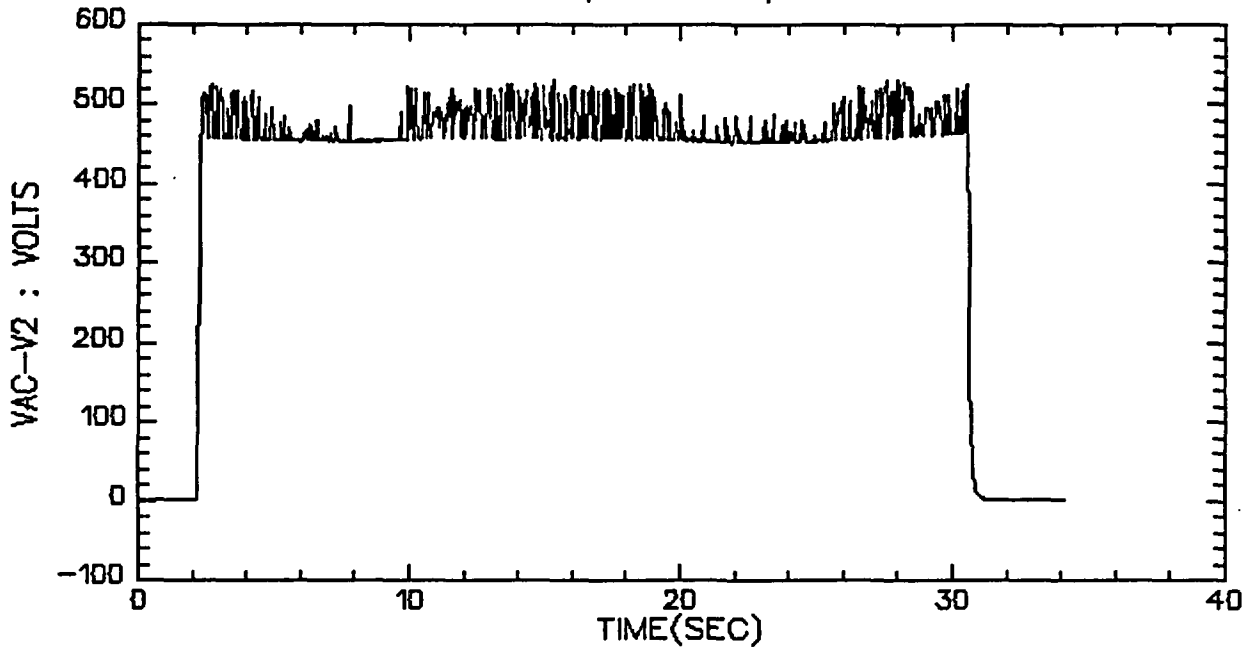

VALVE B, TEST 4, STEP 2

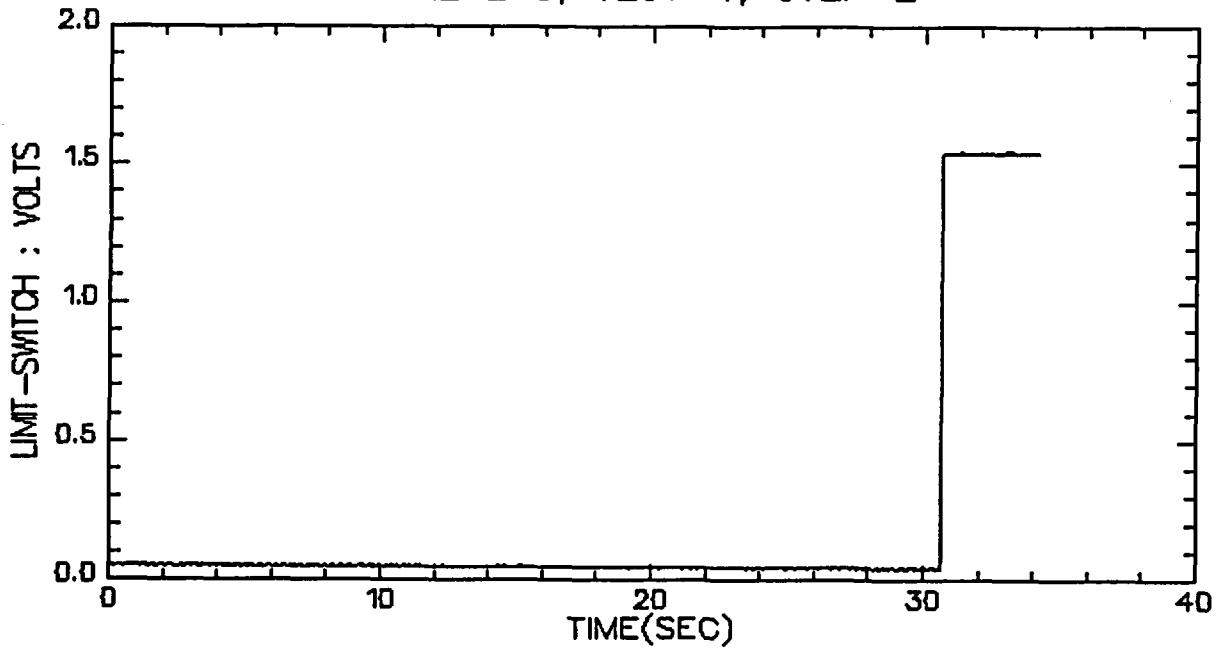

VALVE B, TEST 4, STEP 2

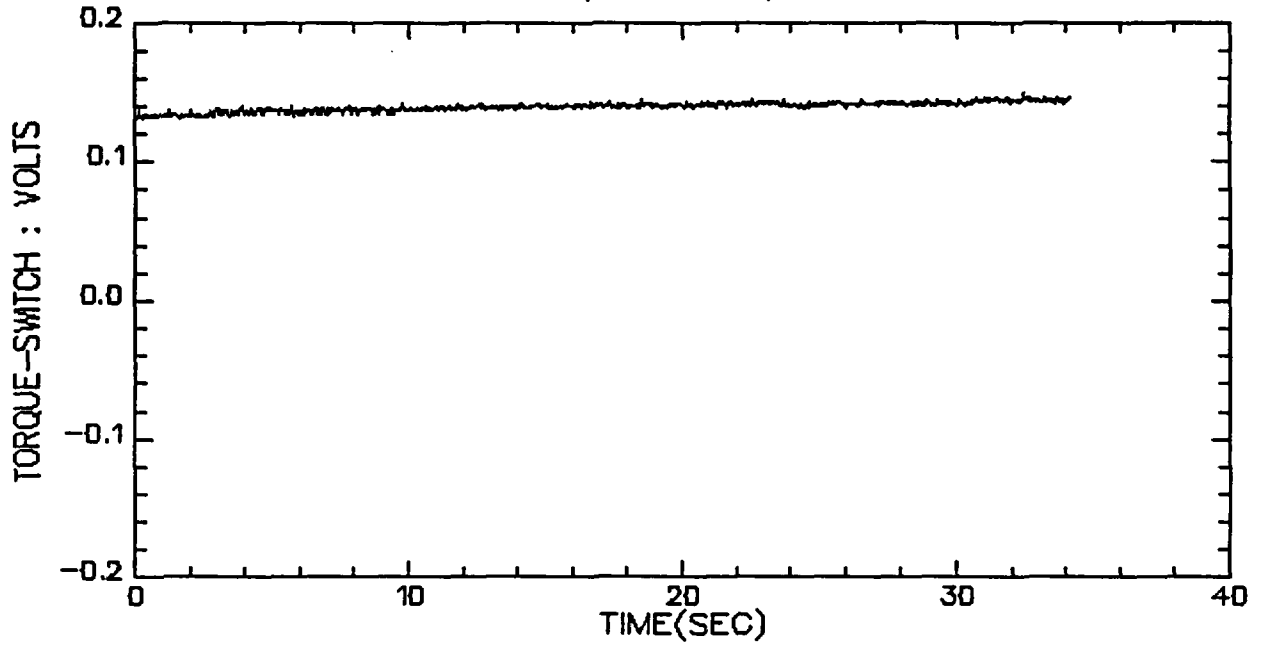

VALVE B, TEST 4, STEP 2

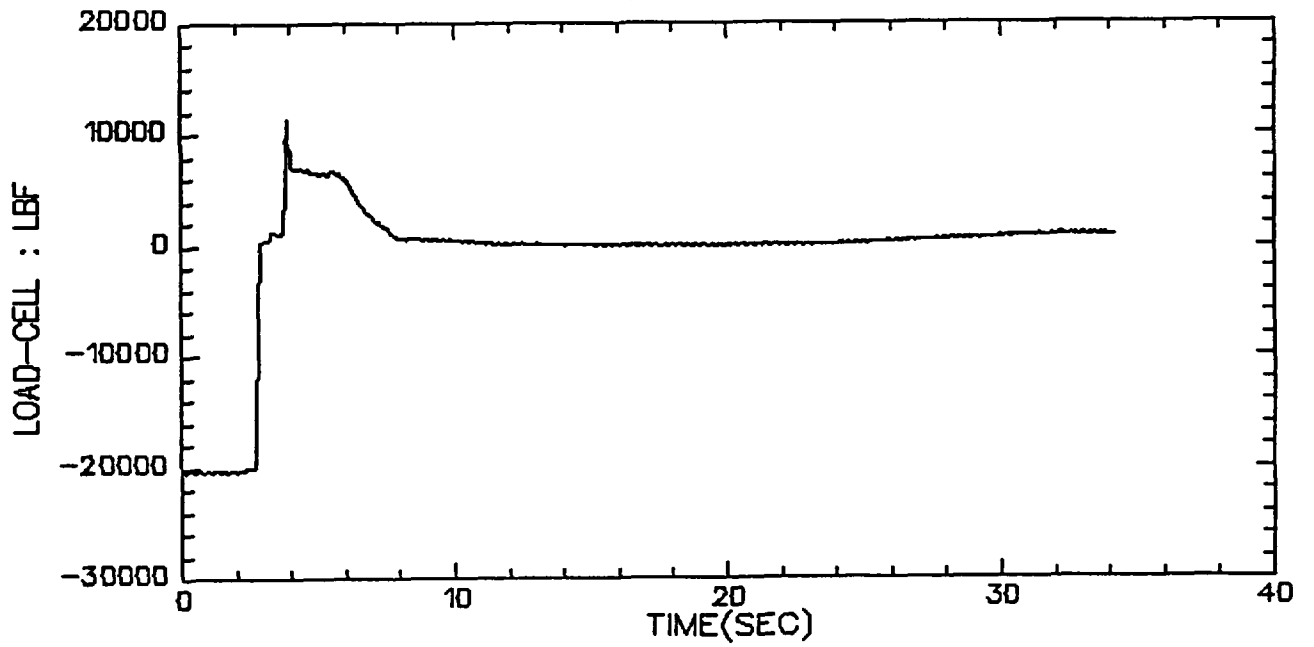

VALVE B, TEST 4, STEP 3&4

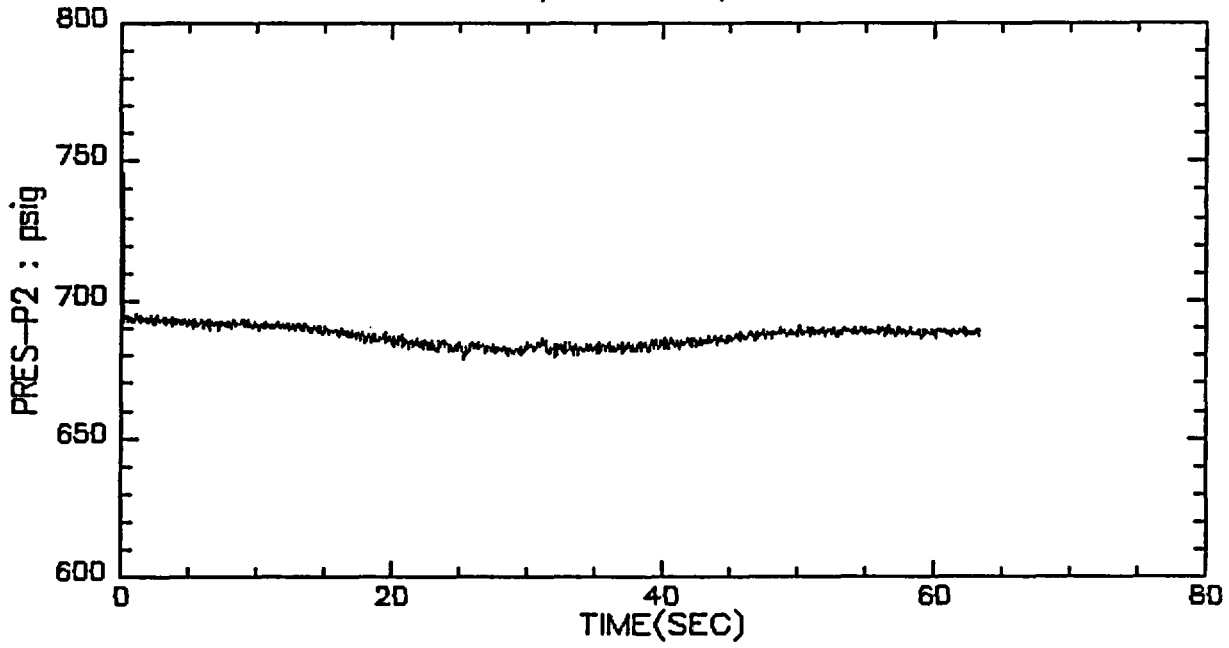

VALVE B, TEST 4, STEP 3&4

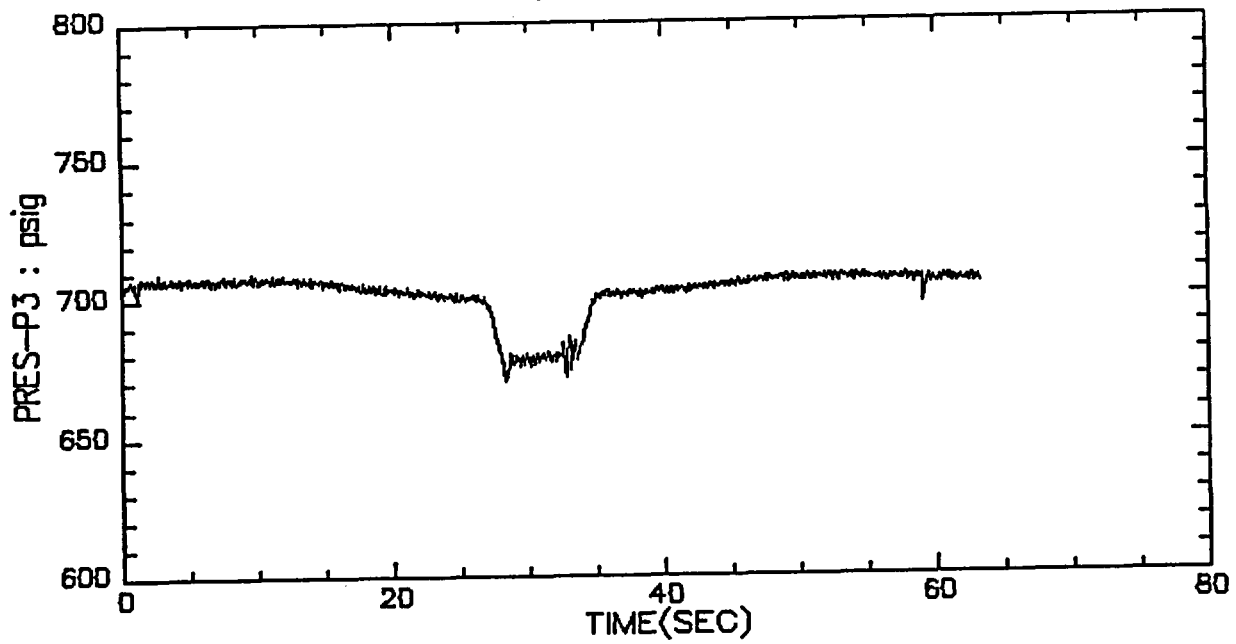

VALVE B, TEST 4, STEP 3&4

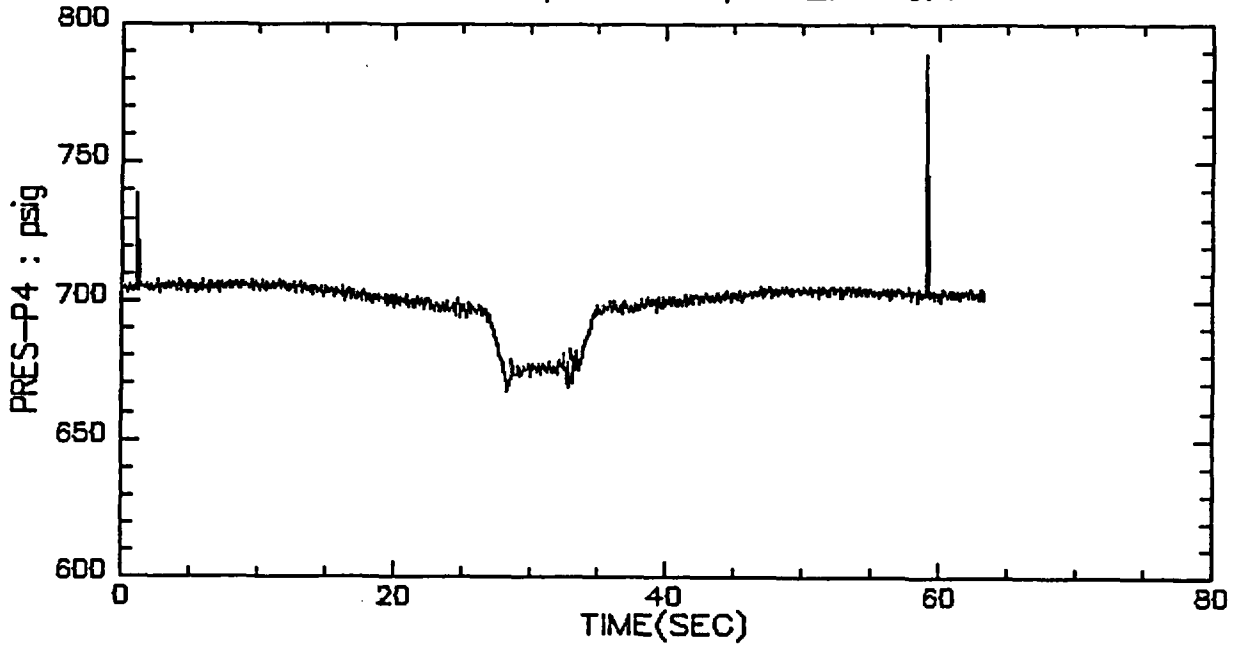

VALVE B, TEST 4, STEP 3&4

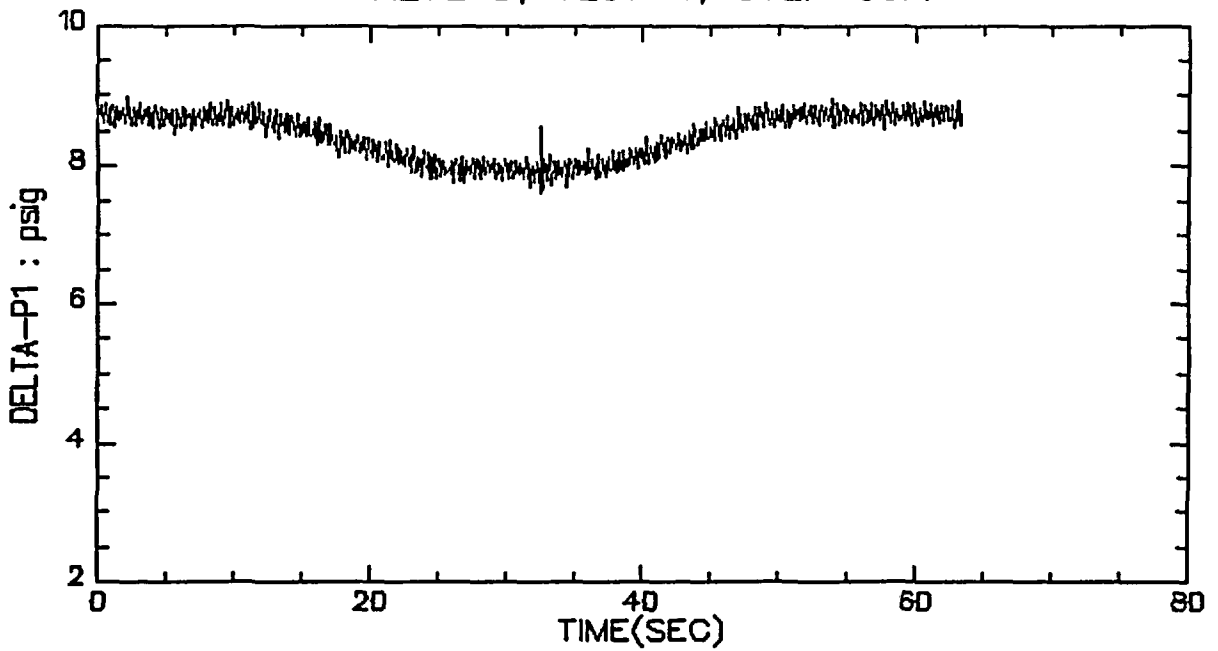

VALVE B, TEST 4, STEP 3&4

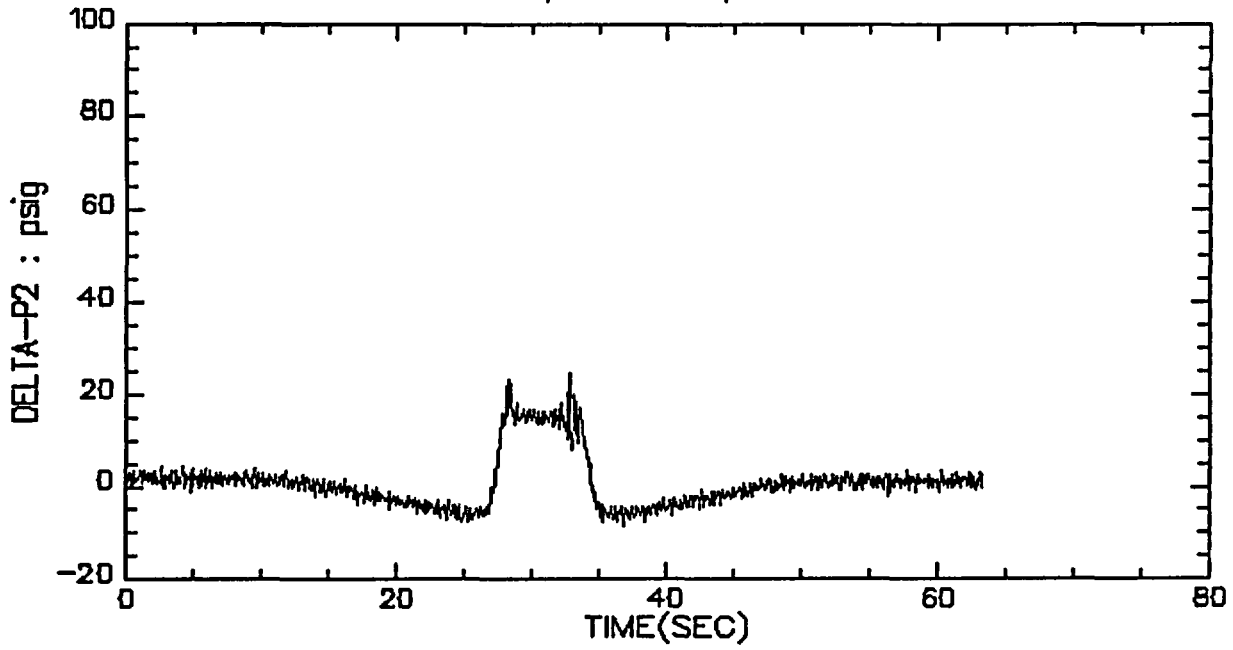

VALVE B, TEST 4, STEP 3&4

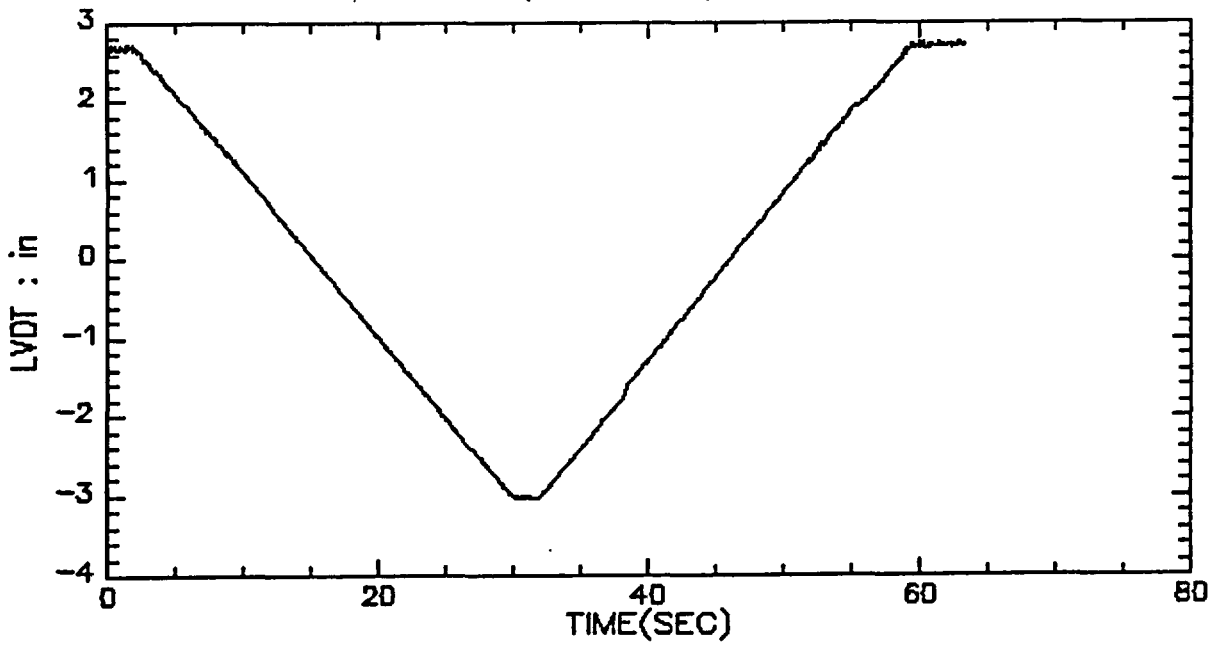

VALVE B, TEST 4, STEP 3&4

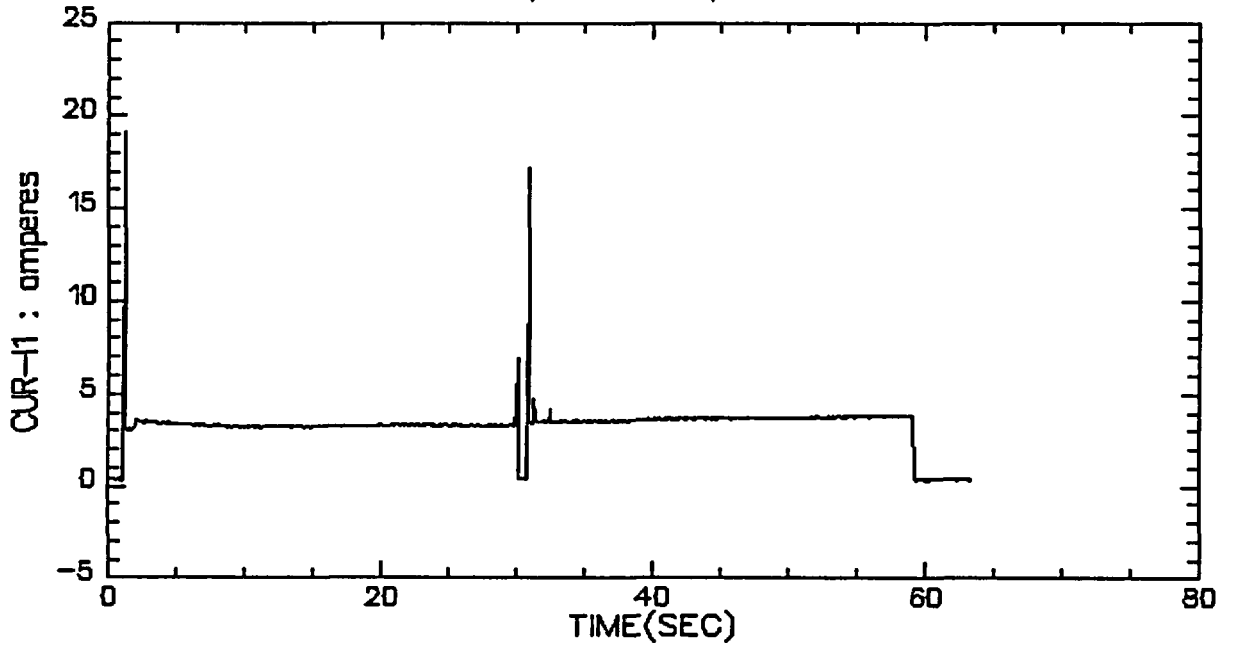

VALVE B, TEST 4, STEP 3&4

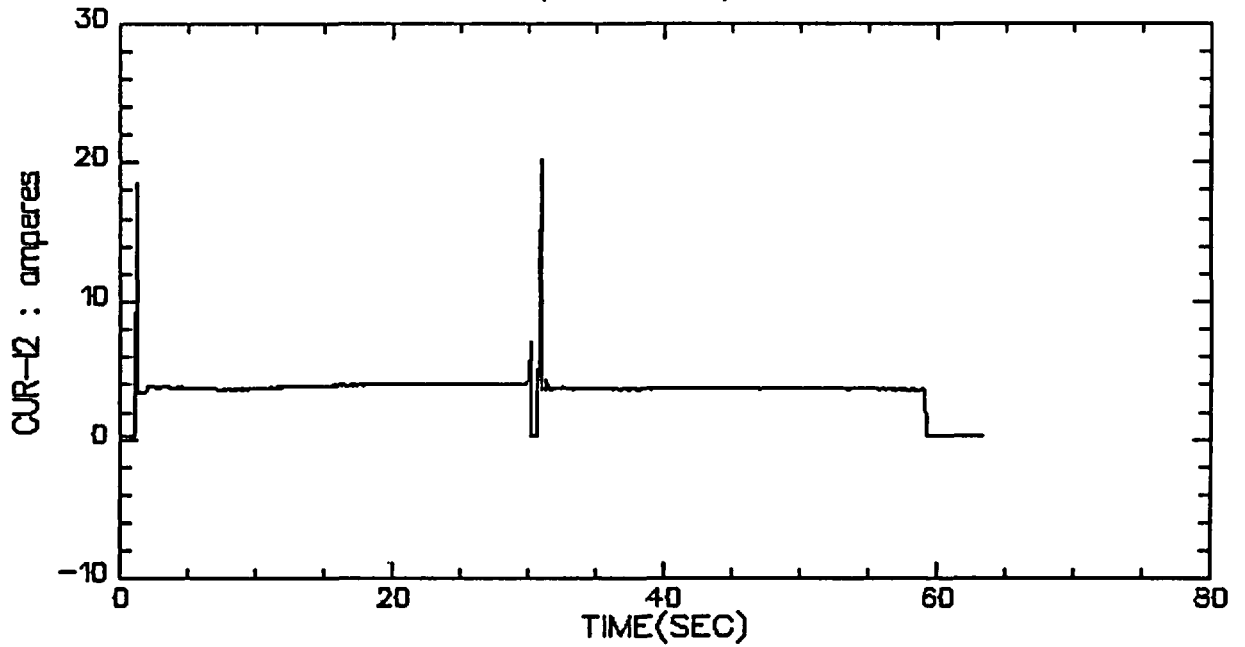

VALVE B, TEST 4, STEP 3&4

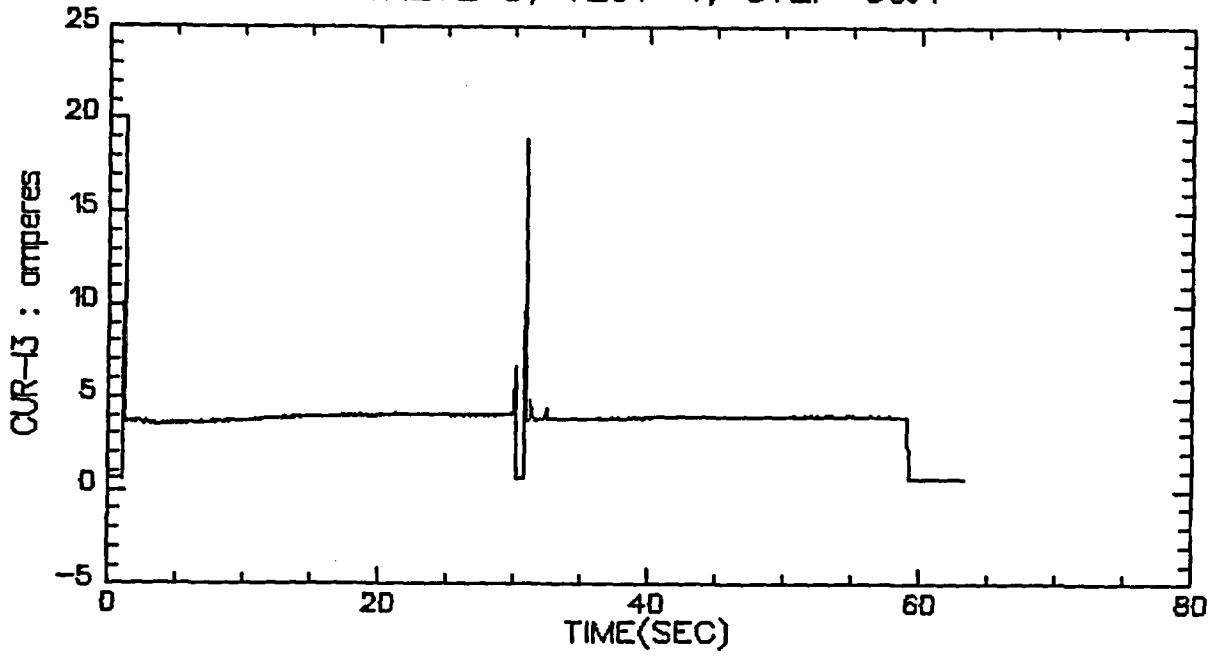

VALVE B, TEST 4, STEP 3&4

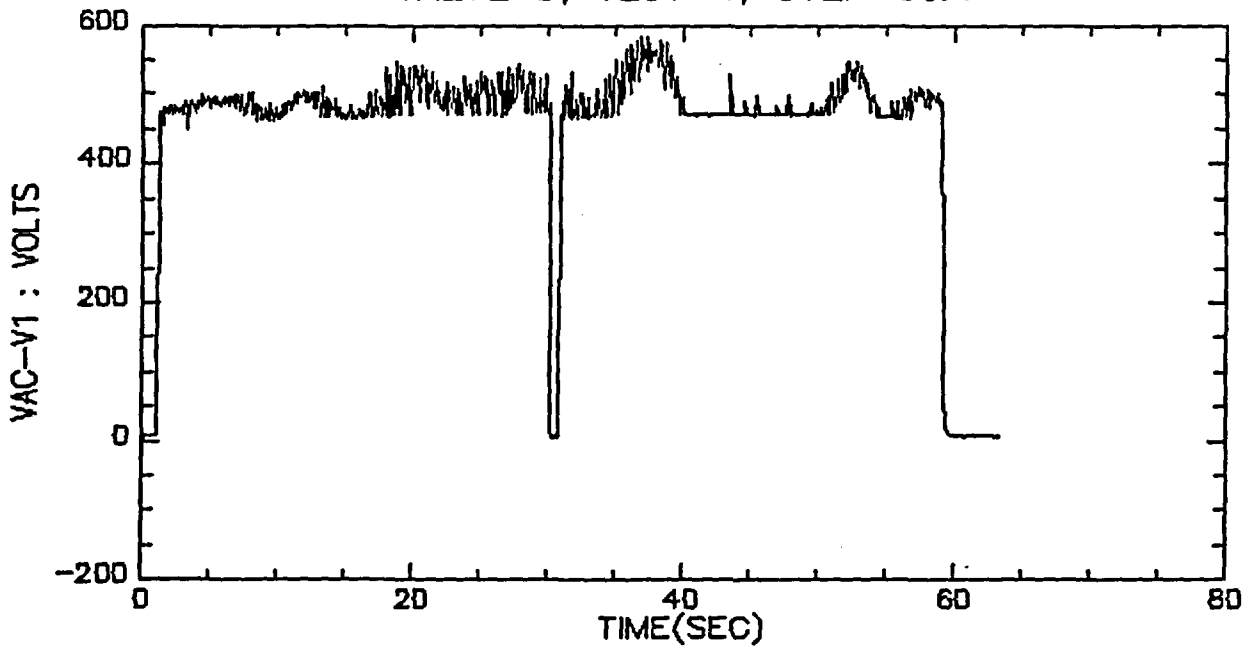

VALVE B, TEST 4, STEP 3&4

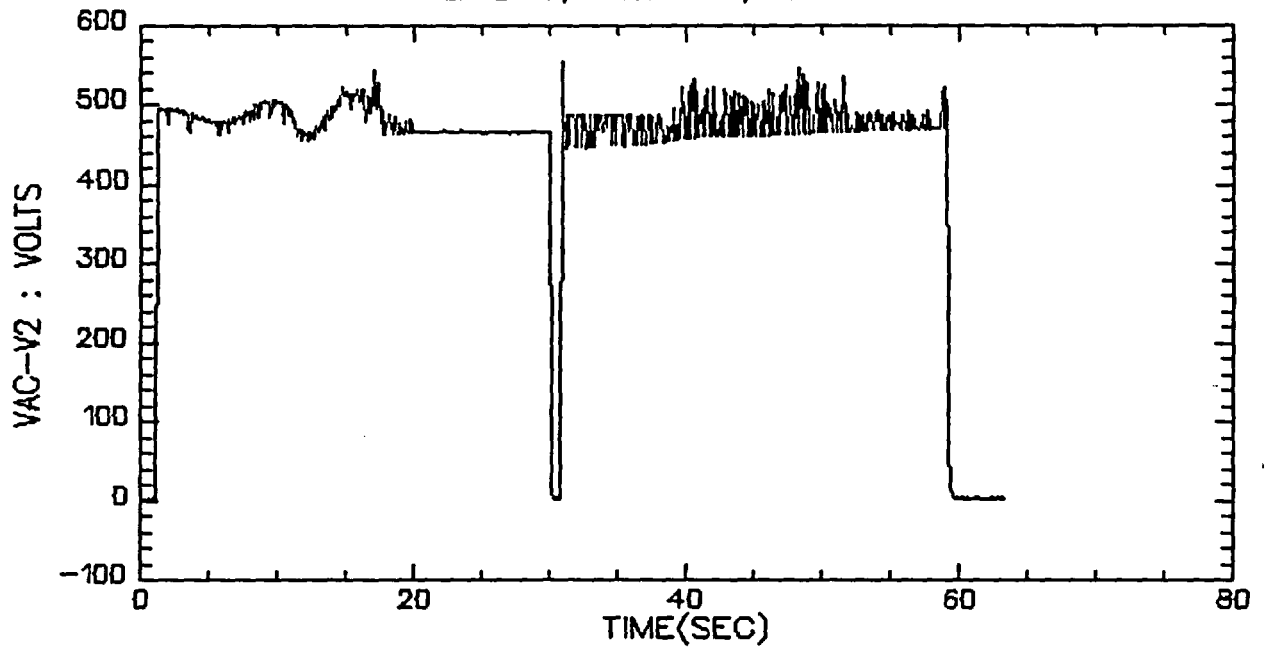

VALVE B, TEST 4, STEP 3&4

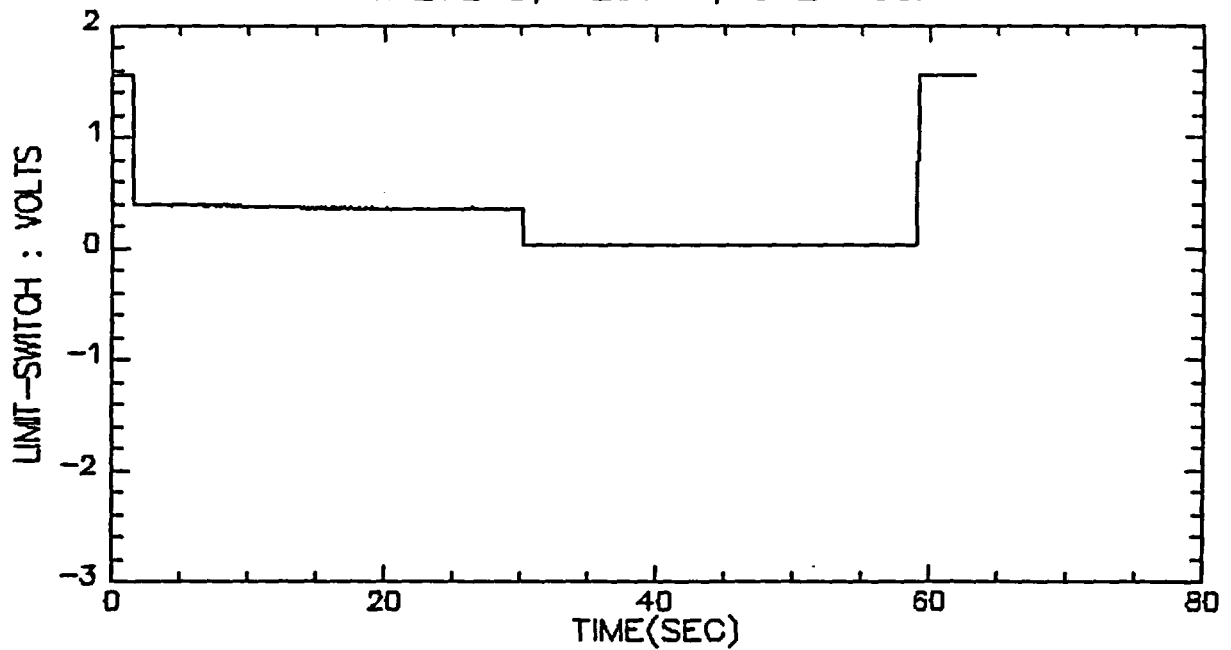

VALVE B, TEST 4, STEP 3&4

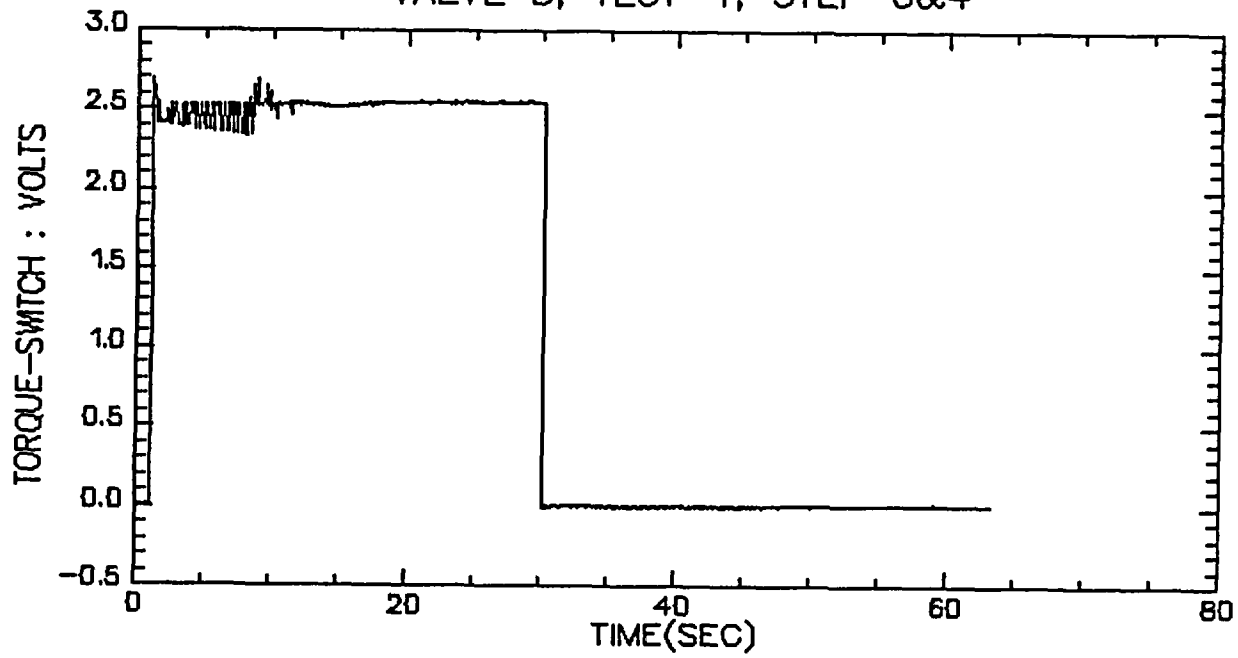

VALVE B, TEST 4, STEP 3&4

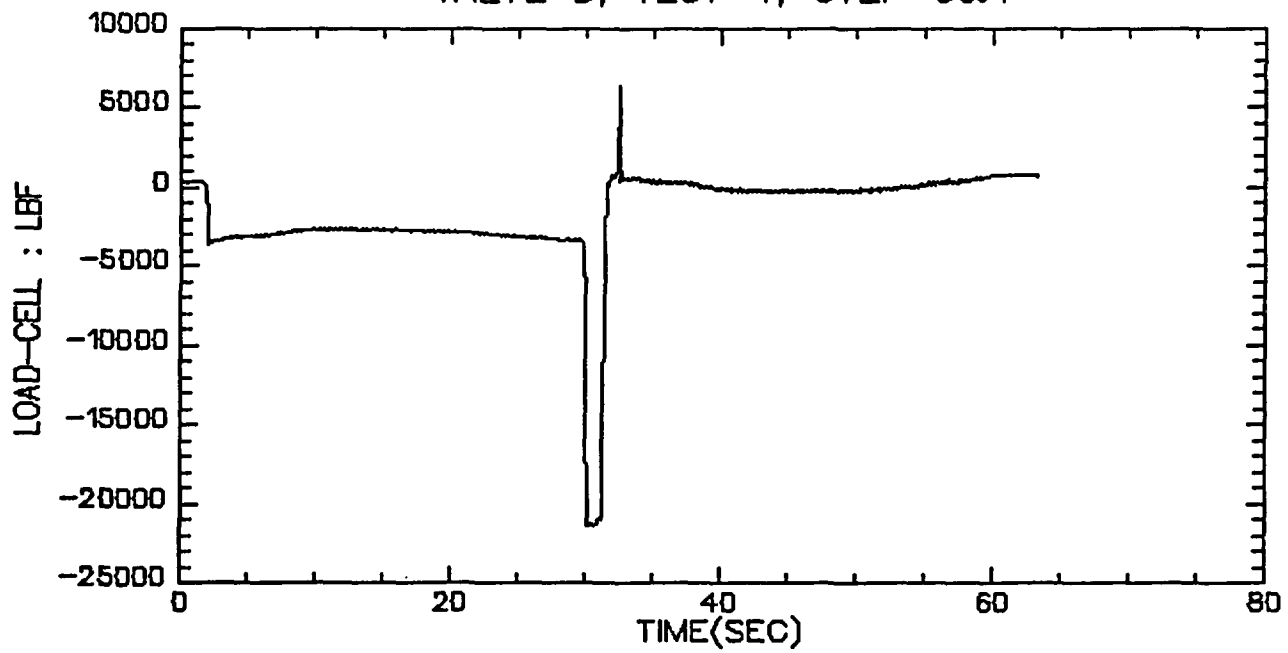

VALVE B, TEST 4, STEP 5

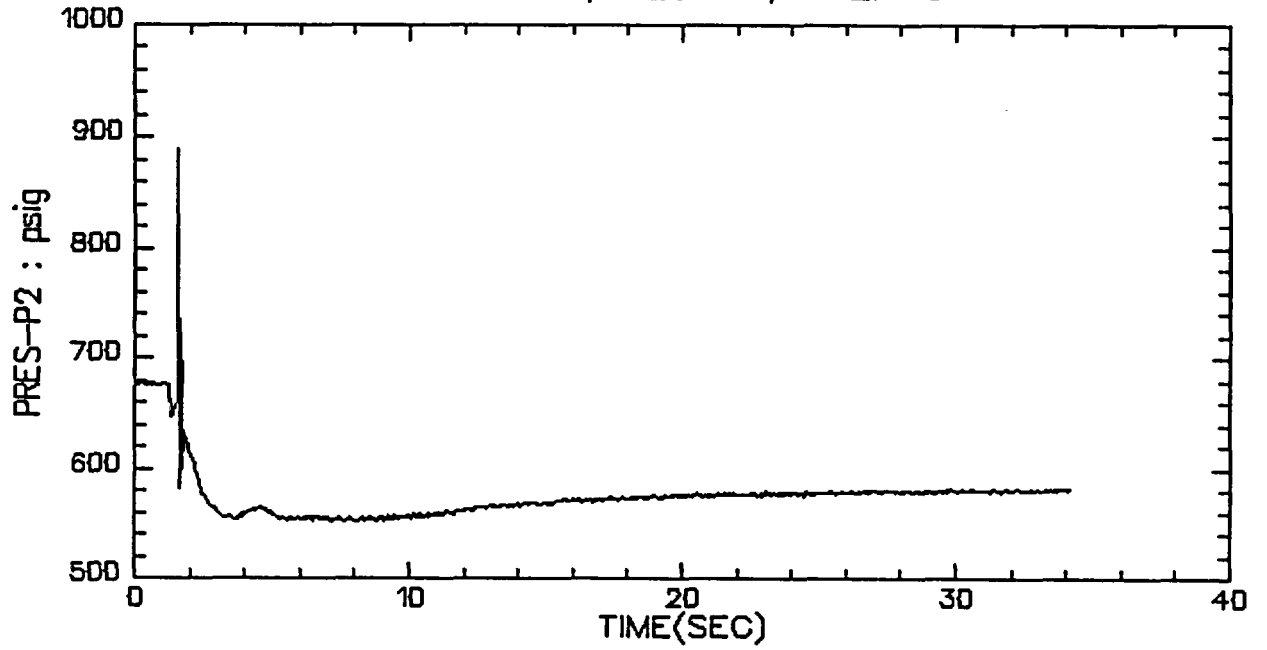

VALVE B, TEST 4, STEP 5

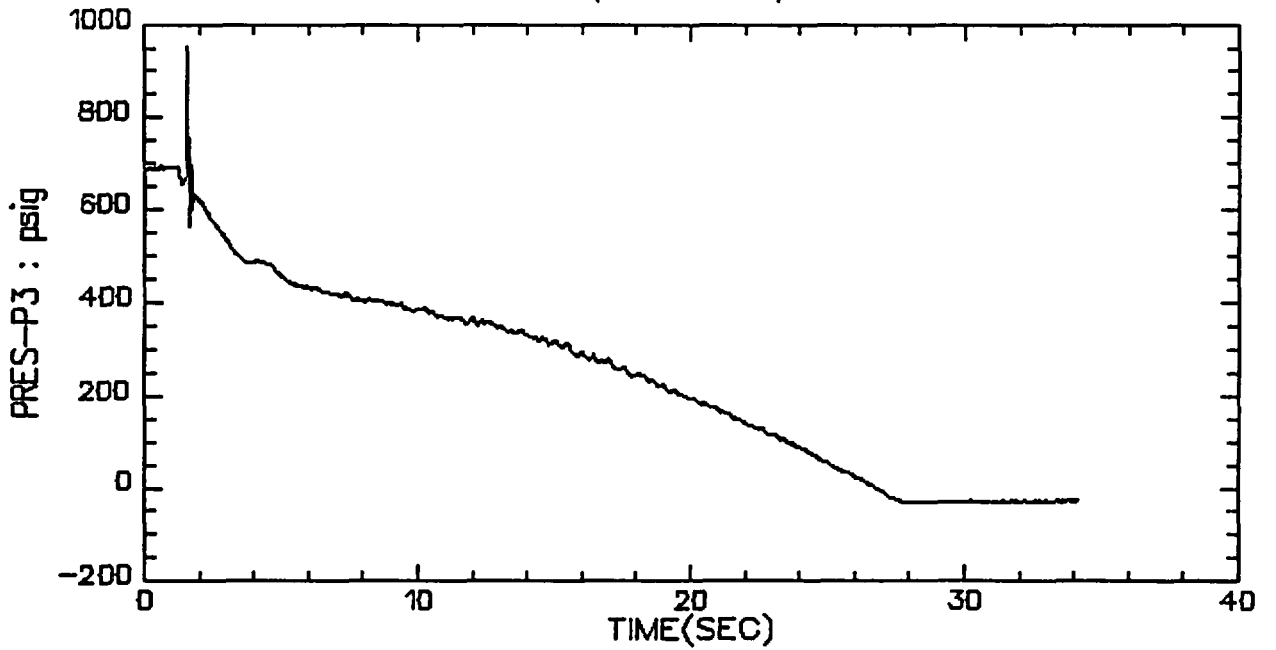

VALVE B, TEST 4, STEP 5

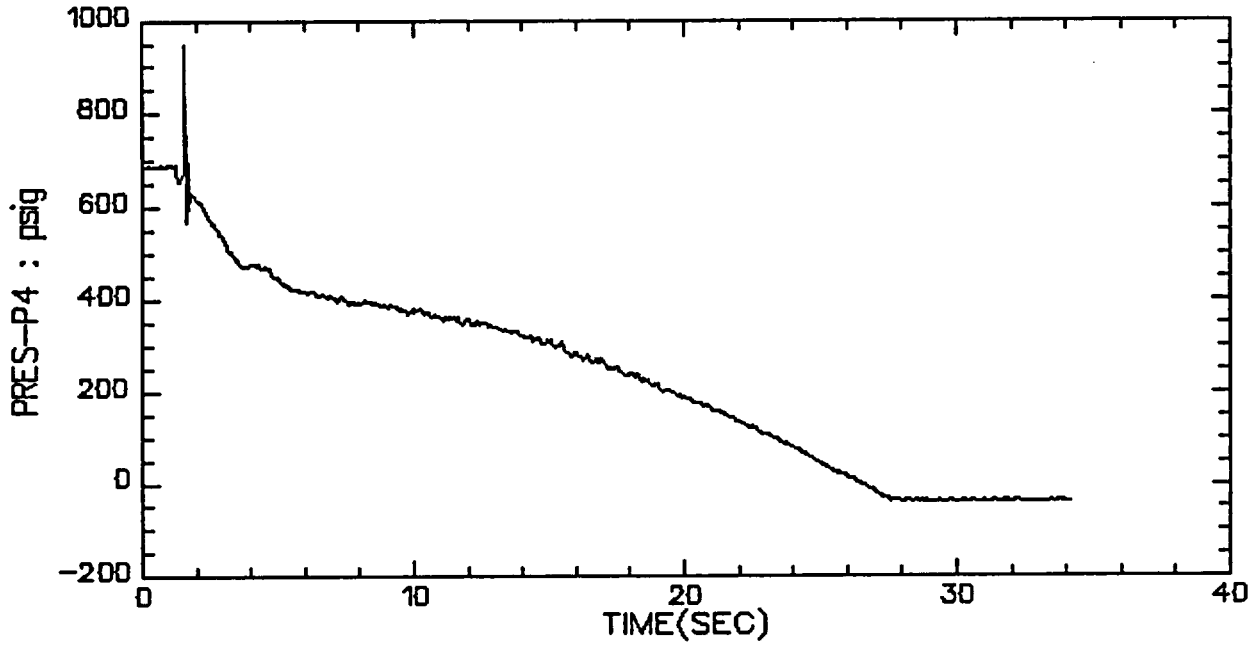

VALVE B, TEST 4, STEP 5

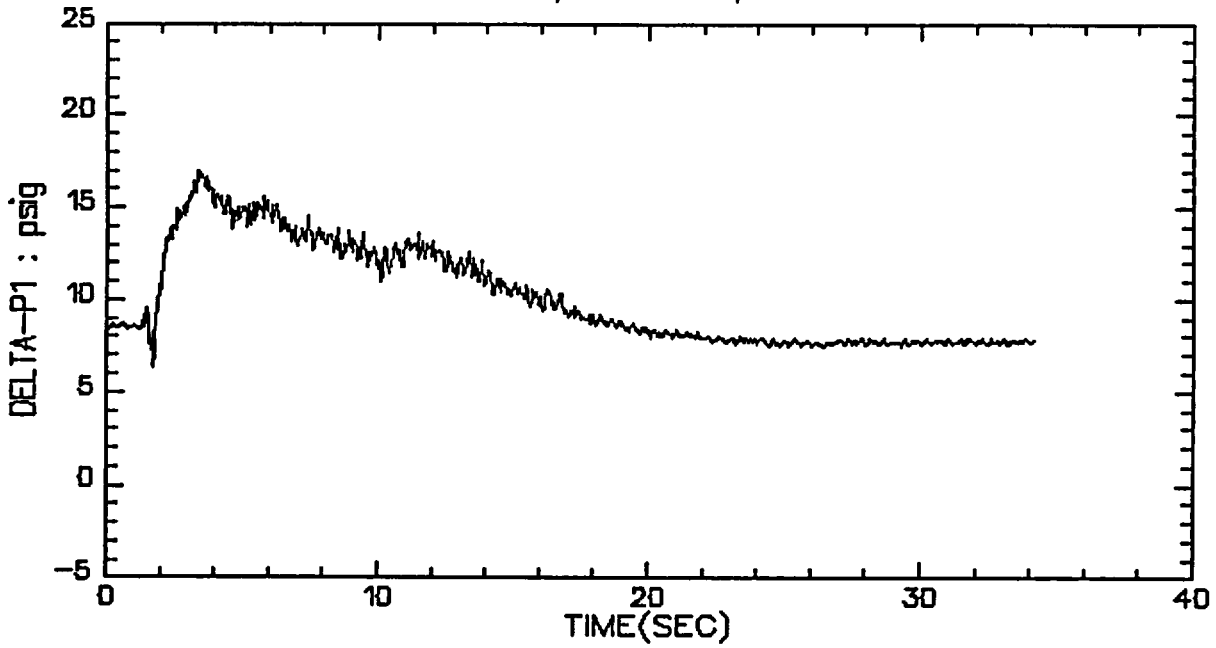

VALVE B, TEST 4, STEP 5

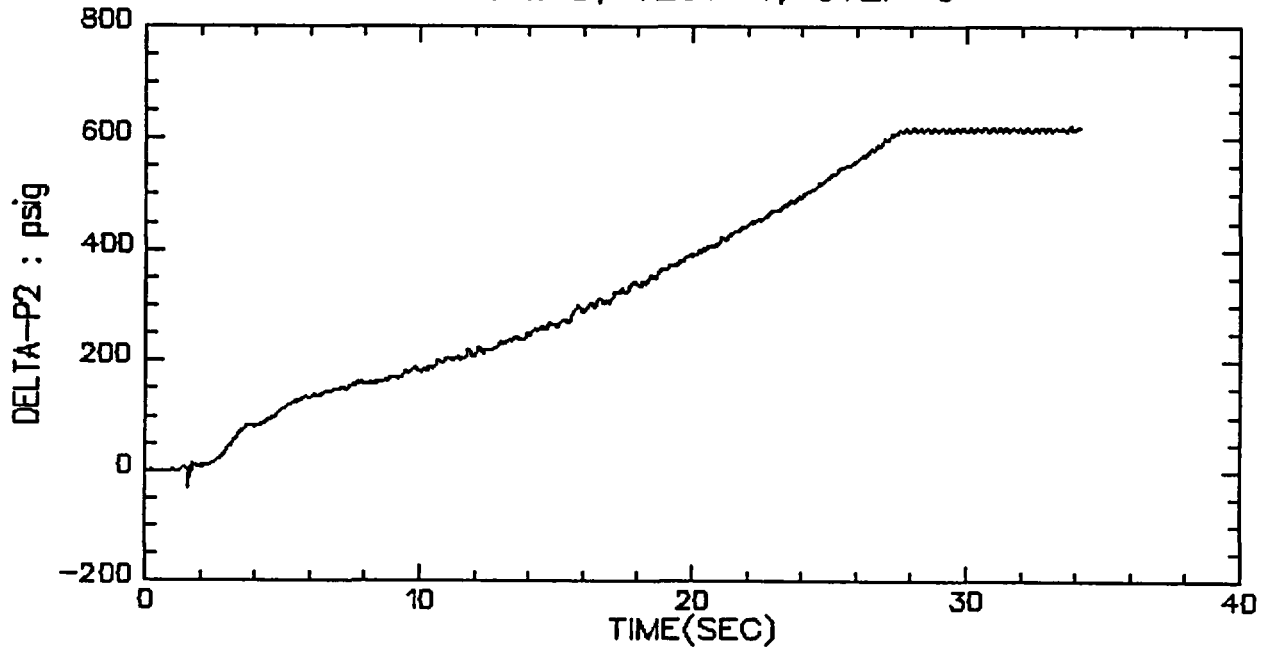

VALVE B, TEST 4, STEP 5

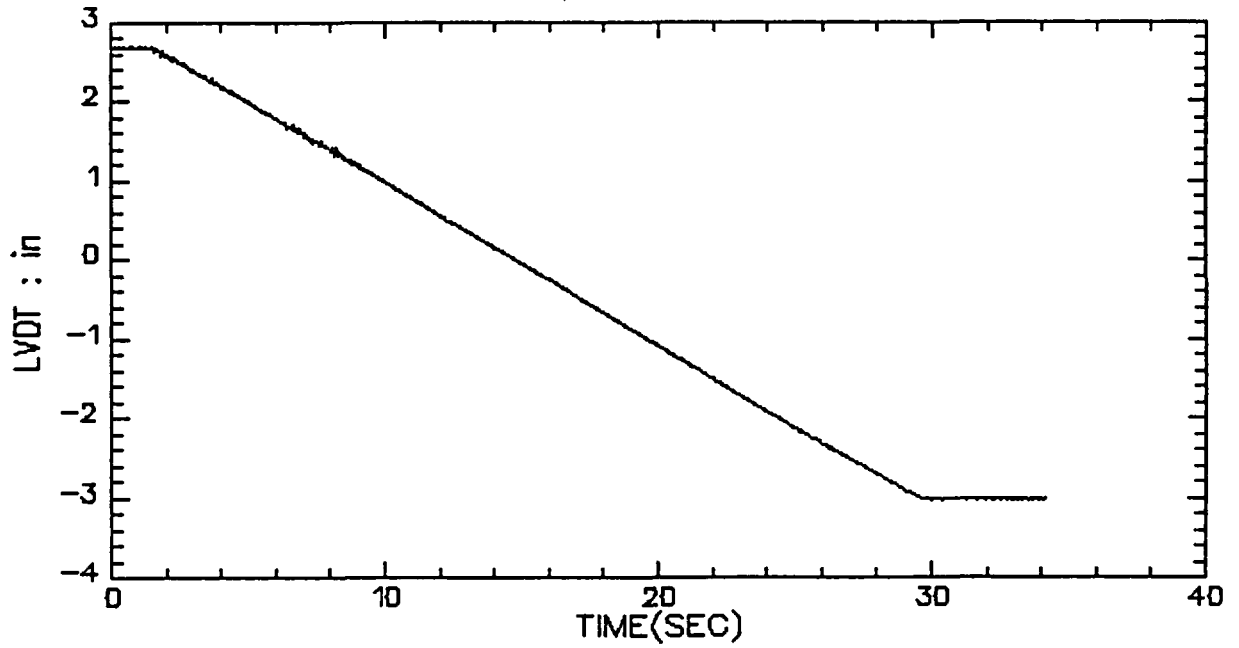

VALVE B, TEST 4, STEP 5

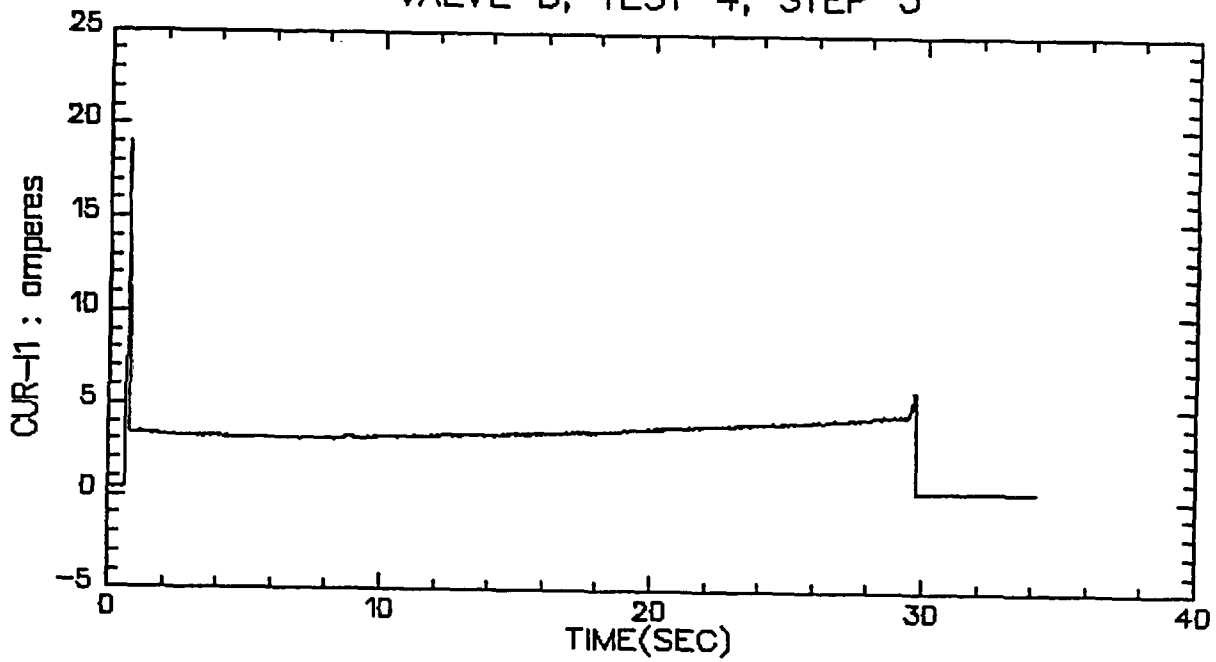

VALVE B, TEST 4, STEP 5

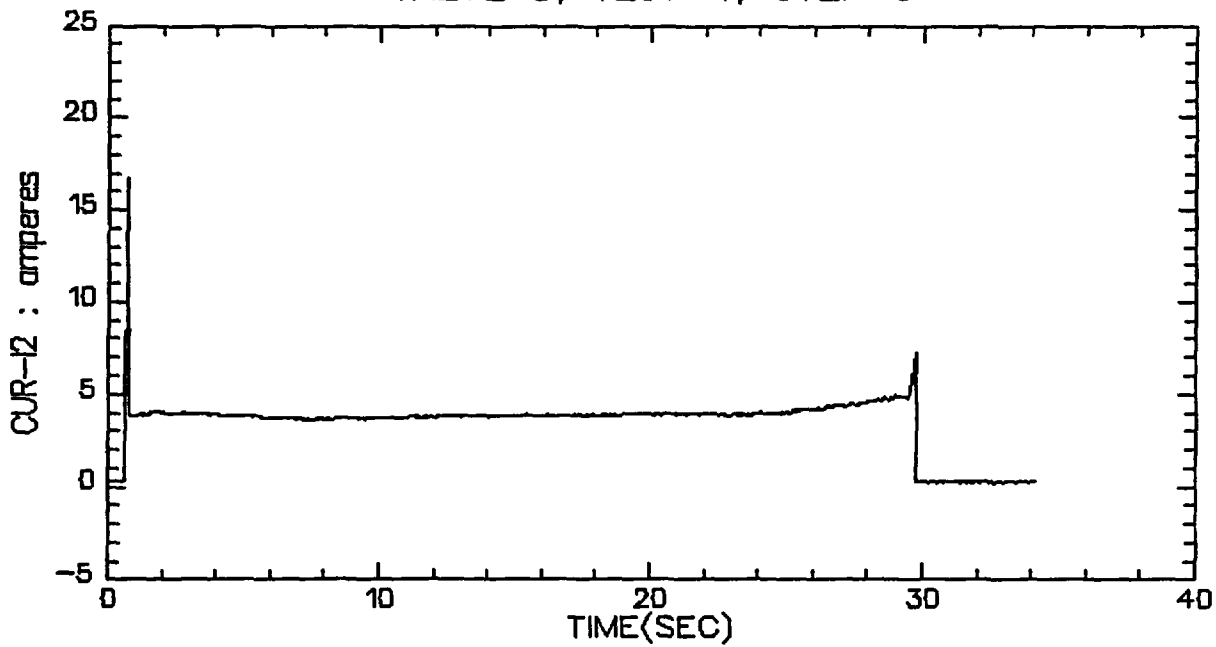

VALVE B, TEST 4, STEP 5

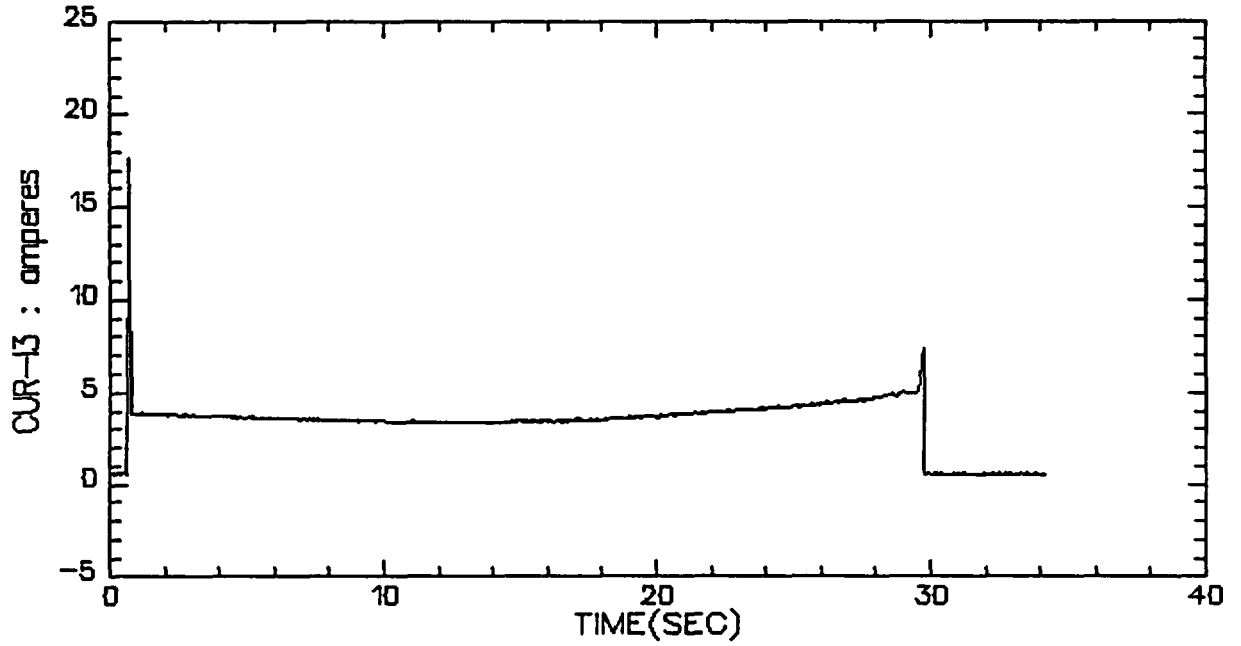

VALVE B, TEST 4, STEP 5

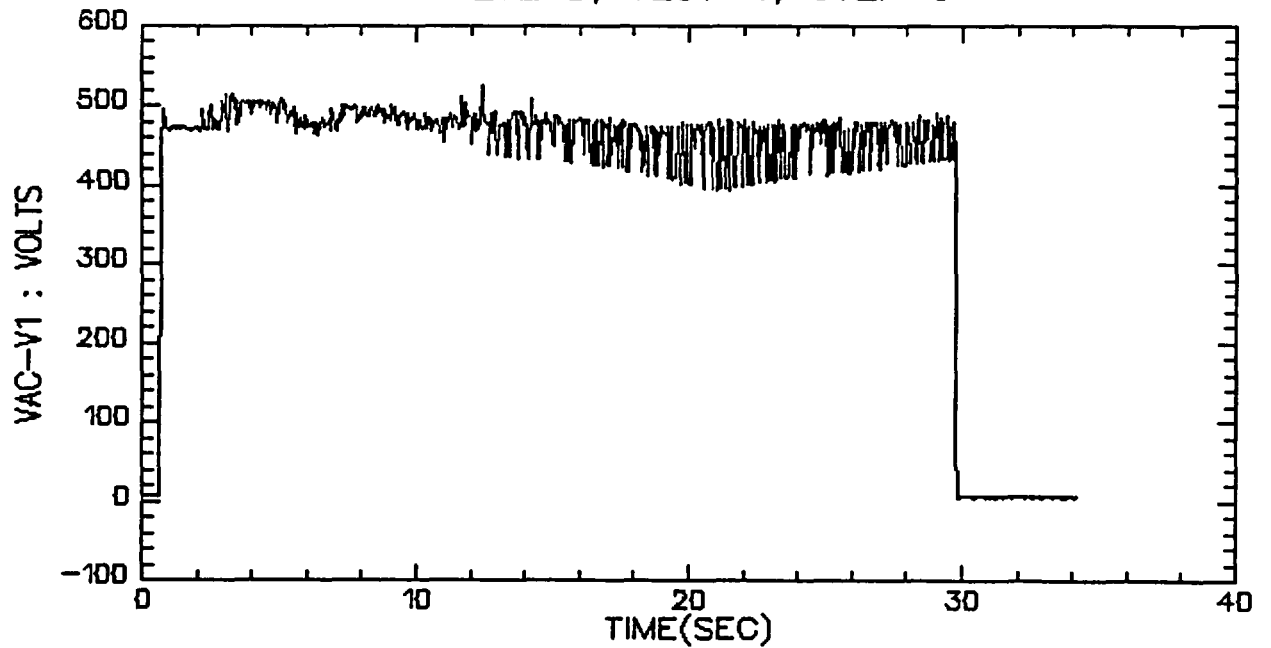

VALVE B, TEST 4, STEP 5

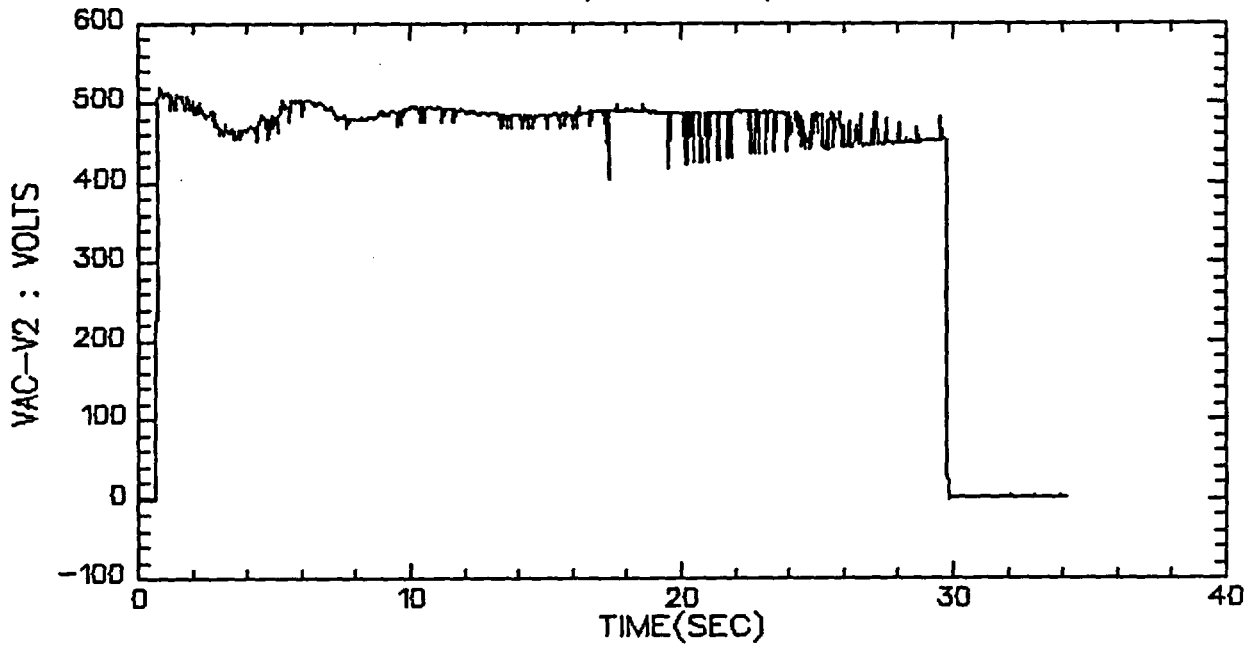

VALVE B, TEST 4, STEP 5

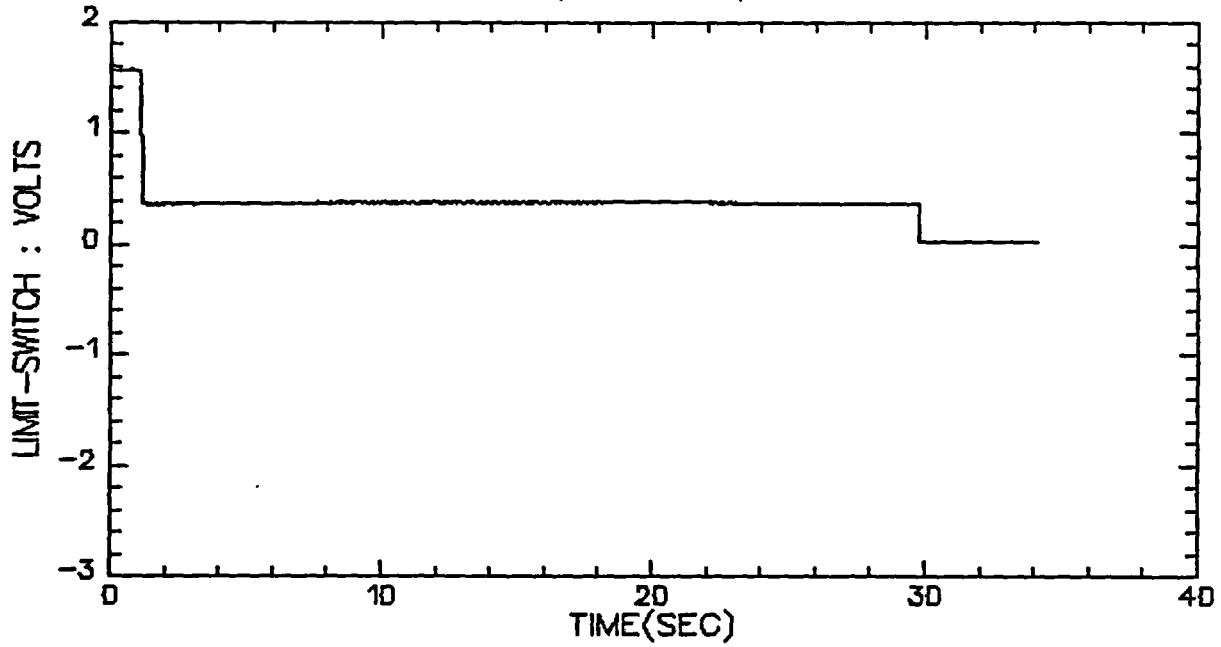

VALVE B, TEST 4, STEP 5

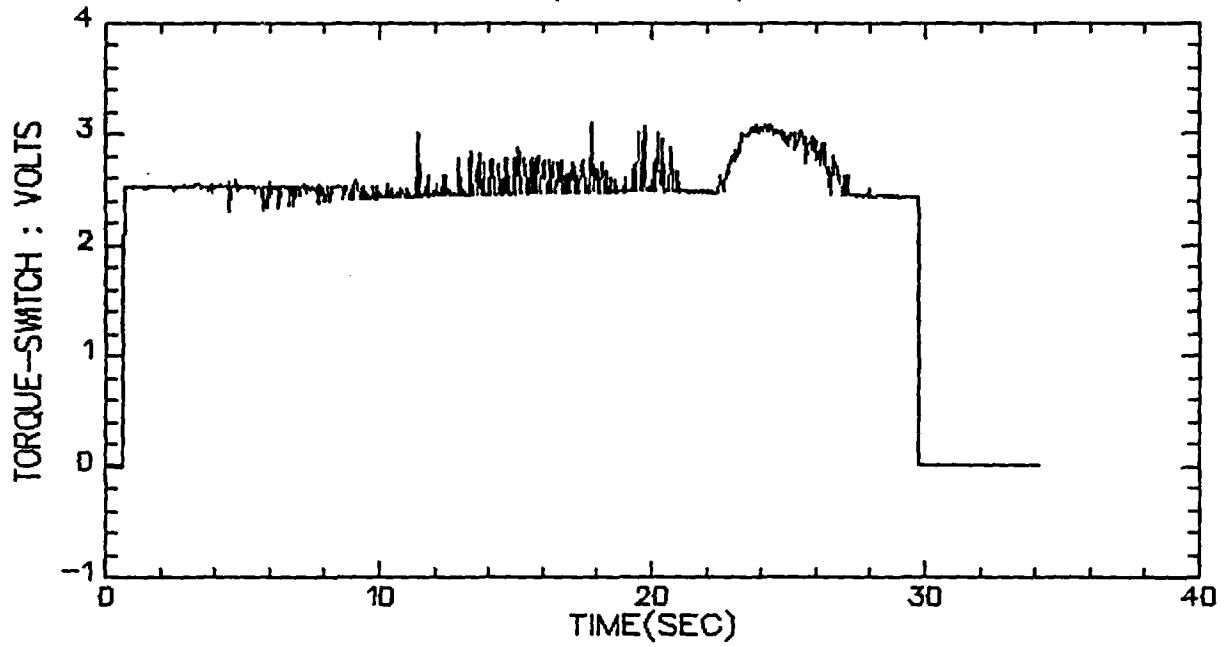

VALVE B, TEST 4, STEP 5

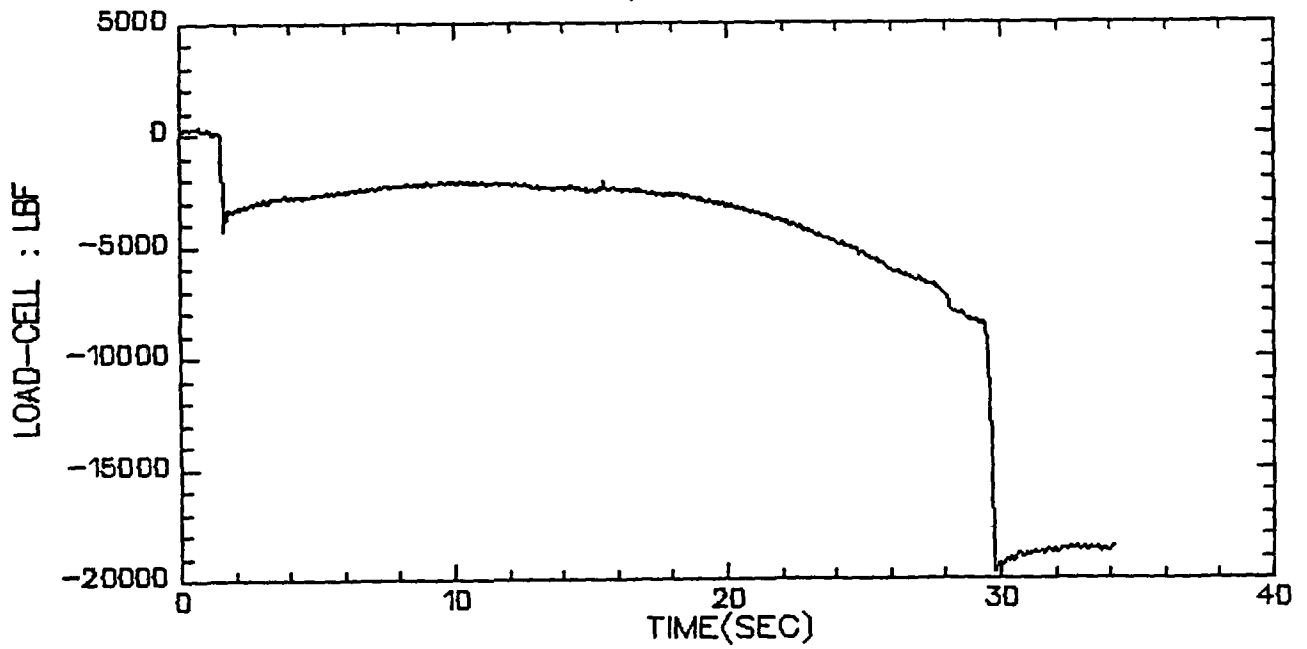

VALVE B, TEST 4, STEP 6&7

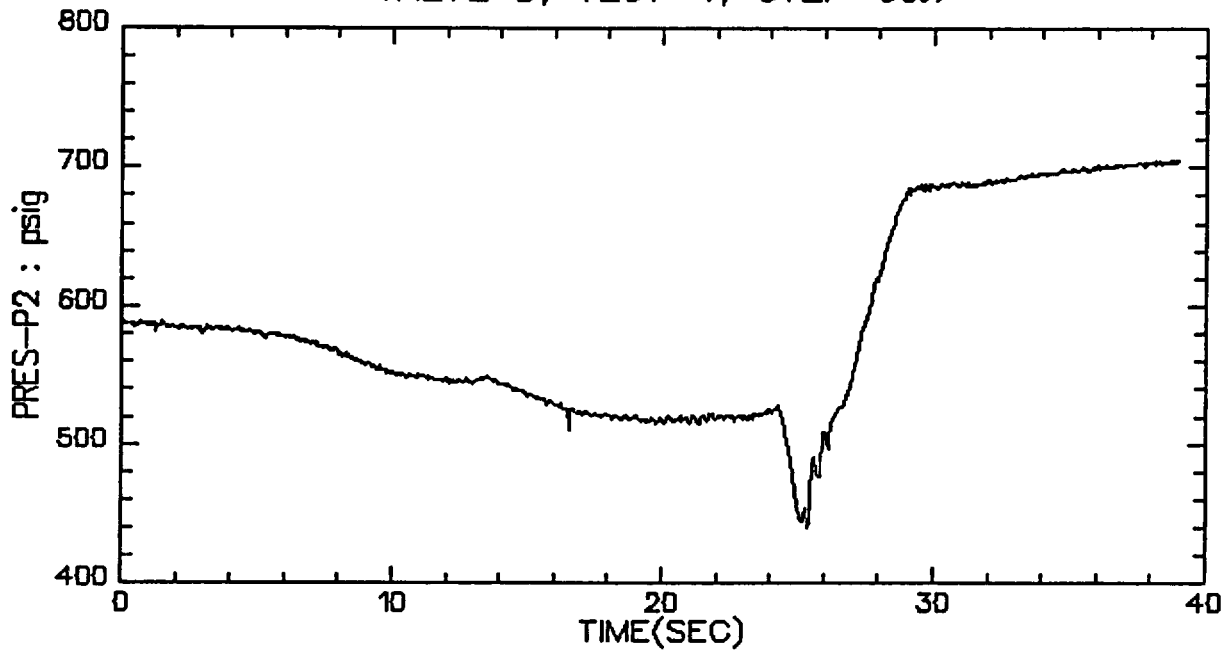

VALVE B, TEST 4, STEP 6&7

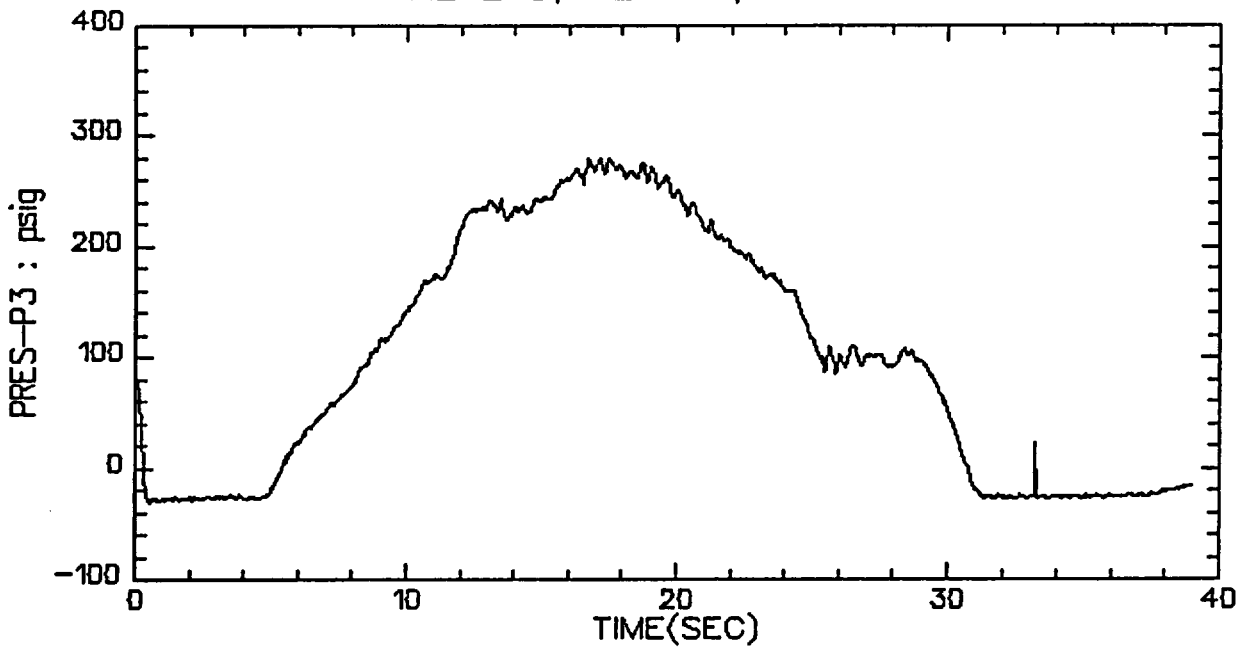

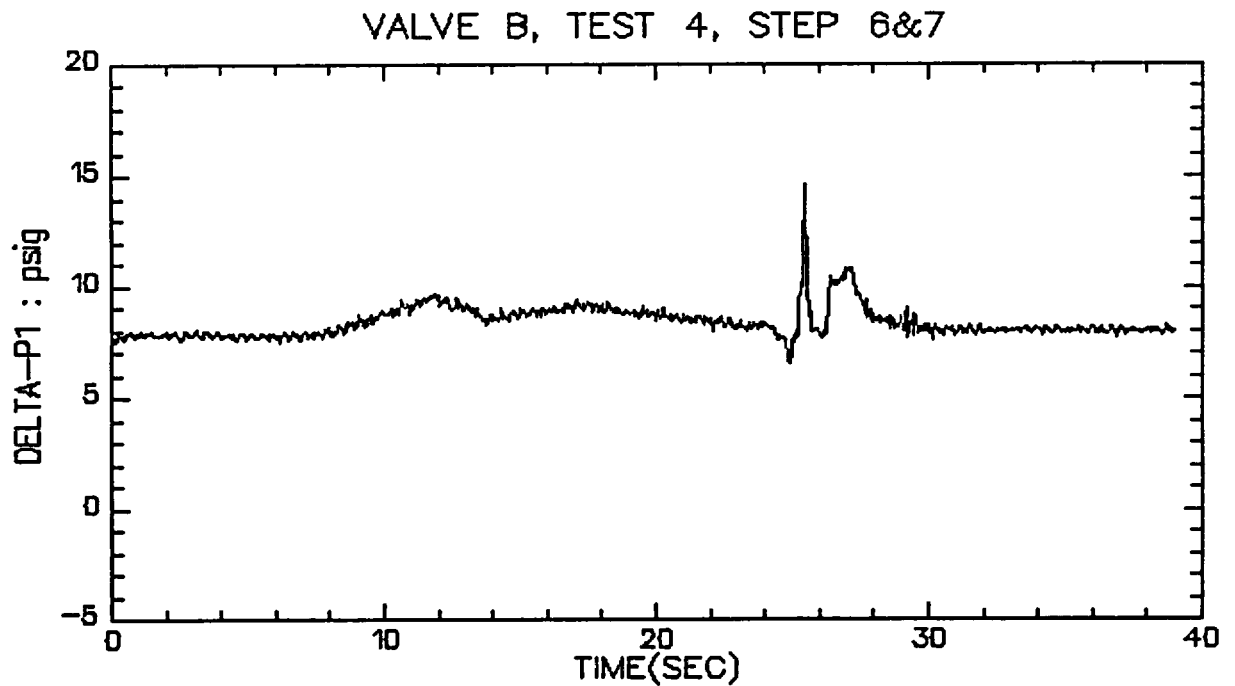
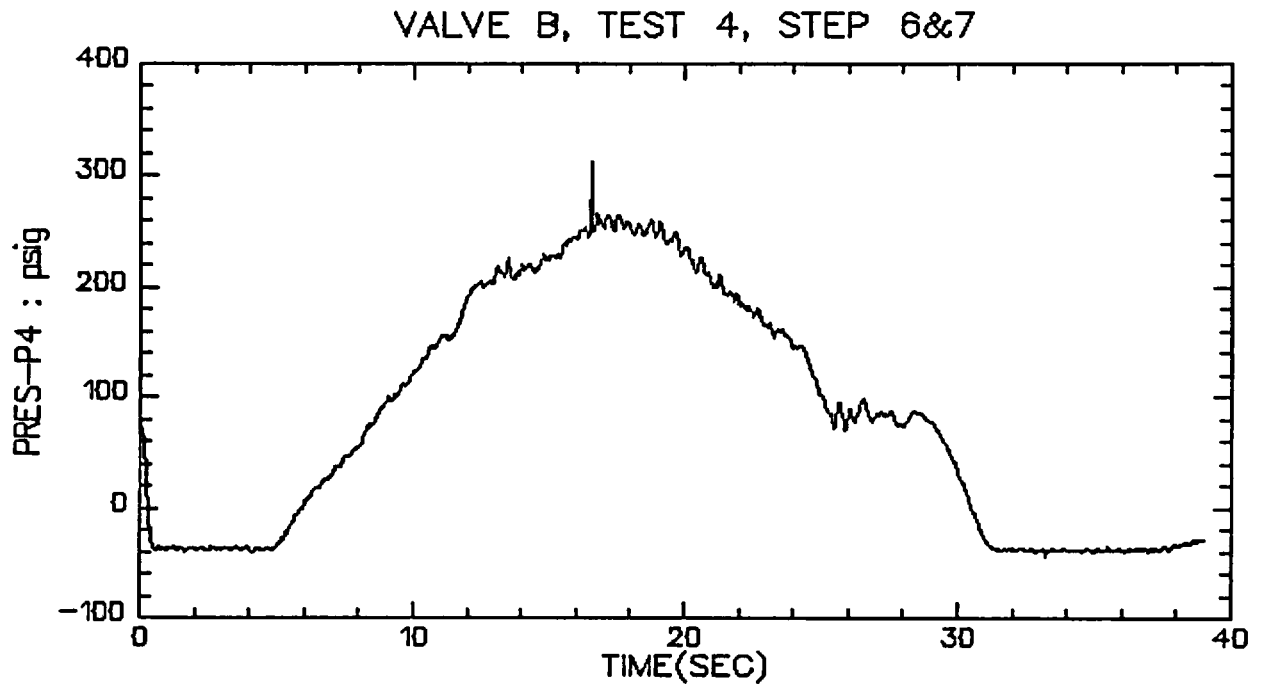

VALVE B, TEST 4, STEP 6&7

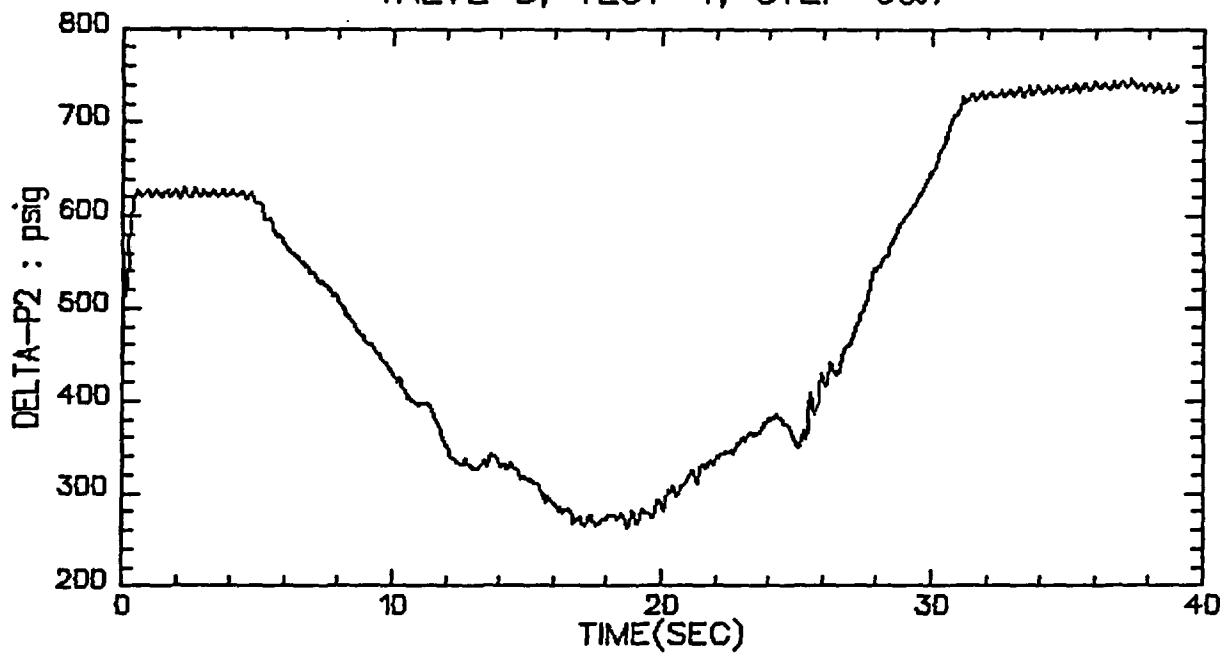

VALVE B, TEST 4, STEP 6&7

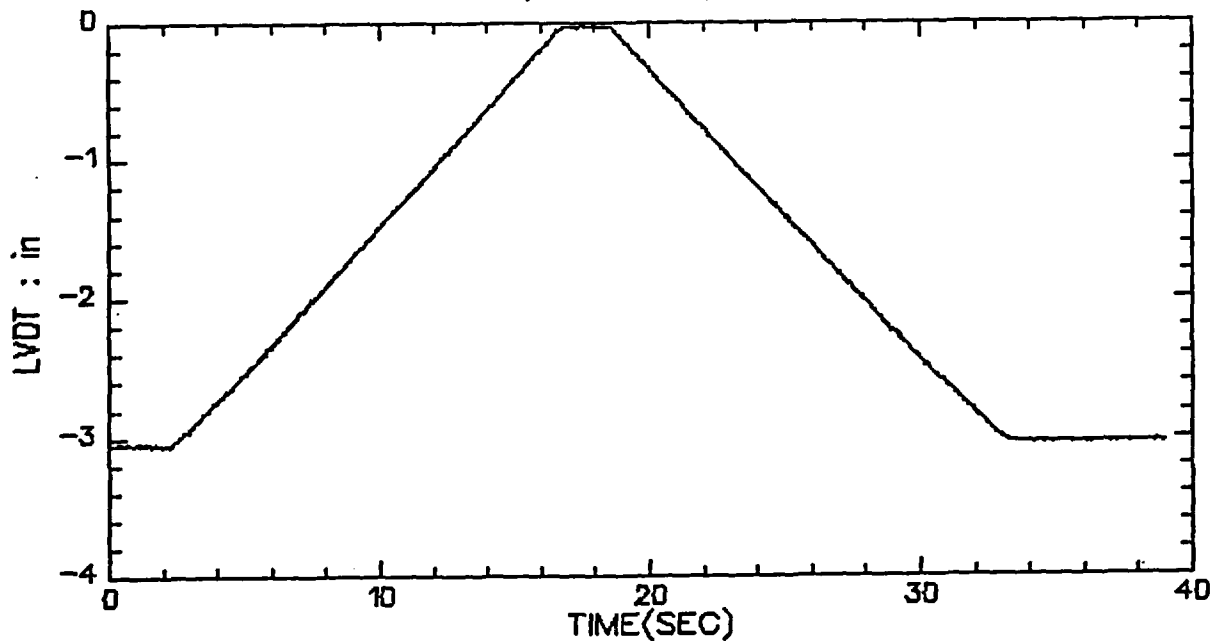

VALVE B, TEST 4, STEP 6&7

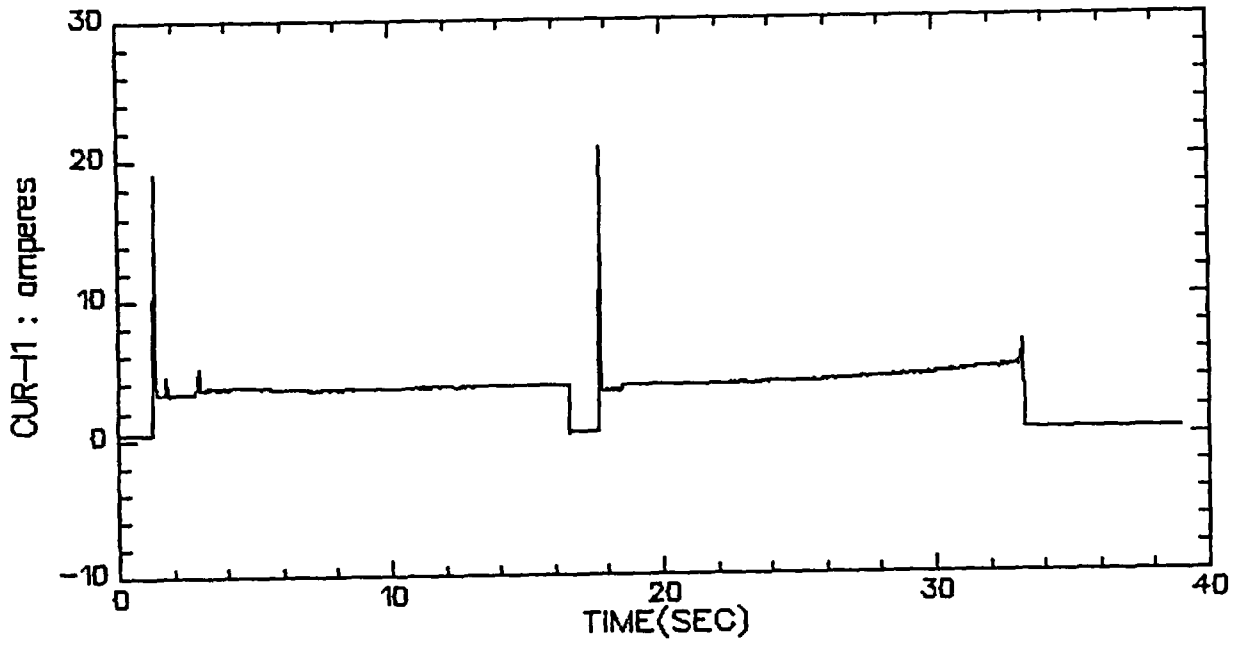

VALVE B, TEST 4, STEP 6&7

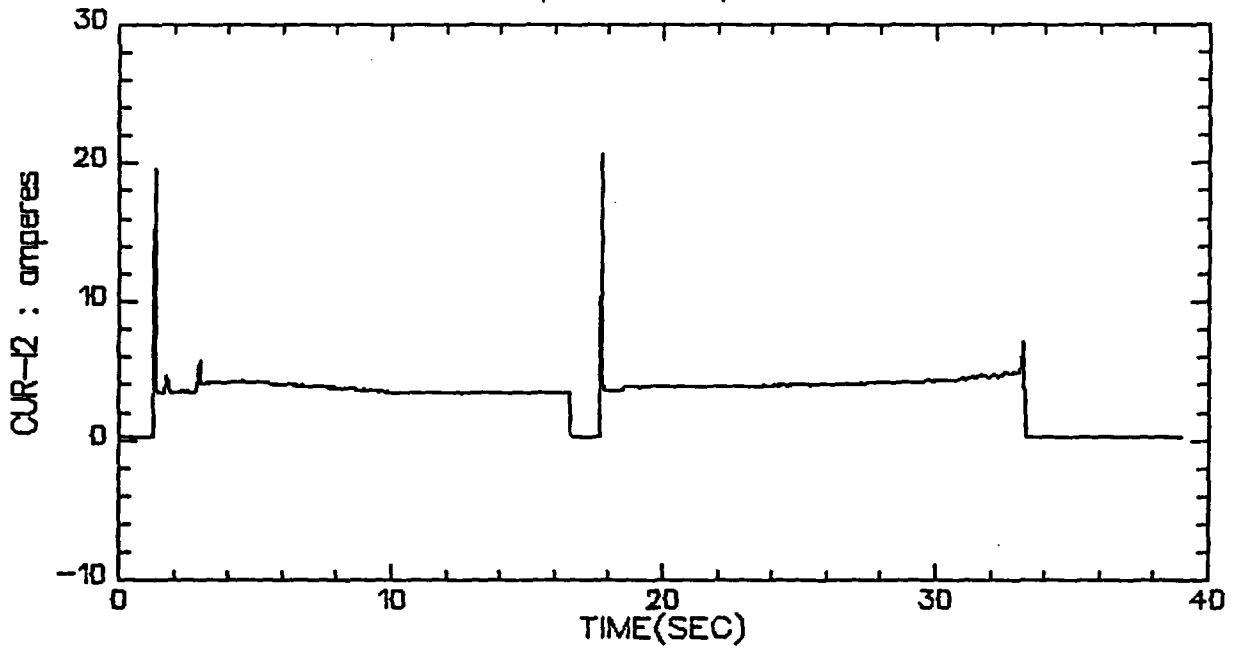

VALVE B, TEST 4, STEP 6&7

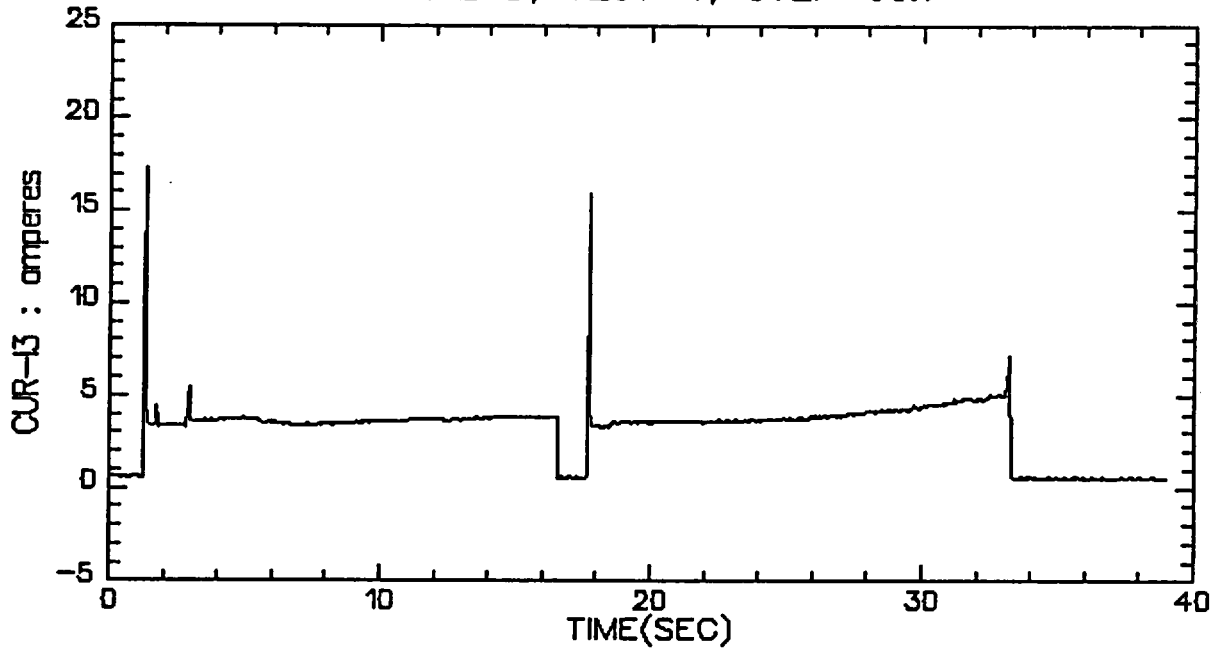

VALVE B, TEST 4, STEP 6&7

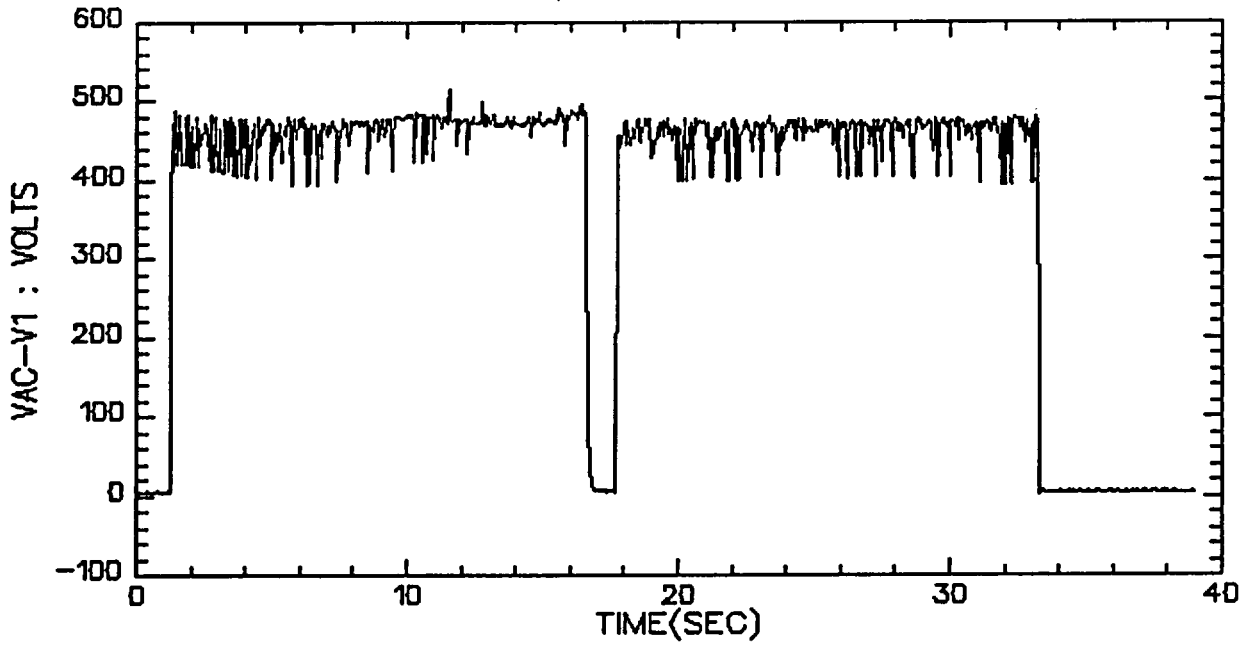

VALVE B, TEST 4, STEP 6&7

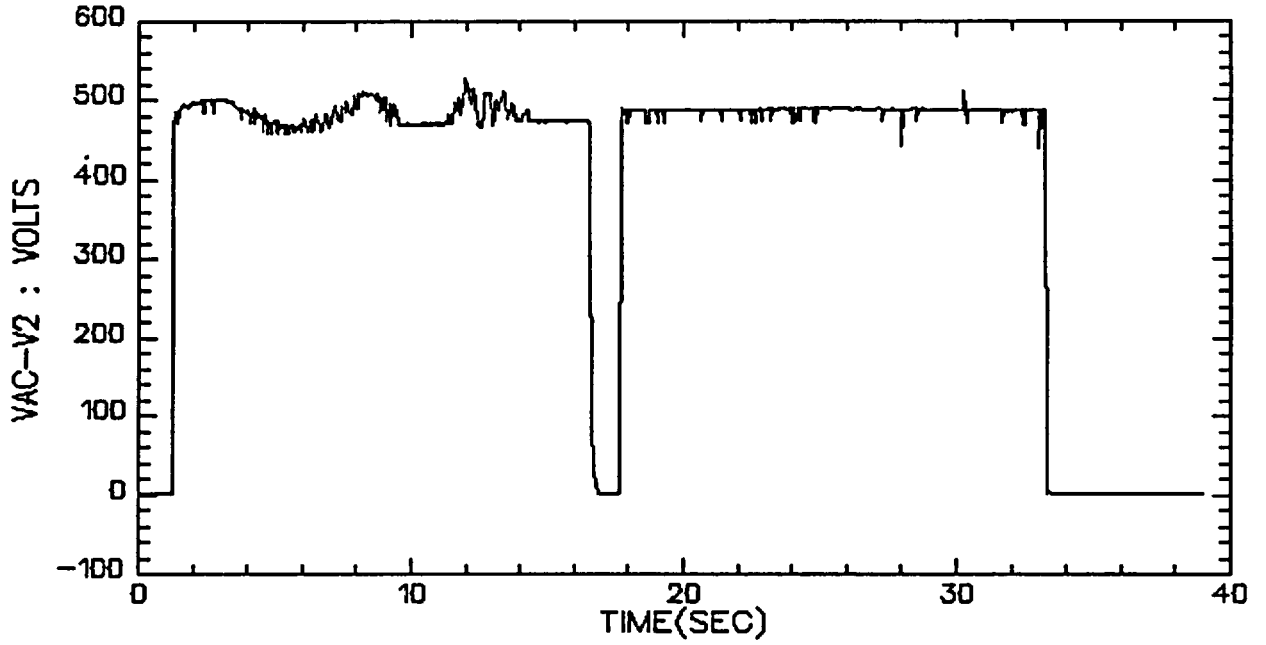

VALVE B, TEST 4, STEP 6&7

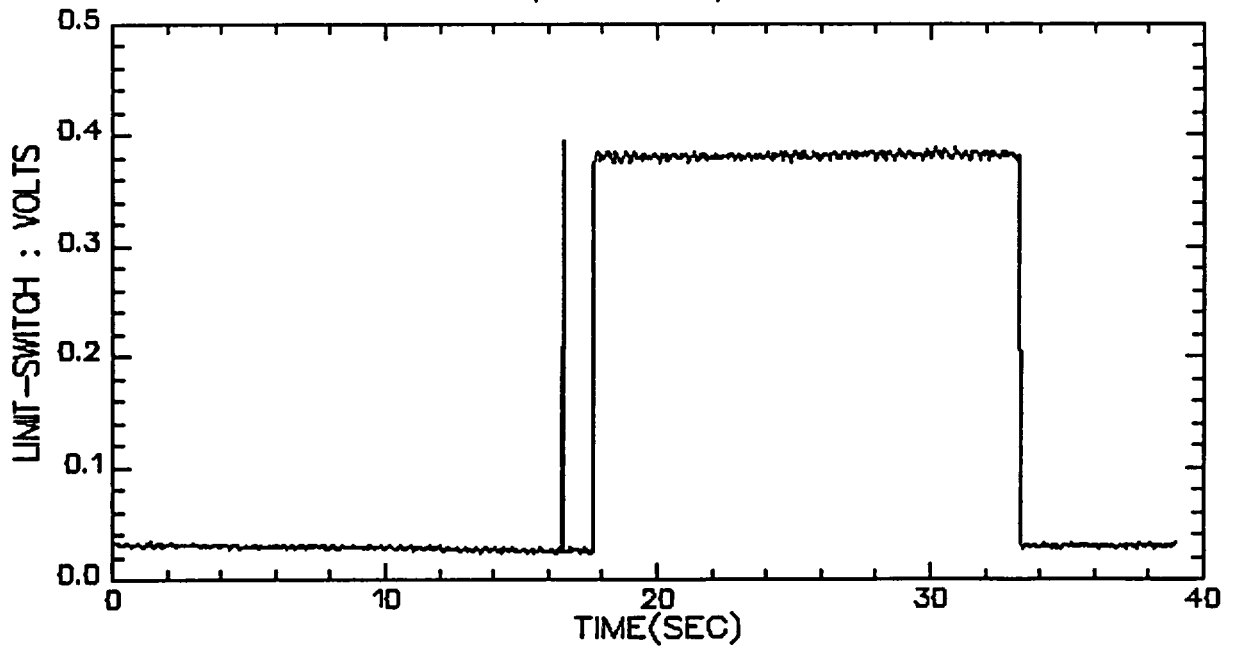

VALVE B, TEST 4, STEP 6&7

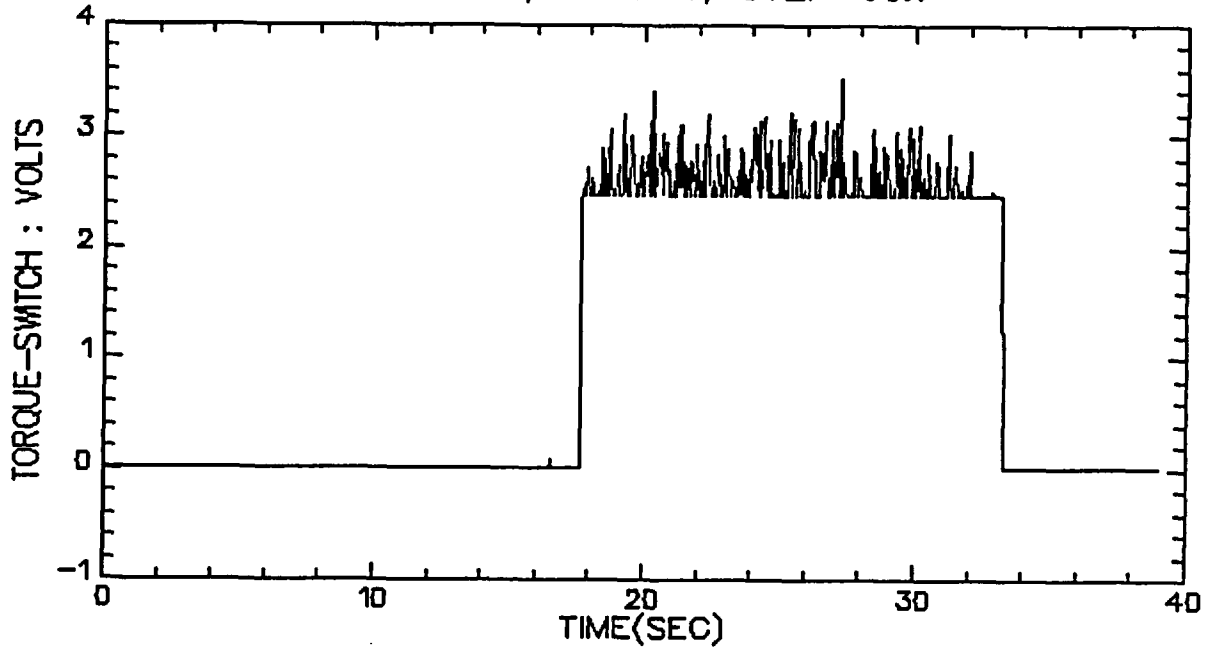

VALVE B, TEST 4, STEP 6&7

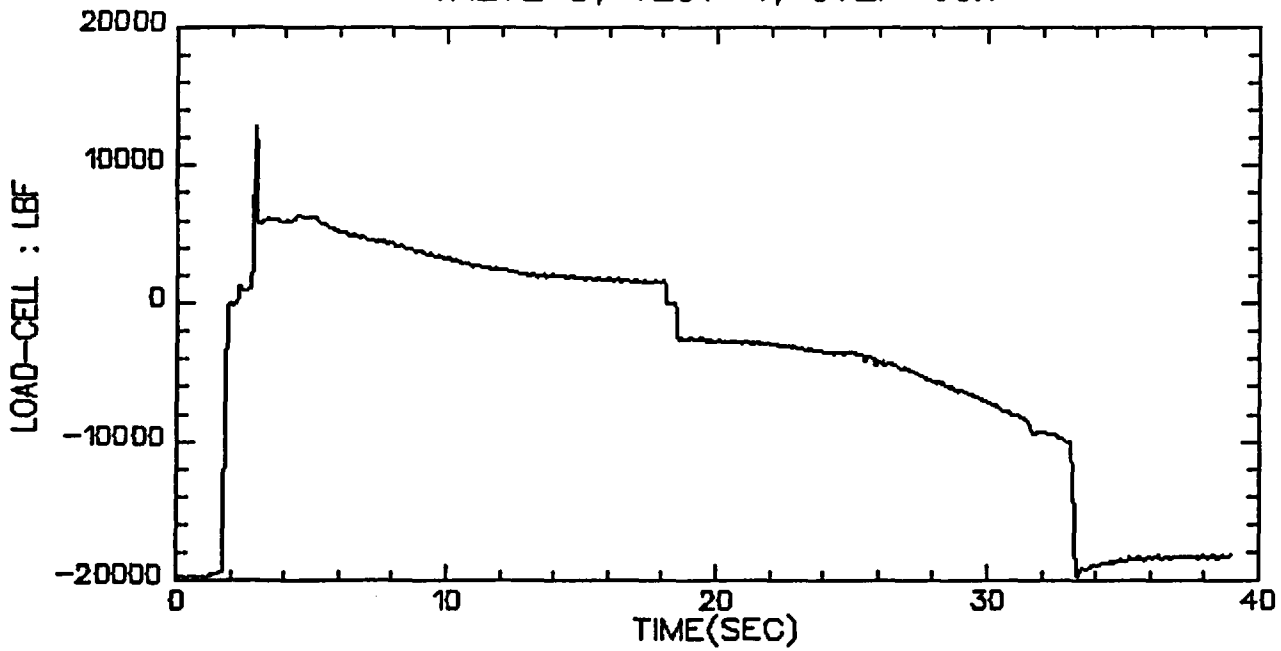

VALVE B, TEST 4, STEP 8&9

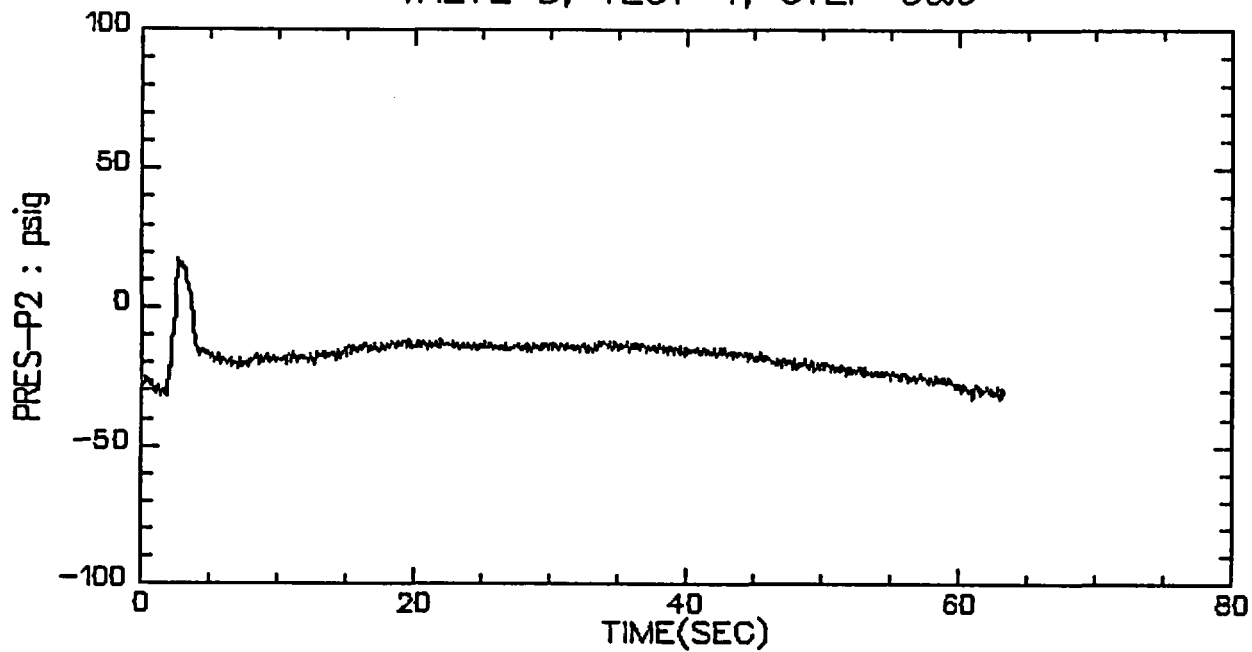

VALVE B, TEST 4, STEP 8&9

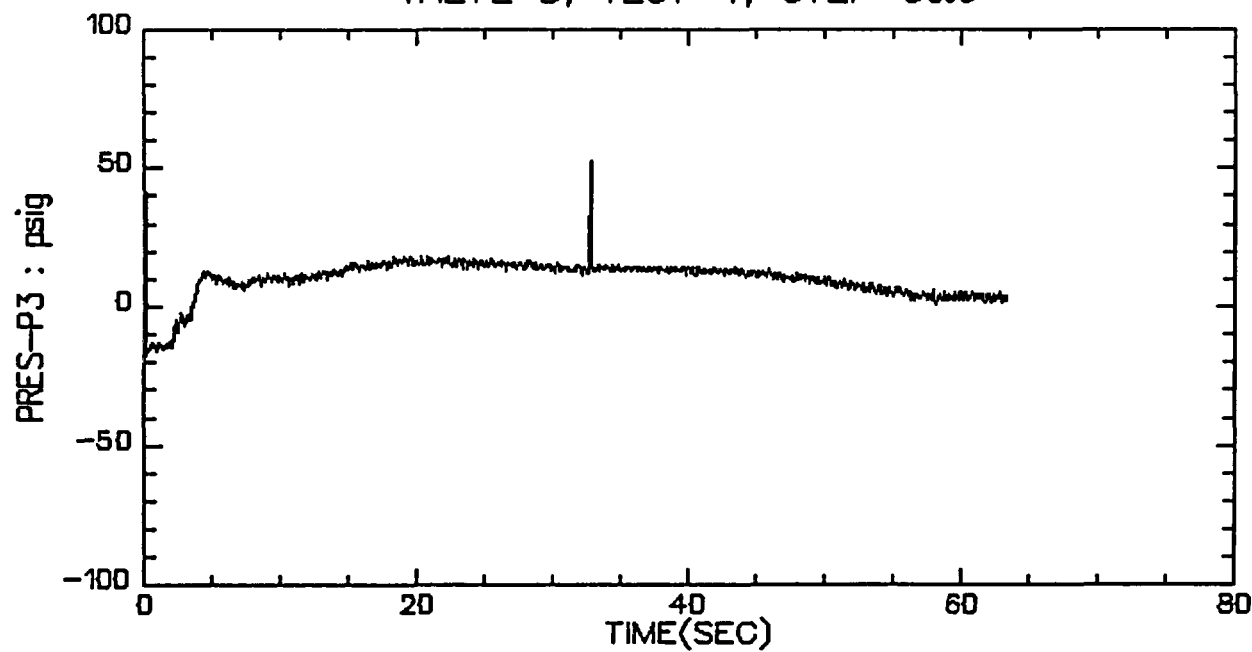

VALVE B, TEST 4, STEP 8&9

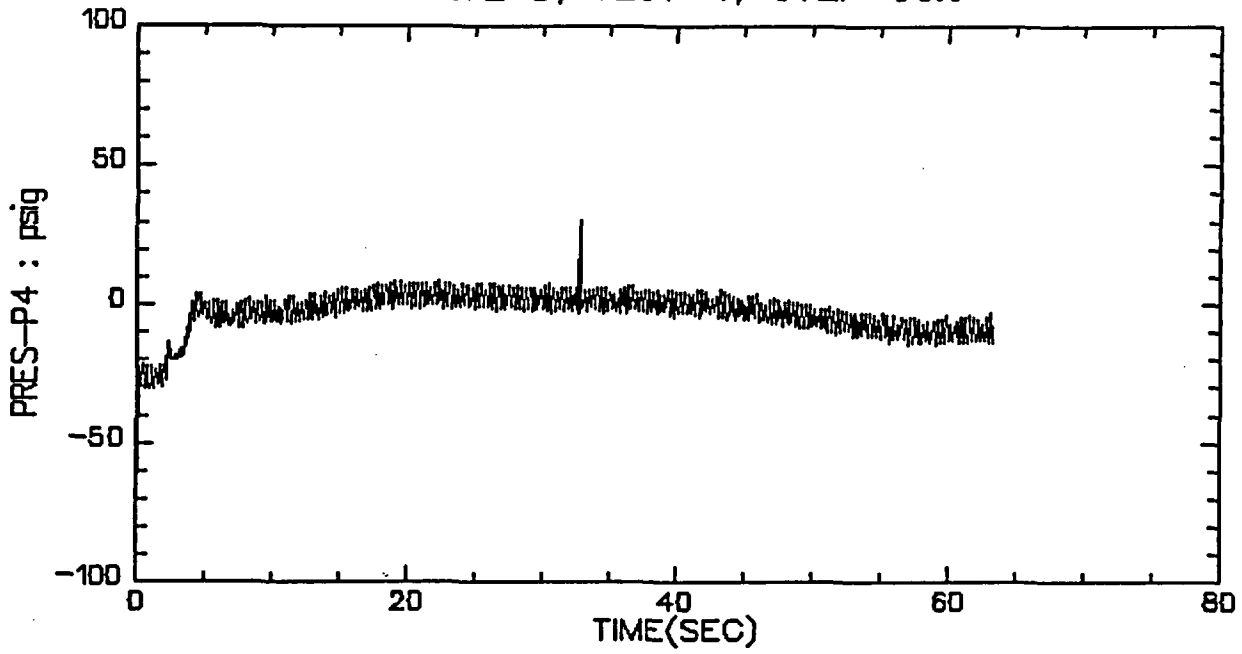

VALVE B, TEST 4, STEP 8&9

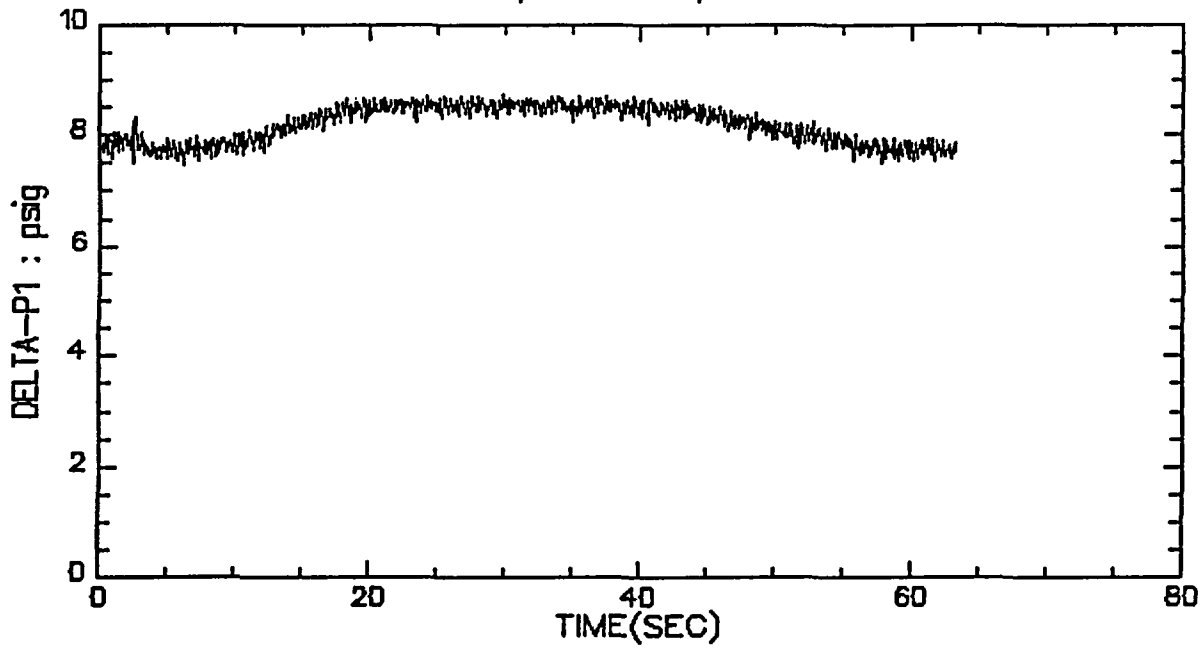

VALVE B, TEST 4, STEP 8&9

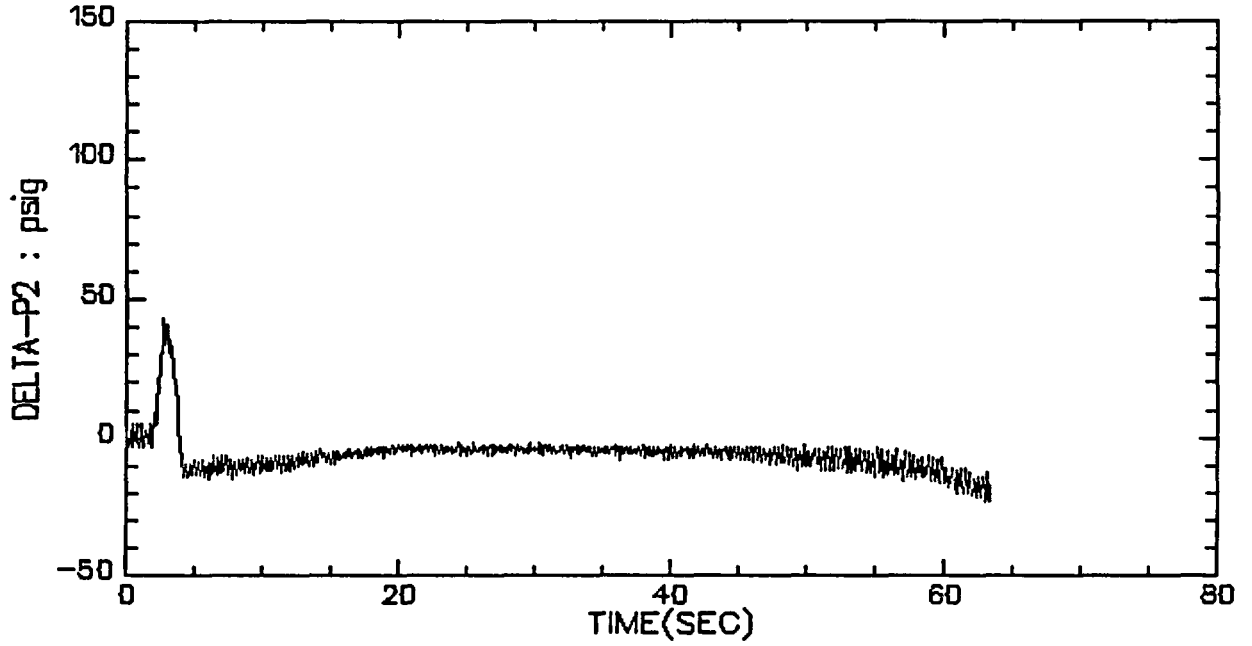

VALVE B, TEST 4, STEP 8&9

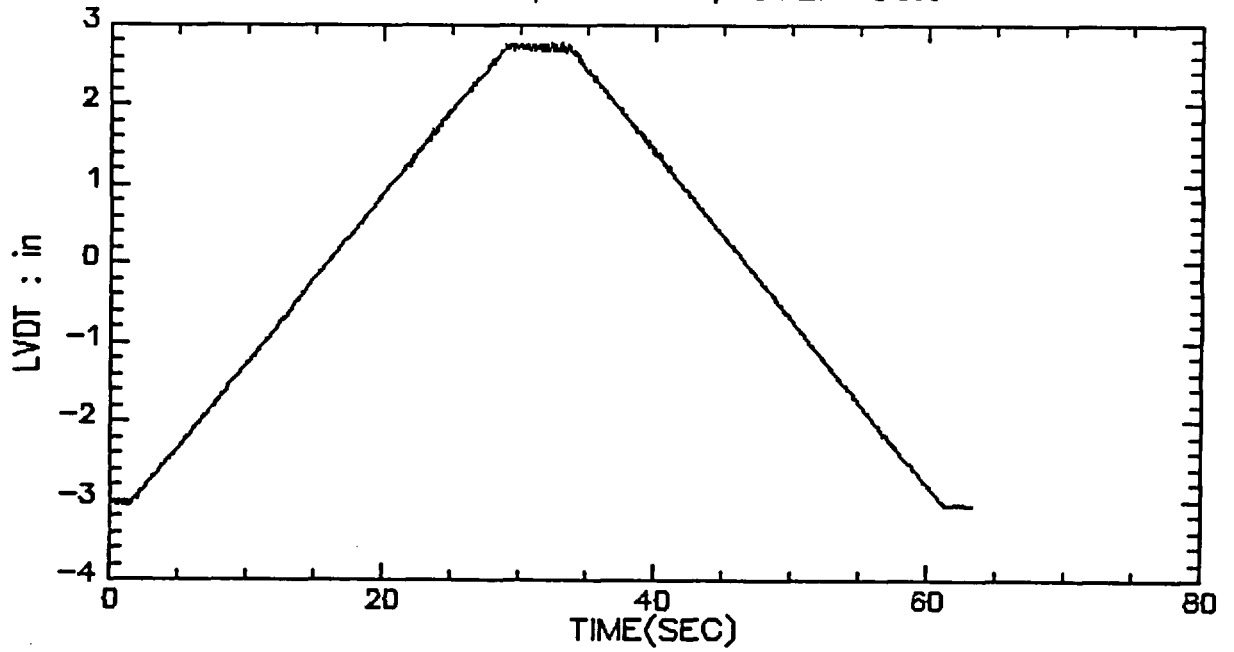

VALVE B, TEST 4, STEP 8&9

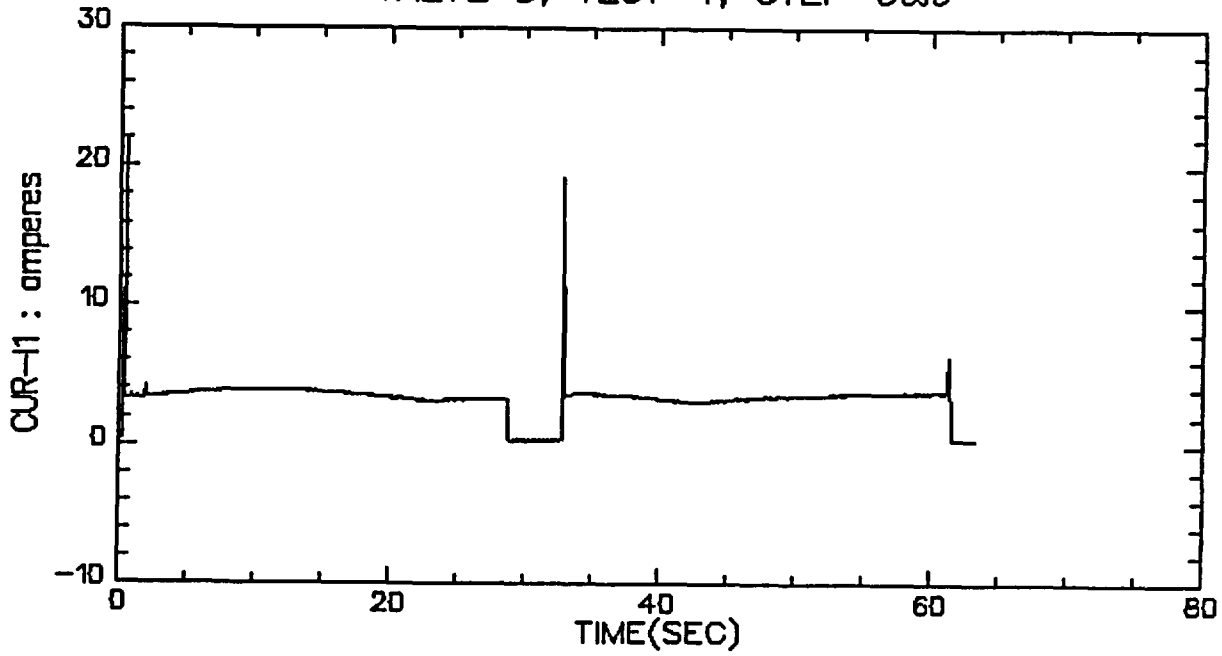

VALVE B, TEST 4, STEP 8&9

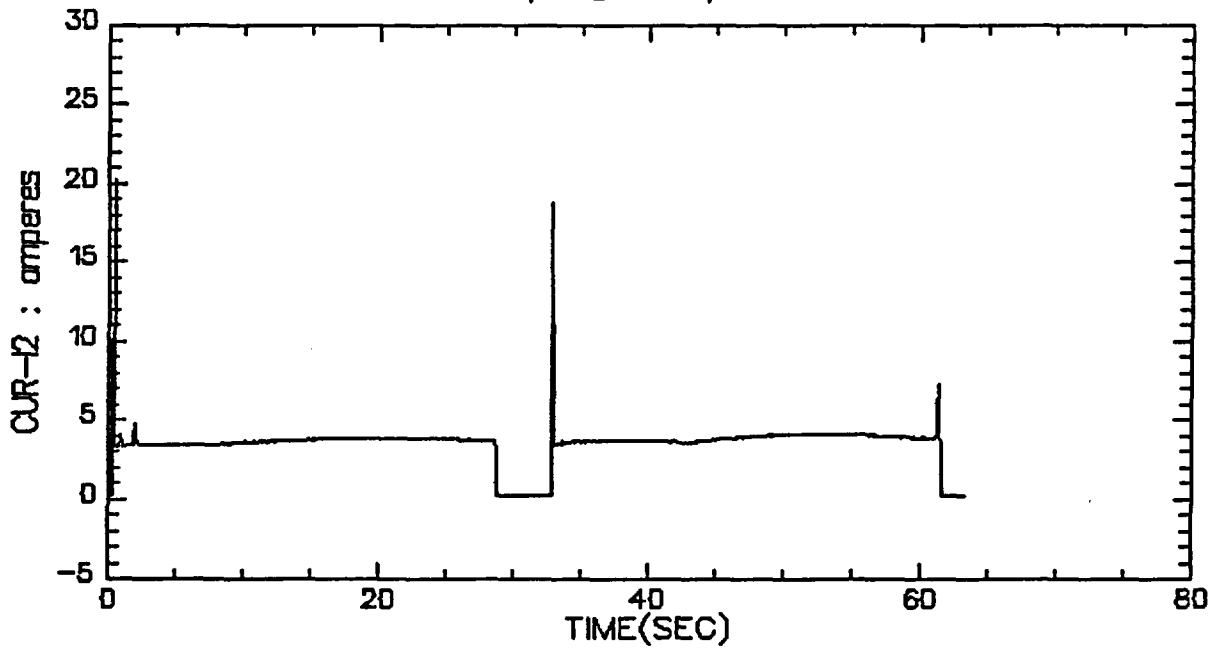

VALVE B, TEST 4, STEP 8&9

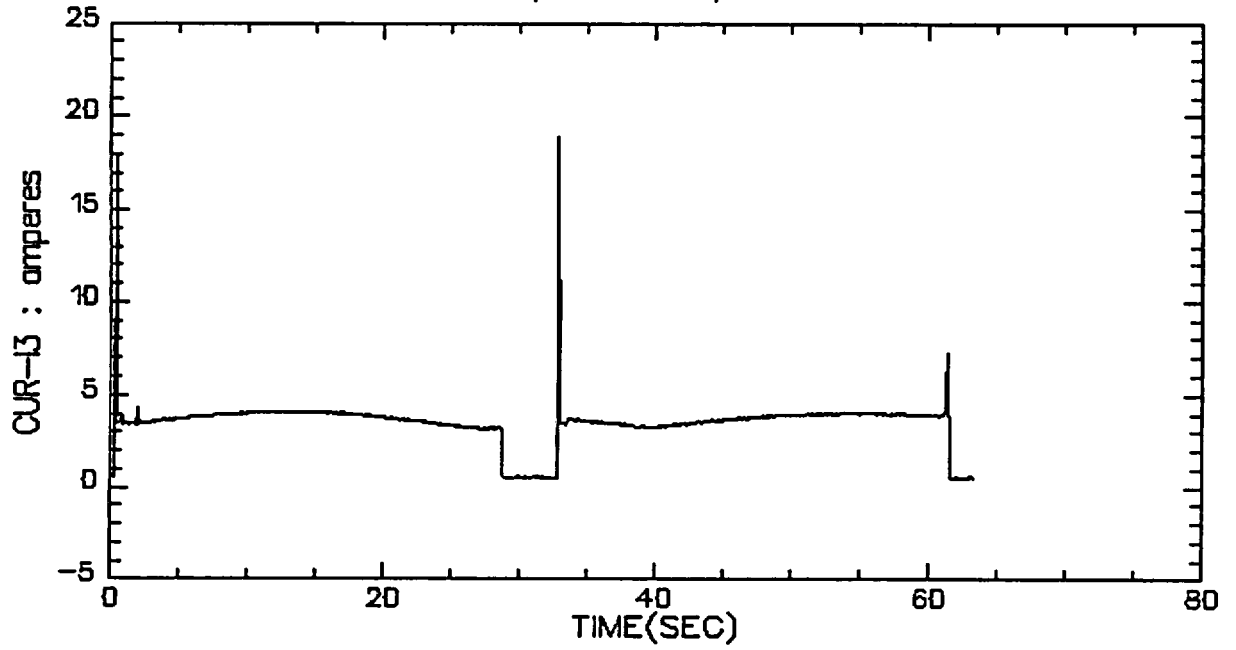

VALVE B, TEST 4, STEP 8&9

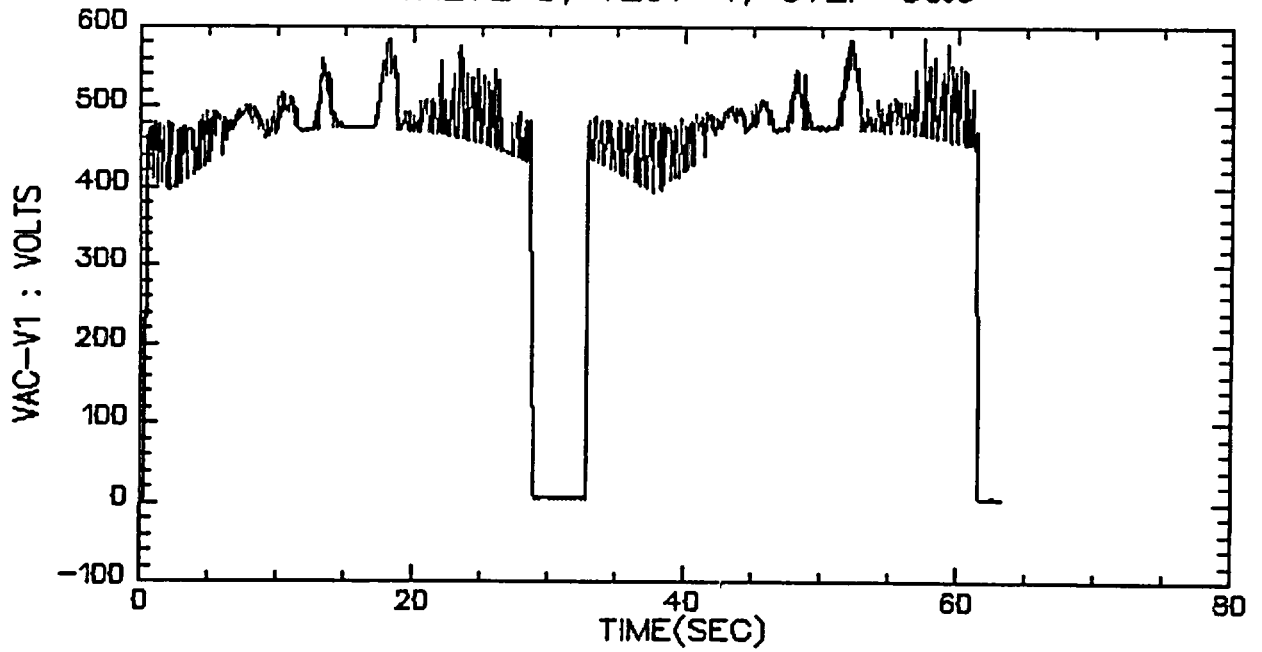

VALVE B, TEST 4, STEP 8&9

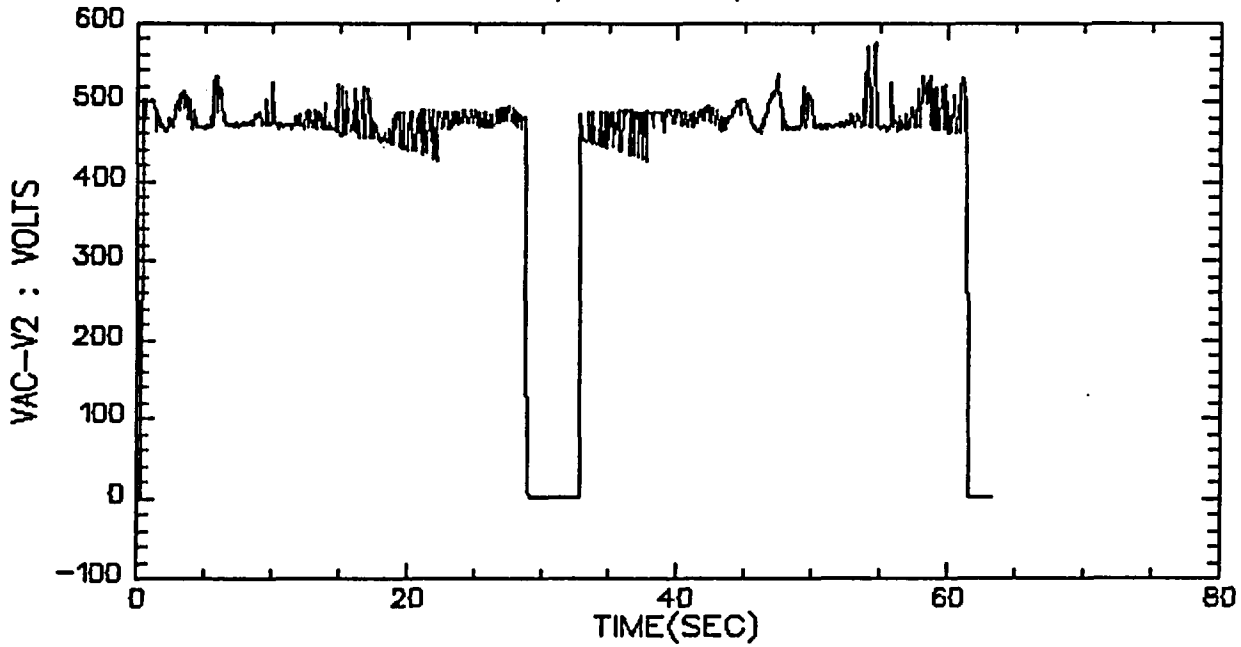

VALVE B, TEST 4, STEP 8&9

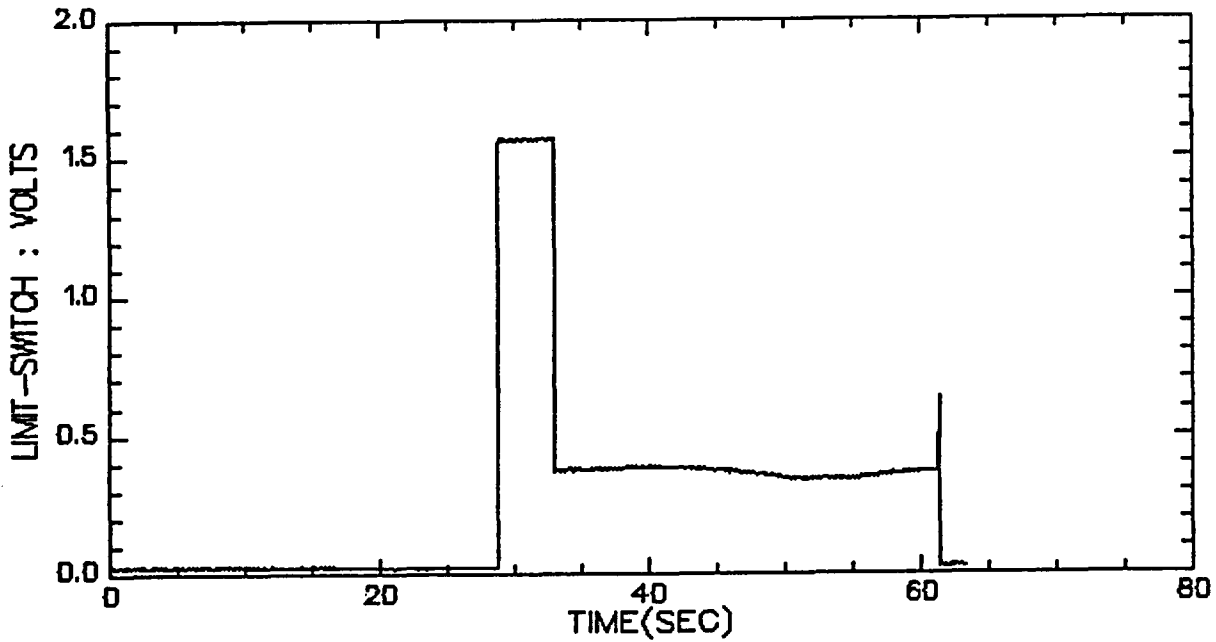

VALVE B, TEST 4, STEP 8&9

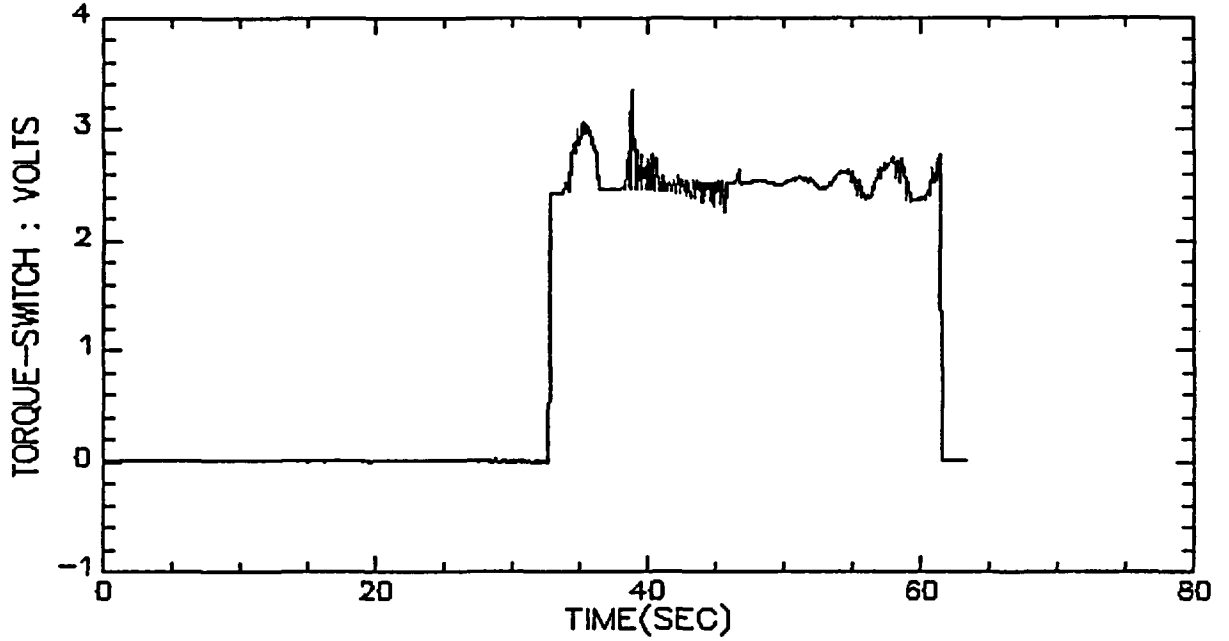

VALVE B, TEST 4, STEP 8&9

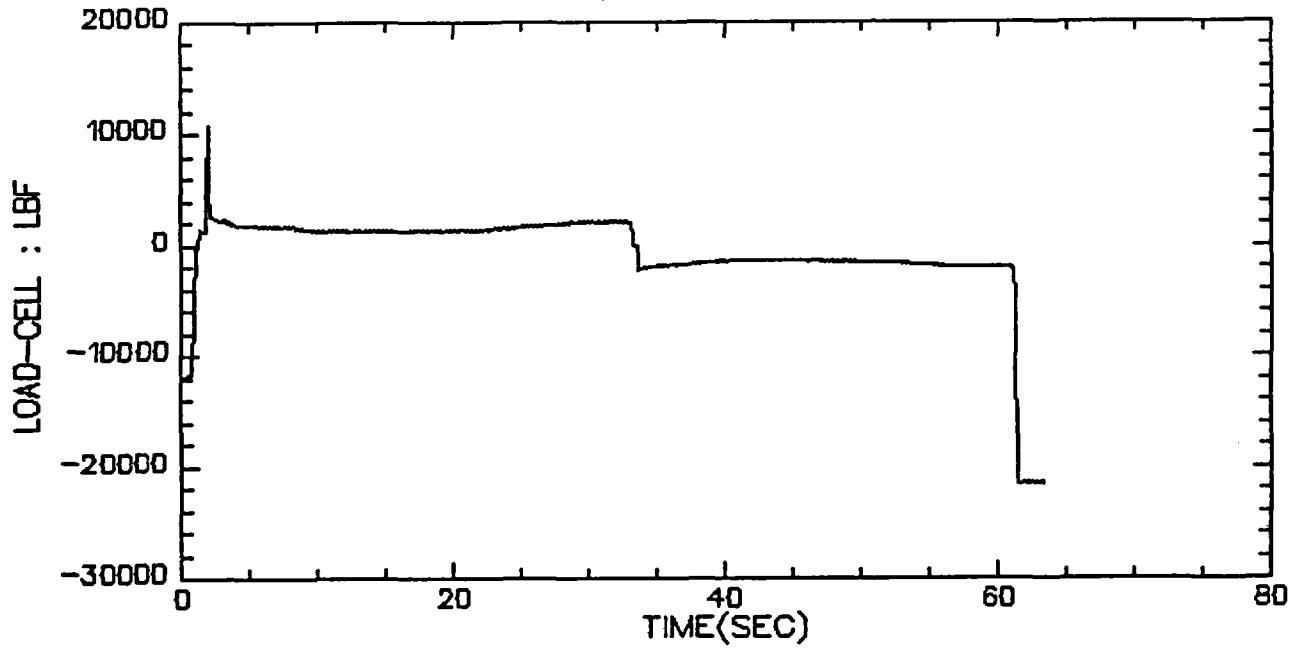

VALVE B, TEST 5, STEP 1

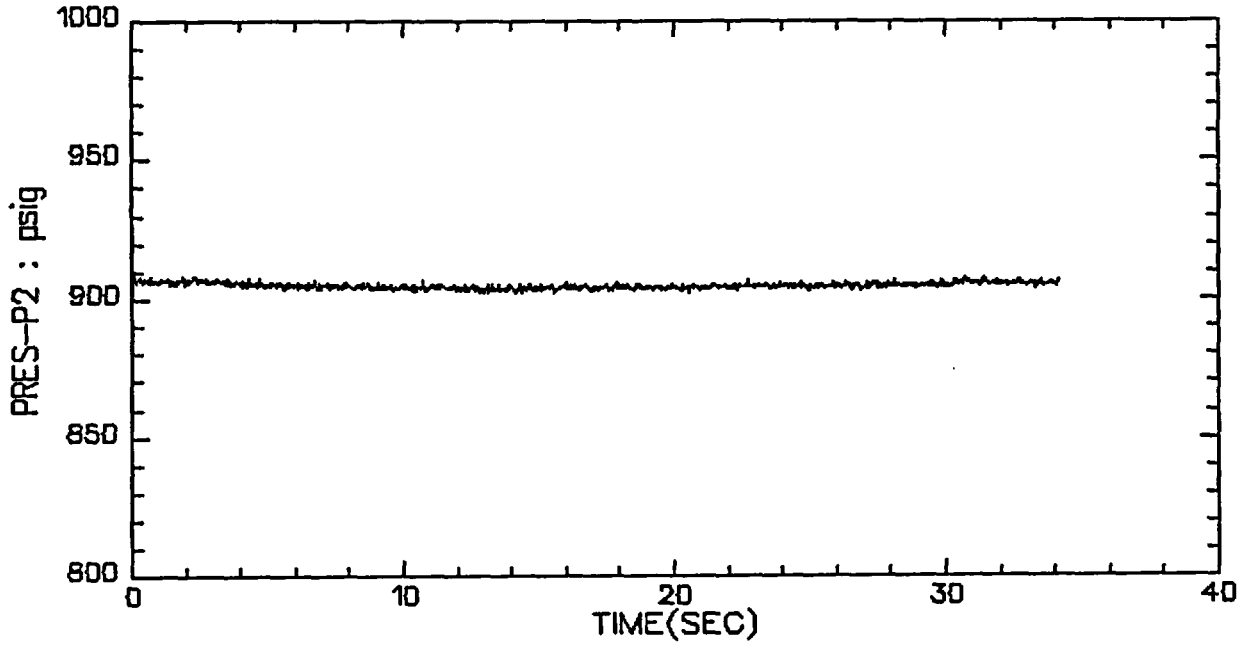

VALVE B, TEST 5, STEP 1

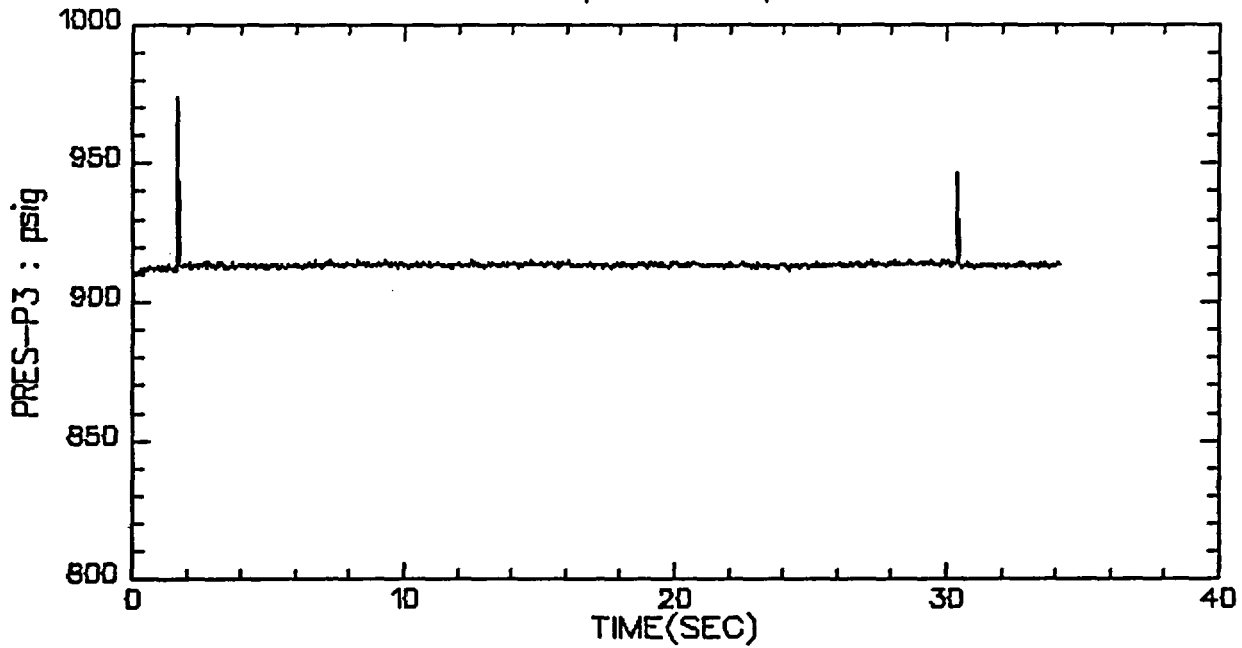

VALVE B, TEST 5, STEP 1

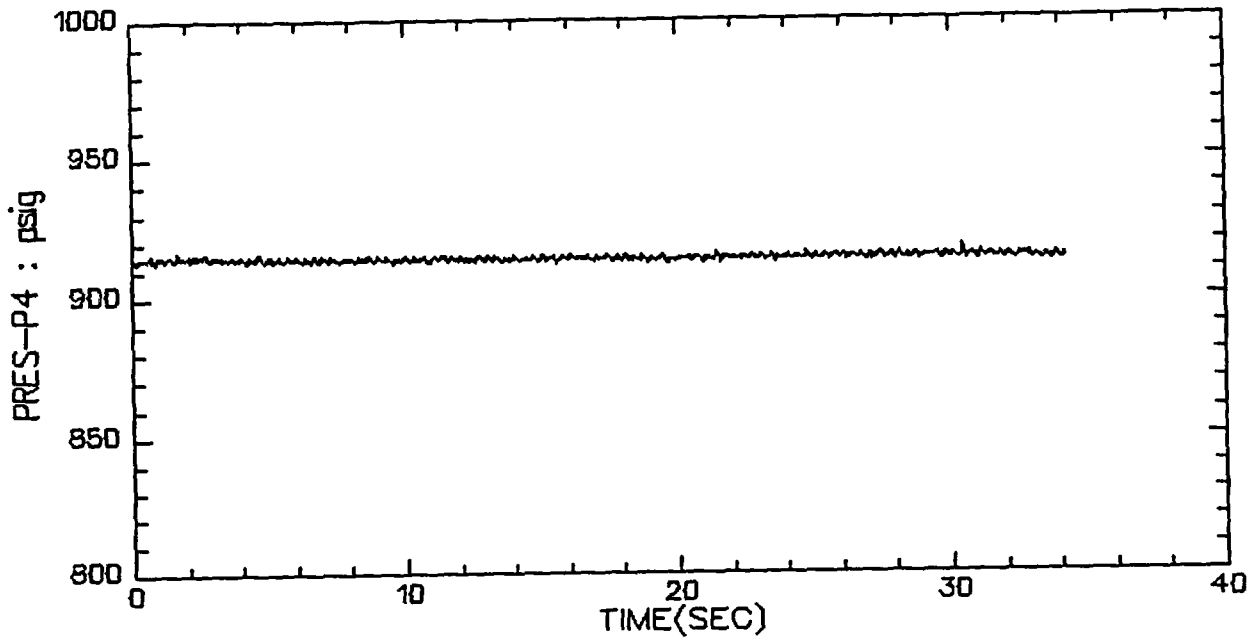

VALVE B, TEST 5, STEP 1

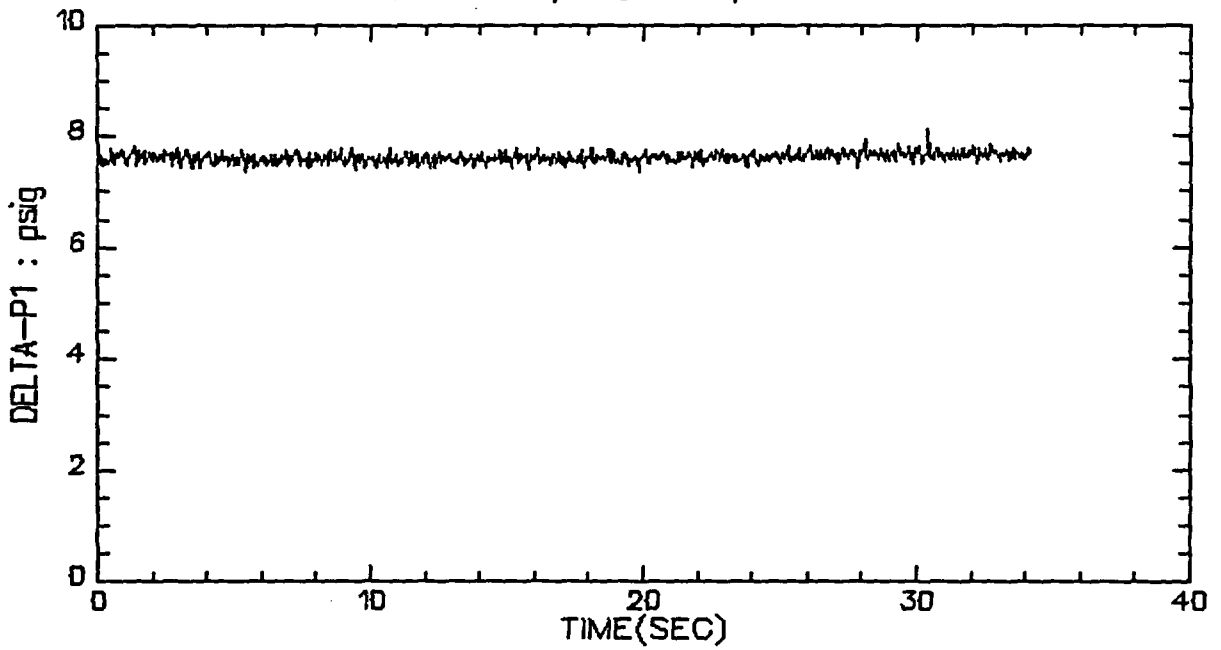

VALVE B, TEST 5, STEP 1

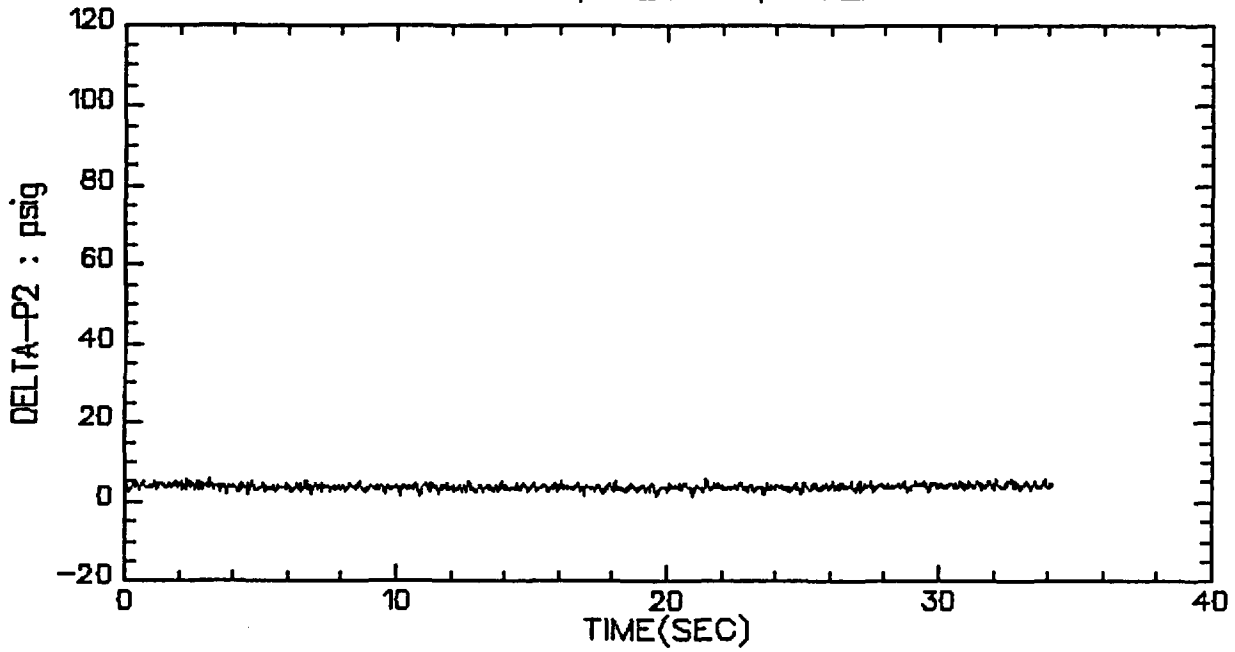

VALVE B, TEST 5, STEP 1

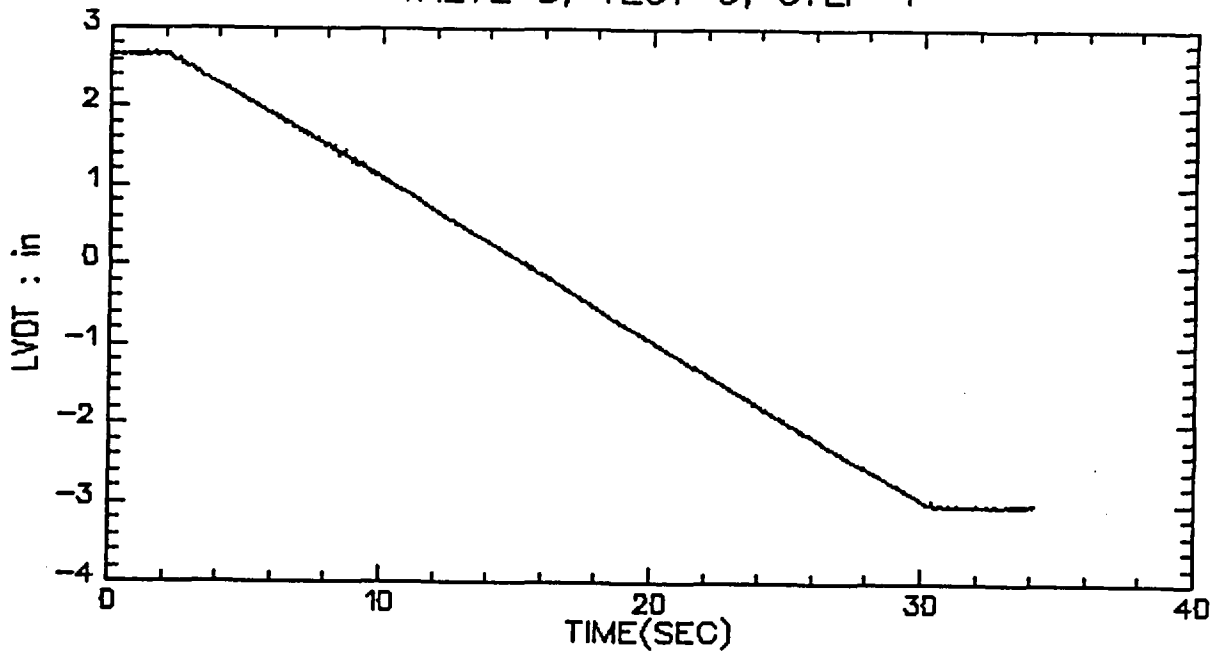

VALVE B, TEST 5, STEP 1

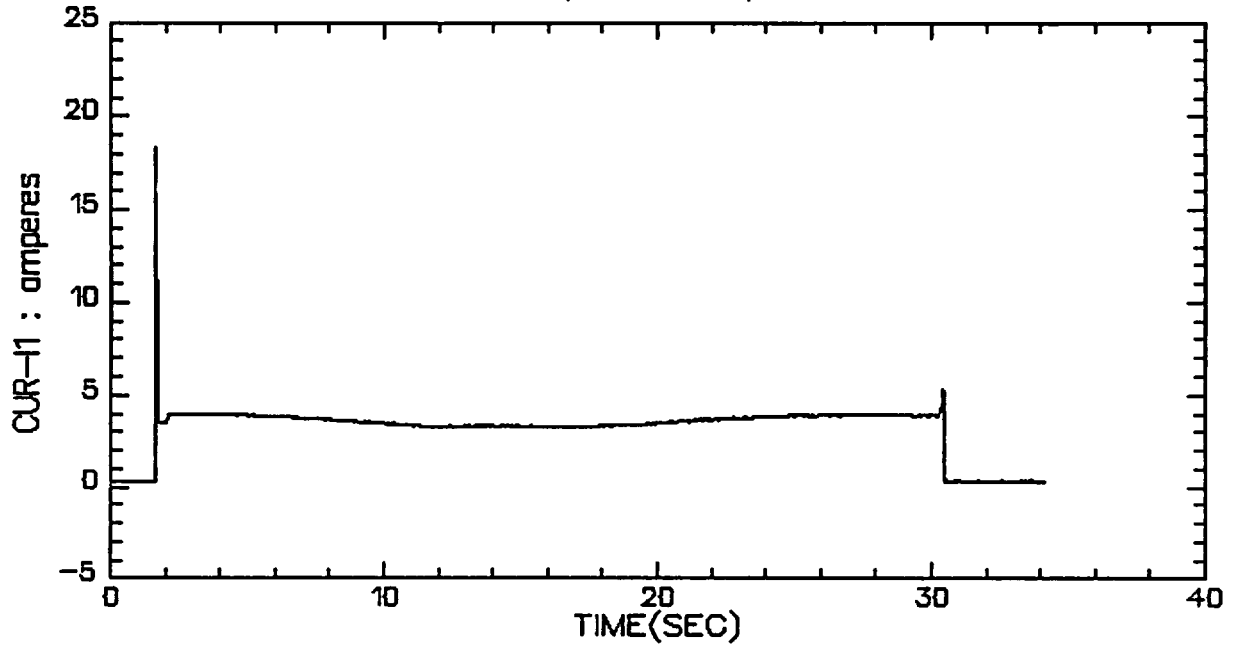

VALVE B, TEST 5, STEP 1

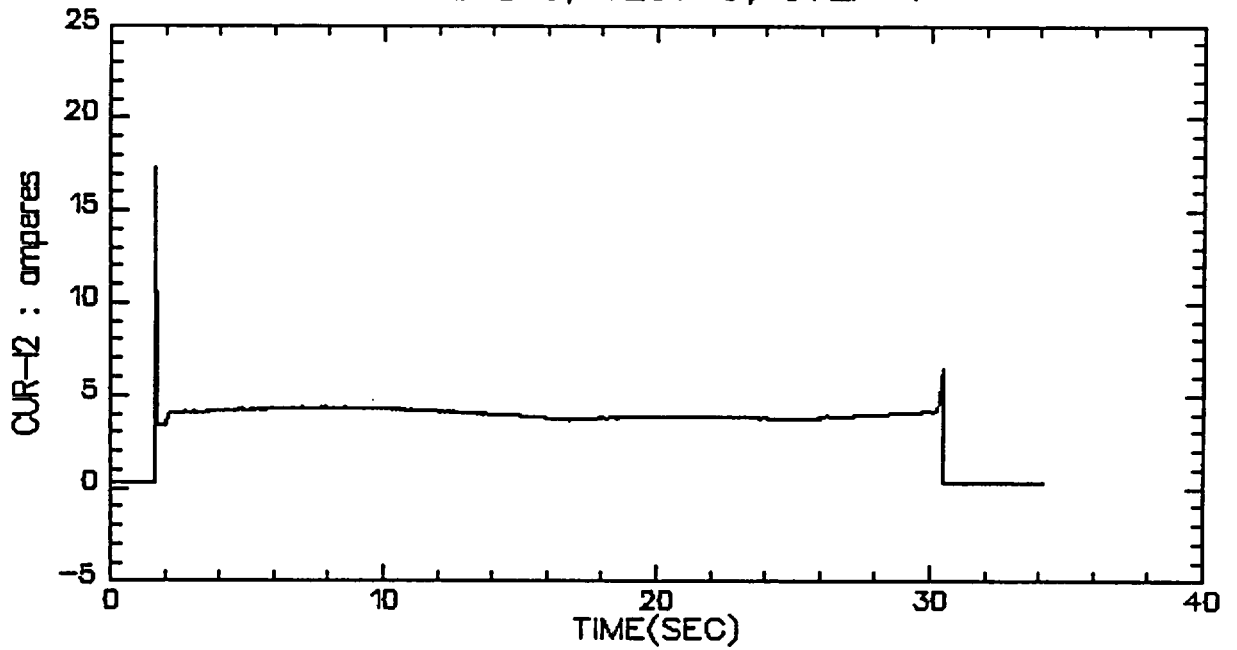

VALVE B, TEST 5, STEP 1

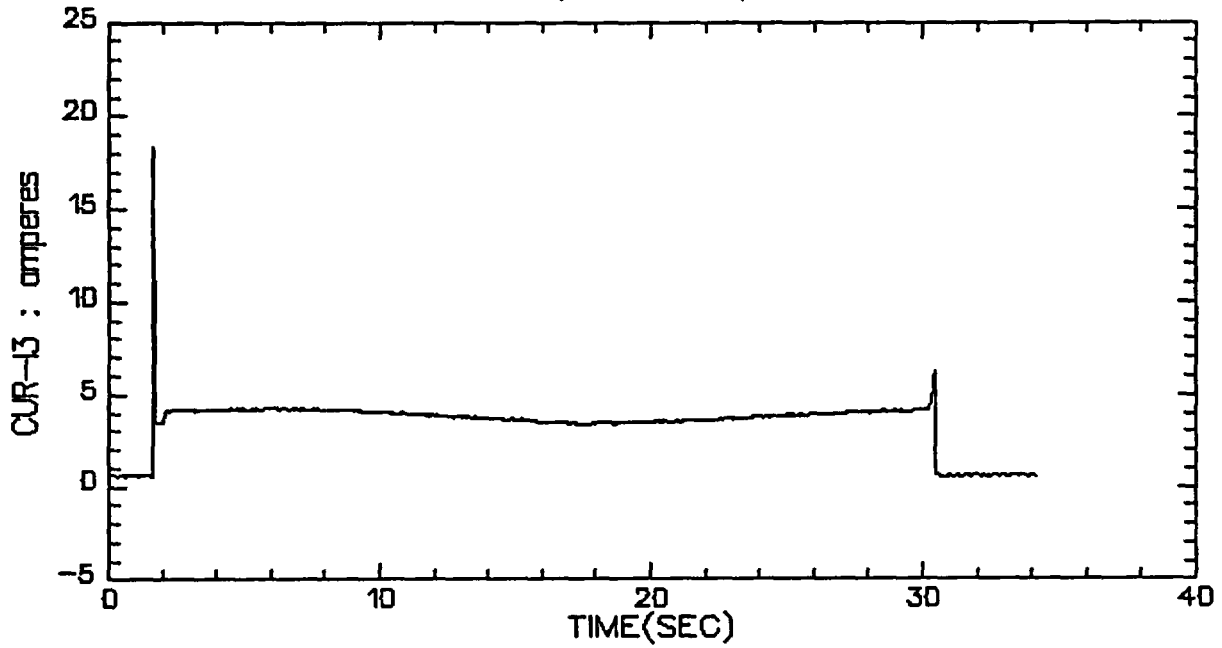

VALVE B, TEST 5, STEP 1

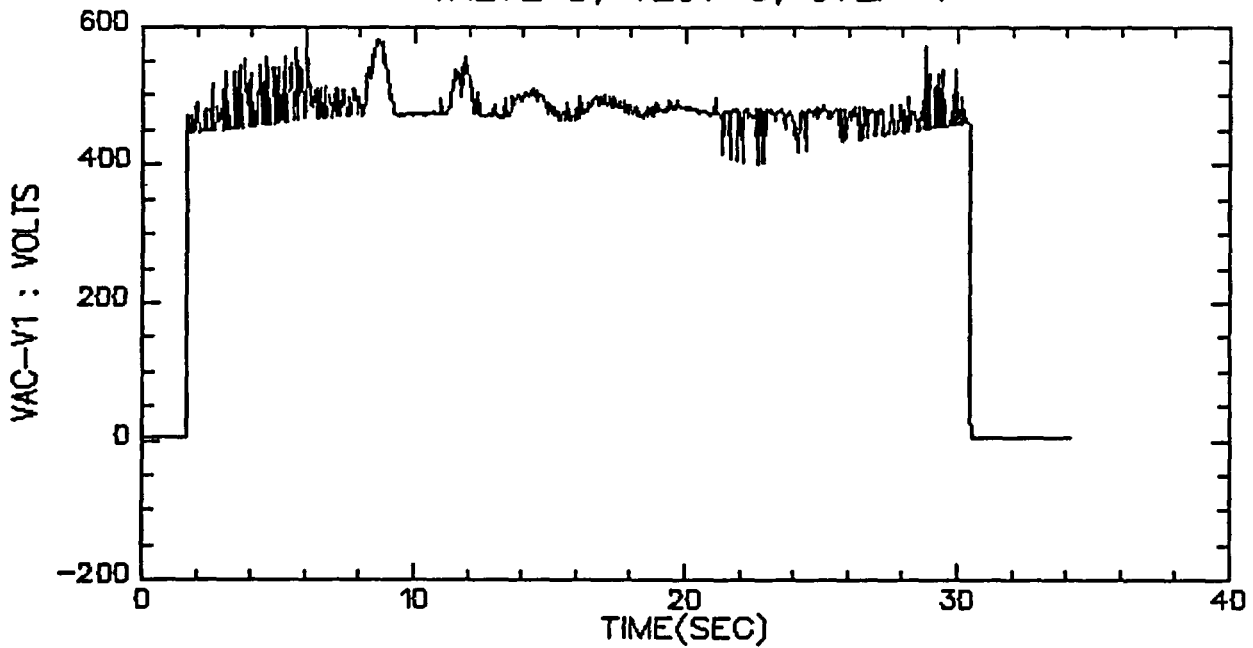

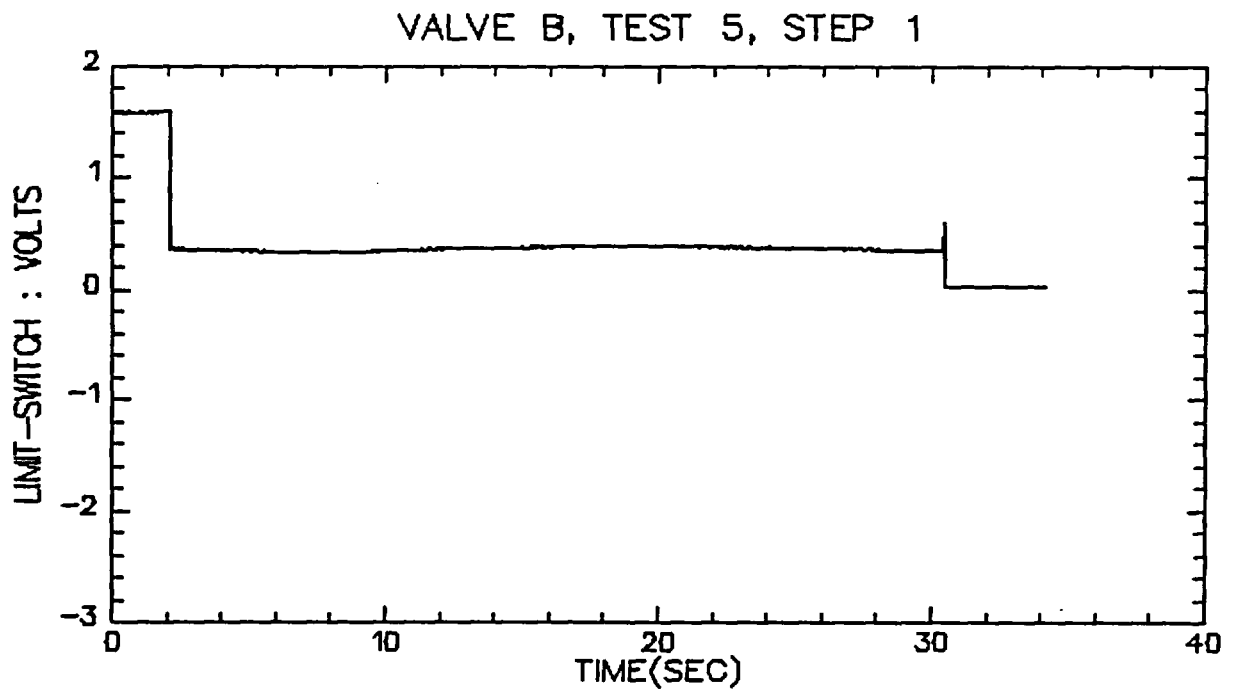
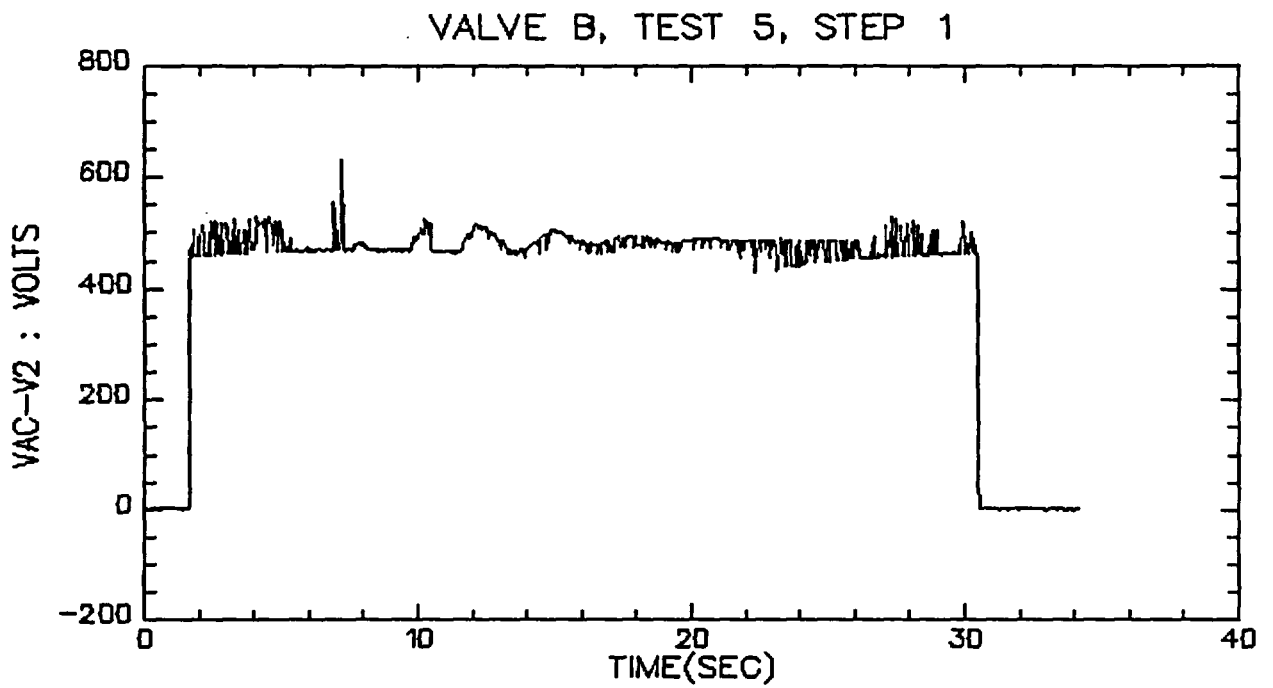

VALVE B, TEST 5, STEP 1

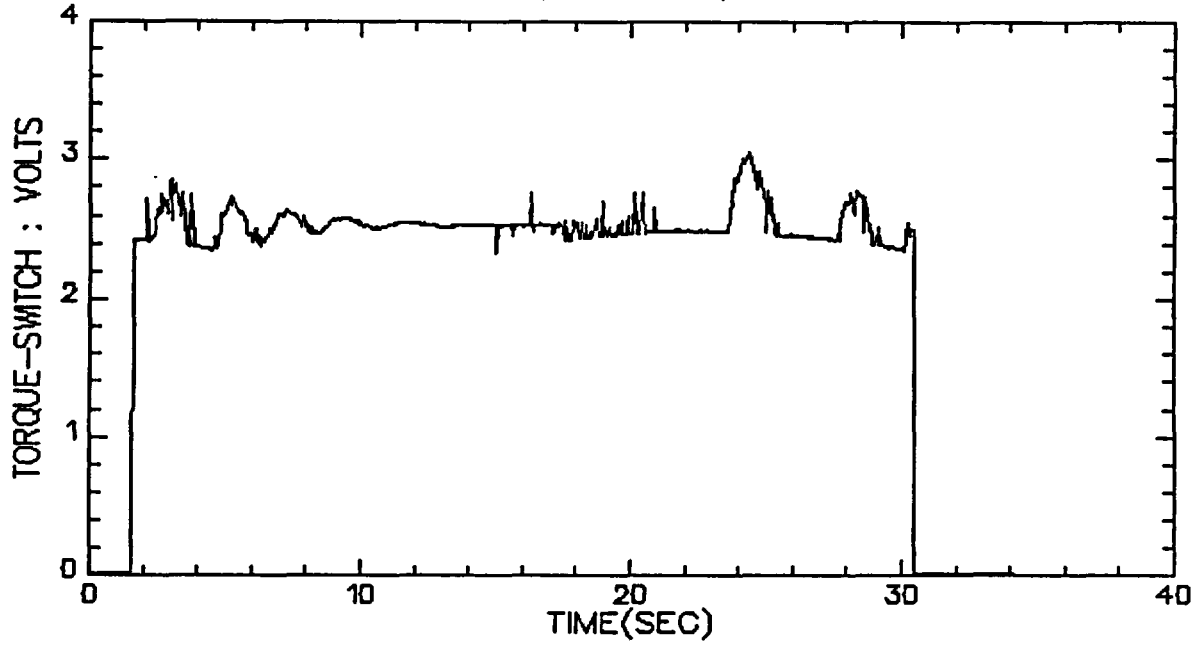

VALVE B, TEST 5, STEP 1

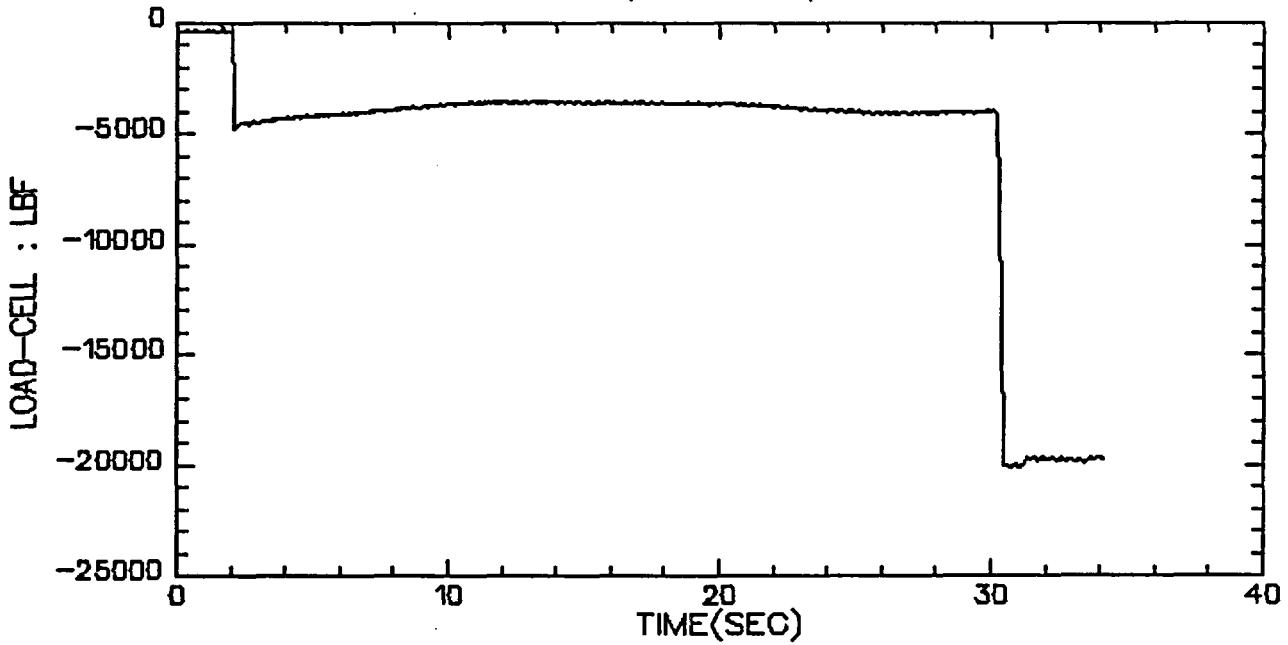

VALVE B, TEST 5, STEP 2

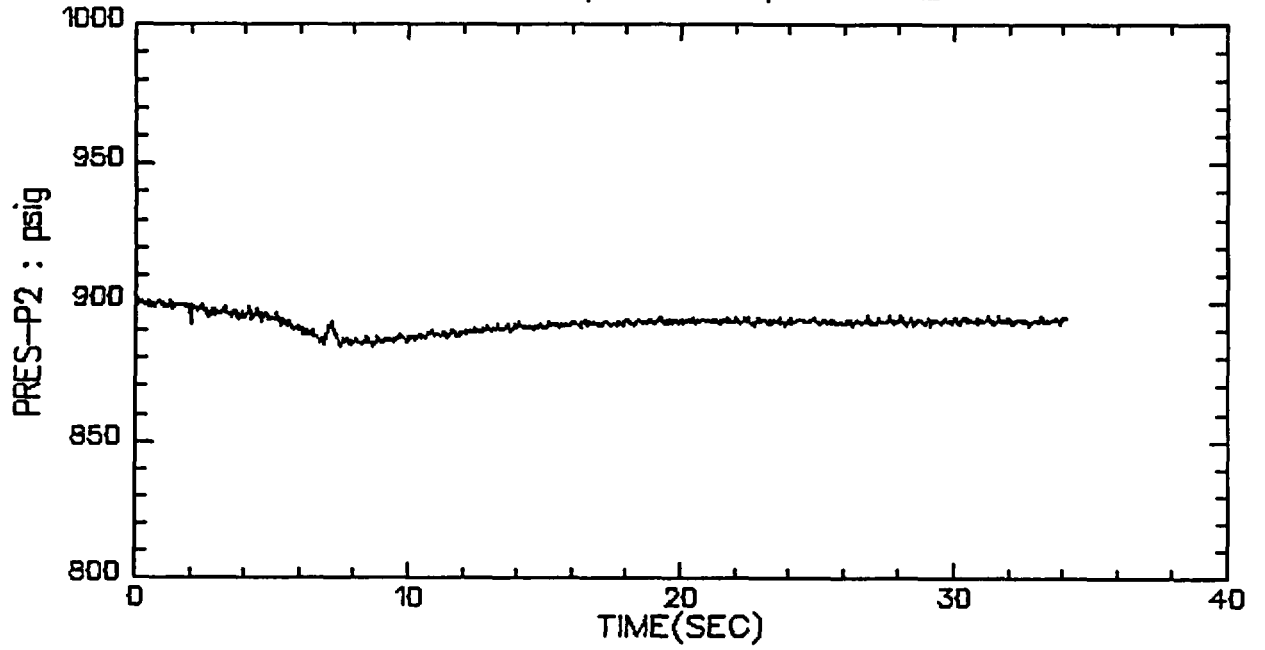

VALVE B, TEST 5, STEP 2

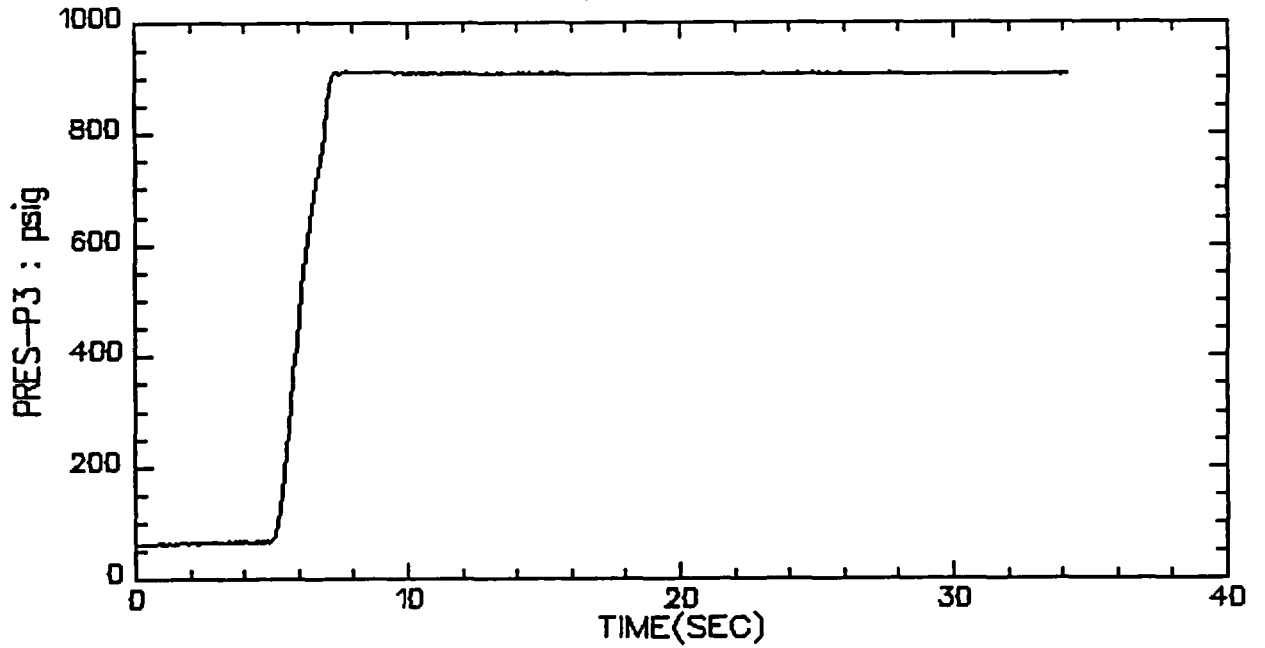

VALVE B, TEST 5, STEP 2

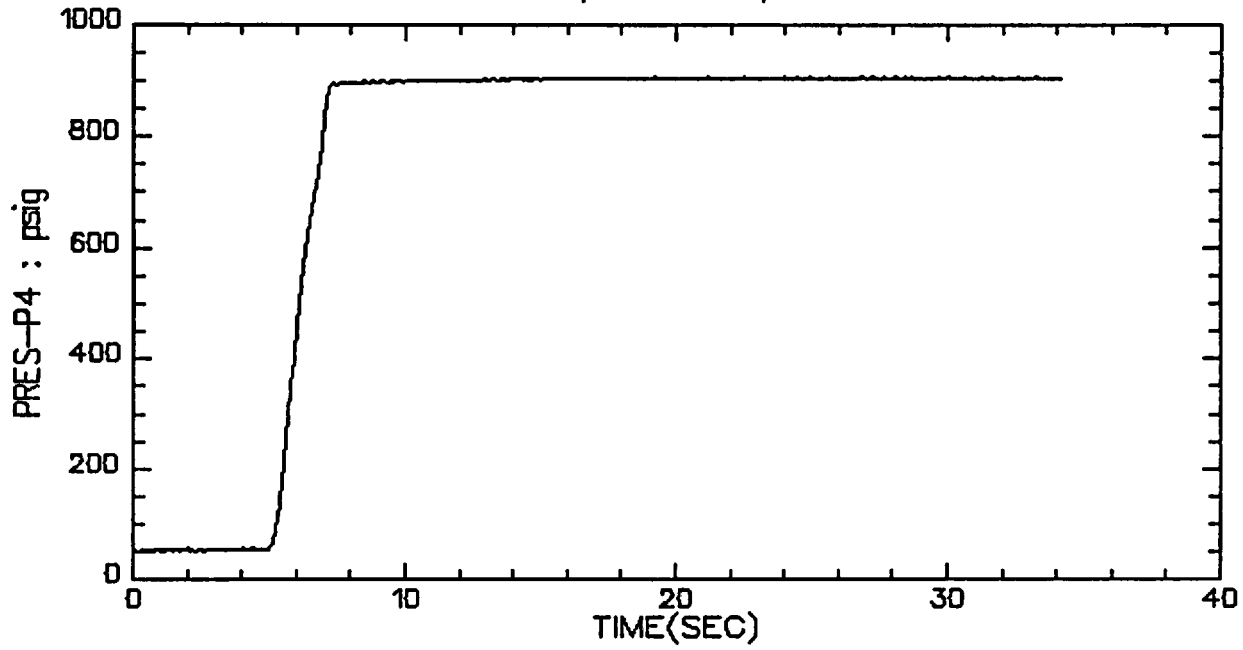

VALVE B, TEST 5, STEP 2

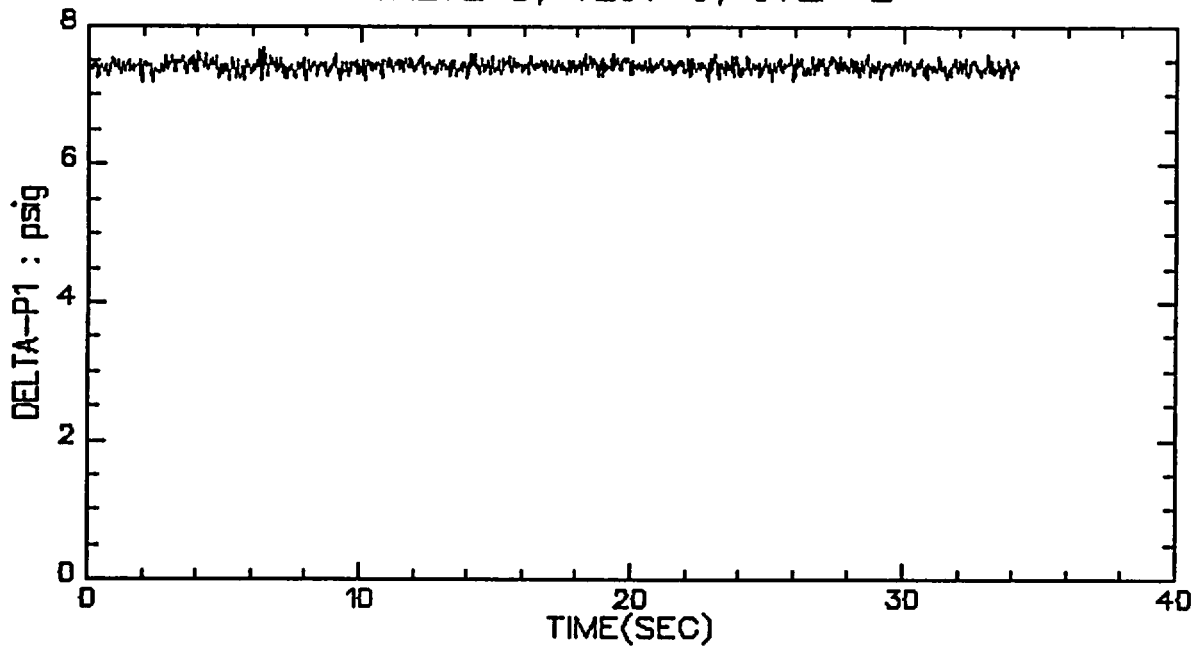

VALVE B, TEST 5, STEP 2

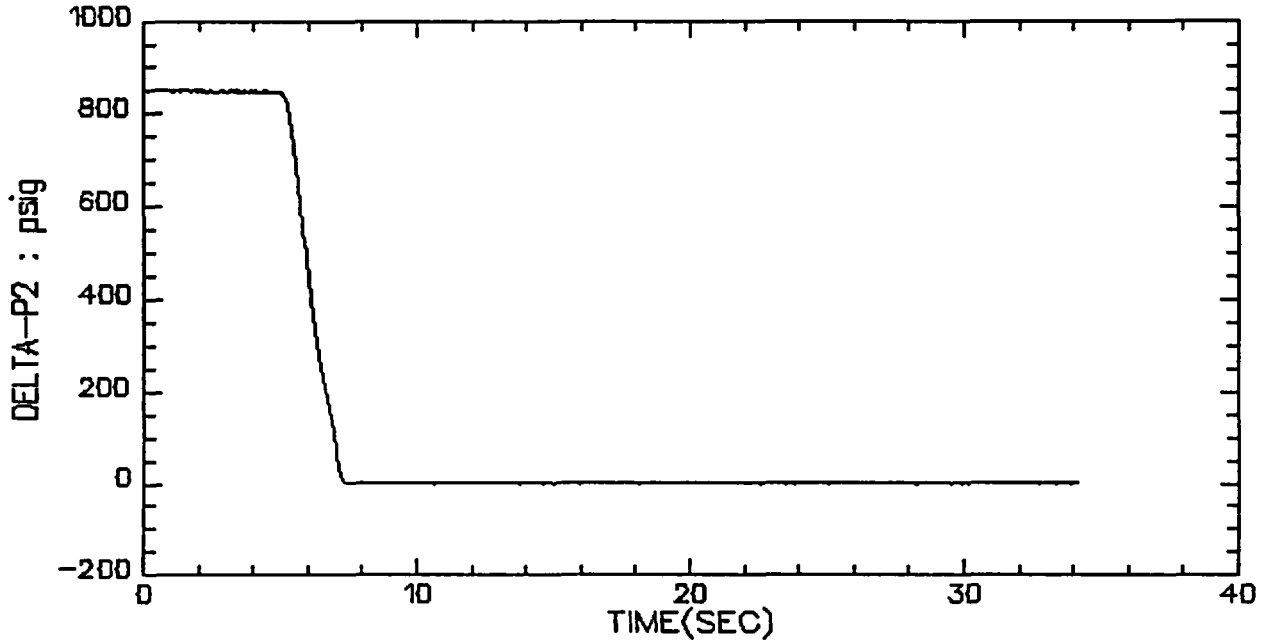

VALVE B, TEST 5, STEP 2

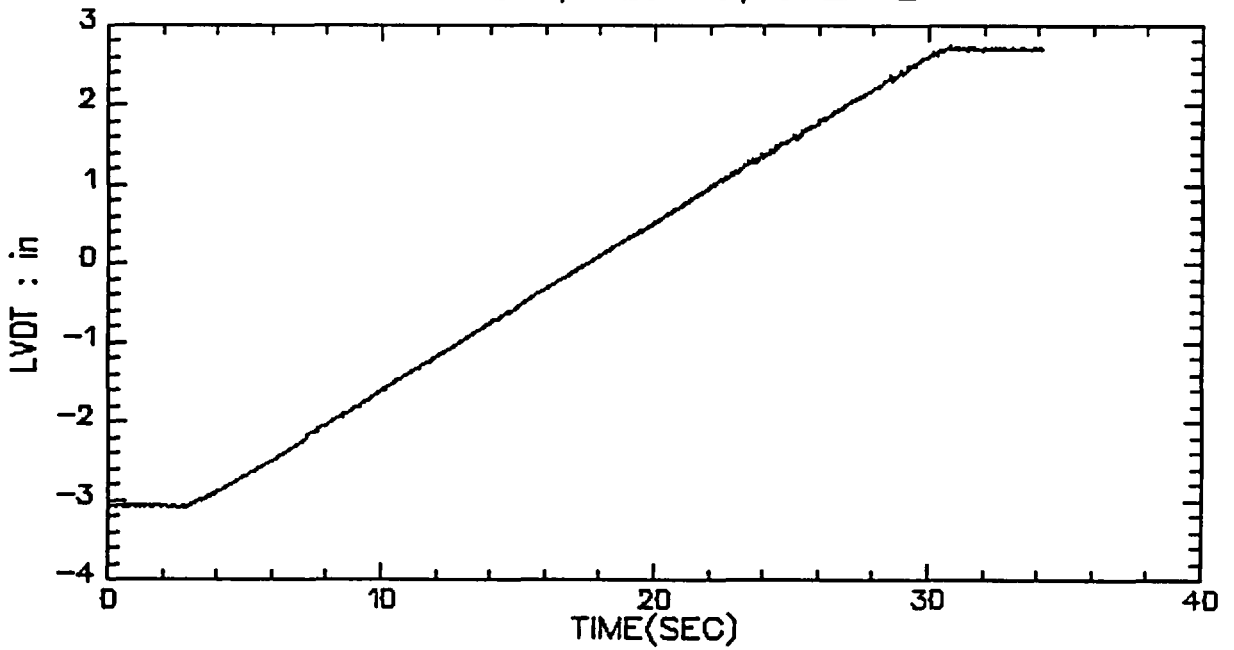

VALVE B, TEST 5, STEP 2

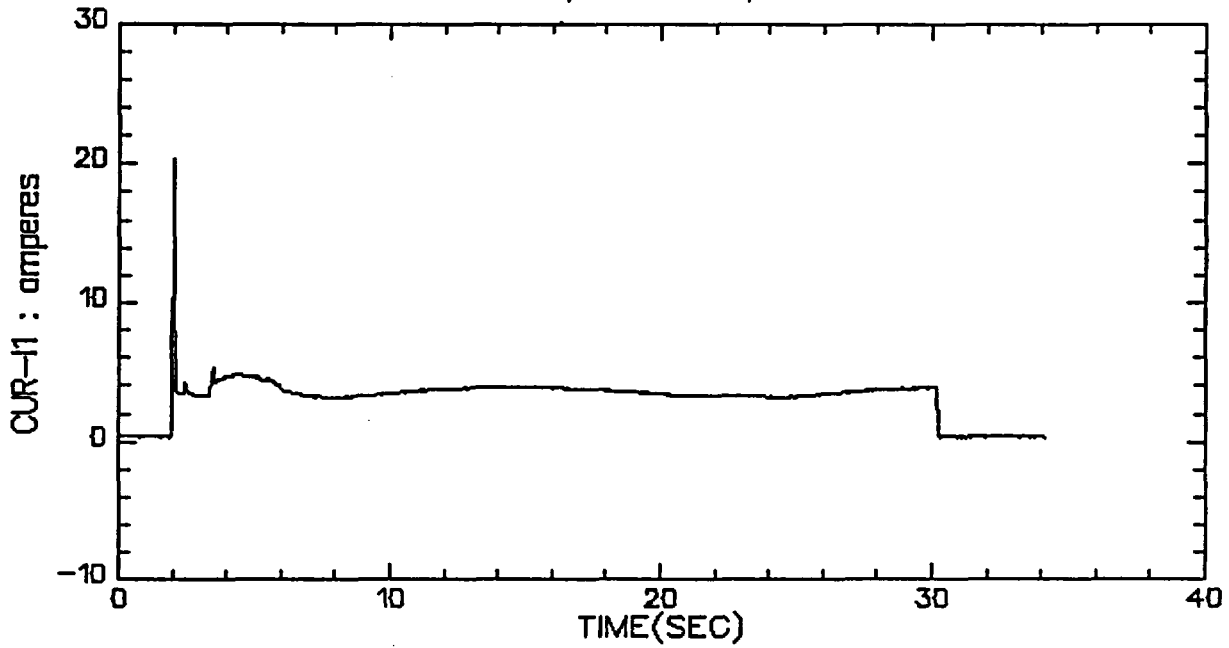

VALVE B, TEST 5, STEP 2

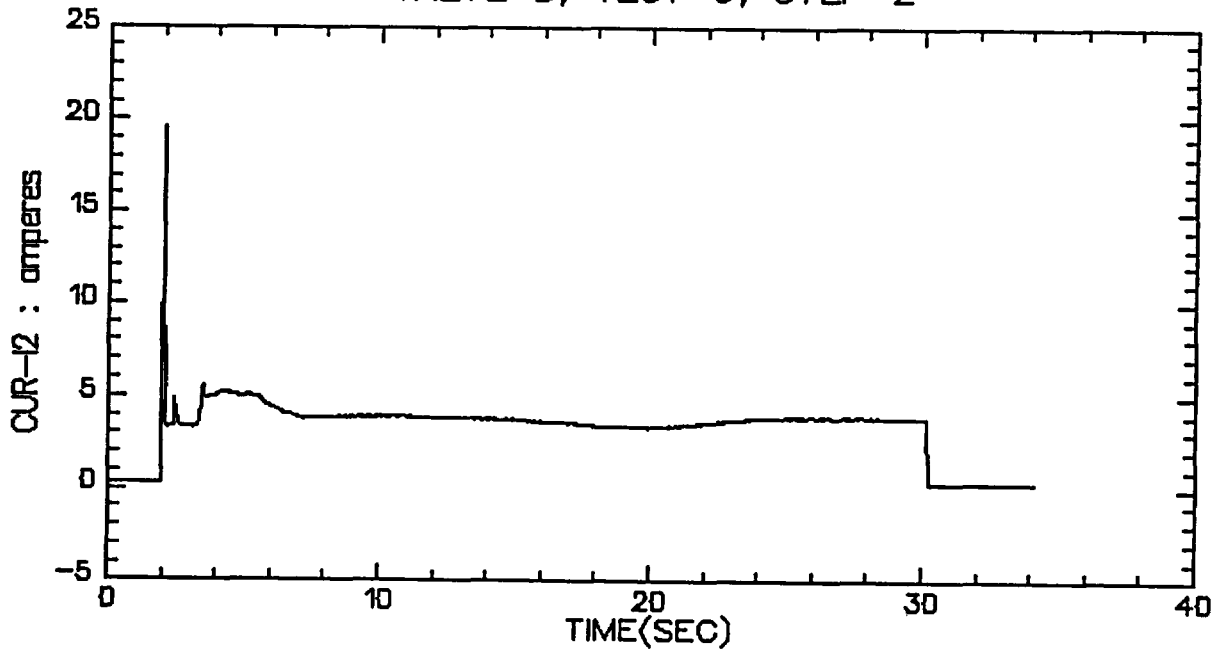

VALVE B, TEST 5, STEP 2

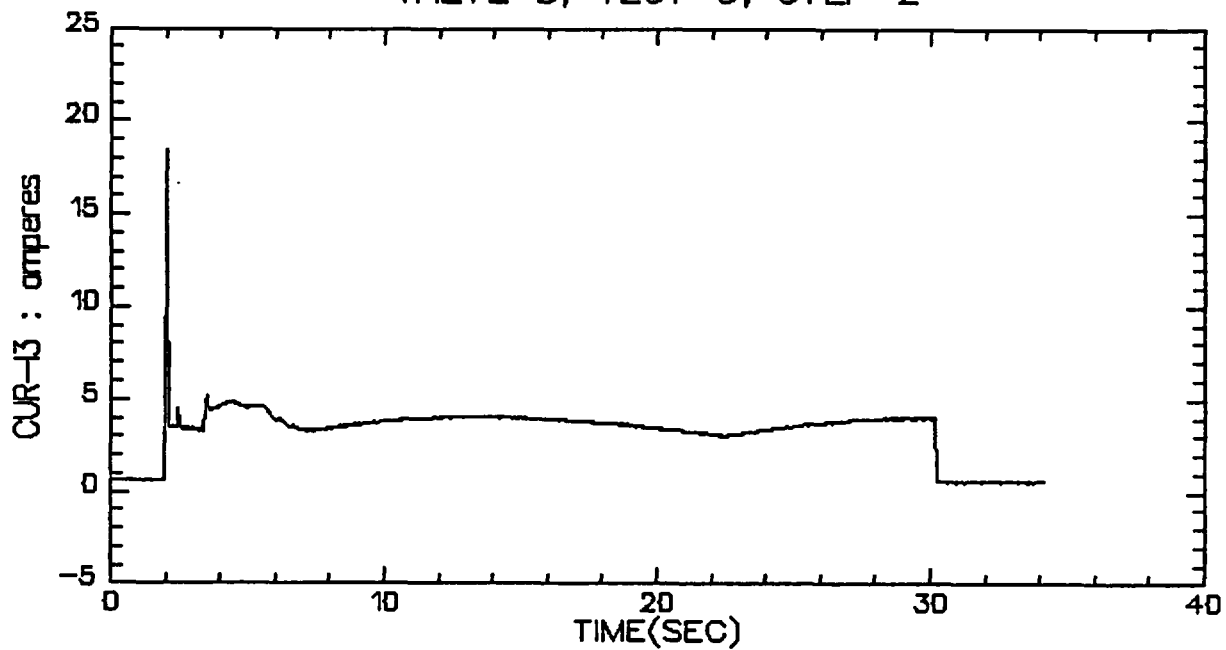

VALVE B, TEST 5, STEP 2

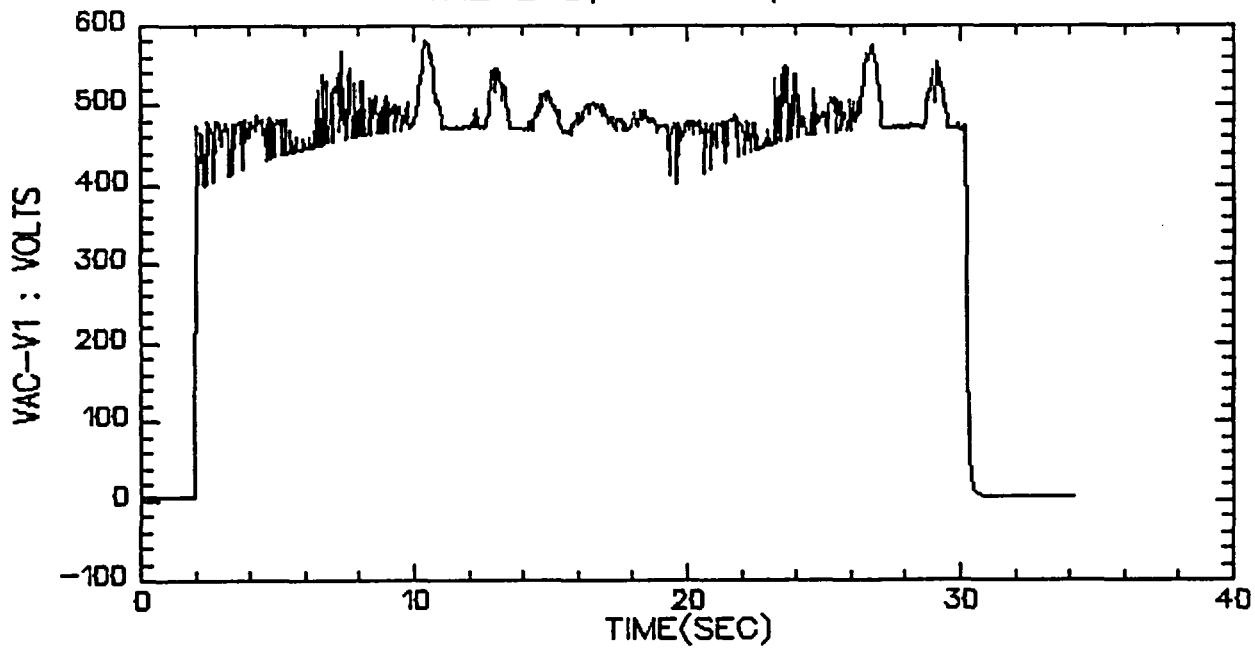

VALVE B, TEST 5, STEP 2

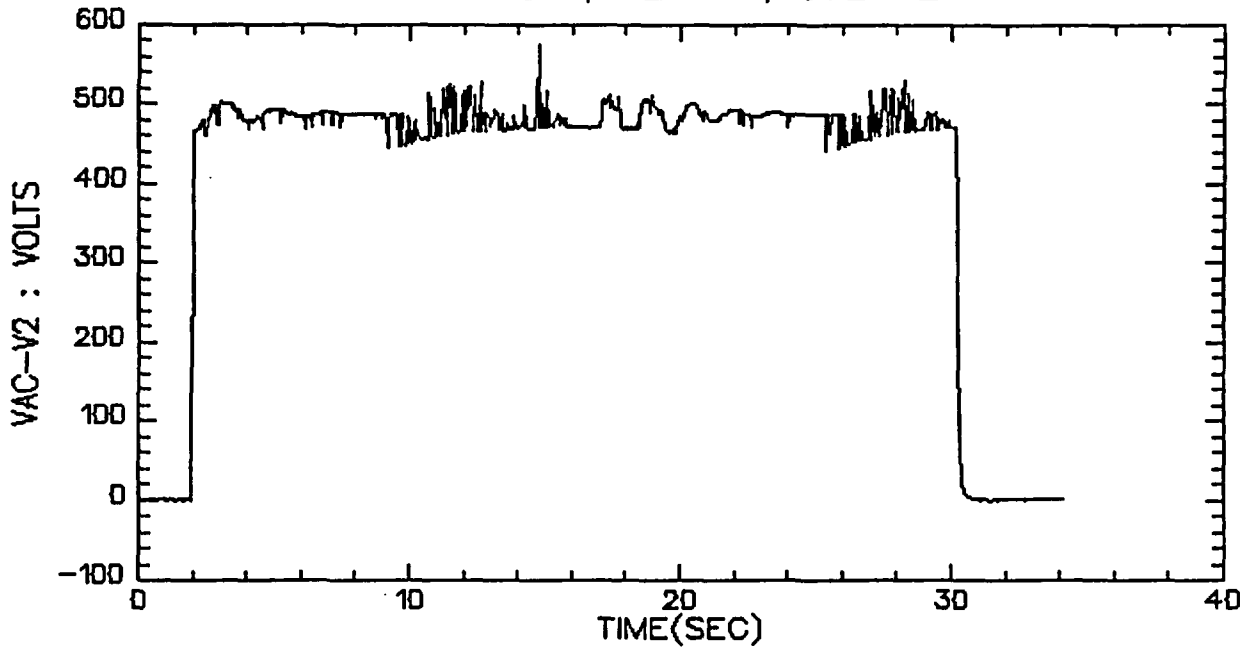

VALVE B, TEST 5, STEP 2

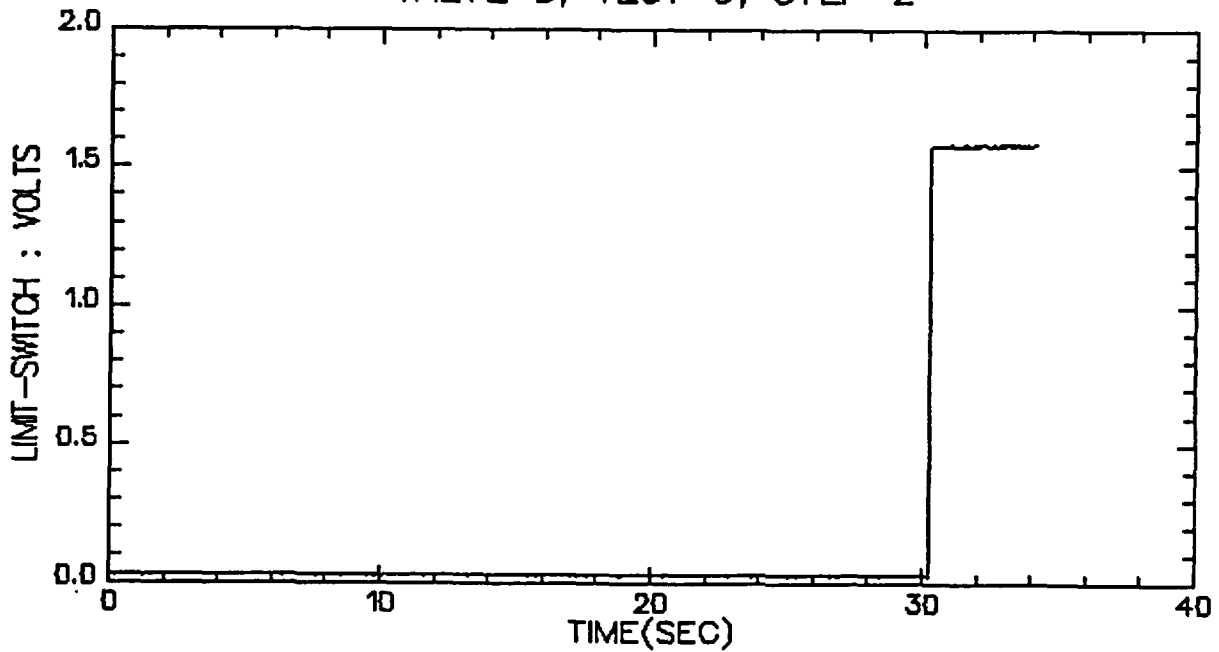

VALVE B, TEST 5, STEP 2

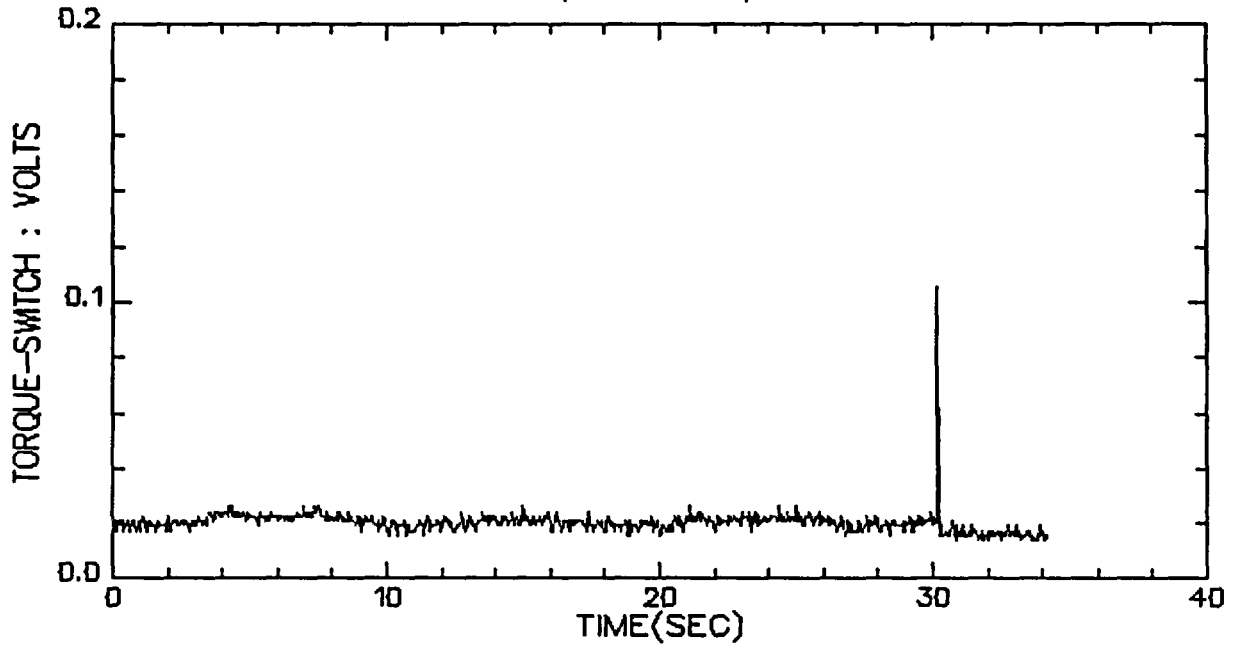

VALVE B, TEST 5, STEP 2

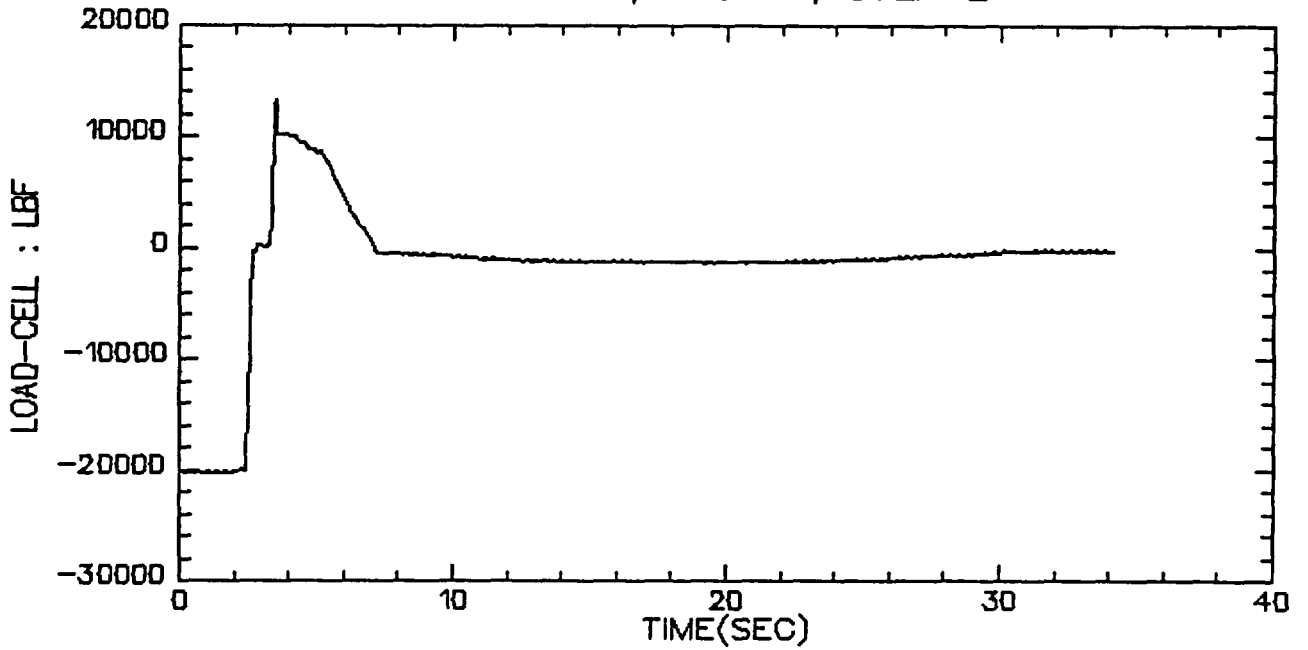

VALVE B, TEST 5, STEP 3&4

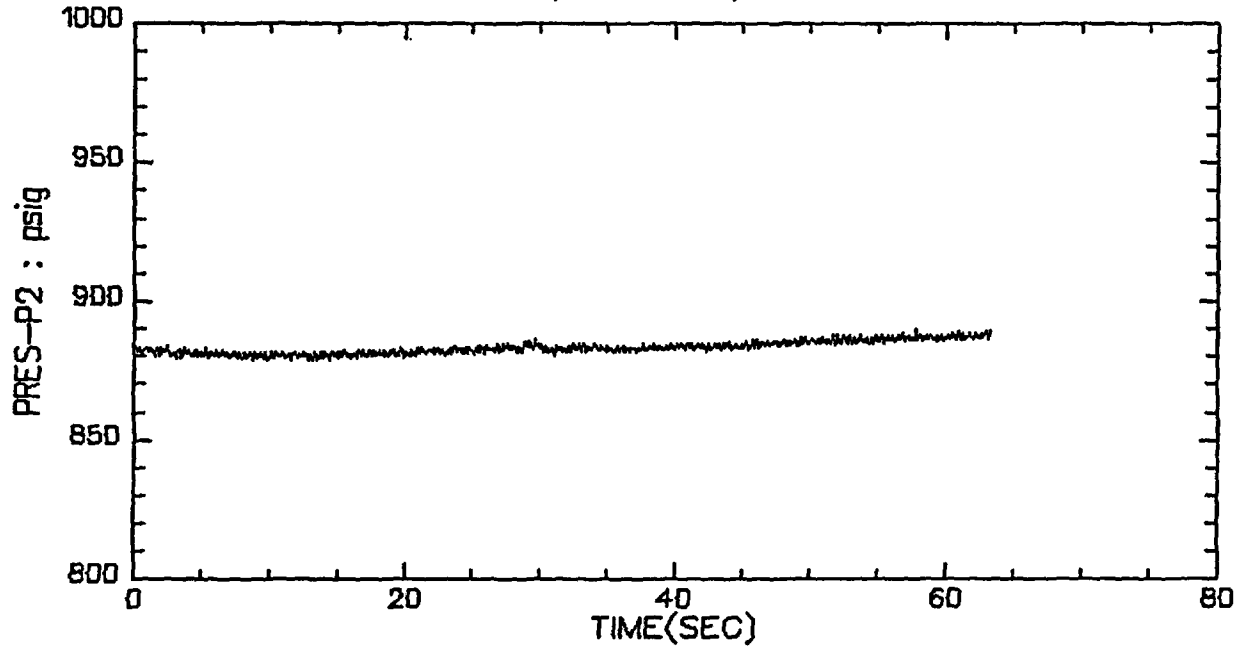

VALVE B, TEST 5, STEP 3&4

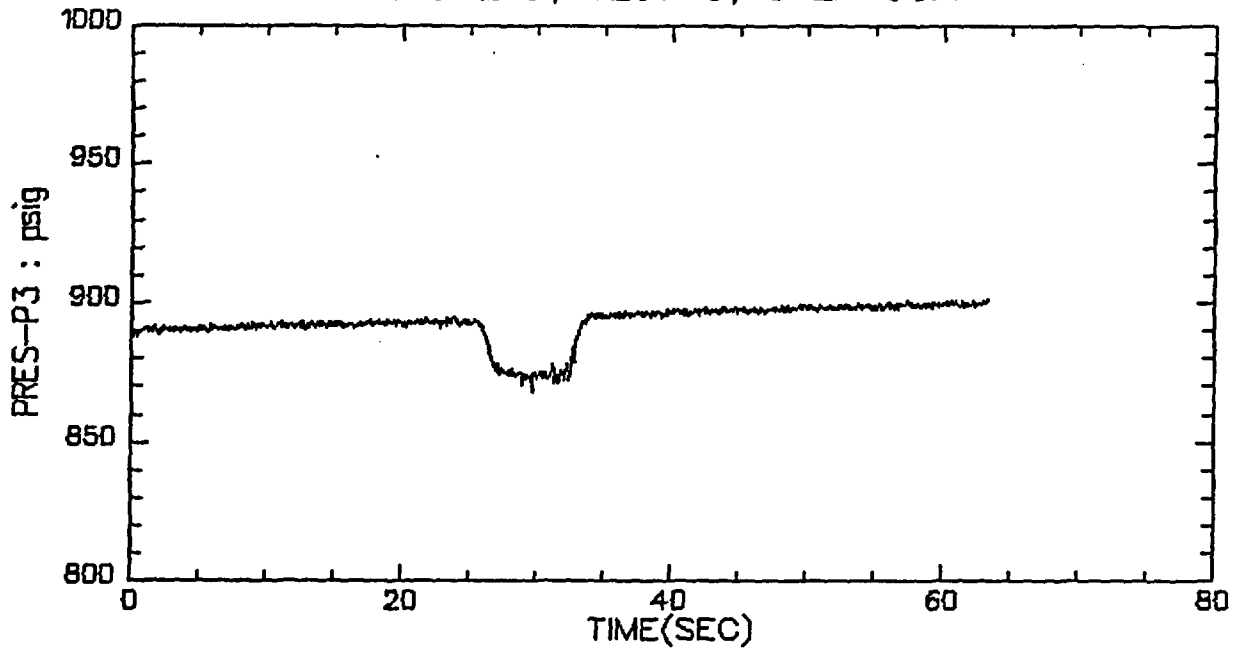

VALVE B, TEST 5, STEP 3&4

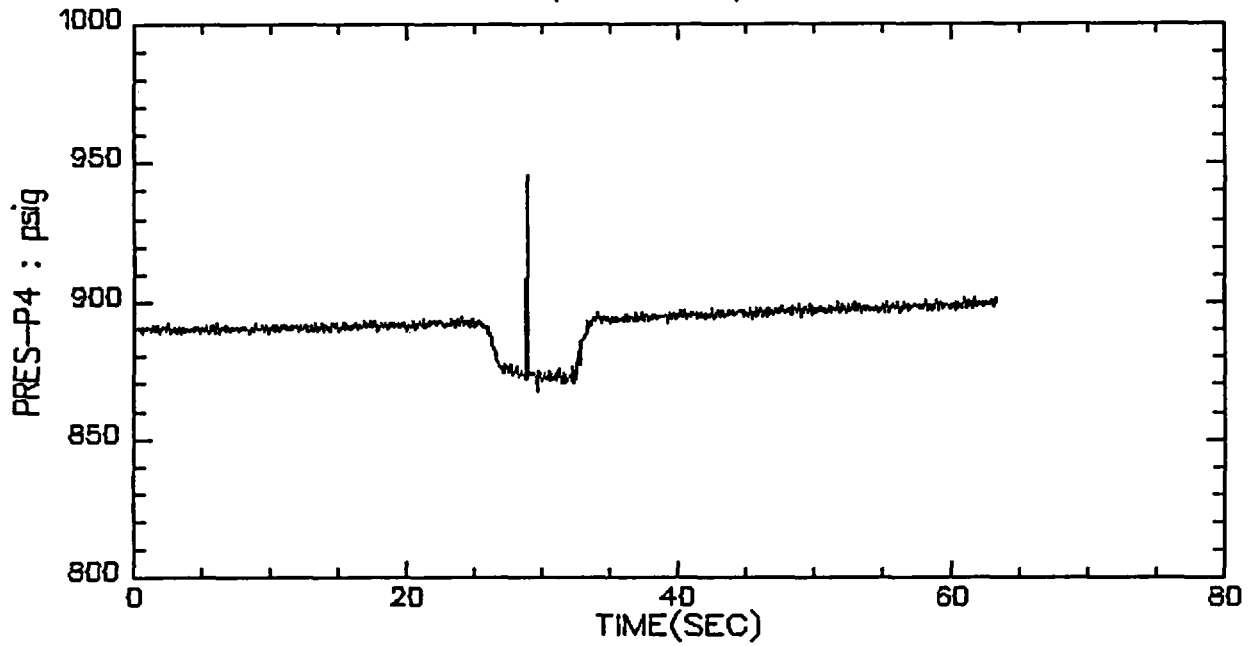

VALVE B, TEST 5, STEP 3&4

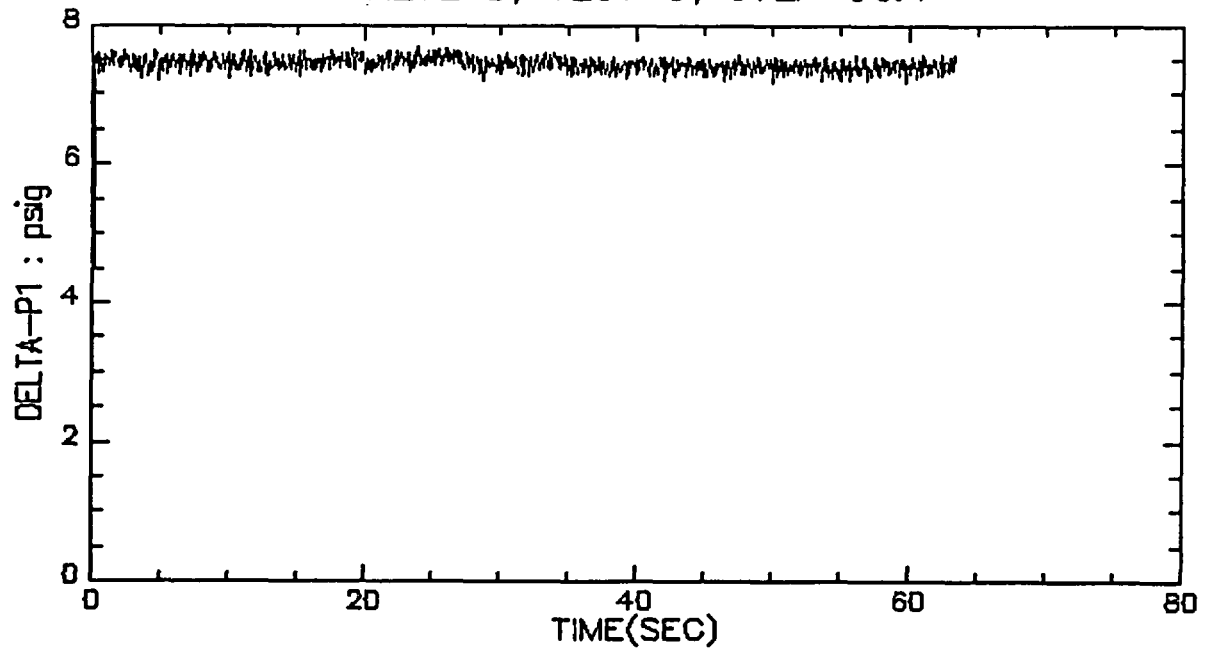

VALVE B, TEST 5, STEP 3&4

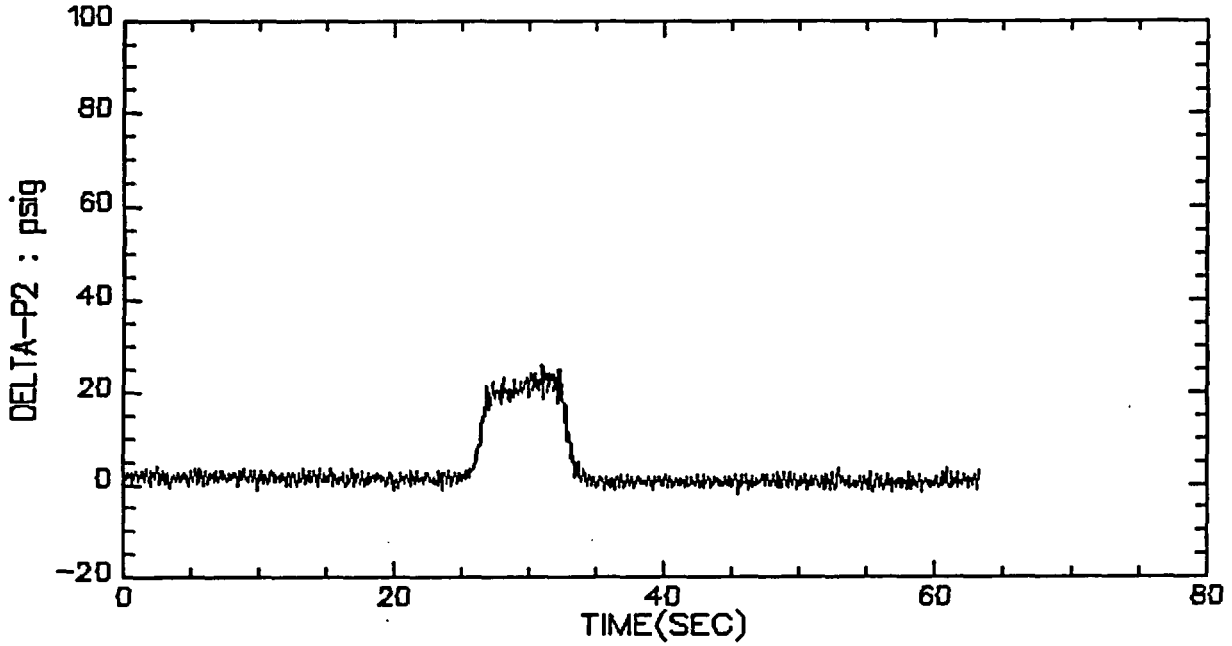

VALVE B, TEST 5, STEP 3&4

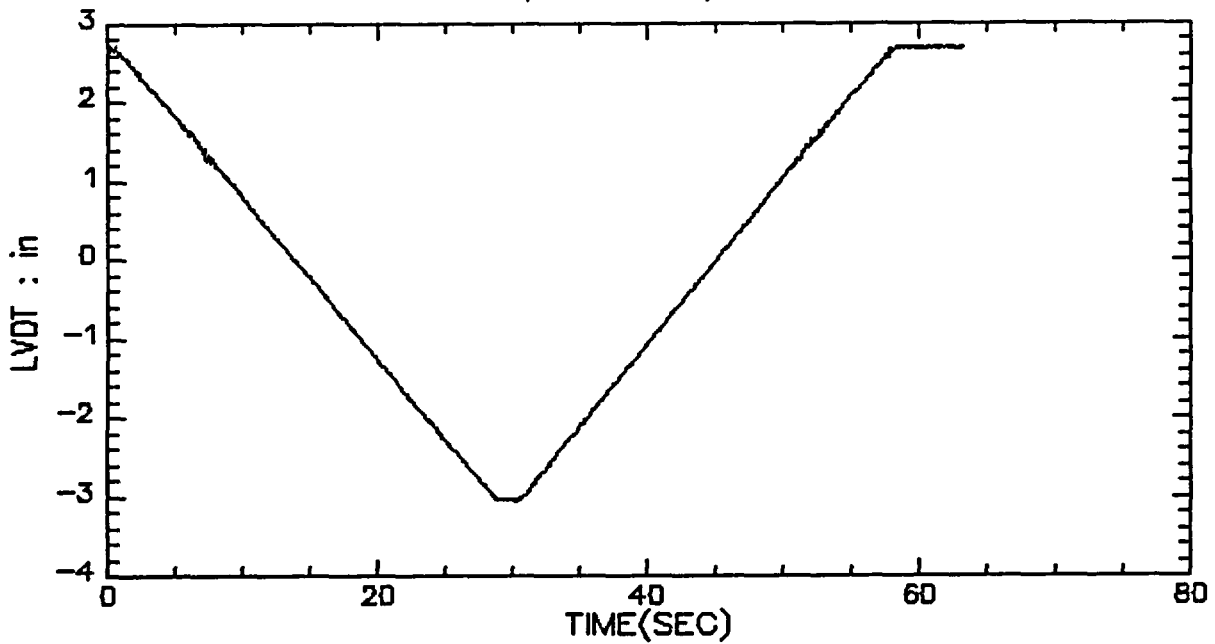

VALVE B, TEST 5, STEP 3&4

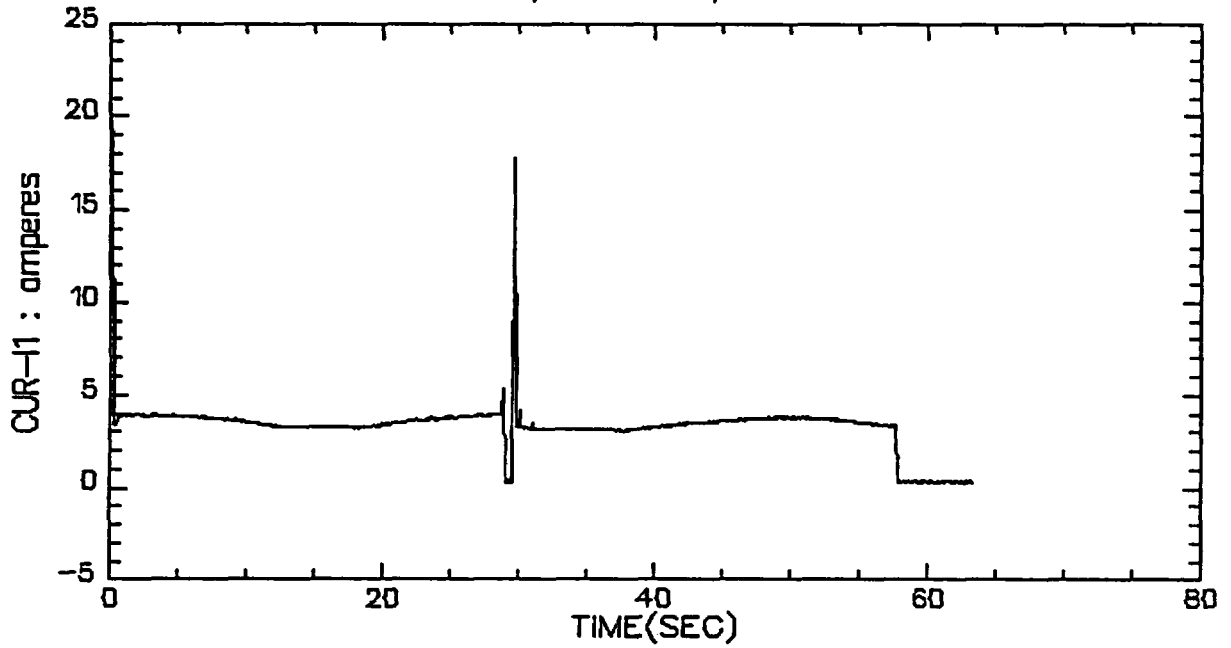

VALVE B, TEST 5, STEP 3&4

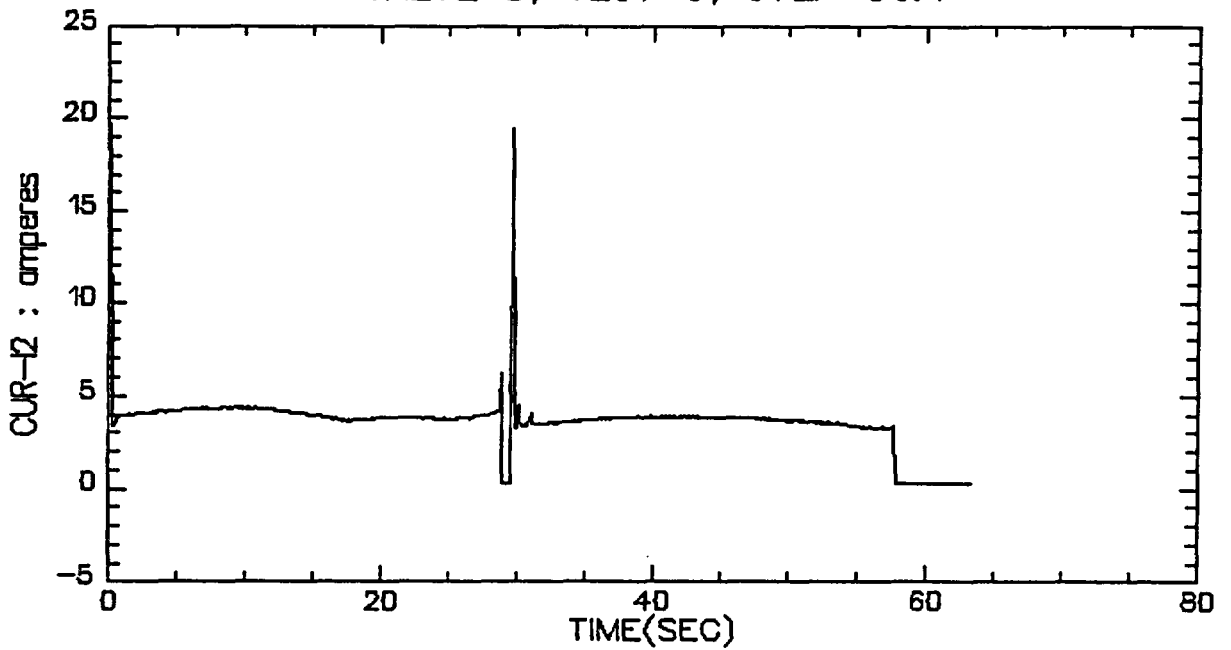

VALVE B, TEST 5, STEP 3&4

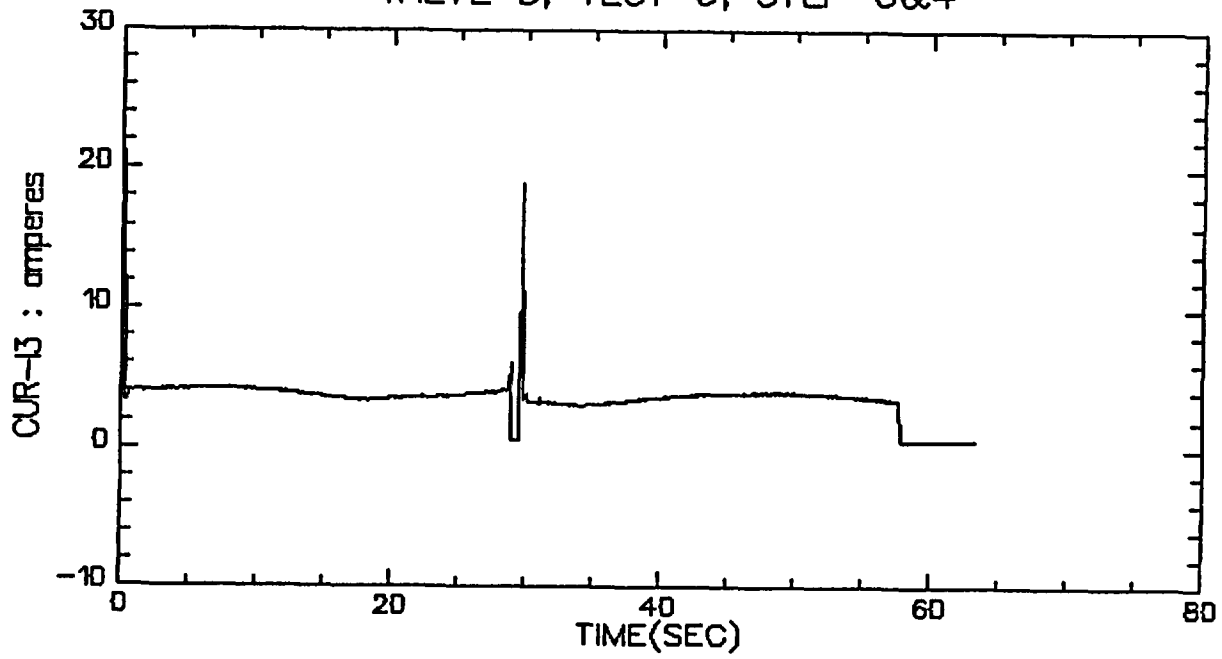

VALVE B, TEST 5, STEP 3&4

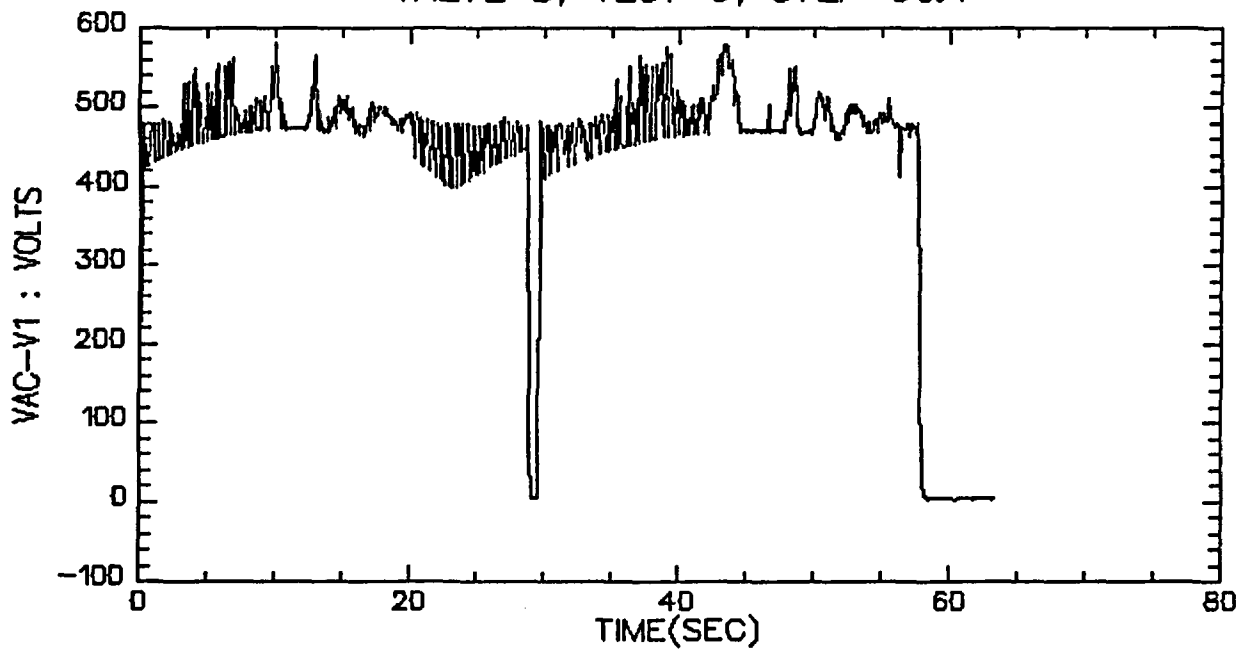

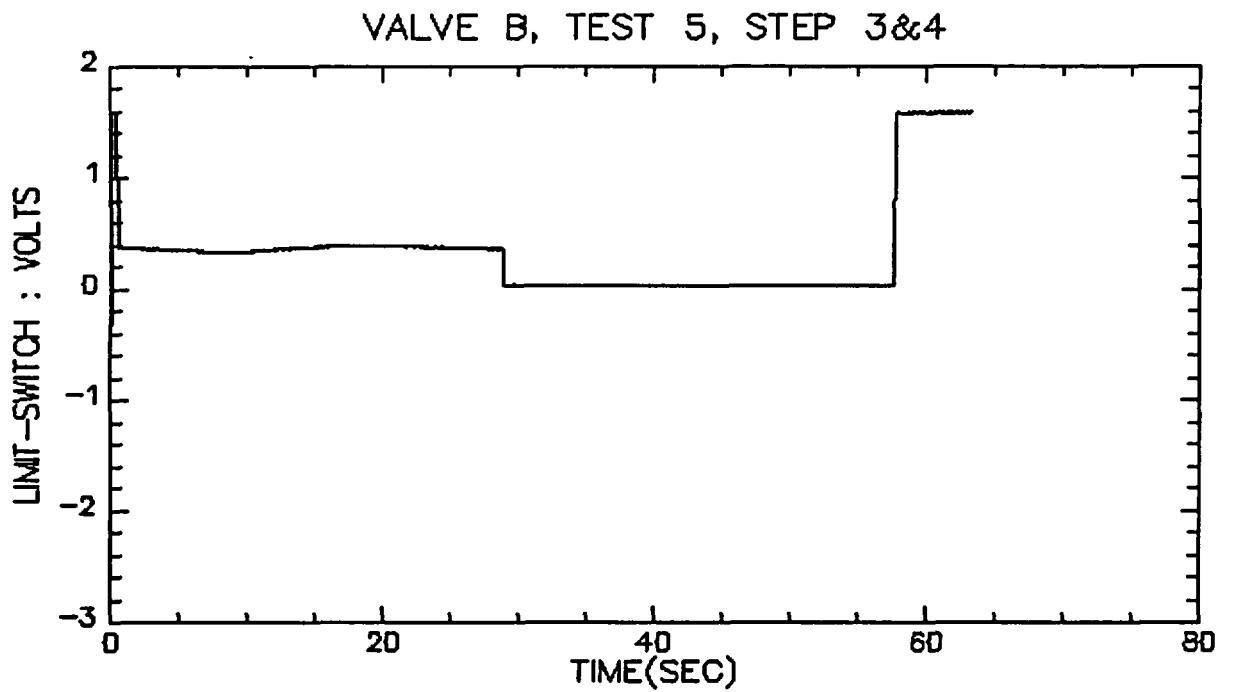
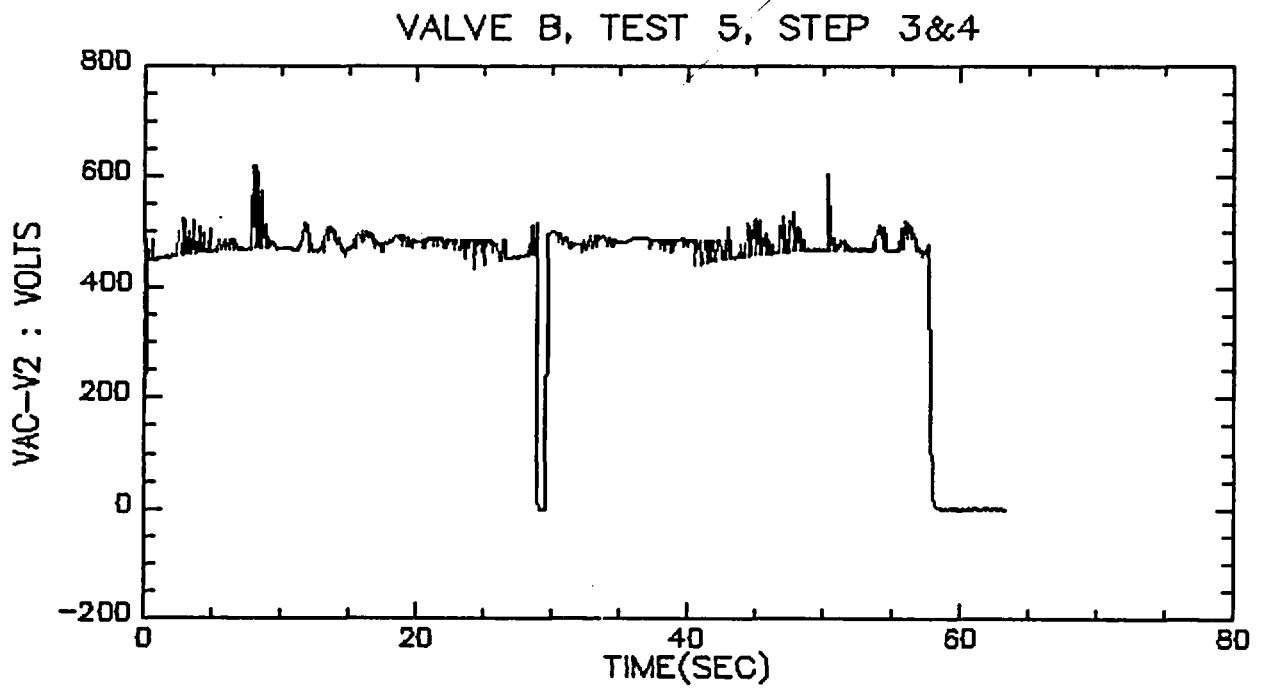

VALVE B, TEST 5, STEP 3&4

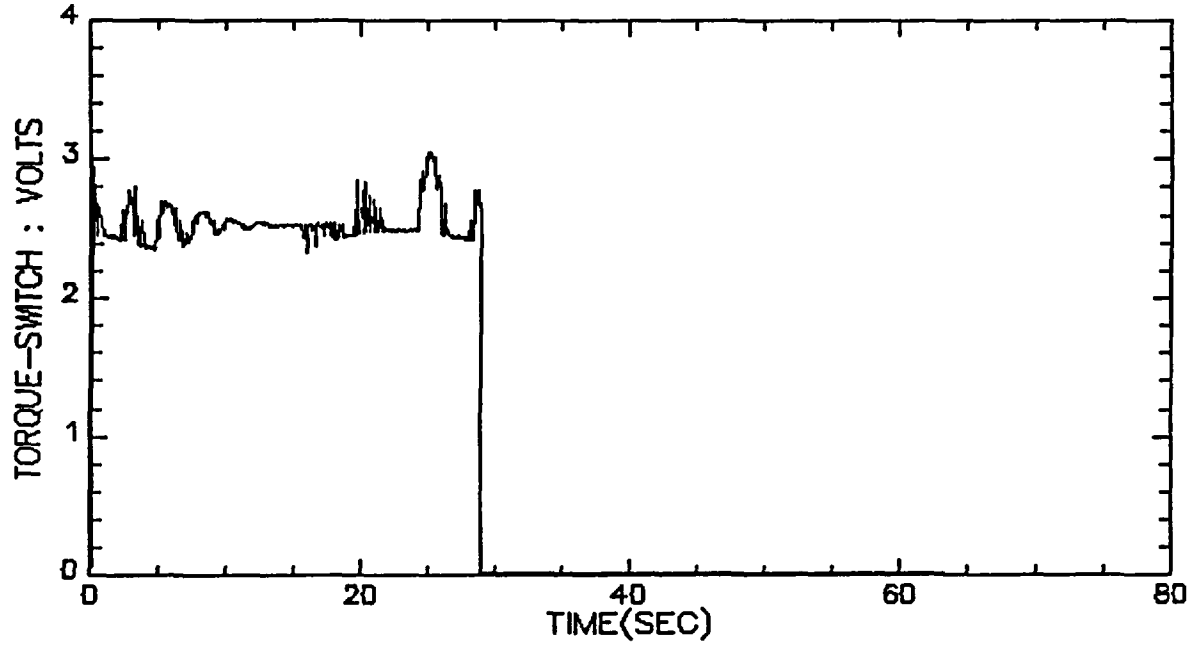

VALVE B, TEST 5, STEP 3&4

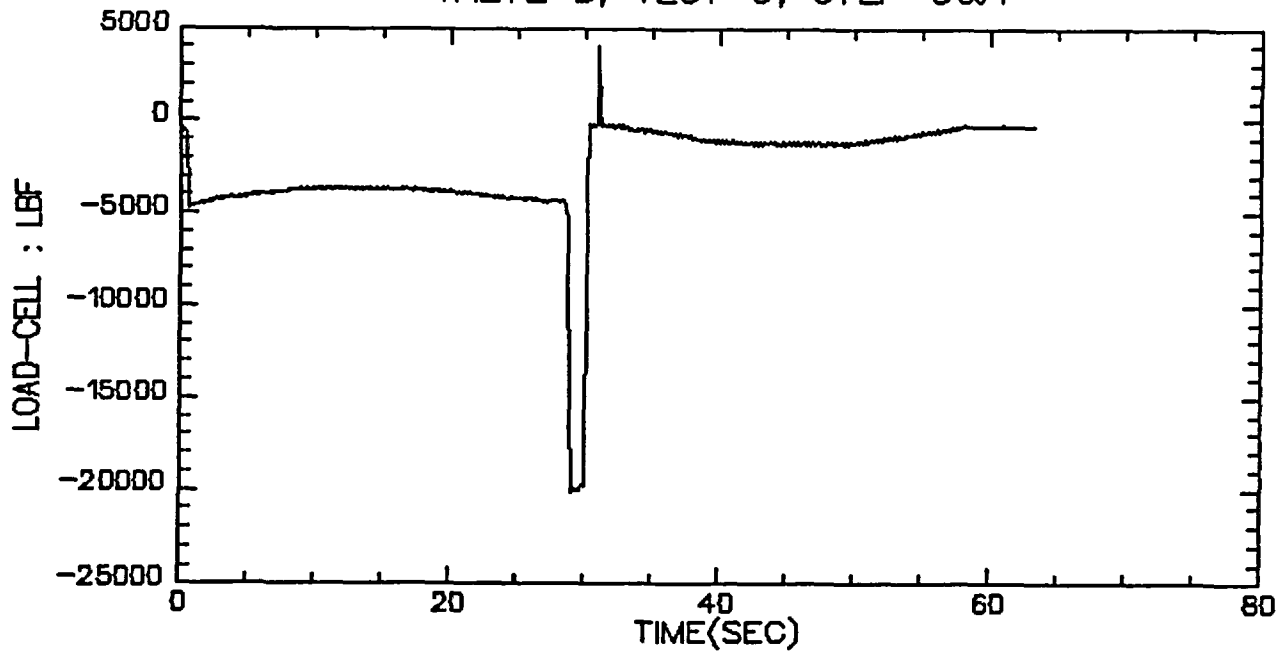

VALVE B, TEST 5, STEP 5

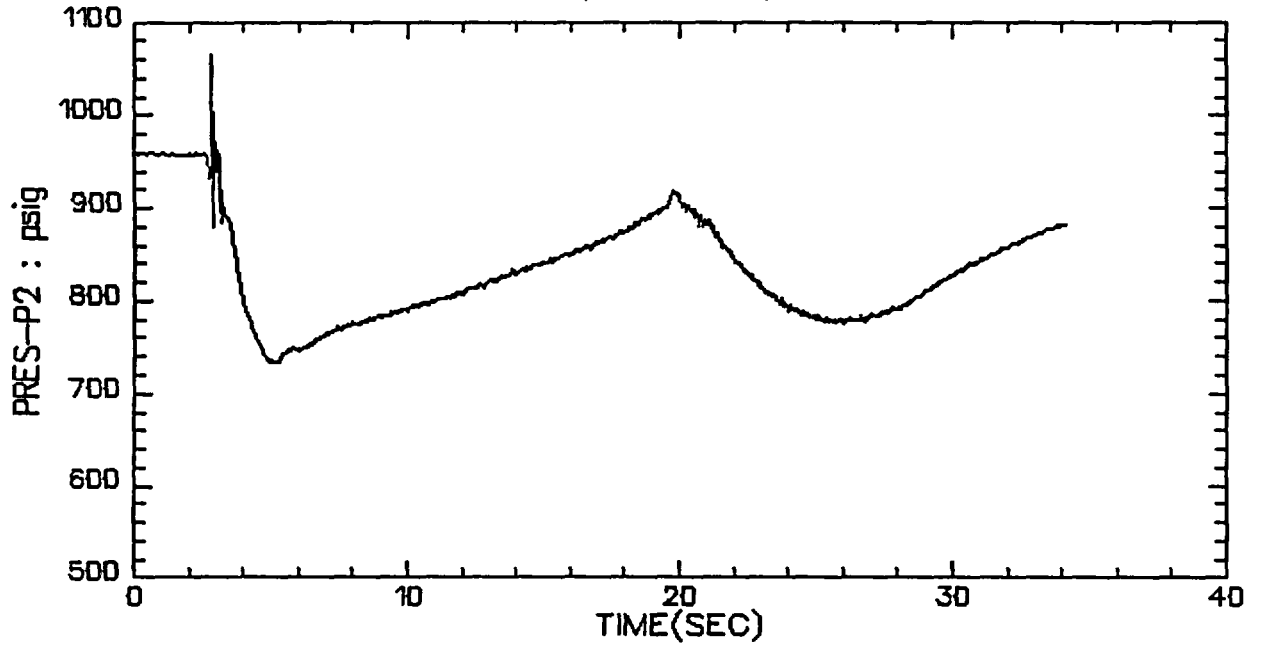

VALVE B, TEST 5, STEP 5

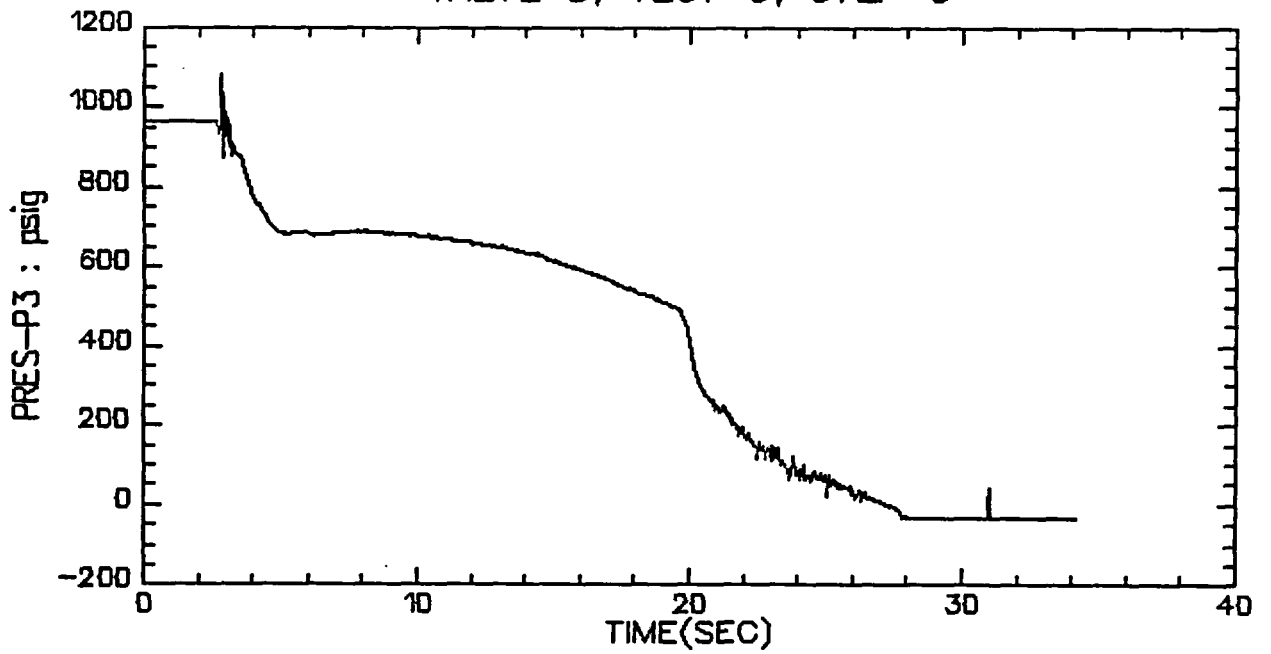

VALVE B, TEST 5, STEP 5

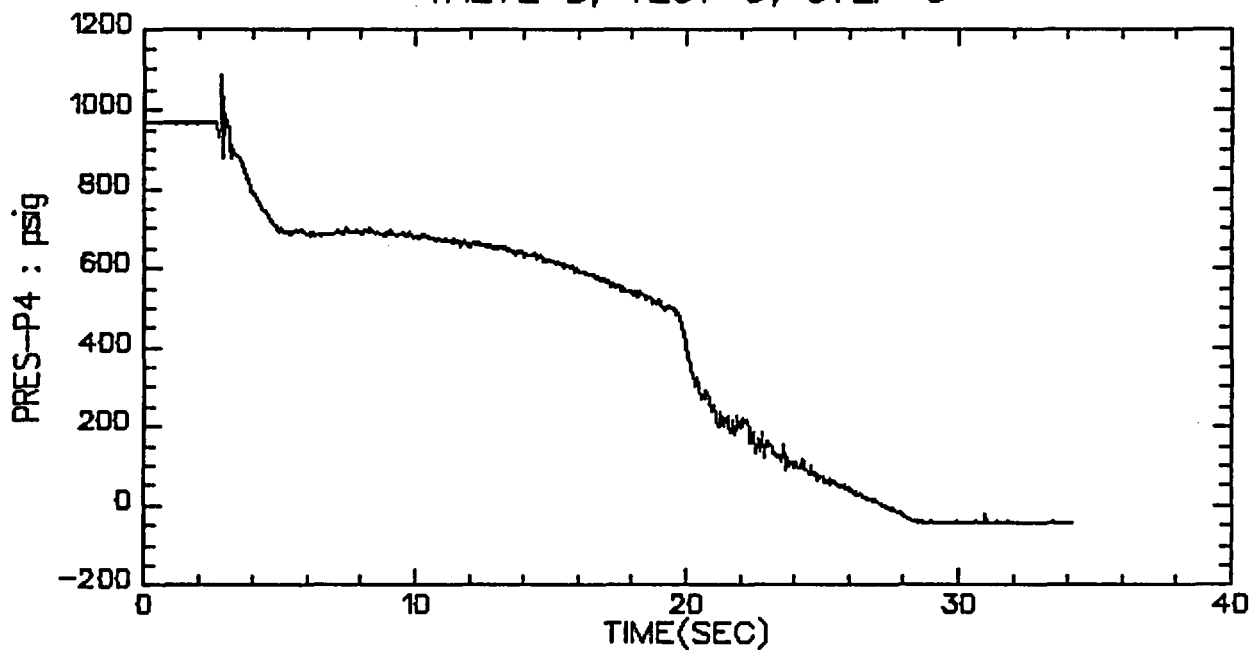

VALVE B, TEST 5, STEP 5

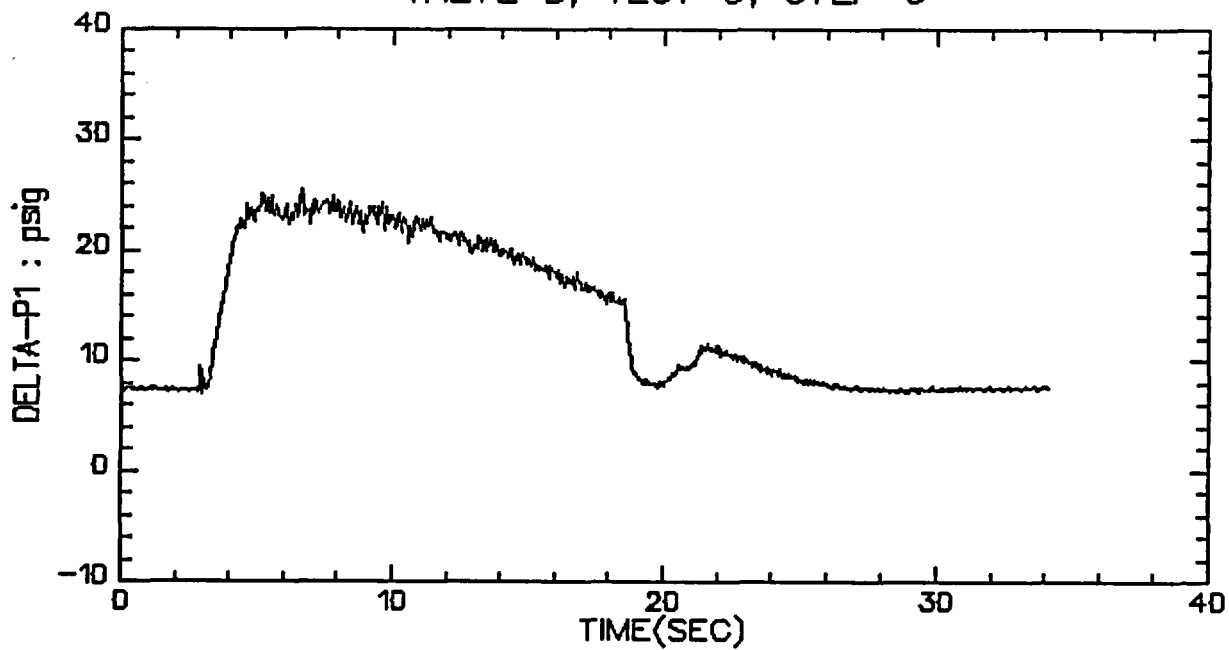

VALVE B, TEST 5, STEP 8&9

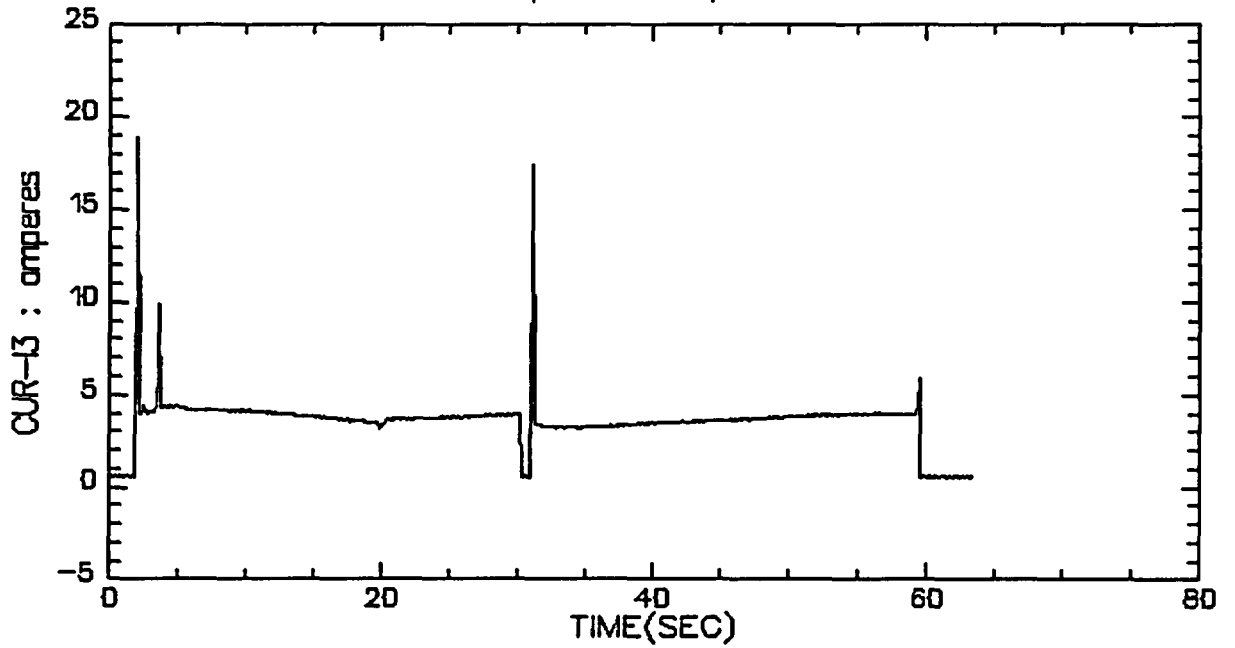

VALVE B, TEST 5, STEP 8&9

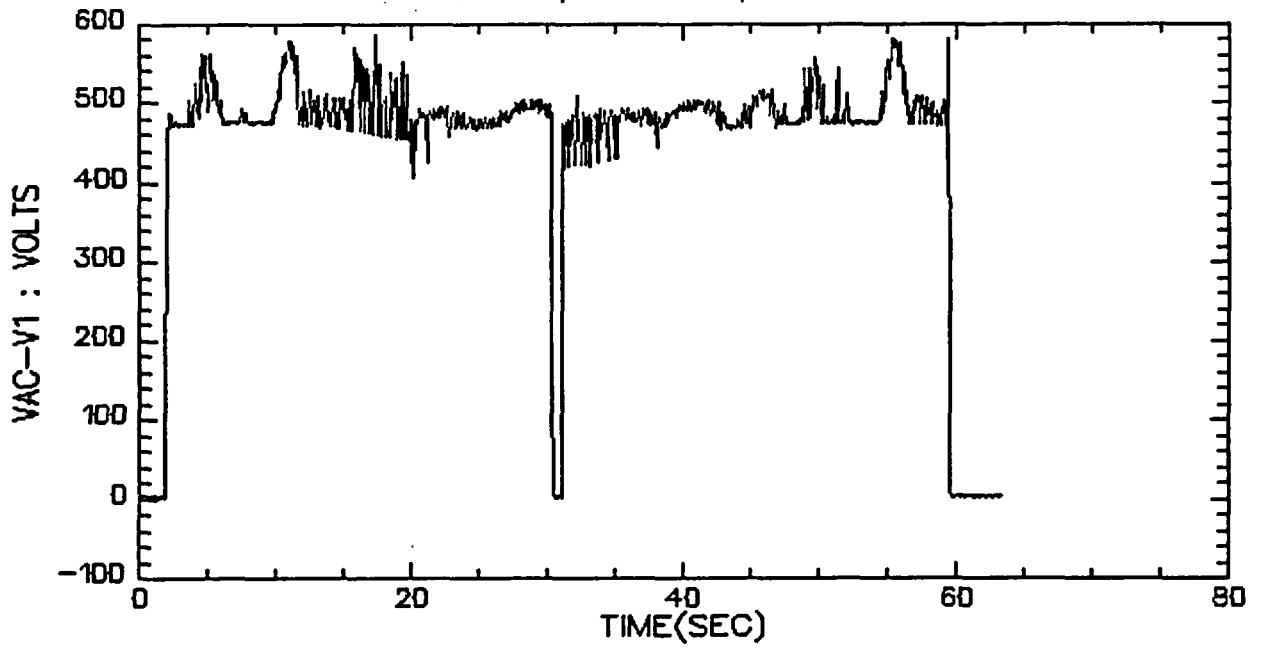

VALVE B, TEST 5, STEP 8&9

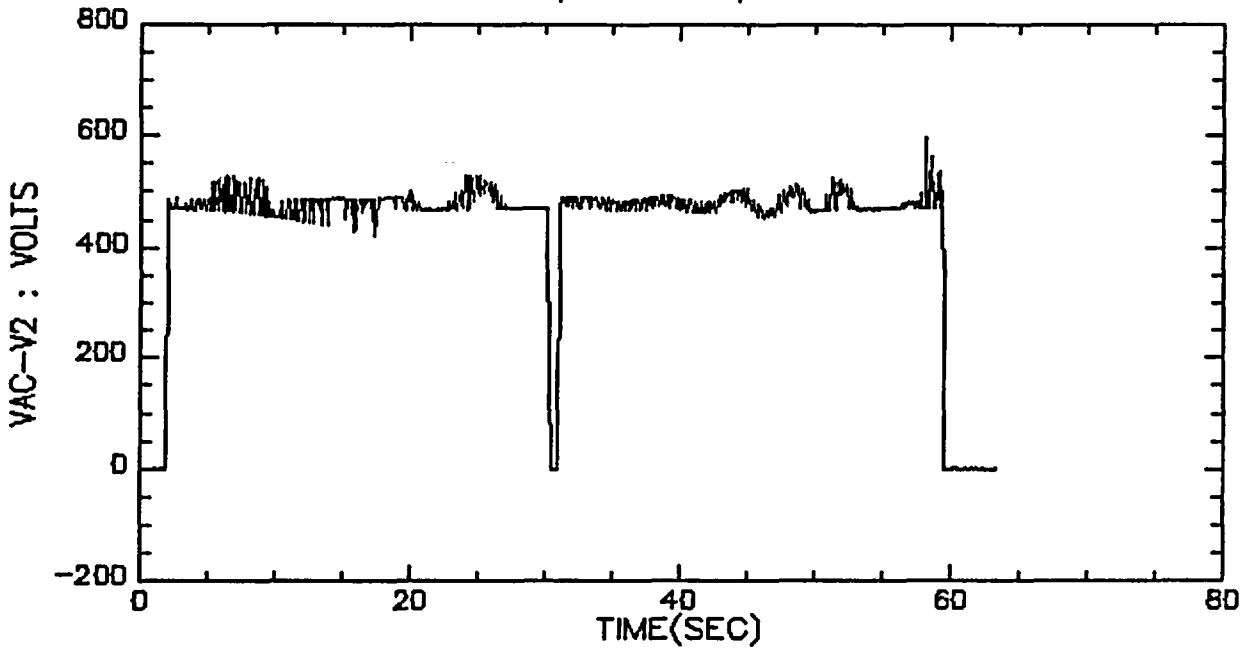

VALVE B, TEST 5, STEP 8&9

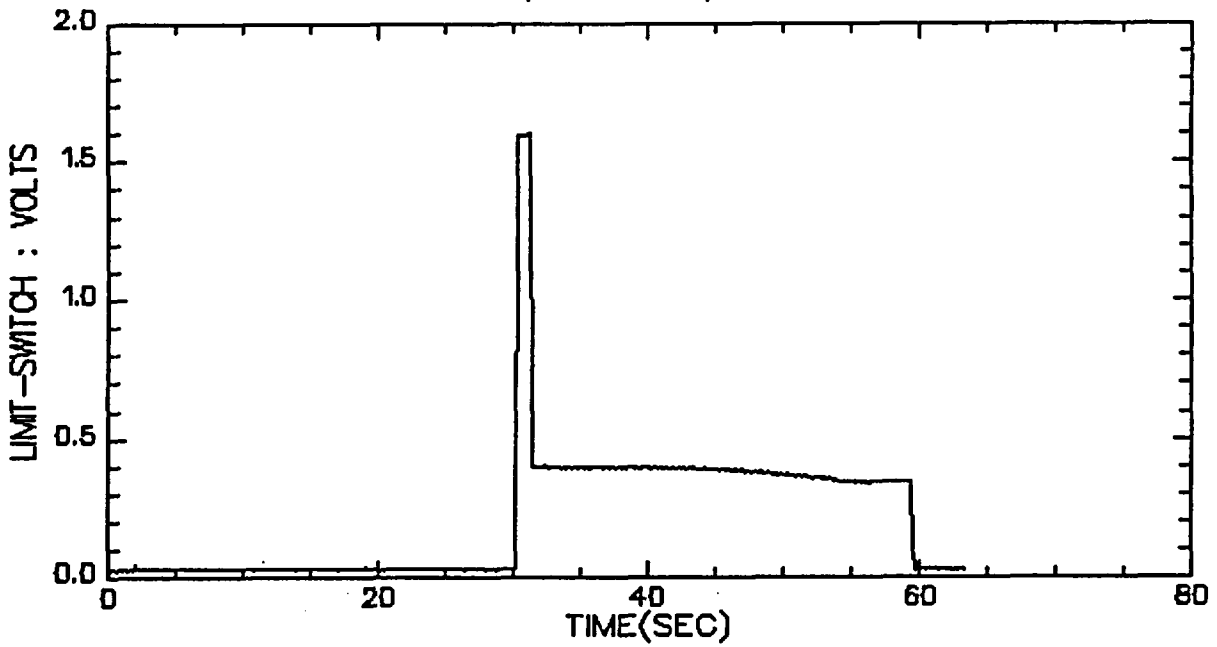

VALVE B, TEST 5, STEP 5

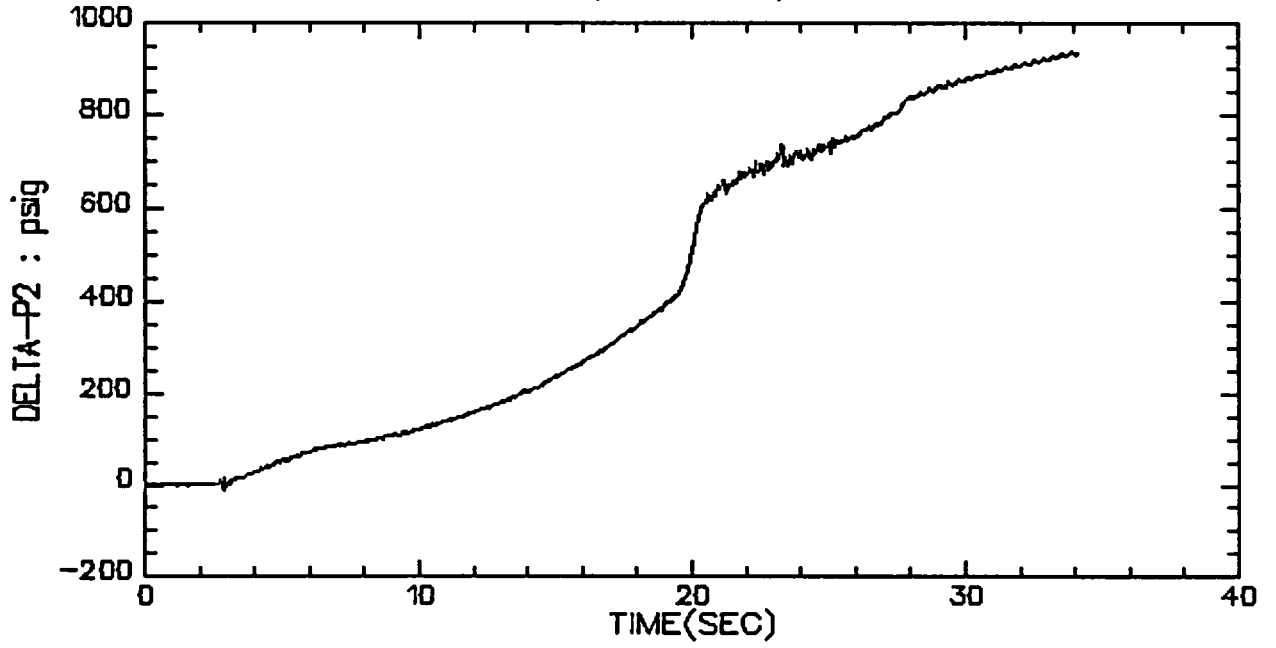

VALVE B, TEST 5, STEP 5

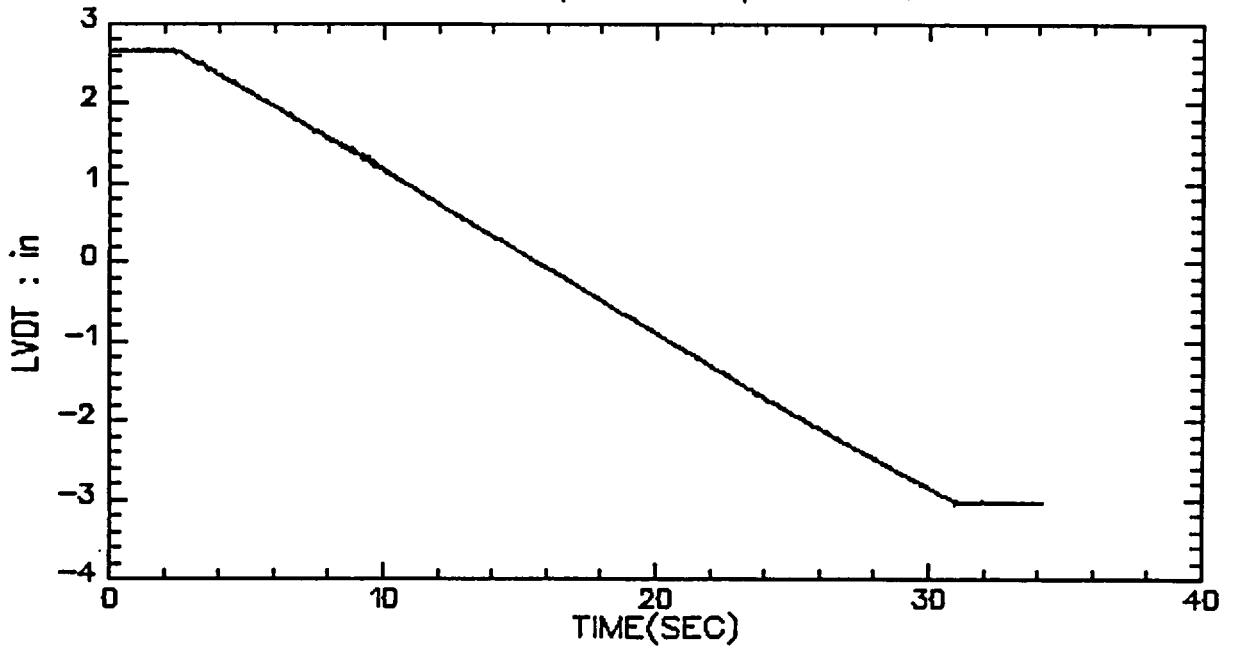

VALVE B, TEST 5, STEP 5

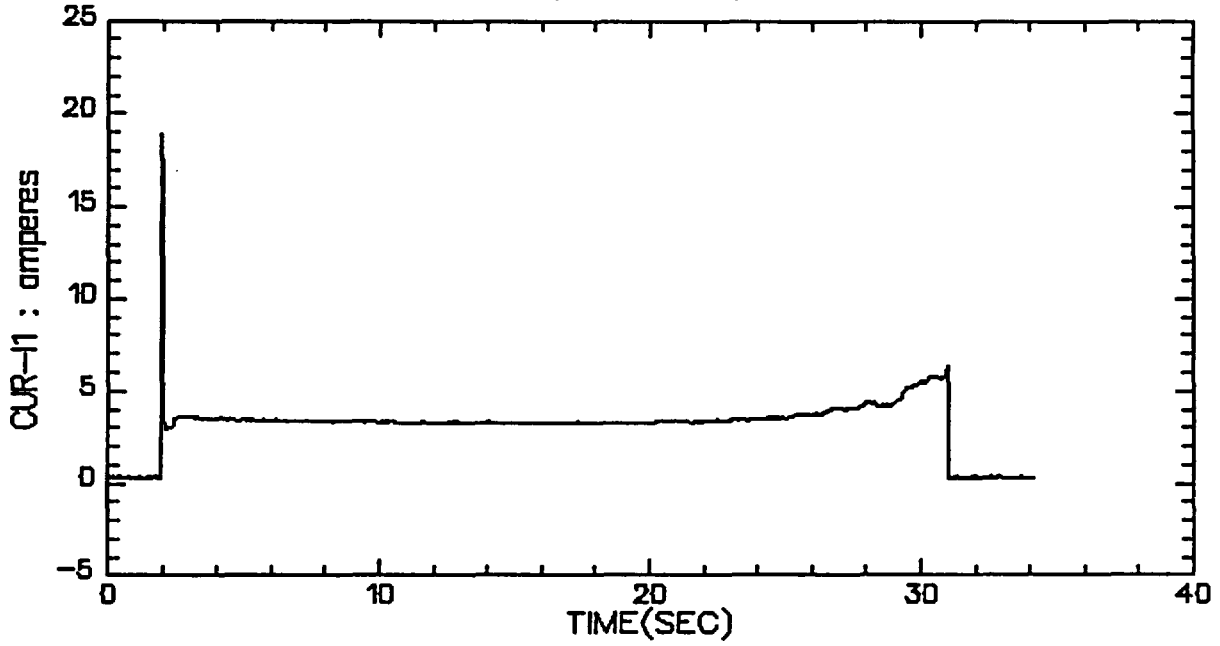

VALVE B, TEST 5, STEP 5

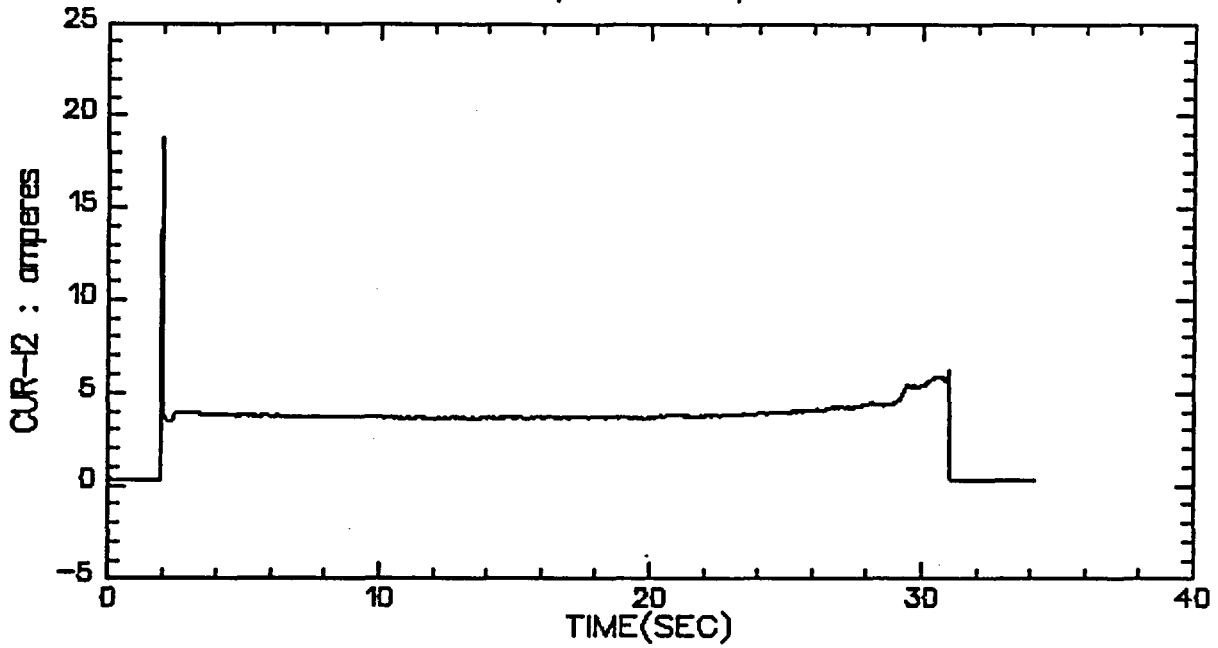

VALVE B, TEST 5, STEP 5

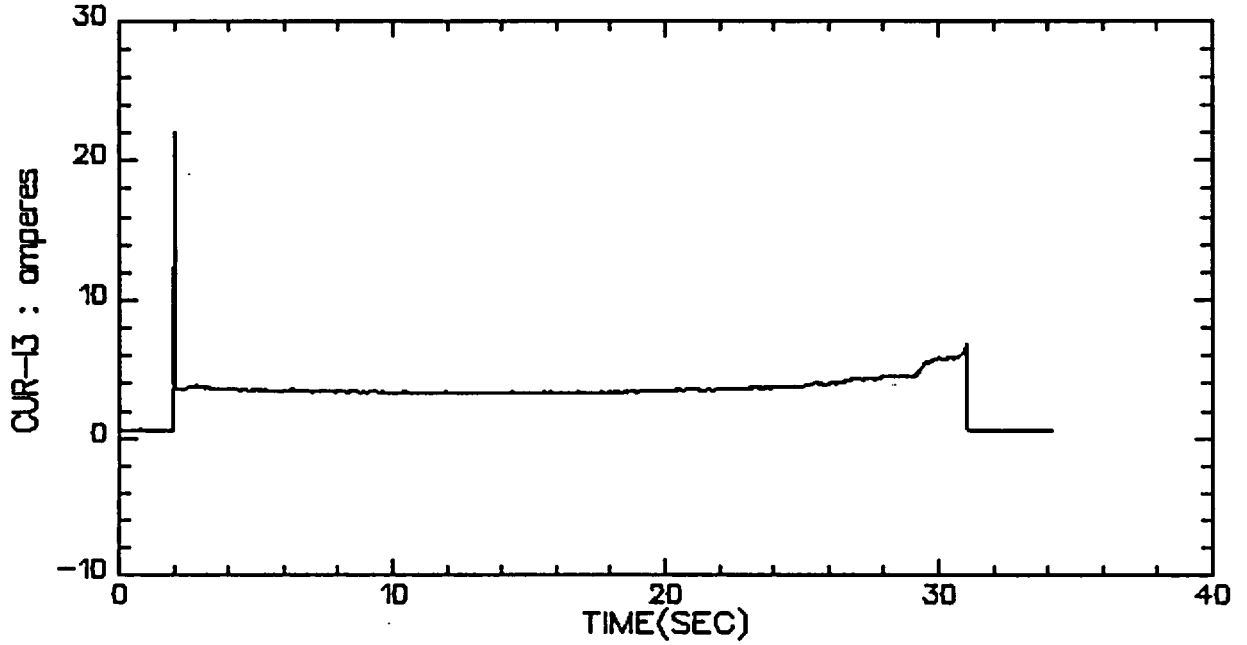

VALVE B, TEST 5, STEP 5

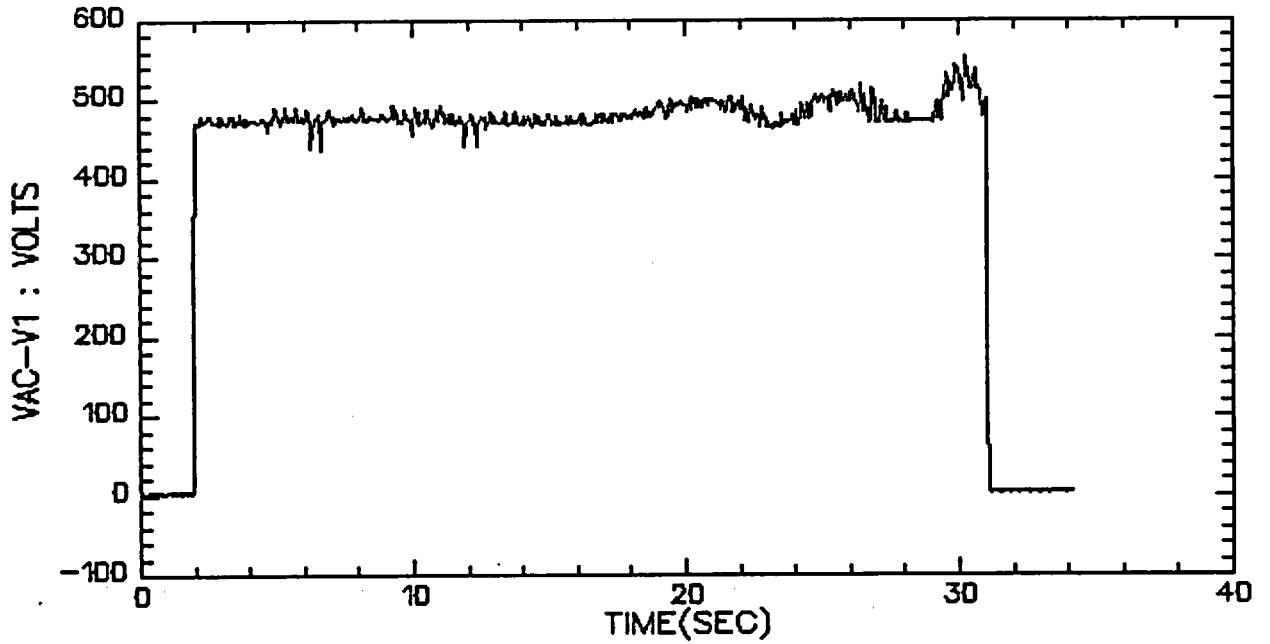

VALVE B, TEST 5, STEP 5

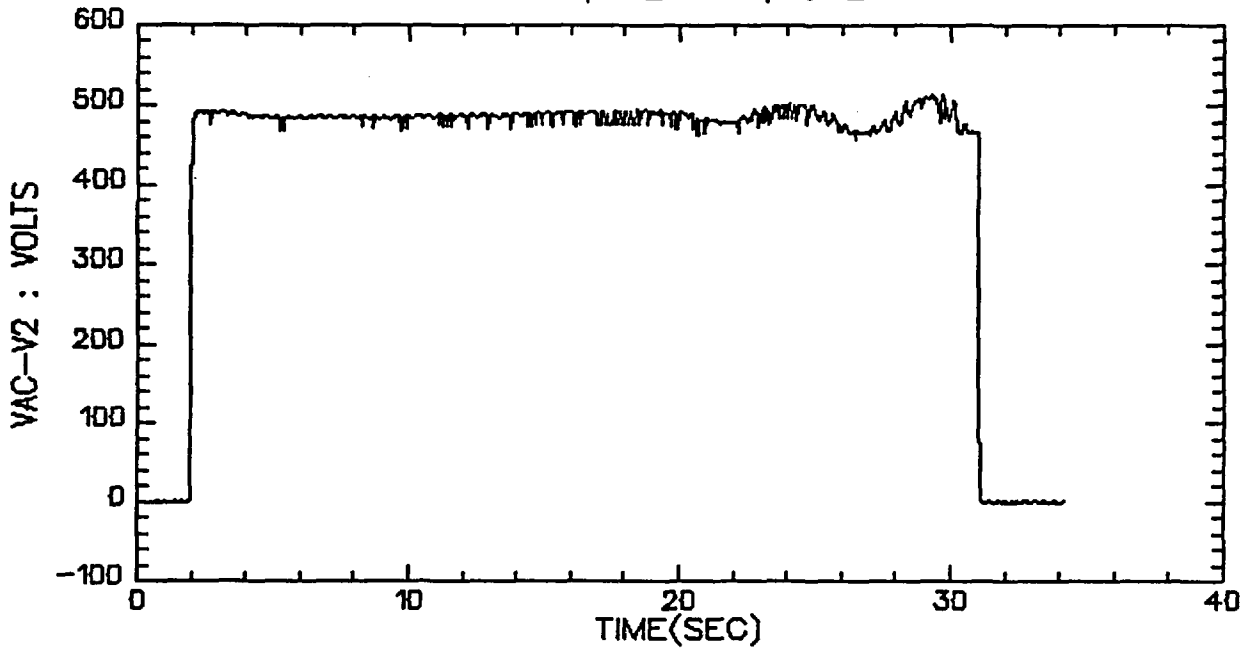

VALVE B, TEST 5, STEP 5

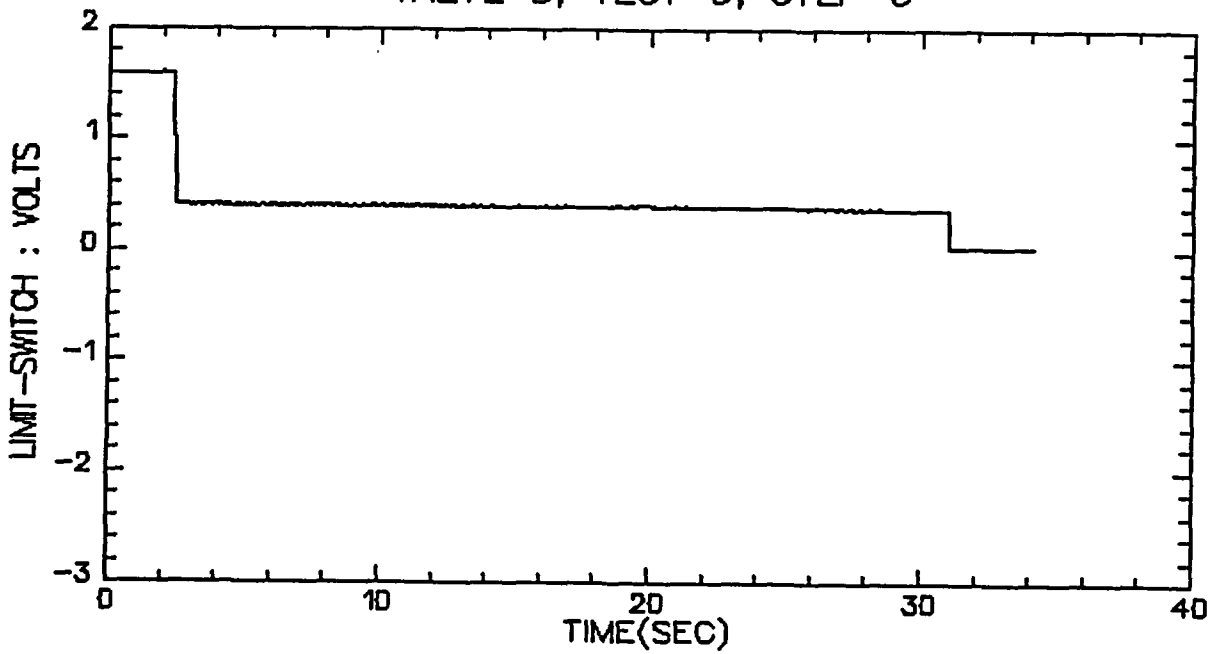

VALVE B, TEST 5, STEP 5

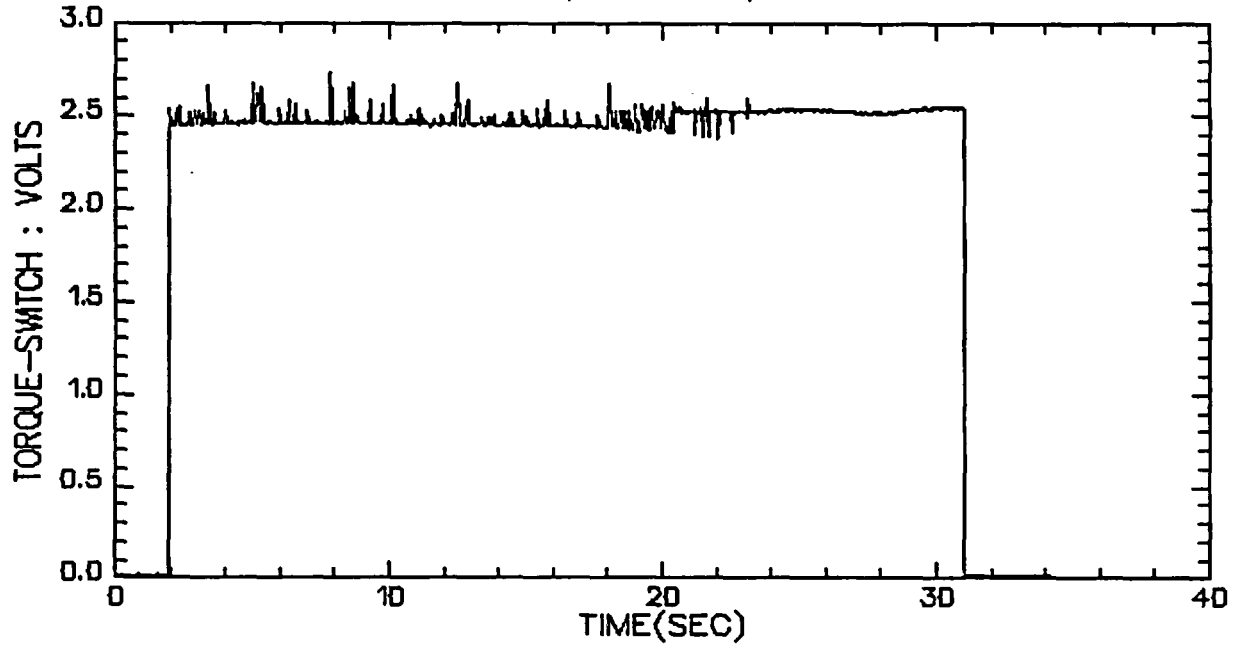

VALVE B, TEST 5, STEP 5

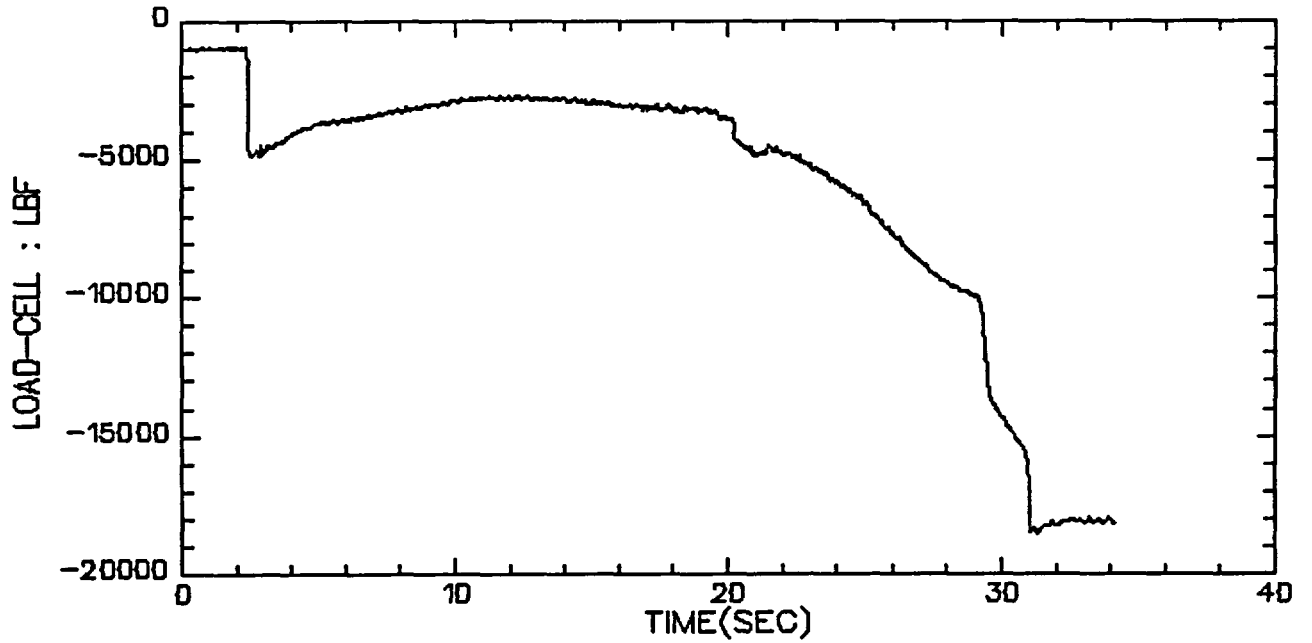

VALVE B, TEST 5, STEP 8&9

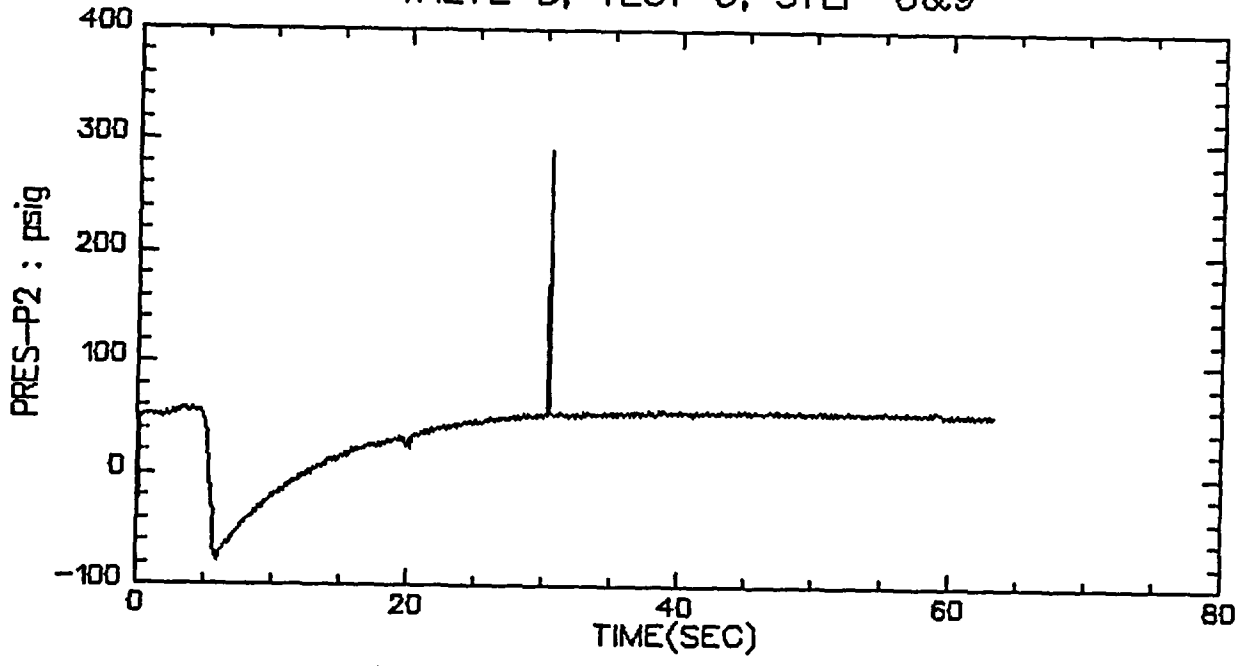

VALVE B, TEST 5, STEP 8&9

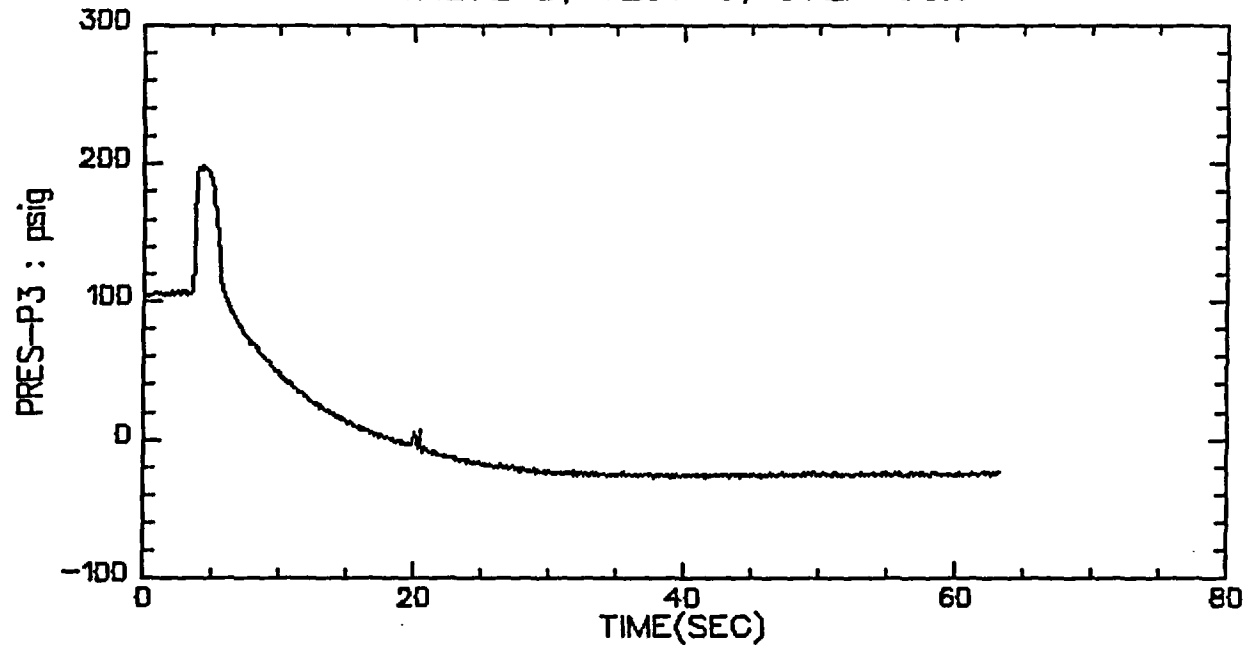

VALVE B, TEST 5, STEP 8&9

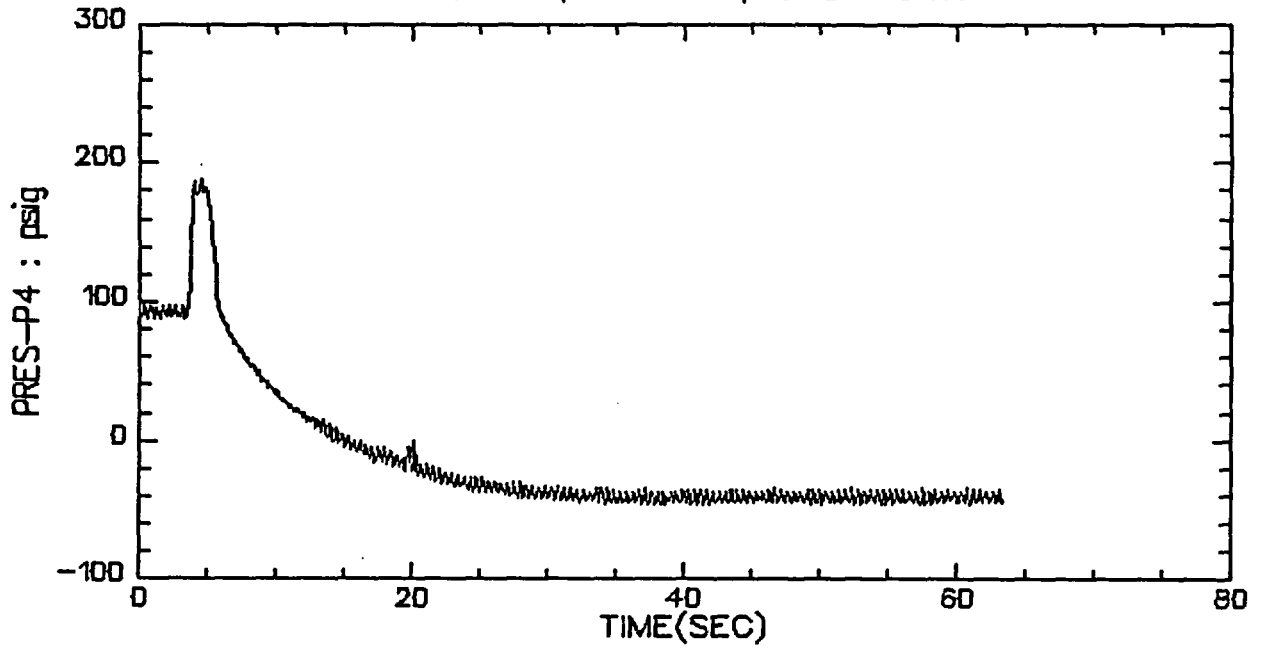

VALVE B, TEST 5, STEP 8&9

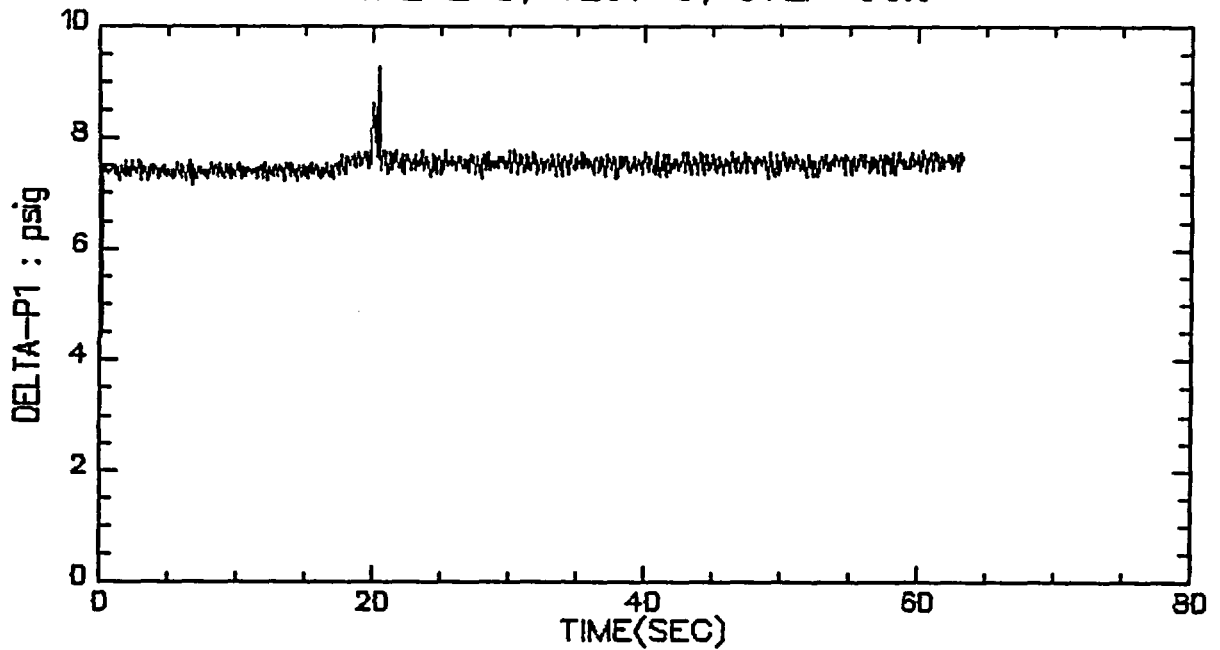

VALVE B, TEST 5, STEP 8&9

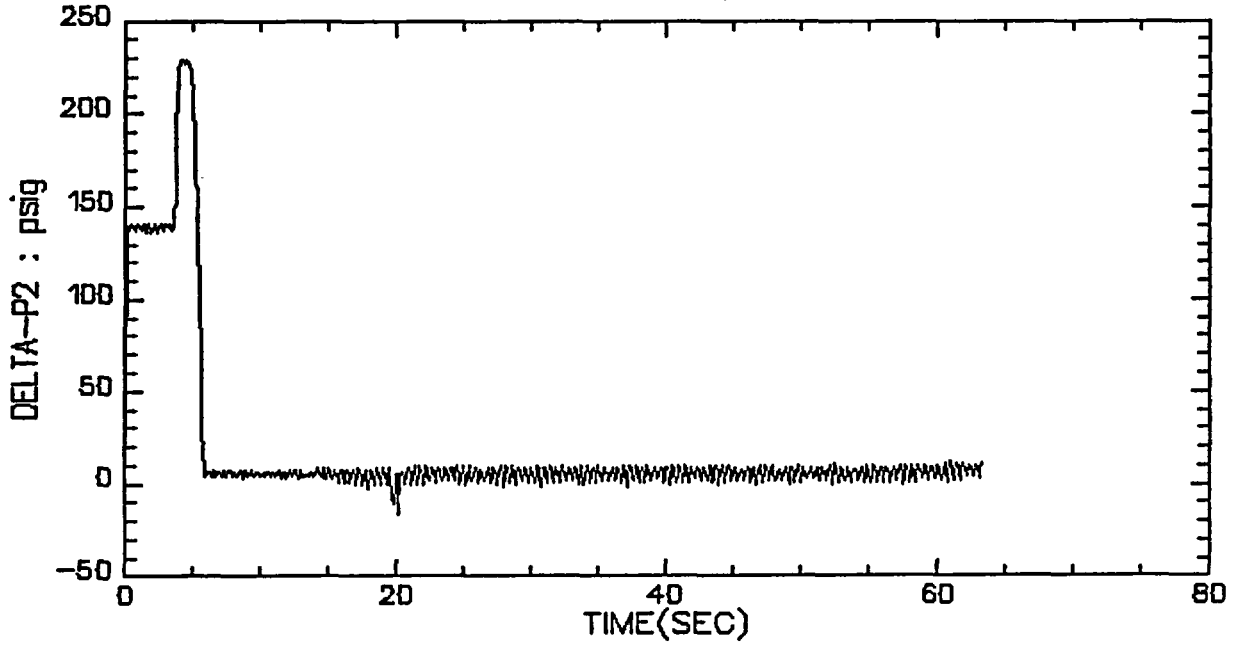

VALVE B, TEST 5, STEP 8&9

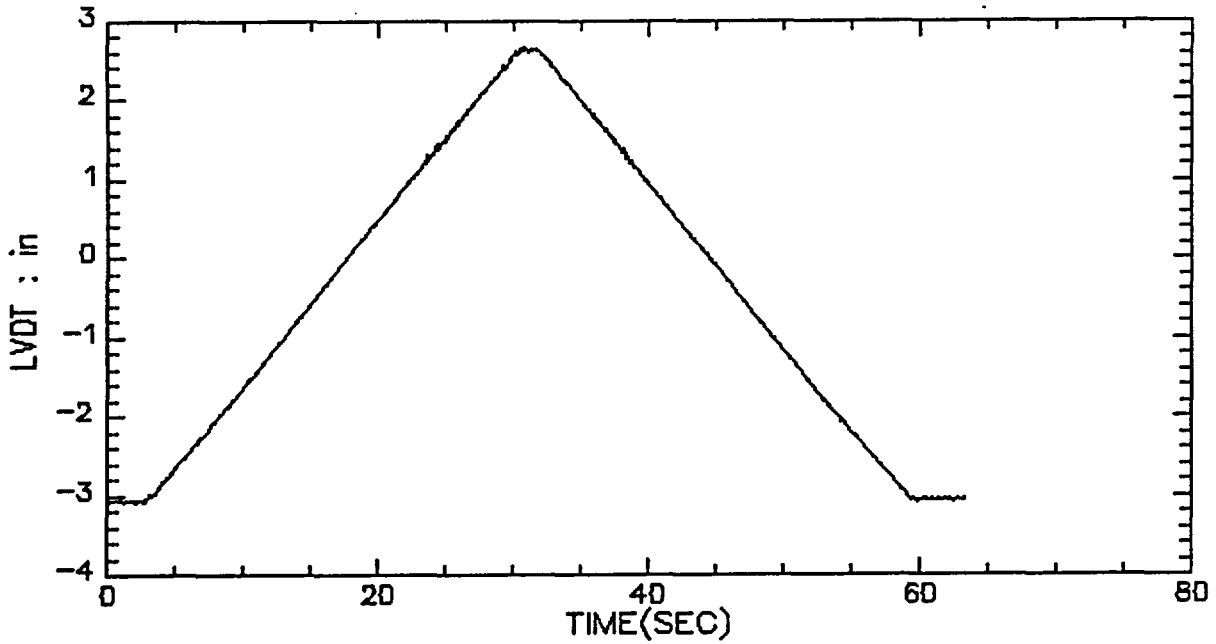

VALVE B, TEST 5, STEP 8&9

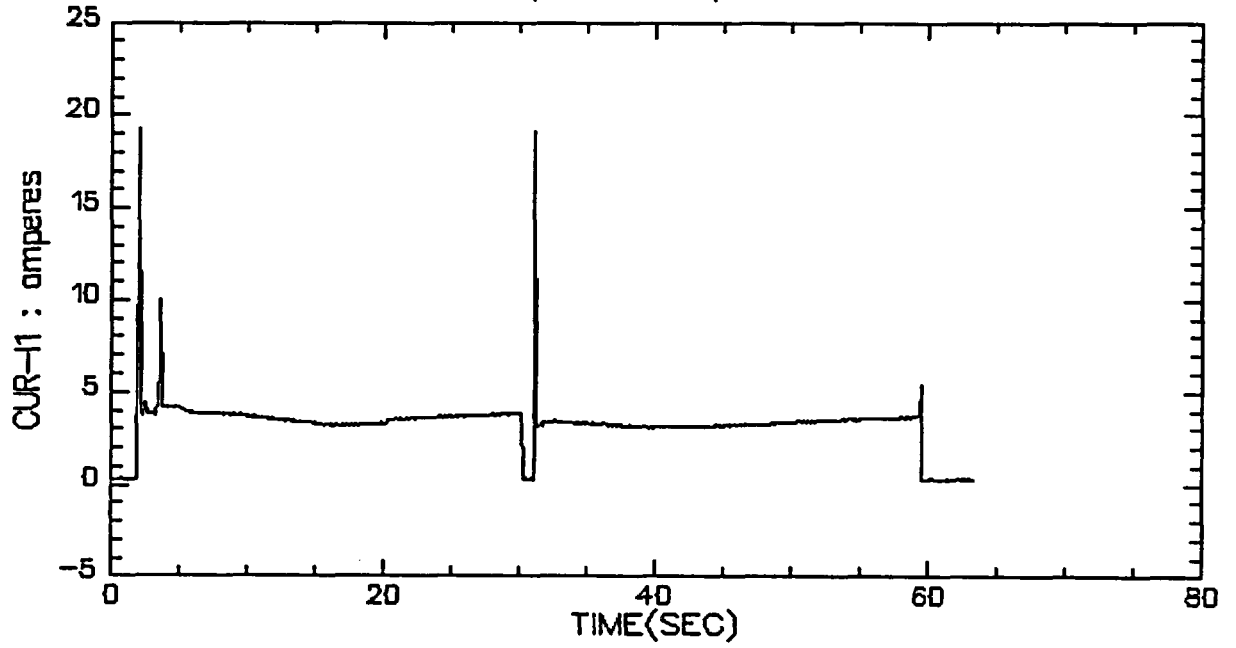

VALVE B, TEST 5, STEP 8&9

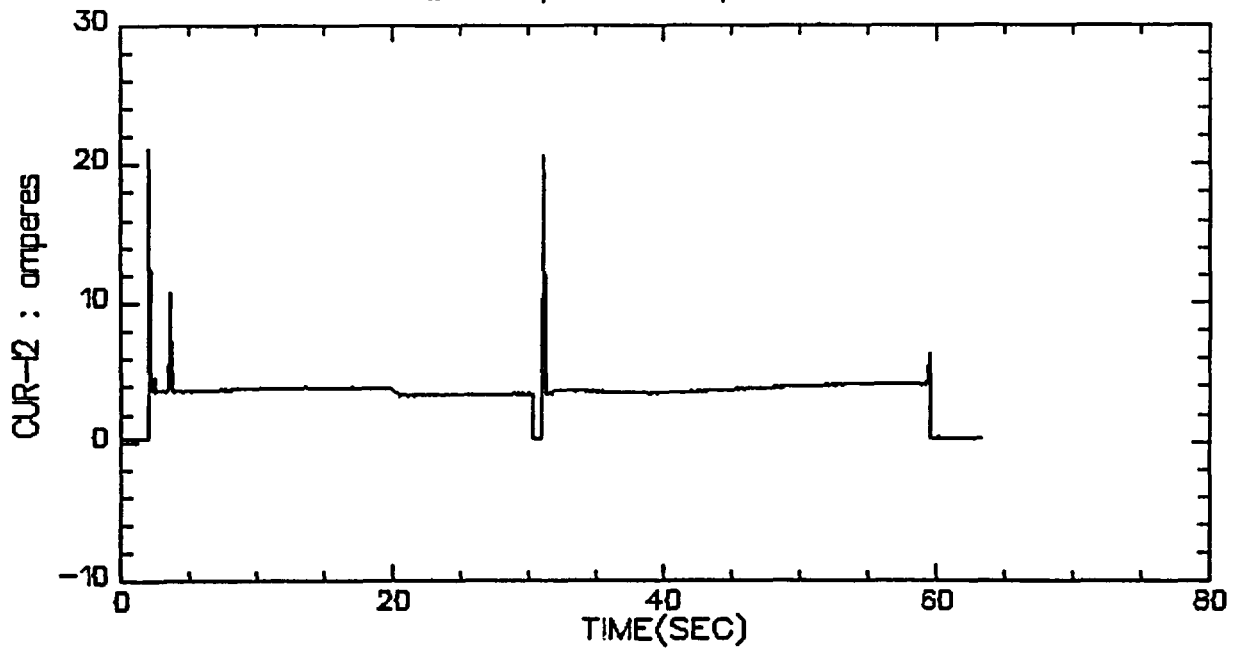

VALVE B, TEST 5, STEP 8&9

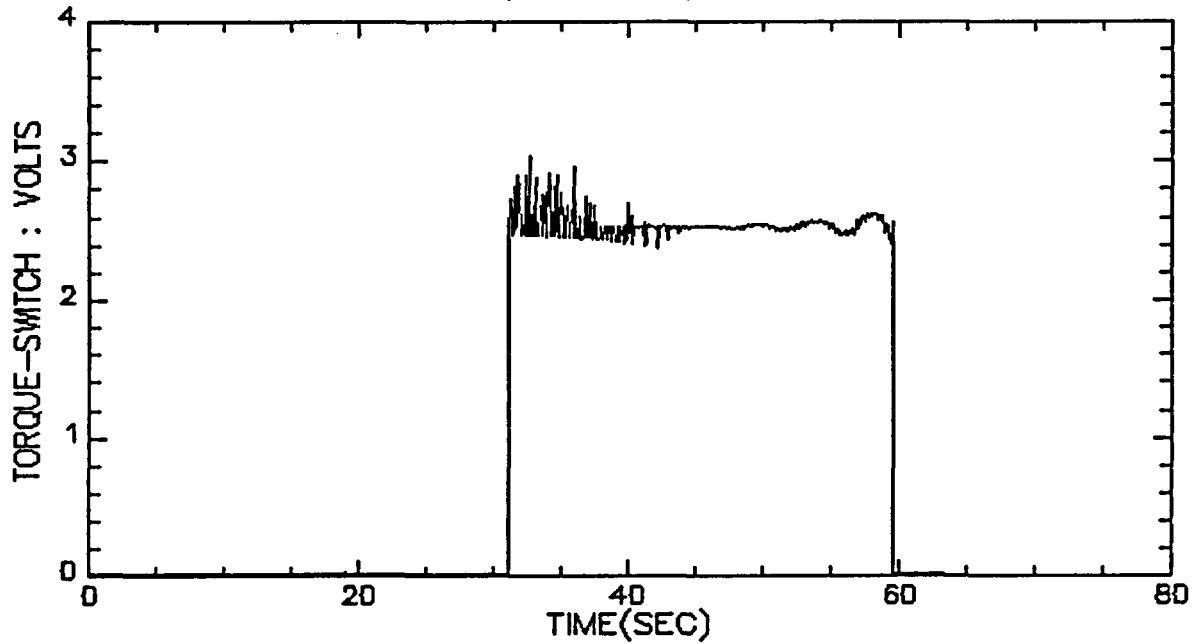

VALVE B, TEST 5, STEP 8&9

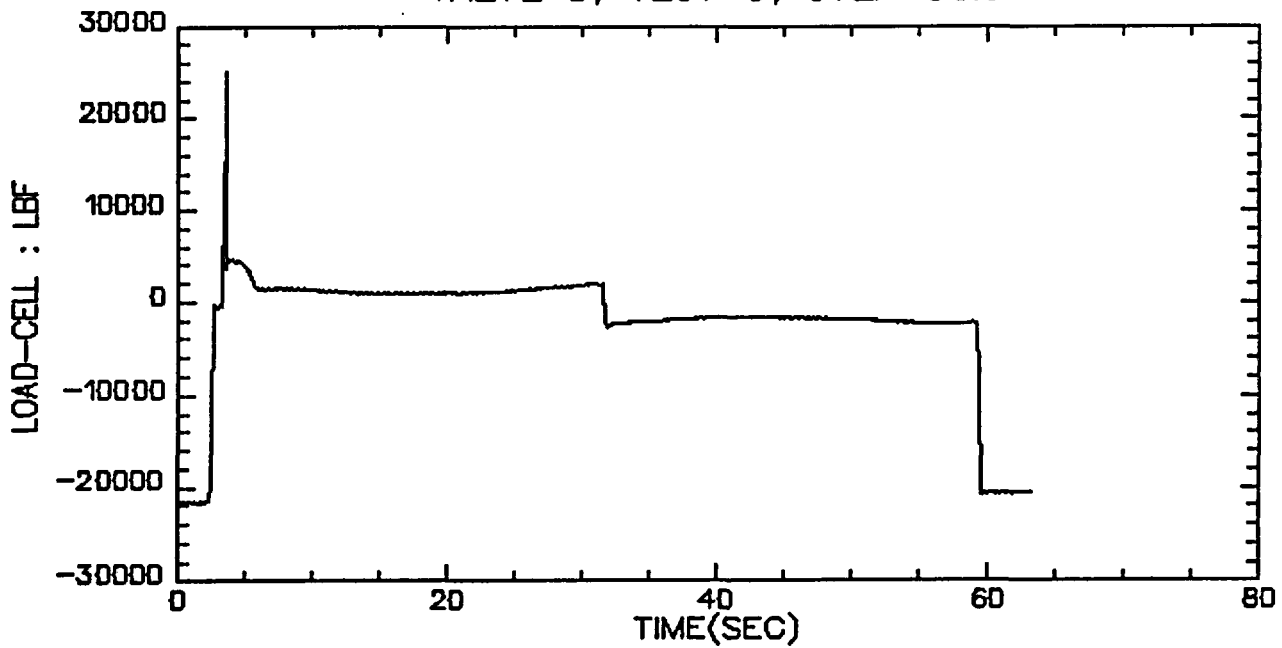

VALVE B, TEST 5, STEP 17

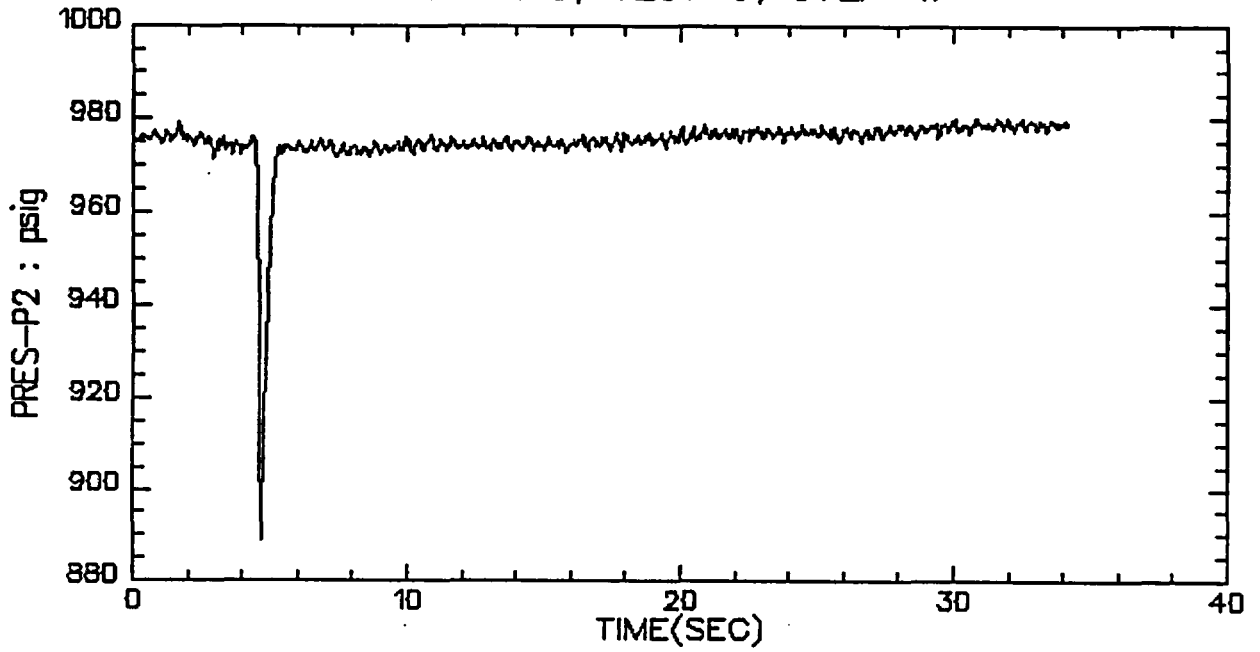

VALVE B, TEST 5, STEP 17

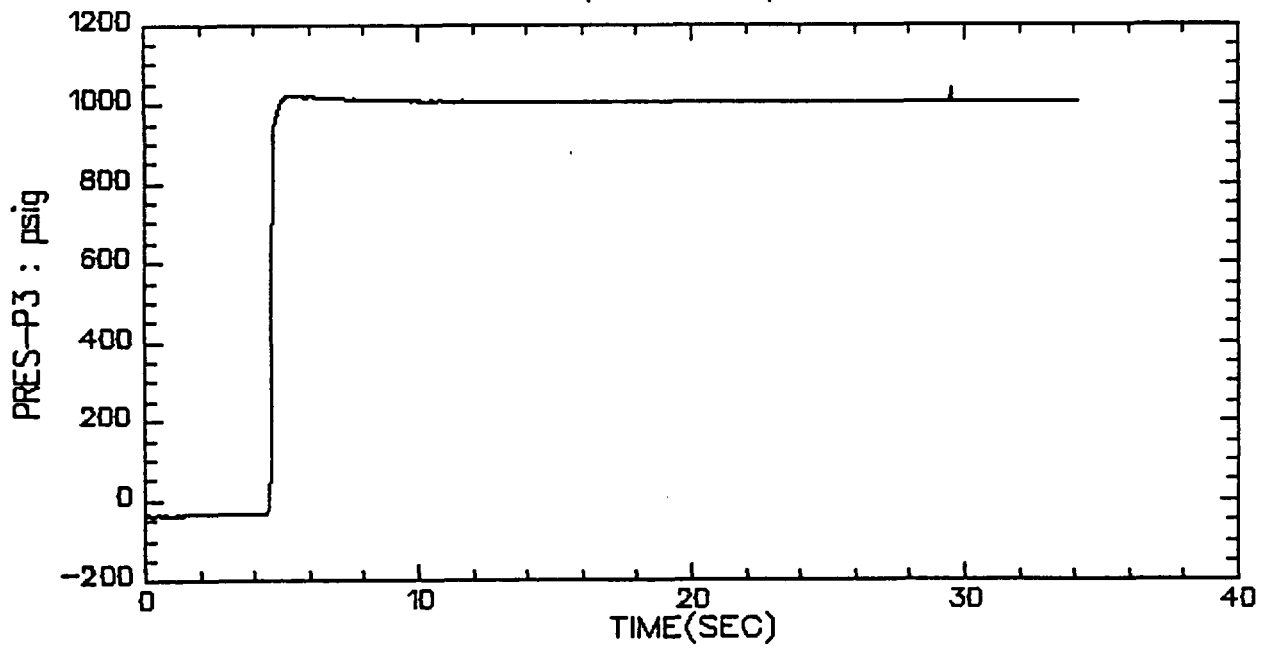

VALVE B, TEST 5, STEP 17

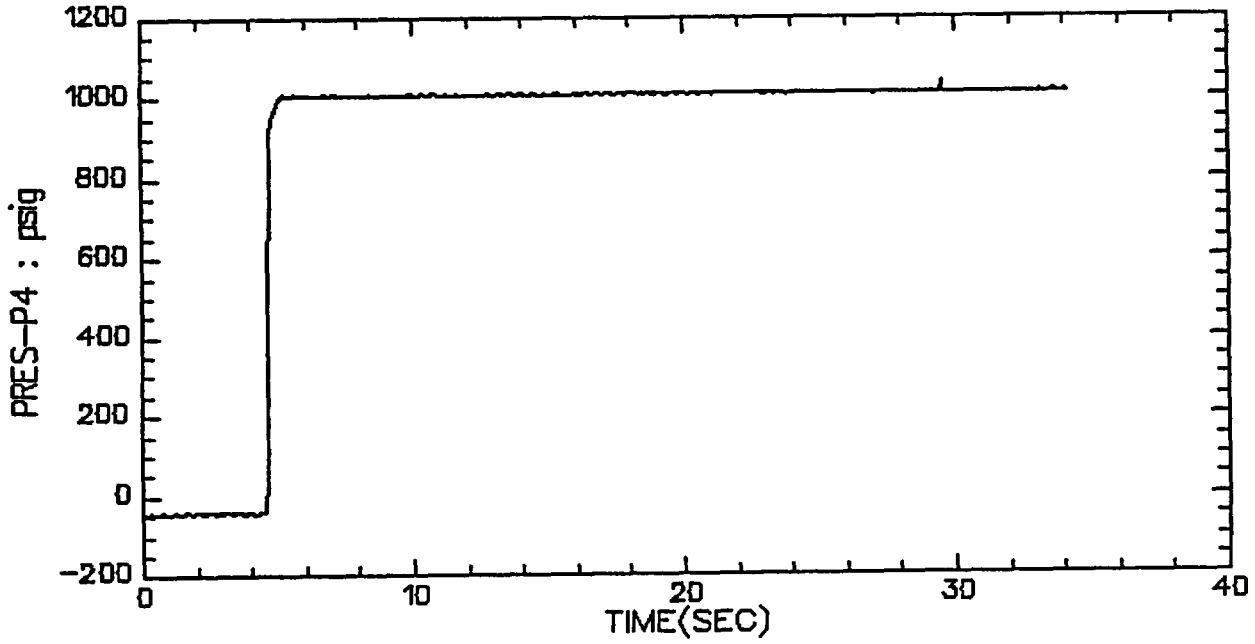

VALVE B, TEST 5, STEP 17

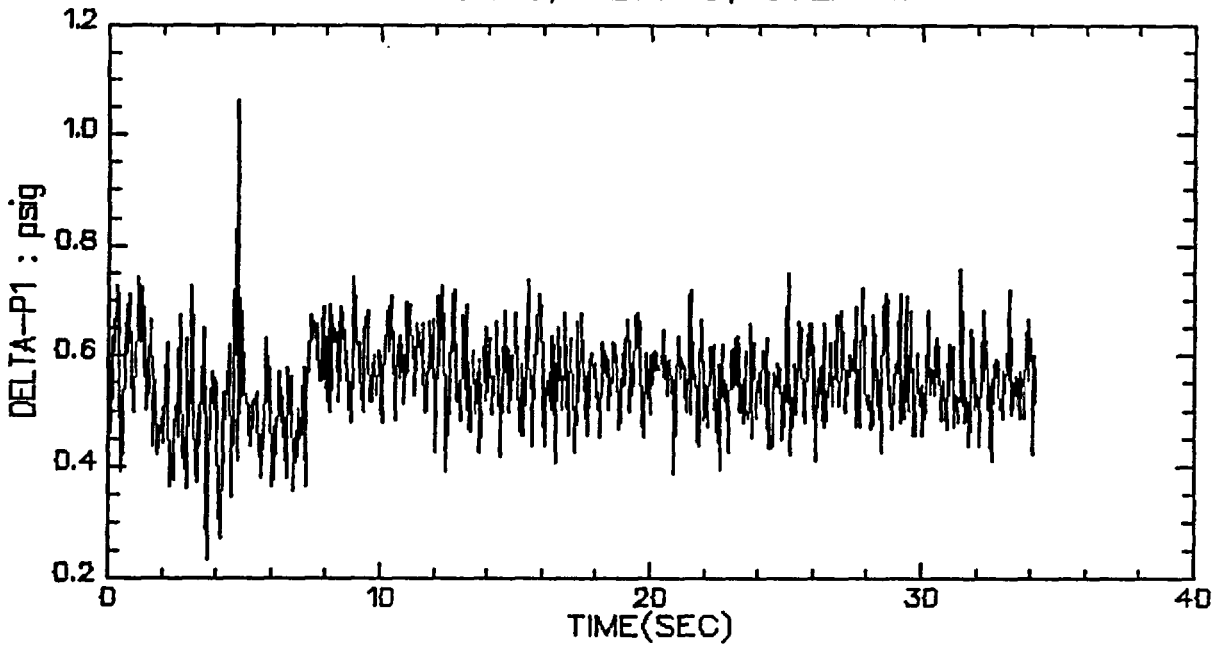

VALVE B, TEST 5, STEP 17

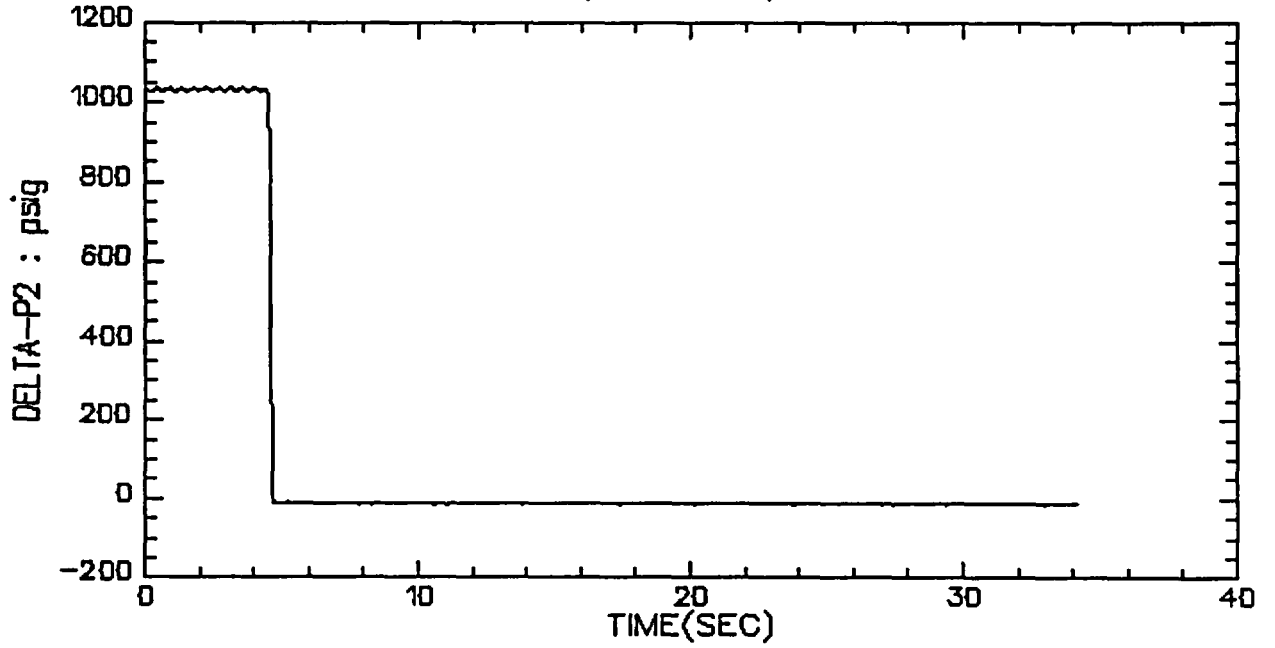

VALVE B, TEST 5, STEP 17

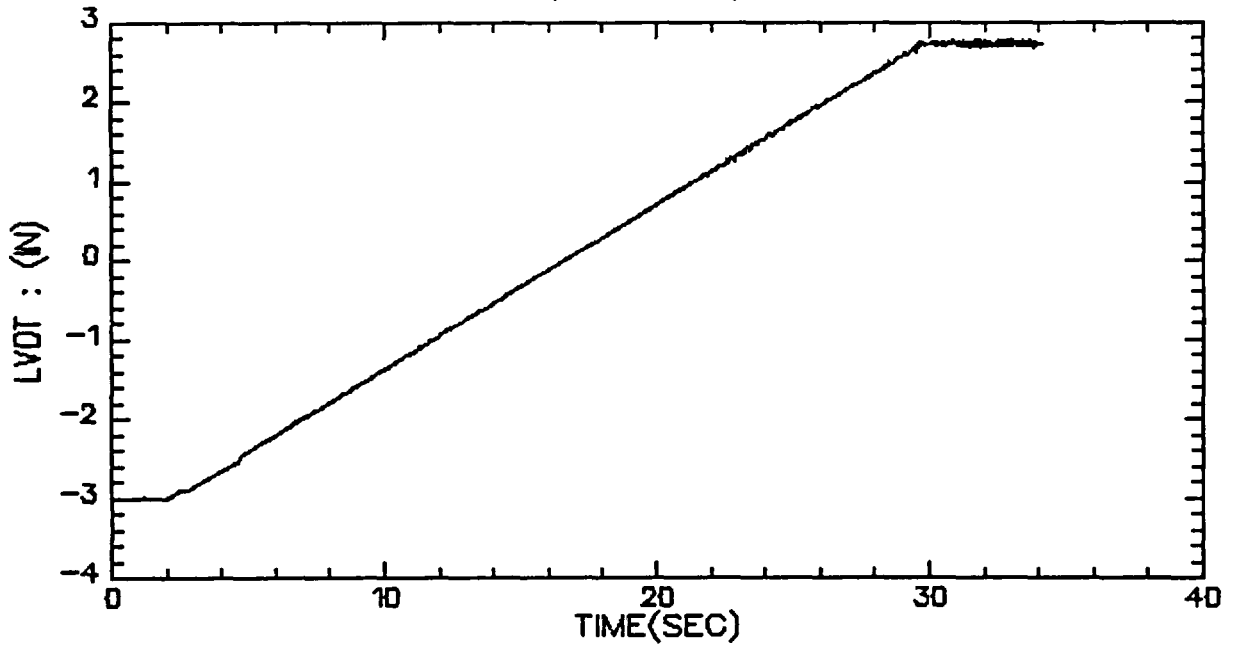

VALVE B, TEST 5, STEP 17

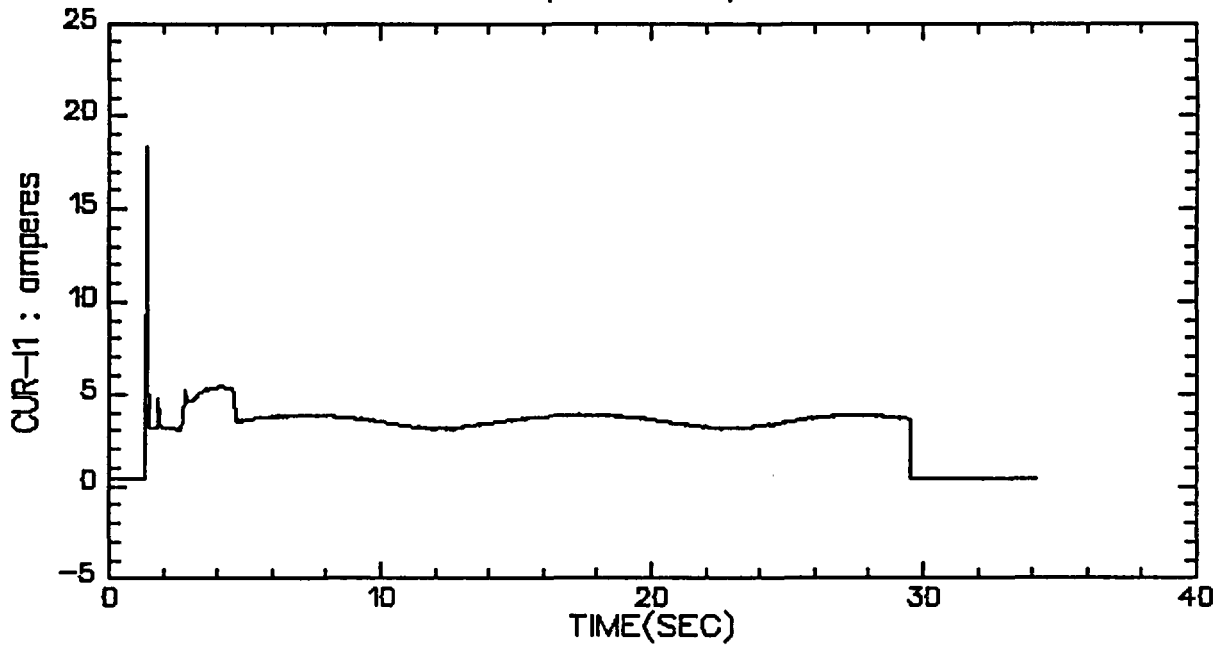

VALVE B, TEST 5, STEP 17

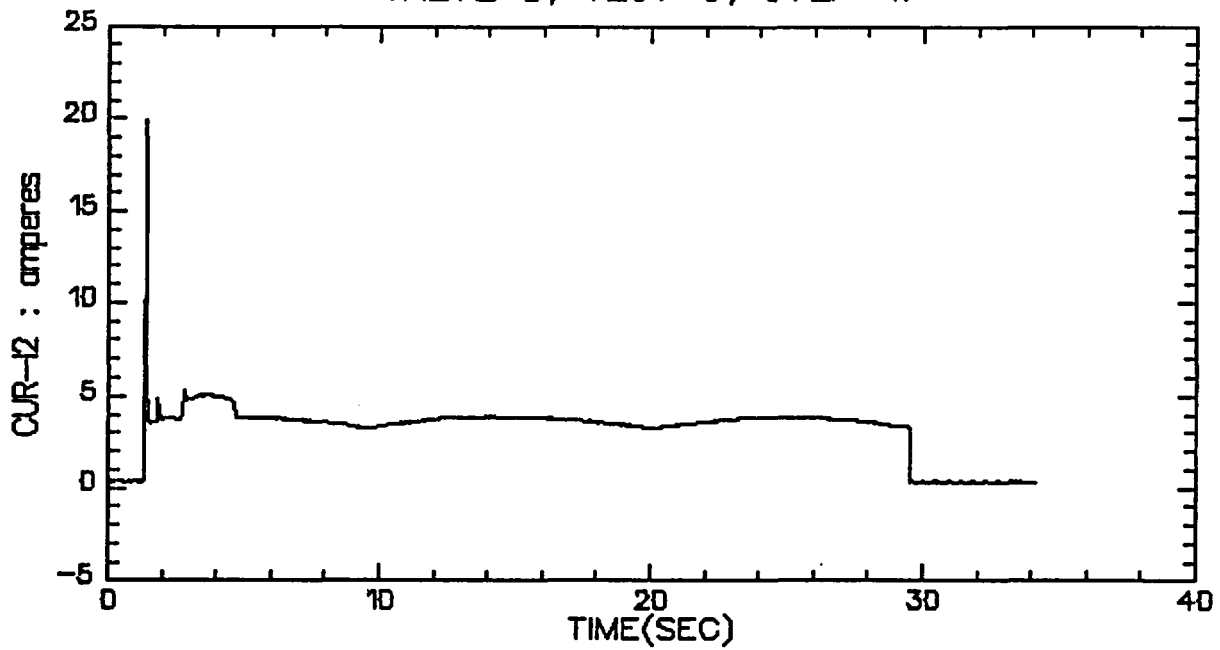

VALVE B, TEST 5, STEP 17

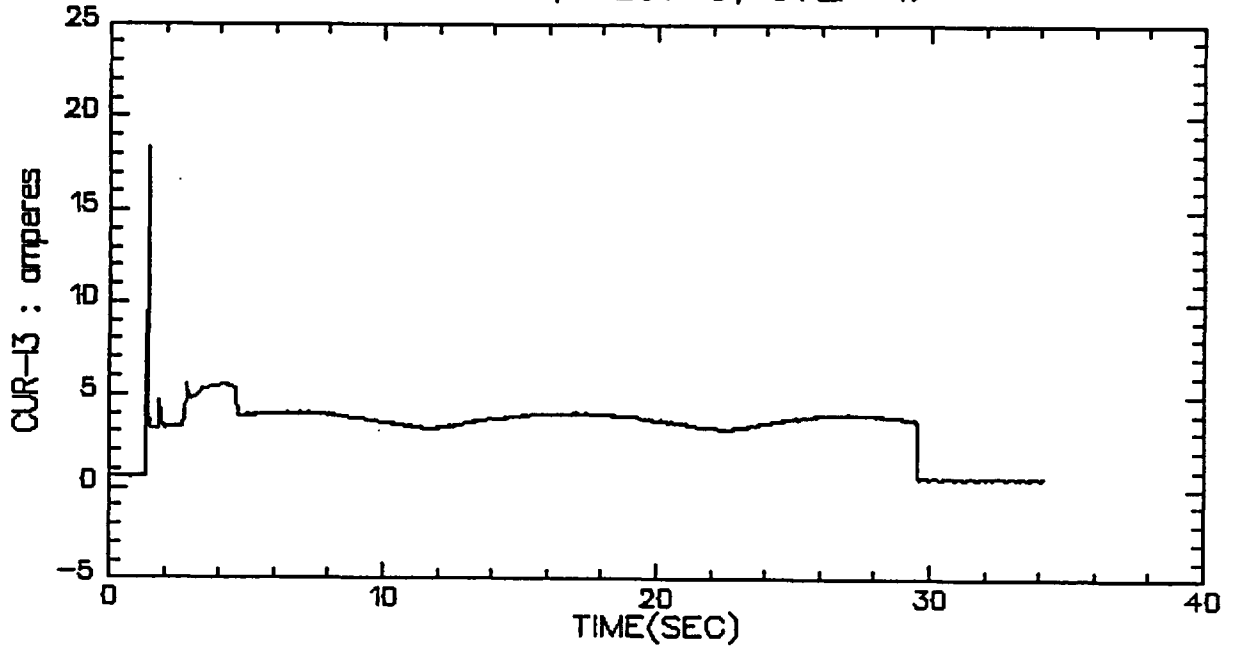

VALVE B, TEST 5, STEP 17

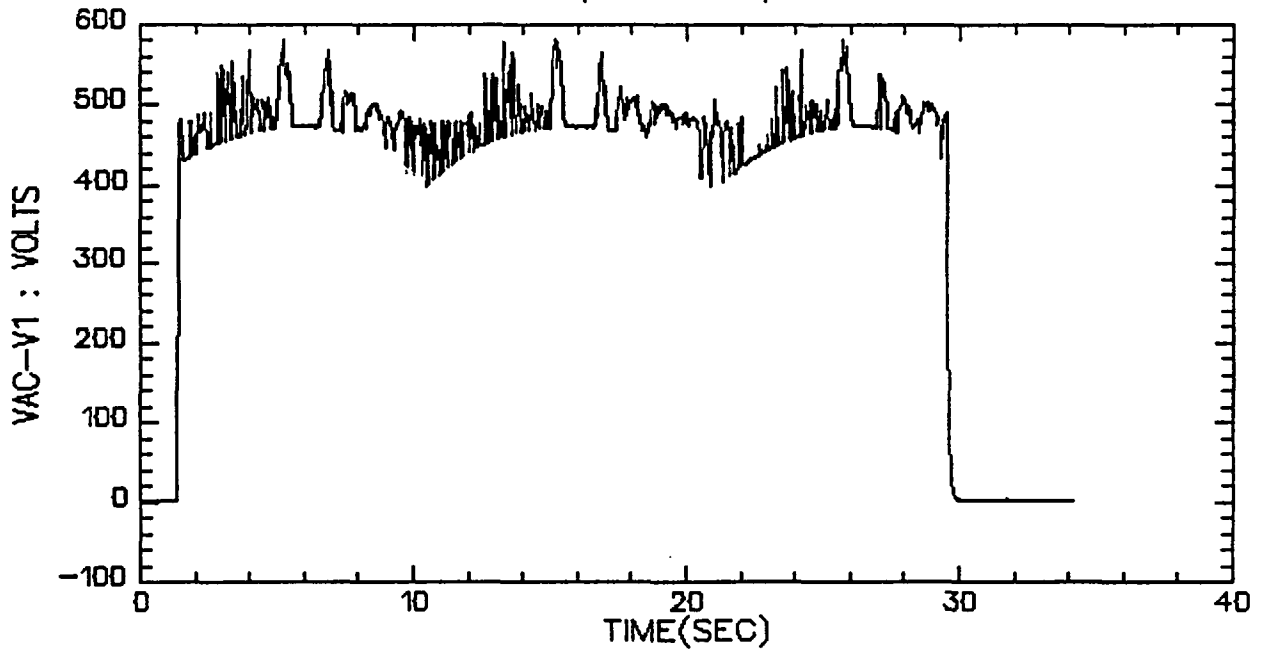

VALVE B, TEST 5, STEP 17

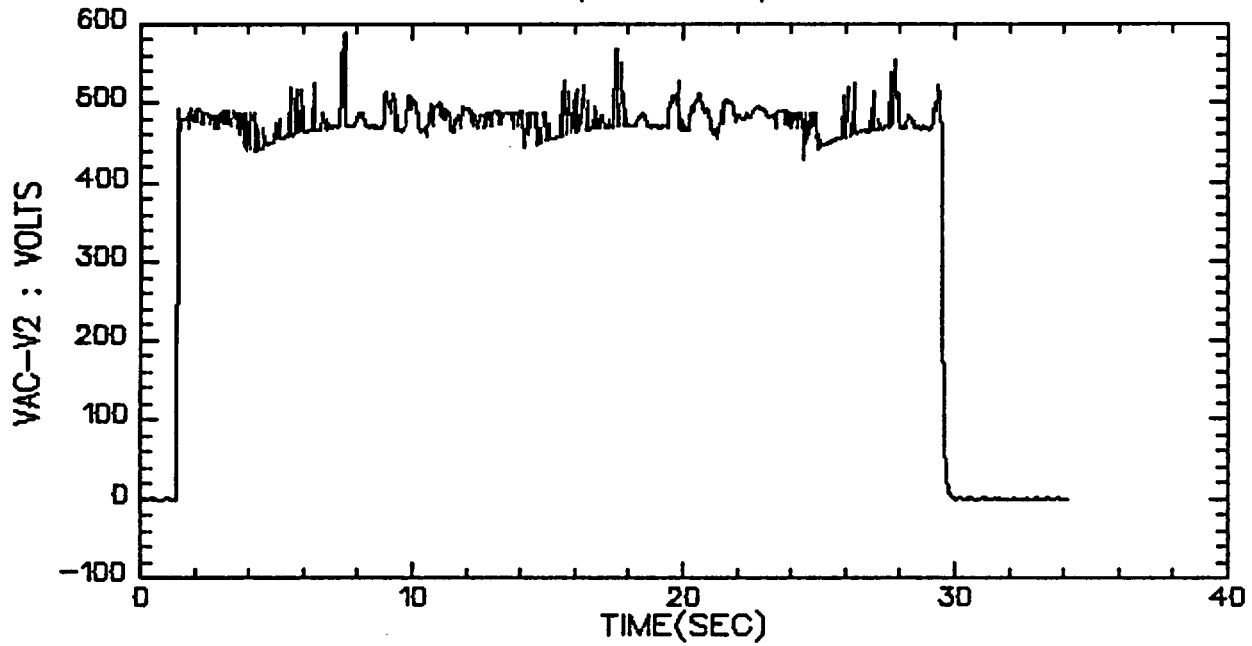

VALVE B, TEST 5, STEP 17

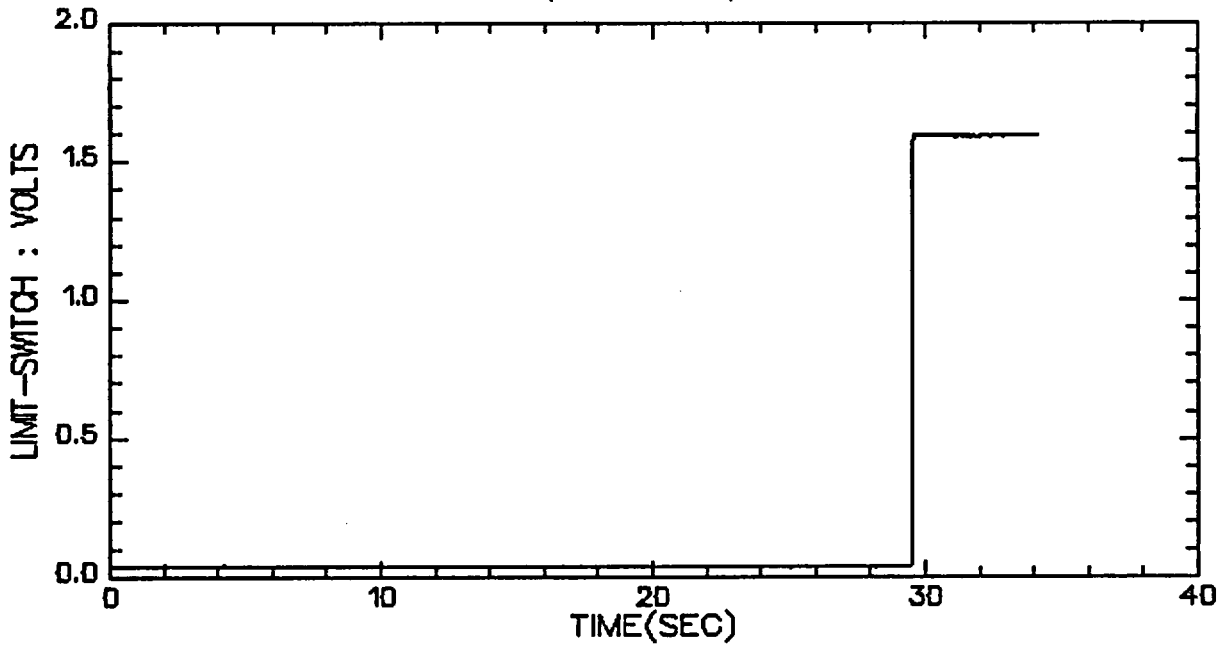

VALVE B, TEST 5, STEP 17

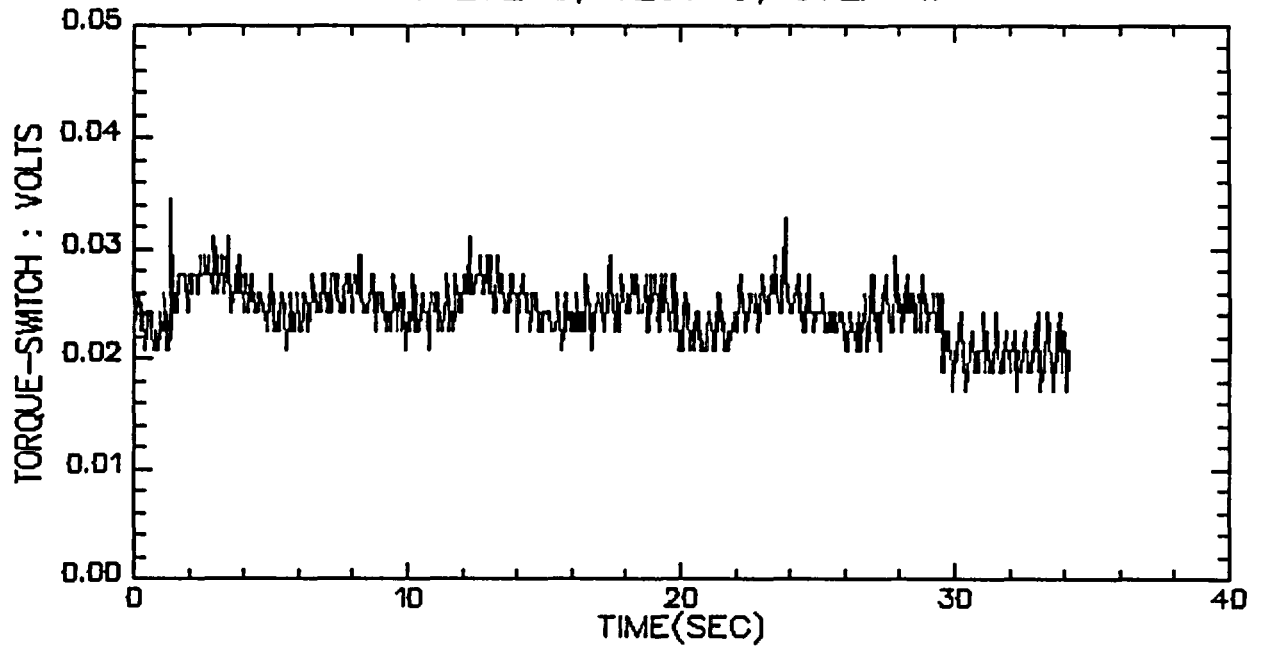

VALVE B, TEST 5, STEP 17

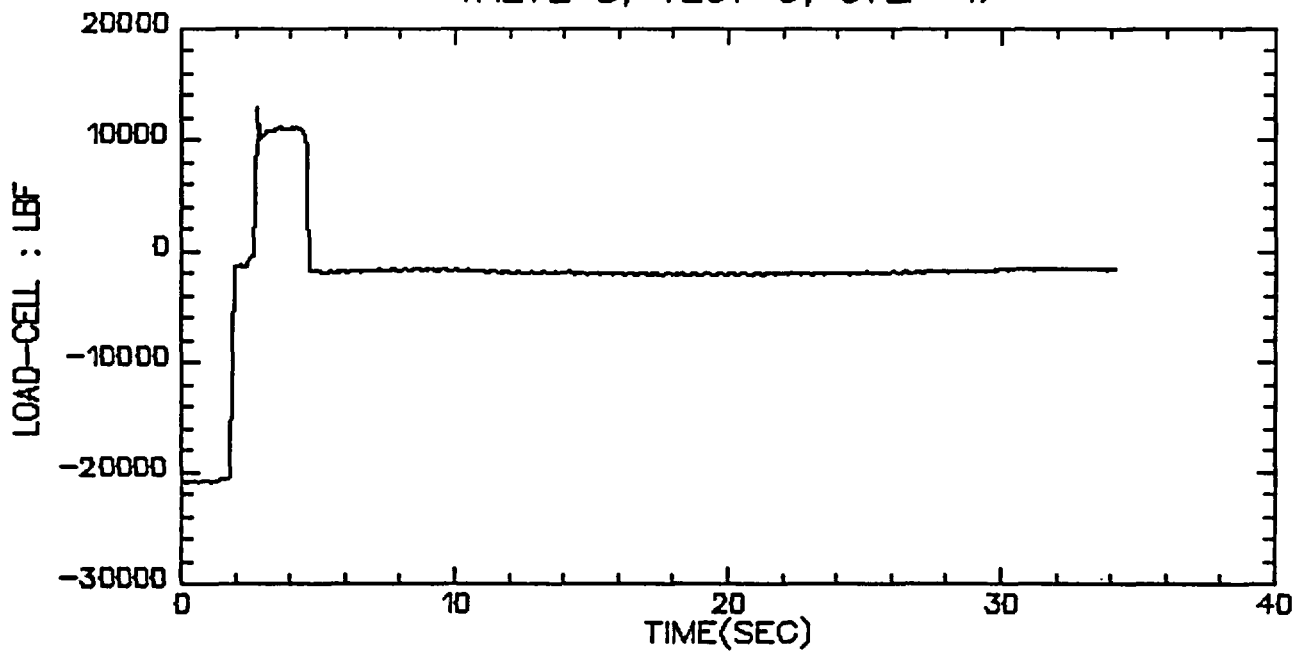

NRC FORM 335 (2-89) NRCM 1102, 3201, 3202		U.S. NUCLEAR REGULATORY COMMISSION	
BIBLIOGRAPHIC DATA SHEET <i>(See instructions on the reverse)</i>		1. REPORT NUMBER (Assigned by NRC, Add Vol., Supp., Rev., and Addendum Numbers, if any.) NUREG/CR-5406 EGG-2569 Vol. 2	
2. TITLE AND SUBTITLE BWR Reactor Water Cleanup System Flexible Wedge Gate Isolation Valve Qualification and High Energy Flow Interruption Test Data Report		3. DATE REPORT PUBLISHED MONTH YEAR October 1989	
		4. FIN OR GRANT NUMBER A6857 and B5529	
5. AUTHOR(S) Kevin G. DeWall Robert Steele, Jr.		6. TYPE OF REPORT Technical	
		7. PERIOD COVERED (Inclusive Dates)	
8. PERFORMING ORGANIZATION - NAME AND ADDRESS (If NRC, provide Division, Office or Region, U.S. Nuclear Regulatory Commission, and mailing address; if contractor, provide name and mailing address.) Idaho National Engineering Laboratory EG&G Idaho, Inc. P.O. Box 1625 Idaho Falls, ID 83415			
9. SPONSORING ORGANIZATION - NAME AND ADDRESS (If NRC, type "Same as above"; if contractor, provide NRC Division, Office or Region, U.S. Nuclear Regulatory Commission, and mailing address.) Division of Engineering and Division of Safety Issue Resolution Office of Nuclear Regulatory Research U.S. Nuclear Regulatory Commission Washington, DC 20555			
10. SUPPLEMENTARY NOTES			
11. ABSTRACT (200 words or less) This report presents the measured data and the analyses performed to date on the full-scale high-energy qualification and flow interruption gate valve testing to develop technical insights for the United States Nuclear Regulatory Commission (USNRC) effort regarding Generic Issue 87 (GI-87). The research was sponsored by the USNRC and conducted by researchers from the Idaho National Engineering Laboratory. We tested two 6-in., 900-lb class valve assemblies, which represent a significant percentage of the reactor water cleanup isolation valves installed in plant applications. These valves were modified before testing by adding a high temperature load cell in the valve stems, which allowed the direct measurement of valve stem thrust during both opening and closing valve cycles. Instrumentation installed in the flow loop and on the valve assemblies measured the important valve and system test responses. Additionally, during the test program, all of the currently popular motor operated valve diagnostic test systems monitored the performance of the valves. Initially the valves were subjected to the hydraulic and leakage qualification tests defined in ANSI B16.41 and then to flow interruption and reopening valve tests at boiling water reactor primary system water temperature and pressure conditions with downstream line break flows. For the two valves tested, results show that (a) the disc factor used in current industry motor operator sizing equations underpredicts actual valve thrust requirements at all high temperature loadings, and for one valve design the equations may require an additional term to account for nonlinear performance, (b) the thrusts required to close the valves were sensitive to the fluid temperature, and (c) the results of testing at lower pressures, temperatures, and flows cannot be extrapolated to design basis pressures, temperatures, and flows for valve designs that have not exhibited linear performance behavior during design basis prototypical testing.			
12. KEY WORDS/DESCRIPTORS (List words or phrases that will assist researchers in locating the report.) valve testing BWR reactor water cleanup Generic Issue 87 (GI-87)		13. AVAILABILITY STATEMENT Unlimited	
		14. SECURITY CLASSIFICATION (This Page) Unclassified (This Report) Unclassified	
		15. NUMBER OF PAGES	
		16. PRICE	

**UNITED STATES
NUCLEAR REGULATORY COMMISSION
WASHINGTON, D.C. 20555**

**OFFICIAL BUSINESS
PENALTY FOR PRIVATE USE, \$300**

**SPECIAL FOURTH-CLASS R.
POSTAGE & FEES PAID
USNRC
PERMIT No. G-67**