

NUREG/CR-5378  
EGG-2567

---

---

# Aging Data Analysis and Risk Assessment— Development and Demonstration Study

---

---

Prepared by  
A. J. Wolford, C. L. Atwood, W. S. Roesener

**Idaho National Engineering Laboratory  
EG&G Idaho, Inc.**

**Prepared for  
U.S. Nuclear Regulatory Commission**

## AVAILABILITY NOTICE

### Availability of Reference Materials Cited in NRC Publications

Most documents cited in NRC publications will be available from one of the following sources:

1. The NRC Public Document Room, 2120 L Street, NW., Lower Level, Washington, DC 20555
2. The Superintendent of Documents, U.S. Government Printing Office, P.O. Box 37082, Washington, DC 20013-7082
3. The National Technical Information Service, Springfield, VA 22161

Although the listing that follows represents the majority of documents cited in NRC publications, it is not intended to be exhaustive.

Referenced documents available for inspection and copying for a fee from the NRC Public Document Room include NRC correspondence and internal NRC memoranda; NRC bulletins, circulars, information notices, inspection and investigation notices; licensee event reports; vendor reports and correspondence; Commission papers; and applicant and licensee documents and correspondence.

The following documents in the NUREG series are available for purchase from the GPO Sales Program: formal NRC staff and contractor reports, NRC-sponsored conference proceedings, international agreement reports, grant publications, and NRC booklets and brochures. Also available are regulatory guides, NRC regulations in the *Code of Federal Regulations*, and *Nuclear Regulatory Commission Issuances*.

Documents available from the National Technical Information Service include NUREG-series reports and technical reports prepared by other Federal agencies and reports prepared by the Atomic Energy Commission, forerunner agency to the Nuclear Regulatory Commission.

Documents available from public and special technical libraries include all open literature items, such as books, journal articles, and transactions. *Federal Register* notices, Federal and State legislation, and congressional reports can usually be obtained from these libraries.

Documents such as theses, dissertations, foreign reports and translations, and non-NRC conference proceedings are available for purchase from the organization sponsoring the publication cited.

Single copies of NRC draft reports are available free, to the extent of supply, upon written request to the Office of Administration, Distribution and Mail Services Section, U.S. Nuclear Regulatory Commission, Washington, DC 20555.

Copies of industry codes and standards used in a substantive manner in the NRC regulatory process are maintained at the NRC Library, 7920 Norfolk Avenue, Bethesda, Maryland, for use by the public. Codes and standards are usually copyrighted and may be purchased from the originating organization or, if they are American National Standards, from the American National Standards Institute, 1430 Broadway, New York, NY 10018.

## DISCLAIMER NOTICE

This report was prepared as an account of work sponsored by an agency of the United States Government. Neither the United States Government nor any agency thereof, or any of their employees, makes any warranty, expressed or implied, or assumes any legal liability of responsibility for any third party's use, or the results of such use, of any information, apparatus, product or process disclosed in this report, or represents that its use by such third party would not infringe privately owned rights.

NUREG/CR-5378  
EGG-2567  
GF, R9, RM

---

---

# Aging Data Analysis and Risk Assessment— Development and Demonstration Study

---

---

Manuscript Completed: July 1992  
Date Published: August 1992

Prepared by  
A. J. Wolford\*, C. L. Atwood, W. S. Roesener

G. H. Weidenhamer, NRC Technical Monitor

Idaho National Engineering Laboratory  
Managed by the U.S. Department of Energy

EG&G Idaho, Inc.  
Idaho Falls, ID 83415

**Prepared for**  
**Division of Engineering**  
**Office of Nuclear Regulatory Research**  
**U.S. Nuclear Regulatory Commission**  
**Washington, DC 20555**  
**NRC FIN A6389**

---

\*DNV Technica  
355 East Campus View Blvd.  
Suite 710  
Columbus, OH 43235

## ABSTRACT

This work develops and demonstrates a probabilistic risk assessment (PRA) approach to assess the effect of aging and degradation of active components on plant risk. The work (a) develops a way to identify and quantify age-dependent failure rates of active components, and to incorporate them into PRA; (b) demonstrates these tools by applying them to a fluid-mechanical system, using the key elements of a NUREG-1150 PRA; and (c) presents them in a step-by-step approach, to be used for evaluating risk significance of aging phenomena in systems of interest.

Statistical tests are used for detecting increasing failure rates and for testing data-pooling assumptions and model adequacy. The component failure rates are assumed to change over time, with several forms used to model the age dependence—exponential, Weibull, and linear. Confidence intervals for the age-dependent failure rates are found and used to develop inputs to a PRA model in order to determine the plant core damage frequency. This approach was used with plant-specific data, obtained as maintenance work requests, for the auxiliary feedwater system of an older pressurized water reactor. It can be used for extrapolating present trends into the near future, and for supporting risk-based aging management decisions.



# CONTENTS

ABSTRACT .....	iii
EXECUTIVE SUMMARY .....	xiii
ACKNOWLEDGMENTS .....	xvii
1. INTRODUCTION .....	1-1
1.1 Purpose and Scope .....	1-1
1.2 Background .....	1-1
1.2.1 History .....	1-1
1.2.2 Motivation .....	1-1
1.3 Report Organization .....	1-2
2. PROJECT APPROACH .....	2-1
2.1 The Definition of Aging .....	2-1
2.2 Objectives for the Present Work .....	2-1
2.3 Assumptions .....	2-2
2.3.1 Assumptions Regarding the Data Employed in the Study .....	2-2
2.3.2 Assumptions Regarding the Analysis and Use of the Data .....	2-2
2.4 Limitations .....	2-3
2.5 Practical Inference: Is There Aging? .....	2-4
2.5.1 General Approach .....	2-4
2.5.2 Specific Application .....	2-5
2.6 Step-by-Step Approach for Aging Risk Analysis .....	2-6
2.6.1 Step 1. Develop Time Histories of Components .....	2-6
2.6.2 Step 2. Define Relevant Component Failure Modes .....	2-8
2.6.3 Step 3. Define Failure Criteria .....	2-8
2.6.4 Step 4. Apply the Failure Criteria to the Time Histories .....	2-8
2.6.5 Step 5. Construct Failure Timelines and Cumulative Failure Plots .....	2-8
2.6.6 Step 6. Perform Statistical Analysis .....	2-8
2.6.7 Step 7. Calculate $\lambda(t)$ .....	2-10
2.6.8 Step 8. Quantify the Age-Dependent Risk .....	2-10
3. PWR AUXILIARY FEEDWATER SYSTEM REVIEW .....	3-1
3.1 Design Function .....	3-1

3.2	Flowpath .....	3-1
3.3	Support Systems .....	3-3
3.4	Automatic Actuation and System Response .....	3-3
4.	COMPONENT FAILURE DATA .....	4-1
4.1	Component History .....	4-1
4.2	Definition of Relevant Component Failure Modes .....	4-3
4.3	Definition of Failure Criteria .....	4-3
4.4	Application of Failure Criteria to the Data .....	4-5
4.4.1	Broadly Defined Failure Data .....	4-5
4.4.2	Narrowly Defined Failure Data .....	4-11
4.5	Failure Timelines and Cumulative Failure Curves .....	4-15
5.	STATISTICAL METHODS FOR ANALYZING TIME-DEPENDENT FAILURES .....	5-1
5.1	Aging Models .....	5-1
5.2	Assumptions Regarding Failure Data .....	5-2
5.3	Inference Methods .....	5-3
5.3.1	Inference for $\beta$ .....	5-5
5.3.2	Investigating the Assumed Model Form .....	5-8
5.3.3	Inference for $\lambda_o$ , Given $\beta$ .....	5-10
5.3.4	Joint Inference for Both Parameters and for the Failure Rate .....	5-11
5.3.5	Joint Asymptotic Normality .....	5-11
6.	TIME-DEPENDENT FAILURE DATA ANALYSIS .....	6-1
6.1	Preparation of the Input .....	6-1
6.2	Statistical Screening Analysis .....	6-1
6.2.1	Common $\beta$ Test for All Components .....	6-1
6.2.2	Aging Test .....	6-9
6.2.3	Adequacy Check of the Assumed Form of the Aging Model .....	6-9
6.2.4	Common $\lambda_o$ Test for All Components Exhibiting Aging .....	6-16
6.2.5	MLE for $(\beta, \lambda_o)$ .....	6-16
6.2.6	Check of the Normal Approximation for Distribution of MLE .....	6-16
6.3	Calculation of $\lambda(t)$ as a Function of Time .....	6-18
6.4	Case Study Problem Specifications .....	6-18

7.	QUANTIFICATION OF TIME-DEPENDENT RISK .....	7-1
7.1	Time-Dependent Risk Analysis for AFW System .....	7-1
7.1.1	Use of Maximum Likelihood Results to Define Bayesian Distributions .....	7-1
7.1.2	Resulting Time-Dependent Component Failure Rate Inputs .....	7-1
7.1.3	PRA Adjustment to Allow Time-Dependent Risk Quantification .....	7-3
7.1.4	Results .....	7-3
7.1.5	Simultaneous Aging .....	7-5
7.2	Potential Applications .....	7-8
7.2.1	Extrapolation to Distant Future .....	7-8
7.2.2	Periodic Risk-Based Management .....	7-8
8.	CONCLUSIONS .....	8-1
9.	REFERENCES .....	9-1
	Appendix A—Estimating Hazard Functions for Repairable Components .....	A-1
	Appendix B—Tables of Maintenance Records .....	B-1

## LIST OF FIGURES

2-1.	Hypothetical 90% confidence intervals for $\beta$ .....	2-5
2-2.	An aging risk quantification approach .....	2-7
3-1.	Schematic diagram of the PWR auxiliary feedwater system .....	3-1
4-1.	Process used to develop component failure data .....	4-2
4-2.	Failure timelines to determine the occurrence times of steam binding of the AFW system pumps .....	4-12
4-3.	Failure to run timeline for steam- and motor-driven pumps .....	4-16
4-4.	Cumulative failure plot for steam-driven pumps, broadly defined failures to run .....	4-16
4-5.	Cumulative failure plot for steam-driven pumps, narrowly defined failures to run .....	4-17
4-6.	Cumulative failure plot for motor-driven pumps, broadly defined failures to run .....	4-17
4-7.	Failure to start timeline for steam- and motor-driven pumps .....	4-18
4-8.	Cumulative failure plot for motor-driven pumps, broadly defined failures to start .....	4-18
4-9.	Cumulative failure plot for motor-driven pumps, narrowly defined failures to start .....	4-19
4-10.	Plugging failure timeline for 3-in. MOVs (feed header isolation valves) .....	4-19
4-11.	Cumulative failure plot for 3-in. MOVs (feed header isolation valves), broadly defined plugging failures .....	4-20
4-12.	Cumulative failure plot for 3-in. MOVs (feed header isolation valves), narrowly defined plugging failures .....	4-20
4-13.	Failure to stay closed timeline for 6-in. MOVs (cross-connect valves) .....	4-21
4-14.	Cumulative failure plot for 6-in. MOVs (cross-connect valves), broadly defined failures to stay closed .....	4-21
4-15.	Cumulative failure plot for 6-in. MOVs (cross-connect valves), narrowly defined failures to stay closed .....	4-22
4-16.	Backflow failure timeline for pump discharge check valves .....	4-22
4-17.	Cumulative failure plot for pump discharge check valves, broadly defined backflow leakage failures .....	4-23
4-18.	Steam binding failure timeline for the steam- and motor-driven pumps .....	4-23
4-19.	Cumulative failure plot for the steam- and motor-driven pumps, broadly and narrowly defined steam binding failures .....	4-24

5-1.	Approach for statistical analysis of one data set .....	5-4
5-2.	Component comparisons for $\beta$ .....	5-6
5-3.	Component comparisons for $\beta$ , based on hypothetical data .....	5-6
5-4.	Q-Q plot .....	5-9
5-5.	Q-Q plot, based on hypothetical data .....	5-9
5-6.	Component comparisons for $\lambda_o$ .....	5-11
5-7.	90% confidence region for $(\beta, \lambda_o)$ , based on conditional likelihood .....	5-12
5-8.	90% confidence ellipse for $(\beta, \lambda_o)$ , based on joint asymptotic normality, overlaid on the region of Figure 5-7 .....	5-13
5-9.	90% confidence regions for $(\beta, \lambda_o)$ , based on Weibull failure rate model with $t_o$ at the middle of observation periods .....	5-13
5-10.	90% confidence regions for $(\beta, \lambda_o)$ , based on linear failure rate model with time measured from the component's installation .....	5-15
5-11.	90% confidence regions for $(\beta, \lambda_o)$ , based on linear failure rate model with time measured from the middle of observation periods .....	5-15
5-12.	MLE and 90% confidence band for $\lambda(t)$ , based on joint asymptotic normality for all three models .....	5-16
5-13.	MLEs and 90% confidence bands for $\lambda(t)$ , based on conservative calculations and on asymptotic normality for exponential model .....	5-16
5-14.	MLEs and 90% confidence bands for $\lambda(t)$ , based on conservative calculations and on asymptotic normality for Weibull model .....	5-17
5-15.	MLEs and 90% confidence bands for $\lambda(t)$ , based on conservative calculations and on asymptotic normality for linear model .....	5-17
6-1.	Process used to develop time-dependent failure rates .....	6-2
6-2.	Q-Q plot for pump discharge check valves, broadly defined back leakage failures, exponential model, based on failures before the data were reinterpreted .....	6-10
6-3.	Q-Q plot for pump discharge check valves, broadly defined back leakage failures, Weibull model, based on failures before the data were reinterpreted .....	6-10
6-4.	Q-Q plot for pump discharge check valves, broadly defined back leakage failures, linear model, based on failures before the data were reinterpreted .....	6-11
6-5.	Q-Q plot for 3-in. MOVs (header isolation valves), broadly defined plugging failures, exponential model .....	6-11

6-6.	Q-Q plot for 3-in. MOVs (header isolation valves), broadly defined plugging failures, Weibull model .....	6-12
6-7.	Q-Q plot for 3-in. MOVs (header isolation valves), broadly defined plugging failures, linear model .....	6-12
6-8.	Q-Q plot for 3-in. MOVs (header isolation valves), narrowly defined plugging failures, exponential model .....	6-13
6-9.	Q-Q plot for 3-in. MOVs (header isolation valves), narrowly defined plugging failures, Weibull model .....	6-13
6-10.	Q-Q plot for 3-in. MOVs (header isolation valves), narrowly defined plugging failures, linear model .....	6-14
6-11.	Q-Q plot for either broadly or narrowly defined pump steam binding failures, exponential model .....	6-14
6-12.	Q-Q plot for either broadly or narrowly defined pump steam binding failures, Weibull model .....	6-15
6-13.	Q-Q plot for either broadly or narrowly defined pump steam binding failures, linear model .....	6-15
6-14.	90% confidence regions for $(\beta, \lambda_o)$ for pump discharge check valves, broadly defined back leakage failures, exponential model, based on failures before the data were reinterpreted .....	6-19
6-15.	90% confidence regions for $(\beta, \lambda_o)$ for pump discharge check valves, broadly defined back leakage failures, Weibull model, based on failures before the data were reinterpreted .....	6-19
6-16.	90% confidence regions for $(\beta, \lambda_o)$ for 3-in. MOVs (header isolation valves), narrowly defined plugging failures, exponential model .....	6-20
6-17.	90% confidence regions for $(\beta, \lambda_o)$ for 3-in. MOVs (header isolation valves), narrowly defined plugging failures, Weibull model .....	6-20
6-18.	90% confidence regions for $(\beta, \lambda_o)$ for 3-in. MOVs (header isolation valves), narrowly defined plugging failures, linear model, time measured from component's installation .....	6-21
6-19.	90% confidence regions for $(\beta, \lambda_o)$ for 3-in. MOVs (header isolation valves), narrowly defined plugging failures, linear model, time measured from middle of observation periods .....	6-21
6-20.	90% confidence regions for $(\beta, \lambda_o)$ for pump steam binding, broadly or narrowly defined failures, exponential model .....	6-22
6-21.	90% confidence regions for $(\beta, \lambda_o)$ for pump steam binding, broadly or narrowly defined failures, Weibull model .....	6-22

7-1.	Calculated mean CDF and 90% interval after the data were reevaluated .....	7-5
7-2.	Calculated mean CDF and 90% interval before the data were reevaluated .....	7-7

## LIST OF TABLES

ES-1.	Example decision matrix .....	xv
3-1.	PWR AFW system component status and support system dependency summary .....	3-2
4-1.	Distribution of raw maintenance events for the AFW system according to component type .....	4-3
4-2.	AFW system component failure modes, descriptions, and relevant component numbers, corresponding to Figure 3-1 .....	4-4
4-3.	Distribution of broadly defined failure occurrences according to component type .....	4-6
4-4.	Distribution of broadly defined failure occurrences according to failure mode .....	4-6
4-5.	Sample of maintenance records for the AFW system steam-driven pumps .....	4-7
4-6.	Sample of maintenance records broadly classified as failures for the AFW system steam-driven pumps .....	4-8
4-7.	Sample of maintenance records broadly classified as failures for the AFW system steam-driven pumps, rewritten format .....	4-9
4-8.	Sample of maintenance records narrowly classified as failures for the AFW system steam-driven pumps, rewritten format .....	4-13
4-9.	Distribution of narrowly defined failure occurrences according to component type .....	4-14
4-10.	Distribution of narrowly defined failure occurrences according to failure mode .....	4-14
6-1.	Formatted data used for the analysis of broadly defined failures .....	6-3
6-2.	Formatted data used for the analysis of narrowly defined failures .....	6-5
6-3.	Results of statistical analysis of the broadly defined failures .....	6-7
6-4.	Results of statistical analysis of the narrowly defined failures .....	6-8
6-5.	MLEs for $\beta$ and $\lambda_0$ by aging model and failure definition .....	6-17
6-6.	MLEs of $\lambda(t)$ and associated confidence intervals by failure mode definition for the exponential model .....	6-23
6-7.	MLEs of $\lambda(t)$ and associated confidence intervals by failure mode definition for the Weibull model .....	6-24

6-8.	MLEs of $\lambda(t)$ by failure mode definition for the linear model .....	6-25
6-9.	Failure sets analyzed as a function of failure definition and significance level .....	6-26
7-1.	Mean values of $\lambda(t)$ and associated error factor by failure definition and failure model ....	7-2
7-2.	Mean values of CDF and associated uncertainties quantified after reinterpretation of raw data .....	7-4
7-3.	Mean values of CDF and associated uncertainties quantified before reinterpretation of raw data .....	7-6
8-1.	Example decision matrix .....	8-2



## EXECUTIVE SUMMARY

The present work develops and demonstrates a probabilistic risk assessment (PRA) approach to assess the effect of aging and degradation of active components on plant risk. The work supports the Nuclear Plant Aging Research Program sponsored by the U.S. Nuclear Regulatory Commission (USNRC). The work consists of three tasks:

- Develop a way to identify and quantify age-dependent failure rates of active components, and to incorporate them into PRA.
- Demonstrate this approach by applying it, with plant-specific data, to a fluid-mechanical system, using the key elements of a NUREG-1150<sup>a</sup> PRA.
- Present it as a step-by-step approach, so that others can use it for evaluating risk significance of aging phenomena in systems of interest.

The approach was applied to analyze maintenance data from the auxiliary feedwater (AFW) system of an older pressurized water reactor (PWR). Only the AFW system was assumed to be aging. The age-dependent failure rates were then input to the plant's NUREG-1150 PRA at various assumed plant ages to show the effect of aging on core damage frequency.

A number of assumptions were made to accomplish this work. For the data, it was assumed that the component maintenance records obtained for use in this study were complete and the "return-to-service-date" for corrective maintenance performed on components determined to have failed was an acceptable surrogate for the date of failure. For the data analysis and system modeling it was assumed that the failures of a component follow a nonhomogeneous (time-dependent) Poisson process, with time-dependent failure rate  $\lambda(t)$ . The Poisson assumption implies that failures are

independent. The general form assumed for  $\lambda(t)$  involved a parameter  $\beta$  that governs the rate of aging by means of a function  $h$  and a constant multiplier  $\lambda_o$ , all related by

$$\lambda(t) = \lambda_o h(t; \beta)$$

The three specific models considered in this report are

$$\lambda(t) = \lambda_o e^{\beta t} \quad (\text{exponential failure rate})$$

$$\lambda(t) = \lambda_o (t/t_o)^\beta \quad (\text{Weibull failure rate})$$

$$\lambda(t) = \lambda_o (1 + \beta t) \quad (\text{linear failure rate}).$$

For the Weibull model,  $t_o$  is an arbitrary normalizing time. Each assumed model was routinely checked in the data analyses with the following results. There was some clustering of the failure times; during an intermediate analysis, but not after the final analysis, there was enough clustering in one data set to cast strong doubt on the Poisson assumption. The choice of an exponential, Weibull, or linear form for  $\lambda(t)$  never had much effect on the fit of the model to the data.

It was further assumed that replaced components in the data record could be considered as good as new, while repaired components could be considered as good as old; and that the components in place at the start of the data period were installed when the plant began commercial operation, approximately four years before the start of the data period. For risk modeling, it was assumed that an increasing failure rate reflected aging, and so could be extrapolated into the near future; and the published NUREG-1150 PRA was complete as modeled and could adequately model all systems other than the AFW system, with only minor modifications needed for the AFW system to account for aging.

The approach used statistical tests to detect increasing failure rates and to test data-pooling assumptions and model adequacy. Point estimates and confidence intervals were found for the model parameters  $\beta$  and  $\lambda_o$ . These were

---

a. USNRC, *Severe Accident Risk Assessment for Five U.S. Nuclear Power Plants*, NUREG-1150, Draft 2, 1989.

translated into estimates for the age-dependent failure rates. In any short time period, such as one year, each failure rate  $\lambda_i$  was treated as a constant and used to develop inputs to a PRA model, yielding the plant core damage frequency (CDF).

Based on the statistical data analyses, only selected components were modeled as aging in the PRA. To identify these components, two criteria were used. Components were modeled as aging if a test showed statistically significant aging (a) at the 5% significance level (strong evidence of aging) or (b) at the 40% significance level (very weak evidence of aging). Both significance levels were used because there is no sharp dividing line between aging and non-aging.

To help account for the subjectivity in interpreting the maintenance records, two definitions of failure were used. A broadly defined failure was one where the maintenance record might possibly have described a safety-related failure, whereas a narrowly defined failure was one where the maintenance record certainly described a failure. The narrowly defined failures were a subset of the broadly defined failures. The exact criteria for each definition are clearly stated in this work to allow for repeatability of the analysis.

The final result of applying the above approach was that two components showed some evidence of increasing failure rate. Extrapolation of these failure rates into the near future resulted in negligible changes in CDF from those calculated in the NUREG-1150 PRA.

Two conclusions of importance are as follows:

- A step-by-step approach was developed and demonstrated that provides a workable way to estimate present and near-term future risk based on the modeling assumptions.
- Three aging models were considered: the exponential, Weibull, and linear failure rate models. With the data used, they produced very similar results for the data observation period and for extrapolations into the near

future. However, the exponential model clearly behaved best for quantifying uncertainties, and the linear model clearly behaved worst, being in some ways unusable.

Several difficulties were noted in applying the approach. First, data from 10 years of AFW system operation at two units provided too little information to precisely estimate the degree of aging for many failure modes, although this data set was comparatively large for such a plant-specific sample of failure events. Second, classification of failure data from old records was difficult, and necessitated the use of broad and narrow definitions of failure. Third, failures tended to cluster in time. Finally, the maintenance and operational environment may have changed at times in the plant's history. Some of these difficulties could be addressed by discussions with people directly familiar with the plant equipment, practices, and history.

We also make the following observations concerning the possible application of the methodology:

- Extrapolation of observed trends to the distant future would require more explicit incorporation of maintenance and replacement policies. They are treated implicitly here, as part of the environment for the observed past failure events. Therefore, the approach of this report should not be used for distant extrapolation.
- Periodic use of the approach at a plant is suggested to help prioritize surveillance, maintenance, and engineering analysis efforts according to risk.

For managers who must make decisions based on three models, two definitions of failure, and two significance levels, we, the authors of this report, offer the following suggestions. Use the exponential failure model. When aging of a component results in a significant increase in CDF, use a table similar to the following example.

**Table ES-1.** Example decision matrix.

	Broadly defined failures	Narrowly defined failures
No-aging assumption rejected at significance level of 0.40	Awareness. Inform operations and maintenance staffs of potential problem. Reanalyze if failures persist.	Strong interest. Inform operations and maintenance staffs of potential problem. Reanalyze after short period of time.
No-aging assumption rejected at significance level of 0.05	Strong interest. Investigate immediately to determine which maintenance records describe actual failures of concern.	Very strong interest. Investigate immediately and determine what mitigating action should be taken.

## ACKNOWLEDGMENTS

The authors of this report acknowledge Jitendra P. Vora, USNRC Nuclear Plant Aging Research (NPAR) Program Coordinator, and Gerald H. Weidenhamer, USNRC NPAR Project Manager, for their management of this work.

Special thanks go to Robert C. Bertucio of NUS Corporation for clarifying questions about the PRA quickly and thoroughly, and to the director of Nuclear Operations and Maintenance Support at the power station for providing additional information about some of the events reported in the maintenance records. Thanks are also due to William E. Vesely, SAIC, for oral comments and for initially identifying Laplace's test, which is a rudiment of the work presented in this report. Thanks also go to John Boccio of Brookhaven National Laboratory for sharing the raw maintenance data that were collected as a part of the USNRC's Performance Indicator Program.

Thanks are due to many additional colleagues at the INEL: Lee C. Cadwallader, Dennis A. Conley, Babette M. Meale, Ollie B. Meeky, and R. Niall M. Hunt for assisting with data processing and interpretation; Tammy Swantz and Carol L. Olaveson for updating the PRA models used in the IRRAS program; Geraldine S. Reilly for preparing many of the technical illustrations; H. Lowell Magleby for advice and review; and Julie M. Steffes and Karen MacDonald for guiding the report through the many steps of publication.

Written comments on Revision 1 of the draft report were received from Dale Rasmuson and Les Lancaster of the USNRC, from Elizabeth Kelly and Richard Beckman of Los Alamos National Laboratory, and from the Director of Nuclear Operations and Maintenance Support at the power station. Written comments on Revision 2 were received from William E. Vesely of SAIC. We carefully considered each comment and made use of nearly all of them, either by incorporating the suggestions into the present version of the report or by clarifying the earlier text. We are grateful for all the comments.

# Aging Data Analysis and Risk Assessment—Development and Demonstration Study

## 1. INTRODUCTION

### 1.1 Purpose and Scope

The present work was planned to develop and demonstrate a probabilistic risk assessment (PRA) approach to assess the effect of aging and degradation of active components on plant risk. This goal consisted of three tasks:

- Develop a way to identify and quantify age-dependent failure rates of active components, and to incorporate them into PRA.
- Demonstrate this approach by applying it, with plant-specific data, to a fluid-mechanical system, using the key elements of a NUREG-1150 PRA (USNRC 1989).
- Present it as a step-by-step approach, so that others can use it to evaluate the risk significance of aging phenomena in systems of interest.

This study was restricted to active components. Parallel work on passive components is described by Phillips et al. (1990).

### 1.2 Background

**1.2.1 History.** The oldest licensed commercial nuclear power station has been operating for about 30 years. As a part of its responsibilities to protect the health and safety of the public, the United States Nuclear Regulatory Commission (USNRC) is concerned about the aging of major components, structures, and safety systems in nuclear power plants. Therefore, the USNRC has initiated the Nuclear Plant Aging Research (NPAR) Program (USNRC 1987) to develop technical bases for the systematic assessment of the effects of aging on plant safety and public risk.

Many hardware- and material-oriented research programs have been implemented in the NPAR program to gain an understanding of aging and degradation phenomena in safety-significant nuclear power plant equipment. This understanding will contribute to the identification and resolution of aging-related technical issues, and to recommendations on how to identify, detect, and control (manage) the effects of equipment aging. Aging management must use appropriate tools and techniques to ensure that components and systems are identified according to their risk significance, and that they are maintained at an acceptable level of reliability over the operating life of the plant.

One specific task of the NPAR program, Risk Evaluation of Aging Phenomena, was chartered to develop and extend PRA techniques to evaluate the impacts of equipment aging and degradation on overall plant risk indices, such as safety system unavailability and core damage frequency (CDF). The present work was performed as part of this task.

**1.2.2 Motivation.** Risk assessment is a key element of the NPAR program. Aging risk assessment is envisioned for the following purposes:

- Identify risk-significant components and systems in which aging is a concern
- Provide assurance that ongoing aging management programs maintain an acceptable level of plant safety
- Provide input to set schedules for activities that control the effects of aging, such as testing, surveillance, and replacement

- Examine the risk significance of plant-specific design features/modifications and select effective ways to reduce plant risk
- Prioritize resources for hardware-oriented aging research (Levy et al. 1988)
- Perform value-impact regulatory analysis.

A close look at current state-of-the-art PRA technology reveals that incorporation of time-dependence requires (a) development of a way to treat time-dependence in PRA inputs, (b) examination of the standard PRA approaches for implicit non-aging assumptions, and (c) documentation of PRA approaches for aging. The goal of the Risk Evaluation of Aging Phenomena task is to develop ways to incorporate the effects of aging into PRA, thereby supporting the development of regulatory criteria and strategies and addressing the technical issues related to plant aging.

### 1.3 Report Organization

Section 1 states the purpose and scope of this report. It also gives a brief background and motivation for this study.

Section 2 gives the overall approach taken in this report. It presents definitions, specific objectives, assumptions, and limitations. It explains

points to consider when facing the question "Is there aging?" Finally, it gives a summary of the step-by-step approach developed in this work.

Section 3 describes the pressurized water reactor (PWR) auxiliary feedwater (AFW) system used in demonstrating the approach.

Section 4 describes how the data from the AFW system were interpreted for the demonstration.

Section 5 presents a conceptual view of the statistical elements of the data analysis, with the technical details relegated to Appendix A.

Section 6, presents the application of this analysis approach to the AFW data. The result is a set of estimated age-dependent failure rates for certain components in the AFW system.

Section 7 uses these age-dependent failure rates to modify the NUREG-1150 PRA and then to calculate risk as a function of time.

Section 8 summarizes the main results of the report.

Section 9 lists the references cited.

Finally, Appendix A contains technical details of the statistical methods, and Appendix B contains tables of the AFW maintenance records.

## 2. PROJECT APPROACH

### 2.1 The Definition of Aging

The NPAR definition of aging used in this work is "...the cumulative degradation which occurs with the passage of time in a component, system, or structure [that] can, if unmitigated, lead to loss of function and an impairment of safety." (USNRC 1987) It is important to consider the details of this definition to understand, in context, the assumptions made in the development and application of the aging assessment approach.

First, consider the meaning of "passage of time." Often this is interpreted as simply a calendar process. However, the amount of degradation that occurs within a given period of time depends on the degrading conditions present. The degrading conditions are created by the operational environment, which includes the effects of operational procedures, policies, and maintenance. Changes in the operational patterns affect the degrading environment. In this report we assumed that degrading conditions remained constant, so that calendar time could be used as a surrogate for time at degrading conditions.

Next, consider "cumulative degradation." In some cases degradation occurs so slowly under the degrading conditions present that it can not be observed. Practically speaking, the aging is negligible. If the effects of degradation can be observed, an equation describing the amount of degradation as a function of time is necessary in order to quantify and predict the aging.

Next, consider "mitigation." The amount of degradation and the rate at which degradation accumulates can be changed (mitigated) through the performance of maintenance activities. If a maintenance activity results in complete renewal/replacement of all the degraded parts of a component, then that component may be considered as good as new, that is, unaged. If the maintenance activity results in the renewal/replacement of only a subset of the degraded parts, the component may be considered better than old but not as good as new; that is, the functional form of further

degradation may well be different from that occurring before the maintenance because of the complicated interaction of new and degraded parts. If the maintenance activity results in the return of the component to a condition nearly equivalent to that before the maintenance was performed (for example, the repair/replacement of a single part) then the component may be considered as good as old. Finally, the component may be better than new if a part or parts were replaced with better than original equipment, or worse than old as a result of faulty parts or improper performance of the maintenance. The quantitative modeling of this report assumes that replacement makes a component as good as new, while repair makes it as good as old. Mitigating surveillance and maintenance programs are considered as part of the normal conditions at the plant and are not modeled explicitly.

Finally, consider degradation that can "lead to a loss of function and an impairment of safety." The important detail to understand here is that not all degradation that results from the passage of time contributes to the failure of a safety-specific function. For example, the leakage of water from a secondary system valve may well be inconvenient, but may not affect the functional safety of the valve. On the other hand, the leakage of primary coolant from a reactor coolant system valve does represent safety-related functional degradation, which needs to be quantified to describe aging. For this report, maintenance records were screened and only safety-related events were used.

### 2.2 Objectives for the Present Work

In order to meet the purposes listed in Section 1.1, the objectives of the present work are to develop and document an understandable step-by-step approach for accomplishing the following analysis:

- Identify statistically significant and non-significant increasing failure rates for components in the AFW system of an older

## Project Approach

PWR nuclear power station using available plant-specific component history information (standard plant maintenance records) and simple trend tests.

- Quantify the failure rate for those components found to exhibit statistically significant trends.
- Incorporate the failure estimates and uncertainties into an appropriate PRA model and compute the implied age-dependent plant risk index (CDF), uncertainty, and important contributors (sequences, component faults). A NUREG-1150 PRA was used for this computation.

## 2.3 Assumptions

This section lists the assumptions used to make inferences for this work and distinguishes these nonstandard assumptions from the normal tenets of nuclear plant PRA. Not one of these assumptions is believed to be perfectly true. They all simplify reality somewhat in order to build a mathematical model of the plant and thereby allow the risk to be quantified. With a more intimate knowledge of the plant history or with more detailed repair records, it might be possible to modify some of the assumptions. When refining the assumptions, however, one must take care not to build a model with so many parameters that they cannot be estimated well with the available data.

The assumptions are listed here to make explicit the scope of applicability of the approach. If in a different setting some of the assumptions are known to be far from correct, then the approach given in this report must be modified or applied separately to distinct portions of the data for which the assumptions are approximately true.

**2.3.1 Assumptions Regarding the Data Employed in the Study.** Section 4 provides a detailed description of the steps involved in developing component history data. The following is a concise list of the assumptions that directly involve the data.

1. The component maintenance records obtained for use in this study were complete in the sense that all corrective repairs and replacements were included (for the time spanned by the records).
2. The "return-to-service-date" for corrective maintenance performed on components determined to have failed was an acceptable surrogate for the date of failure.
3. Unit-specific data for two sister units reflected similar operating environments and maintenance and, therefore, could be pooled to increase the sample size. This assumption was always tested formally and always appeared acceptable.

These assumptions are also commonly made for an ordinary PRA. The only difference is that the failure date in Assumption 2 is not needed when estimating a constant failure rate.

**2.3.2 Assumptions Regarding the Analysis and Use of the Data.** Details of the statistical methods employed are described in Section 5 and Appendix A. Assumptions regarding data analysis and system modeling are as follows:

1. The failures of a component follow a non-homogeneous (time-dependent) Poisson process, with time-dependent failure rate,  $\lambda(t)$ . The Poisson assumption implies that failures are independent. The general form assumed for  $\lambda(t)$  involves a parameter  $\beta$  that governs the rate of aging by means of a function  $h$  and a constant multiplier  $\lambda_o$ , all related by

$$\lambda(t) = \lambda_o h(t; \beta).$$

The three specific models considered in this report are

$$\lambda(t) = \lambda_o e^{\beta t} \quad (\text{exponential failure rate})$$

$$\lambda(t) = \lambda_o (t/t_o)^\beta \quad (\text{Weibull failure rate})$$

$$\lambda(t) = \lambda_o (1 + \beta t) \quad (\text{linear failure rate})$$



For the Weibull model,  $t_o$  is an arbitrary normalizing time.

2. The components' environments (ambient conditions, maintenance and operation practices, and any degrading conditions) were constant throughout the data period. As a consequence it follows that
  - Increasing failure rate reflects aging, and therefore the increase can be extrapolated into the near future. Simple extrapolation into the far future is unjustified because it is likely that badly aged components will be discovered and replaced eventually.
  - Calendar time is an acceptable surrogate for the time at degrading conditions.
3. Replaced components were considered as good as new, while repaired components were considered as good as old.
4. The components in place at the start of the data period were installed when the plant began commercial operation. This means that no components were replaced during the first 4.5 (approximately) years; note that in 10 years of data records, very few components were replaced.
5. The published NUREG-1150 PRA was complete as modeled and could adequately model all systems other than the AFW system. Minor modifications to the AFW system fault trees are specifically identified in Section 7.1.3.

Assumptions 1 through 4 go beyond those of an ordinary PRA, as follows. Assumption 1: Normally, the failures are assumed to follow a Poisson process with a constant failure rate. Assumption 2: The assumption of a constant environment is implicit in the assumption of a constant failure rate. Assumption 3: The concepts good-as-new and good-as-old are irrelevant when the failure rate is constant. Assumption 4: The age of a

component at the start of the data period is irrelevant when the failure rate is assumed not to depend on the component's age.

A non-constant environment may affect the calculated failure rate. For example, if maintenance practices are evolving and improving, the calculated failure rate will gradually decrease. If the environment fluctuates, but has no long-term trend, then failures may be more frequent when the operating environment is less than optimal. However, no long-term upward or downward trend will result in the calculated failure rate.

Assumption 1 was routinely checked in the data analyses. There was some clustering of the failure times. During an intermediate analysis, but not after final analysis, there was enough clustering in one data set to cast strong doubt on the Poisson assumption. The choice of an exponential, Weibull, or linear form for  $\lambda(t)$  had little effect on the fit of the model to the data. The good-as-new portion of Assumption 3 was checked through a test for equality of the  $\lambda_o$  values. We did not have a technique for checking the good-as-old portion of Assumption 3, and we did not have enough information to check Assumptions 2, 4, and 5.

## 2.4 Limitations

It goes without saying that the approach of this report is not the only possible one. For example, Bayesian approaches could be used, such as in Bier et al. (1990). Other forms for  $\lambda(t)$  could also be developed, besides the three used here. An approach may be developed for allowing  $\lambda(t)$  to vary continuously in a PRA; this would avoid the stepwise approximation used here. The indistinct border between aging and nonaging could be handled in various ways. Although these other approaches might yield somewhat different results, valid approaches should not yield substantially different conclusions from the same data.

A related issue is extrapolation. The three models for  $\lambda(t)$  considered here (exponential, Weibull, and linear) could not be distinguished by how well they fit the data used in this report. However, they would yield very different results at times far in the future. This means that none of the models can be

## Project Approach

used for reliable distant extrapolation of this data set. This is no surprise to experienced data analysts, who recognize the pitfalls of ever extrapolating a model far beyond the observed data; for example see Hahn and Meeker (1982).

There is an additional issue affecting extrapolation in the present context. The analysis approach of this report treats maintenance policies as part of a component's operating environment, assumed to be constant. The failure data were generated within this environment. The maintenance policies would very probably change, however, if failures started to occur much more frequently. Therefore, for extrapolation do not simply ask "Which of the assumed forms of  $\lambda(t)$  is correct?" In reality, none of them can be extrapolated beyond the point where maintenance policies would change. Any distant extrapolation using only the approach of this report must be regarded at best as a diagnostic tool, not as a realistic prediction. This report does not show any extrapolation more than three years beyond the last year of data.

A valid distant extrapolation, using existing data, would require the following as a minimum: thorough knowledge of the past maintenance policies and the way they affected the failures of record; explicit incorporation in the model of the past policies and hypothesized future policies; and interpretation of the failure data so that what was observed under the past maintenance policies can be extrapolated to occurrences when the future policies are in place. This would be a formidable task.

## 2.5 Practical Inference: Is There Aging?

**2.5.1 General Approach.** Sometimes we would like to decide whether aging is present or not. When the question is phrased in this way, data analysts often cannot give a conclusive answer. This apparent indecisiveness follows not from some perversity of statistical methodology, but from the poor phrasing of the question. There is no clear dividing line between aging and non-aging. Without enormous amounts of data, extremely slow aging cannot be distinguished from no aging,

and indeed a practical decision-maker probably does not wish to make a distinction between extremely slow aging and no aging. It is, therefore, more informative to replace the yes-or-no question, "Is there aging?" by a quantitative question, "How much aging is there?"

Aging is modeled in this report, and the amount of aging is measured by a parameter  $\beta$ . In each of the three models assumed in this report,  $\beta = 0$  means that the failure rate is constant, that is, there is no aging. An increasing failure rate, interpreted as aging of the component, is modeled by  $\beta > 0$ , and a decreasing failure rate by  $\beta < 0$ .

The yes-or-no question "Is there aging?" corresponds to a statistical test of the hypothesis  $\beta = 0$ . The quantitative question "How much aging is there?" corresponds to a statistical confidence interval for  $\beta$ . In general, a confidence interval provides more information than a hypothesis test. The two are related in the following simple way. Suppose that data have been collected. For any number  $\beta_0$ , we can test the hypothesis  $\beta = \beta_0$ . A confidence interval consists of all the values  $\beta_0$  that would be accepted by the test.

For example, suppose that  $(1E-5, 6E-5)$  is a 90% confidence interval for  $\beta$ . This says that we are 95% confident that  $\beta > 1E-5$  and 95% confident that  $\beta < 6E-5$ , and therefore 90% confident that the interval contains  $\beta$ . The value  $\beta = 1E-5$  is rejected in favor of a larger  $\beta$  at the 5% significance level. (A significance level is 1 minus a confidence level, so 5% significance and 95% confidence are equivalent.) The value  $\beta = 0$  is also rejected at a significance level less than 5% because 0 is less than  $1E-5$ . In fact, every value of  $\beta$  that is less than  $1E-5$  would be rejected at a significance level less than 5%. Therefore, the confidence interval shows not only whether a particular hypothesized  $\beta$  is rejected, but also all the values that are rejected at a given significance level.

Figure 2-1 shows five hypothetical 90% confidence intervals from imaginary data sets. The

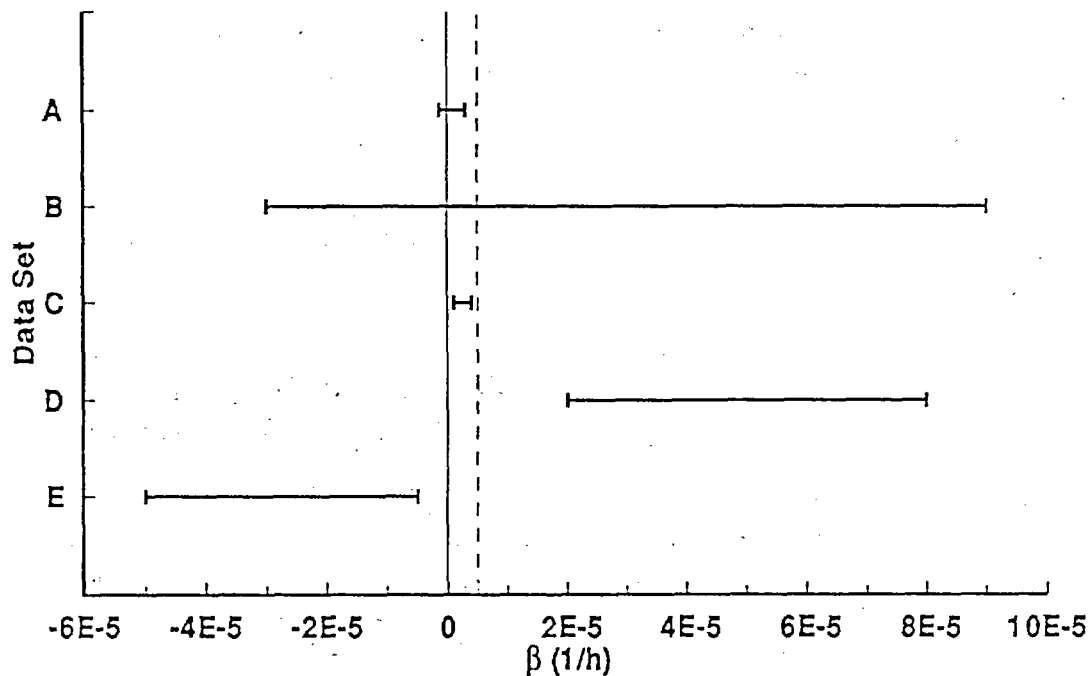


Figure 2-1. Hypothetical 90% confidence intervals for  $\beta$ .

solid vertical line marks  $\beta = 0$ , indicating no aging. The dashed vertical line at  $\beta = 0.5E-5$  marks a level that has been judged to be practically negligible. (This number is an illustration only, not a claim that any particular value of  $\beta$  is negligible in reality.) The wide confidence intervals presumably come from data sets with few observed failures, while the short intervals come from data sets with many observed failures.

The confidence intervals for A and B both include the value 0. Therefore, in both cases a test would not reject the hypothesis  $\beta = 0$  at the 5% level, and the analyst could report that there is no statistically significant evidence of aging. The confidence intervals reveal much more, however. Interval A lies to the left of  $0.5E-5$ , so we are 95% confident that any aging is negligible. Interval B, on the other hand, is quite wide. Failure to find aging really indicates failure to reach any firm conclusion at all because of insufficient data.

The intervals C and D both lie to the right of zero. Therefore, both cases show statistically significant evidence of aging at the 5% level. In case C, however, the aging is positive, but small

enough to be negligible, while in case D the aging is clearly not negligible.

Interval E lies entirely to the left of zero. Therefore, this interval represents the only data set for which we are 95% confident that there is no aging.

In this example the five confidence intervals provide much more information than five yes-or-no answers to the question, "Is there statistically significant evidence of aging?" As a result, in this report confidence intervals are generally preferred over tests as a way of reporting conclusions. Tests are used only as a preliminary screening device. A test result should be thought of as shorthand for part of the information contained in a confidence interval.

**2.5.2 Specific Application.** The data for this report differ from the preceding hypothetical example in two ways. First, no negligible value for  $\beta$  has been established. Second, because the data come from only 10 years at one system in one plant, they do not yield the extremely short intervals exemplified by A and C. The interval B is most typical of the intervals produced from the small numbers of failures actually observed.

## Project Approach

Suppose that interval B corresponded to data from real components. How should those components be treated in a risk quantification? Should they be treated as aging or not? In this study, two options were followed.

- Unless the data show statistically significant aging at the 5% level, do not change the PRA. Therefore, the components corresponding to interval B would be treated as non-aging, with a constant failure rate taken from the PRA.
- Follow the same approach, but use the 40% significance level instead of 5%. This is equivalent to treating the component as aging only if the 20% confidence interval for  $\beta$  lies to the right of zero. A 20% interval is much shorter than a 90% interval, so under this option the components corresponding to interval B might be treated as aging.

The first option makes minimal changes to the PRA, only changes that are forced by statistically significant evidence of aging. The second option makes more changes. Set D would be treated as aging under either option, while set B could be considered aging only under the second. In principle, the second option introduces wider uncertainty bands in the final results, for two reasons. First, the model for plant risk involves more parameters, the  $\beta$ s, and therefore more sources of uncertainty. Second, components that appear to be aging at the 40% significance level but not at the 5% level often have large uncertainties in  $\beta$ , resulting in substantial contributions to the uncertainty in the calculated plant risk.

No data sets in this report give intervals resembling set E, which has a decreasing failure rate that is statistically significant at the 5% level. However, some cases of decreasing failure rates are significant at the 40% level. These are modeled not as decreasing, but as constant failure rates, just as in the PRA. Therefore, the second option biases the approach toward more aging than is actually present, as follows. Consider a set

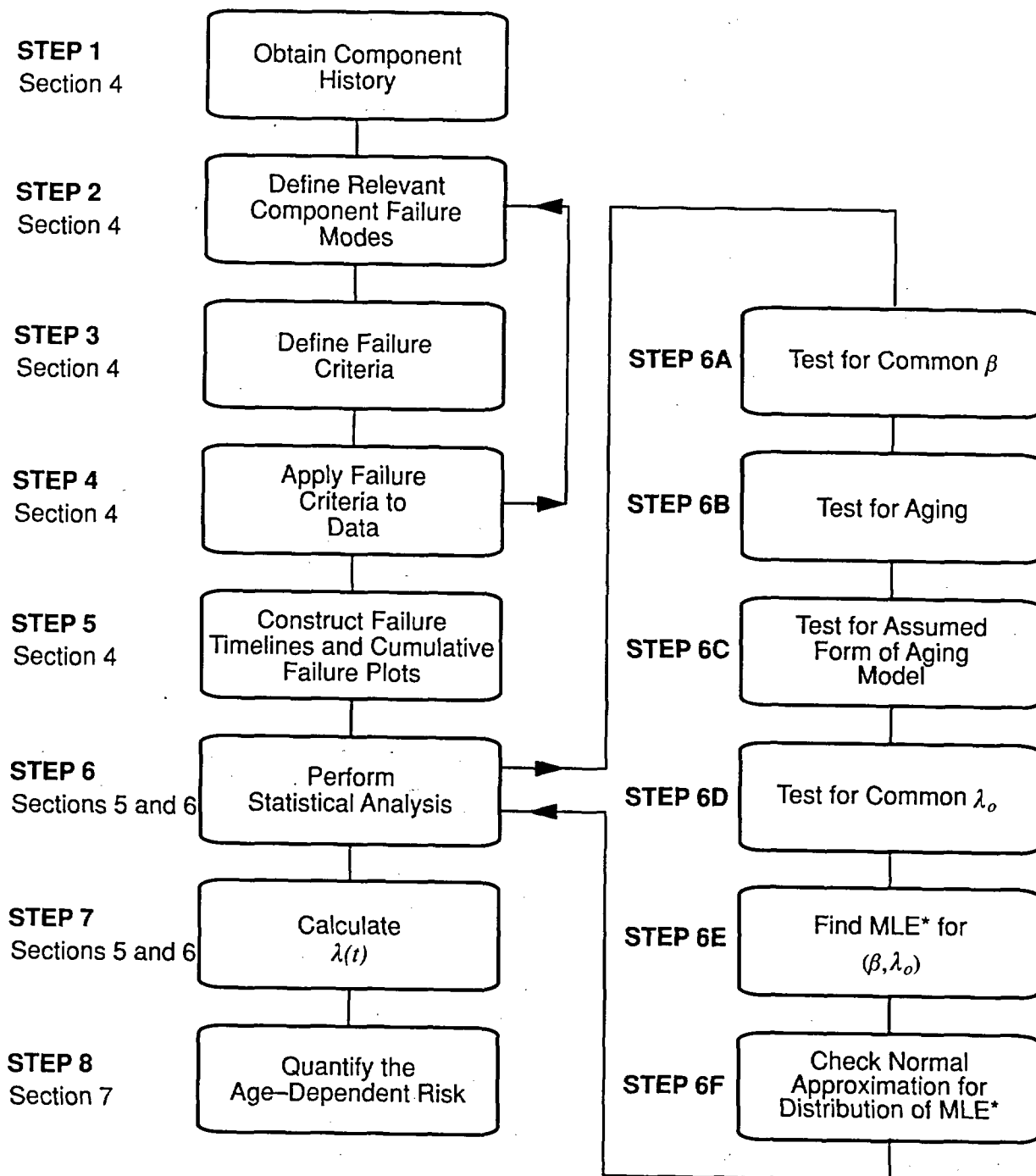
of components that actually have a constant failure rate. There is a 40% chance that they will appear to be aging at the 40% significance level because of the random nature of the failures. If this occurs, they will be modeled as having an increasing failure rate. On the other hand, there is no chance that they will be modeled as having a decreasing failure rate because we choose not to do this.

## 2.6 Step-by-Step Approach for Aging Risk Analysis

Sections 4 through 7 follow a step-by-step approach for aging risk analysis. These steps are summarized in the following sections and shown in the flow diagram of Figure 2-2. The first five steps are explained and shown in more detail in Section 4.1. Steps 6 and 7 are explained and shown in more detail in Sections 5 and 6.

**2.6.1 Step 1. Develop Time Histories of Components.** The first step is to obtain the information required to develop time histories for the systems/components to be analyzed. Possible sources of information include maintenance records, material histories, operating records, and plant process computer data. Comparison of data from numerous sources will aid in the development of the most reliable histories. Although very little attention was given to this step while developing this aging risk assessment approach, it should not be construed that the development is trivial or unimportant. On the contrary, the time histories are the backbone of the analysis and may be extremely difficult to develop. Poorly developed time histories can result in either the false identification of aging where none is occurring or the false conclusion that aging is not occurring when it actually is. These two kinds of errors result in over- and under-estimation of future risk, respectively. An overview for data base development that could be applied to the development of component time histories was prepared by the Yankee Atomic Electric Company (Ghahramani 1989).

# MODEL



\* MLE = maximum likelihood estimate

LF91 0310

Figure 2-2. An aging risk quantification approach.

Once the raw time-history data are collected, they should be categorized and stored in some convenient computer format to allow for easier reduction and analysis. Section 4 of this report details the process of data development followed for this demonstration, from raw maintenance records to failure occurrence timelines.

**2.6.2 Step 2. Define Relevant Component Failure Modes.** The second step is the identification of the failure modes associated with components or systems being analyzed that will contribute to an increase in plant risk. These failure modes should be obtained from a plant-specific PRA. Failure modes removed from consideration in a PRA at an early stage should not be ignored because of the low contribution to risk (e.g., removed from the cut sets by truncation). These failure modes may become more important, potentially even controlling, as a result of the increase in their frequency with the passage of time. The specific component boundaries used in the PRA for establishing failure modes should also be noted. These boundaries are necessary to correctly relate failure history to failure mode. Section 4.2 contains the definitions of the failure modes used in this demonstration study.

**2.6.3 Step 3. Define Failure Criteria.** The determination of whether a particular record from the information gathered in Step 1 describes the occurrence of one of the failure modes listed in Step 2 is often subjective. The information in the records was not designed for the development of failure tracking; therefore, the information is imprecise as to the exact condition of the component. In order to bracket this subjectivity and to facilitate a more repeatable development of failure time histories, two sets of failure criteria for each failure mode are developed in this report.

The first set of criteria is developed for a "broad" definition of failure. The criteria consist of a list of those conditions considered to possibly describe a failure, but which may only describe a problem that was fixed before it was actually necessary to remove the component from service.

The second set of criteria is developed for a "narrow" definition of failure. The criteria consist

of a list of those conditions considered to describe the actual occurrence of a failure. These failures resulted either in an automatic loss of component function or the immediate manual removal of the component from service to avoid damage.

The narrow failures are a subset of the broad failures. The use of the narrow definition of failure allows risk to be quantified with data describing failures that certainly took place, without the masking effect caused by information in which less confidence is placed. At the same time, the use of broadly defined failures identifies risk trends that should be investigated further to check their validity. The setting of these criteria is not simple and may involve some iteration with their application, as described in Step 4. The broad and narrow definitions used in this study are given in Section 4.3.

**2.6.4 Step 4. Apply the Failure Criteria to the Time Histories.** The component time histories are reviewed in Step 4 to identify the failures, using both the broad and narrow definitions. The failure criteria defined in Step 3 are updated, as necessary, to incorporate knowledge gained by the in-depth review of the data. This process is detailed in Section 4.4.

**2.6.5 Step 5. Construct Failure Timelines and Cumulative Failure Plots.** It is useful to construct graphical representations before starting more formal statistical analysis to summarize the results. These representations provide a "feel" for the data and allow some simple trends to be immediately identified. However, without statistical analysis of the data, it is difficult to determine whether the apparent trends are statistically significant, and in no case can the trends be quantified. Examples of these graphs are provided in Section 4.5.

**2.6.6 Step 6. Perform Statistical Analysis.** The next step is to model the age-dependent behavior of the components for which time histories have been developed and to estimate model parameters from the data. The failure data, using both the broad and narrow definitions of failure, should be placed in an appropriate format and then analyzed statistically. The approach is explained more fully in Section 5 and carried out

for this demonstration in Section 6. The steps to perform the statistical analysis are explained briefly in the following sections.

**Step 6A. Test for Common  $\beta$  for all Components.** Recall that  $\beta$  governs whether the failure rate is increasing or not. The assumption that the  $\beta$  values for like components are equal should be checked by evaluating the significance level for equality of  $\beta$ . This test is accompanied by a plot of confidence intervals for  $\beta$ , with each interval based on a single component. Although the assumption of a common  $\beta$  was never rejected with the data of this report, the data should routinely be screened in this way for outliers or other evidence of dissimilarity among the components. A decision to delete an outlier should be based on an engineering evaluation, with the goal of understanding the physical process that resulted in the observed anomalous behavior.

**Step 6B. Test For Aging.** Test for the presence of aging by checking the significance level of the null hypothesis ( $\beta = 0$ ) for all sets of components with homogeneous  $\beta$ . As mentioned in Section 2.4, two analyses are performed in this report, one with a critical value of 0.05 and one with a critical value of 0.40. If the significance level is less than the critical value, then the null hypothesis is rejected and the components are considered to be aging. Otherwise, the components are considered to have a constant failure rate. All of the remaining steps below are carried out only if the components are considered to be aging.

**Step 6C. Test Assumed Form of Aging Model.** A graphical check consists of a Quantile-Quantile (Q-Q) plot. If a plot shows no marked divergence of the plotted points from the 45-degree line, then the model appears adequate. If the overall trend in the data shows a marked divergence, such as a large "S" shape, then the assumed aging model appears inadequate to describe the data and should not be applied. Supplementing the plot, the Kolmogorov-Smirnov test can be used as a formal test of the assumed model.

In this report, the Q-Q plots show some indication that the recorded failures tend to cluster in time. Clustering casts doubt on the assumed independence of the failures. For most of the data sets, the clustering was not extreme. For one data set, however, the clustering was severe enough that the Kolmogorov-Smirnov test rejected or nearly rejected any of the models assumed. In the intermediate analysis, the components were modeled as aging, and this data set turned out to be the dominant contributor to the risk caused by aging. Therefore, follow-up inquiries at the plant were made regarding this data set, resulting in a reinterpretation of all those events as non-failures. This reinterpreted data set was used for the final analysis. See Section 6.2.3.

**Step 6D. Test for Common  $\lambda_o$  for All Components.** The assumption that the  $\lambda_o$  values for like components are equal should be tested statistically. This is similar to the test for common  $\beta$ . The assumption never was rejected with the data of this study.

**Step 6E. Find the MLE for  $(\beta, \lambda_o)$ .** Having examined the data and having concluded that the components may be assumed to have a failure rate determined by  $\beta$  and  $\lambda_o$ , the maximum likelihood estimates (MLEs) of these two parameters should be found.

**Step 6F. Check Normal Approximation for Distribution of MLE.** The MLEs for the two parameters yield the MLE for the failure rate  $\lambda(t)$  at any time  $t$ . The MLE is a point estimate only. To also get a confidence band for  $\lambda(t)$ , it is very useful to say that the MLE for  $(\beta, \log \lambda_o)$  has an approximately normal bivariate distribution. This yields a distribution for  $\lambda(t)$  that is approximately lognormal and merges neatly with standard PRA calculations. The check for the adequacy of the normal approximation is graphical. For the data of this demonstration study, approximate normality appeared true when the exponential or Weibull failure model was used. Approximate normality was clearly false with the linear model; much larger data sets would have been needed before the asymptotic normal distribution was approached.

**2.6.7 Step 7. Calculate  $\lambda(t)$ .** For all sets of components that survive the screening of Step 6, the estimated value of  $\lambda(t)$  and its associated confidence interval are calculated as a function of time using statistical analysis techniques. This calculation is explained in Section 5 and carried out in Section 6 using the data of this demonstration study.

**2.6.8 Step 8. Quantify the Age-Dependent Risk.** The final step is to calculate the risk associated with the plant as a function of time. In Step 7, the MLE for  $\lambda(t)$  was found to have an approximately lognormal distribution. For PRA calculations, let this distribution define the Bayesian distribution of  $\lambda(t)$ . This is not the usual way to obtain a Bayesian distribution because it does not involve a prior distribution. It is used because it yields probability intervals that are numerically the same as the confidence intervals, but with a Bayesian interpretation. Based on this distribution, age-dependent basic-event input is

defined to the PRA. The approaches used in PRAs are somewhat plant specific, and the details of the quantification are not presented here. For this study, the Integrated Reliability and Risk Analysis System (IRRAS) computer code was used (Russell et al. 1989).

The results of this time-dependent risk assessment are presented in Section 7. The plant CDF implied by the increasing failure rates of the components is computed and compared to the PRA results that were based on constant failure rates. An approach is suggested in Section 7.2 for using such results in risk-based management of aging components.

The demonstration calculation reported in Section 7 includes only the aging of the components in the AFW system and, therefore, does not include the interaction of the aging of these components with the aging of components in other systems. This interaction is described in Section 7.1.5.



### 3. PWR AUXILIARY FEEDWATER SYSTEM REVIEW

#### 3.1 Design Function

The auxiliary feedwater (AFW) system supplies feedwater to the steam generators following the interruption of the main feedwater supply. If the reactor trips and the main feedwater pumps cease to operate for any reason, feedwater must be provided to remove heat from the reactor coolant system using the steam generators. The AFW system must operate during both normal transient conditions (e.g., unit startup and shutdown) and abnormal transient conditions (e.g., loss of main feedwater, loss of offsite power, and station blackout).

The AFW system design is both redundant (there are two trains in parallel) and separate (the two trains are supplied by different support systems) to ensure its capability to remove heat from the core. As a result of its design, the AFW system can function even in the presence of a single active component failure during the initial demand for the system or a single passive component failure during long-term operation.

#### 3.2 Flowpath

The system is shown schematically in Figure 3-1, and normal system status is summarized in Table 3-1. The normal source of water for the system is the 110,000-gallon condensate storage tank (CST). Each of the three pumps takes its suction from the CST through a dedicated line. If the normal water source is depleted, then one of three backup sources may be lined up to supply water to any or all of the AFW pumps. The lineup is performed by manipulating manually operated valves. The three alternate water sources are the 300,000-gallon CST, the emergency makeup system, and the firewater system.

Three pumps move the water from the various sources to the steam generators. One AFW system train consists of two electric motor-driven pumps configured in parallel, each with a capacity of 350 gpm. The other train consists of a single steam turbine-driven pump, with a capacity of 700 gpm. Flow from each pump discharges

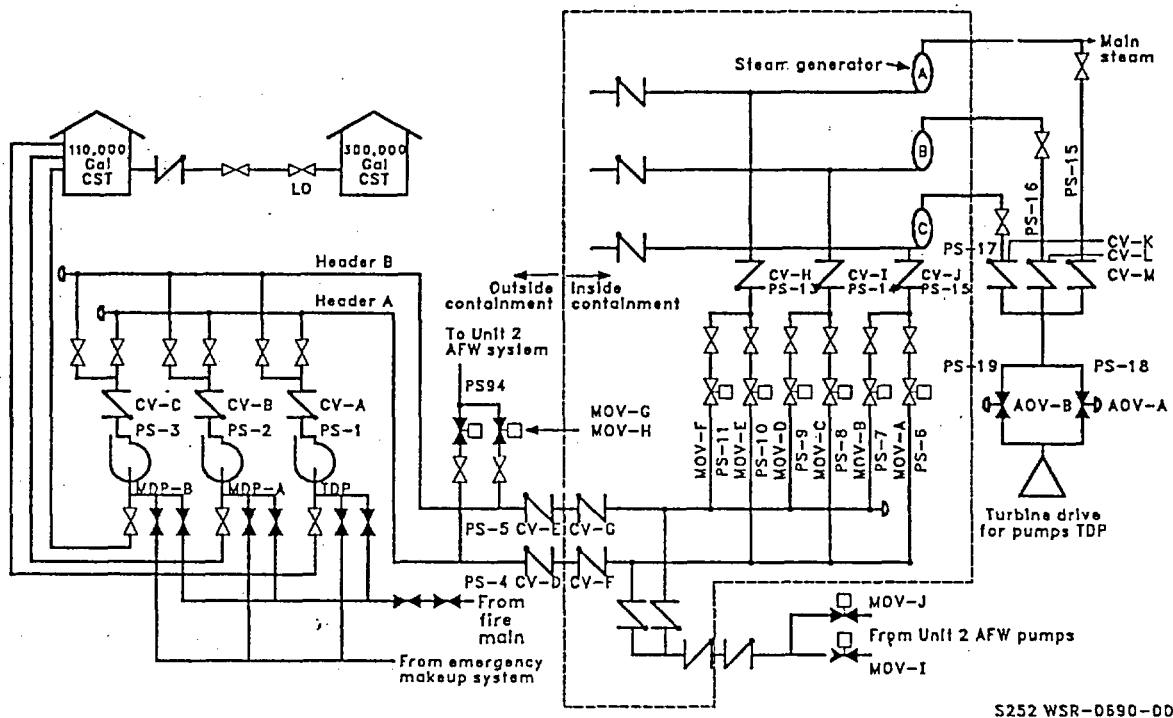


Figure 3-1. Schematic diagram of the PWR auxiliary feedwater system.

**Table 3-1.** PWR AFW system component status and support system dependency summary.

Component	Normal status	Support system dependency	Response to support system failure
<i>Pumps</i>			
MDP-A	Standby	ac Bus 1H dc Bus 1A	Failure to start or run
MDP-B	Standby	ac Bus 1J dc Bus 1B	Failure to start or run
TDP	Standby	Main Steam	Failure to start or run
<i>Motor Operated Valves</i>			
MOV-A, -C, -E	Normally open	ac Bus 1H	Fails as is
MOV-B, -D, -F	Normally open	ac Bus 1J	Fails as is
MOV-G	Normally closed	ac Bus 1H	Fails as is
MOV-H	Normally closed	ac Bus 1J	Fails as is
MOV-I	Normally closed	ac Bus 2H	Fails as is
MOV-J	Normally closed	ac Bus 2J	Fails as is
<i>Air Operated Valves</i>			
AOV-A	Normally closed	Instrument Air dc Bus 1A	Fails open Fails open
AOV-A	Normally closed	Instrument Air dc Bus 1A	Fails open Fails open

through a unique discharge isolation check valve (CV-A, -B, or -C) and then joins flow from the other pumps in the two combined flow headers (PS-4 and -5). Normally open manual isolation valves can be used to isolate any pump from either of the combined flow headers.

A cross-connect tap on each combined flow header allows flow from one or both of the headers to be sent to the other unit. The taps are located outside of containment, upstream of the containment isolation check valves. Each of the supply lines to the opposite unit contains a normally open manual

isolation valve and a normally shut motor-operated valve (MOV) (MOV-G and -H). Flow in each of the combined headers passes through an outboard containment isolation check valve (CV-D or -E), through the containment wall, and then through an inboard isolation check valve (CV-F or -G). A cross-connect tap on each combined flow header downstream of the containment isolation check valves allows flow from the other unit's AFW system to be supplied to one or both of the combined flow headers. Backflow to the other unit via the supply line is prevented by two

check valves and a normally closed MOV (MOV-I and -J).

Flow from each of the combined flow headers branches into six individual headers (PS-6 to -11) downstream of the supply cross-connect from the other unit. Each of the six individual headers contains a normally open MOV (MOV-A to -F) and a stop valve. These six individual headers are then combined in twos, one from each of the combined flow headers, to make three new flow headers (PS-13, -14, and -15). One each of the three new flow headers is used to feed one of the three steam generators via the normal feedwater piping. Backflow from the normal feedwater system is prevented by a check valve (CV-H, -I, and -J) in each of the three AFW headers. The AFW flow taps into the feedwater line with no valves between the tap and the steam generator.

### 3.3 Support Systems

Numerous systems support the successful operation of the AFW system. Table 3-1 contains a summary of support system dependencies and responses to failure. Suction water is normally supplied from the condensate system, but may also be supplied from an emergency makeup system or from the fire main. Electrical motive power is supplied to the motor-driven AFW pumps from the ac emergency power busses. Bus 1H supplies the 3A pump, and Bus 1J supplies the 3B pump. Motive power in the form of steam is supplied to the turbine-driven AFW pump from each of the three steam generators. The supply lines (PS-15, -16, and -17) tap off the main steam lines between the steam generators and the main steam isolation valves (see schematic in Figure 3-1). The three tap lines combine into a single header and then split into two lines (PS-18 and -19), each of which contains an air-operated valve (AOV-A and -B) that is normally closed, but will open to start steam flow to the turbine-driven pump. Emergency dc power can be supplied to control all the pumps. Bus 1A supplies control power for the 3A pump, and Bus 1B supplies control power for the 3B pump. Failure of dc control power will fail the associated

motor-driven pump. Busses 1A and 1B supply the control power for the air system, which in turn supplies the control air for the air-operated valves that control the steam supply to the turbine-driven AFW pump. Failure of dc power or air to the turbine-driven pump control system will cause the air-operated valves to fail open, resulting in the start of the turbine-driven AFW pump. DC control power is also used to control and position the motor-operated valves in the six branch lines and in the cross-connect lines. The valves fail as is on loss of power. Finally, the automatic actuation of the AFW system is dependent on the actuation signals discussed in detail in the next section.

### 3.4 Automatic Actuation and System Response

The supply circuit breakers for the motor-driven AFW pumps will receive a signal to close and the pumps will start automatically upon receiving any one of the following signals:

1. Safety injection actuation signal
2. Trip of the main feedwater pumps
3. Low level in any steam generator
4. Loss of offsite power.

The air-operated steam supply valves for the turbine-driven AFW pump will receive a signal to open and the pump will start automatically upon receiving any one of the following signals:

1. Low level in any two steam generators
2. Undervoltage on any reactor coolant system main pump bus.

In addition to starting the pumps, the above signals will also cause an open signal to be sent to all six of the normally open MOVs in the six individual headers.

## 4. COMPONENT FAILURE DATA

The process used in developing the plant-specific AFW system component failure data is illustrated in Figure 4-1. The individual steps represented in the figure are described in the following sections.

### 4.1 Component History

The first step was to obtain historical information pertaining to the components of interest. Numerous sources were available, including maintenance records, operating logs, and monthly summaries. The combination of information from all of the sources would obviously result in the most comprehensive and reliable history. Often, however, in the interest of time and money, only a select few sources would be used. Such was the case for this study, and only documentation obtained from the maintenance work order system of an older, dual-unit PWR nuclear power station was used to develop component histories.

The maintenance records for the station were grouped by major system, with the AFW system records mixed with the main feedwater (FW) and the emergency feedwater (EFW) system records. Plant piping and instrument diagrams were used in conjunction with the maintenance records to distinguish components among these three systems. A total of 1156 AFW events were thus identified for further analysis.

The data were received encoded in the following data structure:

Mark Number	Alpha-numeric identification for the component. In fact, this number refers to a component location in the plant system.
Component	Type name of the component.
Problem Description	A very brief and typically cryptic explanation of why work was performed on the component.

History Summary	A very brief summary of what repairs were performed on the component.
Return to Service Date	The day that the component was declared fully operational.
Maintenance Record Number	An identification number sequentially assigned to each maintenance work order.

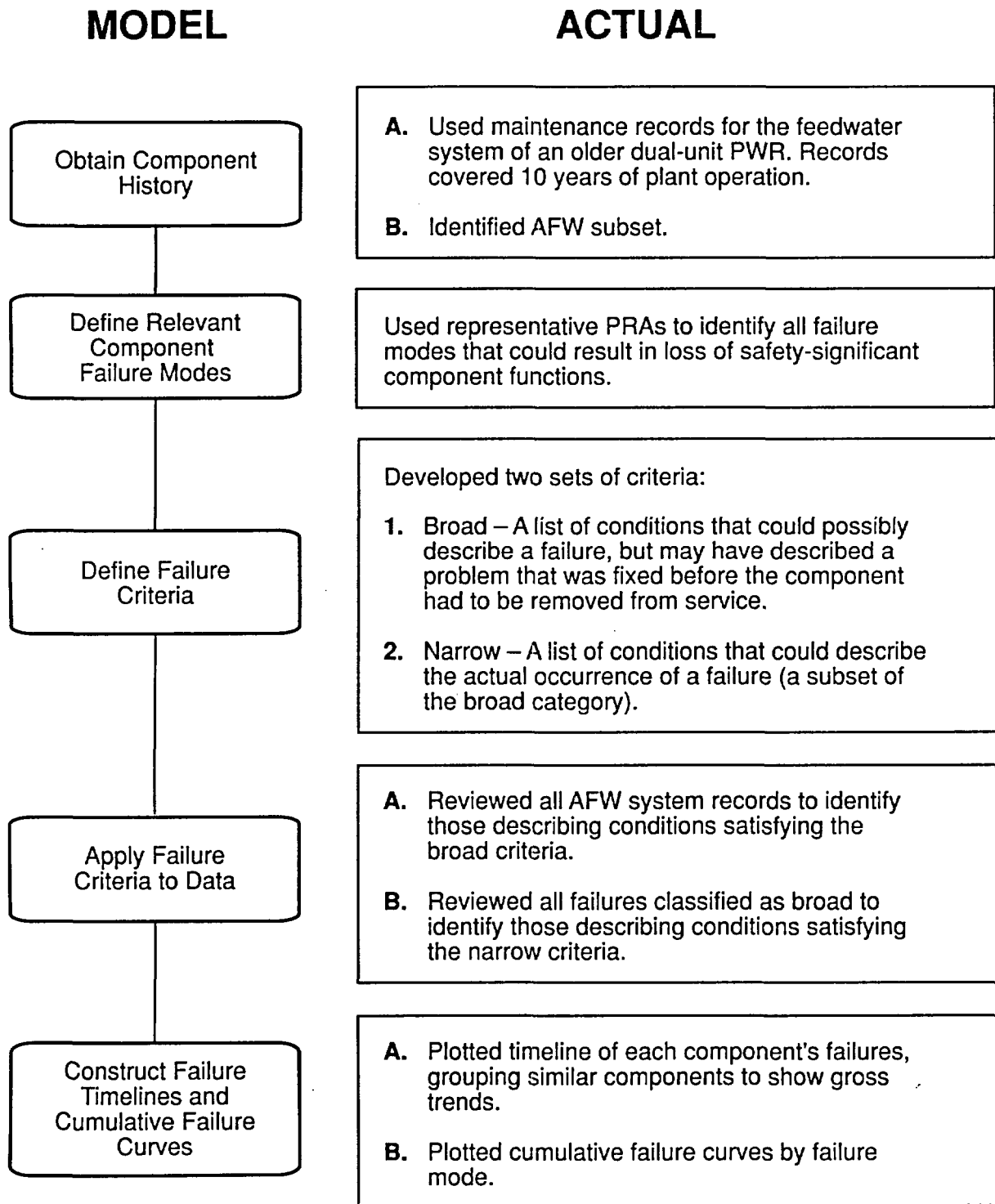
The preceding structure represents the expected minimum, or rudimentary, data structure present in any given nuclear power plant.

To facilitate development of failure data for subsequent statistical analysis, these additional categories were added to the data.

Component Type	A consistent component type definition. <sup>b</sup>
Classification	A code reflecting the final classification of the record as either describing a failure or describing some other maintenance action.
Replace	A flag indicating complete component replacement events.
Number of Replacements	The running total number of replacements for the particular component location (mark number).

Notes on specific alterations or changes in the data (e.g., correction of misspellings or standardization of formats for consistency) were maintained in a change field, unique to each record. After the standardization, the AFW component

b. As an example, three separate, independent maintenance activities on a single 3-in. check valve referred to the valve as a "valve," a "check valve," and an "isolation valve" in the component field of the maintenance work order documentation.



LF91 0312

**Figure 4-1.** Process used to develop component failure data.

event records were sorted and then segregated into 12 major component groups, as shown in Table 4-1.

**Table 4-1.** Distribution of raw maintenance events for the AFW system according to component type.

Component type	Number of events
Steam-driven pump (TDP)	190
Motor-driven pump (MDP)	262
3-in. motor-operated valve (MOV) (individual feed header isolation)	354
6-in. motor-operated valve (MOV) (cross-connect header isolation)	54
1-in. check valve (CV) (pump recirculation)	11
3-in. check valve (CV) (individual feed header)	44
4-in. check valve (CV) (pump discharge header)	11
6-in. check valve (CV) (pump discharge header)	9
6-in. check valve (CV) (combined feed header)	28
Stop valves (various)	61
Piping (various)	111
Instruments (various)	21
Total	1156

## 4.2 Definition of Relevant Component Failure Modes

A list of 15 component failure modes (basic events) was developed from a survey of the AFW models contained in three representative PRAs. Table 4-2 lists these AFW component failure modes. The component numbers can be matched to the component locations on the AFW system schematic shown in Figure 3-1. Because the data were incomplete, we made no attempt to quantify the two failure modes involving unavailability resulting from testing or maintenance. The remaining 13 modes were considered in the failure evaluations described in Sections 4.3 and 4.4.

The system boundaries used to establish the failure modes in Table 4-2 are basically evident by inspection of the modes. The following specific ground rules were used to develop the component boundaries in the NUREG-1150 PRA (USNRC 1989) and to develop the failure criteria in the following section:

- Assume pump and valve breakers and control circuits are part of the component
- Model ac and dc power to the breaker and control circuits as a separate support system and, thus, not an AFW failure mode.

## 4.3 Definition of Failure Criteria

Failure modes for the components of the AFW system were described in the previous section. The interpretation of the maintenance records to determine which ones indicated the presence of a failure was subjective. Because the information in the records was not designed for the development of failure tracking, the information was imprecise concerning the exact condition of the component. In order to bracket this subjectivity and to facilitate a more repeatable analysis, or comparison with similar analyses, it was necessary to develop a set of criteria to define when a failure mode was satisfied. To cover the spectrum of events that might reasonably be considered failures, two sets of criteria were developed for each failure mode.

## Component Failure Data

**Table 4-2.** AFW system component failure modes, descriptions, and relevant component numbers, corresponding to Figure 3-1.

Failure mode	Description
AFW-ACT-FA-PMP-*	No actuation signal to pump. *MDP-A, -B
AFW-ACT-FA-*	No actuation signal to steam supply valve. *AOV-A, -B
AFW-AOV-LF-*	Loss of flow through steam supply valve. *AOV-A, -B
AFW-CKV-FT-*	Check valve fails to open. *3 in. CV-H, -I, -J; 4 in. CV-B, -C; 6 in. CV-A, -D, -E, -F, -G; Main Steam, 3 in., CV-K, -L, -M.
AFW-CKV-OO-*	Backflow through pump discharge check valve. *CV-A, -B, -C
AFW-MOV-PG-*	Motor-operated valve plugged. *MOV-A, -B, -C, -D, -E, -F
AFW-PMP-LK-STMBD-*	Undetected, simultaneous leakage through one of the following combinations of check valves: [At least one of CV-H, -I, -J] and [either CV-D and -F or CV-E and -G] and [CV-A for *TDP or CV-B for *MDP-A; CV-B or CV-C for *MDP-B].
AFW-PMP-FR-*	Pump fails to run. *TDP, MDP-A, -B
AFW-PMP-FS-*	Pump fails to start. *TDP, MDP-A, -B
AFW-PMP-TM-*	Pump unavailable due to testing or maintenance. *TDP, MDP-A, -B
AFW-PSF-FC-XCONN-*	Flow diversion to opposite unit through motor-operated valves. *MOV-G, -H, -I, -J
AFW-PSF-LF-*	Faults in pipe segments. *Various pipe segments.
AFW-TNK-VF-CST	Insufficient water available from 110,000-gal condensate storage tank.
AFW-XVM-PG-XV-*	Manual valve plugged. *Various manual valves.
AFW-*-TM-*	Component unavailable due to testing or maintenance. *Any AFW component in testing or maintenance when it is required to be in service.

\* Refers to the components listed at the end of the associated description. For example, the two failure modes corresponding to the first entry of the table are AFW-ACT-FA-PMP-MDP-A for motor-driven pump A and AFW-ACT-FA-PMP-MDP-B for pump B.

The first set of criteria was developed for what is called a "broad" definition of failure. The criteria consist of conditions that could possibly have described a failure, but which may have described a problem that was fixed before the component had to be removed from service. For example, a failure record for steam-driven pumps was considered to describe a broad failure if it stated one of the following:

1. Conditions existed that led to the repair of the lubricating oil cooling system.
2. Conditions existed that led to a bearing repair or replacement.
3. Conditions existed that led to the repair of the trip/governor valve.
4. Conditions of high vibration existed.
5. Conditions existed that led to the repair of the pump for some unspecified reason.
6. Conditions existed that led to a control system repair.
7. Pump failed to start or run.

Records that were not considered as failures by the broad definition included those resulting from preventive maintenance programs (including planned overhauls), design changes, functionally unimportant boundary leaks, gauge replacements, and minor deficiency repairs. Also removed were failures that resulted directly from improperly performed maintenance, such as a failure of the turbine-driven feed pump from overpressurization caused by an improper valve lineup during a surveillance test.

The second set of criteria was developed for a "narrow" definition of failure. The criteria consist of those conditions considered to describe the actual occurrence of a failure. These failures resulted either in an automatic loss of component function or the immediate manual removal of the component from service to avoid damage. For example, a failure record for steam-driven pumps

was considered to describe a narrow failure if it stated one of the following:

1. The pump failed to start or run.
2. A gross loss of lubrication occurred.
3. The governor valve did not open.
4. Gross vibration occurred.

The narrow failures are a subset of the broad failures. Risk can be quantified with the narrow definition of failure (using data describing failures that certainly took place) to avoid the masking effect caused by information in which less confidence is placed. At the same time, risk trends can be identified with the broadly defined failures that should be investigated further to check their validity. Setting these criteria was not simple and involved some iteration with their application.

#### 4.4 Application of Failure Criteria to the Data

**4.4.1 Broadly Defined Failure Data.** The 1156 records were evaluated carefully to determine which ones indicated that a broadly defined failure had occurred. There were 163 broad failure records identified in the maintenance events distributed across component types, as indicated in Table 4-3. These 163 records were reduced to 118 failure events distributed across failure modes, as indicated in Table 4-4. The reduction occurred because, on occasion, several maintenance records described the same failure event. Note that evidence of only 6 of the 13 failure modes was found in the documentation. The following paragraphs describe the logic employed in evaluating the maintenance data for broadly defined failures, as well as the logic for classification of the remainder of the events as non-failures. Table B-1 in Appendix B lists the AFW records grouped by component type, indicating failure classification by record. Table 4-5 is a short sample of entries from Table B-1. In Table B-2 of Appendix B, all the non-failure records in



## Component Failure Data

**Table 4-3.** Distribution of broadly defined failure occurrences according to component type.

Component type	Number of failure records
Steam-driven pump (TDP)	28
Motor-driven pump (MDP)	27
3-in. motor-operated valve (MOV) (individual feed header isolation)	45
6-in. motor-operated valve (MOV) (cross-connect header isolation)	15
3-in. check valve (CV) (individual feed header)	18
4-in. check valve (CV) (pump discharge header)	8
6-in. check valve (CV) (pump discharge header)	6
6-in. check valve (CV) (combined feed header)	16
Stop valves (various)	0
Piping (various)	0
Instruments (various)	0
<b>Total</b>	<b>163</b>

Table B-1 have been removed, and only the records fitting the broad definition of failure remain. Table 4-6 is a sample portion of records from Table B-2. To assist further in the evaluation of the failures, the "Problem Description" and "History Summary" sections for each of the

**Table 4-4.** Distribution of broadly defined failure occurrences according to failure mode.

Failure mode	Number of failures
AFW-ACT-FA-PMP	0
AFW-ACT-FA	0
AFW-AOV-LF	0
AFW-CKV-FT	0
AFW-CKV-OO	12, 0 <sup>a</sup>
AFW-MOV-PG	41
AFW-PMP-LK-STMBD	2
AFW-PMP-FR-MDP	11
-TDP	24
AFW-PMP-FS-MDP	16
-TDP	0
AFW-PSF-FC-XCONN	12
AFW-PSF-LF	0
AFW-TNK-VF-CST	0
AFW-XVM-PG	0
<b>Total</b>	<b>118, 106<sup>a</sup></b>

a. Twelve events were initially classified as back-flow failures of check valves. After discussion with personnel from the power station, these events were all reinterpreted as non-failures. See Section 6.2.3.

163 broadly defined failures were rewritten in a more readable format as the "Problem/Repair Summary." Table B-3 in Appendix B contains the rewritten records, and a sample portion is shown in Table 4-7. (Refer to Appendix B for the specific records described in the following discussion.)

**Table 4-5.** Sample of maintenance records for the AFW system steam-driven pumps (excerpted from Table B-1).

Mark number	Component	Maintenance request number	Problem description	Mode/mechanism (if applicable) history summary	Return to service date <sup>a</sup> / classification <sup>b</sup>
1-TDP	Pump	801010430	Gross oil-low discharge pressure	Renewed thrust bearing linings	780111 FR
1-TDP	Pump	803030420	Excessive discharge PREE-PT15	Reduced speed of Pump at governor	780303 FR
1-TDP	Valve	10176160	Body to bonnet leak	Renewed bonnet gasket	780508 BL
1-TDP	Pump	901030450	Gov valve will not control pump speed	Fixed satisfactory	790204 FR
2-TDP	Pump	901261550	Refuel PMS	Did PMS checks	790228 PMS
1-TDP	Turb	810040500	Various repairs trip valve	Repaired and tested governor	790420 FR
2-TDP	Pump	902131328	Oil cooler end bell cracked	Void	790420 VOID
1-TDP	Pump	905021900	Drain, clean, inspect sump refill	Drained oil, cleaned sump	790515 PMS
1-TDP	Pump	905181332	Sight glass has oil leak	Tightened sight glass	790611 MD
1-TDP	Pump	902040100	Head gasket leaks on pump	Void	790917 VOID
1-TDP	Pump	905101032	Adjust packing	Void	790917 VOID
1-TDP	Turb	811030530	Governor valve inoperative	Void	791002 VOID
1-TDP	Instr	910201310	Replace gauge and repair leak	Replaced gauge	791102 GAUGE
1-TDP	Pump	911011230	Oil leak on pump	Repaired Pump and held pm check	791116 MD
2-TDP	Pump	902201305	PMS as per MMP-P-FW-004	Void	791128 VOID
1-TDP	Valve	910201305	Replace handwheel	Found handwheel to be properly installed	791209 MD
1-TDP	Pump	912172125	Outboard pump bearing	Renewed thrust bearing throwing oil	791223 FR
1-TDP	Pump	1240708	Oil seal packing leak	Renewed thrust shoe	800210 FR
2-TDP	Instr	2191428	Deficiency punch list	Replaced glass	800319 MD
1-TDP	Instr	4131129	Broken case switch	Installed new switch	800429 FR

a. Note that date format is year, month, and day.

b. PMS - preventive maintenance; BL - boundary leak; VOID - record voided; MD - minor deficiency; GAUGE - gauge replacement or calibration; FR - failure to run.

**Table 4-6.** Sample of maintenance records broadly classified as failures for the AFW system steam-driven pumps (excerpted from Table B-2).

Mark number	Component	Maintenance request number	Problem description	Mode/mechanism (if applicable) history summary	Return to service date <sup>a</sup> / classification <sup>b</sup>
1-TDP	Pump	801010430	Gross oil-low discharge	Renewed thrust bearing linings pressure	780111 FR
1-TDP	Pump	803030420	Excessive discharge	Reduced speed of pump at governor PREE-PT15	780303 FR
1-TDP	Pump	901030450	Gov valve will not control	Fixed satisfactory pump speed	790204 FR
1-TDP	Turb	810040500	Various repairs	Repaired and tested governor trip valve	790420 FR
1-TDP	Pump	912172125	Outboard pump bearing	Renewed thrust bearing throwing oil	791223 FR
1-TDP	Pump	1240708	Oil seal packing leak	Renewed thrust shoe	800210 FR
1-TDP	Instr	4131129	Broken case switch	Installed new switch	800429 FR
2-TDP	Pump	11170730	Overspeed trip valve trips	Straightened linkage	801118 FR
2-TDP	Pump	205081945	Governor set at 4060 RPM	Reset RPM to 3880	820513 FR
1-TDP	Pump	208132145	Repair oil leak	Changed thrust shaft collar journal	820824 FR
2-TDP	Governor	212061305	Repair feedback arm	Reinstalled setscrew	821207 FR
2-TDP	Pump	302111050	Pump trips	Adjusted overspeed trip	830216 FR
2-TDP	Pump	303101430	Set screw missing	Adjusted damper	830314 FR
2-TDP	Pump	303181232	Overspeed trip	Put spring back on hook	830321 FR
2-TDP	Pump	304250400	Oil seal leaking	Replaced bearing and thread shoes	830429 FR
2-TDP	Bearing	306200726	Replace bearing	Replaced bearing and shoes	830927 FR
2-TDP	Pump	309271700	High bearing vibrations	Adjusted linkage	831013 FR
1-TDP	PMP Gov	312311328	Repair governor	Installed new seat	840111 FR
2-TDP	Switch	402240947	Pump will not cut off in auto	Checked switch	840330 FR
1-TDP	Pump	14061	Mechanical linkage broken	Reinserted rod and closed socket ends around ball tip	850214 FR

a. Note that date format is year, month, and day.

b. FR - failure to run.

**Table 4-7.** Sample of maintenance records broadly classified as failures for the AFW system steam-driven pumps, rewritten format (excerpted from Table B-3).

Mark number	Component	Maintenance request number	Problem/repair summary	Return to service date <sup>a</sup> / classification <sup>b</sup>
1-TDP	Pump	801010430	The lubricating oil pressure failed low resulting in bearing damage, replaced thrust bearing lining.	780111 FR
1-TDP	Pump	803030420	The pump discharge pressure was high, adjusted the governor to reduce the pump speed and thus discharge pressure.	780303 FR
1-TDP	Pump	901030450	The governor valve was not controlling pump speed, governor was repaired in some manner.	790204 FR
1-TDP	Turb	810040500	Various non-specified repairs were made to the pump, the pump was returned to service.	790420 FR
1-TDP	Pump	912172125	The outboard pump bearing was throwing enough oil that it was necessary to renew the thrust bearing.	791223 FR
1-TDP	Pump	1240708	An oil seal packing leak was large enough that it was necessary to renew the thrust bearing shoe.	800210 FR
1-TDP	Instr	4131129	A broken case switch associated with the discharge pressure trip was found and replaced.	800429 FR
2-TDP	Pump	11170730	Deficiencies in the overspeed trip valve caused a pump trip, the linkage was straightened.	801118 FR
2-TDP	Pump	205081945	The governor was controlling pump speed high at 4060 rpm, it was reset to control at 3880 rpm.	820513 FR
1-TDP	Pump	208132145	An oil leak was large enough that it was necessary to replace some bearings.	820824 FR
2-TDP	Governor	212061305	The feedback arm of the governor was not working correctly, a setscrew was installed.	821207 FR
2-TDP	Pump	302111050	The overspeed trip caused inappropriate pump trips, the overspeed trip was correctly adjusted.	830216 FR

a. Note that date format is year, month, and day.

b. FR - failure to run.

## Component Failure Data

**Main AFW Steam-Driven Pumps (AFW-PMP-FR-TDP and AFW-PMP-FS-TDP).** A failure record was considered to describe a broad failure if it stated one of the following:

1. Conditions existed that led to the repair of the lubricating oil cooling system.
2. Conditions existed that led to a bearing repair or replacement.
3. Conditions existed that led to the repair of the trip/governor valve.
4. Conditions of high vibration existed.
5. Conditions existed that led to the repair of the pump for some unspecified reason.
6. Conditions existed that led to a control system repair.
7. Pump failed to start or run.

Of the 190 records, 28 were determined to fit the broad failure category. Four of these 28 were determined to reflect previous failure events, and thus 24 unique failures were seen. The items eliminated from failure consideration were 47 void records, 17 packing leaks, 25 preventive maintenance items, 23 gauge replacements/calibrations, 30 minor deficiencies, 10 design changes, seven nonfunctional failures, and three failures caused by improperly performed maintenance.

**Main AFW Motor-Driven Pumps (AFW-PMP-FR-MDP and AFW-PMP-FS-MDP).** A failure record was considered to describe a broad failure if it stated one of the following:

1. Conditions existed that led to the repair of the lubricating oil cooling system.
2. Conditions existed that led to a bearing repair or replacement.
3. The motor heaters failed.
4. Conditions existed that led to the repair of the pump for some unspecified reason.

5. Conditions existed that led to an electrical control system repair.
6. Pump failed to start or run.

Of the 262 records, 27 were determined to fit the broad failure category. The items eliminated from failure consideration were 46 void records, 44 packing leaks, 52 preventive maintenance items, 28 gauge replacements/calibrations, 55 minor deficiencies, seven design changes, and three failures caused by improperly performed maintenance.

**3-In. MOV (Individual Feed Header Isolation, AFW-MOV-PG).** A failure record was considered to describe a broad failure if it stated one of the following:

1. Conditions existed that led to an electrical control system repair. (All torque switch problems were considered failures, but adjustment of limit switches was generally not considered a failure.)
2. Mechanical binding/obstruction was noted.
3. Valve was replaced.
4. Supply breaker tripped.
5. Valve failed to open or stay open.

Of the 354 records, 45 were determined to fit the broad failure category. Four of these were determined to reflect previous failure events, and thus 41 unique failures were seen. The items eliminated from failure consideration were 66 void records, 37 pressure boundary leaks, 112 preventive maintenance items, 21 seat leaks, 14 limit switch malfunctions, 37 design changes, 20 minor deficiencies, and two failures caused by improper maintenance.

**6-In. MOV (Cross-Connect Header Isolation, AFW-PSF-FC-XCONN).** A failure record was considered to describe a broad failure if it stated one of the following:

1. Conditions existed that led to an electrical control system repair. (All torque switch problems were considered failures, but

adjustment of limit switches was generally not considered a failure.)

2. Mechanical binding/obstruction was noted.
3. Valve was replaced.
4. Supply breaker tripped.
5. Valve failed to close or stay closed.

Of the 54 records, 15 were determined to fit the broad failure category. The items eliminated from failure consideration were 19 void records, one boundary leak, 14 preventive maintenance items, one limit switch malfunction, and four minor deficiencies.

**3-, 4-, and 6-In. Check Valves (Individual, Combined, and Pump Discharge Headers AFW-CKV-FT, AFW-CKV-OO, and AFW-PMP-LK-STMBD).** A failure record was considered to describe a broad failure if it stated one of the following:

- For the failure-to-open mode:
  - The valve failed to open.
- For the backflow mode (applicable only to pump discharge check valves):
  1. Conditions existed that led to the repair of the valve seat or disc.
  2. Seat leakage occurred.
- For the steam binding mode:
  1. Conditions existed that led to the repair of the valve seat or disc.
  2. Seat leakage occurred.

Of the 92 records, none indicated a failure to open, but 14 were determined to fit the broad definition of backflow and 48 were determined to indicate leakage that might lead to steam binding. The 14 backflow records were a subset of the records that contributed to steam binding. Two of these 14 were determined to reflect previous

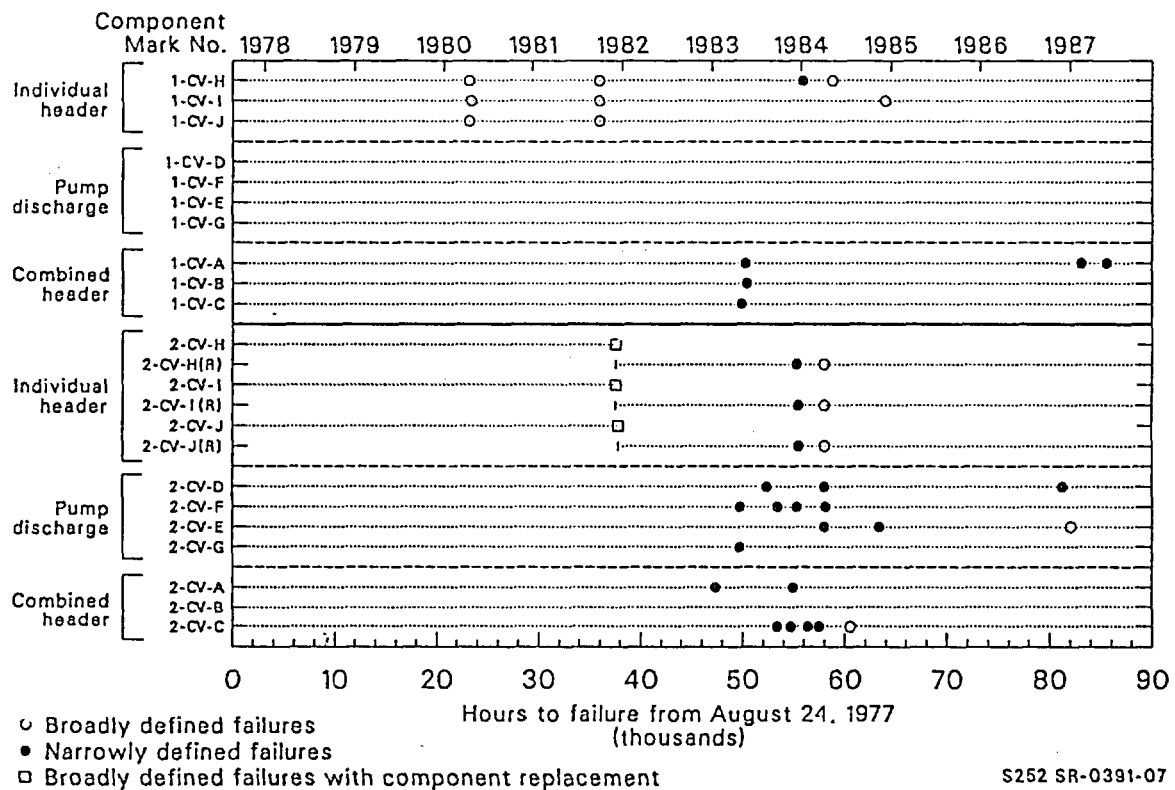
failure events, and thus 12 unique failures were seen. The remaining 44 records were eliminated: 19 void records, nine preventive maintenance items, and 16 boundary leaks.

As noted in Table 4-2, for steam binding to occur, one of the three 3-in. (CV-H, -I, and -J) check valves had to leak simultaneously with either of the two 6-in. combined header check valves (CV-D and -F or CV-E and -G) and one pump discharge check valve (CV-A, -B, or -C). A failure timeline containing all 48 broadly defined check valve failures was constructed to search for combinations that could lead to failure (Figure 4-2). Failure could have occurred on one occasion each for a steam-driven pump and a motor-driven pump (MDP-B), both in Unit 2. Thus, only two broadly defined occurrences of steam binding were observed.

**1-In. Check Valves, Stop Valves, Piping, and Instruments.** None of the 204 records in these four categories were determined to be broad failures for the following reasons: none of the stop valves became plugged; none of the instrument failures caused failure of any associated equipment; and neither 1-in. check valves nor pipe failures were modeled in the PRA. The records included minor valve deficiencies, piping support deficiencies, gauge calibrations/replacements, and preventive maintenance items.

**4.4.2 Narrowly Defined Failure Data.** A small fraction of the maintenance narrative records (5%) contained sufficient information to fit the category of a narrowly defined failure. These were determined by careful reevaluation of the 163 broad failure records, as shown in Table B-3 of Appendix B. The 72 narrowly defined failure records are shown in Table B-4 of Appendix B. A sample portion of Table B-4 is shown in Table 4-8. The distribution of the 72 failure records across component types is shown in Table 4-9. The 72 failure records were reduced to 35 failure events distributed across failure mode, as shown in Table 4-10. The reduction occurred because, on occasion, several maintenance records described the same failure event. The following paragraphs present the logic used

## Component Failure Data



**Figure 4-2.** Failure timelines to determine the occurrence times of steam binding of the AFW system pumps.

to determine which of the broadly defined failure records could be classified as failures by the narrow definition.

**Main AFW Steam-Driven Pumps (AFW-PMP-FR-TDP and AFW-PMP-FS-TDP).** A failure record was considered to describe a narrow failure if it stated one of the following:

1. The pump failed to start or run
2. A gross loss of lubrication occurred
3. The governor valve did not open
4. Gross vibration occurred.

Of the 28 broadly defined failures, only nine were determined to fit the narrow failure category. Four of these nine were determined to reflect previous failure events, and thus five unique failures were seen. Records representing apparently minor deficiencies not

considered to be failures were eight bearing/lubrication deficiencies, nine control valve deficiencies, one nonspecified pump repair, and one vibration event.

**Main AFW Motor-Driven Pumps (AFW-PMP-FR-MDP and AFW-PMP-FSR-MDP).** A failure record was considered to describe a narrow failure if it stated one of the following:

1. The pump failed to start or run
2. The supply breaker tripped
3. A gross loss of lubrication occurred
4. Gross vibration occurred.

Of the 27 broadly defined failures, only four were determined to fit the narrow failure category. Records representing apparently minor deficiencies not considered to be failures were nine lube oil cooler deficiencies, one bearing/

**Table 4-8.** Sample of maintenance records narrowly classified as failures for the AFW system steam-driven pumps, rewritten format (excerpted from Table B-4).

Mark number	Component	Maintenance request number	Problem/repair summary	Return to service date <sup>a</sup> / classification <sup>b</sup>
1-FW-P-2	Pump	801010430	The lubricating oil pressure failed low resulting in bearing damage, replaced thrust bearing lining.	780111 FR
2-FW-P-2	Pump	11170730	Deficiencies in the overspeed trip valve caused a pump trip, the linkage was straightened.	801118 FR
2-FW-P-2	Pump	302111050	The overspeed trip caused inappropriate pump trips, the overspeed trip was correctly adjusted.	830216 FR
2-FW-P-2	Pump	303181232	Failure of the overspeed trip spring to stay engaged led to a pump trip, the spring was reinstalled.	830321 FR
1-FW-P-2	Pump	40487	The governor valve would not open, spring was replaced but this did not help.	860907 FR
1-FW-P-2	Pump	41325	Governor was removed and overhauled because poor operation. (This event was combined with record 40487)	860927 FR
1-FW-P-2	Pump	40450	Additional governor work combined with record 40487.	860930 FR
1-FW-P-2	Pump	40488	Additional governor work combined with record 40487.	860930 FR
1-FW-P-2	Pump	40491	Additional governor work combined with record 40487.	860930 FR

a. Note that date format is year, month, and day.

b. FR - failure to run.



## Component Failure Data

**Table 4-9.** Distribution of narrowly defined failure occurrences according to component type.

Component type	Number of failure records
Steam-driven pump (TDP)	9
Motor-driven pump (MDP)	4
3-in. motor-operated valve (MOV) (individual feed header isolation)	22
6-in. motor-operated valve (MOV) (cross-connect header isolation)	7
3-in. check valve (CV) (individual feed header)	4
4-in. check valve (CV) (pump discharge header)	7
6-in. check valve (CV) (pump discharge header)	6
6-in. check valve (CV) (combined feed header)	13
Stop valves (various)	0
Piping (various)	0
Instruments (various)	0
<b>Total</b>	<b>72</b>

lubrication deficiency, one vibration event, four slow pump starts, three motor wetting events, and five heater failures.

**3-In. MOV (Individual Feed Header Isolation, AFW-MOV-PG).** A failure record was considered to describe a narrow failure if it stated one of the following:

**Table 4-10.** Distribution of narrowly defined failure occurrences according to failure mode.

Failure mode	Number of failures
AFW-ACT-FA-PMP	0
AFW-ACT-FA	0
AFW-AOV-LF	0
AFW-CKV-FT	0
AFW-CKV-OO	0
AFW-MOV-PG	18
AFW-PMP-LK -STMBD	2
AFW-PMP-FR -MDP	0
-TDP	5
AFW-PMP-FS -MDP	4
-TDP	0
AFW-PSF-FC-XCONN	6
AFW-PSF-LF	0
AFW-TNK-VF-CST	0
AFW-XVM-PG	0
<b>Total</b>	<b>35</b>

1. The valve failed closed
2. The valve failed to open
3. The valve was stuck (no specified direction)
4. The supply breaker tripped.

Of the 45 broadly defined failures, only 22 were determined to fit the narrow failure category. Four of these 22 were determined to reflect previous failure events, and thus 18 unique

failures were seen. Records representing apparently minor deficiencies not considered to be failures were eight control deficiencies, nine mechanical deficiencies, and six failure-to-close events.

**6-In. MOV (Cross-Connect Header Isolation, AFW-PSF-FC-XCONN).** A failure record was considered to describe a narrow failure if it stated one of the following:

1. The valve failed open
2. The valve failed to close
3. The valve was stuck (no specified direction)
4. The supply breaker tripped.

Of the 15 broadly defined failures, only seven were determined to fit the narrow failure category. One of these seven was determined to reflect a previous failure event, and thus six unique failures were seen. Records representing apparently minor deficiencies not considered to be failures were one control deficiency, three mechanical deficiencies, and four failure-to-close events.

**3-, 4-, and 6-In. Check Valves (AFW-CKV-OO and AFW-PMP-LK-STMBD).** A failure record was considered to describe a narrow failure if it stated one of the following:

- For the backflow mode (applicable only to the pump discharge check valves): gross seat leakage occurred.
- For the steam binding mode: seat leakage occurred.

Of the 48 broadly defined failures, none were determined to fit the narrow category of backflow failure, and 30 were determined to fit the narrow failure category for steam binding failure. Records representing apparently minor deficiencies not considered failures were 18 valve inspections/overhauls where the record did not state that the valve had been leaking.

A failure timeline was constructed to search for those combinations of valves leading to steam binding, as was done for the broadly defined failures (Figure 4-2). Failure could have occurred on one occasion each for a steam-driven pump and a motor-driven pump (MDP-B), both in Unit 2. Thus, only two narrowly defined occurrences of steam binding were observed.

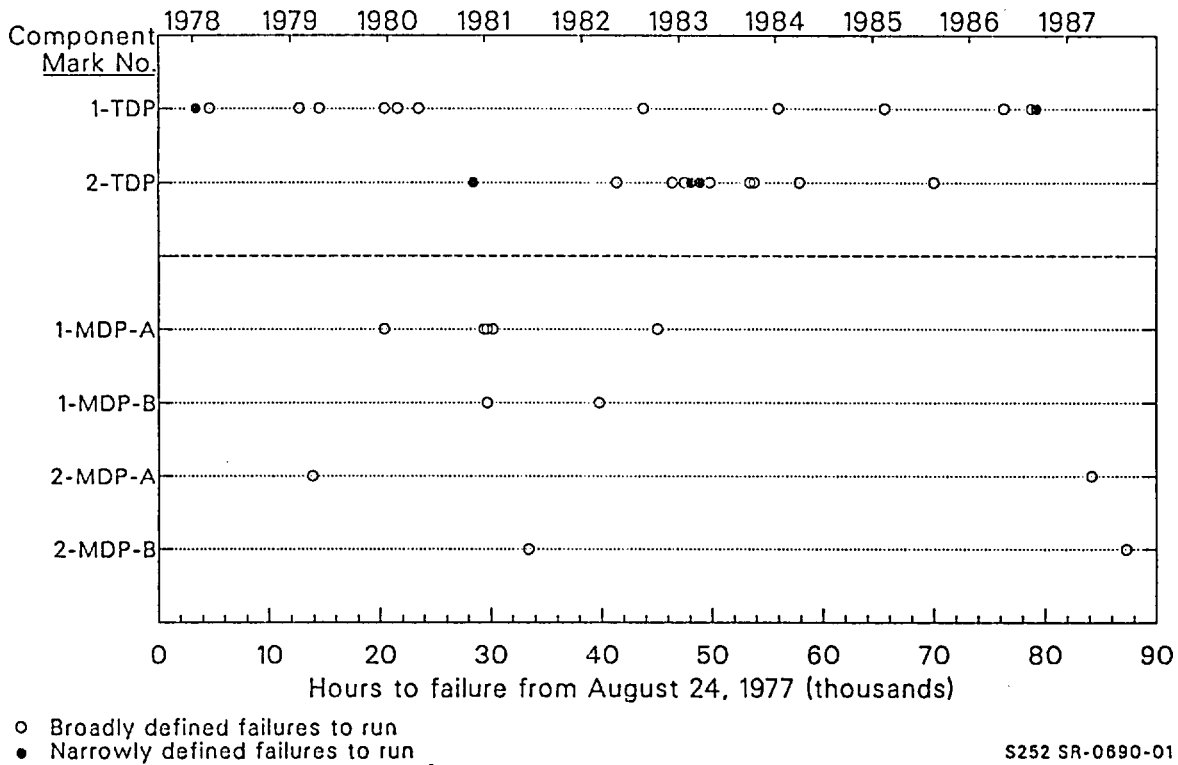
In summary, based on maintenance records and the logical application of the important failure modes modeled in the PRA, 118 broadly defined and 35 narrowly defined failures were determined to have occurred in the AFW system in the 10-year period. These failures were statistically analyzed to determine if the rate of failure was increasing with time.

Finally, note that the "return-to-service-date" was used as a surrogate for the actual date a failure occurred because actual dates were not available for this period of operation. In general, the return-to-service-date was within one month of the actual failure date.

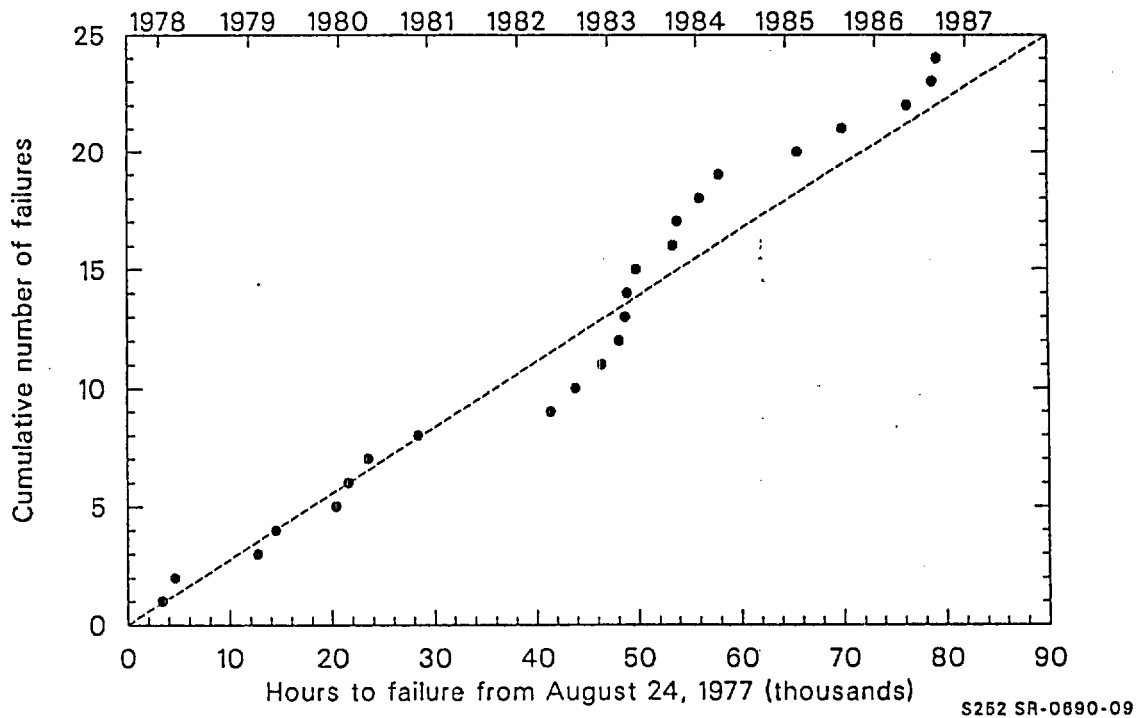
## 4.5 Failure Timelines and Cumulative Failure Curves

The timelines and cumulative failure curves corresponding to the descriptions in the previous sections appear as Figures 4-3 through 4-19. A time plot is simply a graphical tabulation of the failure times. A cumulative failure curve is a plot of the cumulative numbers of failures as a function of time. This plot will be an approximately straight line for a constant failure rate process (see Section 5.3.2). A general observation for the behavior of the data can be derived from the timelines and cumulative failure plots. If the failures are largely concentrated in later years and the cumulative failure curve is therefore concave upward, then there is a general indication of increasing failure rate, suggesting aging of the components. If the failures are largely concentrated in the earlier years and the cumulative failure curve is therefore concave downward, then there is a general indication of decreasing failure rate.

# Component Failure Data



**Figure 4-3.** Failure to run timeline for steam- and motor-driven pumps.



**Figure 4-4.** Cumulative failure plot for steam-driven pumps, broadly defined failures to run.

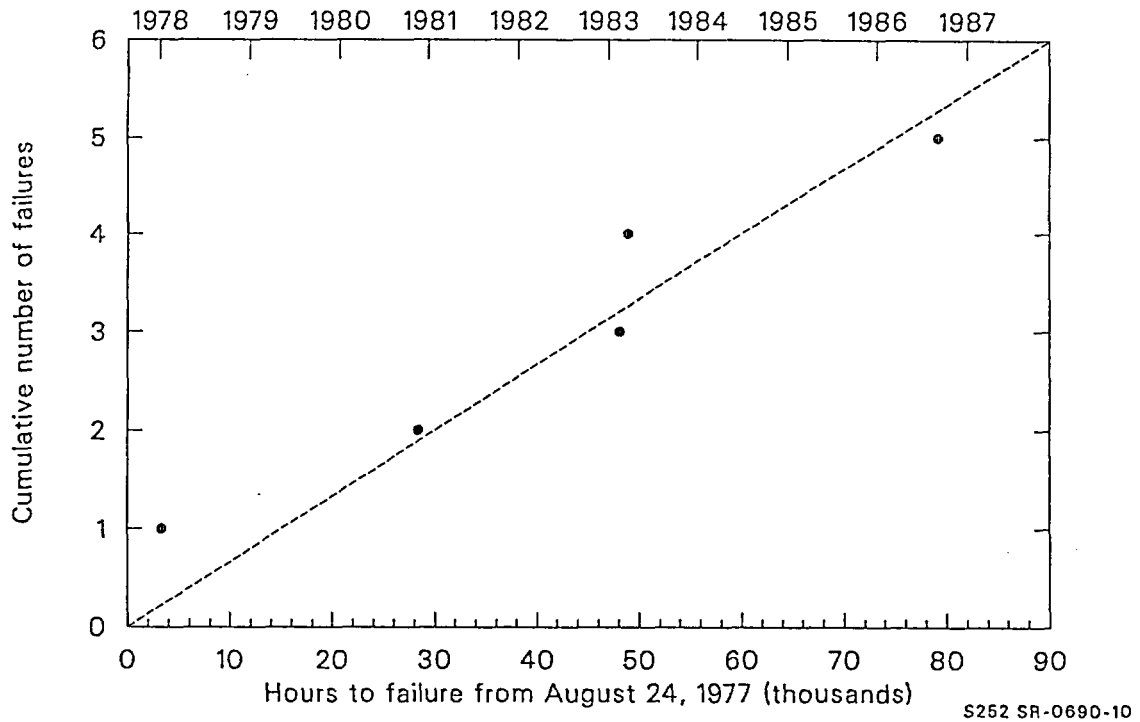


Figure 4-5. Cumulative failure plot for steam-driven pumps, narrowly defined failures to run.

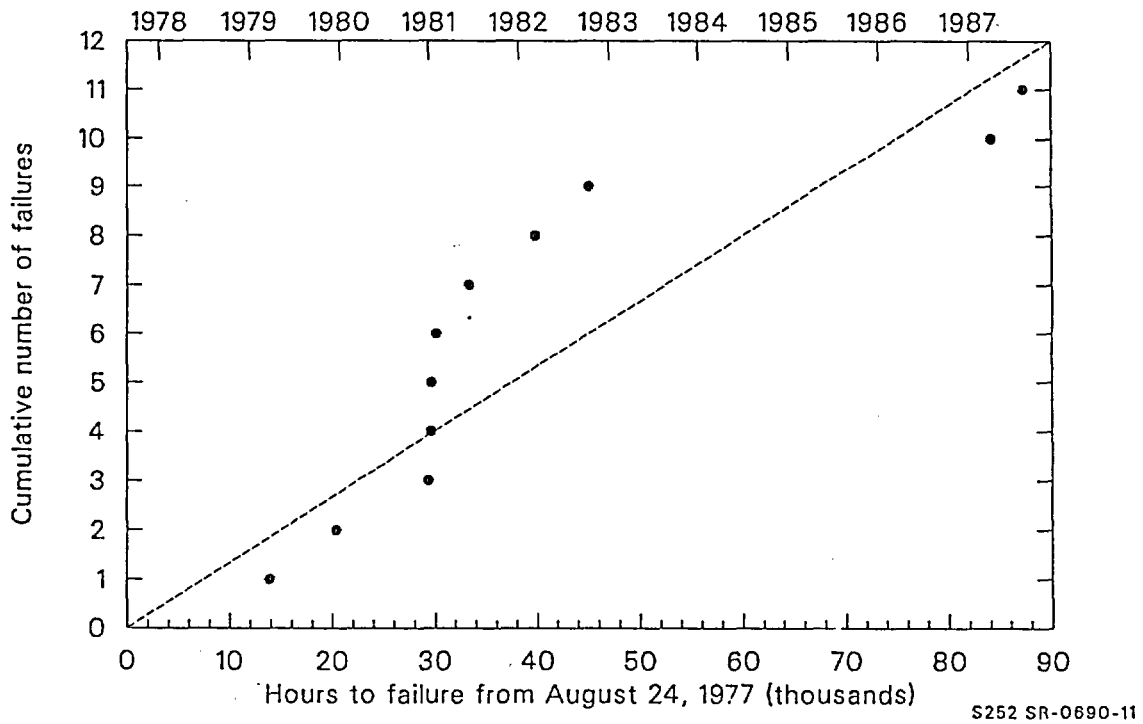
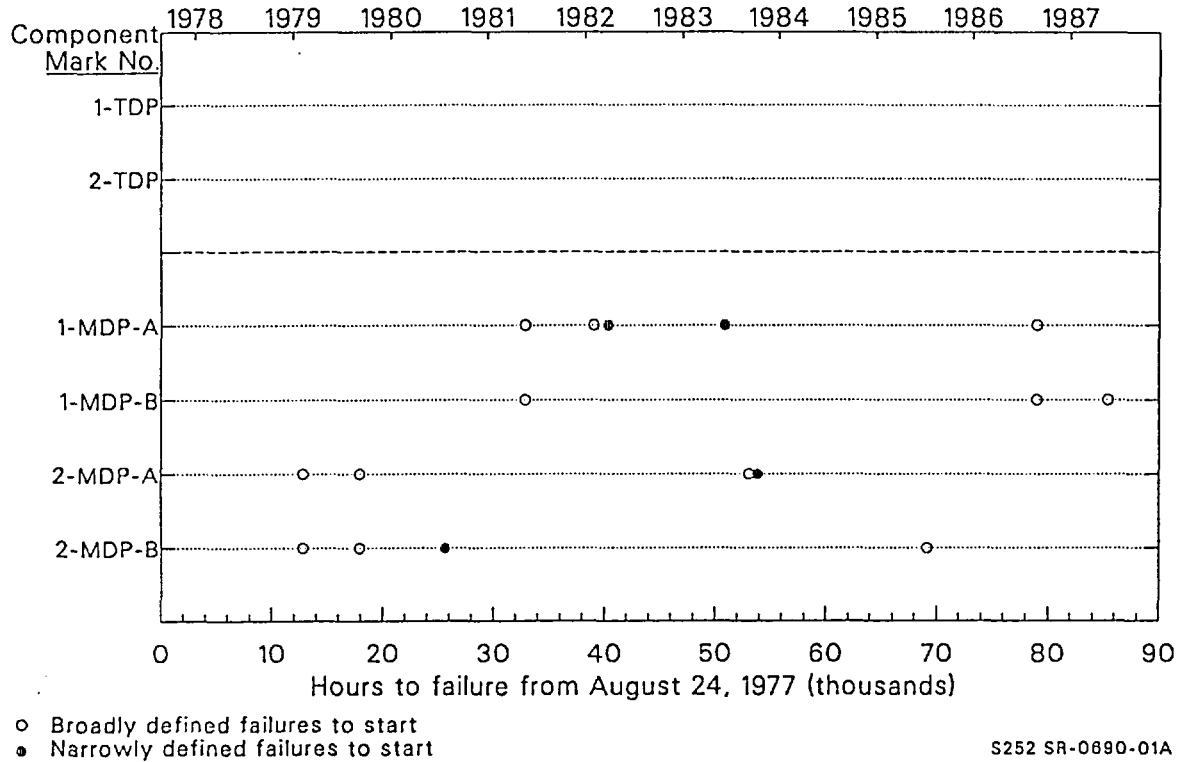
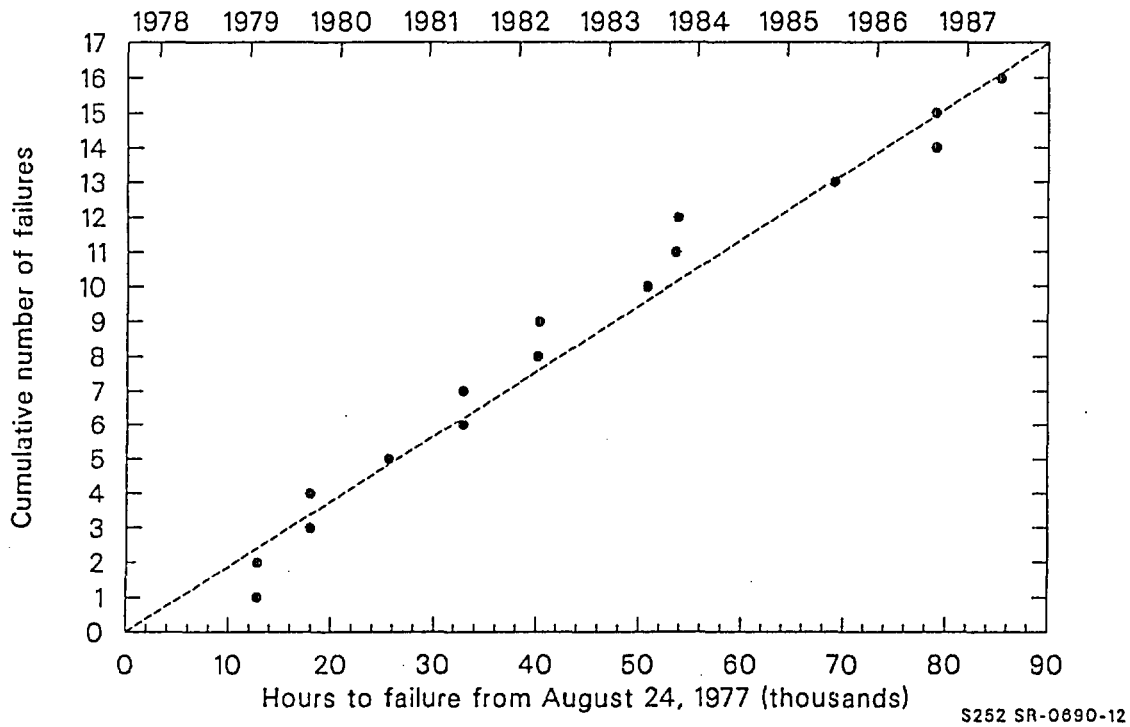


Figure 4-6. Cumulative failure plot for motor-driven pumps, broadly defined failures to run.

# Component Failure Data



**Figure 4-7.** Failure to start timeline for steam- and motor-driven pumps.



**Figure 4-8.** Cumulative failure plot for motor-driven pumps, broadly defined failures to start.

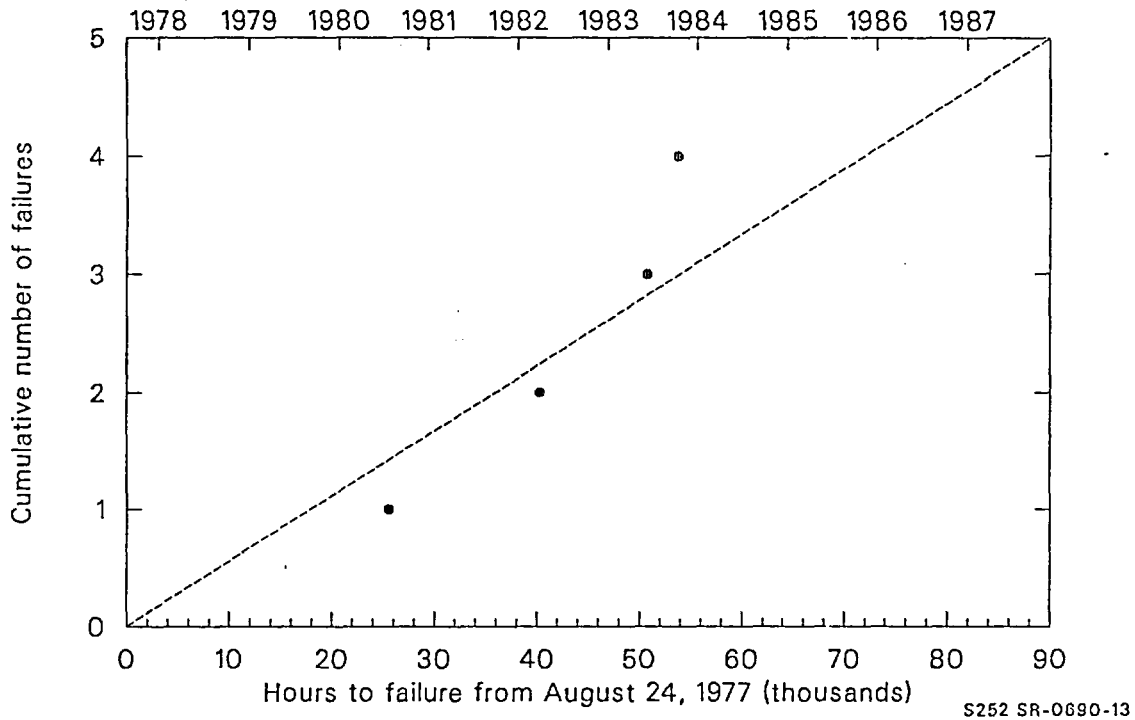


Figure 4-9. Cumulative failure plot for motor-driven pumps, narrowly defined failures to start.

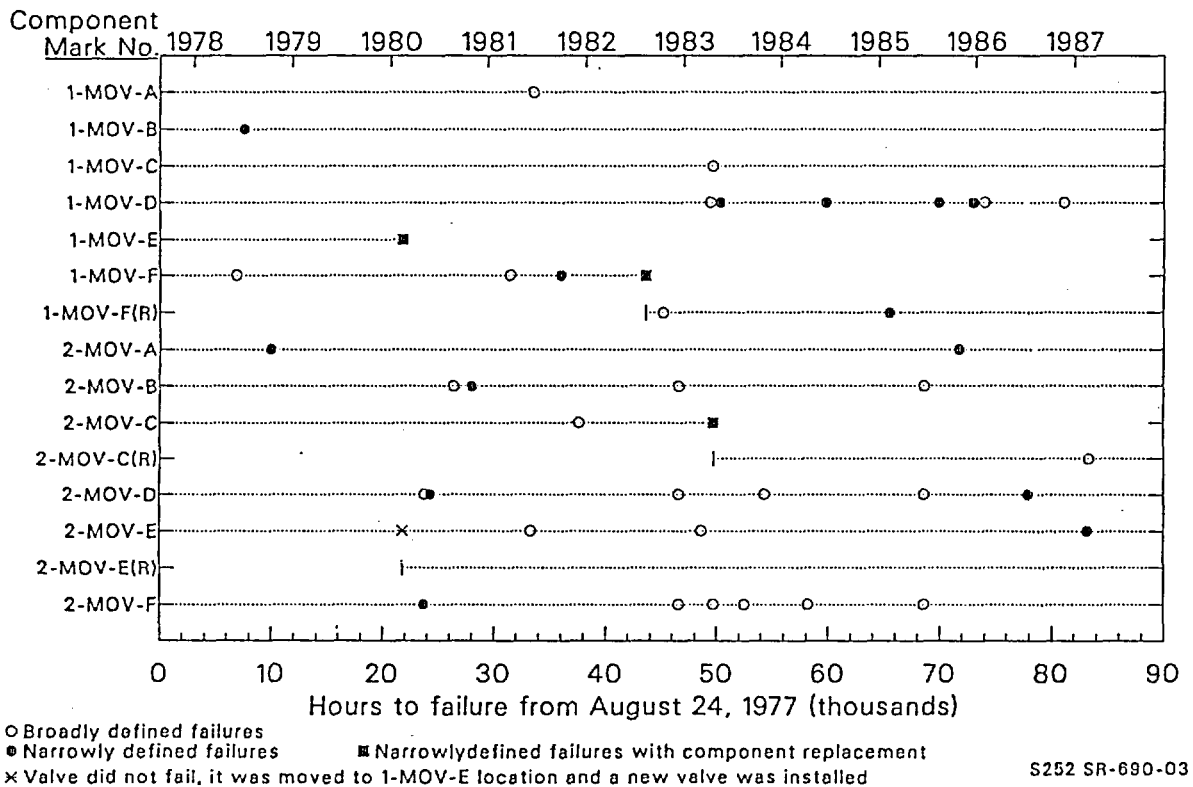
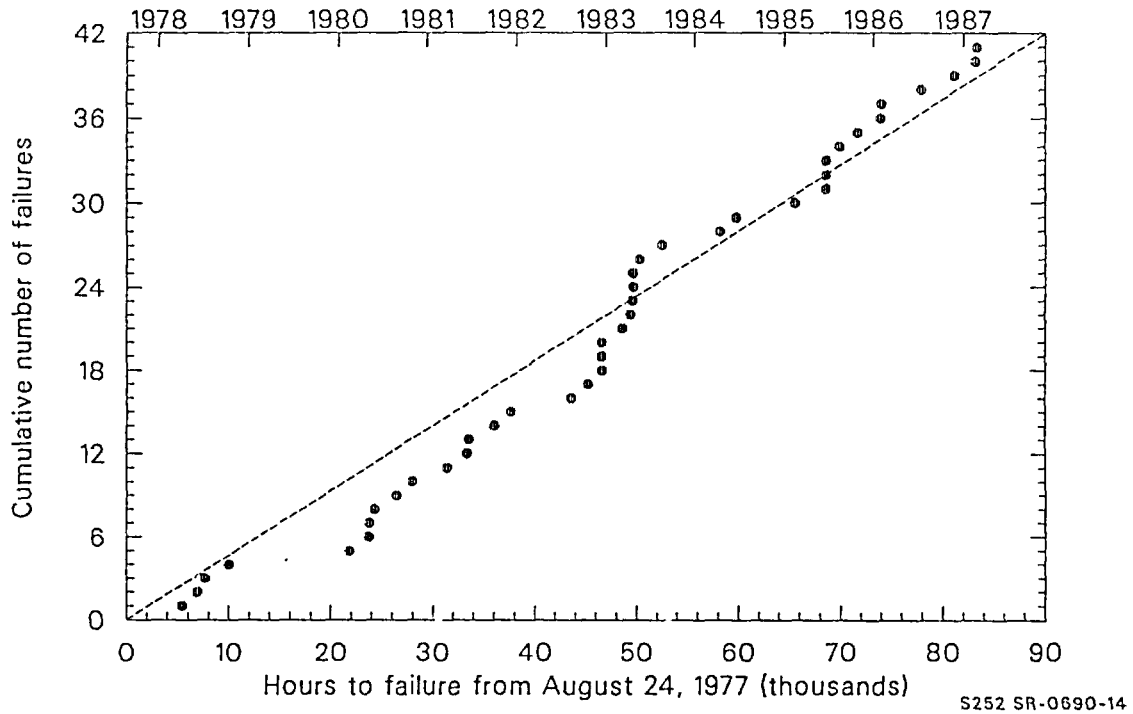
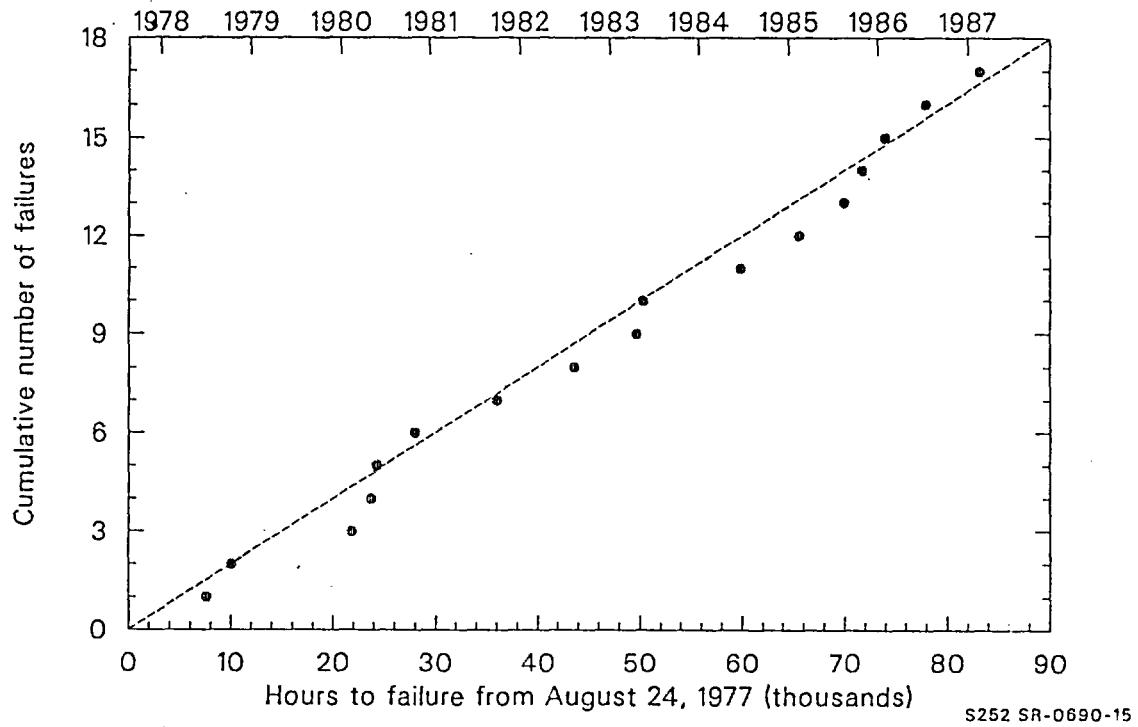


Figure 4-10. Plugging failure timeline for 3-in. MOVs (feed header isolation valves).

## Component Failure Data



**Figure 4-11.** Cumulative failure plot for 3-in. MOVs (feed header isolation valves), broadly defined plugging failures.



**Figure 4-12.** Cumulative failure plot for 3-in. MOVs (feed header isolation valves), narrowly defined plugging failures.

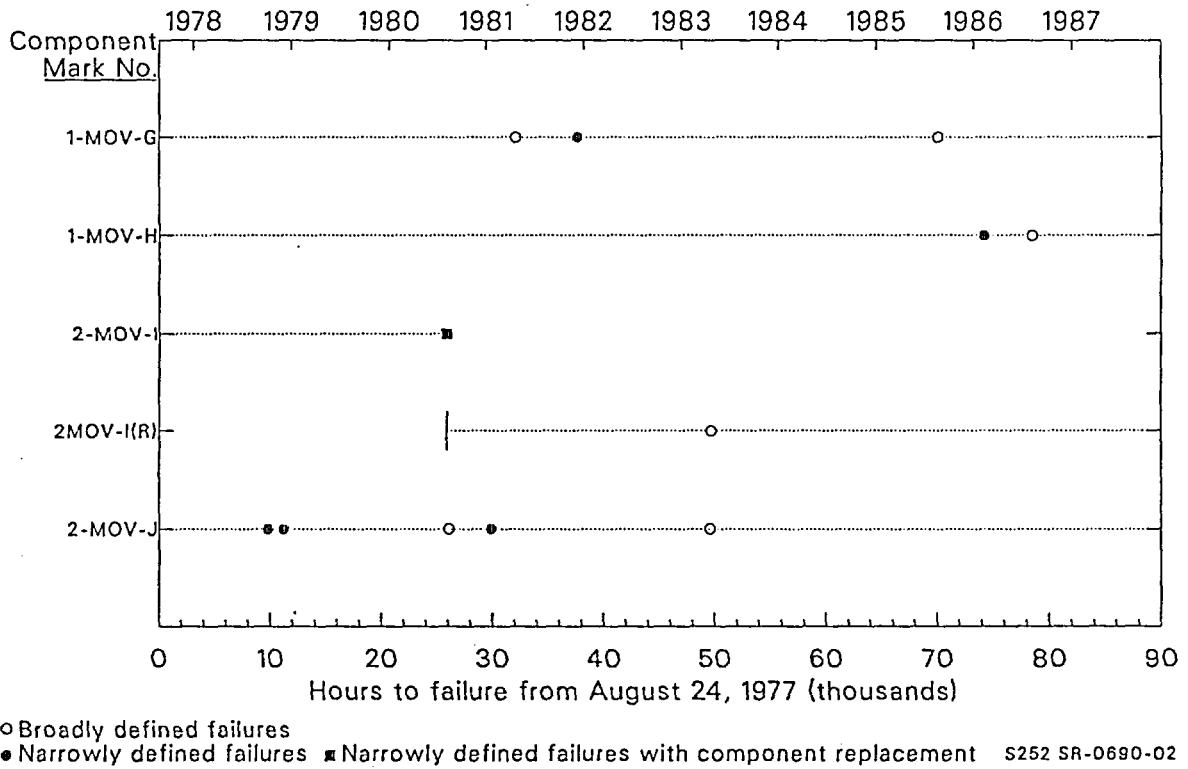


Figure 4-13. Failure to stay closed timeline for 6-in. MOVs (cross-connect valves).

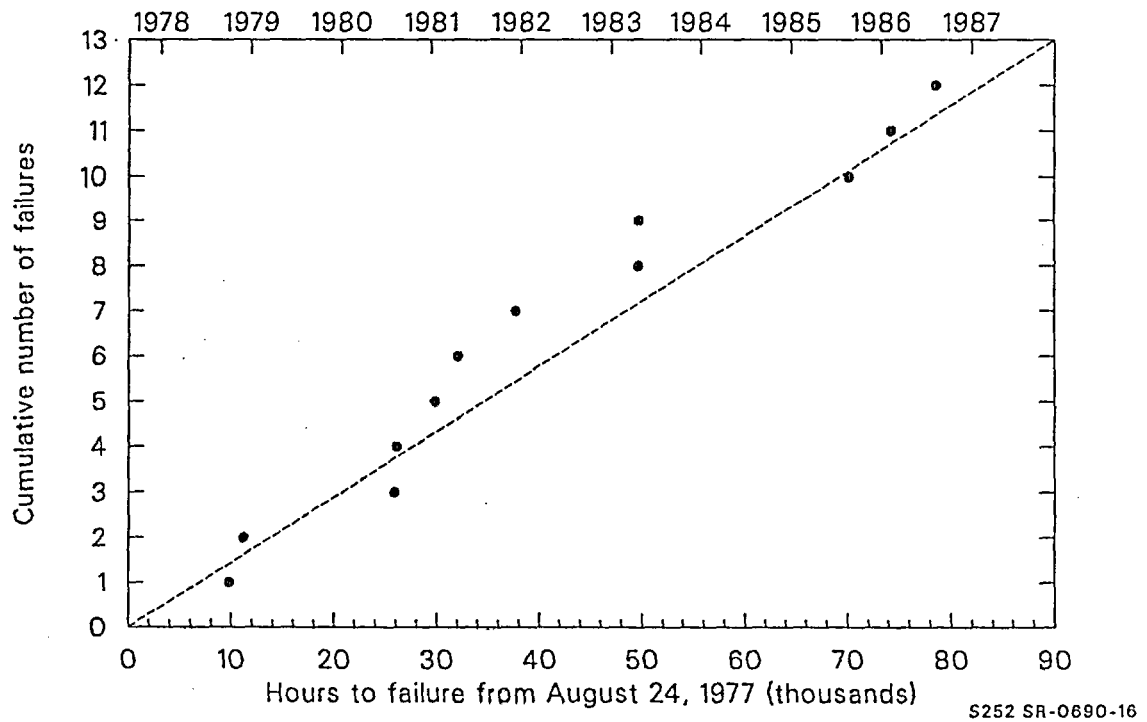
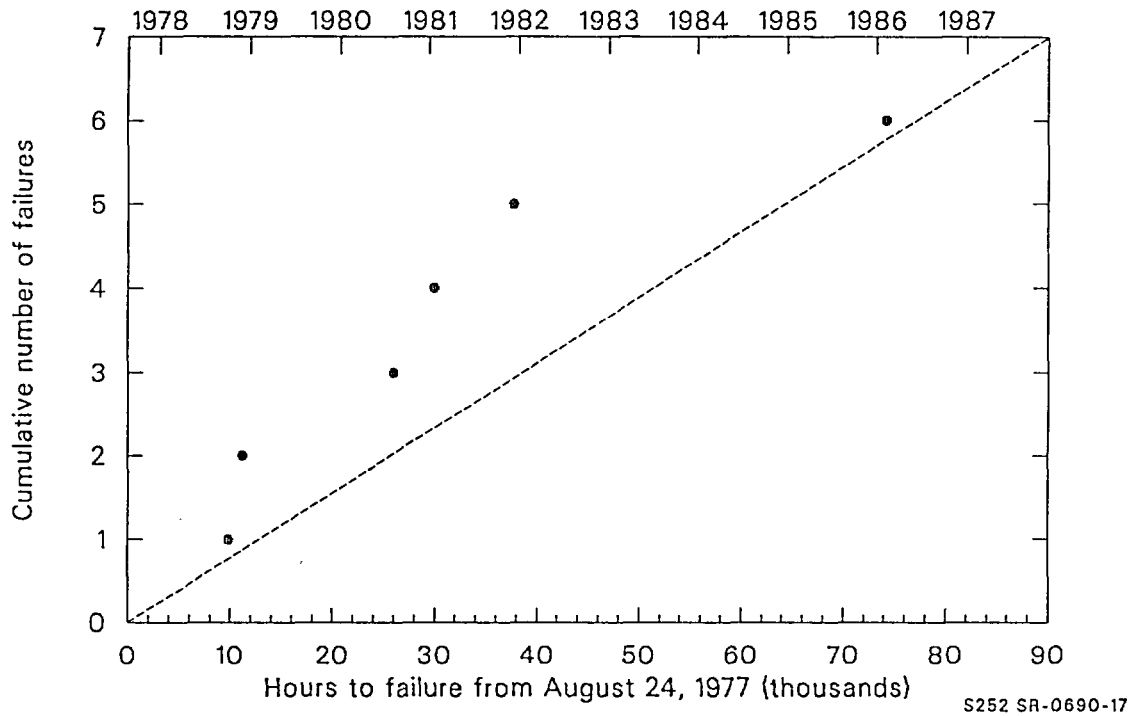


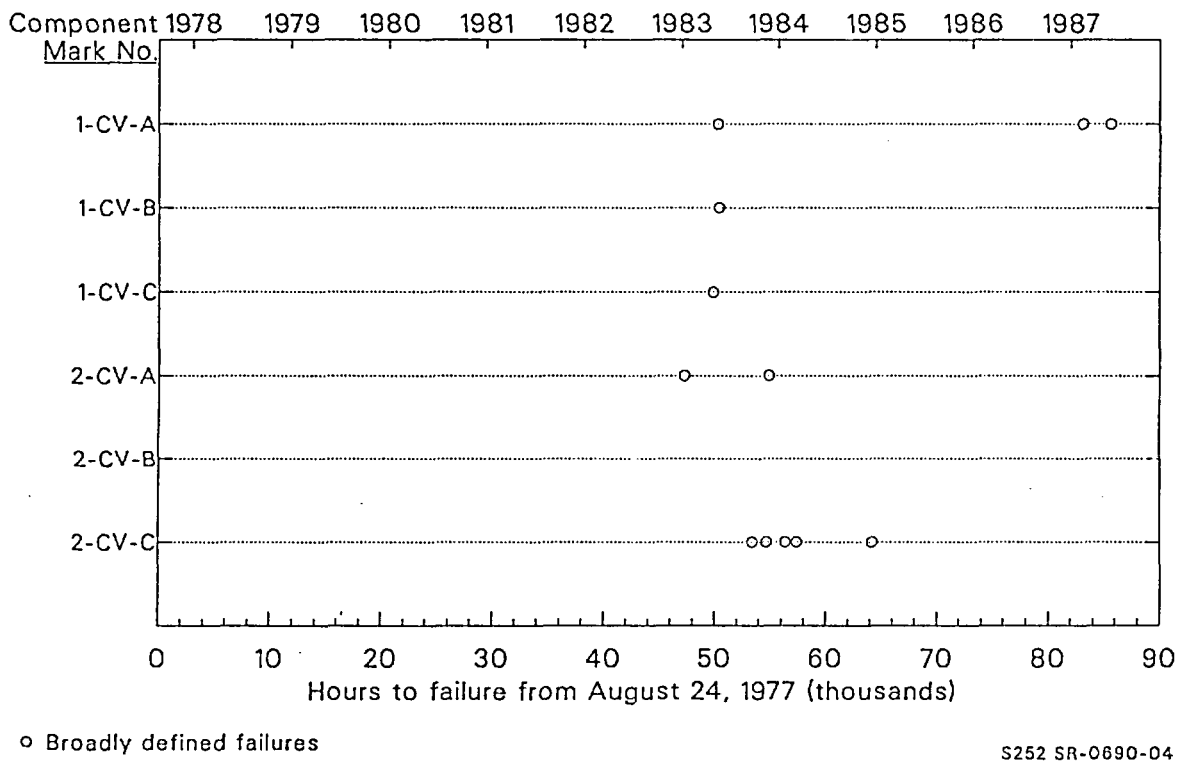
Figure 4-14. Cumulative failure plot for 6-in. MOVs (cross-connect valves), broadly defined failures to stay closed.



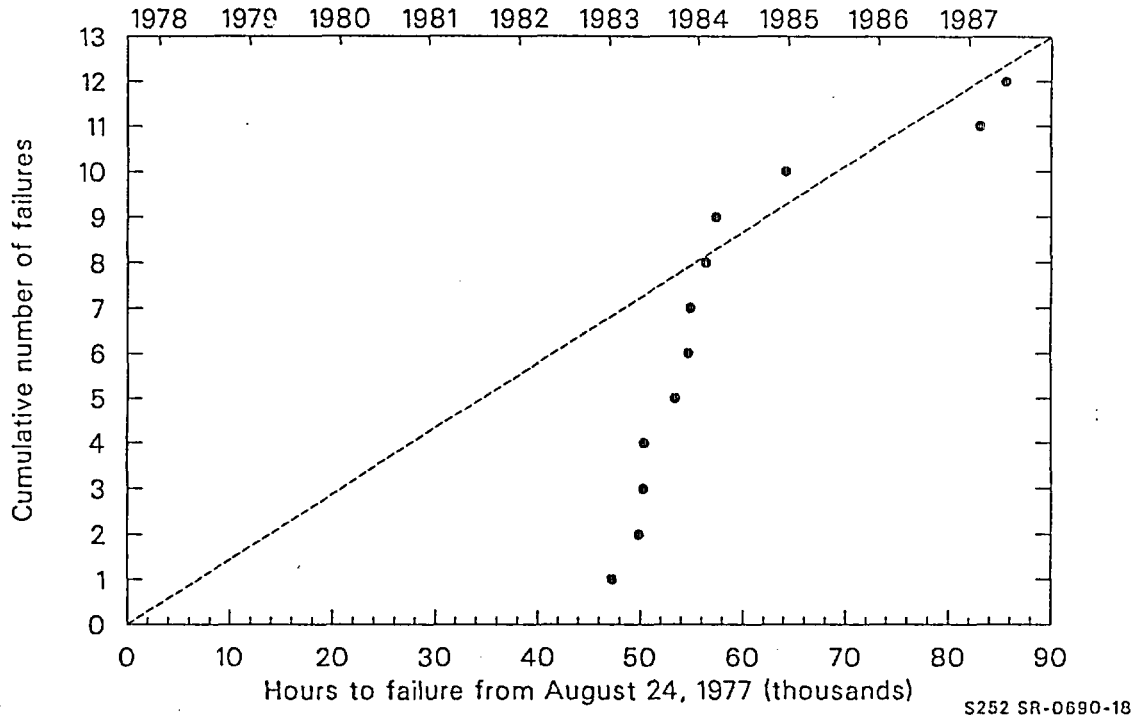
## Component Failure Data



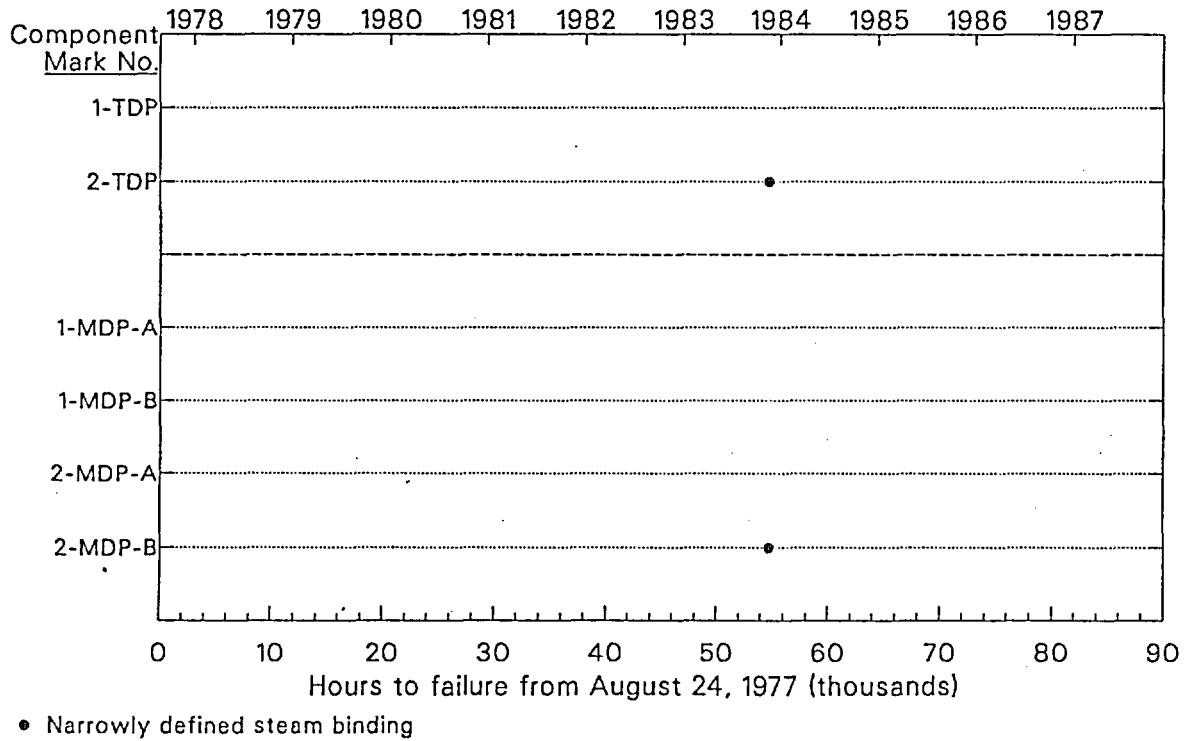
**Figure 4-15.** Cumulative failure plot for 6-in. MOVs (cross-connect valves), narrowly defined failures to stay closed.



**Figure 4-16.** Backflow failure timeline for pump discharge check valves. Following discussion with personnel from the power station, these events were all reinterpreted as non-failures. See Section 6.2.3.

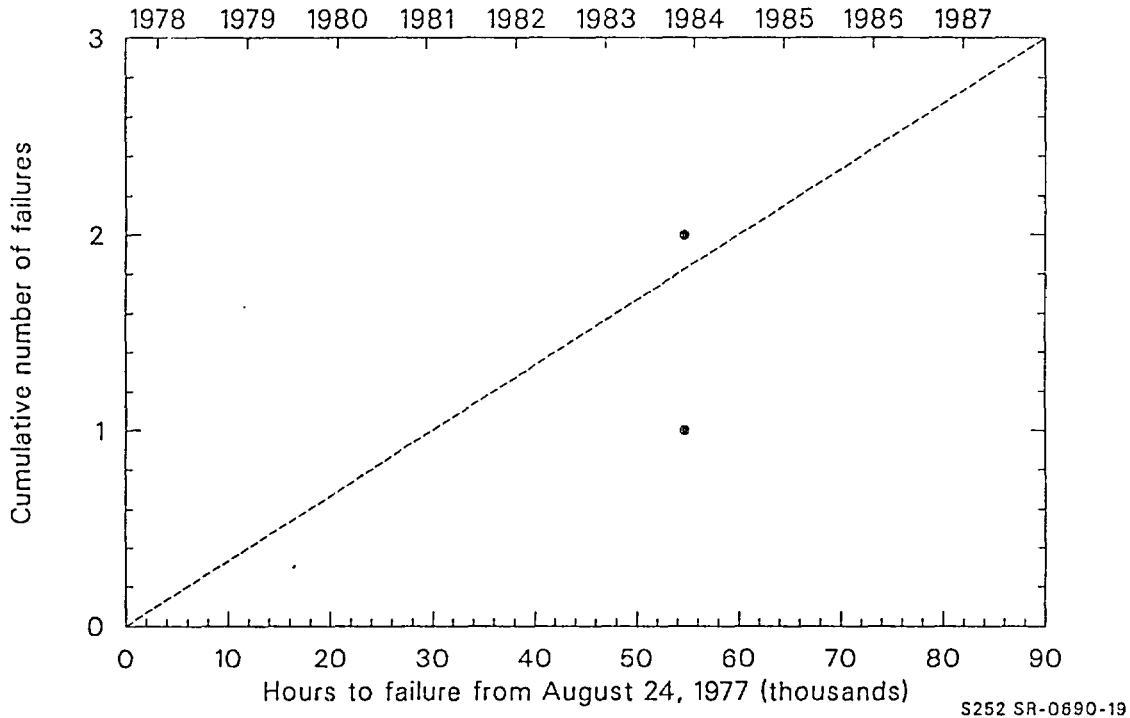


**Figure 4-17.** Cumulative failure plot for pump discharge check valves, broadly defined backflow leakage failures. Following discussion with personnel from the power station, these events were all reinterpreted as non-failures. See Section 6.2.3.



**Figure 4-18.** Steam binding failure timeline for the steam- and motor-driven pumps.

## Component Failure Data



**Figure 4-19.** Cumulative failure plot for the steam- and motor-driven pumps, broadly and narrowly defined steam binding failures.

One overall observation about this graphical display of the data is that the plots are basically uninformative in the cases with few failure occurrences. In addition, it is difficult to test any component data pooling assumptions with this graphical display. The statistical methods discussed in Section 5 are specifically designed to analyze such sparse data and to test the homogeneity of the (aggregated) sample of component failures.

Many of the cumulative plots, such as Figure 4-4, show little departure from a straight line, indicating that the failure rate appears to be roughly constant. This is consistent with the corresponding timelines, such as shown in the top portion of Figure 4-3, where the failure times appear to be uniformly scattered over time. Other

cumulative plots, (Figures 4-6, 4-8, and 4-17) show clustering of the failures. In these cases, the timelines can help clarify the kind of clustering that occurred. For example, Figure 4-7 shows that the failures tended either to occur in pairs or to be repaired in pairs. Figure 4-16 shows that three valves were repaired for leakage almost simultaneously, while a different valve had recurrent repairs. The clustering in Figures 4-16 and 4-17 was strong enough to motivate questioning of the personnel at the power station, which led to a reinterpretation of the data, as described in Section 6.2.3. There are no obvious cases of increasing failure rate, although Figures 4-6 and 4-15 may show decreasing failure rates. Sections 5 and 6 present analysis approaches that are more sensitive and less subjective than simple inspection of these figures.

## 5. STATISTICAL METHODS FOR ANALYZING TIME-DEPENDENT FAILURES

The usual assumption in PRAs is that each component has a constant failure rate  $\lambda$ . This leads to familiar formulas such as  $1 - e^{-\lambda t}$  for the probability of failure by time  $t$ , and  $\lambda \Delta t$  for the approximate probability of failure within a short time  $\Delta t$ . The data are said to be generated by a homogeneous Poisson process because the number of failures occurring in any time  $t$  is a Poisson random variable with parameter  $\lambda(t)$ . One feature of this process is that the component does not age. That is, the probability of failure in a short interval of length  $\Delta t$ , assuming that the component is operable immediately before the start of the time interval, remains the same  $\lambda \Delta t$ , whether the component is new or old. In an investigation of aging, therefore, more complicated models must be introduced, and the familiar formulas must be modified.

The development of such models and associated techniques of data analysis form the subject of this section. For this development, we step away from the PWR context of the previous sections, and consider the statistical methods themselves. These methods are the basis for the analysis in Sections 6 and 7. The topics are outlined here without proofs or many details. Details about the theory, including the necessary proofs, are given in Appendix A. Details about the numerical methods for implementing the theory are given by Atwood (1990). The most recent presentation of the statistical methods is Atwood (1992). They are illustrated here by both real and hypothetical examples. Unless indicated otherwise, all the figures are based on the data for plugging of 3-in. motor-operated valves (MOVs), failure mode AFW-MOV-PG with the broad definition of failure, and on the exponential failure rate model defined below.

### 5.1 Aging Models

The approaches used for inference about aging assume that the failures of a component follow a time-dependent Poisson process. That is,

- The occurrence of a failure in any time interval is independent of the presence or absence of failures in other non-overlapping time intervals.
- The probability of a failure in a short period  $(t, t + \Delta t)$  asymptotically approaches  $\lambda(t)\Delta t$  as  $\Delta t \rightarrow 0$ .
- The probability of more than one failure in a short period  $(t, t + \Delta t)$  becomes negligible compared to the probability of one failure as  $\Delta t \rightarrow 0$ .

Therefore, the failure process has failure rate  $\lambda(t)$ . If  $\lambda(t)$  is an increasing function of  $t$ , failures tend to become more frequent as time goes on. A statistical approach can be used to decide whether  $\lambda(t)$  is increasing.

When applying this model to investigate aging,  $t$  represents the age of a component. It is assumed that the form of  $\lambda(t)$  is the same for all similar components, depending only on the ages of the components, not on the portion of the plant's history when the components were in service. This in turn rests on an assumption that we make explicit: The environments of the components (ambient conditions, maintenance and operation practices, and any degrading conditions) are constant throughout the life of the plant.

The general form assumed for  $\lambda$  is

$$\lambda(t) = \lambda_o h(t; \beta).$$

The three specific models considered in this report are

$$\lambda(t) = \lambda_o e^{\beta t} \quad (\text{exponential failure rate})$$

$$\lambda(t) = \lambda_o (t/t_o)^\beta \quad (\text{Weibull failure rate})$$

$$\lambda(t) = \lambda_o (1 + \beta t) \quad (\text{linear failure rate})$$

In each model,  $\lambda_o$  is a normalizing constant, with units 1/time, and  $h(t; \beta)$  is a dimensionless

function of time  $t$  and a parameter  $\beta$ . The value of  $\beta$  determines the shape of the failure rate function. The failure rate is increasing if  $\beta > 0$ ; it is constant if  $\beta = 0$ ; and it is decreasing if  $\beta < 0$ .

For the exponential and linear failure rate models,  $\lambda_0$  is the value of the failure rate at time  $t = 0$ . In these two models,  $\beta$  has units 1/time, so that the product  $\beta t$  is dimensionless. For the Weibull model,  $t_0$  is some normalizing time, and  $\beta$  is dimensionless. The choice of  $t_0$  is arbitrary, but a value somewhere in the range of observed values of  $t$  is convenient. Then  $\lambda_0$  is the value of the failure rate at time  $t_0$ .

The analysis considers each of the three models. There are no theoretical reasons for postulating one over the others. The data used in this study, however, give much less satisfactory results when the linear model is used than when the exponential or Weibull model is used. With the linear failure rate model, it is not uncommon for the MLE for  $\beta$  to be infinite, for the uncertainties to be very large, or for the normal approximation to be unusable. In the best-behaved examples, the three models give similar estimated failure rates in the region of the observed failures. Therefore, all three models were tried initially, but full results are reported only for the exponential and Weibull models. The results using these two models are similar and would diverge only if an analyst tried to extrapolate far beyond the time period of the observations.

Each of the three models has its own special characteristics. Under the exponential model with  $\beta > 0$ , the failure rate doubles every  $\log(2)/\beta$  hours. Under the linear model the failure rate doubles from its initial value in  $1/\beta$  hours, doubles again in the next  $2/\beta$  hours, and so forth. Under the Weibull model, the failure rate at time 0 either is zero (if  $\beta > 0$ ) or is undefined (if  $\beta \leq 0$ ). Therefore, it is not meaningful to speak of the failure rate doubling from its initial value. However, the failure rate doubles between times  $t_1$  and  $t_2$  whenever  $(t_2/t_1) = 2^{1/\beta}$ . As has been

mentioned, the linear failure rate model is the least tractable of the three models. This may be surprising, but follows from the fact that both the mathematical formulas and the calculated numbers in applications are best behaved when  $\log \lambda(t)$  is linear in  $\beta$ . This log-linearity is present for the exponential and Weibull failure rate models, but not for the linear failure rate model. See Appendix A for more detail on all three models.

Some other references for the use of the models are as follows. Cox and Lewis (1966) give a detailed treatment of the exponential failure rate model when there is just one component. The Weibull model has been explored by Crow (1974, 1982 and works cited there) and Donelson (1975) and is reviewed by Engelhardt (1988). The Crow and Donelson papers derive explicit formulas for the MLEs when all the components are observed from their time of installation. These formulas are also mentioned in Appendix A, but are not useful for the data of this report because very few of the components are observed from their time of installation. Most papers on the Weibull model use  $\beta-1$  in the exponent, a slightly different parameterization from the one given in this section. The parameterization with  $\beta$  in the exponent is used here because it allows the same interpretation of  $\beta$  in all three models, with  $\beta = 0$  corresponding to a constant failure rate. The linear model has been less widely used in the literature, although it is considered by Salvia (1980) and Vesely (1987).

It was assumed that each component's failure rate is of the same form (exponential, Weibull, or linear), and that the value of  $\beta$  is the same for all the components. It was not assumed initially that the components have the same value of  $\lambda_0$ , although examination of the data for this report always led to the conclusion that the values of  $\lambda_0$  may be treated as all the same.

## 5.2 Assumptions Regarding Failure Data

Failure data for a component can arise in the following ways:

- A random number of failure occurrences in a fixed observation period (time-censored data)
- A fixed number of failure occurrences in a random observation period (failure-censored data)
- More complicated ways.

Time-censored data arise if the component is watched or plant records are examined for a fixed time period. During that time, a random number of failures occur. At each failure, the component is repaired (made as good as it was just before the failure) and returned to service.

Failure-censored data arise if the component is repaired until a predetermined number of failures have occurred. At that time the component is removed from service and replaced by a new component. Both of these types of failure data result in tractable formulas for statistical inference.

In reality, the decision to repair or replace a component is based on a number of considerations, such as the availability and cost of replacement components, the severity of the particular failure mode (including the difficulty, cost, and potential safety hazards of repair), any recent history of failures, and other similar factors. These considerations are difficult to express in a simple mathematical model. Therefore, the data analysis considered here assumes that the data for a component are generated in one of two simple ways: if the final failure time is less than the observation time, the data for the component are considered time-censored; whereas, if the final failure time equals the observation time because the component was replaced, then the data for the component are considered failure-censored.

It is never required that components be observed starting from the moment of installation, only that each component be observed starting at some known time, which may or may not coincide with the component's installation.

Distinct components are assumed to fail independently of each other.

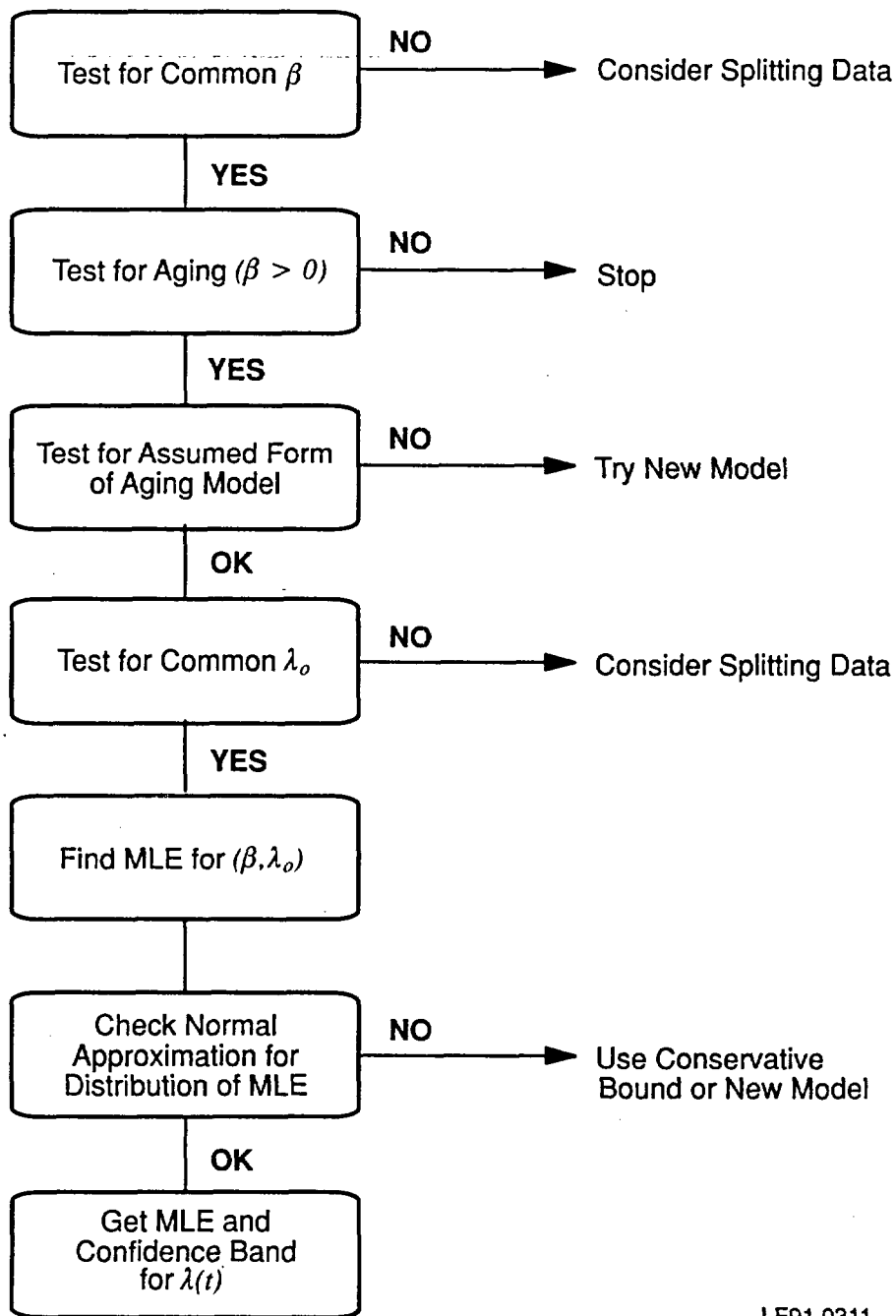
### 5.3 Inference Methods

The approach shown in Figure 5-1 is outlined here. (Figure 5-1 expands a portion of Figure 2-2.) First, investigate the assumption that all the components have the same value of  $\beta$ . If the data show no strong evidence against this assumption, accept that portion of the model. Then test whether  $\beta = 0$ , that is, whether the failure rate is constant. If the data show evidence (statistically significant at the selected level) of a non-constant failure rate, continue with the analysis; otherwise, treat the failure rate as constant and stop the analysis of this set of components.

When the failure rate appears to be non-constant, investigate the assumption that it is of the assumed form (exponential, Weibull, or linear). If the data seem consistent with the assumed form, investigate the assumption that all the components have the same value of  $\lambda_0$ . If the data show no strong evidence against this assumption, accept that all the components have a common  $\lambda_0$  as well as a common  $\beta$ . Find the MLEs of  $\beta$  and  $\lambda_0$  and obtain the corresponding MLE of  $\lambda(t)$  at any  $t$ . Now investigate whether the joint MLE of the two parameters ( $\beta, \log \lambda_0$ ) may be treated as having a normal distribution. If so, the approximate normality of the MLE yields an approximate confidence interval for  $\lambda(t)$ .

The first four steps in Figure 5-1 involve statistical testing, that is, looking for evidence against the default assumptions. As in all testing situations, when the data set is small the tests have low power. That is, when there are few failures, there will be no strong evidence of differences in  $\beta$  between the components, and no strong evidence of aging, or of lack of fit to the model, or of differences in  $\lambda_0$ . Thus, small data sets typically give no reason to discard the usual PRA model of a constant failure rate that is the same for all similar components.

Statistical inference is generally based on the likelihood function, which depends on the data



LF91 0311

Figure 5-1. Approach for statistical analysis of one data set.

and on the parameter(s). Inference for  $\beta$  is of primary interest in a study of aging, because it is  $\beta$  that determines whether the failure rate is increasing. It is shown in Appendix A that the conditional likelihood can be used to perform inference for  $\beta$ , without assuming that the components necessarily have a common value of  $\lambda_o$ , and without estimating either the single  $\lambda_o$  or all the  $\lambda_{os}$ . The conditional likelihood is defined as the probability density of the non-replacement failure times, given the failure counts for time-censored components and given the final failure times for failure-censored components. As shown in Appendix A, if the components are not assumed necessarily to have the same value of  $\lambda_o$ , and if the components are all time-censored, there are strong theoretical grounds for using the conditional likelihood. In other cases, some information about  $\beta$  is lost by using the conditional likelihood.

Therefore, the first exploratory analysis used to verify assumptions of the model is based on the conditional likelihood. In this way the first four steps in Figure 5-1 are carried out without assuming that there is a common  $\lambda_o$ . Later, when both parameters must be estimated simultaneously to produce an estimate of the failure rate  $\lambda(t)$  at various times  $t$ , the full likelihood is used.

All the computations were carried out by the computer code PHAZE, documented by Atwood (1990). The portions of the approach just outlined are described in more detail in the next sections.

### 5.3.1 Inference for $\beta$ .

**Estimation and Confidence Intervals for  $\beta$ .** Appendix A gives formulas for the conditional likelihood of the non-replacement failure times, conditional on the failure counts or the final replacement failure times, whichever is random. This conditional likelihood depends only on  $\beta$ , not on the (possibly different) values of  $\lambda_o$  for the components. Therefore,  $\beta$  can be estimated while  $\lambda_o$  or the  $\lambda_{os}$  are ignored. Based on  $L(\beta)$ , the logarithm of the conditional likelihood, the MLE  $\hat{\beta}$  is the value satisfying

$$(d/d\beta)L(\beta) = 0,$$

and can be found by numerical iteration.

Let  $\beta$  be the true value governing the failure rate. Then  $(d/d\beta)L(\beta)$  has expectation 0 and variance denoted by  $I(\beta)$ , calculated by formulas given in Appendix A. The distribution of  $(d/d\beta)L(\beta)$  is asymptotically normal by the Central Limit Theorem. Therefore, an approximate confidence interval for  $\beta$  is the set of all  $\beta_o$  such that

$$(d/d\beta)L(\beta_o)/[I(\beta_o)]^{1/2} \quad (5-1)$$

lies in the interval  $(-c, c)$ , where  $c$  is the appropriate number from a normal table; for example,  $c = 1.645$  yields an approximate 90% confidence interval.

When the linear failure rate model is used with a small data set, it is not uncommon for the MLE, or at least for one end of the confidence interval, to be infinite. This is one reason for preferring the exponential or Weibull model.

**Component Comparisons for  $\beta$ .** Consider the possibility that the different components have different values of  $\beta$ . Let  $\beta_j$  denote the actual value of  $\beta$  corresponding to the  $j$ th component. It is estimated by using only the data from one component.

A visual comparison of the components can be made by plotting confidence intervals for the various  $\beta_j$  values, each interval based only on data from a single component. Two examples are shown in Figures 5-2 and 5-3. If the intervals largely overlap, as they do in Figure 5-2, then the data are consistent with the assumption that the  $\beta_j$  values are all equal.

If one or more confidence intervals are clearly shifted away from the others, as for components 8 and 9 in Figure 5-3, then those few components are evidently aging at a different rate from the others.



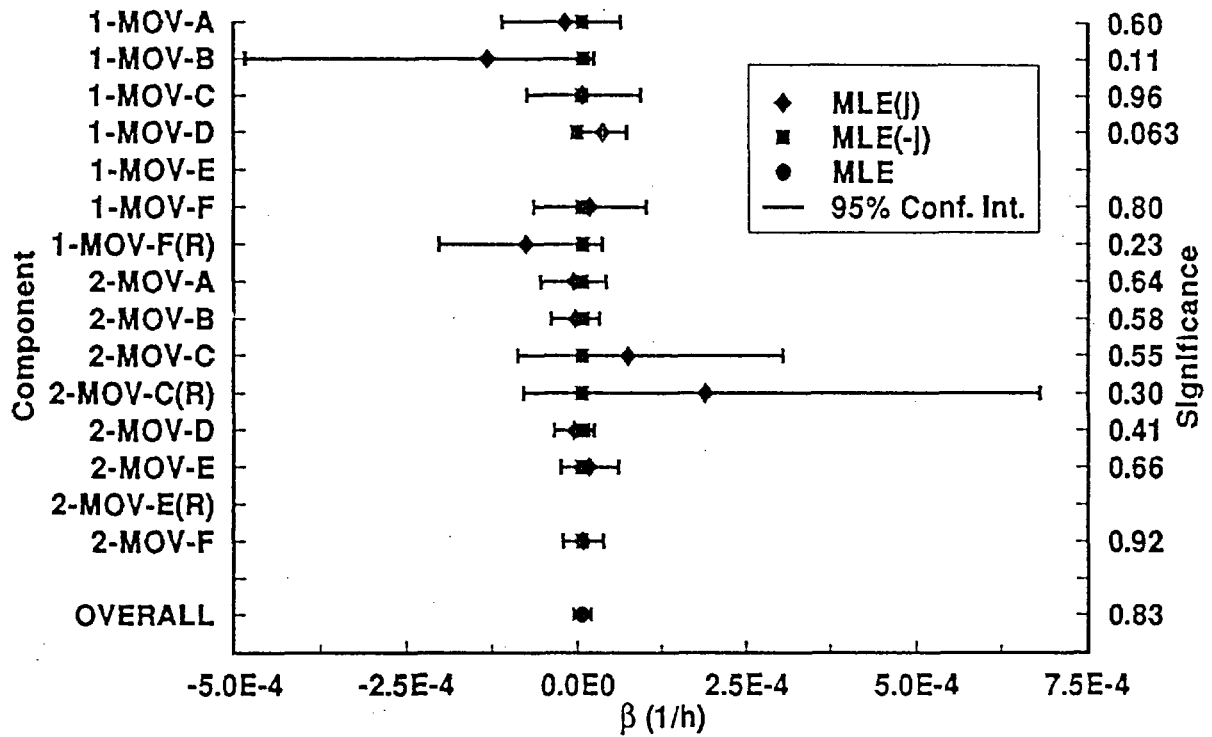


Figure 5-2. Component comparisons for  $\beta$ .

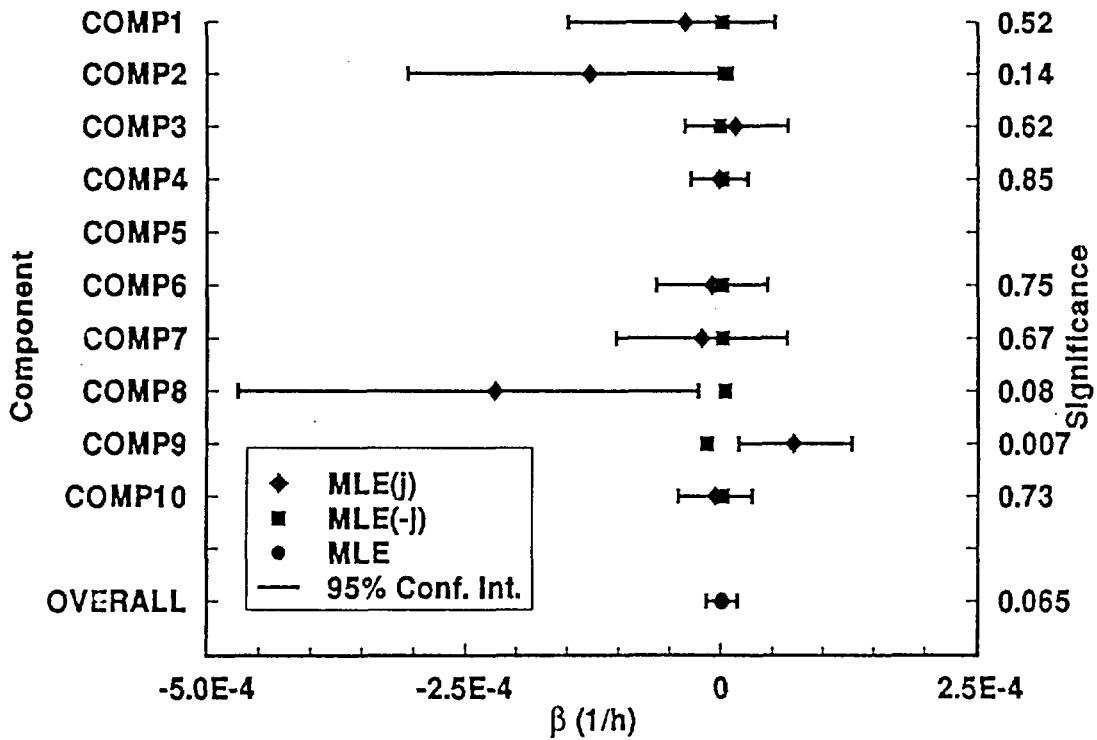


Figure 5-3. Component comparisons for  $\beta$ , based on hypothetical data.

These anomalous components are called "outliers." At the end of this section we mention that engineering judgment must play a decisive role in the subsequent treatment of outliers. Of course, no confidence interval for  $\beta_j$  can be calculated if the component has no observed failures or if the only observed failure resulted in replacement of the component. This is why some of the components have no associated interval in Figures 5-2 and 5-3.

A more quantitative comparison can be performed by considering

$$\hat{\beta}_j - \hat{\beta}_{-j}.$$

Here  $\hat{\beta}_j$  is the MLE of  $\beta_j$ , based on the data from only the  $j$ th component. The quantity  $\hat{\beta}_{-j}$  is the overall MLE of  $\beta$ , assuming that the components have a common  $\beta$  and using all the data *except* the data from component  $j$ . Because the estimators  $\hat{\beta}_j$  and  $\hat{\beta}_{-j}$  are based on different data, they are statistically independent, and therefore the variance of their difference is the sum of their variances. If in fact all the values of  $\beta_j$  are equal, then the random variable  $Z_j$ , defined as

$$Z_j = (\hat{\beta}_j - \hat{\beta}_{-j}) / \text{s.d.}(\hat{\beta}_j - \hat{\beta}_{-j}),$$

will have mean 0 and variance 1. Here  $\text{s.d.}()$  denotes the standard deviation of the quantity in parentheses. A large observed absolute value of  $Z_j$  gives evidence that  $\beta_j$  is different from the average  $\beta$  for the components other than the  $j$ th. The significance level for the component is the probability that  $Z_j$  would be as far from zero as actually observed, if in fact all the components have the same  $\beta$ . Figures 5-2 and 5-3 illustrate this: if  $\hat{\beta}_j$  is far from  $\hat{\beta}_{-j}$ , compared to the length of the confidence interval for  $\hat{\beta}_j$ , the significance level, shown at the right edge of the figure, is small. If the two MLEs are close, the significance level is large. The significance is based on the normal approximation. When component  $j$  has only one non-replacement failure, the normal approximation is clearly poor and a better method

is used, as described in Section 6.1 of Appendix A.

When making multiple comparisons, as here when a comparison is made for each component, it is necessary to recognize that some values will appear extreme just because of random scatter. One way to account for this fact is with the Bonferroni inequality, discussed in many texts and by Alt (1982). In the present context, for any number  $c$  it says that

$$P(\text{at least one of } k \text{ significance levels is } \leq c) \leq kc.$$

The inequality is close to equality when  $kc$  is small. Therefore, the overall significance level for testing equality of the  $\beta_j$ s is the number of components examined times the minimum significance level calculated for a component. A small value of the attained overall significance level (say 0.05 or smaller) shows that there is strong evidence against the hypothesis that all the components have the same value of  $\beta$ . The overall attained significance level is shown in each of Figures 5-2 and 5-3.

The decision of what to do with an outlier should rest on engineering understanding of the possible causes of the anomalous behavior, not merely on statistical calculations. The statistical quantities may stimulate an engineer to discover a previously unrecognized difference between the outlying component and the others, justifying a split of the data. In other cases, careful engineering consideration of the components may lead to confidence that the components have no important differences, that the anomalous data just resulted from randomness; in such cases, the data would not be split.

**Testing Whether  $\beta = 0$ .** Suppose that, based on the analysis described above, we are willing to assume that the components have a common  $\beta$ . To test the hypothesis  $\beta = 0$ , the test statistic (5-1) can be used with  $\beta_o = 0$ , and the hypothesis rejected if the test statistic is in an extreme tail of the normal distribution. This is equivalent to rejecting the hypothesis if 0 is not within the confidence interval. The form of the test statistic depends on the assumed model. When the

exponential or linear failure rate model is assumed, the test statistic (5-1) becomes

$$[\sum(t_{ij} - \bar{s}_j)]/(\sum n_j r_j^2 / 12)^{1/2} , \quad (5-2)$$

where  $t_{ij}$  is the  $i$ th non-replacement failure of the  $j$ th component,  $\bar{s}_j$  is the midpoint of the observation period for the component, and the range  $r_j$  is the length of the observation period. If the statistic (5-2) is positive and far from zero, there is evidence of an increasing failure rate. This test was first proposed by Laplace (Bartholomew 1955).

When the Weibull failure rate model is assumed, statistic (5-1) takes a different form. In the case when every component is observed starting from its installation time, the test statistic becomes

$$\sum [1 + \log(t_{ij}/r_j)]/(\sum n_j)^{1/2} .$$

In the general case, the test statistic can be built from formulas given in Appendix A.

Although each test statistic has been motivated and derived based on a particular model, its asymptotic null distribution, normal(0,1), holds under the assumption that  $\beta = 0$ , that is, that  $\lambda(t)$  is constant. Therefore, either test is a valid test of the hypothesis of constant failure rate, even if the mathematical formula governing non-constant  $\lambda$  is not of the assumed form. The tests differ only in their power to detect various alternatives to the constant failure rate model.

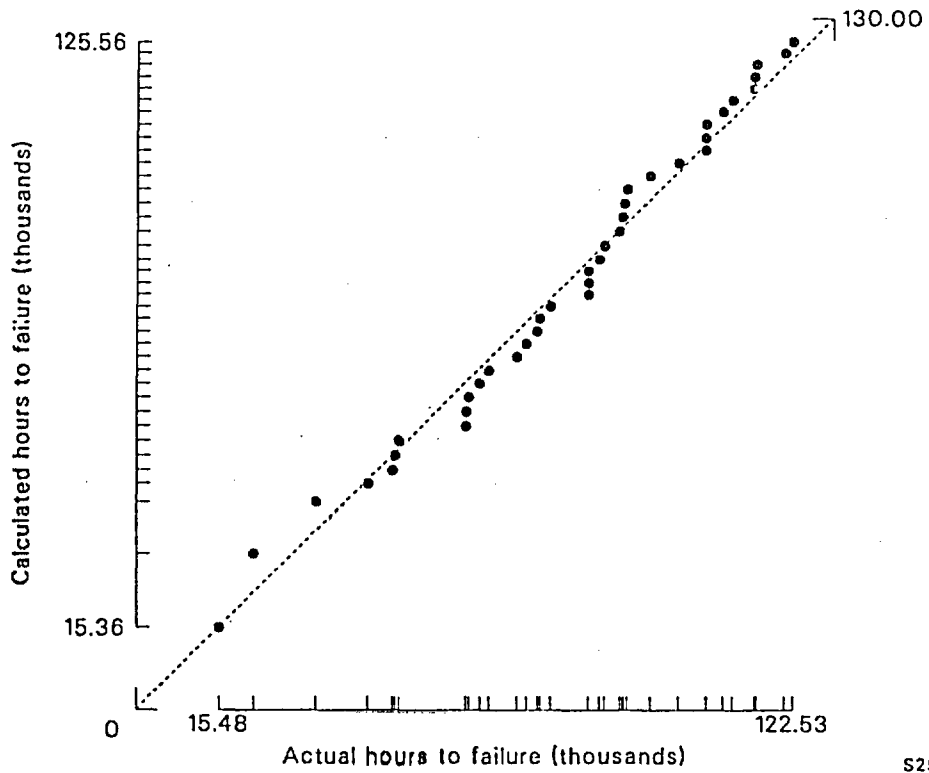
As mentioned in Section 2.5.1, a confidence interval provides information that a test result does not. Therefore, in addition to performing the test described here, it is helpful to find a confidence interval for  $\beta$  using statistic (5-1). This gives a range of plausible values of  $\beta$  and shows whether the uncertainty on  $\beta$  is small or large.

### 5.3.2 Investigating the Assumed Model Form.

**Q-Q Plot.** A Q-Q plot (see Snee and Pfeifer 1983) is a visual check of the correctness of an

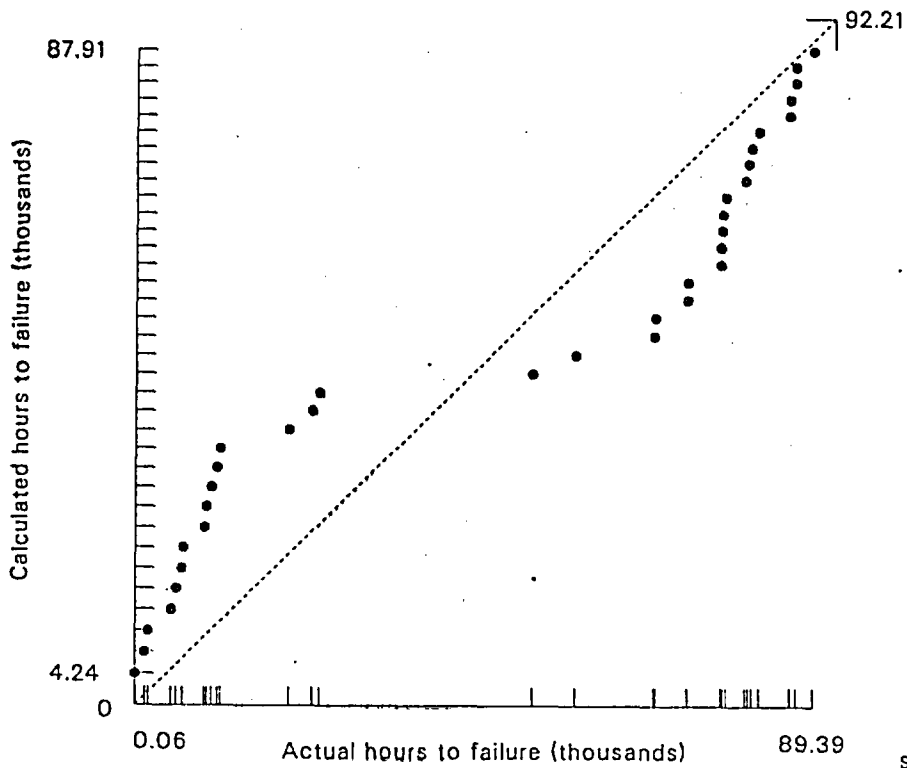
assumed distributional form that can be used in many contexts. In this context, let  $t_1 \leq \dots \leq t_n$  be the ordered observed ages at non-replacement failures. They represent sample quantiles corresponding to probabilities  $p_1 \leq \dots \leq p_n$ , with  $p_i$  set to  $i/(n+1)$ . For example, the median of the  $t_i$ s corresponds to  $p_i = 0.50$ . Let  $F$  denote the assumed cumulative distribution function, using estimated values for any unknown parameters. This  $F$  is the conditional distribution of the non-replacement failure times, conditional on the failure counts and the replacement times. The expression for an estimate of  $F$  is given in Section 6.3 of Appendix A. The Q-Q plot is a plot of  $F^{-1}(p_i)$  versus  $t_i$ , for  $i$  from 1 to  $n$ . The name "quantile-quantile" stems from the fact that  $F^{-1}(p_i)$  is the model-based estimate of the  $p_i$ -quantile, and  $t_i$  is a nonparametric estimate of the same quantile. The plot is useful as a check of the assumed form of  $F$ , because if the data really arise from  $F$ , the points of the Q-Q plot fall approximately on a straight line. Pronounced curvature or other departures from straightness should arouse suspicions about the correctness of the assumed form  $F$ . Figures 5-4 and 5-5 illustrate two Q-Q plots, with Figure 5-4 showing good fit to the assumed model and Figure 5-5 giving reason to question the model.

It is interesting to note that the cumulative failure plots given in Section 4.5 are equivalent to Q-Q plots. In those plots, the observed failure times are expressed as calendar hours from the beginning of the observation period, not as age of the components from their installation, but this is only a trivial difference. The number of components under observation at any time is constant because any component that is removed from service is immediately replaced by another. Therefore, if all the components have the same constant failure rate, then the failures are generated by a homogeneous Poisson process and the random failure times are uniformly distributed. The expected failure times,  $F^{-1}(p_i)$ , are therefore  $r/(n+1)$ ,  $2r/(n+1)$ ,  $\dots$ ,  $nr/(n+1)$ , where  $r$  is the length of the observation period in hours. The plots of Section 4 have their points plotted on the vertical axis at  $1, 2, \dots, n$ , which differ from the expected failure times only by a constant factor,



S252 SR-0690-21

Figure 5-4. Q-Q plot.



S241 CA-0590-02

Figure 5-5. Q-Q plot, based on hypothetical data.

$r/(n+1)$ . Therefore, except for a relabeling of the vertical axis, the plots are Q-Q plots for investigating whether the components all have the same constant failure rate. The reason why the diagonal line was drawn from (0,0) to  $(r,n+1)$  is that if the vertical axis were relabeled as is usual on a Q-Q plot, the diagonal line would go from (0,0) to  $(r,r)$ .

**Testing for the Form of  $\lambda(t)$ .** The Kolmogorov-Smirnov test, or some other similar nonparametric goodness-of-fit test, can be used to test whether data come from an assumed distribution. The data are the non-replacement failure times. The assumed distribution is  $F$ , used before for Q-Q plots and given in Section 6.3 of Appendix A. This test tends not to reject often enough; in statistical terminology, the Type I error is smaller than the nominal value. There are two reasons for this: one is that the estimated  $\beta$  is used to calculate  $F$ ; the other is that when the components are observed over different time periods, the data resemble a stratified sample rather than a true random sample. The fact that the test does not reject often enough is discussed in more detail in Section 6.3 of Appendix A.

This test can also be used to test whether all the components have the same constant failure rate, paralleling the use of cumulative failure plots as Q-Q plots. The hypothesis to be tested is that  $\beta = 0$  and that all components have the same value of  $\lambda_o$ . The corresponding distribution  $F$  is uniform, so no parameters need to be estimated. Therefore, the Kolmogorov-Smirnov test is a nonparametric exact test of the hypothesis that all the components have the same constant failure rate.

**5.3.3 Inference for  $\lambda_o$ , Given  $\beta$ .** Suppose at this point that the preceding analyses have led us to accept that the components have a common  $\beta$ , that  $\beta$  appears to be non-zero, and that the assumed form of  $\lambda(t)$  is consistent with the data. It is now time to consider  $\lambda_o$ .

**Estimation and Confidence Intervals for  $\lambda_o$ .** The average failure rate during a component's observation period can be estimated as the

observed number of failures divided by the observation time. If  $\beta$  is known or assumed, a calculation back to time zero (or to time  $t_o$  for the Weibull model) can be used to estimate  $\lambda_o$ . This is the conceptual basis for inference about  $\lambda_o$ , given  $\beta$ . The formulas are given in Appendix A.

**Component Comparisons for  $\lambda_o$ .** This diagnostic check is a parallel of the comparison method for  $\beta$ . The value of  $\beta$  now is treated as known and equal to  $\hat{\beta}$ . We investigate whether  $\lambda_o$  is the same for the  $j$ th component and for all the components except the  $j$ th. The mathematical methods are given in Section 6.2 of Appendix A. They are not based on normal approximations. Rather, they use the exact distributions of the failure counts (for time-censored data) and of the final failure times (for failure-censored data).

The theory in Appendix A assumes that all components have the same censoring type, either time censoring or failure censoring. In a typical data set, however, most of the components are time censored, but a few are replaced upon some failure and are therefore treated as failure censored. To analyze such data, when component  $j$  is compared to all the components except the  $j$ th, all components are treated as if they were censored the way component  $j$  was. For example, if component  $j$  was replaced at the time of its third failure, then all the components, not merely component  $j$ , are treated as if they were failure censored for this comparison. The reason is that the dominant uncertainty typically comes from the individual component with its few failures rather than from the many other components with their many failures.

These individual tests can be combined using the Bonferroni inequality, just as when testing for equality of the  $\beta$ s. A useful picture is a plot of confidence intervals for  $\lambda_o$ , each interval based on data from a single component, as shown in Figure 5-6. As was pointed out when we considered comparing components for  $\beta$ , engineering judgment must be used in deciding how to treat any outliers.

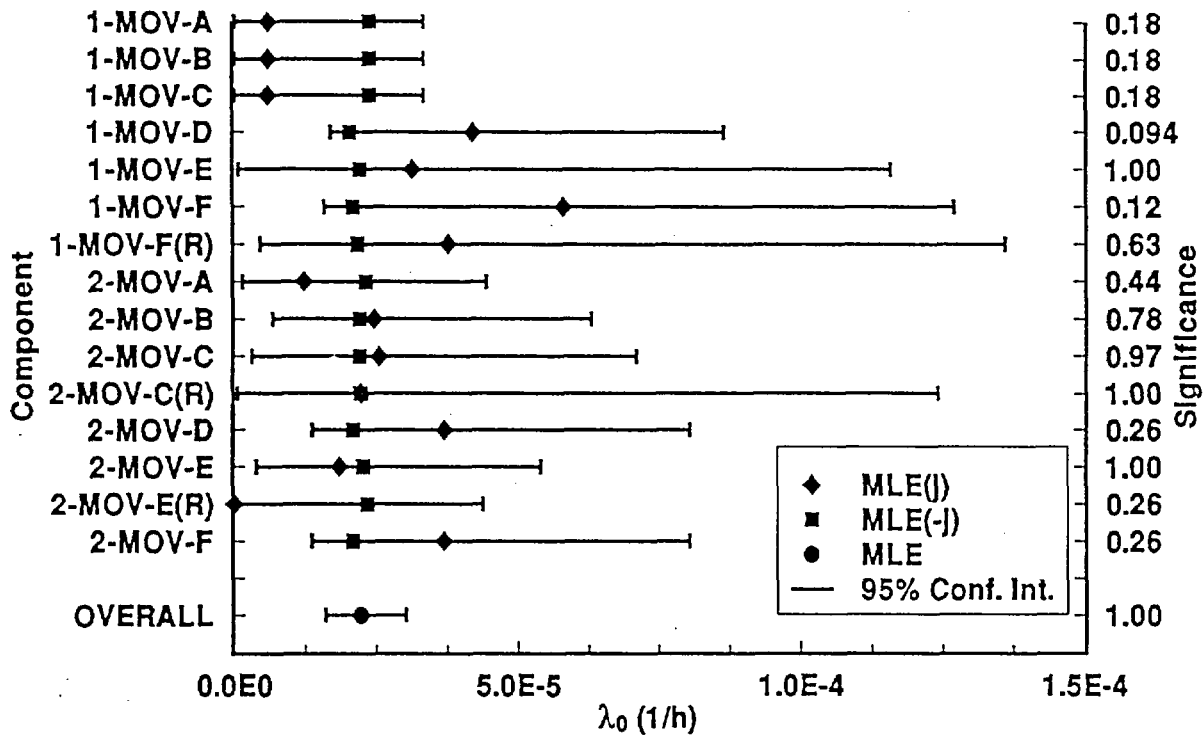


Figure 5-6. Component comparisons for  $\lambda_0$ .

### 5.3.4 Joint Inference for Both Parameters and for the Failure Rate.

#### Confidence Region for Both Parameters.

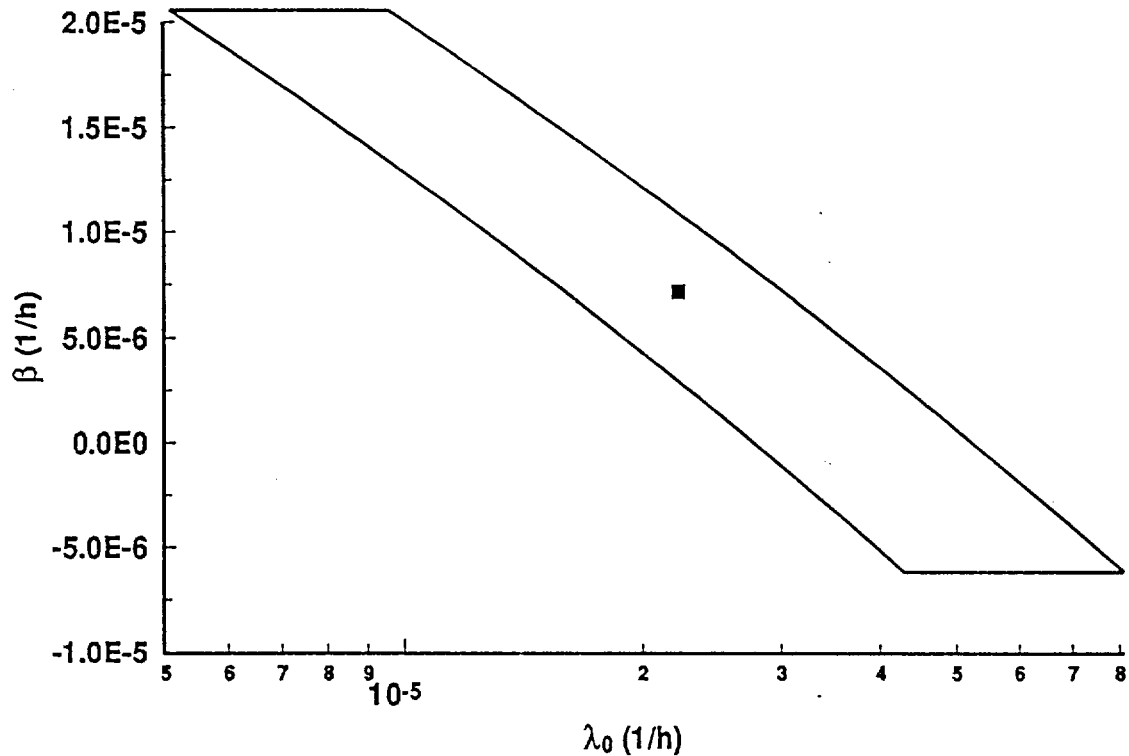
Suppose that a confidence interval for  $\beta$  has been found. Then for each value of  $\beta$  in the confidence interval, a confidence interval for  $\lambda_0$  can be found. This leads to a confidence region for  $(\beta, \lambda_0)$ , such as the one shown in Figure 5-7. If the one-dimensional confidence intervals each have confidence coefficient  $(1 - \alpha)$ , then the two-dimensional region has approximate coefficient  $(1 - 2\alpha)$ . For example, 95% confidence intervals for  $\beta$  and  $\lambda_0$  yield an approximate 90% confidence region for  $(\beta, \lambda_0)$ . Figure 5-7 is based on the exponential failure rate model with  $\lambda_0$  plotted on a logarithmic scale. The mathematical details are given in Appendix A, as are some other plots based on the exponential, Weibull, and linear failure rate models.

**Conservative Confidence Interval for the Failure Rate.** For any time  $t$  of interest, a conser-

vative confidence interval for  $\lambda(t) = \lambda_0 h(t; \beta)$  can be constructed as follows. Find the maximum and minimum values that  $\lambda(t)$  attains as  $\lambda_0$  and  $\beta$  range over the two-dimensional confidence region. These values are confidence bounds for  $\lambda(t)$ , with the same confidence coefficient that the confidence region has. The interval is conservative (possibly wider than necessary), because the shape of the joint confidence region was not designed to produce the shortest possible intervals.

**5.3.5 Joint Asymptotic Normality.** Until now, inference has been largely exploratory, not estimating any quantities until the relevant assumptions had been tested. Therefore  $\beta$  was estimated using the conditional likelihood to eliminate the assumption of a common  $\lambda_0$ , and when  $\lambda_0$  was eventually estimated, it was for each possible assumed  $\beta$ .

The viewpoint now changes. The model assumptions have been investigated and accepted. The goal is now to estimate the time-dependent failure rate  $\lambda(t)$  at various times  $t$ . For



**Figure 5-7.** 90% confidence region for  $(\beta, \lambda_o)$ , based on conditional likelihood.

this, both parameters are estimated simultaneously using maximum likelihood, based on the full (not conditional) likelihood. The formulas for the MLEs are given in Appendix A. Confidence regions are based on the joint asymptotic normality of the MLEs.

It turns out that the normal approximation is usually better when the model is parameterized in terms of  $\log \lambda_o$  rather than  $\lambda_o$ . This was discovered empirically, but has heuristic justifications: for failure-censored data, the log transformation replaces the scale parameter  $\lambda_o$  by a location parameter; also, the log transformation helps symmetrize the confidence intervals for  $\lambda_o$  for both types of censoring. The MLE of  $(\beta, \log \lambda_o)$  is asymptotically bivariate normal, and formulas for the asymptotic variance-covariance matrix are given in Appendix A.

**Approximate Confidence Region for Both Parameters.** Based on asymptotic normality, the confidence region for  $(\beta, \log \lambda_o)$  is an ellipse. Equivalently, the confidence region for  $(\beta, \lambda_o)$  is

elliptical when  $\lambda_o$  is plotted on a logarithmic scale.

To investigate whether the sample size is large enough for the normal approximation to be adequate, we can compare the two confidence regions for  $(\beta, \lambda_o)$ , one calculated as in Section 5.3.4 and the other being the confidence ellipse just described. If the two regions have substantial overlap, the normal approximation appears adequate. If the two regions are quite different, the normal approximation should not be used. Figure 5-8 shows the ellipse overlaid on the region of Figure 5-7, assuming the exponential failure rate. Figure 5-9 shows the overlaid regions based on the same data and a Weibull failure rate.

For the Weibull model, the normalizing time  $t_o$  was chosen in the middle of the observed failure times. In the example shown, it happens that the lower end of the 95% confidence limit for the Weibull  $\beta$  equals the theoretical lower limit of  $-1$ . This value is unattainable, but it is the lower confidence limit, and it forces  $\lambda_o$  to equal zero.

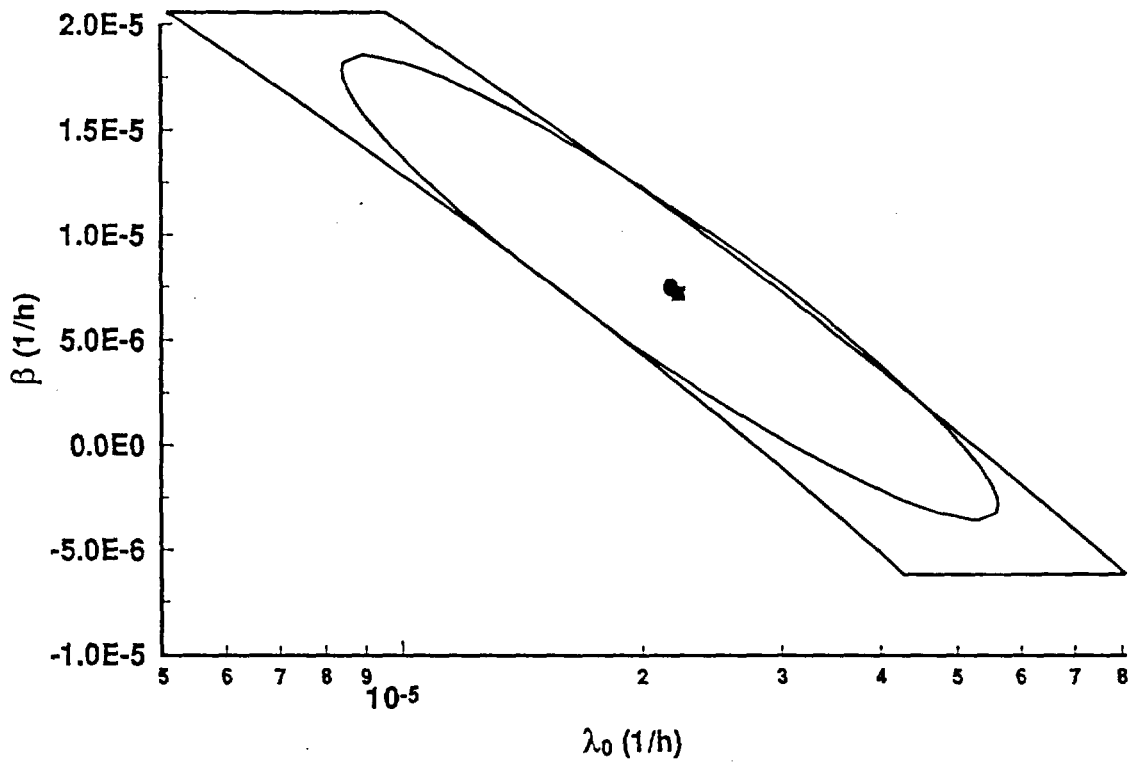


Figure 5-8. 90% confidence ellipse for  $(\beta, \lambda_o)$ , based on joint asymptotic normality, overlaid on the region of Figure 5-7.

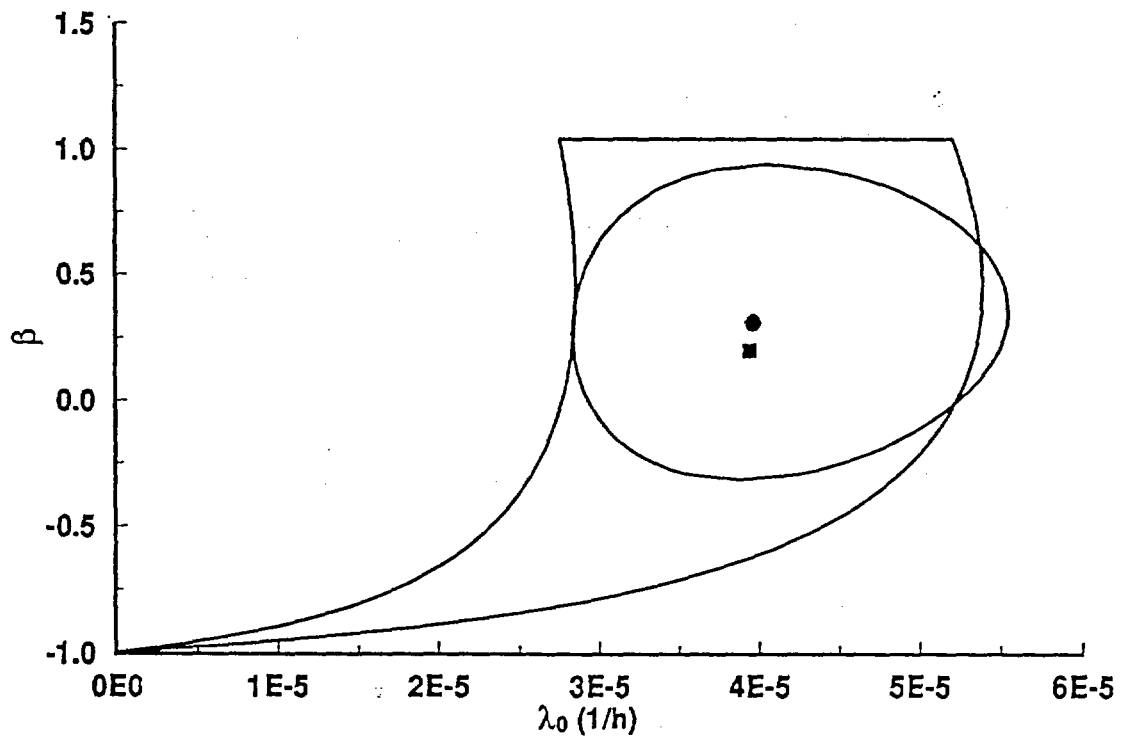


Figure 5-9. 90% confidence regions for  $(\beta, \lambda_o)$ , based on Weibull failure rate model with  $t_o$  at the middle of observation periods.



Therefore  $\lambda_o$  cannot be plotted on a logarithmic scale. In Figure 5-9, both parameters are plotted on a linear scale, distorting the ellipse slightly. Similar plots for the linear model are shown in Figures 5-10 and 5-11. With the linear model, time may be measured from an arbitrary origin, and the two figures show the confidence regions when time is measured from the component's installation and when time is measured from a point in the middle of the observation periods, respectively.

In Figure 5-8, the overlap of the two regions is quite good. The confidence ellipse is somewhat smaller, which is to be expected because it uses all the information in the full likelihood. In Figure 5-9 the overlap is also good, except when  $\beta$  is near the unattainable value of  $-1$ . In Figure 5-11 the overlap is not bad, while in Figure 5-10 the overlap is at best fair. A problem in Figures 5-10 and 5-11 is that the ellipse is truncated at the theoretical limits of  $\beta$ . The conclusions from these observations for this example are these: the normal approximation appears very good with the exponential failure rate model, adequate with the Weibull model, and inadequate (because of the truncation) with the linear model.

Similar figures for different data sets are shown in Figures 6-14 through 6-21 and in Appendix A.

**Confidence Band for the Failure Rate.**

Recall that the failure rate is assumed to be of the form

$$\lambda(t) = \lambda_o h(t; \beta)$$

so that a Taylor expansion yields

$$\begin{aligned} \log \hat{\lambda}(t) - \log \lambda(t) &\doteq \log \hat{\lambda}_o - \log \lambda_o \\ &+ (\hat{\beta} - \beta)(\partial/\partial\beta) \log[h(t; \beta)] \end{aligned}$$

For the three specific models considered in this report we have

$$\begin{aligned} \log \hat{\lambda}(t) - \log \lambda(t) &= \log \hat{\lambda}_o \\ &- \log \lambda_o + (\hat{\beta} - \beta)t \\ &\text{(exponential failure rate),} \end{aligned}$$

$$\begin{aligned} \log \hat{\lambda}(t) - \log \lambda(t) &= \log \hat{\lambda}_o - \log \lambda_o \\ &+ (\hat{\beta} - \beta) \log(t/t_o) \\ &\text{(Weibull failure rate), and} \end{aligned}$$

$$\begin{aligned} \log \hat{\lambda}(t) - \log \lambda(t) &\doteq \log \hat{\lambda}_o - \log \lambda_o \\ &+ (\hat{\beta} - \beta)t/(1 + \beta t) \\ &\text{(linear failure rate).} \end{aligned}$$

The first two equations are exact. The approximation for the linear failure rate model is adequate if  $(\hat{\beta} - \beta)t/(1 + \beta t)$  is not too large. For this case, let  $S$  denote the estimated standard deviation of  $\hat{\beta}$ . As a rule of thumb, the approximation may be judged adequate if  $|2St/(1 + \hat{\beta}t)|$  is less than 0.1, and fair if the quantity is less than 0.5. The possible need to keep  $t$  small may seem to restrict the approach to times near the components' installations. In fact, this is not the case because the time origin may be assigned arbitrarily. This is allowed in the algebraic formulas, as discussed in Appendix A. The meaning of  $\beta$  and  $\lambda_o$  depend on which point is defined as  $t = 0$ .

Therefore, for any model and for a sufficiently large sample, the MLE  $\log \hat{\lambda}(t)$  is approximately normal. Let  $D$  denote the derivative

$$(\partial/\partial\beta) \log[h(t; \beta)]$$

The approximate mean of  $\log \hat{\lambda}(t)$  is  $\log \lambda(t)$ , and the approximate variance equals

$$\text{var}(\log \hat{\lambda}_o) + D^2 \text{var}(\hat{\beta}) + 2D \text{cov}(\hat{\beta}, \log \hat{\lambda}_o)$$

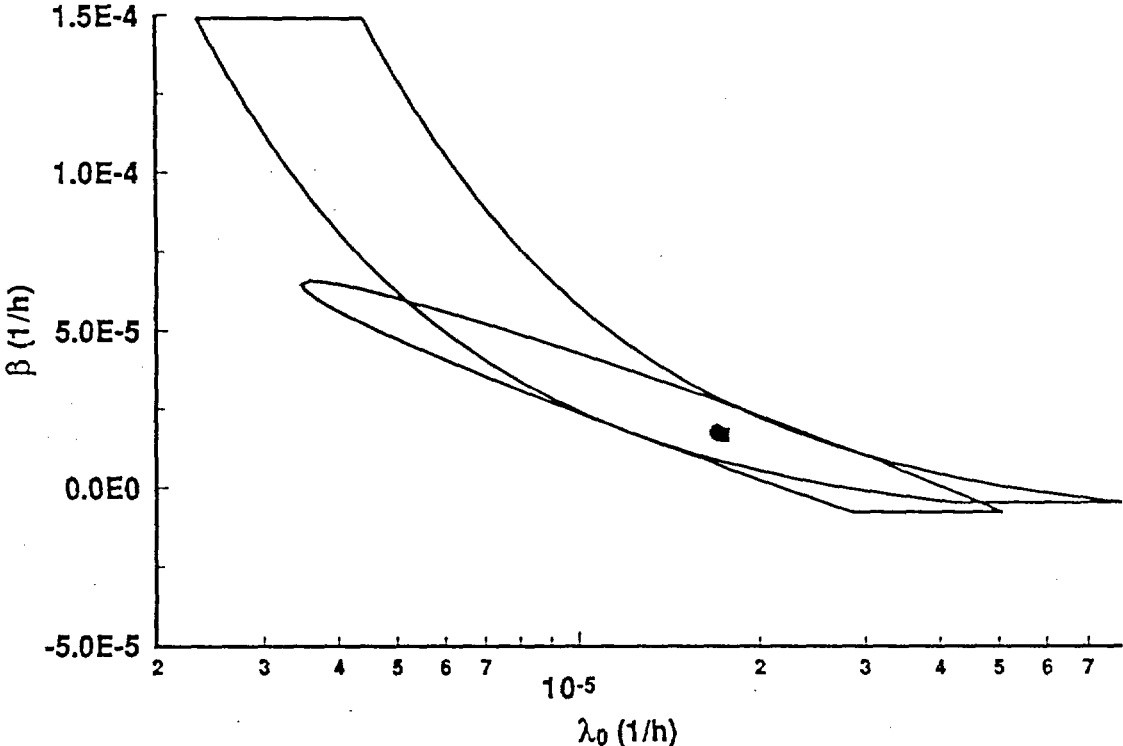


Figure 5-10. 90% confidence regions for  $(\beta, \lambda_0)$ , based on linear failure rate model with time measured from the component's installation.

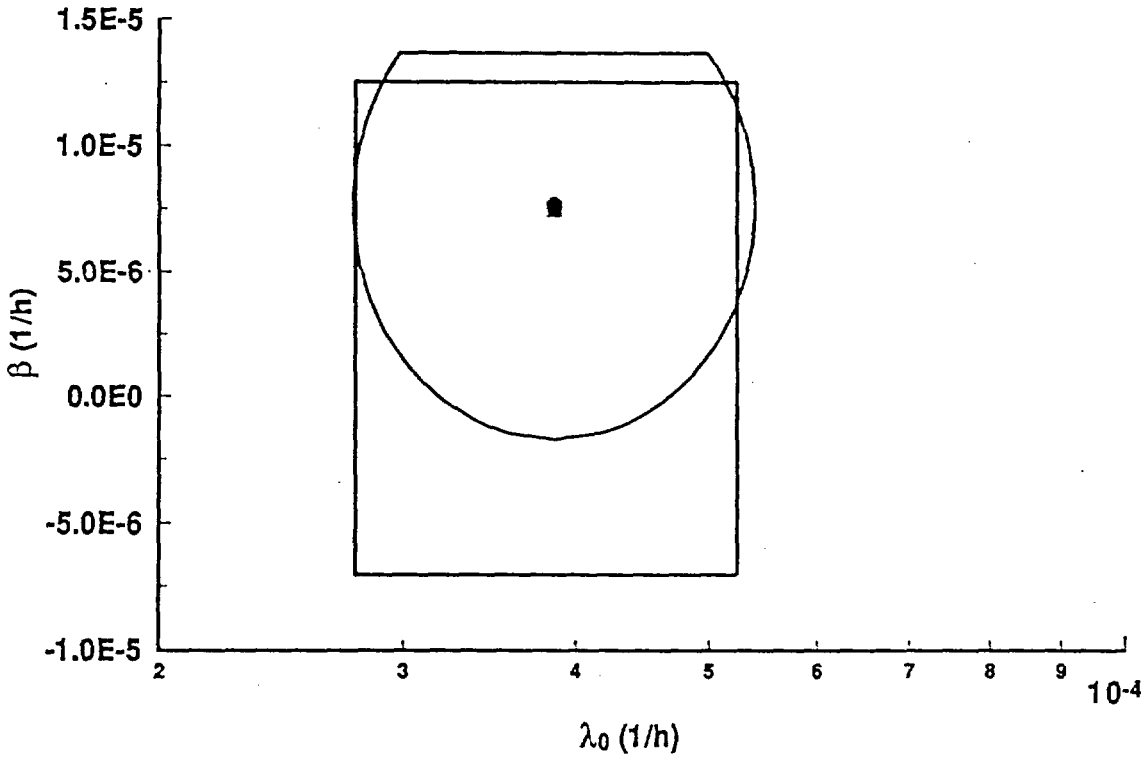


Figure 5-11. 90% confidence regions for  $(\beta, \lambda_0)$ , based on linear failure rate model with time measured from the middle of observation periods.

This yields an approximate confidence interval for  $\lambda(t)$  for any  $t$ . Figure 5-12 shows examples of the resulting bands for  $\lambda(t)$ , based on all three failure rate models.

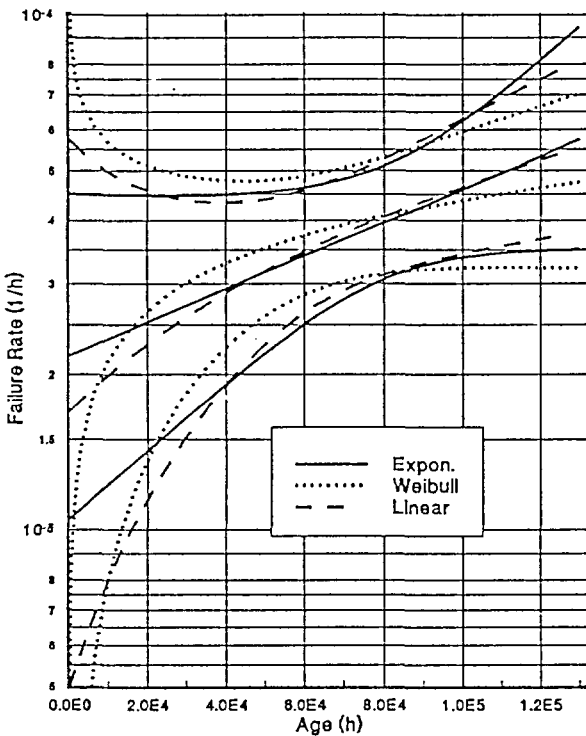
The band for the linear model (corresponding to Figure 5-11) is plotted in Figure 5-12 for comparative purposes, even though the joint normal approximation is poor. If the confidence band were seriously advocated, it would be plotted only for values of  $t$  satisfying

$$|2St/(1 + \hat{\beta}t)| < 0.5,$$

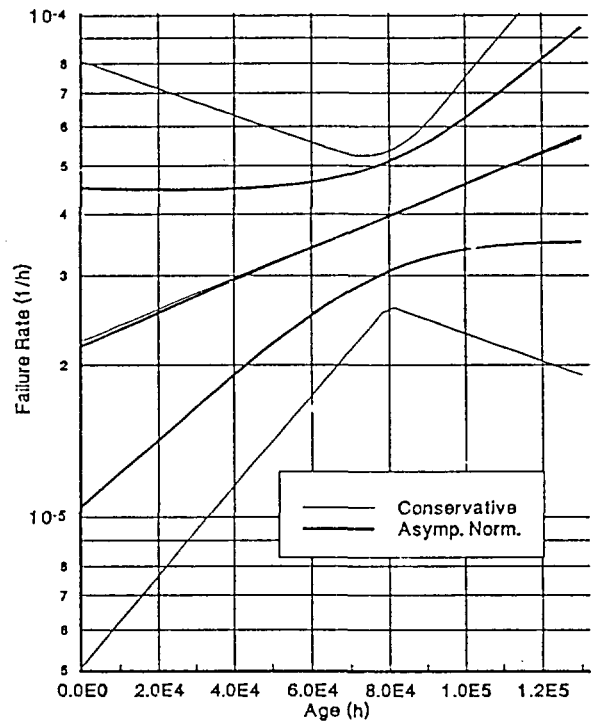
where  $S$  is the estimated standard deviation of  $\hat{\beta}$ ; outside this range, the first-order Taylor approximation is inadequate. This restriction corresponds to requiring  $t > 3.3E4$  hour. If the upper and lower bounds for the linear model are ignored where  $t < 3.3E4$  hour, the bands for the three

models look similar, except that the Weibull failure rate approaches 0 at time 0. Moreover, the exponential band forms an envelope for the linear band as the graph is extrapolated to the right. These observations support the decision to report only confidence limits based on the exponential and Weibull models.

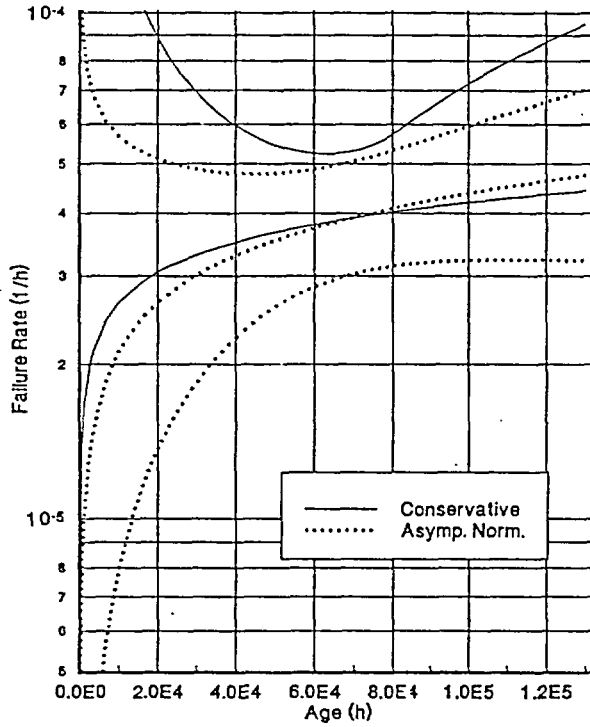
When the asymptotic normal approximation seems unsuitable, an alternative is to use the conservative band for the failure rate (Section 5.3.4). For the three models and the MOV data, the confidence bands based on asymptotic normality and on conservative calculations are shown in Figures 5-13 through 5-15. In this example, the conservative bands are much wider than the bands based on normality. The Weibull lower bound is not shown because it is zero. With other data sets, the bands based on conservative bounds and on approximate normality differ less.



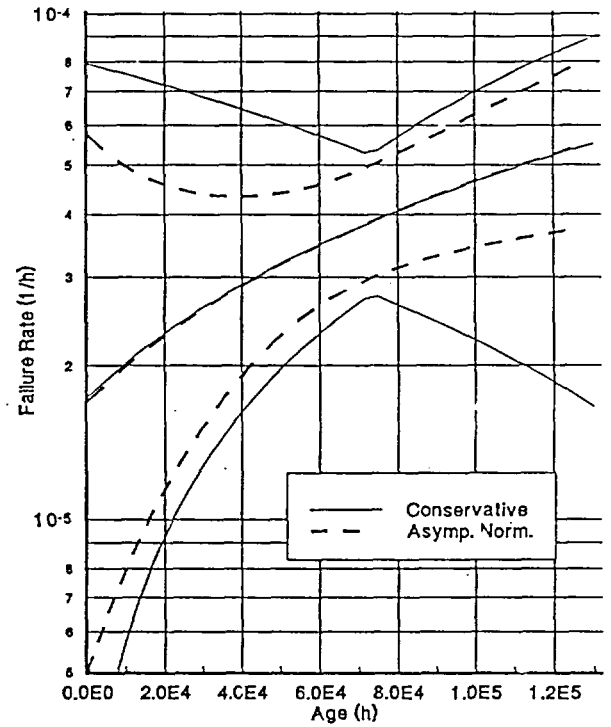
**Figure 5-12.** MLE and 90% confidence band for  $\lambda(t)$ , based on joint asymptotic normality for all three models.



**Figure 5-13.** MLEs and 90% confidence bands for  $\lambda(t)$ , based on conservative calculations and on asymptotic normality for exponential model.



**Figure 5-14.** MLEs and 90% confidence bands for  $\lambda(t)$ , based on conservative calculations and on asymptotic normality for Weibull model.



**Figure 5-15.** MLEs and 90% confidence bands for  $\lambda(t)$ , based on conservative calculations and on asymptotic normality for linear model.

## 6. TIME-DEPENDENT FAILURE DATA ANALYSIS

The process used for analyzing the component failure data is illustrated in Figure 6-1, which is essentially the same as Figure 5-1 and expands a portion of Figure 2-2. The individual steps to perform the analysis are described in the following sections.

### 6.1 Preparation of the Input

The raw failure-time data sets developed as described in Section 4 were the source of data for this analysis. A FORTRAN computer program, PHAZE (Atwood 1990), was written to carry out the approach presented in Section 5. A data file was a coded representation of the failure occurrence timeline that contained the data for each of the individual components as a series of records. In each record, the component name was stated first, then the beginning and ending dates of observation, followed by the specific failure dates. If a component was replaced at the end of its observation period, then the last date of failure was given the trailing designator, R. Tables 6-1 and 6-2 present the formatted input failure data for the broadly and narrowly defined failures, respectively. These data sets correspond exactly to the timelines of Section 4.

### 6.2 Statistical Screening Analysis

#### 6.2.1 Common $\beta$ Test for All Components.

A single component of a nuclear safety system will rarely incur enough failures, even over its installed life, to analyze singly. Therefore, component failure histories must be combined, or pooled, together. Pooling of component failure data by type for use in quantification of PRAs has become a casual, and sometimes untested, standard practice. Good practice for data analysis, however, requires that data from the individual components be examined and compared before being pooled.

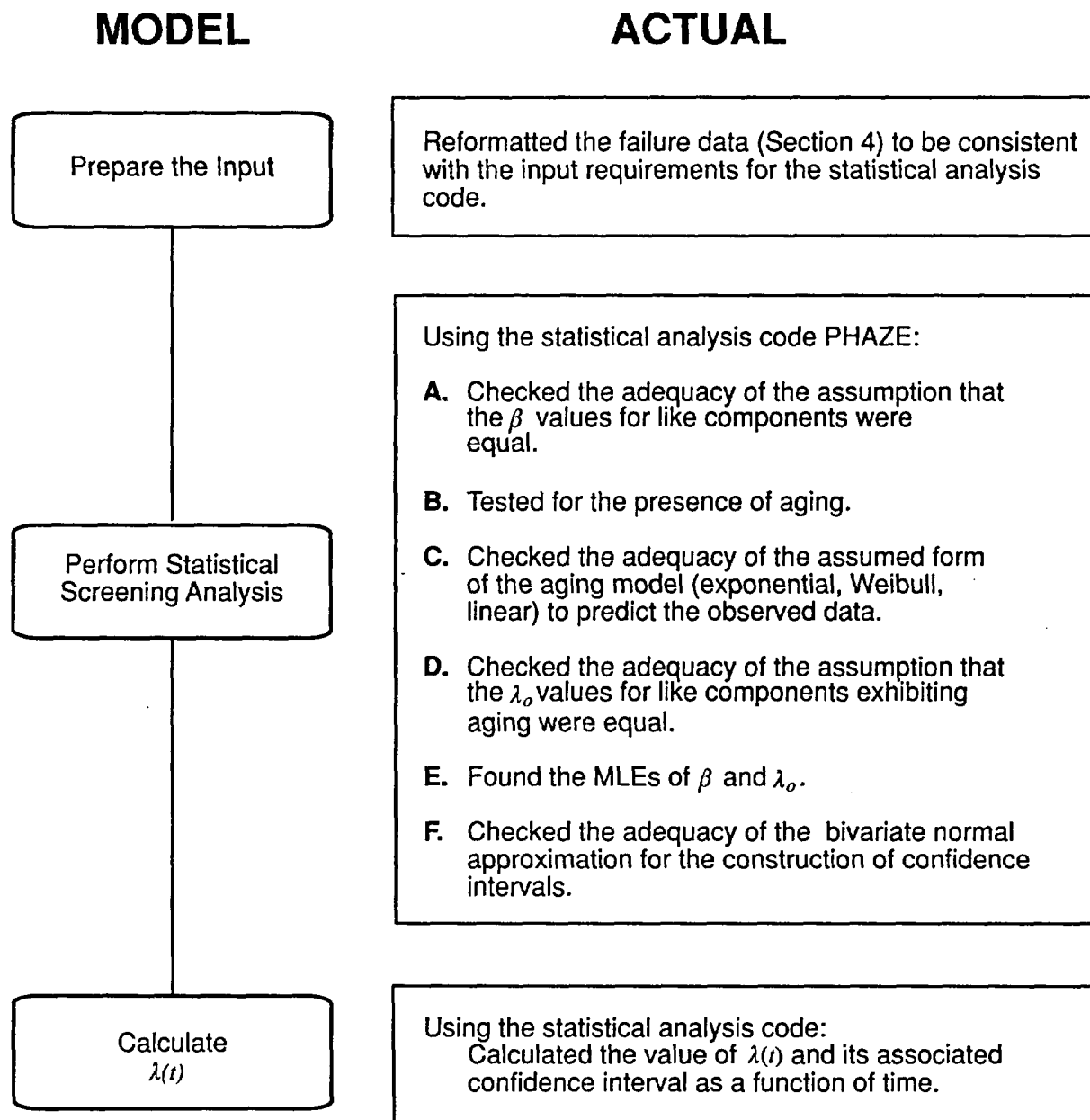
The pooling of component failure data is determined to be acceptable or not depending on the

significance level for the test of the equality of  $\beta$  (see Section 5.3.1). If the significance level were less than 0.05 (meaning that there is less than a 5% chance that such disparate component data could arise if  $\beta$  is the same for all components), then the pooling assumption would be rejected and the significance levels and confidence interval plots associated with the component comparisons would be visually checked for indication of an outlier. Engineering judgement would be used to help decide whether to treat the outlier(s) separately.

In this analysis of AFW system components, the value of the significance level ranged from 0.15 to 1.00 for all but one set of components discussed separately below. The values are shown in Tables 6-3 and 6-4. Therefore, the assumption of equality of  $\beta$  was accepted, and all components passed this step in the screening process. Use of the confidence interval plots for identification of outliers was not necessary because all significance levels were greater than 0.05. However, to help the reader visualize the process, a typical confidence interval plot for  $\beta$  is shown in Figure 5-2. The plot is shown for the 3-in. MOVs, the broad failure definition, and the failure mode AFW-MOV-PG. The overall significance level is 0.83, indicating that equality of  $\beta$  is a good assumption.

One data set, AFW-MOV-FC for narrowly defined failures, showed a significance level of 0.05 based on the linear model. However the extreme component in this case had  $\hat{\beta}_j = \infty$ , which was based on one observed failure. Therefore, we did not feel that there was enough information to justify any decision. Because the exponential model had allowed the components to be pooled, the components were also pooled with the linear model.

One disturbing feature shown in Tables 6-3 and 6-4 is the frequent inability of the linear model and the occasional inability of the Weibull model to provide an answer to the test for equality. This is a result of the mathematics associated with the



LF91 0313

Figure 6-1. Process used to develop time-dependent failure rates.

**Table 6-1.** Formatted data used for the analysis of broadly defined failures.

Mark number	In service date <sup>a</sup>	Start and end dates <sup>a</sup> of observations	Number of failures	Date <sup>a</sup> of failure
<i>Failure Mode AFW-PMP-FR</i>				
1-TDP	721201	770824 871001	13	780111 780303 790204 790420 791223 800210 800429 820824 840111 850214 860509 860820 860907
2-TDP	730501	770824 871001	11	801118 820513 821207 830216 830314 830321 830429 830927 831013 840330 850819
<i>Failure Mode AFW-PMP-FS</i>				
1-MDP-A2	721201	770824 871001	5	810522 830611 820320 820330 86082
1-MDP-B	721201	770824 871001	3	810522 860826 870522
2-MDP-A	730501	770824 871001	4	790209 790910 831006 831012
2-MDP-B	730501	770824 871001	4	790207 790910 800725 850712
<i>Failure Mode AFW-PMP-FR</i>				
1-MDP-A	721201	770824 871001	5	791223 810101 810114 810201 821014
1-MDP-B	721201	770824 871001	2	810114 820309
2-MDP-A	730501	770824 871001	2	790324 870331
2-MDP-B	730501	770824 871001	2	810616 870807
<i>Failure Mode AFW-MOV-PG</i>				
1-MOV-A	721201	770824 871001	1	810618
1-MOV-B	721201	770824 871001	1	780706
1-MOV-C	721201	770824 871001	1	830423
1-MOV-D	721201	770824 871001	7	830411 830520 840620 850814 860128 860131 861123
1-MOV-E	721201	770824 800219	1	800219 R <sup>b</sup>
1-MOV-F	721201	770824 820814	4	780605 810325 811001 820814 R <sup>b</sup>
1-MOV-F(R)	820815	820815 871001	2	821018 850213
2-MOV-A	730501	770824 871001	2	781015 851029
-MOV-B	730501	770824 871001	4	800826 801104 821218 850620
2-MOV-C	730501	770824 830426	2	811207 830426 R <sup>b</sup>
2-MOV-C(R)	830427	830427 871001	1	870225

# Time-Dependent Failure Data Analysis

**Table 6-1.** (continued).

Mark number	In service date <sup>a</sup>	Start and end dates <sup>a</sup> of observations	Number of failures	Date <sup>a</sup> of failure
2-MOV-D	730501	770824 871001	6	780407 800513 800602 821218 850620 860715
2-MOV-E	730501	770824 871001	3	810611 830313 870219
2-MOV-E(R)	800323	800323 871001	0	
2-MOV-F	730501	770824 871001	6	800509 821218 830424 830819 840412 850620
<i>Failure Mode AFW-PSF-FC-XCONN</i>				
1-MOV-G	721201	770824 871001	3	810423 811212 850823
1-MOV-H	721201	770824 871001	2	860211 860807
2-MOV-I	730501	770824 800807	1	800807 R <sup>b</sup>
2-MOV-I(R)	800807	800808 871001	1	830423
2-MOV-J	730501	770824 871001	5	781006 781204 800814 810120 830423
<i>Failure Mode AFW-CKV-OO<sup>c</sup></i>				
1-CV-A	721201	770824 871001	3	830520 870214 870528
1-CV-B	721201	770824 871001	1	830525
1-CV-C	721201	770824 871001	1	830504
2-CV-A	730501	770824 871001	2	830117 831129
2-CV-B	730501	770824 871001	0	
2-CV-C	730501	770824 871001	5	830926 831119 840128 840313 841218
<i>Failure Mode AFW-PMP-LK-STMBD</i>				
1-TDP	721201	770824 871001	0	
1-MDP-A	721201	770824 871001	0	
1-MDP-B	721201	770824 871001	0	
2-TDP	730501	770824 871001	1	831120
2-MDP-A	730501	770824 871001	0	
2-MDP-B	730501	770824 871001	1	831118

a. Note that date format is year, month, and day.

b. R indicates that the component was replaced at the date of the final failure.

c. Following discussion with personnel from the power station, the CV events were reinterpreted as non-failures, and the data file was no longer used. See Section 6.2.3.



**Table 6-2.** Formatted data used for the analysis of narrowly defined failures.

Mark number	In service date <sup>a</sup>	Start and end dates <sup>a</sup> of observations	Number of failures	Date <sup>a</sup> of failure
<i>Failure Mode AFW-PMP-FR</i>				
1-TDP	721201	770824 871001	2	780111 860907
2-TDP	730501	770824 871001	3	801118 830216 830321
<i>Failure Mode AFW-PMP-FS</i>				
1-MDP-A	721201	770824 871001	2	820330 830611
1-MDP-B	721201	770824 871001	0	
2-MDP-A	730501	770824 871001	1	831012
2-MDP-B	730501	770824 871001	1	800725
<i>Failure Mode AFW-PMP-FR</i>				
1-MDP-A	721201	770824 871001	0	
1-MDP-B	721201	770824 871001	0	
2-MDP-A	730501	770824 871001	0	
2-MDP-B	730501	770824 871001	0	
<i>Failure Mode AFW-MOV-PG</i>				
1-MOV-A	721201	770824 871001	0	
1-MOV-B	721201	770824 871001	1	780706
1-MOV-C	721201	770824 871001	0	
1-MOV-D	721201	770824 871001	4	830520 840620 850814 860128
1-MOV-E	721201	770824 800219	1	800219 R <sup>b</sup>
1-MOV-F	721201	770824 820814	2	811001 820814 R <sup>b</sup>
1-MOV-F(R)	820815	820815 871001	1	850213
2-MOV-A	730501	770824 871001	2	781015 851029
2-MOV-B	730501	770824 871001	1	801104
2-MOV-C	730501	770824 830426	1	830426 R <sup>b</sup>
2-MOV-C(R)	830427	830427 871001	0	

## Time-Dependent Failure Data Analysis

**Table 6-2.** (continued).

Mark number	In service date <sup>a</sup>	Start and end dates <sup>a</sup> of observations	Number of failures	Date <sup>a</sup> of failure
2-MOV-D	730501	770824 871001	2	800602 860715
2-MOV-E	730501	770824 871001	1	870219
2-MOV-E(R)	800323	800323 871001	0	
2-MOV-F	730501	770824 871001	1	800509
<i>Failure Mode AFW-PSF-FC-XCONN</i>				
1-MOV-G	721201	770824 871001	1	811212
1-MOV-H	721201	770824 871001	1	860211
2-MOV-I	730501	770824 800807	1	800807 R <sup>b</sup>
2-MOV-I(R)	800807	800808 871001	0	
2-MOV-J	730501	770824 871001	3	781006 781204 810120
<i>Failure Mode AFW-PMP-LK-STMBD</i>				
1-TDP	721201	770824 871001	0	
1-MDP-A	721201	770824 871001	0	
1-MDP-B	721201	770824 871001	0	
2-TDP	730501	770824 871001	1	831120
2-MDP-A	730501	770824 871001	0	
2-MDP-B	730501	770824 871001	1	831118

a. Note that date format is year, month, and day.

b. R indicates that the component was replaced at the date of the final failure.

**Table 6-3.** Results of statistical analysis of the broadly defined failures.

Failure mode	Significance level for testing equality of $\beta^a$			Significance level for testing $\beta = 0^b$			Significance level for testing adequacy of model			Significance level for testing equality of $\lambda_o^a$			Conclusion at confidence levels	
	Exponential	Weibull	Linear	Exponential	Weibull	Linear	Exponential	Weibull	Linear	Exponential	Weibull	Linear	0.05	0.40
AFW-PMP-FR-TDP	0.29	0.15	— <sup>c</sup>	0.55	0.47	0.55		N/A			N/A	N/A	Not aging	Not aging
AFW-PMP-FS-MDP	0.52	0.55	0.72	0.52	0.48	0.52		N/A			N/A	N/A	Not aging	Not aging
AFW-PMP-FR-MDP	0.97	0.97	0.84	0.70	0.63	0.70		N/A			N/A	N/A	Not aging	Not aging
AFW-MOV-PG	0.83	0.46	0.93	0.15	0.32	0.15	0.83	0.53	0.85	1.00	1.00	1.00	Not aging	Aging
AFW-MOV-FC	0.25	0.56	0.80	0.65	0.56	0.65		N/A			N/A	N/A	Not aging	Not aging
AFW-PMP-LK-STMBD	0.88	0.78	— <sup>c</sup>	0.28	0.23	0.28	>0.20	>0.20	>0.20	1.00	1.00	1.00	Not aging	Aging
AFW-CKV-OO <sup>d</sup>	1.00	1.00	— <sup>c</sup>	0.02	0.02	0.02	0.06	0.04	0.09	0.18	0.18	0.18	Aging	Aging

a. A value of 0.05 or less indicates strong evidence that the components do not have the same aging rate,  $\beta$ , or the same initial failure rate,  $\lambda_o$ .

b. A value of 0.05 or less indicates strong evidence that the components failures were not generated by a constant failure rate process. A value of 0.40 or less indicates weak statistical evidence of aging but is investigated as aging in order to be conservative for the sake of safety.

c. Could not be calculated for this case.

d. Following discussion with personnel from the power station, these events were all reinterpreted as non-failures, and the data file was no longer used. See Section 6.2.3.

**Table 6-4.** Results of statistical analysis of the narrowly defined failures.

Failure mode <sup>a</sup>	Significance level for testing equality of $\beta^b$			Significance level for testing $\beta = 0^c$			Significance level for testing adequacy of model			Significance level for testing equality of $\lambda_o^b$			Conclusion at confidence levels	
	Exponential	Weibull	Linear	Exponential	Weibull	Linear	Exponential	Weibull	Linear	Exponential	Weibull	Linear	0.05	0.40
AFW-PMP-FR-TDP	0.98	0.69	— <sup>d</sup>	0.59	0.59	0.59		N/A			N/A		Not aging	Not aging
AFW-PMP-FS-MDP	1.00	1.00	0.34	0.55	0.45	0.55		N/A			N/A		Not aging	Not aging
AFW-MOV-PG	0.84	0.85	0.72	0.24	0.25	0.24	>0.20	>0.20	>0.20	0.94	0.98	0.95	Not aging	Aging
AFW-MOV-FC	0.13	— <sup>d</sup>	0.05	0.85	0.85	0.85		N/A			N/A		Not aging	Not aging
AFW-PMP-LK-STMBD	0.88	0.78	— <sup>d</sup>	0.28	0.23	0.28	>0.20	>0.20	>0.20	1.00	1.00	1.00	Not aging	Aging

- a. There were no narrowly defined failures for modes AFW-CKV-OO and AFW-PMP-FR-MDP. The narrowly and broadly defined failures for mode AFW-PMP-LK-STMBD were identical.
- b. A value of 0.05 or less indicates strong evidence that the components do not have the same aging rate,  $\beta$ , or the same initial failure rate,  $\lambda_o$ .
- c. A value of 0.05 or less indicates strong evidence that the components failures were not generated by a constant failure rate process. A value of 0.40 or less indicates weak statistical evidence of aging but is investigated as aging in order to be conservative for the sake of safety.
- d. Could not be calculated for this case.

models. In mathematical terms, they are not well-behaved. While this is inconvenient, it does not prevent the use of the models for other sets of data, and with the support of the exponential model, does not necessarily prevent the further application of the Weibull and linear models. For example, even though the linear model was incapable of providing a result for the case of the narrowly defined, pump steam-binding failure, both the exponential and Weibull models indicated acceptance of the equality of the  $\beta$ s. Therefore, the linear model continued to be applied to this case as though the set of components had shown equality using this model.

**6.2.2 Aging Test.** After the test for common  $\beta$ , the next task was to test for statistically significant aging. The significance level of the null hypothesis,  $\beta = 0$ , was checked for all sets of components passing the first screening test. Recall that the null hypothesis assumed a homogeneous Poisson process, implying constant failure rate. The test for significance must identify any statistically significant evidence to the contrary. Therefore, evidence of an increasing rate of failure, assumed in this report to be aging, can be modeled by a positive  $\beta$ .

The approach for analyzing data for the presence of aging used two significance levels, 0.05 and 0.40 (Section 2.5). Traditional statistics would use only the 0.05 value for testing statistical significance of aging. However, for a safety analysis it can be argued that the relaxation of this convention is conservative and, therefore, justified. The result is that components are identified in which there is less confidence that the aging trend is present. Frequently, these components have a large uncertainty, indicating the need for more data to make any confident statement on the failure trends. The result of including components to the 0.40 significance level is that more aging, and thus more risk, is predicted than may actually be present. This is generally conservative and, therefore, acceptable.

The significance level values for  $\beta = 0$  ranged from 0.85 to 0.02, as shown in Tables 6-3 and 6-4. One broadly defined failure set and no narrowly

defined failure sets exhibited significance levels less than 0.05. The broadly defined failure set was the pump discharge header check valve backflow failure (AFW-CKV-OO). After the check valve maintenance records were reinterpreted, as described below, no data sets showed aging at a significance level less than 0.05. Two additional sets exhibited aging at the 0.40 level of significance for both the broadly and narrowly defined failures. These two sets were the 3-in. MOV plugging failure (AFW-MOV-PG) and pump steam binding failure (AFW-PMP-LK-STMBD).

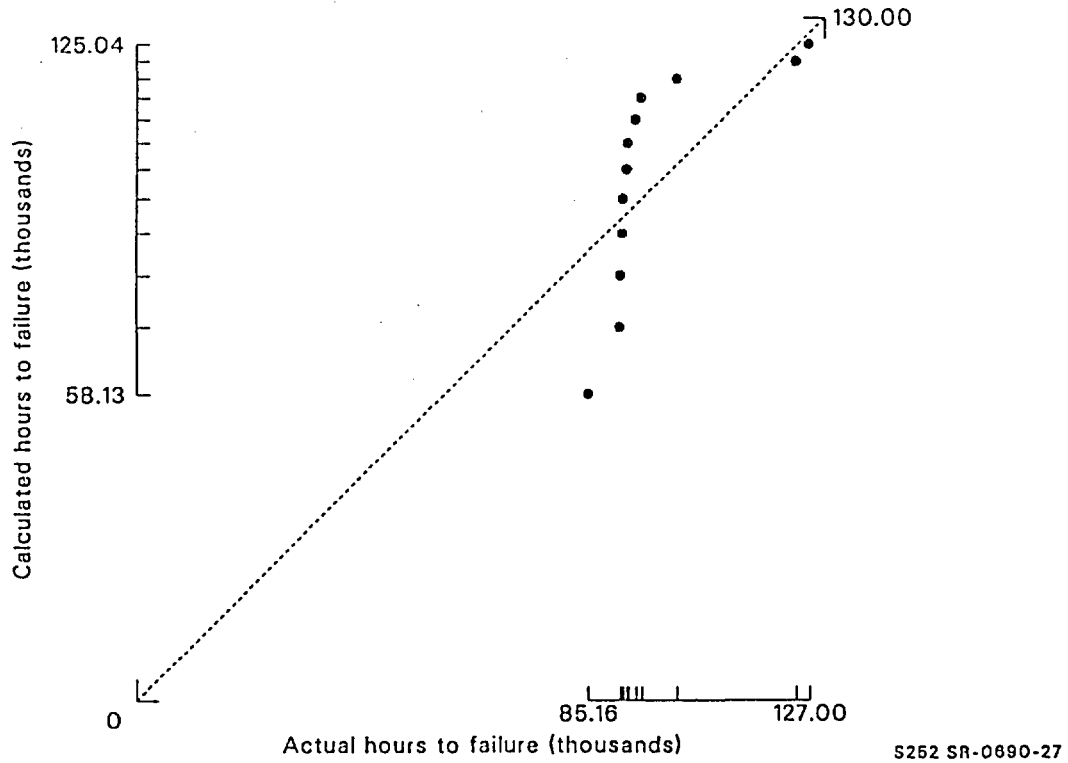
### 6.2.3 Adequacy Check of the Assumed Form of the Aging Model.

Initially the five component failure data sets that showed indication of aging at either the 0.05 or 0.40 significance level were tested to see if any of the three assumed model forms provided an adequate description of the data. As in the previous screening, 0.05 was used to test the assumption (Section 5.3.2). The hypothesized model form would be accepted if the failure times predicted by the model were close to the actual failure times. For all the data sets except one, the level of significance ranged from 0.20 to 0.85, as shown in Tables 6-3 and 6-4. For backflow of the check valves, the significance level was from 0.04 to 0.09, depending on the assumed model.

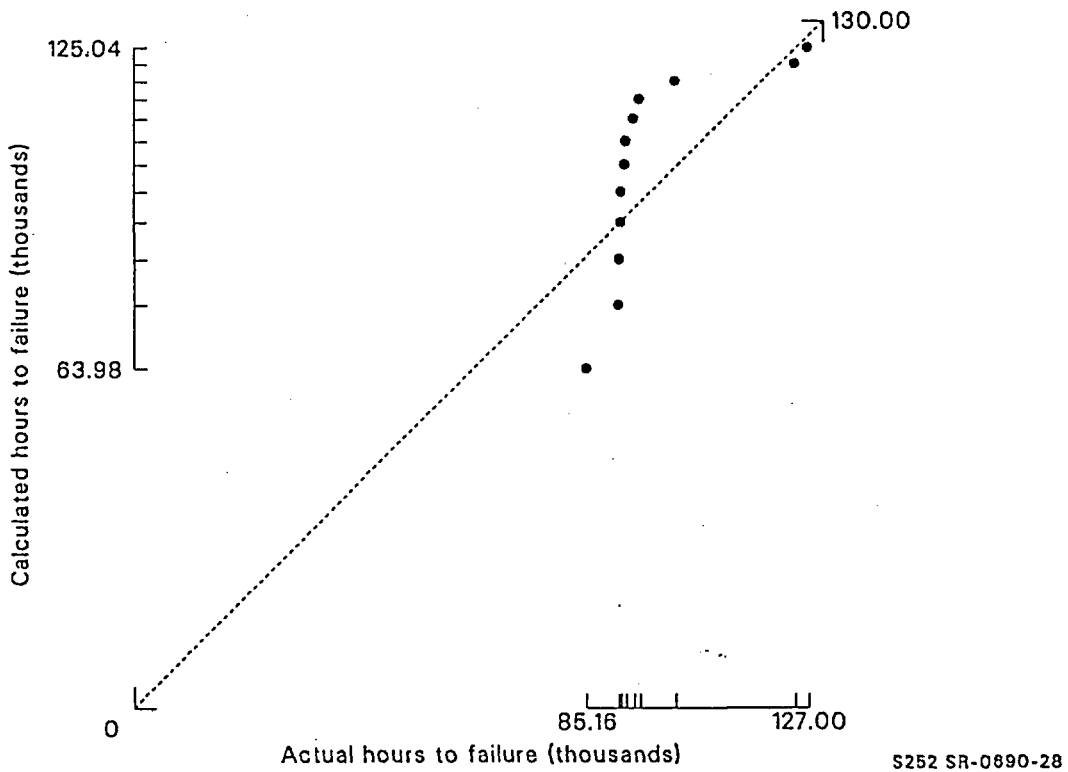
The Q-Q plots (Section 5.3.2) for the five data sets for each of the three models (shown in Figures 6-2 to 6-13) are consistent with the significance levels shown in Tables 6-3 and 6-4. The plots indicate that some clustering of data occurred, but except for backflow of the check valves, the plots show no gross deviations from the 45-degree line that represents perfect agreement between actual and predicted failure times.

For backflow of the check valves (failure mode AFW-CKV-OO), based on the broad definition of failures, clustering of the failure dates made the fit to any of the models marginal at best. The clustering of failure times is shown in the timeline (Figure 4-16), in the cumulative failure plot (Figure 4-17), and in the corresponding Q-Q plots (Figures 6-2 through 6-4). Several possible causes of this clustering were conjectured, but the

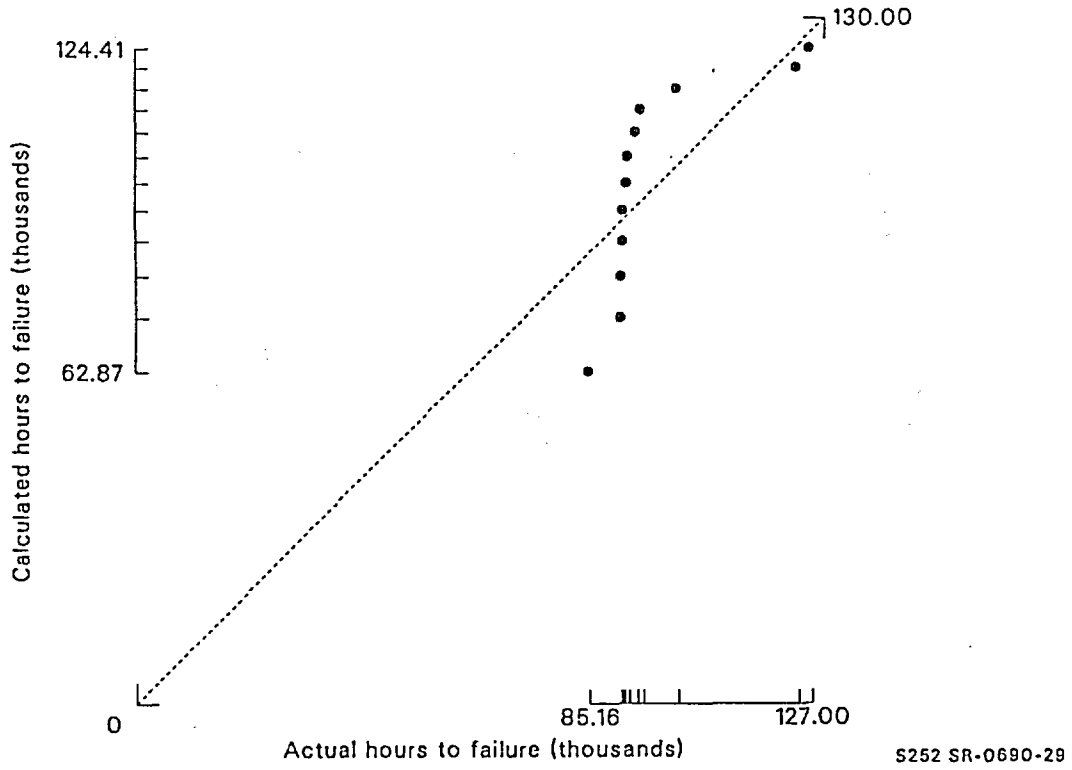
# Time-Dependent Failure Data Analysis



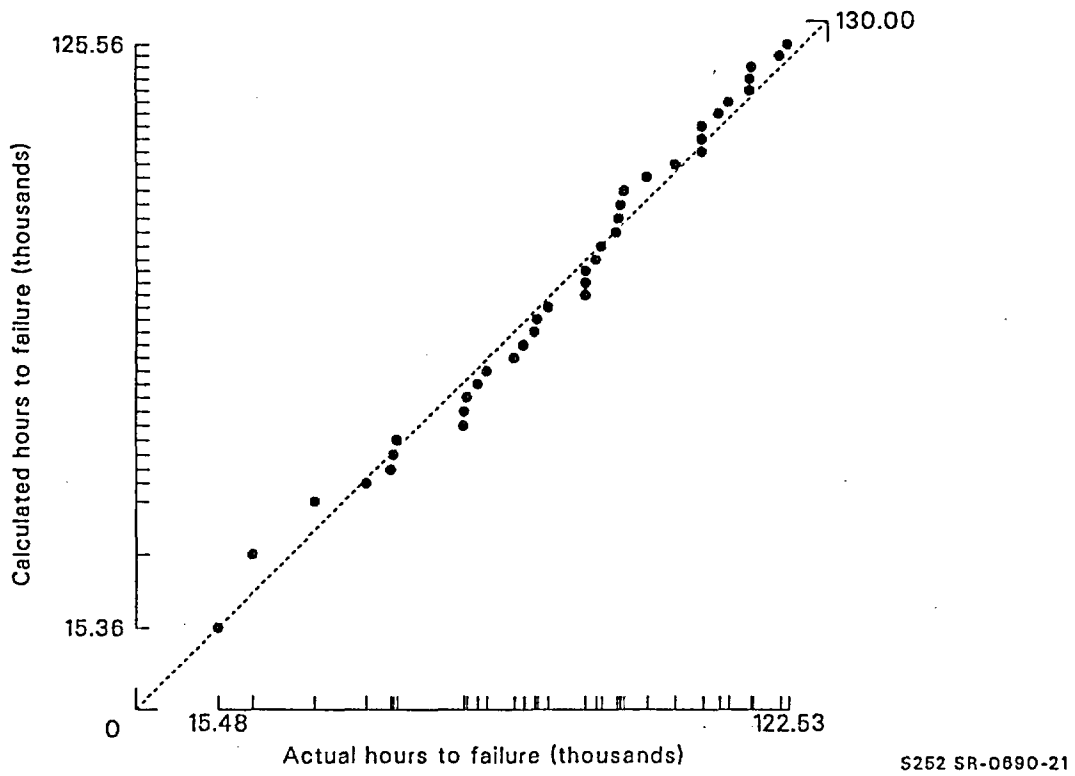
**Figure 6-2.** Q-Q plot for pump discharge check valves, broadly defined back leakage failures, exponential model, based on failures before the data were reinterpreted.



**Figure 6-3.** Q-Q plot for pump discharge check valves, broadly defined back leakage failures, Weibull model, based on failures before the data were reinterpreted.



**Figure 6-4.** Q-Q plot for pump discharge check valves, broadly defined back leakage failures, linear model, based on failures before the data were reinterpreted.



**Figure 6-5.** Q-Q plot for 3-in. MOVs (header isolation valves), broadly defined plugging failures, exponential model

Time-Dependent Failure Data Analysis

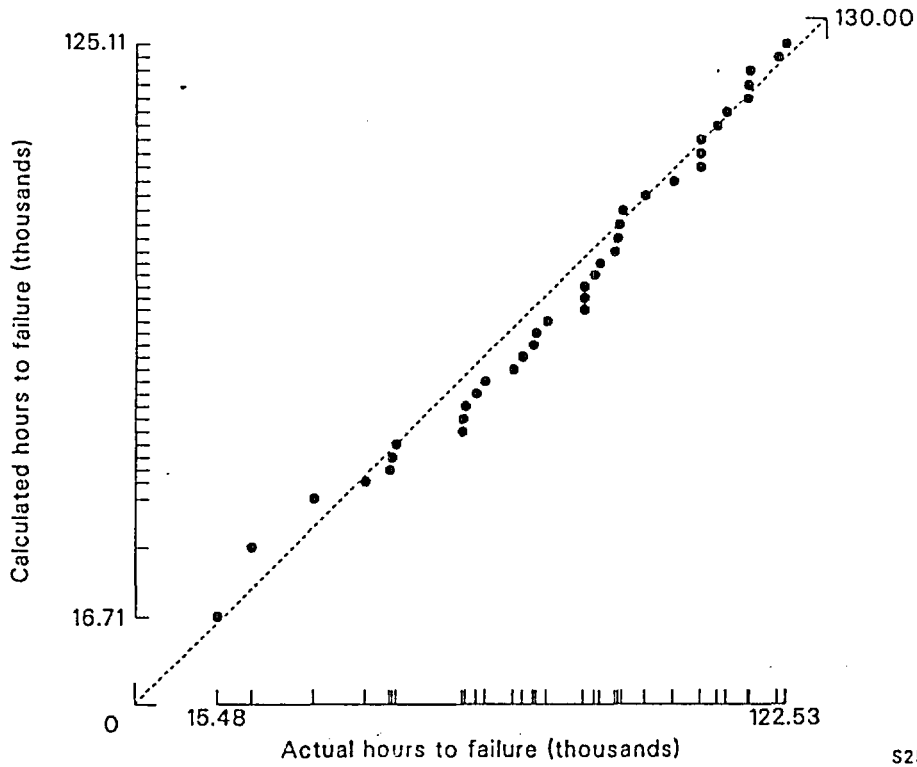


Figure 6-6. Q-Q plot for 3-in. MOVs (header isolation valves), broadly defined plugging failures, Weibull model.

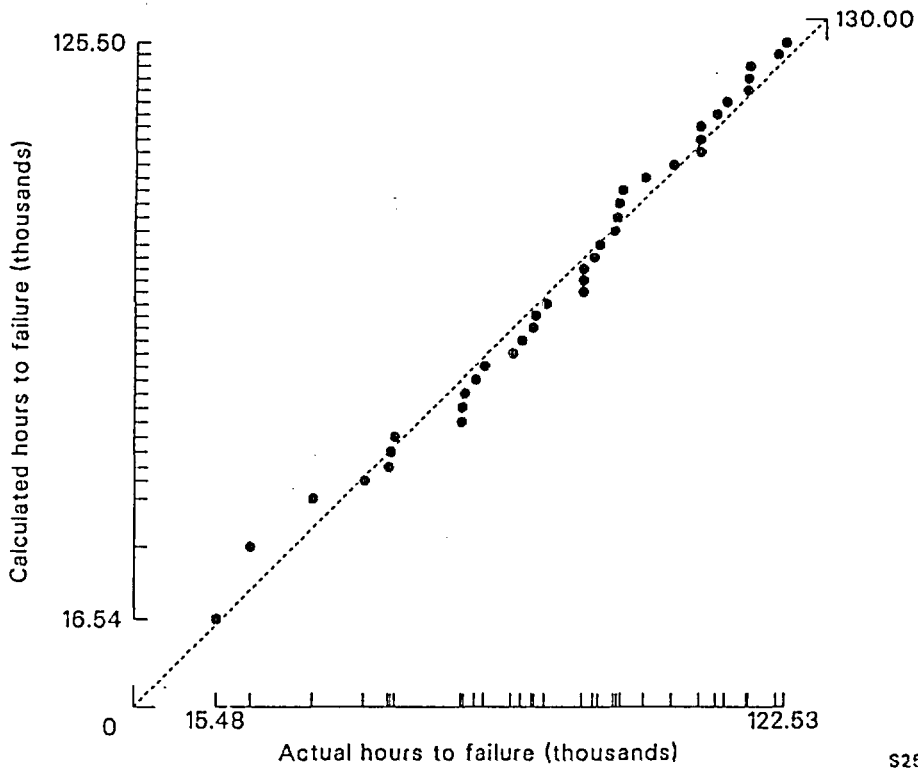
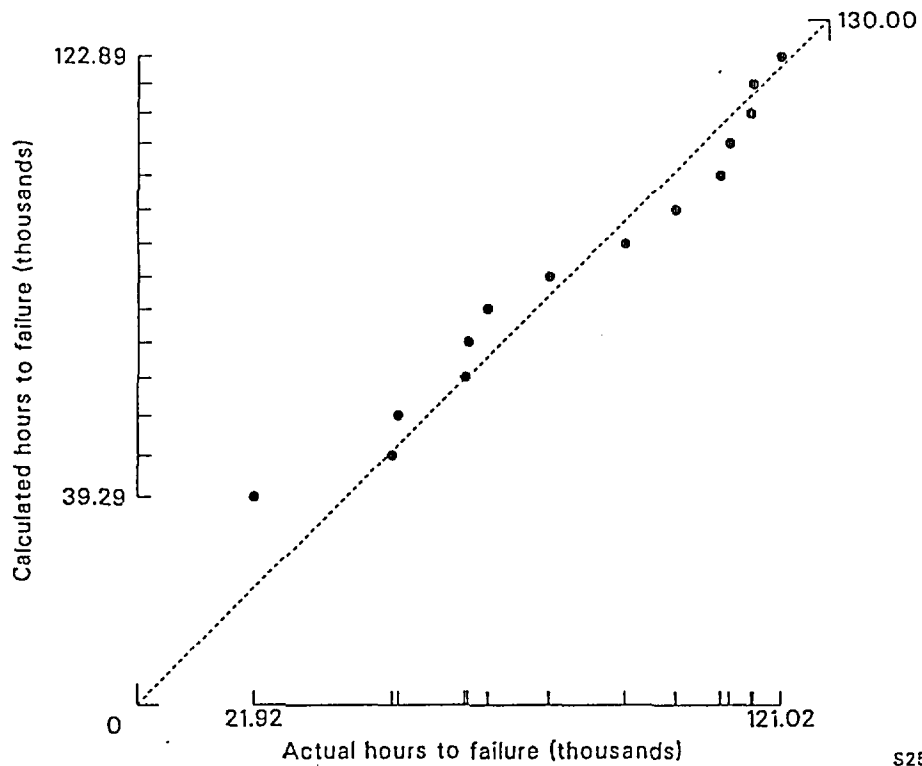


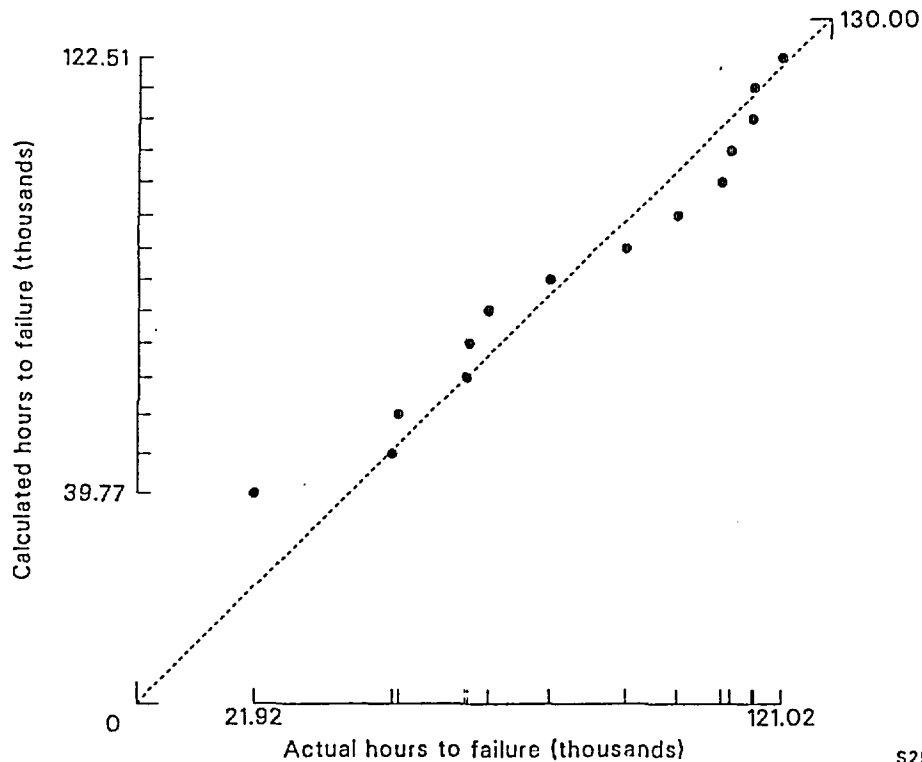
Figure 6-7. Q-Q plot for 3-in. MOVs (header isolation valves), broadly defined plugging failures, linear model.





S252 SR-0690-24

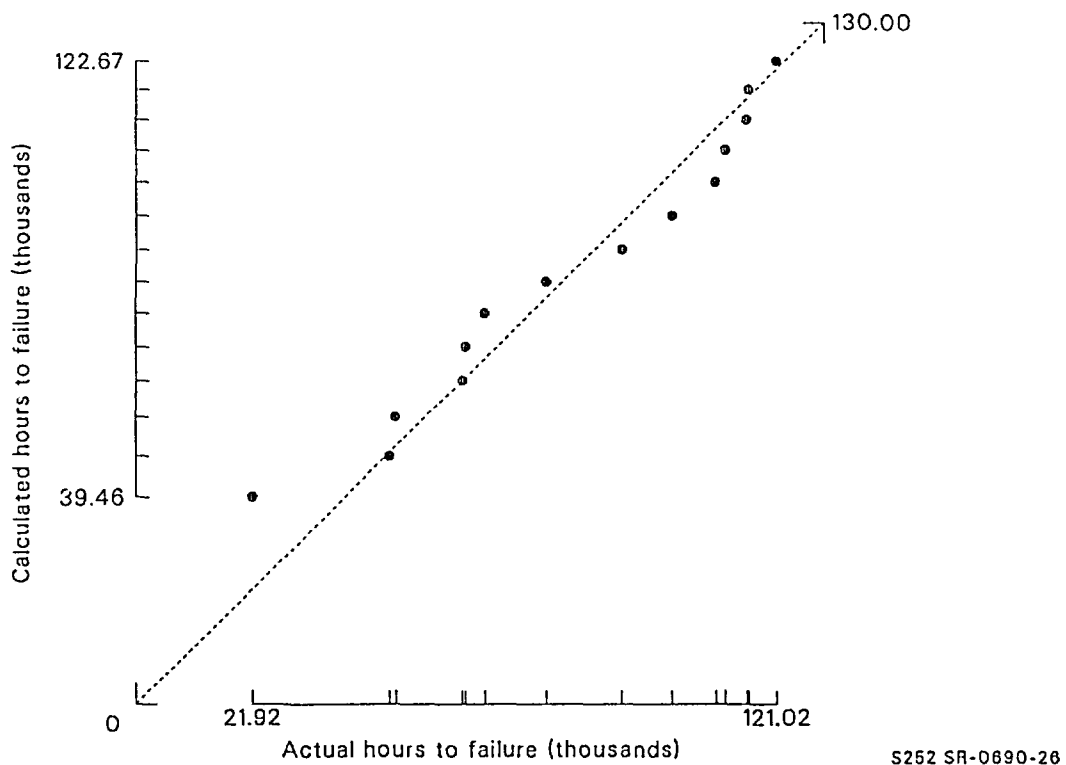
**Figure 6-8.** Q-Q plot for 3-in. MOVs (header isolation valves), narrowly defined plugging failures, exponential model.



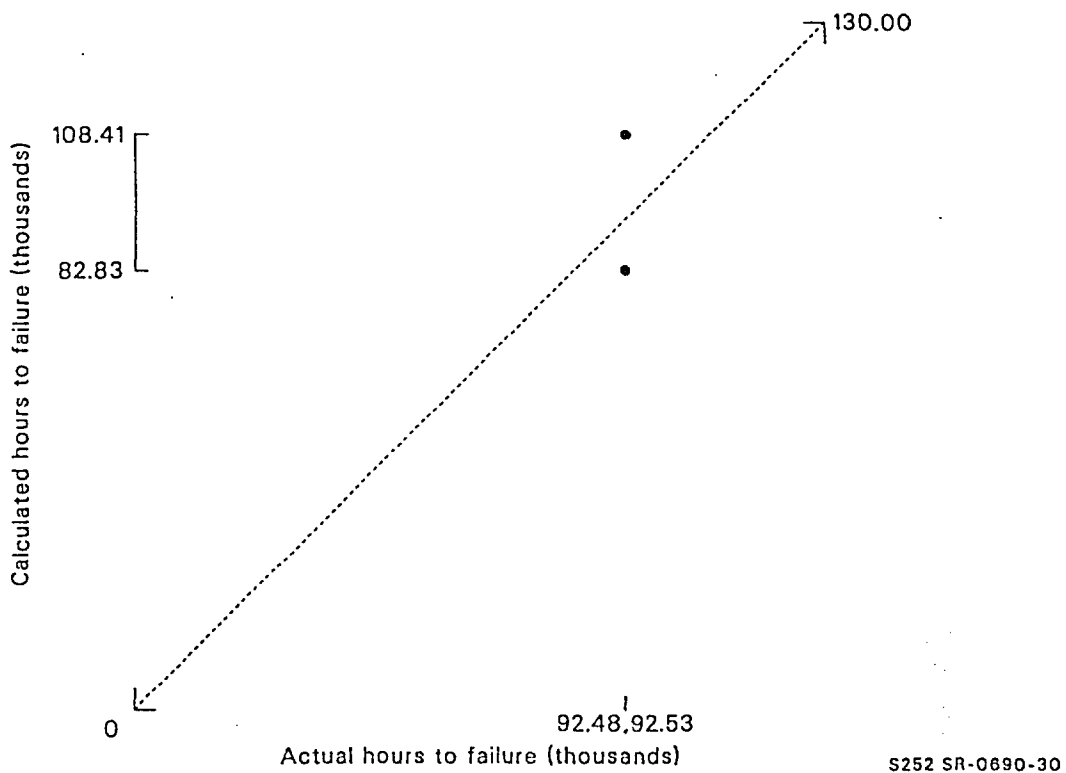
S252 SR-0690-25

**Figure 6-9.** Q-Q plot for 3-in. MOVs (header isolation valves), narrowly defined plugging failures, Weibull model.

# Time-Dependent Failure Data Analysis



**Figure 6-10.** Q-Q plot for 3-in. MOVs (header isolation valves), narrowly defined plugging failures, linear model.



**Figure 6-11.** Q-Q plot for either broadly or narrowly defined pump steam binding failures, exponential model.

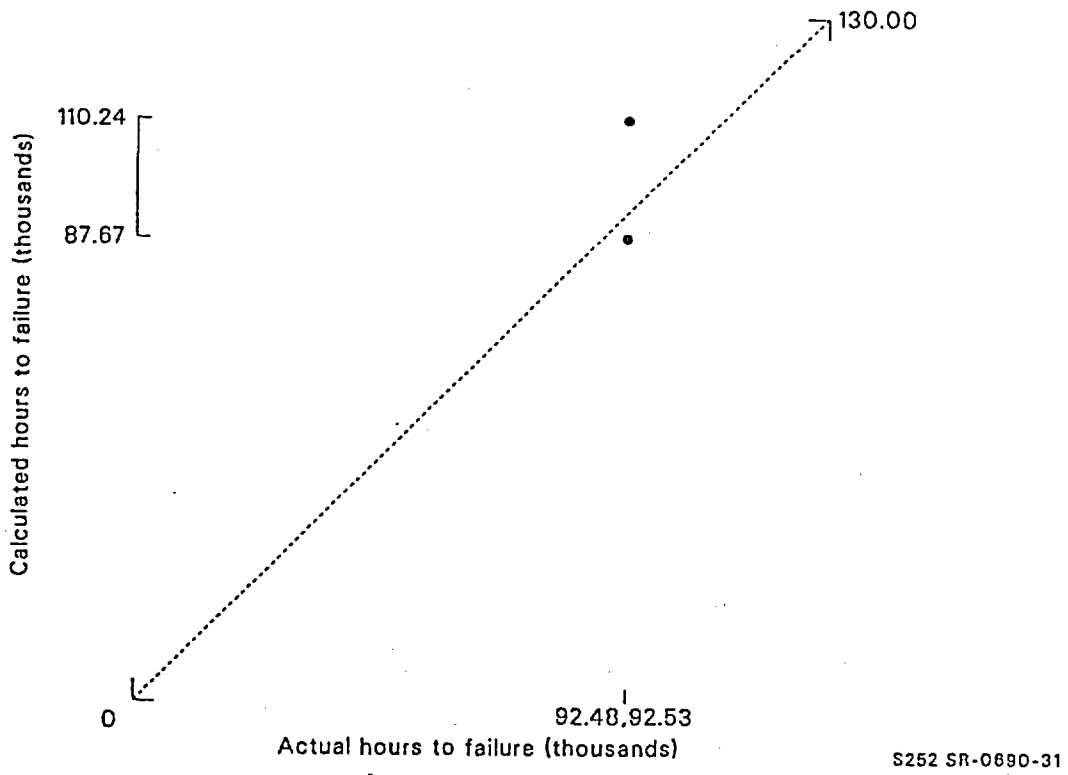


Figure 6-12. Q-Q plot for either broadly or narrowly defined pump steam binding failures, Weibull model.

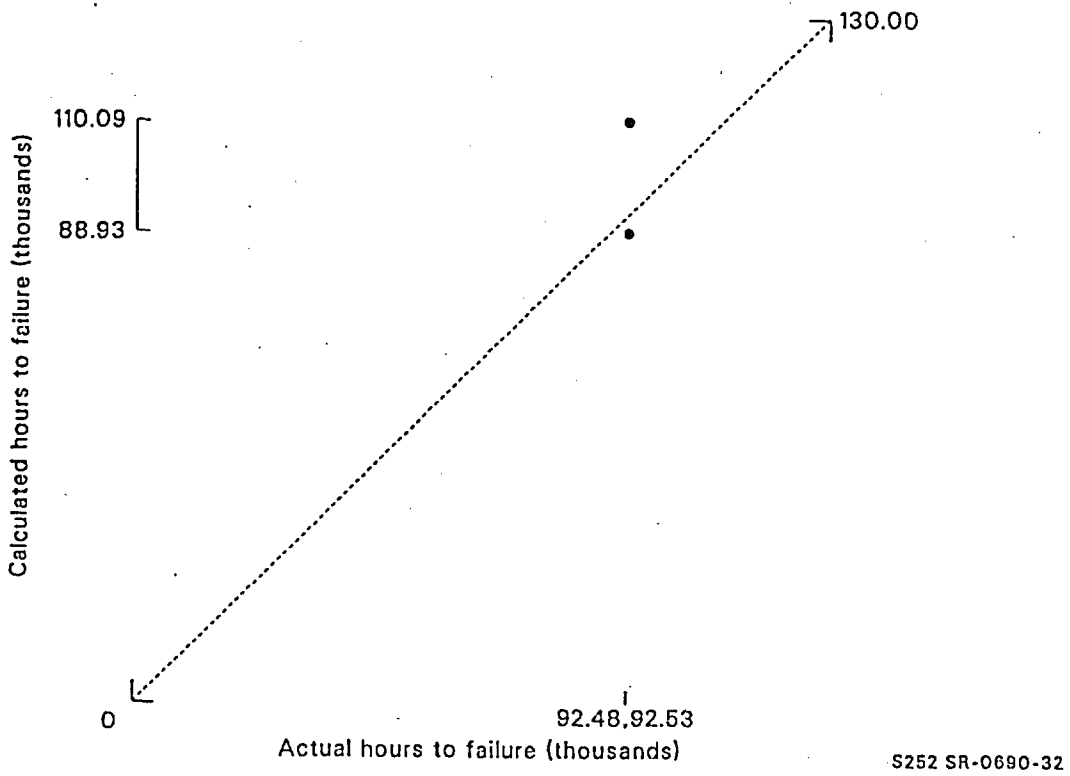


Figure 6-13. Q-Q plot for either broadly or narrowly defined pump steam binding failures, linear model.

## Time-Dependent Failure Data Analysis

true causes could not be established from the available maintenance records.

Because the lack of fit was at the borderline between acceptance and rejection (at the 0.05 significance level), the data were analyzed based on the assumed aging models. This decision was influenced by two considerations:

- Modeling the failure rate as increasing is conservative.
- Failures that cluster are not specifically a problem for aging models. They are a problem for any data analysis that is typically done for a PRA. In particular, the usual analysis assumes that the failures are independent with a constant failure rate; clustering violates the independence assumption. Thus, the lack of fit is present whether the check valves are treated as aging or not.

If this failure mode had had little effect on the risk, the issue would have been dropped. However, as discussed in Section 7, backflow of check valves turned out to be the dominant contributor to risk. Therefore, when review comments on a draft were received from personnel at the power station, we inquired specifically about the leakage failures.

The inquiry revealed three nearly simultaneous repairs of the pump discharge check valves at Unit 1 in May 1983 (see Figure 4-16 and Table 6-1). These repairs were made as a response to notification that leakage of check valves might be a generic, industry-wide problem. Indeed, some leakage was found, but the time of the onset of the leakage in each valve is unknown. The recurrent repairs of valve 2-CV-C were unsuccessful attempts to stop leakage that came from a different source, a failed orifice on a recirculation line, not through the check valve at all.

The most important discovery, however, was that none of the leakage events was severe enough to cause failure mode AFW-CKV-OO, backflow through the pump discharge check valve. (Recall that a maintenance record was classified as a fail-

ure under the broad definition if it was considered to possibly describe a failure, although it might only describe a problem that was fixed before the component had to be removed from service). Based on this additional knowledge, all the leakage events were reclassified as non-failures for the failure mode AFW-CKV-OO. The events were retained, however, for the steam binding failure mode (AFW-PMP-LK-STMBD) because minimal leakage is needed for that failure mode.

Therefore, the reinterpretation of the raw data eliminated AFW-CKV-OO as a failure mode affected by aging and left the calculations for AFW-PMP-LK-STMBD unchanged. After the reinterpretation, there was no problem with lack of fit to any of the aging models.

**6.2.4 Common  $\lambda_o$  Test for All Components Exhibiting Aging.** Next, the five component failure data sets that were determined to show time-dependent trends were analyzed to test the adequacy of the assumption that the data should be pooled based on equality of  $\lambda_o$  (Section 5.3.3). As for the equality test for  $\beta$ , if the significance level had been less than 0.05, then the significance levels and confidence interval plots associated with the component comparisons would have been visually checked for indication of an outlier, and engineering judgement would have been used to help decide whether to split the data. The assumption of pooling was found acceptable for all five data sets at significance levels ranging from 0.18 to 1.00, as shown in Tables 6-3 and 6-4. The confidence interval plot for  $\lambda_o$  for the 3-in. MOV plugging failure is shown in Figure 5-6.

**6.2.5 MLE for  $(\beta, \lambda_o)$ .** The MLEs for  $\beta$  and  $\lambda_o$  were found for the five component failure data sets that passed the screening to this point (Section 5.3.5). The results are shown by data set and assumed model in Table 6-5.

**6.2.6 Check of the Normal Approximation for Distribution of MLE.** The MLE is a point estimate only. To get a confidence band for  $\lambda(t)$ , it was assumed that the MLE  $(\hat{\beta}, \log \hat{\lambda}_o)$  had a bivariate normal distribution (Section 5.3.5). This assumption resulted in an approximately

**Table 6-5.** MLEs for  $\beta$  and  $\lambda_0$  by aging model and failure definition.

Failure mode	$\beta^a$			$\lambda^b$		
	Exponential	Weibull <sup>c</sup>	Linear <sup>c</sup>	Exponential	Weibull <sup>c</sup>	Linear <sup>c</sup>
<i>Broadly Defined Failures</i>						
AFW-MOV-PG	7.47E-06	0.312	7.66E-06	2.18E-05	3.97E-05	3.86E-05
AFW-PMP-LK-STMBD	1.34E-05	1.59	2.17E-05	1.16E-06	3.60E-06	3.76E-06
AFW-CKV-OO <sup>d</sup>	2.34E-05	2.37	2.17E-05	2.77E-06	1.96E-05	2.26E-05
<i>Narrowly Defined Failures</i>						
AFW-MOV-PG	9.07E-06	0.603	9.79E-06	7.92E-06	1.64E-05	1.60E-05
AFW-PMP-LK-STMBD	1.34E-05	1.59	2.17E-05	1.16E-06	3.6E-06	3.76E-06

a. Units are 1/hour under the exponential and linear models, and dimensionless under the Weibull model.

b. Units are 1/hour.

c. For the linear model the data were centered, that is, all times were measured from a point near the middle of the observation period ( $t_{mid}$ , defined in Section 4.3 of Appendix A.) For the Weibull model, the normalizing time  $t_0$  was set equal to this same  $t_{mid}$ .

d. Following discussion with personnel from the power station, the events with leakage of check valves were all reinterpreted as non-failures, and the failure mode AFW-CKV-OO was no longer regarded as affected by aging. See Section 6.2.3.

lognormal distribution for  $\hat{\lambda}(t)$ , which could then be used for PRA input. To check the adequacy of the bivariate normal assumption, a graphical comparison was made of the conservatively estimated confidence region and the confidence region based on the asymptotic normality assumption. The comparisons are shown in Figures 5-8 through 5-11 for 3-in. MOVs (AFW-MOV-PG) with broadly defined failures and in Figures 6-14 to 6-21 for the other data sets. No figure is shown for the linear model when  $\hat{\beta}$  was at the end of the allowed range; in those cases asymptotic normality did not hold. For all the failure sets, the assumption of approximate normality appeared good enough when the exponential or Weibull model was used. Approximate normality was clearly false with the linear model; much larger data sets would have been needed before the asymptotic normal distribution was approached.

For pump steam binding under the Weibull model (Figure 6-21), the confidence ellipse was truncated at the minimum allowed value of  $\beta = -1$ . This indicated that the normal approximation was not very good. The difficulty does not affect the upper bound for future  $\lambda(t)$ , however, and therefore was ignored.

### 6.3 Calculation of $\lambda(t)$ as a Function of Time

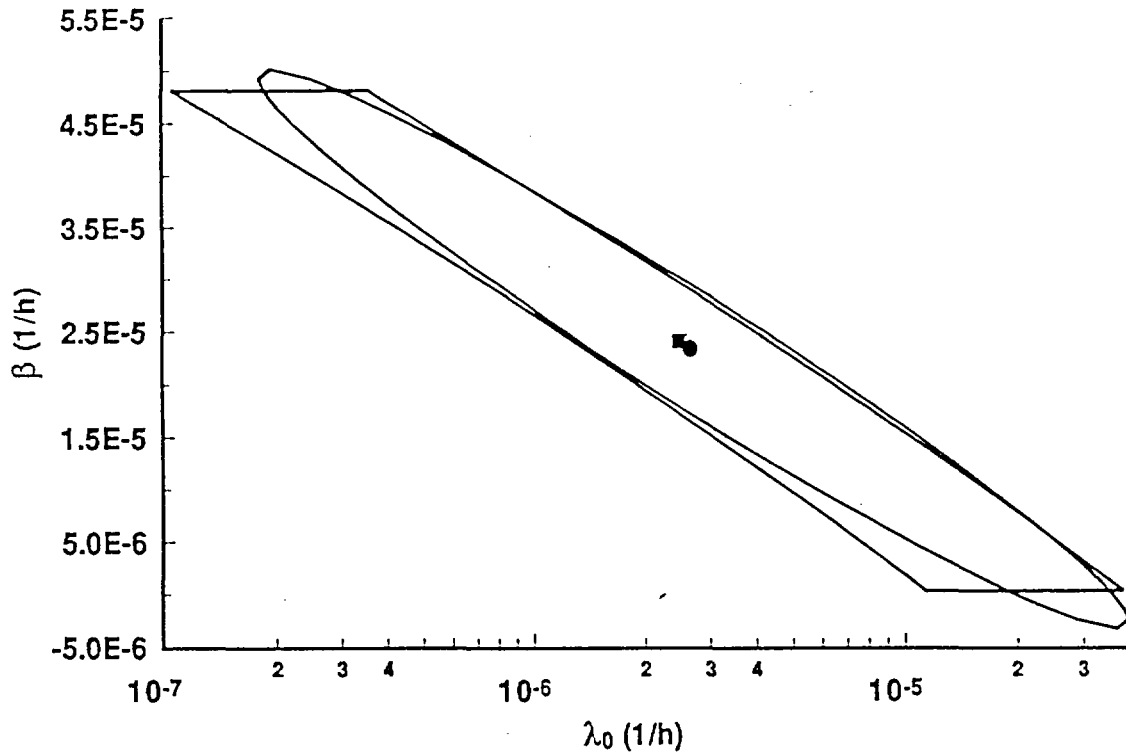
With the screening completed, the value of  $\lambda(t)$  and its associated confidence interval were calculated as a function of time for the five data sets

showing a time-dependent behavior (Section 5.3.5). The point estimate of  $\lambda(t)$  was calculated for all three models to allow comparison, but the confidence intervals were calculated for only the exponential and Weibull models because of the failure of the asymptotic normality assumption for the linear model. The results of the calculations are shown in Tables 6-6 to 6-8.

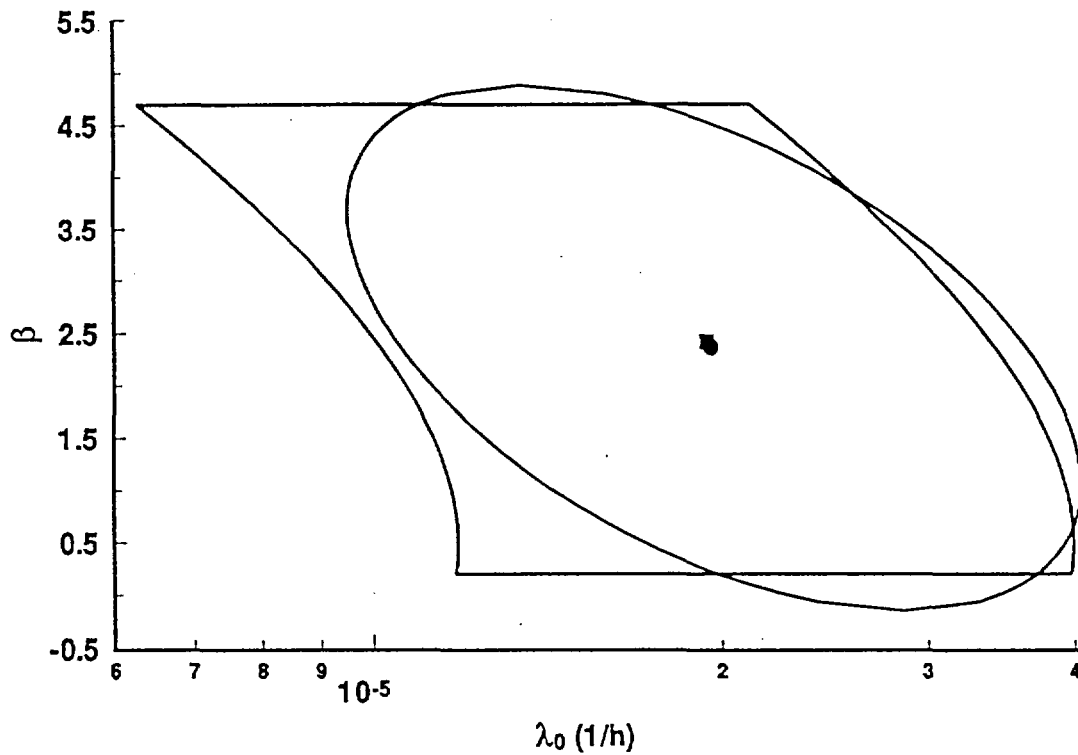
The year 1987 in these tables represents the value of  $\lambda$  at the "present" time, the time at which the data collection ceased. The years 1988, 1989, and 1990 represent the "future" and show the predicted value of  $\lambda$  based on the demonstrated trend. No values of  $\lambda$  were calculated further in the future because the unknown, but significant, effects of human interaction (mitigation) can drastically change the rate of aging.

### 6.4 Case Study Problem Specifications

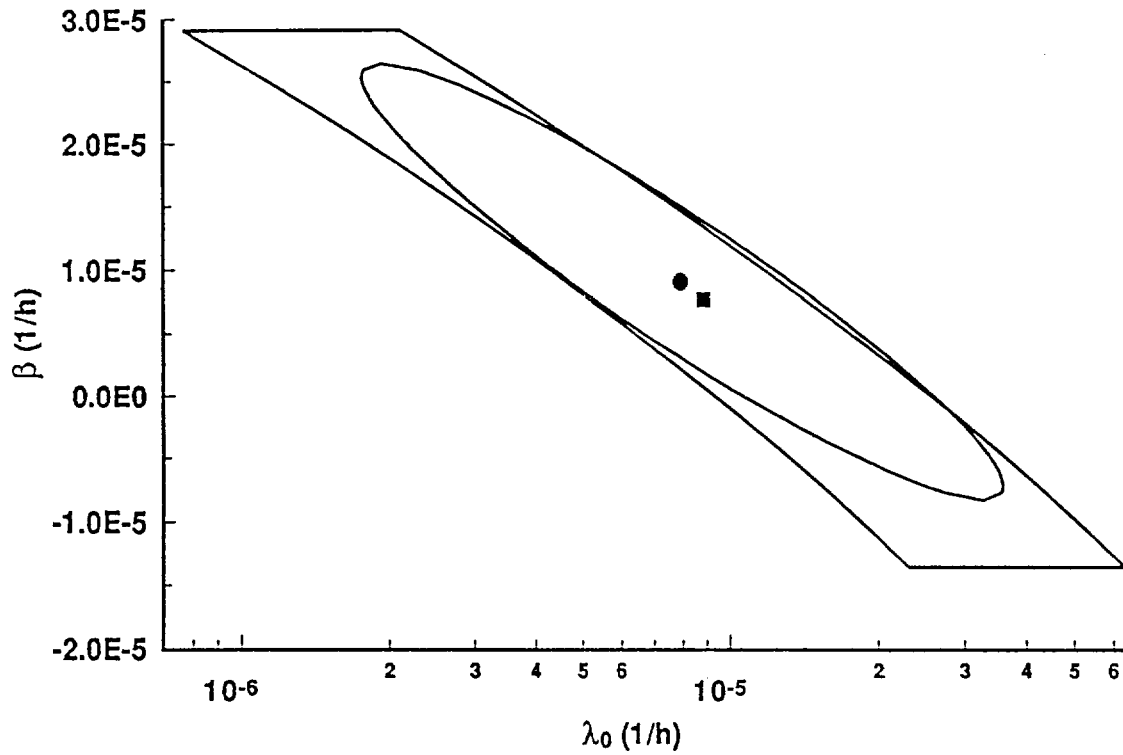
The results of all raw failure data collection, development, and analysis were used in the calculation of time-dependent plant risk. Numerous cases were analyzed in this work. Each case was a combination of the definition of failure (broad or narrow), the significance level at which the no-aging assumption was rejected (0.40 or 0.05), and the model employed (exponential, Weibull, or linear). Remember that only point estimates were possible for the linear model because the confidence interval on the MLE could not be calculated. The failure sets analyzed as a result of the different combinations are shown in Table 6-9.



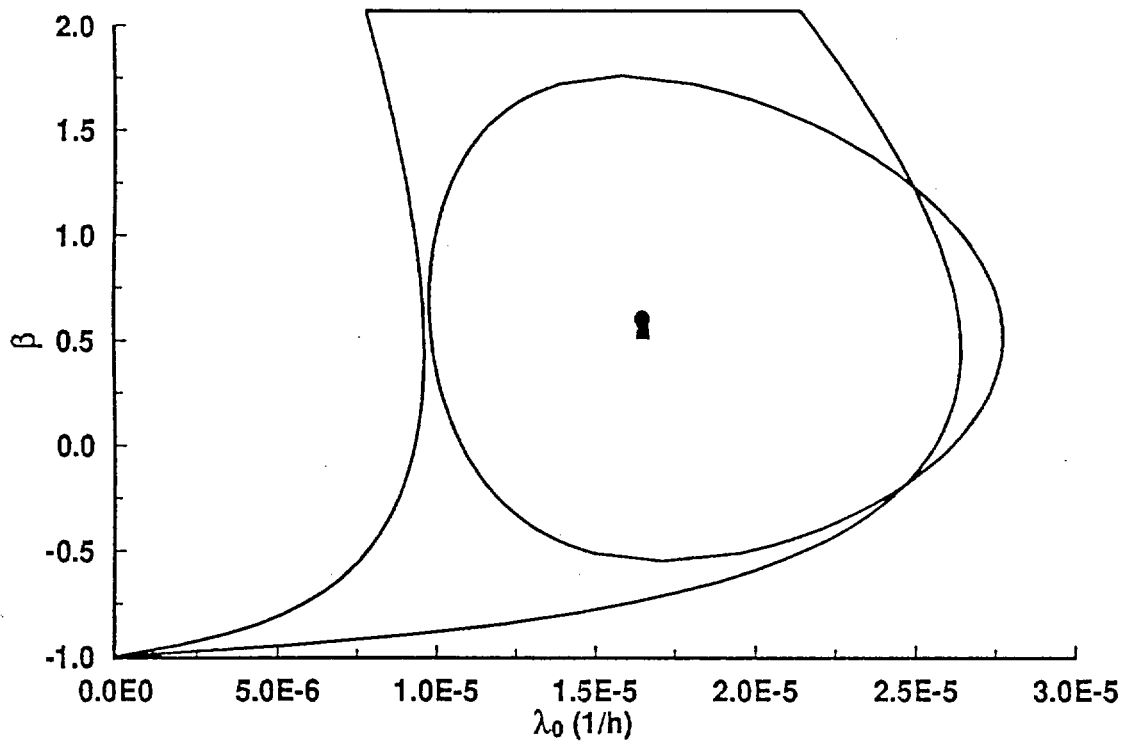
**Figure 6-14.** 90% confidence regions for  $(\beta, \lambda_0)$  for pump discharge check valves, broadly defined back leakage failures, exponential model, based on failures before the data were reinterpreted.



**Figure 6-15.** 90% confidence regions for  $(\beta, \lambda_0)$  for pump discharge check valves, broadly defined back leakage failures, Weibull model, based on failures before the data were reinterpreted.

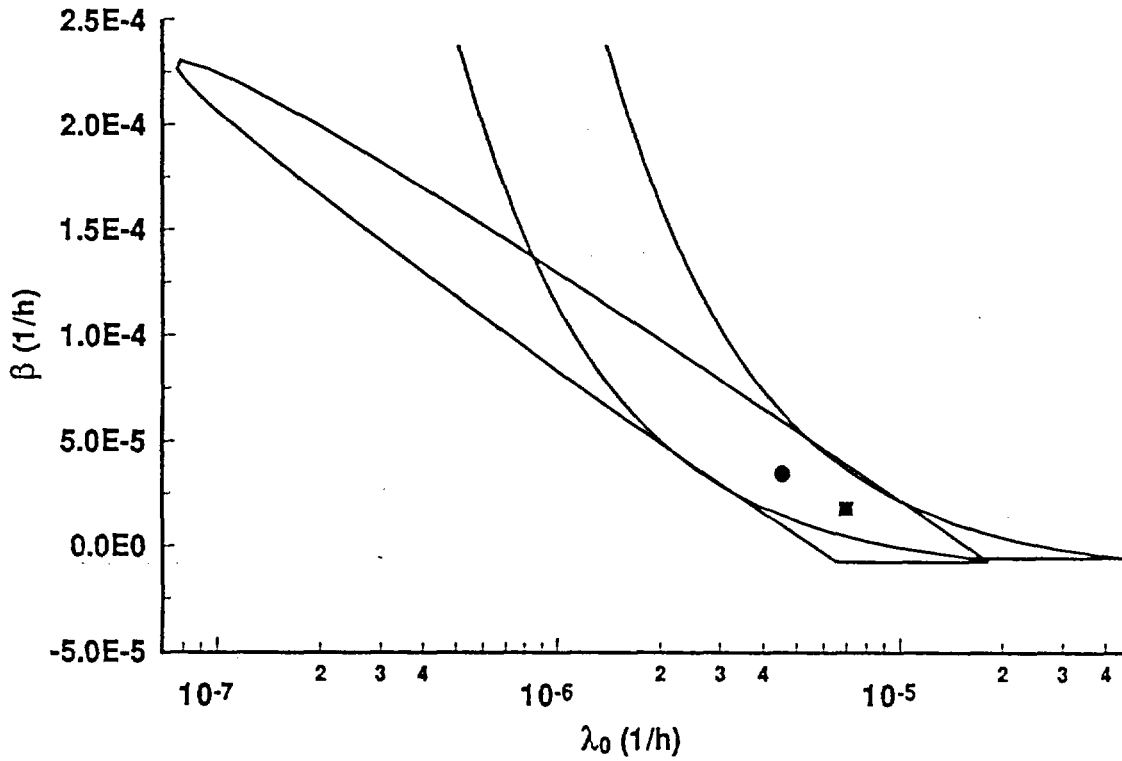


**Figure 6-16.** 90% confidence regions for  $(\beta, \lambda_0)$  for 3-in. MOVs (header isolation valves), narrowly defined plugging failures, exponential model.

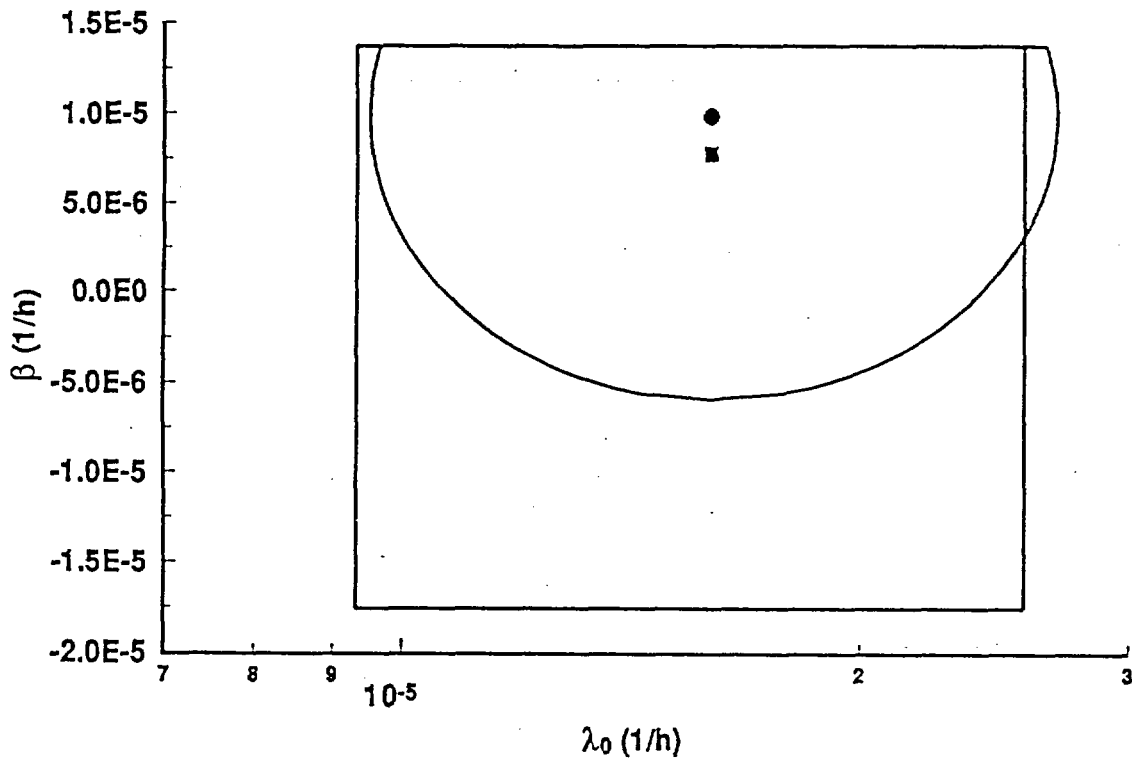


**Figure 6-17.** 90% confidence regions for  $(\beta, \lambda_0)$  for 3-in. MOVs (header isolation valves), narrowly defined plugging failures, Weibull model.





**Figure 6-18.** 90% confidence regions for  $(\beta, \lambda_0)$  for 3-in. MOVs (header isolation valves), narrowly defined plugging failures, linear model, time measured from component's installation.



**Figure 6-19.** 90% confidence regions for  $(\beta, \lambda_0)$  for 3-in. MOVs (header isolation valves), narrowly defined plugging failures, linear model, time measured from middle of observation periods.

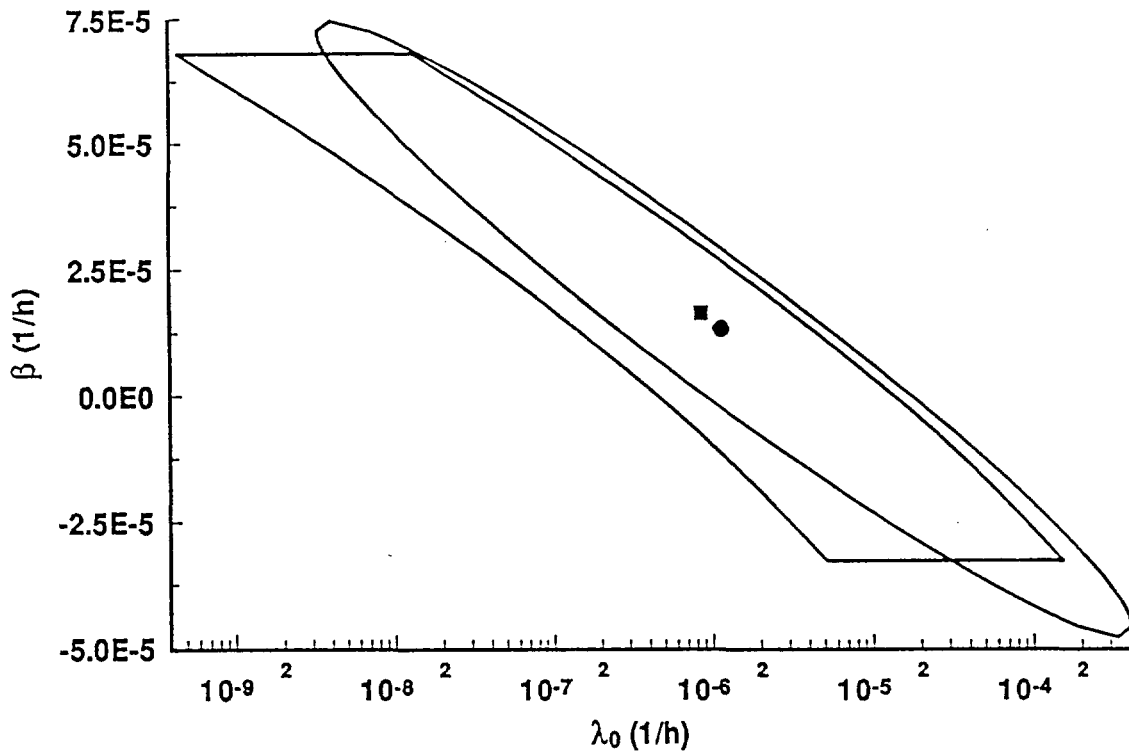


Figure 6-20. 90% confidence regions for  $(\beta, \lambda_0)$  for pump steam binding, broadly or narrowly defined failures, exponential model.

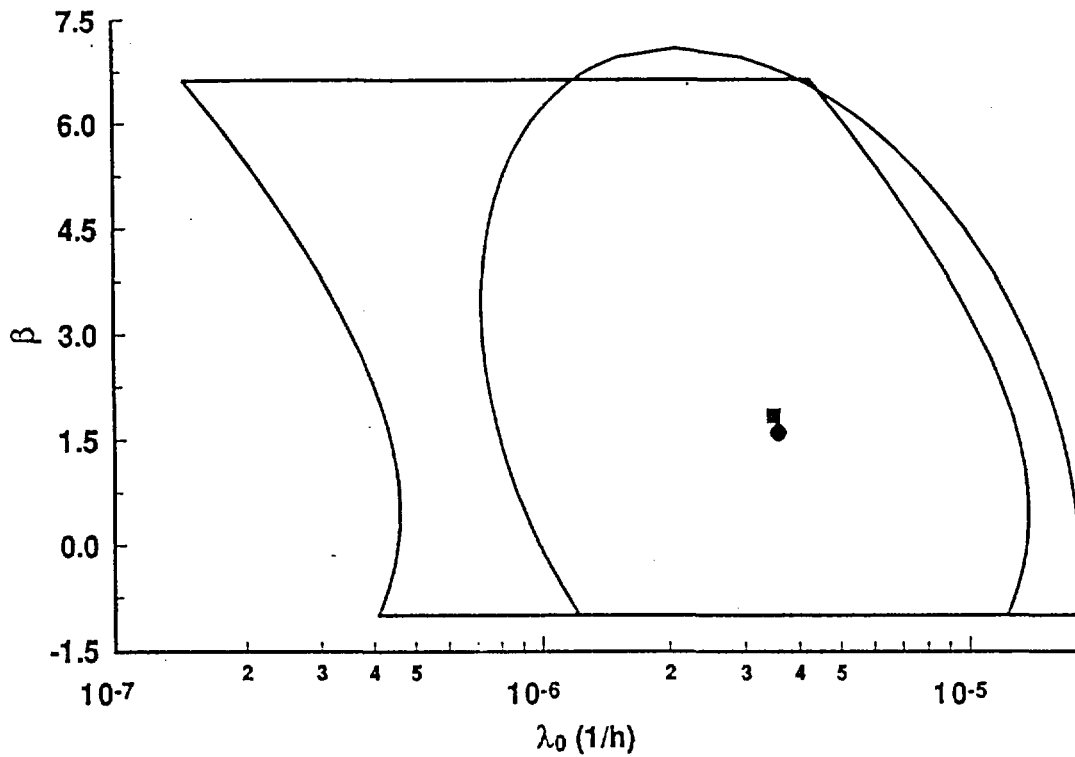


Figure 6-21. 90% confidence regions for  $(\beta, \lambda_0)$  for pump steam binding, broadly or narrowly defined failures, Weibull model.

**Table 6-6.** MLEs of  $\lambda(t)$  and associated confidence intervals by failure mode definition for the exponential model.

Failure mode	$\lambda(t)$ and confidence interval			
	1987	1988	1989	1990
<i>Broadly Defined Failures</i>				
AFW-MOV-PG	5.81E-05 3.50E-05 to 9.64E-05	6.20E-05 3.50E-05 to 1.10E-04	6.62E-05 3.50E-05 to 1.26E-04	7.07E-05 3.48E-05 to 1.44E-04
AFW-PMP-LK-STMBD	6.70E-06 7.66E-07 to 5.86E-05	7.53E-06 6.03E-07 to 9.42E-05	8.47E-06 4.67E-07 to 1.53E-04	9.52E-06 3.59E-07 to 2.53E-04
AFW-CKV-OO <sup>a</sup>	5.77E-05 2.52E-05 to 1.32E-04	7.08E-05 2.65E-05 to 1.89E-04	8.69E-05 2.77E-05 to 2.72E-04	1.07E-04 2.89E-05 to 3.94E-04
<i>Narrowly Defined Failures</i>				
AFW-MOV-PG	2.61E-05 1.20E-05 to 5.67E-05	2.83E-05 1.18E-05 to 6.80E-05	3.06E-05 1.15E-05 to 8.18E-05	3.32E-05 1.12E-05 to 9.86E-05
AFW-PMP-LK-STMBD	6.70E-06 7.66E-07 to 5.86E-05	7.53E-06 6.03E-07 to 9.42E-05	8.47E-06 4.67E-07 to 1.53E-04	9.52E-06 3.59E-07 to 2.53E-04

a. Following discussion with personnel from the power station, the events with backflow of check valves were all reinterpreted as non-failures, and the failure mode AFW-CKV-OO was no longer regarded as affected by aging. (See Section 6.2.3.) Therefore,  $\lambda(t)$  was taken to be the constant value given in the NUREG-1150 PRA.

**Table 6-7.** MLEs of  $\lambda(t)$  and associated confidence intervals by failure mode definition for the Weibull model.

Failure mode	$\lambda(t)$ and confidence interval			
	1987	1988	1989	1990
<i>Broadly Defined Failures</i>				
AFW-MOV-PG	4.76E-05 3.21E-05 to 7.07E-05	4.86E-05 3.20E-05 to 7.39E-05	4.95E-05 3.18E-05 to 7.71E-05	5.04E-05 3.17E-05 to 8.03E-05
AFW-PMP-LK-STMBD	7.37E-06 1.12E-06 to 4.83E-05	8.17E-06 9.99E-07 to 6.67E-05	8.99E-06 8.87E-07 to 9.12E-05	9.85E-06 7.87E-07 to 1.23E-04
AFW-CKV-OO <sup>a</sup>	5.68E-05 2.70E-05 to 1.20E-04	6.62E-05 2.84E-05 to 1.54E-04	7.64E-05 2.97E-05 to 1.96E-04	8.75E-05 3.09E-05 to 2.47E-04
<i>Narrowly Defined Failures</i>				
AFW-MOV-PG	2.34E-05 1.25E-05 to 4.40E-05	2.44E-05 1.24E-05 to 4.79E-05	2.53E-05 1.23E-05 to 5.19E-05	2.62E-05 1.22E-05 to 5.60E-05
AFW-PMP-LK-STMBD	7.37E-06 1.12E-06 to 4.83E-05	8.17E-06 9.99E-07 to 6.67E-05	8.99E-06 8.87E-07 to 9.12E-05	9.85E-06 7.87E-07 to 1.23E-04

a. Following discussion with personnel from the power station, the events with backflow of check valves were all reinterpreted as non-failures, and the failure mode AFW-CKV-OO was no longer regarded as affected by aging (Section 6.2.3). Therefore,  $\lambda(t)$  was taken to be the constant value given in the NUREG-1150 PRA.

**Table 6-8.** MLEs of  $\lambda(t)$  by failure mode definition for the linear model.

Failure mode	$\lambda(t)$			
	1987	1988	1989	1990
<i>Broadly Defined Failures</i>				
AFW-MOV-PG	5.58E-05	5.84E-05	6.10E-05	6.36E-05
AFW-PMP-LK-STMBD	7.65E-06	8.36E-06	9.08E-06	9.79E-06
AFW-CKV-OO <sup>a</sup>	4.59E-05	5.02E-05	5.45E-05	5.87E-05
<i>Narrowly Defined Failures</i>				
AFW-MOV-PG	2.51E-05	2.65E-05	2.79E-05	2.93E-05
AFW-PMP-LK-STMBD	7.65E-06	8.36E-06	9.08E-06	9.79E-06

a. Following discussion with personnel from the power station, the events with backflow of check valves were all reinterpreted as non-failures, and the failure mode AFW-CKV-OO was no longer regarded as affected by aging (Section 6.2.3). Therefore,  $\lambda(t)$  was taken to be the constant value given in the NUREG-1150 PRA.

**Table 6-9.** Failure sets analyzed as a function of failure definition and significance level.<sup>a</sup>

	Broadly defined failures	Narrowly defined failures
No-aging assumption rejected at significance level of 0.40	<ol style="list-style-type: none"> <li>1. 3-in. MOV plugging failure</li> <li>2. Pump failure due to steam binding</li> <li>3. Pump discharge check valve failure to close<sup>b</sup></li> </ol>	<ol style="list-style-type: none"> <li>1. 3-in. MOV plugging failure</li> <li>2. Pump failure due to steam binding</li> </ol>
No-aging assumption rejected at significance level of 0.05	<ol style="list-style-type: none"> <li>1. Pump discharge check valve failure to close<sup>b</sup></li> </ol>	None

a. All combinations of failure definitions and confidence intervals were analyzed using each of the three models (exponential, Weibull, and linear).

b. Following discussion with personnel from the power plant, this failure mode was no longer regarded as affected by aging. See Section 6.2.3.

## 7. QUANTIFICATION OF TIME-DEPENDENT RISK

### 7.1 Time-Dependent Risk Analysis for AFW System

The final step in the risk quantification was the calculation of CDF using a PRA model. The usual inputs to a PRA include the time-averaged failure rates for various failure modes. In order to calculate the time-dependent CDF associated with the aging of the AFW system, the time-dependent failure rates developed in previous chapters were substituted for the time-averaged values.

**7.1.1 Use of Maximum Likelihood Results to Define Bayesian Distributions.** The work of Section 6 resulted in point estimates and confidence intervals for  $\lambda(t)$ , the failure rate of a type of component at a specified time  $t$ . The MLE  $\hat{\lambda}(t)$  has a distribution that is approximately lognormal (Section 5.3.5). Plots were examined (Figures 5-8 through 5-11 and 6-14 through 6-21) to ensure that this lognormal approximation was acceptable with our data. Use of the lognormal distribution then yielded the approximate 90% confidence bands developed in Section 5 (Figure 5-12) and Section 6 (Tables 6-6 and 6-7).

The usual PRA techniques require a different input to the computer code, a Bayesian distribution for  $\lambda(t)$ . The conversion from a confidence interval to a Bayesian distribution was accomplished as follows. There is a Bayesian distribution that results in intervals that are numerically the same as the confidence intervals, but now with a Bayesian interpretation. That is, the 90% confidence interval equals a 90% interval given by the Bayesian density, the 95% confidence interval equals a 95% Bayesian interval, and so forth. This perfect agreement occurs if the Bayesian distribution is identical to the lognormal distribution for the MLE. Therefore, the required Bayesian distribution for  $\lambda(t)$  for an aging component was set equal to the distribution of  $\hat{\lambda}(t)$  calculated by PHAZE.

The usual textbook development of a Bayesian distribution assumes a prior distribution and

combines it with the data to yield a posterior distribution. For a sample application, see Bier et al. (1990). By contrast, the approach of this report does not use a prior distribution at all. One important reason is the difficulty in obtaining well-justified prior distributions for aging rates. For example, the widely cited TIRGALEX report (Levy et al. 1988, p. 2.19) presents aging rates, but states "it is the relative positioning of the components, not the absolute numerical values . . . [that are] important." The Bayesian distributions of the present report are based on the data alone because confidence intervals depend on the data alone. The results are as if the prior distributions corresponded to complete ignorance. This is a conservative approach, which has been advocated, for example, by Vaurio (1990).

**7.1.2 Resulting Time-Dependent Component Failure Rate Inputs.** The PRA model was solved using the IRRAS computer code (Russell et al. 1989). For lognormal inputs, IRRAS requires a mean failure rate and an error factor as failure mode inputs. This mean is somewhat larger than the median; the median is numerically equal to the MLE calculated by PHAZE.

Table 7-1 is a summary of these means and error factors by aging model, by failure definition, and by failure mode. The values were calculated for the time when data collection ceased in 1987 and for the three years following. As mentioned in Section 2.4, we do not recommend extending the aging rates further into the future because human interactions are unpredictable, unless possible mitigating actions are explicitly modeled.

For comparison, the time-dependent failure rates were also calculated for 1973 and 1974, as summarized in Table 7-1. The year 1973 is the initial operation date and can be used to calculate the initial CDF. The values are shown for one year later, 1974, to allow a useful comparison for the Weibull failure rate, because this rate is zero at time zero for any positive value of  $\beta$ . Also shown in Table 7-1 are the time-averaged failure rates

**Table 7-1.** Mean values of  $\lambda(t)$  and associated error factor<sup>a</sup> by failure definition and failure model.

Failure mode	Failure model	$\lambda(t)$ and error factor												
		NUREG-1150	1973	1974	1987	1988	1989	1990						
<i>Broadly Defined Failure</i>														
AFW-MOV-PG	Exponential		2.40E-05	2.1	2.52E-05	1.9	6.09E-05	1.66	6.59E-05	1.77	7.14E-05	1.89	7.76E-05	2.03
	Weibull	1.0E-07 3	N/A <sup>b</sup>		2.50E-05	2.8	4.90E-05	1.48	5.02E-05	1.52	5.14E-05	1.56	5.25E-05	1.59
	Linear		1.70E-05		1.96E-05		5.58E-05		5.84E-05		6.10E-05		6.36E-05	
AFW-PMP-STMBD	Exponential <sup>c</sup>		4.85E-05	89.7	2.91E-05	60.3	1.60E-05	8.74	2.44E-05	12.50	3.99E-05	18.12	6.93E-05	26.52
	Weibull	2.5E-05 30	N/A <sup>b</sup>		2.48E-05	69.4	1.42E-05	6.56	1.84E-05	8.17	2.42E-05	10.14	3.21E-05	12.52
	Linear		0.00		0.0		7.64E-06		8.36E-06		9.08E-06		9.79E-06	
AFW-CKV-OO <sup>d</sup>	Exponential		5.88E-06	7.9	6.36E-06	6.6	6.55E-05	2.29	8.46E-05	2.67	1.11E-04	3.13	1.46E-04	3.70
	Weibull	2.0E-06 3	N/A <sup>b</sup>		5.17E-06	105	6.29E-05	2.11	7.55E-05	2.33	9.01E-05	2.57	1.07E-04	2.83
	Linear		0.00		0.00		4.59E-05		5.02E-05		5.45E-05		5.87E-05	
<i>Narrowly Defined Failure</i>														
AFW-MOV-PG	Exponential		1.02E-05	3.2	1.05E-05	2.8	2.92E-05	2.17	3.26E-05	2.40	3.66E-05	2.67	4.13E-05	2.97
	Weibull	1.0E-07 3	N/A <sup>b</sup>		9.20E-06	7.0	2.52E-05	1.88	2.65E-05	1.97	2.78E-05	2.05	2.91E-05	2.14
	Linear		4.53E-06		5.91E-06		2.51E-05		2.65E-05		2.79E-05		2.93E-05	
AFW-PMP-STMBD	Exponential		4.85E-05	89.7	2.91E-05	60.3	1.60E-05	8.74	2.44E-05	12.50	3.99E-05	18.12	6.93E-05	26.52
	Weibull	2.5E-05 30	N/A <sup>b</sup>		2.48E-05	69.4	1.42E-05	6.56	1.84E-05	8.17	2.42E-05	10.14	3.21E-05	12.52
	Linear		0.00		0.00		7.64E-06		8.36E-06		9.08E-06		9.79E-06	

a. For the exponential and Weibull models, the mean and error factor are given. The mean is larger than the MLE calculated in Section 6. For the linear model, only the MLE is given, as explained in Section 6.3. The Weibull failure rate is undefined at time zero (1973). Units of  $\lambda$  are 1/hour.

b. The Weibull failure rate is either zero or undefined at the beginning of the component's life.

c. While point estimates (MLEs) for  $\lambda$  at time zero are always less than MLEs for  $\lambda$  at one year, the mean value may be larger because of a larger uncertainty at time zero.

d. The values shown are based on failures before the data were reinterpreted. Following discussion with personnel from the power station, the events with backflow of check valves were all reinterpreted as non-failures, and the failure mode AFW-CKV-OO was no longer regarded as affected by aging. (See Section 6.2.3.) The constant failure rate from the NUREG-1150 PRA was used.



taken from the NUREG-1150 PRA (USNRC 1989).

**7.1.3 PRA Adjustment to Allow Time-Dependent Risk Quantification.** The PRA, as loaded into IRRAS, was verified by regenerating the cutsets from the fault trees and event trees using the same truncation values as used in the original NUREG-1150 analysis. The cutsets generated by IRRAS matched those of NUREG-1150.

Changes were made to the PRA, in addition to the input, in order to account appropriately for those components that were aging. The most fundamental change was to include component failure modes that were exhibiting aging and had been truncated from the time-averaged analysis. This change was accomplished by completely reanalyzing the PRA using an extremely large value for the failure rate of the failure modes showing aging: pump steam binding, 3-in. MOV plugging, and pump discharge check valve back-flow. The top cutsets were then regenerated. The resulting cutsets included the originals and approximately 1,000 additional cutsets. Note, the additional 1,000 cutsets had been truncated from the original PRA because they made a negligible contribution. They were included in the age-dependent PRA because it was not known if they would make a contribution. This was not a change in the conceptual fault tree, only a change of detail in the computation.

These cutsets were used to calculate risk as a function of time by using the failure rates shown in Table 7-1. For example, in order to calculate the predicted risk associated with the exponential aging model in the year 1990 for the narrow definition of failure at the 0.40 level of aging significance, the inputs for 3-in. MOV plugging would be  $7.76E-05$  and 2.03, the inputs for pump steam binding would be set to  $6.93E-05$  and 26.52, and the inputs for all other failure modes would be set to the time-averaged values from the NUREG-1150 PRA.

**7.1.4 Results.** After the data were reinterpreted, as described in Section 6.2.3, the two failure modes affected by aging were (a) 3-in. MOV

plugging failure and (b) pump failure from steam binding, as given in Tables 6-9 and 7-1. The failure modes, though not the failure rates, were the same under both the broad and narrow definitions of failure. The aging was statistically significant at the 0.40 level, but not at the 0.05 level.

The calculated risks for the various cases are shown in Table 7-2. The risk is expressed as total CDF. The associated uncertainties were calculated by IRRAS with standard simulation techniques using Latin-Hypercube sampling. Remember that since the linear model was unable to produce a distribution, an uncertainty or a mean for this model could not be produced.

Figure 7-1 is a graphical plot of the values from Table 7-2 corresponding to the broad definition of failure. The figure shows the mean and 90% interval for the CDF, assuming the exponential or Weibull model. For the linear model, the figure shows only the point estimate of the CDF, based on MLEs, because uncertainty intervals were not calculated for the linear model. The calculated CDF is shown for three years: the initial year of commercial operation, 1973; the following year, 1974; and the year when data collection ceased, 1987. The predicted CDF is shown for the three following years, 1988 to 1990. Also shown is the CDF taken from the NUREG-1150 PRA, a time averaged value.

The striking feature of Figure 7-1 is that the "aging" CDF is virtually constant, negligibly different from the steady-state values of the NUREG-1150 PRA. The increases in the two component failure rates have almost no effect on the overall CDF. Although not shown, a figure based on the narrow definition of failures would be very similar to Figure 7-1.

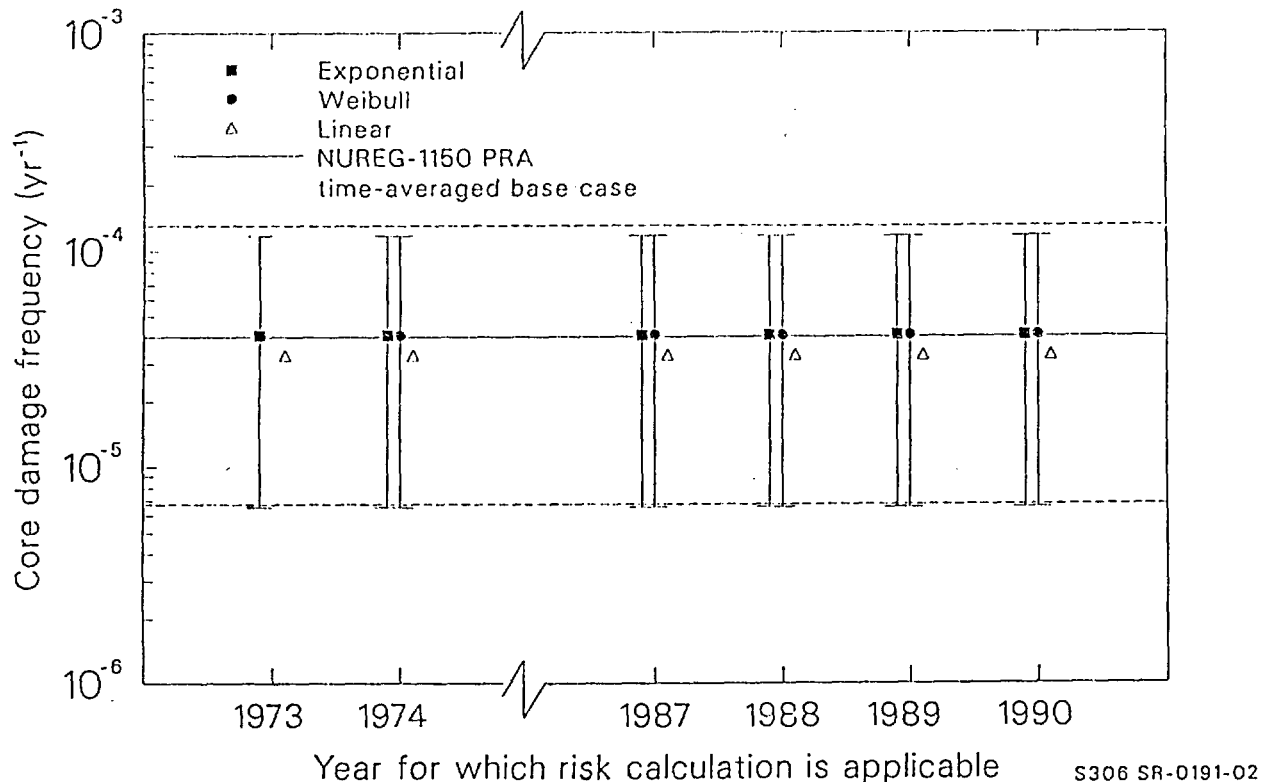
This report is primarily a demonstration of an approach, not a presentation of plant-specific results. Therefore, it is worth dwelling on some of the intermediate steps that led to Figure 7-1. Initially, pump discharge check valve failure-to-close was considered to exhibit statistically significant aging, as shown in Tables 6-9 and 7-1, when the broad definition of failure was used.

**Table 7-2.** Mean values of CDF and associated uncertainties quantified after reinterpretation of raw data.

Significance level <sup>a</sup>	Failure model	Mean value CDF (yr <sup>-1</sup> ) and 90% interval <sup>b</sup>					
		1973	1974	1987	1988	1989	1990
<i>Broadly Defined Failure</i>							
0.40	Exponential	4.09E-05	4.09E-05	4.09E-05	4.09E-05	4.09E-05	4.09E-05
		6.55E-06 to 1.18E-04	6.55E-06 to 1.18E-04	6.55E-06 to 1.18E-04	6.55E-06 to 1.18E-04	6.55E-06 to 1.18E-04	6.55E-06 to 1.18E-04
	Weibull	N/A	4.09E-05	4.09E-05	4.09E-05	4.09E-05	4.09E-05
			6.55E-06 to 1.18E-04	6.55E-06 to 1.18E-04	6.55E-06 to 1.18E-04	6.55E-06 to 1.18E-04	6.55E-06 to 1.18E-04
	Linear	3.30E-05	3.30E-05	3.30E-05	3.30E-05	3.30E-05	3.30E-05
<i>Narrowly Defined Failure</i>							
0.40	Exponential	4.09E-05	4.09E-05	4.09E-05	4.09E-05	4.09E-05	4.09E-05
		6.55E-06 to 1.18E-04	6.55E-06 to 1.18E-04	6.55E-06 to 1.18E-04	6.55E-06 to 1.18E-04	6.55E-06 to 1.18E-04	6.55E-06 to 1.18E-04
	Weibull	N/A	4.09E-05	4.09E-05	4.09E-05	4.09E-05	4.09E-05
			6.55E-06 to 1.18E-04	6.55E-06 to 1.18E-04	6.55E-06 to 1.18E-04	6.55E-06 to 1.18E-04	6.55E-06 to 1.18E-04
	Linear	3.30E-05	3.30E-05	3.30E-05	3.30E-05	3.30E-05	3.30E-05

a. There were no failure modes that rejected the no-aging assumption at the 0.05 level of significance.

b. Uncertainties could not be calculated for the linear model; therefore, only point estimates are given.



**Figure 7-1.** Calculated mean CDF and 90% interval after the data were reevaluated. Note that the Weibull failure rate is undefined at time zero (1973) and that for the linear model the MLEs are plotted because means could not be calculated.

Although the checks for fit of the model cast strong doubt on the assumption of independent failures, the failure rate for this failure mode was tentatively modeled as increasing, pending receipt of further information about the events recorded in the data base. This led to the data in Table 7-3 and Figure 7-2, in which the CDF is predicted to increase by a factor of about 2 in 17 years of plant operation. This increase results entirely from backflow of pump discharge check valves, which has a calculated failure rate of about 1 per year at the end of the time period. Such a failure rate is contrary to experience.

Although Figure 7-2 was eventually discarded in favor of Figure 7-1, the following observations apply to both figures.

- The mean and 90% interval of the total CDF is essentially the same regardless of whether the exponential or the Weibull model is used.

- The point estimate of CDF produced by the linear model is similar to the mean calculated using the other two models.
- The initial CDFs calculated from the time-dependent failure rates are consistent with the CDF from the PRA.

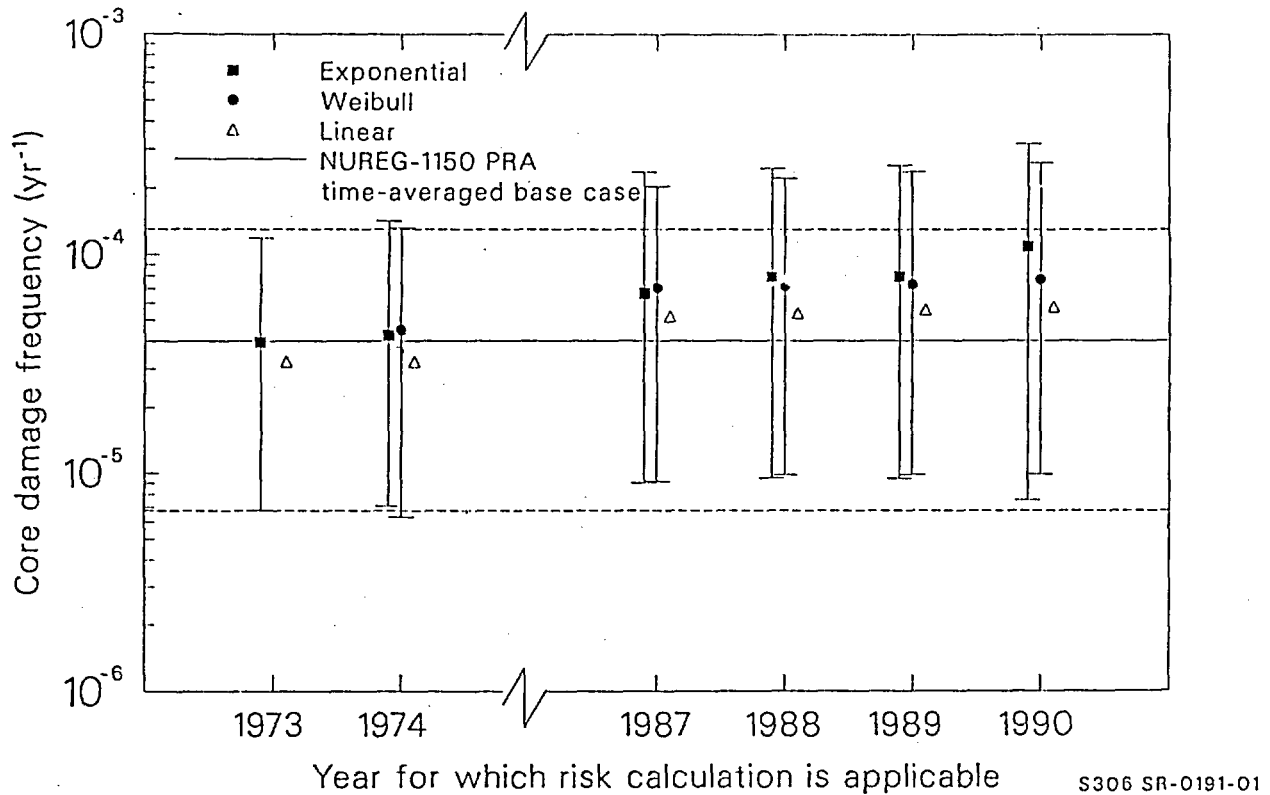
**7.1.5 Simultaneous Aging.** Caution must be used in applying the approach to be sure the interaction of the aging of components is considered. If the increase in CDF is calculated separately for the aging of each component, the sum of the change in CDF will underestimate the change with all components aging simultaneously. This occurs because the aging interaction will not be included. The concept can be demonstrated by a simple example of a two-component cutset with both components aging. If  $p_1$  and  $p_2$  are the initial failure probabilities and  $\Delta p_1$  and  $\Delta p_2$  are the increases in failure probabilities from aging, then the increase in failure probability of the cutset from aging calculated as the sum of the increase

**Table 7-3.** Mean values of CDF and associated uncertainties quantified before reinterpretation of raw data.

Significance level <sup>a</sup>	Failure model	Mean value CDF (yr <sup>-1</sup> ) and 90% interval <sup>b</sup>					
		1973	1974	1987	1988	1989	1990
<i>Broadly Defined Failure</i>							
0.40	Exponential	3.97E-05	4.25E-05	6.64E-05	7.87E-05	7.92E-05	1.09E-04
		6.79E-06 to 1.19E-04	7.08E-06 to 1.43E-04	9.02E-06 to 2.37E-04	9.47E-06 to 2.47E-04	9.45E-06 to 2.55E-04	7.53E-06 to 3.19E-04
	Weibull	N/A	4.51E-05	7.02E-05	7.17E-05	7.29E-05	7.70E-05
			6.31E-06 to 1.33E-04	9.14E-06 to 2.04E-04	9.81E-06 to 2.23E-04	9.81E-06 to 2.39E-04	9.85E-06 to 2.61E-04
	Linear	3.22E-05	3.22E-05	5.21E-05	5.39E-05	5.58E-05	5.75E-05
0.05	Exponential	3.97E-05	4.25E-05	6.64E-05	7.87E-05	7.92E-05	1.09E-04
		6.79E-06 to 1.19E-04	7.08E-06 to 1.43E-04	9.02E-06 to 2.37E-04	9.47E-06 to 2.47E-04	9.45E-06 to 2.55E-04	7.53E-06 to 3.19E-04
	Weibull	N/A	4.51E-05	7.02E-05	7.17E-05	7.29E-05	7.70E-05
			6.31E-06 to 1.33E-04	9.14E-06 to 2.04E-04	9.81E-06 to 2.23E-04	9.81E-06 to 2.39E-04	9.85E-06 to 2.61E-04
	Linear	3.22E-05	3.22E-05	5.21E-05	5.39E-05	5.58E-05	5.75E-05
<i>Narrowly Defined Failure</i>							
0.40	Exponential	4.09E-05	4.09E-05	4.09E-05	4.09E-05	4.09E-05	4.09E-05
		6.55E-06 to 1.18E-04	6.55E-06 to 1.18E-04	6.55E-06 to 1.18E-04	6.55E-06 to 1.18E-04	6.55E-06 to 1.18E-04	6.55E-06 to 1.18E-04
	Weibull	N/A	4.09E-05	4.09E-05	4.09E-05	4.09E-05	4.09E-05
			6.55E-06 to 1.18E-04	6.55E-06 to 1.18E-04	6.55E-06 to 1.18E-04	6.55E-06 to 1.18E-04	6.55E-06 to 1.18E-04
	Linear	3.30E-05	3.30E-05	3.30E-05	3.30E-05	3.30E-05	3.30E-05

a. There were no narrowly defined failures that rejected the no-aging assumption at the 0.05 level of significance.

b. Uncertainties could not be calculated for the linear model, therefore only point estimates are given.



**Figure 7-2.** Calculated mean CDF and 90% interval before the data were reevaluated. Note that the Weibull failure rate is undefined at time zero (1973) and that for the linear model the MLEs are plotted because means could not be calculated.

in failure probabilities with the components aging separately is

$$\begin{aligned}
 & [p_1(p_2 + \Delta p_2) - p_1 p_2] \\
 & + [(p_1 + \Delta p_1)p_2 - p_1 p_2] \\
 & = p_1 \Delta p_2 + p_2 \Delta p_1 \quad (7-1)
 \end{aligned}$$

However, the *change* in failure probability calculated with the components aging simultaneously is

$$\begin{aligned}
 & [(p_1 + \Delta p_1)(p_2 + \Delta p_2)] - p_1 p_2 \\
 & = p_1 \Delta p_2 + p_2 \Delta p_1 + \Delta p_1 \Delta p_2 \quad (7-2)
 \end{aligned}$$

Obviously, the calculation with the components aging separately does not include the interaction term  $\Delta p_1 \Delta p_2$ . Of course, for cutsets with more components there will be more interaction terms that are not included. If the increases in failure probabilities from aging are small, the aging interactions will be products of small numbers and will not be significant. However, if the increases in failure probabilities from aging are comparable to those of the retained cutsets, the

aging interactions will be important. Therefore, to accurately calculate the increase in CDF when the aging interactions are important, the increase in failure probabilities for all aging components should be included simultaneously in the PRA.

An objective of the research for this project was to demonstrate the approach by calculating the increase in CDF from the aging of components in a single system. Therefore, the demonstration in this section calculates the CDF if only the AFW system ages. For the demonstration case, only a few components were shown to be aging. Increases in failure probabilities of these components were input simultaneously and their mutual interactions were included. However, the terms for the interaction of aging with the aging of components in other systems were not included, and therefore, the effects of the interaction were not evaluated for the demonstration study.

The above reasoning may also be applied to systems rather than components. Of the sequences leading to core damage and involving

the AFW system, the vast majority involve simultaneous unavailability of the AFW system and other safety systems. Simultaneous unavailability of two systems corresponds to a "system-level cutset," in contrast to the usual component-level cutset. Equations (7-1) and (7-2) can be applied to the system-level cutsets by letting  $p$  denote the probability that a system is unavailable, and letting  $\Delta p$  be the change in this probability that results from aging. Although we argued above that everything should be treated as aging simultaneously, this report considered aging in only one system, the AFW system. However, the calculated effect of AFW aging was very small; in Equation (7-1),  $p_{\text{others}}\Delta p_{\text{AFW}}$  is very small, so  $\Delta p_{\text{AFW}}$  must be small. Therefore, either  $\Delta p_{\text{others}}$  is small, in which case the interaction term is very small, or  $\Delta p_{\text{others}}$  is moderate or large, in which case the interaction term is much less than the noninteraction term  $p_{\text{AFW}}\Delta p_{\text{others}}$ . In either case, the calculated aging of the AFW system would have little effect on CDF, even if all the systems in the plant were treated as aging simultaneously.

In summary, an aging analysis normally requires simultaneous consideration of aging of all components in all systems. In this particular case, when only aging in the AFW system was considered, the effect on CDF was extremely small. This shows that, even if aging of other systems were considered simultaneously, the interaction terms would be small and aging of the AFW system would have a very small effect. If the effect of aging of the one system had not been so small, it would have been necessary to consider simultaneous aging of the other systems as well.

## 7.2 Potential Applications

**7.2.1 Extrapolation to Distant Future.** The risk quantification approach presented in the preced-

ing section has not accounted explicitly for mitigating or corrective actions. Therefore, as discussed in Section 2.4, the methodology presented here is only useful for predicting risk for a few years in the future. Maintenance and replacement are treated implicitly as part of the environment for observed past failures and, therefore, also for extrapolations to the future. Schemes may be developed for future applications, such as the use of periodic replacement intervals to reset the time-dependent failure rate to the time-zero value (see Vesely et al. 1990) and/or the use of component replacement when the failure rate reaches a predetermined maximum allowed level.

### 7.2.2 Periodic Risk-Based Management.

Another option is to apply the approach on a yearly basis. This results in current risk knowledge with a small expenditure of effort. If such an analysis shows that the present or near-future calculated CDF is substantially greater than the time-averaged CDF from the PRA, the components or systems causing the increase should be identified. These components or systems could then be considered for increased surveillance, maintenance, and/or engineering analysis.

This approach was applied to the AFW data of this study for the years 1979 through 1987. For each year, only the data available at that time were analyzed. For example, the 1982 analysis used the data from 1978 through 1982. These analyses, based on the narrow definition of failure, showed possible aging problems in three of the years. None of these problems persisted year after year. This observation indicates that either (a) the trends identified were not actually present, but were false alarms, or (b) the maintenance programs in place for the AFW system successfully detected and mitigated the significant aging that was occurring.

## 8. CONCLUSIONS

The objectives of this study were as follows:

- Develop a way to identify and quantify age-dependent failure rates of active components and to incorporate them into PRA.
- Demonstrate this approach by applying it, with plant-specific data, to a fluid-mechanical system using the key elements of a NUREG-1150 PRA.
- Present it as a step-by-step approach, so that others can use it for evaluating the significance of risk from aging phenomena in systems of interest.

These objectives have been met. Several conclusions of importance are as follows.

- A step-by-step approach has been developed and demonstrated, which provides a workable way to estimate present and near-term future risk based on the modeling assumptions.
- Aging in the AFW system at the analyzed plant has a negligible effect on plant CDF when aging of only the AFW system is assumed; however, with this assumption the interaction with aged components in other systems is not evaluated.
- Three aging models were considered: the exponential, Weibull, and linear failure rate models. With the data used, they produced very similar results at times during the data observation period and for extrapolations a few years into the future. However, the exponential model clearly behaved best for quantifying uncertainties, and the linear model clearly behaved worst, being in some ways unusable.
- The availability of statistical diagnostic tools encourages the analyst to check the validity of the modeling assumptions. In this demonstration, these routine checks identified clustering in one data set with

12 failures, necessitating a follow-up investigation. The other assumptions that were checked appeared acceptable in this demonstration.

We note the following difficulties in applying the approach. These observations are not surprising to people experienced in risk assessment.

- Aging cannot be detected without high-quality data covering a substantial time period. Ten years of data from the AFW system at two units provided minimal information, so that for many failure modes the degree of aging could not be estimated with precision.
- The data of this report are likely to represent a large plant-specific sample of failure events for the period of time examined. Other standby safety systems have been found to exhibit very few failures in a similar period of time (for example, Bier et al. 1990).
- Classification of failure data from old records is difficult. In this report, the problem was addressed by using broad and narrow definitions of failure. Judgment was also necessary in combining maintenance records that referred to the same event. In one case, inquiry at the power station resulted in a major reinterpretation of the maintenance records and a substantial change in the calculated CDF.
- Failures tend to cluster in time. In one case this cast strong doubt on the assumption of independent failures. In this demonstration, the difficulty was resolved by better interpretation of the raw maintenance reports. In other cases, it might be necessary to develop a model that does not assume independence.
- The maintenance and operational environment may have changed at times in the plant's history, resulting in permanent impact on trends. For example, it is possible

## Conclusions

that certain early failure mechanisms have been eliminated. Any such changes could not be determined from the maintenance records alone; they may, however, influence the estimated trend in the failure rate. The desire for data covering a substantial time period, mentioned above, conflicts with the fact that operational practices change over time.

To help interpret the maintenance records correctly, it is useful to have input from people directly familiar with the plant equipment, practices, and history. This partially removes some of the above difficulties, although others are inherent in any effort to detect and quantify aging.

We also make the following observations concerning the possible application of the methodology.

- Extrapolation of observed trends to the distant future would require more explicit incorporation of maintenance and replacement policies. They are treated implicitly here, as part of the environment for the observed past failure events. Therefore, the approach of this report should not be used for distant extrapolation.
- Periodic use of the approach at a plant is suggested as a means of supporting risk-based prioritization of surveillance, maintenance, and engineering analysis efforts.

For managers who must make decisions based on three models, two definitions of failure, and two significance levels, we, the authors of this report, offer the following suggestions. Use the exponential failure model. When aging of a component results in a significant increase in CDF, use a table similar to the following example.

**Table 8-1.** Example decision matrix.

	Broadly defined failures	Narrowly defined failures
No-aging assumption rejected at significance level of 0.40	Awareness. Inform operations and maintenance staffs of potential problem. Reanalyze if failures persist.	Strong interest. Inform operations and maintenance staffs of potential problem. Reanalyze after short period of time.
No-aging assumption rejected at significance level of 0.05	Strong interest. Investigate immediately to determine which maintenance records describe actual failures of concern.	Very strong interest. Investigate immediately and determine what mitigating action should be taken.



## 9. REFERENCES

- Alt, F. B., 1982, "Bonferroni Inequalities and Intervals," *Encyclopedia of Statistical Sciences*, Vol. 1, S. Kotz and N. L. Johnson (eds.), New York: John Wiley & Sons.
- Atwood, Corwin L., 1990, *User's Guide to PHAZE, a Computer Program for Parametric Hazard Function Estimation*, EGG-SSRE-9017.
- Atwood, Corwin L., 1992, "Parametric Estimation of Time-Dependent Failure Rates for Probabilistic Risk Assessment," *Reliability Engineering and System Safety*, 37, pp.181-194.
- Bartholomew, D. J., 1955, Discussion of article by D. R. Cox, *Journal of the Royal Statistical Society, Series B*, 17, pp. 162-163.
- Bier, V. M., D. C. Bley, Y.-M. Hou, D. H. Johnson, S. Kaplan, and J. E. Williamson, 1990, *Development and Demonstration of Methods for Nuclear Power Plant Aging Risk Analysis: Bayesian Data Analysis*, EGG-SSRE-8990, PLG-0743.
- Cox, D. R. and P. A. W. Lewis, 1966, *The Statistical Analysis of Series of Events*, Section 3.3, London: Chapman and Hall.
- Crow, Larry H., 1974, "Reliability Analysis for Complex, Repairable Systems," in *Reliability and Biometry: Statistical Analysis of Lifelength*, F. Proschan and R. J. Serfling (eds.), Philadelphia: SIAM, pp. 370-410.
- Crow, Larry H., 1982, "Confidence Interval Procedures for the Weibull Process with Applications to Reliability Growth," *Technometrics*, 24, pp. 67-72.
- Donelson, III, John, 1975, *Duane's Reliability Growth Model as a Nonhomogeneous Poisson Process*, P-1162, Arlington, VA: Institute for Defense Analysis, December.
- Engelhardt, Max, 1988, "Weibull Processes," *Encyclopedia of Statistical Sciences*, Vol. 9, S. Kotz and N. L. Johnson (eds.), New York: John Wiley & Sons.
- Ghahramani, K., 1989, "PRA Data Base Development: An Integrated Approach," *Proceedings of the International Topical Meeting on Probability, Reliability and Safety Assessment, Volume 2, April 2-7, Pittsburgh, Pennsylvania*, pp. 882-891.
- Hahn, G. J. and W. Q. Meeker, Jr., 1982, "Pitfalls and Practical Considerations in Product Life Analysis—Part I: Basic Concepts and Dangers of Extrapolation," *Journal of Quality Technology*, 14, pp. 144-152.
- Levy, I. S., J. Wreatherall, G. DeMoss, A. Wolford, E. P. Collins, and D. B. Jarrell, 1988, *Prioritization of TIRGALEX-Recommended Components for Further Aging Research*, NUREG/CR-5248, PNL-6701.
- Phillips, J. H., W. S. Roesener, H. L. Magleby, and V. Geidl, 1990, "Aging Risk of Passive Components, Status of the Project," *18th NRC Water Reactor Information Meeting, Rockville, MD, October 22-24*.
- Russell, Kenneth D. and Martin B. Sattison, 1989, *Integrated Reliability and Risk Analysis System (IRRAS), Version 2.0 User's Guide*, NUREG/CR-5111.
- Salvia, Anthony A., 1980, "Maximum Likelihood Estimation of Linear Failure Rate," *IEEE Transactions on Reliability*, R-29, pp. 49-50.

## References

Snee, Ronald D. and Charles G. Pfeifer, 1983, "Graphical Representation of Data," *Encyclopedia of Statistical Sciences*, Vol. 3, S. Kotz and N. L. Johnson (eds.), New York: John Wiley & Sons.

USNRC, 1987, *Nuclear Plant Aging Research (NPAR) Program Plan*, NUREG-1144, Revision 1.

USNRC, 1989, *Severe Accident Risk Assessment for Five U.S. Nuclear Power Plants*, NUREG-1150, Draft 2.

Vaurio, J. K., 1990, "On the Meaning of Probability and Frequency," *Reliability Engineering and System Safety*, 28, pp. 121-130.

Vesely, William E., 1987, *Risk Evaluations of Aging Phenomena: The Linear Aging Reliability Model and Its Extensions*, NUREG/CR-4769, EGG-2476.

Vesely, W. E., R. E. Kurth, and S. M. Scalzo, 1990, *Evaluation of Core Melt Frequency Effects Due to Component Aging and Maintenance*, NUREG/CR-5510.

**Appendix A**  
**Estimating Hazard Functions  
for Repairable Components**

The pages printed here as Appendix A have been issued as a separate EG&G Idaho report. They are reproduced here with page numbers changed to make them more accessible to readers of this NUREG.

# ESTIMATING HAZARD FUNCTIONS FOR REPAIRABLE COMPONENTS

Corwin L. Atwood

Published May 1990

Idaho National Engineering Laboratory  
EG&G Idaho  
Idaho Falls, ID 83415-3421

Prepared for the  
U.S. Nuclear Regulatory Commission  
Washington, D.C. 20555  
Under DOE Contract No. DE-AC07-76IDO1570

## ABSTRACT

This is a tutorial report, applying known formulas and tools in a way suitable for risk assessment. A parametric form is assumed for the hazard function of a set of identical components. The parameters are estimated, based on sequences of failure times when the components are restored to service (made as good as old) immediately after each failure. In certain circumstances, the failure counts are ancillary for the parameter that determines the shape of the hazard function; this suggests natural tools for diagnostic checks involving the individual parameters. General formulas are given for maximum likelihood estimators and approximate confidence regions for the parameters, yielding a confidence band for the hazard function. The results are applied to models where the hazard function is of linear, exponential, or Weibull form, and an example analysis of real data is presented.

**KEY WORDS:** Time-dependent failure rate, Non-homogeneous Poisson process, Poisson intensity, Exponential distribution, Exponential failure rate, Linear failure rate, Weibull distribution.

FIN No. A6389—Aging Components and Systems IV:  
Risk Evaluation and Aging Phenomena

## SUMMARY

This tutorial report presents a parametric framework for performing statistical inference on a hazard function, based on repairable data such as might be obtained from field experience rather than laboratory tests. This framework encompasses many possible forms for the hazard function, three of which are considered in some detail. The theory is neatest and the asymptotic approximations most successful when the hazard function has the form of a density in the exponential family. The results presented include formulas for maximum likelihood estimates (MLEs), tests and confidence regions, and asymptotic distributions. The confidence regions for the parameters are then translated into a confidence band for the hazard function. For the three examples considered in detail, a table gives all the building blocks needed to program the formulas on a computer; this table includes asymptotic approximations when they are necessary to maintain numerical accuracy. Diagnostic checks on the model assumptions are sketched.

The report gives an example analysis of real data. In this example, the methods are unable to discriminate among an exponential hazard function, a linear hazard function, and a Weibull hazard function. The MLE for the two parameters appears to have approximately a bivariate normal distribution under the exponential or Weibull hazard model, but not under the linear hazard model. If the analysis using approximate normality is carried out in any case, the results appear similar for all three models. If some model is preferred for theoretical or other reasons, the framework of this report indicates a way to use it.

## ACKNOWLEDGMENTS

I am grateful to my colleagues Andrew J. Wolford and W. Scott Roesener for the stimulus and insights provided during the course of this work. I also thank Max Engelhardt for pointing out early related papers.



## CONTENTS

ABSTRACT .....	A-4
SUMMARY .....	A-5
ACKNOWLEDGMENTS .....	A-6
1. INTRODUCTION .....	A-9
2. MODEL FORMULATION .....	A-10
2.1 Basic Assumptions and Definitions .....	A-10
2.2 One Notation for Two Types of Data .....	A-11
Types of Data .....	A-11
Unified Notation.....	A-12
2.3 Examples .....	A-13
Exponential Hazard Function .....	A-13
Linear Hazard Function .....	A-17
Weibull Hazard Function .....	A-18
3. LIKELIHOOD .....	A-18
3.1 Summary of Likelihood Formulas .....	A-18
3.2 Ancillarity .....	A-20
3.3 Examples .....	A-20
4. MAXIMUM LIKELIHOOD ESTIMATION .....	A-21
4.1 Maximum Likelihood Estimation Based on the Conditional Likelihood .....	A-21
4.2 Maximum Likelihood Estimation Based on the Full Likelihood .....	A-21
4.3 Examples .....	A-22
Exponential Hazard Function .....	A-22
Linear Hazard Function .....	A-23
Weibull Hazard Function .....	A-24
5. CONFIDENCE REGIONS AND HYPOTHESIS TESTS .....	A-25
5.1 Inference Based on the Conditional Likelihood .....	A-25
Inference for $\beta$ .....	A-25
Inference for $\lambda_0$ .....	A-27
5.2 Inference Based on the Full Likelihood .....	A-28
5.3 Examples .....	A-29
Exponential Hazard Function .....	A-29
Linear Hazard Function .....	A-30
Weibull Hazard Function .....	A-30

6.	DIAGNOSTIC CHECKS .....	A-31
6.1	Common $\beta$ .....	A-31
6.2	Common $\lambda_0$ .....	A-31
6.3	Form of $h(t)$ .....	A-32
6.4	Adequacy of Asymptotic Normal Approximation .....	A-33
7.	EXAMPLE DATA ANALYSIS .....	A-34
8.	DERIVATIONS AND PROOFS .....	A-40
8.1	Derivation for Time-Censored Data .....	A-42
	The Likelihood .....	A-42
	Ancillarity .....	A-42
8.2	Derivation for Failure-Censored Data .....	A-43
9.	REFERENCES .....	A-45

#### TABLES

1.	Formulas for examples considered .....	A-14
2.	Summary of example data .....	A-35

#### FIGURES

1.	Component Comparisons for $\beta$ , Exponential Hazard Model .....	A-35
2.	Q-Q Plot for Exponential Hazard Model .....	A-37
3.	Confidence Regions for $(\beta, \lambda_0)$ , Based on Exponential Hazard Model .....	A-38
4.	Confidence Regions for $(\beta, \lambda_0)$ , Based on Linear Hazard Model, Centered Data .....	A-38
5.	Confidence Regions for $(\beta, \lambda_0)$ , Based on Weibull Hazard Model .....	A-39
6.	Confidence Regions for $(\beta, \lambda_0)$ , Based on Linear Hazard Model, Uncentered Data .....	A-39
7.	MLE and 90% Confidence Band for $\lambda(t)$ , Based on Three Models .....	A-41

# ESTIMATING HAZARD FUNCTIONS FOR REPAIRABLE COMPONENTS

## 1. INTRODUCTION

This report is concerned with the failure behavior of components. It is a tutorial report, applying previously known results in a way suitable for risk assessment. The model is defined in terms of the random variable  $T$ , the (first) failure time of a component. In many published articles, it is assumed that many components are tested until their first failure. The resulting failure times are used as data, and the properties of the distribution of  $T$  are then inferred. By contrast, this report deals with field data, not test data: it is assumed that each failed component is immediately restored to operability (made as good as old) and again placed in service. The data then consist of a sequence of failure times for each component.

A question of interest is whether the hazard function (or failure rate) is increasing, that is, whether the failures tend to occur more frequently as time goes on. This and related questions are investigated by postulating a parametric form for the distribution of  $T$ , and then performing the usual statistical inference about the parameters of the model, with special emphasis on the parameter(s) that determine whether the hazard function is increasing. The final goals of the inference are a point estimate and a confidence interval for the hazard function at any time  $t$ .

The general methods are applied in detail to three assumed parametric forms for the hazard function. A table gives all the formulas needed to implement the methods on a computer for these three models.

The outline of the report is as follows. Section 2 presents the assumptions and notation, and introduces three examples. Sections 3, 4, and 5 develop the likelihood formulas and equations for maximum likelihood estimators and tests/confidence intervals. Each of these three sections also discusses the application of the general results to the three examples. People who can appreciate theory without considering examples may skip the application portions. Section 6 outlines diagnostic checks,

and Section 7 presents an analysis of data from motor-operated valves. Proofs are in Section 8.

## 2. MODEL FORMULATION

### 2.1 Basic Assumptions and Definitions

Assume that the failures of a component follow a time-dependent (or non-homogeneous) Poisson process. See, for example, Karr (1986) for a simple description, or Cox and Isham (1980) for a fuller introductory treatment. Alternatively, one can parallel the development from fundamental assumptions as given by Meyer (1970, Section 8.3) for the homogeneous case. The most important properties are the following: there is a nonnegative function  $\lambda(t)$  defined for  $t \geq 0$ , with the probability of a failure in a short period  $(t, t + \Delta t)$  asymptotically approaching  $\lambda(t)\Delta t$  as  $\Delta t \rightarrow 0$ ; the failure counts in non-overlapping time intervals are independent; and the number of failures occurring between 0 and  $t$  is a Poisson random variable with parameter  $\Lambda(t)$ , where

$$\Lambda(t) = \int_0^t \lambda(u) du .$$

Implicit in the independence property is the assumption that the component is restored to service immediately after any failure, with negligible repair time. In operational data, it is not uncommon to find that a component has failed several times in quick succession for the same reason. Presumably, the first repairs did not treat the true cause of the failure. This situation violates the independence property—the fact that a failure has occurred recently increases the chance that another failure will occur soon, because the problem may not have been really fixed. It may be difficult to force such data into the Poisson-process model: counting the failures as distinct ignores their apparent dependence, while counting them as a single failure may make the time to true repair far from negligible.

The function  $\lambda$  is called the *hazard function*, the *failure rate*, or the *intensity function* of the Poisson process, and  $\Lambda$  is the *cumulative hazard function*. Assume now that  $\lambda$  is continuous in  $t$ . It is related to the cumulative distribution function (c.d.f.)  $F$  of the time to first failure, and to the corresponding density function  $f$  by

$$\lambda(t) = f(t)/[1 - F(t)]$$

and

$$1 - F(t) = \exp[-\Lambda(t)] .$$

Any one of the three functions  $F$ ,  $f$ , and  $\lambda$  uniquely determines the others. Note that because  $F(t) \rightarrow 1$  as  $t \rightarrow \infty$ , it follows that

$$\lim_{t \rightarrow \infty} \Lambda(t) = \infty . \quad (1)$$

If  $\lambda(t)$  is constant, as has been assumed for simplicity in many studies, the time to first failure has an exponential distribution. Often the concern is whether  $\lambda(t)$  is increasing in  $t$ . It is therefore convenient to write  $\lambda$  in the form

$$\lambda(t) = \lambda_0 h(t; \beta). \quad (2)$$

Here,  $\lambda_0 > 0$  is a constant multiplier and  $h(t; \beta)$  determines the shape of  $\lambda(t)$ .

Because data generally come from more than one component, the following additional assumptions are made. The failures of one component are assumed to be independent of those of another component. All the components are assumed to have the same function  $h$  with the same value of  $\beta$ ; that is, a proportional hazards model is assumed. Depending on the context, it may or may not be assumed that the different components have the same value of  $\lambda_0$ . Some simple regularity conditions on  $h$ , needed for asymptotic results, are discussed at the beginning of the section on confidence intervals and tests.

Sometimes there are gaps in the failure data. For example, the plant may have been shut down for an extended period, during which no component failures were possible, or the failure data may not have been collected for some period. This can be accommodated in the above framework by treating each component as two components, one observed before the gap and one after the gap, having the same installation date and, at the analyst's discretion, the same or possibly different values of  $\lambda_0$ .

## 2.2 One Notation for Two Types of Data

### Types of Data

Failure data for a component can arise in a number of ways. Two simple ones to analyze are:

- A random number of failures in a fixed observation period (*time-censored data*)
- A fixed number of failures in a random observation period (*failure-censored data*).

The terms "time-censored" and "failure-censored" follow the analogous usage for tests that are terminated before all the items have failed (e.g. Nelson, 1982, Sec. 7.1). Time-censored data arise if there is a

fixed time period when the component is watched or plant records are examined. During that time, the component is restored to service after each failure. Failure-censored data might arise if the component is repaired until a predetermined number of failures has occurred, at which time the component is removed from service and replaced by a new component. Both of these types of data result in tractable formulas for statistical inference.

In reality, the decision to repair or replace a component is based on a number of considerations, such as the availability of replacement components, the severity of the particular failure mode (including the difficulty and cost of repair), and any recent history of failures. These considerations are difficult to express in a simple mathematical model. Therefore, only the two types listed are analyzed here. In practice, one might simplify reality by treating failures that resulted in component replacement as if they were failure-censored.

#### Unified Notation

Let  $s_0$  and  $s_1$  denote the beginning and end of the component's observation period;  $s_0$  does not necessarily coincide with the component's installation. Let  $n$  be the number of observed failures not counting any failure that results in replacement of the component. Let  $m$  be the total number of observed failures, including any failure that results in replacement. Let  $t_1, \dots, t_m$  denote the ordered failure times. The two special cases then are

- Time-censored data: The observation period is from  $s_0$  to a fixed time  $s_1$ . The random number of failures is  $n$ , and therefore  $m$  is random and equal to  $n$ .
- Failure-censored data: The number of failures is fixed at  $m$ , and  $n$  is therefore fixed at  $m - 1$ . The observation period starts at  $s_0$  and ends at a random time  $s_1$ , with  $s_1 = t_m$ .

In general there are  $C$  components, indexed by  $j$ , and the quantities defined above are all indexed by  $j$ :  $s_{0j}$ ,  $s_{1j}$ ,  $n_j$ ,  $m_j$ , and  $t_{ij}$ . In the formulas to be given, it is often convenient to define the midpoint  $\bar{s}_j = (s_{0j} + s_{1j})/2$ , and to define the range  $r_j = (s_{1j} - s_{0j})$ . This notation, sometimes with the subscript  $j$  suppressed, will be used without further comment.

Normally, time 0 is defined to be the installation time of the component. It may, however, be useful to center the data by measuring all times from some value in the middle of the observed time period(s). This can lead to negative failure times, allowed in the above formulation.

## 2.3 Examples

The methods of this report are applicable to a rather arbitrary hazard function, such as the ones discussed by Cox and Oakes (1984, Chapter 2). Three such examples of hazard functions are considered in this report. In each example,  $\beta$  is one-dimensional, the hazard function is increasing if  $\beta > 0$ , is constant if  $\beta = 0$ , and is decreasing if  $\beta < 0$ . The units of  $\lambda_0$  are 1/time. The units of  $\beta$  depend on the example, but make  $h(t;\beta)$  dimensionless in every case.

In some of the work presented below, the hazard function is treated as proportional to a density function. Therefore, models can be expected to be most tractable when the hazard function is of a standard form, such as a member of the exponential family. This is illustrated by the three examples of this report, with the linear hazard model consistently producing problems that the exponential and Weibull hazard models do not have. The differences result from the fact that  $\log\lambda(t)$  is linear in  $\beta$  for the exponential and Weibull models, but not for the linear hazard model.

Various formulas and expressions are developed throughout this report. The forms that these expressions take in the example models are all collected in Table 1, given at the end of the report. To program the formulas for a computer, sometimes asymptotic approximations must be used to maintain numerical accuracy. These approximations are also given in Table 1. All the formulas of Table 1 were either derived or confirmed by using the symbolic computer program Mathematica (Wolfram, 1988).

### Exponential Hazard Function

The hazard function is defined by

$$\lambda(t) = \lambda_0 \exp(\beta t),$$

with  $\beta$  measured in units of 1/time. This example is considered in detail by Cox and Lewis (1966, Section 3.3). If  $\beta$  is negative, then  $\lambda$  does not integrate to  $\infty$  and Equation (1) is not satisfied; therefore,  $\lambda$  is not a hazard function. This quirk is interesting, but is not important in practice. It is certainly possible for  $\lambda(t)$  to have exponential form with negative  $\beta$  for  $t$  in the time period when data are observed, and to have some other form for other  $t$ , so that  $\lambda$  integrates to  $\infty$ . In this case,  $\lambda$  is a hazard function, and it is decreasing exponentially in the observed time period.

Table 1. Formulas for examples considered

Expression	Model		
	Exponential	Linear <sup>a</sup>	Weibull <sup>b</sup>
Constraints	None for $t$ in finite interval	$-1/\max(s_{1j}) < \beta < -1/\min(s_{0j})$ $s_{1j} > 0$ $s_{0j} < 0$	$\beta > -1$
$h(t)$ [Eq. (2) <sup>c</sup> ]	$\exp(\beta t)$	$1 + \beta t$	$(t/t_0)^\beta$
Cond. suff. stat for $\beta$	$\Sigma \Sigma T_{ij}$	$(\dots, T_{ij}, \dots)$	$\Sigma \Sigma \log T_{ij}$
$[\log h(t)]'$	$t$	$t/(1+\beta t)$	$\log(t/t_0)$
$[\log h(t)]''$	0	$-[t/(1+\beta t)]^2$	0
$\int [\log h(t)]'' h(t)^d$	0	$-\{\log[(1+\beta s_1)/(1+\beta s_0)]$ $-\beta r + \beta^2 r \bar{s}\} / \beta^3$	0
$v$ [Eq. (3) <sup>c</sup> ]	$\exp(\beta s_0)[\exp(\beta r) - 1] / \beta$	$r(1+\beta \bar{s})$	$t_0 C_0^{b,e} / (\beta+1)$
Asymptotic <sup>f</sup>			
$x, A$	$\beta r, \exp(\beta s_0)r$		$\beta+1, t_0$
$a_0$	1		$D_1^{b,e}$
$a_1$	1/2		$D_2$
$a_2$	1/6		$D_3$
$v'$	$\exp(\beta s_0)[\beta(s_1 e^{\beta r} - s_0)$ $-(e^{\beta r} - 1)] / \beta^2$	$r \bar{s}$	$t_0 [C_1^{b,e} - C_0 / (\beta+1)]$ $/ (\beta+1)$
Asymptotic <sup>f</sup>			
$x, A$	$\beta r, \exp(\beta s_0)r$		$\beta+1, t_0$
$a_0$	$\bar{s}$		$D_2^{b,e}$
$a_1$	$s_0/2 + r/3$		$2D_3$
$a_2$	$s_0/6 + r/8$		$3D_4$
$v''$	$\exp(\beta s_0) [e^{\beta r}(1 - \beta s_1)^2$ $-(1 - \beta s_0)^2$ $+ e^{\beta r} - 1] / \beta^3$	0	$t_0 [C_2 - 2C_1 / (\beta+1)$ $+ 2C_0 / (\beta+1)^2] / (\beta+1)^{b,e}$



Table 1. (continued)

Asymptotic <sup>f</sup>			
$x, A$	$\beta r, \exp(\beta s_0)r$		$\beta+1, t_0$
$a_0$	$s_0^2 + s_0 r + r^2/3$		$2D3^{b,e}$
$a_1$	$s_0^2/2 + 2s_0 r/3 + r^2/4$		$6D4$
$a_2$	$s_0^2/6 + s_0 r/4 + r^2/10$		$12D5$
$[\log v]'$	$s_0 - 1/\beta$	$\bar{s}/(1+\beta\bar{s})$	$C1/C0^{b,e} - 1/(\beta+1)$
Asymptotic <sup>f</sup>	$+r/[1-\exp(-\beta r)]$		
$x, A$	$\beta r, 1$		$(\beta+1), 1/2$
$a_0$	$\bar{s}$		$\log s_0 + \log s_1$
$a_1$	$r/12$		$D1^2/6^{b,e}$
$a_2$	$0$		$0$
$a_3$	$-r/720$		$-D1^4/360$
$[\log v]''$	$r^2 u/(1+a^2 u),$ $a = \beta r$ $u = (e^a + e^{-a} - 2 - a^2)/a^4$ $\approx (1/12)[1 + a^2/30 + a^4/1680]$	$-\bar{s}/(1+\beta\bar{s})^2$	$C2^{b,e}/C0 - (C1/C0)^2 + 1/(\beta+1)^2$
$-\int[\log h(t)]''h(t)/v$	See individual terms	$\{-\beta r + (1+\beta\bar{s}) \times$	See individual terms
$+ [\log v]''$		$\log[(1+\beta s_1)/(1+\beta s_0)]\}$	
Asymptotic <sup>f</sup>		$/ \{r\beta^3(1+\beta\bar{s})^2\}$	
$x, A$	See $[\log v]''$	$\beta, [r/(1+\beta\bar{s})]^2$	$(\beta+1), D1^2/12^{b,e}$
$a_0$		$1/12$	$1$
$a_1$		$-\bar{s}/6$	$0$
$a_2$		$(20\bar{s}^2 + r^2)/80$	$-D1^2/20$
$a_3$		$-(\bar{s}^3/3 + r^2\bar{s}/20)^g$	
$a_4$		$(560\bar{s}^4 + 168r^2\bar{s}^2$	$+ 3r^4)/1344$

Table 1. (continued)

$$L'(0)/[I(0)]^{1/2} \frac{\Sigma\Sigma(t_{ij}-\bar{s}_j)}{[\Sigma n_j r_j^2/12]^{1/2}} \quad \Sigma\Sigma(t_{ij}-\bar{s}_j) \frac{\Sigma\Sigma(t_{ij}-\bar{s}_j)}{[\Sigma n_j r_j^2/12]^{1/2}} \quad \text{See text}$$

a. If the data are centered at  $t_{mid} = \Sigma r_j \bar{s}_j / \Sigma r_j$ , then  $t_{ij}$ ,  $s_{0j}$ , and  $s_{1j}$  must be replaced by  $t_{ij} - t_{mid}$ ,  $s_{0j} - t_{mid}$ , and  $s_{1j} - t_{mid}$ , respectively, and  $\Sigma v_j$  and its derivatives are replaced by 0.

b. For the Weibull failure rate model, any terms involving  $s_0$  should be omitted if  $s_0 = 0$ . In this case, the asymptotic expressions are not needed.

c. Equation numbers refer to defining equations in text.

d. The integral is for  $t$  from  $s_0$  to  $s_1$ .

e. The notation  $Ck$  is defined as  $(s_1/t_0)^{\beta+1} [\log(s_1/t_0)]^k - (s_0/t_0)^{\beta+1} [\log(s_0/t_0)]^k$ , for  $k = 0, 1, 2$ . The notation  $Dk$  is defined as  $\{[\log(s_1/t_0)]^k - [\log(s_0/t_0)]^k\}/k!$ , for  $k = 1, 2, 3, 4, 5$ .

f. The asymptotic approximation of the expression in the line immediately above is of the form  $A \Sigma a_k x^k$ . The next lines give the variable  $x$  and the values of  $A$ ,  $a_0$ ,  $a_1$ , .... The expression may be computed as  $A(a_0 + a_1 x)$  if  $a_2 x^2$  is numerically insignificant compared to  $a_0$ . For example, under the exponential failure rate model, the asymptotic approximation for  $v$  is  $v \approx \exp(\beta s_0) r [1 + (1/2)\beta r + (1/6)(\beta r)^2 + \dots]$ .

Therefore,  $v$  may be computed as  $\exp(\beta s_0) r (1 + \beta r/2)$  if  $1 + (\beta r)^2/6 = 1$

to the limits of the machine accuracy.

g. On a machine where a number has approximately 16 significant digits (IBM PC double precision), for 5-digit accuracy in all cases, including cases when  $\bar{s}$  is virtually zero, the expansion for the linear hazard model should be evaluated out to the  $\beta^4$  term. If this term is negligible compared to  $a_0$ , the series through the  $\beta^3$  term should be used to evaluate the expression.

The constant  $\lambda_0$  is interpreted as the value of  $\lambda(t)$  at time  $t = 0$ . This time 0 is customarily taken to be the component's installation time, but any other time is allowed in principle. Measuring  $t$  from a time other than the installation may make  $t$  negative, which is allowed. If each component has a different  $\lambda_{0j}$ , the hazard function of each component changes by the same relative amount in any specified time, but the hazard functions of the components are not equal. For example, the hazard function doubles every  $(\log 2)/\beta$  time units, regardless of  $\lambda_{0j}$  and regardless of what time is assigned the value 0.

### Linear Hazard Function

The hazard function is defined by

$$\lambda(t) = \lambda_0 + at = \lambda_0(1 + \beta t),$$

with  $\beta$  measured in units of 1/time. This distribution is mentioned by Johnson and Kotz (1970b). Salvia (1980) uses the model with test data, in which many components are tested until their first failures. Vesely (1987) uses the model with field data for which failures from aging (corresponding to the increasing portion of the hazard function) can be distinguished from failures from other causes (corresponding to the constant portion of the hazard function). The cases considered by Salvia and Vesely both turn out to be much simpler analytically than the cases considered in this report.

As with the exponential hazard model, it is possible that  $\lambda$  has the specified form for the time period for which data are observed, and some other form for other  $t$ . Therefore, it is possible for  $\beta$  to be negative. However,  $\beta$  must not be such that  $\lambda(t)$  is negative in the observed time period. In fact, not even  $\lambda(t) = 0$  is allowed, because  $\log \lambda(t)$  is often used in the methods below. The details are complicated by the fact that it is sometimes convenient to center the data, leading to observed times expressed as negative values. Let  $s_{0j}$  and  $s_{1j}$  be the beginning and ending observation times for component  $j$ , following the unified notation defined above. To keep  $\lambda(t)$  positive for all observed times,  $\beta$  must satisfy  $\beta > -1/s_{1j}$  for all positive  $s_{1j}$ , and  $\beta < -1/s_{0j}$  for all negative  $s_{0j}$ .

The constant  $\lambda_0$  is the value of the hazard function at time  $t = 0$ . This time is the component's installation time, or the central time, depending on how time is measured. Note that the *relative* change in the hazard function approaches 0 as  $t \rightarrow \infty$ . For example when  $\beta > 0$ , the hazard function doubles from the value at  $t = 0$  in  $1/\beta$  time units, doubles again in the next  $2/\beta$  time units,

and so forth.

### Weibull Hazard Function

The hazard function is defined by

$$\lambda(t) = \lambda_0(t/t_0)^\beta,$$

where  $t_0 > 0$  is a normalizing time. It is common (Johnson and Kotz, 1970a, Cox and Oakes, 1984) to write the exponent as  $c - 1$ . The  $\beta$  notation is consistent with the other two examples because  $\beta = 0$  corresponds to a constant failure rate. Both  $t$  and  $t_0$  have units of time, and  $\beta$  is dimensionless. The constant  $\lambda_0$  is measured in units of 1/time, and is the value of the failure rate at time  $t = t_0$ . Changing  $t_0$  does not change the value of  $\beta$ , but does change the value of  $\lambda_0$ . For  $\lambda(t)$  to be integrable at 0,  $\beta$  must satisfy the constraint  $\beta > -1$ . Negative times are not allowed. If  $\beta > 0$ ,  $\lambda(0)$  equals 0; if  $\beta \leq 0$ ,  $\lambda(0)$  is undefined.

The hazard function doubles between times  $t_1$  and  $t_2$  if  $\log t_2 - \log t_1 = (\log 2)/\beta$ . Because  $\lambda(0)$  is either zero or undefined, the hazard function cannot double from the initial value.

## 3. LIKELIHOOD

### 3.1 Summary of Likelihood Formulas

In this section, the expressions for the likelihood are presented. All derivations and proofs are given in Section 8.

Let  $C$  denote the number of components. Define

$$H(t; \beta) = \int_0^t h(u; \beta) du$$

and

$$v_j(\beta) = H(s_{1j}; \beta) - H(s_{0j}; \beta) . \quad (3)$$

Depending on whether the data are time- or failure-censored,  $v_j$  is fixed or is the realization of a random variable. The parameter  $\beta$  will sometimes not be shown.

The logarithm of the likelihood based on all the data is shown in Section 8 to be

$$L_{full}(\beta, \lambda_{01}, \dots, \lambda_{0c}) = \sum_{j=1}^c \left[ \sum_{i=1}^{m_j} \log h(t_{ij}; \beta) + m_j \log \lambda_{0j} - \lambda_{0j} v_j(\beta) \right]. \quad (4)$$

This follows the unified notation established earlier, with the interpretation of  $m_j$  and  $s_{1j}$  depending on the way the data for the  $j$ th component were generated. The values of  $\lambda_{0j}$  may be distinct, or assumed to all be equal to a common  $\lambda_0$ . In the latter case,  $L_{full}$  depends only on  $\beta$  and  $\lambda_0$ , and can be written as

$$L_{full}(\beta, \lambda_0) = \sum_{j=1}^c \left[ \sum_{i=1}^{m_j} \log h(t_{ij}; \beta) + m_j \log \lambda_0 - \lambda_0 v_j(\beta) \right]. \quad (4')$$

Now consider the conditional distribution of the ordered failure times, conditional on the values of  $n_j$  or  $t_{m_j}$ , whichever is random. The conditional log-likelihood is shown in Section 8 to be

$$L_{cond}(\beta) = \sum_{j=1}^c \left[ \sum_{i=1}^{n_j} \log h(t_{ij}; \beta) - n_j \log v_j(\beta) + \log(n_j!) \right] \quad (5)$$

$$= \sum_{j=1}^c \log \left\{ (n_j!) \prod_{i=1}^{n_j} [h(t_{ij}; \beta) / v_j(\beta)] \right\}. \quad (5')$$

From now on, the subscripts *full* and *cond* will be omitted, with the meaning being clear from the number of parameters given as arguments of  $L$ . It is crucial to note that the conditional log-likelihood (5) depends on  $\beta$ , but not on  $\lambda_0$  or the  $\lambda_{0j}$ 's.

For component  $j$ , consider the term inside curly brackets in Expression (5'), and suppress the index  $j$ . The expression is the conditional joint density of the ordered failure times  $(T_1, \dots, T_n)$ . Therefore, conditional on  $N = n$  or  $T_m = t_m$ , the  $n$  unordered failure times  $T_i$  are independent and identically distributed (i.i.d.), each with density  $h(t)/v$  on the interval  $[s_0, s_1]$ , and density 0 outside this interval. Therefore, inference for  $\beta$  can be performed in standard ways, based on observations that are conditionally independent, and conditionally identically distributed for each component. This can be done whether or not the components have a common value of  $\lambda_0$ .

Two other facts are needed to carry out inference for all the parameters. For time-censored data,  $N_j$  is Poisson( $\lambda_{0j} v_j$ ). For failure-censored data, it is shown in Section 8 that  $2\lambda_{0j} V_j$  has a  $\chi^2(2m_j)$  distribution. The values of  $\lambda_{0j}$  may or may not be assumed to equal some common value.

### 3.2 Ancillarity

Suppose that there is a multidimensional parameter  $(\beta, \theta)$ , and a sufficient statistic  $(X, Y)$ .  $Y$  is said to be *ancillary* for  $\beta$  if the marginal distribution of  $Y$  does not depend on  $\beta$ .  $X$  is called *conditionally sufficient* for  $\beta$  if the conditional distribution of  $X$  given  $y$  does not depend on  $\theta$ . When these conditions hold, inference for  $\beta$  should be based on the conditional likelihood of  $X$  given  $y$ . When maximum likelihood estimation is used, the same value for  $\hat{\beta}$  is found whether the full likelihood or the conditional likelihood is used, but the appropriate variance of  $\hat{\beta}$  is the conditional variance. See Kalbfleisch (1982) or Cox and Hinkley (1974, Sections 2.2viii and 4.8ii) for more information.

Return now to the setting of component failures, and consider time-censored data from  $C$  components, when either (1) the components are not assumed to have a common value of  $\lambda_0$ , or (2) the components have a common  $\lambda_0$  and all the  $v_j$ 's have a common value. In the examples of this report, case (2) can occur only if all the components are observed over the same period  $s_0$  to  $s_1$ . For case (1), it is shown in Section 8 that  $(N_1, \dots, N_C)$  is ancillary for  $\beta$ , and that the failure times  $T_{i;j}$  form a conditionally sufficient statistic for  $\beta$ . (A lower dimensional conditionally sufficient statistic for  $\beta$  can be determined in some examples by examining the form of  $\Sigma \Sigma \log h(T_{i;j})$ .) For case (2), the components may be pooled into a single super-component, and  $N = \Sigma N_j$  is ancillary for  $\beta$ . In these cases, therefore, basing inference for  $\beta$  on Equation (5) is not only possible but best. In all other cases, basing inference for  $\beta$  on Equation (5) involves some loss of information.

### 3.3 Examples

The building blocks for the above formulas are all given in Table 1, at the end of this report. A few points are worth noting here: The exponential hazard model is worked out in some detail by Cox and Lewis (1966, Section 3.3). With this model,  $\Sigma \Sigma \log h(T_{i;j}; \beta)$  equals  $\beta \Sigma \Sigma T_{i;j}$ , and it follows that that  $\Sigma \Sigma T_{i;j}$  is conditionally sufficient for  $\beta$ . For the linear hazard function,  $\Sigma \Sigma \log h(T_{i;j}; \beta)$  equals  $\Sigma \Sigma \log(1 + \beta T_{i;j})$ , and there is no one-dimensional statistic that is conditionally sufficient for  $\beta$ . This is one of several problems with the linear hazard model, which will be mentioned in this report as they are encountered. For the Weibull hazard function, we have  $\log h(T; \beta) = \beta \log(T/t_0)$ . Therefore,  $\Sigma \Sigma \log T_{i;j}$  is conditionally sufficient for  $\beta$ .

## 4. MAXIMUM LIKELIHOOD ESTIMATION

### 4.1 Maximum Likelihood Estimation Based on the Conditional Likelihood

If  $(N_1, \dots, N_c)$  is ancillary for  $\beta$ , then inference for  $\beta$  should be based on the conditional log-likelihood given by Equation (5). Even in other cases, one could use this conditional log-likelihood at the cost of some loss of information. The maximum conditional likelihood equation is formed by setting the derivative of Expression (5) with respect to  $\beta$  equal to 0, resulting in:

$$L'(\beta) = \sum_{j=1}^c \sum_{i=1}^{n_j} \{ [\log h(t_{ij}; \beta)]' - [\log v_j(\beta)]' \} = 0 . \quad (6)$$

Here, the prime denotes the derivative with respect to  $\beta$ . If  $\beta$  has dimension  $k$ , there are  $k$  such equations, each involving the partial derivative with respect to one component of  $\beta$ . The maximum likelihood estimate (MLE)  $\hat{\beta}$  typically is found by numerical iteration to solve Equation (6). If any algebraic cancellation can be performed on the terms inside the curly brackets in Equation (6), then the order of evaluation should be as suggested by the bracketing, for numerical accuracy. If no algebraic cancellation can be performed, the evaluation may take advantage of the fact that  $\sum_i [\log v_j]' = n_j [\log v_j]'$ .

Suppose that no common value of  $\lambda_0$  is assumed. The MLE of  $\lambda_{0j}$ , corresponding to the  $j$ th component, is  $\hat{\lambda}_{0j} = m_j / v_j(\hat{\beta})$ . This is shown directly from Equation (4) by maximizing  $L(\hat{\beta}, \lambda_{01}, \dots, \lambda_{0c})$  with respect to  $\lambda_{0j}$ . Suppose instead that a common value of  $\lambda_0$  is assumed for all  $C$  components. Then it is shown similarly that  $\hat{\lambda}_0 = \Sigma m_j / \Sigma v_j(\hat{\beta})$ .

### 4.2 Maximum Likelihood Estimation Based on the Full Likelihood

Inference proceeds first by estimating  $\lambda_0$ , if a single common value is assumed, or by estimating the various  $\lambda_{0j}$ . Substitute the MLE(s) into the expression for the full log-likelihood, differentiate the resulting expression with respect to  $\beta$ , and find the MLE  $\hat{\beta}$ .

When no common  $\lambda_0$  is assumed, the equation for  $\hat{\beta}$  is

$$(\partial/\partial\beta)L(\beta, \hat{\lambda}_{01}, \dots, \hat{\lambda}_{0c}) = \sum_{j=1}^c \sum_{i=1}^{m_j} \{ [\log h(t_{ij}; \beta)]' - [\log v_j(\beta)]' \} = 0 . \quad (7)$$

This is identical to Equation (6), except that  $m$  appears in place of  $n$ . Therefore, use of either the conditional or the full likelihood yields the same MLE  $\hat{\beta}$  from time-censored data; this agrees with the conclusion of the ancillarity argument given earlier. For failure-censored data, Equation (7) differs from Equation (6) by inclusion of the final failure times  $t_m$  and use of  $m = n + 1$ .

When a common  $\lambda_0$  is assumed, the maximum likelihood equation for  $\hat{\beta}$  is

$$\sum_{j=1}^c L_j'(\beta, \hat{\lambda}_0) = \sum_{j=1}^c \sum_{i=1}^{m_j} [\log h(t_{ij}; \beta)]' - (\Sigma m_j) [\Sigma v_j'(\beta)] / [\Sigma v_j(\beta)] = 0 . \quad (8)$$

This differs from Equation (6) in two ways:  $m_j$  is used instead of  $n_j$ , which makes a difference only with failure-censored data; and the portion involving  $v_j$  reverses the order of summation and multiplication and division.

### 4.3 Examples

All the expressions used in Equations (6) through (8) are presented in Table 1, for the three examples. A few points of interest are mentioned here. Typical features of all the models are discussed using the first example as an illustration.

#### Exponential Hazard Function

Consider first estimation based on the conditional likelihood. The maximum conditional likelihood equation for  $\beta$  is, from Equation (6) and the expressions given in Table 1,

$$\sum_{j=1}^c \sum_{i=1}^{n_j} (t_{ij} - s_{0j}) + \sum_{j=1}^c n_j / \beta - \sum_{j=1}^c n_j r_j / [1 - \exp(-\beta r_j)] = 0 . \quad (9)$$

This agrees with the special case  $C = 1$  and  $s_0 = 0$  worked out by Cox and Lewis (1966). It must be solved numerically for  $\hat{\beta}$ . When  $\beta$  is near 0, the last two terms in Equation (9) are very large, although the difference is bounded. Therefore an asymptotic approximation should be used. From expressions given in Table 1, a first order approximation is

$$\sum_{j=1}^c \sum_{i=1}^{n_j} \left\{ (t_{ij} - s_{0j}) - (r_j/2)(1 + \beta r_j/6) \right\} = 0 .$$



When  $\beta$  is small, this asymptotic approximation must be used to prevent complete loss of numerical significance; of course, when  $\beta = 0$  the limiting value must be used. Note that  $\hat{\beta}$  equals 0 when

$$\Sigma \Sigma t_{ij} = \Sigma n_j \bar{s}_j,$$

that is, when the sum of the (non-replacement) failure times equals the corresponding sum of the mid-points of the observation periods. This is intuitively consistent with the fact that when  $\beta$  equals 0, the conditional distribution of  $T_{ij}$  is uniform on  $(s_0, s_1)$ . The MLE for  $\lambda_0$  or for the  $\lambda_{0j}$ 's can be obtained in a direct way from the results given above.

Inference based on the full likelihood is similar, using Equation (7) or (8) and expressions given in Table 1.

### Linear Hazard Function

It is straightforward to substitute the expressions for  $h(t)$  and  $v_j$  into the general equations given above. For example, consider the conditional log-likelihood based on a single component. Its derivative is

$$L'(\beta) = \Sigma t_i / (1 + \beta t_i) - n \bar{s} / (1 + \beta \bar{s}) .$$

It follows that the MLE  $\hat{\beta}$ , based on the conditional log-likelihood, equals zero if  $\Sigma \Sigma t_{ij} = \Sigma n_j \bar{s}_j$ , just as with the exponential hazard model. The following two points, however, deserve special notice:

The MLE  $\hat{\beta}$  may be infinite. To see this, consider the expression for  $L'(\beta)$  just given. If  $t_i > \bar{s}$  for all  $i$ , then  $L'(\beta)$  is positive for all  $\beta$ . There is no finite solution to the maximum likelihood equation. Thus, in cases when the evidence for an increasing failure rate is strongest, the rate of increase may not be estimable by maximum likelihood.

With time-censored data and a common  $\lambda_0$  assumed, there is some advantage to centering the data. In this case  $m_j \equiv n_j$ , and the full log-likelihood is

$$L(\beta, \lambda_0) = \Sigma n_j \log \lambda_0 + \Sigma \Sigma \log(1 + \beta t_{ij}) - \lambda_0 \Sigma r_j - \lambda_0 \beta \Sigma r_j \bar{s}_j .$$

The last sum can be made to vanish by centering the data, that is, by measuring all times from

$$t_{mid} = \Sigma r_j \bar{s}_j / \Sigma r_j .$$

The log-likelihood then becomes

$$L(\beta, \lambda_0) = \Sigma n_j \log \lambda_0 + \Sigma \Sigma \log[1 + \beta(t_{ij} - t_{mid})] - \lambda_0 \Sigma r_j .$$

In this formulation,  $\lambda_0$  equals the value of  $\lambda(t)$  at  $t = t_{mid}$ . If any value is assumed for  $\beta$ ,  $\Sigma N_j$  is

Poisson( $\lambda_0 \Sigma r_j$ ), independent of  $\beta$ . Similarly, if any value is assumed for  $\lambda_0$ ,  $L(\beta, \lambda_0)$  is a function of  $\lambda_0$  plus a function of  $\beta$  and the  $t_{ij}$ 's; therefore, inference for  $\beta$  is independent of  $\lambda_0$ . This ability to perform independent inference for  $\beta$  and  $\lambda_0$  is a convenient property, which may be sufficient in the eyes of some analysts to justify centering the data.

Suppose that when the data are uncentered, there is no finite MLE  $\hat{\beta}$ . Centering the data is not a cure-all. When the data are centered,  $\beta$  is restricted to a finite range, as discussed in the introduction to the linear hazard model in Section 2. In this case, the MLE  $\hat{\beta}$  is at an end point of the possible range; it is finite, but cannot be treated as asymptotically normal.

### Weibull Hazard Function

In this case,  $[\log h(t_{ij})]' = \log(t_{ij}/t_0)$ . The remaining terms needed for Equations (6), (7), and (8) depend on whether  $s_{0j}$  is zero or nonzero, and are all given in Table 1.

There is a noteworthy simplification in Equations (6) and (7) when  $s_{0j} = 0$  for all  $j$ , that is, when every component is observed from its time of installation. In this case,  $[\log v]'$  equals  $\log(s_1/t_0) - 1/(\beta + 1)$ , and Equation (6) has the explicit solution

$$\hat{\beta} = -\Sigma n_j / \Sigma \Sigma \log(t_{ij}/s_{1j}) - 1 . \quad (10)$$

The solution of Equation (7) replaces  $n_j$  by  $m_j$ . These are the only cases considered in this report for which the MLE  $\hat{\beta}$  can be found without numerical iteration.

In this case, the value  $\hat{\beta}$  satisfying Equation (6) equals 0 not when  $\Sigma \Sigma t_{ij}$  equals  $\Sigma n_j \bar{s}_j$ , as in the other examples, but when

$$-\Sigma \Sigma \log(t_{ij}/s_{1j}) = \Sigma n_j .$$

This initially surprising fact has the following intuitive basis. For notational simplicity, consider a single component, suppress the index  $j$ , let  $t_0 = 1$ , and condition the observations on the value of  $n$  or  $s_1$ . To derive the conditional distribution of  $-\log(T_i/s_1)$ , begin with

$$P[-\log(T_i/s_1) > x] = P[T_i < s_1 \exp(-x)] .$$

Following the discussion below Equation (5),  $T_i$  has conditional density  $h(t)/v$ ; therefore, this probability equals

$$\{[s_1 \exp(-x)]^{\beta+1} / (\beta + 1)\} / \{s_1^{\beta+1} / (\beta + 1)\} = \exp[-x(\beta + 1)] .$$

Therefore, the conditional distribution of  $-\log(T_i/s_1)$  is exponential with mean  $\mu = 1/(\beta + 1)$ .

Equation (10) can be rewritten as

$$-\Sigma \log(t_{ij}/s_{1j}) / \Sigma n_j = 1/(\hat{\beta} + 1) = \hat{\mu} ,$$

that is, the MLE is based on equating the mean of  $-\log(T_{ij}/s_{1j})$  to the sample mean. In particular, the case  $\hat{\beta} = 0$  corresponds to  $\hat{\mu} = 1$ , that is,  $-\Sigma \log(t_{ij}/s_{1j}) / \Sigma n_j = 1$ .

When the values of  $s_{0j}$  are not all zero, the expressions are more complicated, but the maximum likelihood equation is still equivalent to setting the mean of  $\Sigma \log T_{ij}$  equal to its sample mean.

## 5. CONFIDENCE REGIONS AND HYPOTHESIS TESTS

The standard regularity conditions, such as given by Cox and Hinkley (1974, Section 9.1) are assumed. The assumptions involving the parameter space, identifiability of the distributions, and existence of derivatives are all satisfied in the examples considered in this report. There is also an assumption involving the behavior of the third derivative of the log-likelihood as  $n$  goes to infinity. For field data, such an assumption is typically difficult to affirm or deny. Practitioners must always treat asymptotic approximations with care.

### 5.1 Inference Based on the Conditional Likelihood

The procedure described here might be used when  $\beta$  is the primary parameter of interest, or when  $(N_1, \dots, N_c)$  is ancillary for  $\beta$ . The presentation here assumes that  $\beta$  is one-dimensional. The generalizations to multidimensional  $\beta$  are straightforward. We remark in passing that when  $\log h(t)$  is linear in one-dimensional  $\beta$ , as is the case for the exponential and Weibull models, then the one-sided tests given below are uniformly most powerful.

Inference for  $\beta$

The derivative with respect to  $\beta$  of the conditional log-likelihood,  $L'(\beta)$ , is given by Equation (6). The information is

$$I(\beta) = -E[L''(\beta)] = E\{ [L'(\beta)]^2 \}$$

$$\begin{aligned}
&= -E \left\{ \sum_{j=1}^c \sum_{i=1}^{n_j} [\log h(t_{ij}; \beta)]'' - \sum_{j=1}^c n_j [\log v_j(\beta)]'' \right\} \\
&= \Sigma_j n_j \left\{ -\int [\log h(t; \beta)]'' h(t; \beta) dt / v_j(\beta) + [\log v_j(\beta)]'' \right\} .
\end{aligned} \tag{11}$$

If  $\beta$  is  $k$ -dimensional,  $I(\beta)$  is the  $k \times k$  matrix defined by taking all the mixed partial derivatives of  $L$ . Let  $\beta$  be the true value. Under the assumed regularity conditions, the expectation of  $L'(\beta)$  is 0, and the variance (or covariance matrix for  $k$ -dimensional  $\beta$ ) of  $L'(\beta)$  is  $I(\beta)$ .

As a corollary to the Lindeberg-Feller Central Limit Theorem, Feller (1968, Section X.5) gives a sufficient condition for asymptotic normality of  $L'(\beta)$ . Rewrite Equation (6) as  $L'(\beta) = \Sigma \Sigma X_k$ . If there is a constant  $A$  such that  $|X_k| < A$  for all  $k$ , and if  $(11) \rightarrow \infty$ , then

$$L'(\beta_0) / [I(\beta_0)]^{1/2} \tag{12}$$

converges in distribution to normal(0,1). The assumptions must be verified for each example. Typically, the assumptions are satisfied if all the values of  $s_{0j}$  and  $s_{1j}$  are bounded by some constant, and if some fixed fraction of the  $r_j$ 's is bounded away from 0. For the exponential hazard model, it is enough for the  $r_j$ 's to be bounded by some constant and for a fixed fraction to be bounded away from 0. For the linear hazard model, it is necessary in addition for  $1 + \beta s_{0j}$  and  $1 + \beta s_{1j}$  to be uniformly bounded away from 0. Qualitatively, the approximation is best if the  $s_{0j}$ 's are approximately equal and if the  $s_{1j}$ 's are approximately equal. The approximation also is better if  $\beta$  and  $h$  are such that  $[\log h(T_{ij}; \beta)]'$  does not have a highly skewed distribution. If it is very important to know whether the normal approximation is adequate in some application, a simulation study should be performed.

An approximate confidence interval for  $\beta$  is the set of all  $\beta_0$  such that the statistic (12) lies in the interval  $(-c, c)$ , where  $c$  is the appropriate number from a normal table; for example,  $c = 1.96$  yields an approximate 95% confidence interval. Actually, this defines a confidence *region* for  $\beta$ . To show that the region is an interval rather than some more complicated set, one must show that Expression (12) is a monotone function of  $\beta_0$ . Monotonicity is difficult to show analytically. It can be checked numerically by a computer program in any example. In experience so far with real data, (12) has always been monotone for the exponential hazard model, but has not always been monotone with the linear hazard model when the confidence interval was unbounded, or for the Weibull hazard model near  $\beta = -1$ .

To test the hypothesis  $\beta = \beta_0$  for some particular value  $\beta_0$ , the test statistic (12) can be used,

and the hypothesis rejected if the test statistic is in an extreme tail of the normal distribution. In particular, the hypothesis  $\beta = 0$  is often of interest; the test statistic (12) may then have an especially simple form, as discussed below for the examples.

#### Inference for $\lambda_0$

Once a value of  $\beta$  is assumed, it is easy to find a confidence interval for  $\lambda_0$  or confidence intervals for the various  $\lambda_{0j}$ 's. The method is shown here when the components are assumed to have a single common  $\lambda_0$ .

For time-censored data, define  $N = \Sigma N_j$  and  $v = \Sigma v_j$  with  $v$  evaluated at the assumed value of  $\beta$ . Because  $N$  is  $\text{Poisson}(\lambda_0 \Sigma v_j)$ , a two-sided  $100(1 - \alpha)\%$  confidence interval for  $\lambda_0$  is given by Johnson and Kotz (1969, Section 6.2) as

$$\begin{aligned}\lambda_{0L} &= \chi^2_{2n, \alpha/2} / (2v) \\ \lambda_{0U} &= \chi^2_{2(n+1), 1 - \alpha/2} / (2v) .\end{aligned}\tag{13}$$

If instead the data are failure-censored, define  $m = \Sigma m_j$  and  $v = \Sigma v_j$  with  $v$  evaluated at the assumed value of  $\beta$ . Because  $2\lambda_0 V$  has a  $\chi^2(2m)$  distribution, a two-sided  $100(1 - \alpha)\%$  confidence interval for  $\lambda_0$  is given by

$$\begin{aligned}\lambda_{0L} &= \chi^2_{2m, \alpha/2} / (2v) \\ \lambda_{0U} &= \chi^2_{2m, 1 - \alpha/2} / (2v) .\end{aligned}\tag{14}$$

Note that Formulas (13) and (14) agree except for the degrees of freedom.

A two-dimensional confidence region, with confidence coefficient approximately  $100(1 - \alpha)\%$ , can be formed as follows. Form a  $100(1 - \alpha/2)\%$  confidence region for  $\beta$ . At each  $\beta_0$  in the confidence interval, evaluate  $v$  and form the resulting  $100(1 - \alpha/2)\%$  confidence interval for  $\lambda_0$ . The approximation results from the use of a large-sample approximation for the confidence interval for  $\beta$ , and from the way the two individual confidence coefficients are combined to yield a joint confidence coefficient.

If  $\beta$  is treated as known and equal to  $\hat{\beta}$ , Equations (13) or (14) give an approximate confidence interval for  $\lambda_0$ . It is too short, however, because it does not account for the randomness of the estimator  $\hat{\beta}$ . If this interval for  $\lambda_0$  depends strongly on the assumed value of  $\beta$ , a more exact

confidence interval is obtained by taking the largest and smallest values of  $\lambda_0$  in the two-dimensional region for  $(\beta, \lambda_0)$ .

A conservative confidence interval for the hazard function  $\lambda(t)$  is given by the largest and smallest values of  $\lambda(t)$  attained in the two-dimensional confidence region for  $(\beta, \lambda_0)$ .

## 5.2 Inference Based on the Full Likelihood

When all the model parameters are of interest, an analyst either could follow the procedure presented above, or could perform inference based on the full model as follows. The discussion assumes that all the components have a common  $\lambda_0$ . Formulas for  $\lambda_0$  will be based on joint asymptotic normality. There are heuristic arguments for why parameterization in terms of  $\rho = \log \lambda_0$  improves the normal approximation: for failure-censored data, this transformation replaces the scale parameter  $\lambda_0$  by a location parameter; also, the log transformation of Equations (13) and (14) yields more nearly symmetrical intervals.

The log-likelihood  $L(\beta, \lambda_0)$  is given by Equation (4'). The sample information matrix for  $(\beta, \rho) \equiv (\beta, \log \lambda_0)$  is

$$\begin{aligned}
 SI(\beta, \log \lambda_0) &= - \begin{bmatrix} (\partial^2 / \partial \beta^2) L(\beta, \lambda_0) & (\partial^2 / \partial \beta \partial \rho) L(\beta, \lambda_0) \\ (\partial^2 / \partial \beta \partial \rho) L(\beta, \lambda_0) & (\partial^2 / \partial \rho^2) L(\beta, \lambda_0) \end{bmatrix} \\
 &= \Sigma_j \begin{bmatrix} -\{\Sigma_i [\log h(t_{ij})]''\} + \lambda_0 v_j'' & \lambda_0 v_j' \\ \lambda_0 v_j' & m_j \end{bmatrix}. \quad (15)
 \end{aligned}$$

In some situations, evaluation of the above terms at  $(\hat{\beta}, \hat{\lambda}_0)$  is made easier by using the identities  $\Sigma m_j / \hat{\lambda}_0 = \Sigma v_j$  and  $\Sigma \Sigma [\log h(t_{ij})]' = \hat{\lambda}_0 \Sigma v_j'$ , with the second identity following from Equation (8) evaluated at  $(\hat{\beta}, \hat{\lambda}_0)$ .

The information matrix is then defined by

$$I(\beta, \log \lambda_0) = E[SI(\beta, \log \lambda_0)] .$$

The expectation is based on the randomness of  $T_{ij}$  and of either  $V_j$  or  $M_j$ . Depending on the form of

$h$ , the analyst may choose to estimate the information matrix by  $I(\hat{\beta}, \log \hat{\lambda}_0)$  or by  $SI(\hat{\beta}, \log \hat{\lambda}_0)$ ; see Cox and Hinkley (1974, p. 302). In practice, especially when  $V_j$  is random, it is much more convenient to use  $SI$  to estimate  $I(\beta, \log \lambda_0)$ .

Asymptotic inference is based on the fact that  $(\hat{\beta}, \log \hat{\lambda}_0)$  is asymptotically normal with mean  $(\beta, \log \lambda_0)$  and covariance matrix  $I^{-1}(\beta, \log \lambda_0)$ . This allows for approximate confidence intervals for  $\beta$ , for  $\lambda_0$ , and for functions of the two parameters, such as  $\lambda(t)$ . To do the last, write  $\log \hat{\lambda}(t) = \log \hat{\lambda}_0 + \log h(t; \hat{\beta})$ .

Take the first-order Taylor expansion of  $\log h(t; \hat{\beta})$  around  $\hat{\beta} = \beta$ . This yields the asymptotic distribution of  $\log h(t; \hat{\beta})$ , and its asymptotic covariance with  $\log \hat{\lambda}_0$ . Then  $\log \hat{\lambda}(t)$  is asymptotically normal, with mean equal to the sum of the means, and variance equal to the sum of the variances plus twice the covariance. This may be used for  $t$  such that the Taylor approximation is adequate.

### 5.3 Examples

The building blocks for the formulas are all given in Table 1. Asymptotic approximations are also given, to be used when  $\beta$  is near 0 with an exponential or linear hazard function, and when  $\beta$  is near  $-1$  with a Weibull hazard function. Special cases are now considered.

#### Exponential Hazard Function

To test  $\beta = 0$ , based on the conditional log-likelihood, the asymptotic formulas in Table 1 show that the test statistic (12) equals

$$\Sigma_j \left\{ \Sigma_i t_{ij} - n_j \bar{s}_j \right\} / \left[ \Sigma_j n_j r_j^2 / 12 \right]^{1/2} . \quad (16)$$

Here  $i$  goes from 1 to  $n_j$ . When there is just one component ( $j = 1$ ), the statistic becomes

$$\left[ \Sigma_i t_i / n - \bar{s} \right] / \left[ r / (12n) \right]^{1/2},$$

which has a simple intuitive interpretation. If the failure rate is constant ( $\beta = 0$ ), the conditional distribution of the failure times for the component is uniform between  $s_0$  and  $s_1$ . The test statistic is the average observed time minus the midpoint of the observation period, all divided by the standard deviation of an average of uniformly distributed variables. This test was first proposed by Laplace in 1773, according to Bartholemew (1955).

In this case,  $\log\lambda(t) = \log\lambda_0 + \beta t$ . Therefore, the asymptotic distribution of  $\log\hat{\lambda}(t)$  follows neatly from the asymptotic distribution of  $(\hat{\beta}, \log\hat{\lambda}_0)$ .

### Linear Hazard Function

Recall that time-censored data can be centered. This redefines the meaning of  $\lambda_0$  and  $\beta$ , the function  $h(t)$  becomes  $1 + \beta(t - t_{mid})$ , and  $\Sigma v_j'$  equals 0. The sample information matrix (15) then becomes a diagonal matrix, and  $\hat{\beta}$  and  $\hat{\lambda}_0$  are asymptotically uncorrelated.

The test of  $\beta = 0$ , based on the conditional log-likelihood, can be built from the elements in Table 1. The statistic is given by Expression (16). That is, the natural large-sample test of constant failure rate is the same, whether an exponential or linear hazard model is postulated.

The asymptotic distribution of  $\lambda(t)$  is obtained by making the approximation  $\log h(t; \hat{\beta}) \doteq \log(1 + \beta t) + (\hat{\beta} - \beta)t/(1 + \beta t)$ .

The approximation may be used when the second term is small compared to 1. For practical use, the approximation is good enough if twice the standard deviation of  $\hat{\beta}t/(1 + \beta t)$  is less than 0.1, and fair if this standard deviation is less than 0.5.

### Weibull Hazard Function

The necessary expressions are given in Table 1. In this model, the test statistic (12) differs from Expression (16). When all the values of  $s_{0j}$  equal 0, the test statistic simplifies to

$$\{\Sigma \Sigma [\log(t_{ij}/s_{1j}) + 1]\} / (\Sigma n_j)^{1/2}, \quad (17)$$

with  $i$  going from 1 to  $n_j$ . Recall from the discussion of maximum likelihood estimation below Equation (10) that the conditional distribution of  $-\log(T_{ij}/s_{1j})$  is exponential with mean and variance equal to  $1/(\beta + 1)$ , and that the MLE of  $1/(\beta + 1)$  is the sample mean of the terms  $-\log(t_{ij}/s_{1j})$ . Therefore, the negative of the test statistic (17) can be written as the MLE of  $1/(\beta + 1)$  standardized by the mean and variance when  $\beta = 0$ .

The estimated hazard function satisfies  $\hat{\lambda}(t) = \log\hat{\lambda}_0 + \hat{\beta}\log(t/t_0)$ , so the asymptotic normal distribution follows directly from the corresponding result for  $(\hat{\beta}, \log\hat{\lambda}_0)$ .



## 6. DIAGNOSTIC CHECKS

The methods presented above have assumed a common value of  $\beta$  for all components, perhaps a common value of  $\lambda_0$ , and a hazard function of the form  $\lambda_0 h(t; \beta)$ . Computations are often based on the assumption that asymptotic normality yields an adequate approximation. Diagnostic checks—both tests and plots—should be used to investigate the validity of these assumptions.

### 6.1 Common $\beta$

To see if a particular component, the  $k$ th say, has  $\beta$  significantly different from the other components, calculate the MLE based on the  $k$ th component only and on all components (pooled) except the  $k$ th. At this point there is no reason for confidence that the components have a common  $\lambda_0$ ; therefore, use the MLE based on the conditional likelihood, which is independent of the value(s) of  $\lambda_0$ . The difference  $\hat{\beta}_k - \hat{\beta}_{-k}$  has variance equal to the sum of the variances, and mean zero if all components have the same  $\beta$ . Therefore it yields a test, using asymptotic normality, of the hypothesis that the  $k$ th component has the same  $\beta$  as do the others. The  $C$  tests can be combined using the Bonferroni inequality to form an overall test of the hypothesis that the components have a common  $\beta$ . If any component has no nonreplacement failures,  $\beta$  cannot be estimated for that component, and fewer than  $C$  test statistics and confidence intervals can be calculated.

A single component may not have enough failures to justify asymptotic methods. In the extreme case when the  $k$ th component has only one non-replacement failure, a practical expedient is to treat  $\beta_{-k}$  as known, and test whether  $\beta_k = \beta_{-k}$  based on the single observed failure time for the  $k$ th component. This test is based on the fact that the single failure has conditional density  $h(t)/v_k$ , with  $\beta$  set to  $\beta_{-k}$ .

In addition to the test for common  $\beta$ , a useful visual diagnostic is a plot of  $C$  confidence intervals for the parameter, placed side by side, with each interval based on the data from a single component.

### 6.2 Common $\lambda_0$

Suppose that the assumption of a common  $\beta$  is accepted, and consider how to test whether the components have a common  $\lambda_0$ . Treat  $\beta$  as known and equal to  $\hat{\beta}$ ; this introduces an approximation

into the tests for  $\lambda_0$ , but it does not a priori treat any component differently from any other. Consider now the  $k$ th component, pool all the components except the  $k$ th, and test whether  $\lambda_{0k}$  equals  $\lambda_{0,-k}$ . Assume for the moment the null hypothesis that the components have a common  $\lambda_0$ .

With time-censored data, the conditional distribution of  $N_k$ , conditional on the ancillary statistic  $\Sigma n_j$ , is binomial( $\Sigma n_j, p_k$ ), with  $p_k = v_k(\beta)/\Sigma v_j(\beta)$ . This yields a test of the hypothesis that  $\lambda_{0k}$  is the same as  $\lambda_0$  for the other components. These tests may be combined with the Bonferroni inequality. Alternatively, if the failure counts are not too small, a  $\chi^2$  test may be used, based on the fact that  $(N_1, \dots, N_c)$  is multinomial  $(\Sigma n_j, p_1, \dots, p_c)$ .

With failure-censored data, the distribution of  $2\lambda_0 V_k(\beta)$  is  $\chi^2(2m_k)$ , and the sum of the observation periods for all components except the  $k$ th is likewise proportional to a  $\chi^2$  random variable. Therefore the ratio of  $V_k$  to the sum of such terms over all components except the  $k$ th is proportional to an  $F$  random variable. This yields a test of the hypothesis that  $\lambda_{0k}$  is the same as  $\lambda_0$  for the other components. The tests may be combined with the Bonferroni inequality.

As when comparing the components for  $\beta$ , a side-by-side plot of confidence intervals for  $\lambda_{0j}$  provides useful visual diagnostic information.

### 6.3 Form of $h(t)$

To test whether  $h$  is of the assumed form, use the fact that for the  $j$ th component, conditional on the observed failure count  $n_j$  or on the final observation time  $s_{1j}$ , the  $T_{ij}$ 's are independent and for each component are identically distributed, with density proportional to  $h$ , as discussed below Equation (5'). Therefore, under the assumed model, the conditional probability that a random failure  $T$  occurs by time  $t$  is

$$\begin{aligned} P[T \leq t] &= \sum_j P[T \leq t \mid \text{failure is in component } j] P[\text{failure is in component } j] \\ &= \sum_j P[T \leq t \mid \text{failure is in component } j] (n_j / \Sigma n_i) . \end{aligned}$$

with

$$\begin{aligned} P[T \leq t \mid \text{failure is in component } j] &= [H(t) - H(s_{0j})]/v_j && \text{if } s_{0j} \leq t \leq s_{1j} \\ &= 0 && \text{if } t < s_{0j} \\ &= 1 && \text{if } t > s_{1j} . \end{aligned}$$

Tests for a hypothesized distribution may now be used, such as the Kolmogorov-Smirnov test or the

Anderson-Darling test.

Routine use of one of these tests gives a Type I error smaller than the nominal value; the test tends not to reject often enough. There are two reasons for this. One is the familiar reason that the estimated value of  $\beta$  must be used to evaluate  $H$  and  $v$ . The second reason arises if the components are observed over different time periods. The distribution used is conditional on the failure counts or final failure times, so the  $T_{i,j}$ 's are not truly a random sample. As an extreme example, suppose that component 1 was observed for only the first year of its life and that it had  $n_1$  failures, that component 2 was observed for only the second year of its life and that it had  $n_2$  failures, and so forth. The conditional distribution then says that of  $\sum n_j$  failures in the first  $C$  years, on the average  $n_i$  will occur in year  $i$ . The  $T_{i,j}$ 's are a stratified sample from this distribution, and are therefore forced to fit the distribution rather well. They fit well regardless of the form of  $h$ , because the stratification does not involve the hypothesized  $h$ .

To avoid this difficulty, it is good to try to use components that are observed over the same time period; if a few components have a different observation window from all the others, try partitioning the data and performing the test on the two sets separately. In the extreme case given by the above example, the following method could be used. Find  $\hat{\beta}$  using all the data, and treat it as known. Then for each of the  $C$  components perform a separate Kolmogorov-Smirnov test of  $H_0: \beta = \hat{\beta}$ . This yields  $p_1, \dots, p_C$ , the attained significance levels or  $p$ -values. It is well-known that under  $H_0$ , a  $p$ -value is uniformly distributed on  $(0, 1)$ , so that  $-2\sum \log(p_j)$  has a  $\chi^2(2C)$  distribution. Thus  $H_0$  would be rejected at level  $\alpha$  if  $-2\sum \log(p_j) > \chi^2_{1-\alpha}(2C)$ .

Two pictures may accompany the test. One is the plot of the above model-based c.d.f. overlaid with the empirical c.d.f.. The other is a Q-Q plot, as described, for example, by Snee and Pfeifer (1983). It plots the  $n$  observed failure times versus the inverse of the model-based c.d.f. evaluated at  $1/(n+1), \dots, n/(n+1)$ .

#### 6.4 Adequacy of Asymptotic Normal Approximation

An MLE can be inspected to see if it is near the mid-point of a two-sided confidence interval; if not, the normal approximation may not be adequate. Also, a two-dimensional confidence region for  $(\beta, \log \lambda_0)$  can be constructed from an interval for  $\beta$  and conditional intervals for  $\lambda_0$  given  $\beta$ , as

discussed below Equation (14). This can then be compared to the confidence ellipse based on the asymptotic joint normality of  $(\hat{\beta}; \log \hat{\lambda}_0)$ . If the two regions are very different, approximate joint normality should be questioned.

## 7. EXAMPLE DATA ANALYSIS

A nuclear power plant for a commercial utility has 12 motor-operated valves in the auxiliary feedwater systems at the two units of the plant. Maintenance records covering about 10 years were examined, and the failure times for the valves were tabulated. The data are summarized in Table 2, and are given in more detail by Wolford et al. (1990). Three valves were replaced upon failure, and one was replaced for administrative reasons, leading to 16 valves shown in Table 2. The three valves that were replaced upon failure were regarded as failure-censored. The other 13 valves were regarded as time-censored. A Fortran program PHAZE (for Parametric HAZard Estimation) was written and used on a personal computer to analyze the data, following the methods of this report; the program is documented by Atwood (1990).

The valves were first compared to see if they have clearly different values of  $\beta$ . Figure 1 shows a side-by-side plot of the confidence intervals based on the individual components. It also shows the significance levels based on a comparison of  $\hat{\beta}_k$  to  $\hat{\beta}_{-k}$ . The diamond in each confidence interval shows  $\hat{\beta}_k$  while the square shows  $\hat{\beta}_{-k}$ . Note that there is no estimate or interval for components with no non-replacement failures. The overall significance level, based on the Bonferroni combination of the individual significance levels, is 1.0, confirming the pictorial impression that there is no real difference in  $\beta$  for the various components. The exponential hazard function was assumed for these calculations. The results were similar when the linear or Weibull hazard function was assumed. The only striking difference was that many of the MLEs and all of the upper confidence limits were infinite with the linear hazard function. A similar comparison of the components for  $\lambda_0$  led to a conclusion that the components do not have greatly different values of  $\lambda_0$ . Therefore, the components were assumed to have a common value of  $\beta$  and of  $\lambda_0$ .

Tests of  $\beta = 0$  were performed based on the test statistic (12), and the hypothesis was rejected in favor of  $\beta > 0$ . The test based on  $\Sigma \Sigma t_{ij}$ , when Expression (12) takes the form of Expression (16), rejected at one-sided level 0.021. The test based on  $\Sigma \Sigma \log t_{ij}$ , when Expression (12) is evaluated under the Weibull model, rejected at one-sided level 0.025.

Table 2. Summary of example data

Component	Nonrepl. Fails.	Observed Hrs.	Mean Failure Time (Normed)	Replaced on Fail.?	Initial Age (Hrs.)
MOV-1A	1	8.8584E+04	0.378		4.1448E+04
MOV-1B	1	8.8584E+04	0.086		4.1448E+04
MOV-1C	2	8.8584E+04	0.752		4.1448E+04
MOV-1D	7	8.8584E+04	0.743		4.1448E+04
MOV-1E	0	2.1840E+04		Y	4.1448E+04
MOV-1E(R)	3	6.6744E+04	0.498		0.0000
MOV-1F	3	4.3608E+04	0.568	Y	4.1448E+04
MOV-1F(R)	1	4.4976E+04	0.487		0.0000
MOV-2A	4	8.8584E+04	0.619		3.7824E+04
MOV-2B	5	8.8584E+04	0.567		3.7824E+04
MOV-2C	1	4.9728E+04	0.756	Y	3.7824E+04
MOV-2C(R)	1	3.8856E+04	0.866		0.0000E-01
MOV-2D	6	8.8584E+04	0.464		3.7824E+04
MOV-2E	0	2.2608E+04			3.7824E+04
MOV-2E(R)	2	6.5976E+04	0.698		0.0000
MOV-2F	7	8.8584E+04	0.593		3.7824E+04

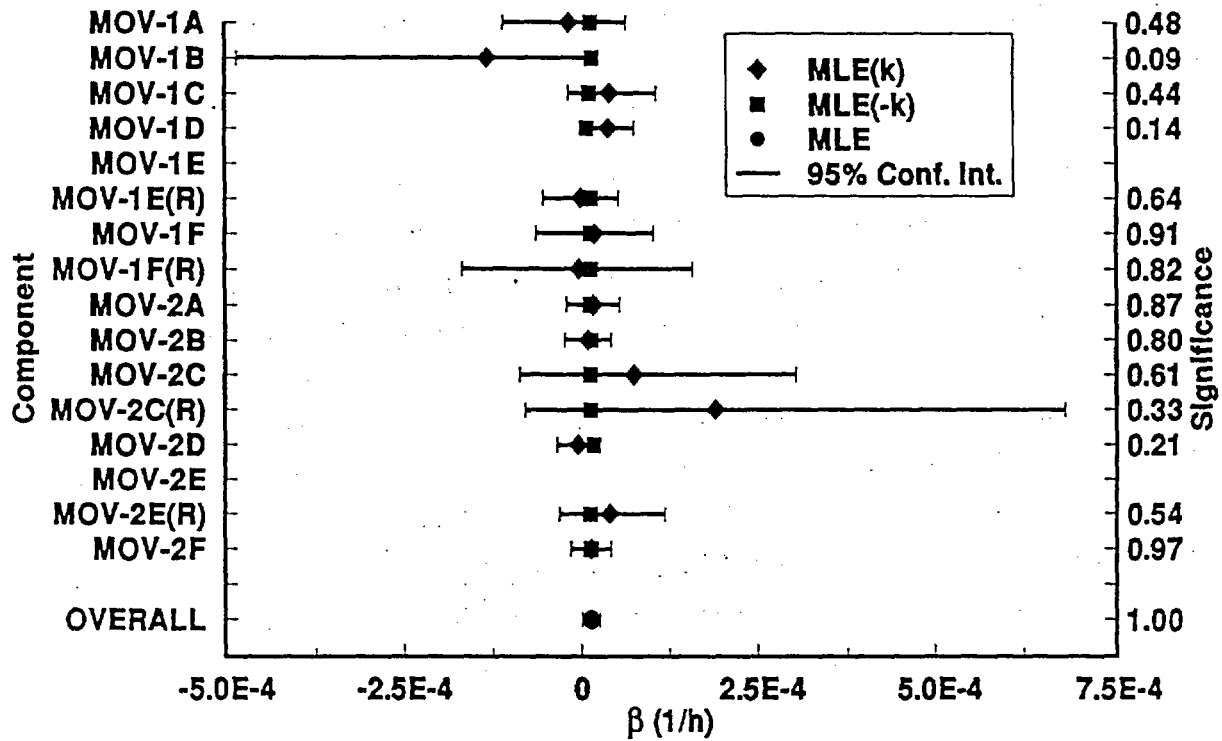


Figure 1. Component Comparisons for  $\beta$ , Exponential Hazard Model

To test the form of the model, the Kolmogorov-Smirnov test was performed, as described in Section 6.3. The test saw nothing wrong with any of the three models; the three significance levels were all greater than 0.8. To account for the partial stratification of the data, the components were partitioned into two groups, the twelve that were in place at the start of observation, and the four that were installed during the observation period. The overall MLE, based on the conditional likelihood for all the components, was used to estimate  $\beta$ . This value was treated as known in the two data sets, and the Kolmogorov-Smirnov test was used to test the fit of each data set to each of the three models. The three significance levels corresponding to the larger data set were calculated using asymptotic formulas and were all greater than 0.79; the significance levels corresponding to the smaller data set (seven failures) were not calculated exactly but were all substantially greater than 0.20. Even allowing for the fact that the hypothesized model had an estimated parameter, it seems that the data give no reason to question any of the three models.

Figure 2 shows the Q-Q plot of the full data set, based on the exponential hazard model. Q-Q plots based on the other models look similar. The only evident departure from the assumed model is shown by several strings of nearly vertical dots, indicating repairs that cluster in time. The effect of this clustering is ignored below.

For each model, an approximate two-dimensional 90% confidence region was found for  $(\beta, \log \lambda_0)$ , as discussed below Equation (14). Similarly, a 90% confidence ellipse was found based on the asymptotic normality of  $(\hat{\beta}, \log \hat{\lambda}_0)$ . These two regions are superimposed in Figure 3 for the exponential hazard function, and in Figures 4 and 5 for the linear and Weibull hazard functions. The circle and the ellipse show the MLE and the confidence region based on the full likelihood and asymptotic normality, while the square and the non-elliptical region show the MLE and confidence region based on the conditional likelihood. For the linear model the data were centered, and for the Weibull model the normalizing  $t_0$  was set to  $t_{mid}$ . For the exponential and Weibull models, the regions overlap fairly well, suggesting that the asymptotic distribution is an adequate approximation. For the linear hazard function, the confidence regions must be truncated at the maximum allowed value for  $\beta$ . Therefore the normal approximation is not adequate. By the way, when the linear hazard model was used with uncentered data, the confidence regions were as shown in Figure 6. The non-elliptical region is thin and strongly curved, and it hardly overlaps the truncated ellipse at all; therefore, centering seems to improve the normal approximation, even though the approximation still is inadequate.

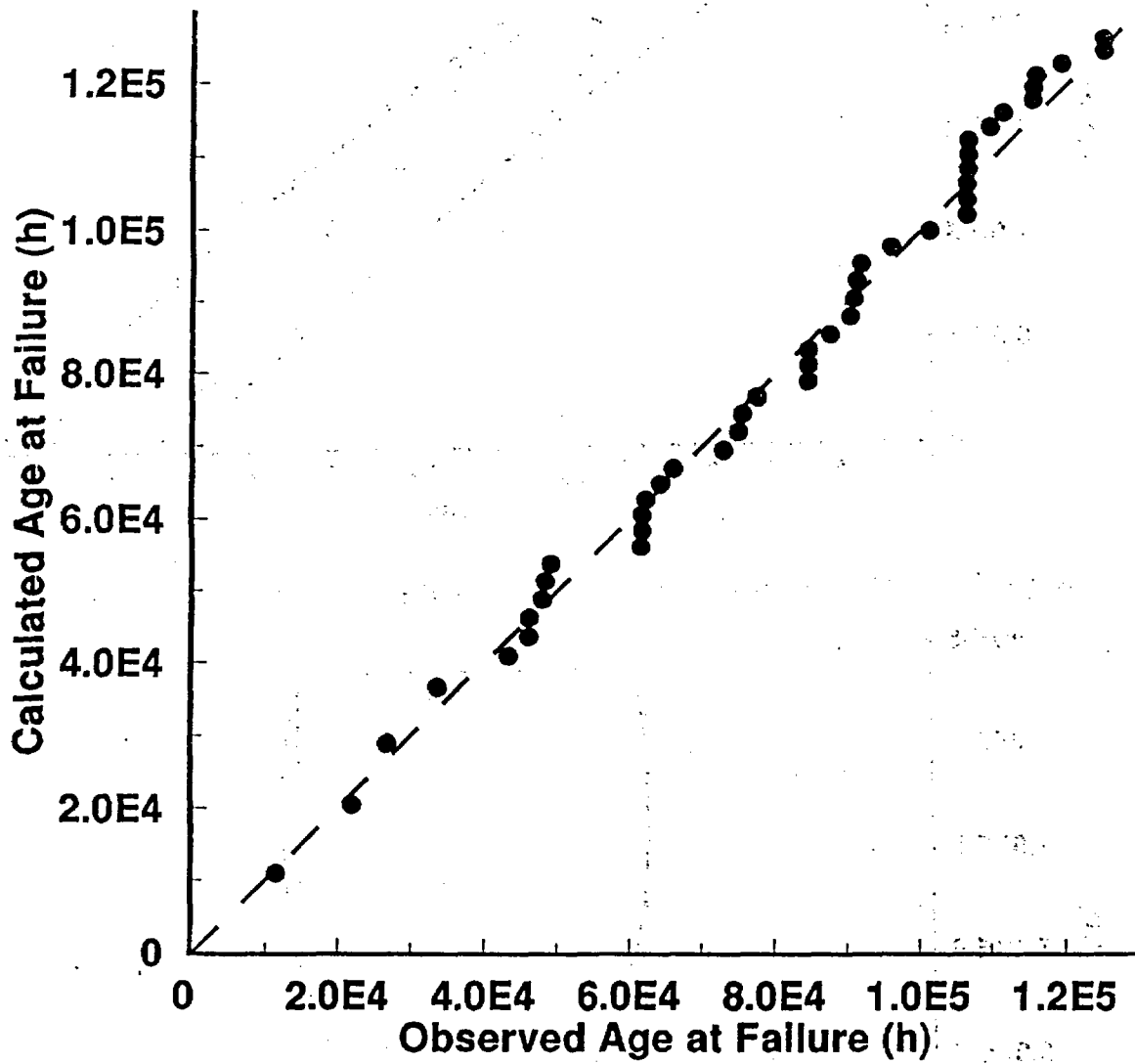


Figure 2. Q-Q Plot for Exponential Hazard Model

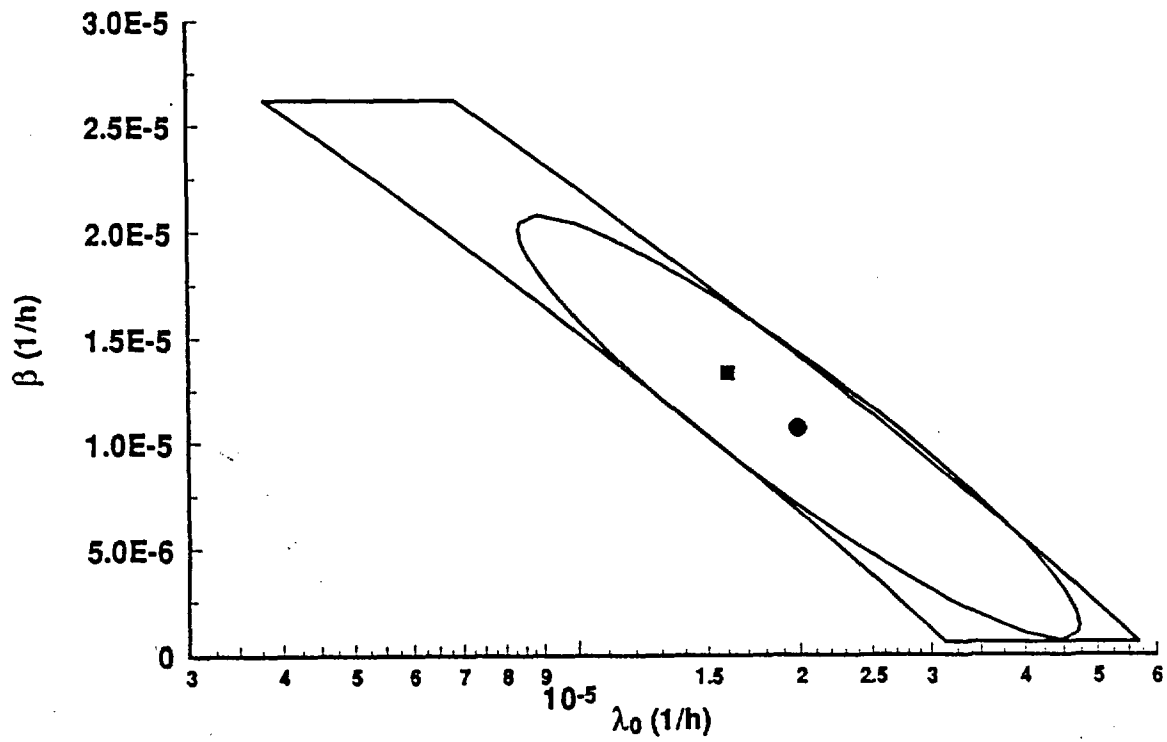


Figure 3. 90% Confidence Regions for  $(\beta, \lambda_0)$ , Based on Exponential Hazard Model

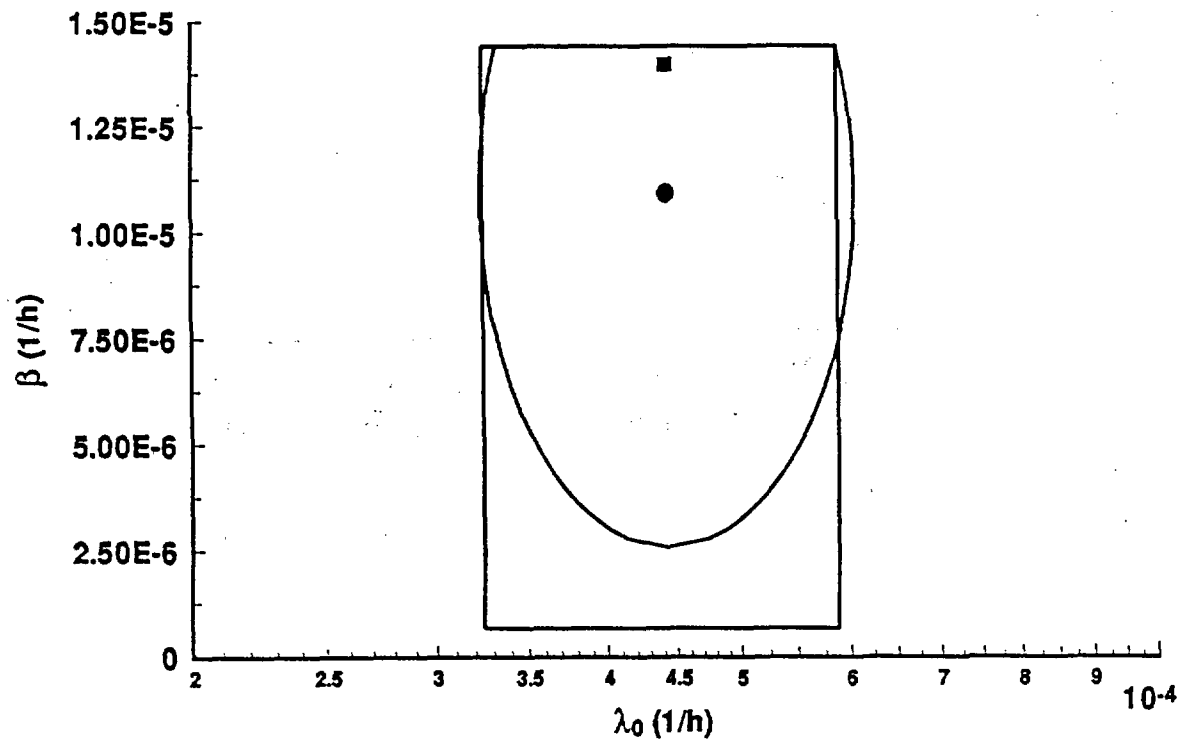


Figure 4. 90% Confidence Regions for  $(\beta, \lambda_0)$ , Based on Linear Hazard Model, Centered Data



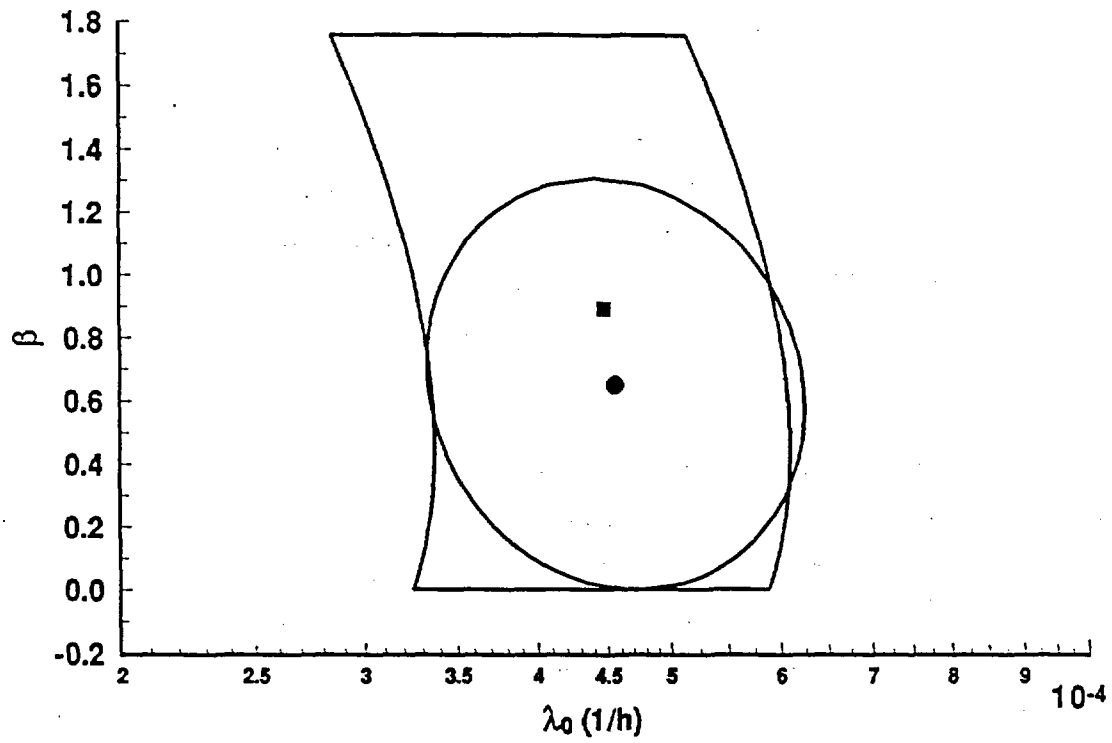


Figure 5. 90% Confidence Regions for  $(\beta, \lambda_0)$ , Based on Weibull Hazard Model, Uncentered Data

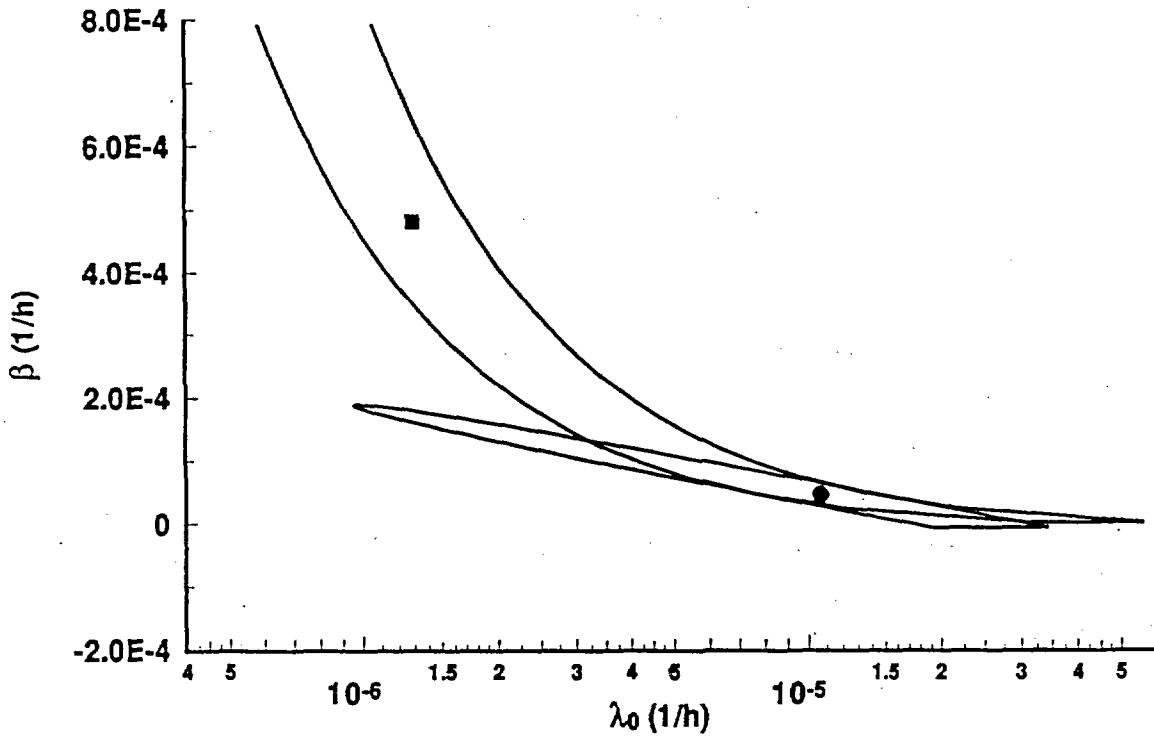


Figure 6. 90% Confidence Regions for  $(\beta, \lambda_0)$ , Based on Linear Hazard Model, Uncentered Data

Finally, the hazard function was estimated with a confidence interval based on the asymptotic joint normal approximation. In spite of the poorness of the joint normal approximation for the linear hazard model, the method was used for all three models, for comparative purposes. Figure 7 shows the MLE and 90% confidence interval for  $\lambda(t)$ , at various values of  $t$ , for the three models. If the confidence band for the linear hazard model were seriously advocated, it would be plotted only for values of  $t$  satisfying

$$2 \text{ sd } t / (1 + \hat{\beta}t) < 0.5,$$

where  $\text{sd}$  is the estimated standard deviation of  $\hat{\beta}$ ; outside this range, the first-order Taylor approximation of  $\log h(t; \beta)$  is inadequate. This restriction corresponds to requiring  $t > 1.6E4$  h. If the upper and lower bounds for the linear model are ignored where  $t < 1.6E4$  h, the bands for the three models look similar, except that the Weibull hazard function approaches 0 at time 0. Most of the components were observed between ages  $4.1E4$  h and  $13.0E4$  h. It is not surprising that the confidence intervals are narrowest [in the scale of  $\log \lambda(t)$ ] in the middle of this period of the observed data. If the model were extrapolated far beyond the data, the uncertainties would become very large.

## 8. DERIVATIONS AND PROOFS

The likelihood formulas developed here have long been known; for example, see Equations (2.1) and (3.1) of Boswell (1966), or Bain et al. (1985). The derivations are sketched here for completeness. Consider a single component. The fundamental idea to be used repeatedly here is that the transformation

$$u(t) = \Lambda(t) - \Lambda(s_0)$$

converts the non-homogeneous Poisson process to a homogeneous one with unit rate. That is, the count of events occurring at transformed times  $u(t)$  with  $u(a) \leq u(t) \leq u(b)$  is Poisson with parameter  $u(b) - u(a)$ , and counts for disjoint intervals are independent. For such a homogeneous process, it is well known that the time between successive events is exponential with parameter 1.0. Likelihood formulas may be derived using the relation between the density of  $t$ , denoted by  $f$ , and the density of  $u(t)$ , denoted by  $g$ :

$$f(t) = g[u(t)] |\partial u(t) / \partial t| = \exp[-u(t)] \lambda(t)$$

$$f(t_i | t_{i-1}) = g[u(t_i) | u(t_{i-1})] \lambda(t_i) = \exp[u(t_{i-1}) - u(t_i)] \lambda(t_i) .$$

Here,  $f(t_i | t_{i-1})$  is the conditional density of a failure at time  $t_i$ , conditional on the component's being operable (restored to service) at time  $t_{i-1}$ .

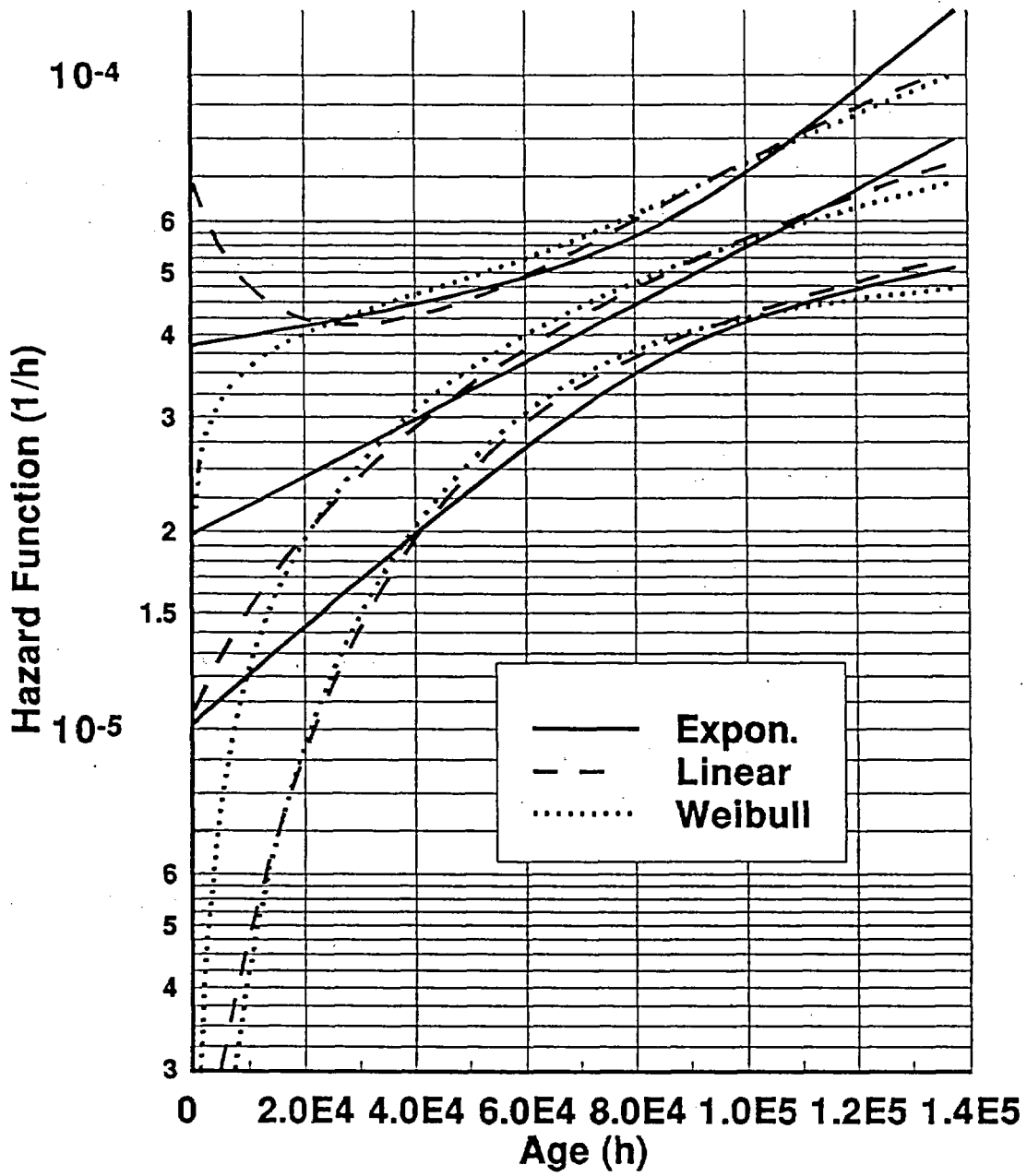


Figure 7. MLE and 90% Confidence Band for  $\lambda(t)$ , Based on Three Models

## 8.1 Derivation for Time-Censored Data

### The Likelihood

Consider a single component and suppress the subscript  $j$  and the argument  $\beta$ . Suppose that a random number of failures is observed in a fixed time interval  $[s_0, s_1]$ , and that the ordered failure times are  $t_1, \dots, t_n$ . In the formulas below, define  $t_0 = s_0$  and  $u_i = u(t_i)$ . Note that  $u(s_0) = 0$  and  $u(s_1) = \lambda_0 v$ . The likelihood is the joint density of the observed failure times, multiplied by the probability of no failures after  $t_n$ ; that is,

$$\begin{aligned}
 l_{full}(\beta, \lambda_0) &= \left[ \prod_1^n f(t_i | t_{i-1}) \right] \exp[\Lambda(t_n) - \Lambda(s_1)] \\
 &= \left[ \prod_1^n \lambda(t_i) \right] \left[ \prod_1^n \exp(u_{i-1} - u_i) \right] \exp[u_n - u(s_1)] \\
 &= \lambda_0^n \left[ \prod_1^n h(t_i) \right] \exp(-\lambda_0 v), \tag{18}
 \end{aligned}$$

Taking logs and summing over the components yields Equation (4), as claimed.

For a single component, consider now the conditional distribution of the failure times given  $n$ . Because  $N$  is Poisson( $\lambda_0 v$ ), the probability of  $n$  failures is

$$\exp(-\lambda_0 v) (\lambda_0 v)^n / n! . \tag{19}$$

Therefore the conditional likelihood, the likelihood corresponding to the conditional distribution of  $t_1, \dots, t_n$  given  $n$ , is the quotient of Expression (18) divided by Expression (19):

$$l_{cond}(\beta) = \left[ \prod_1^n h(t_i) \right] (v)^{-n} n! .$$

Taking logs and summing over components yields Equation (5), as claimed.

### Ancillarity

Consider again a single component. The failure count  $N$  is ancillary for  $\beta$ . To see this, define  $\mu = \lambda_0 v$ . Reparameterize so that the parameters defining the model are  $\mu$  and  $\beta$ . Then  $N$  is Poisson( $\mu$ ), so the distribution of  $N$  involves only  $\mu$ , not  $\beta$ . Given  $N = n$ , the unordered failure times  $T_i$  are i.i.d., each with density  $h(t)/v$  on the interval  $[s_0, s_1]$ . This conditional density depends on  $\beta$

only, not on  $\mu$ . Therefore,  $N$  is ancillary for  $\beta$  and  $(T_1, \dots, T_n)$  is conditionally sufficient for  $\beta$ .

Suppose now that there are  $C$  components,  $C > 1$ , and that the components are not assumed to have a common value of  $\lambda_0$ . Then  $(N_1, \dots, N_C)$  forms a  $C$ -dimensional ancillary statistic for  $\beta$ . This is easily shown by a generalization of the above argument for a single component, parameterizing the model in terms of  $\beta$  and  $(\mu_1, \dots, \mu_C)$ , with  $\mu_j = \lambda_{0j}v_j$ .

Similarly, suppose that there are  $C$  components with a common value of  $\lambda_0$ , and that  $v_j$  has the same value  $v$  for all the components, regardless of  $\beta$ . (Remark: In the three examples of this report, this can occur only if the components all have a common value of  $s_0$  and  $s_1$ . To see this, set  $v_j = v_k$  and  $v_j' = v_k'$ . Evaluate these quantities at  $\beta = 0$  using the formulas of Table 1. It follows that  $s_{0j} = s_{0k}$  and  $s_{1j} = s_{1k}$ ; this is immediate for the exponential and linear hazard function, and can be shown with a little effort for the Weibull hazard function.) Now set  $\mu = \lambda_0v$  and note that  $N = \sum N_j$  is Poisson( $C\mu$ ). Consider the conditional log-likelihood analogous to Expression (5), only now conditional on  $n$  rather than on  $(n_1, \dots, n_C)$ . It is equal to

$$\log\{(n!)C^n \prod_{j=1}^C \prod_{i=1}^{n_j} [h(t_{ij})/v]\} .$$

This is the log of the conditional density of the ordered failure times, with each time assigned at random to one of the  $C$  components. Therefore, the  $T_{ij}$ 's are conditionally i.i.d., each with conditional density  $h(t)/v$  for  $s_0 \leq t \leq s_1$ . The components may therefore be pooled as a single super-component, and  $N = \sum N_j$  is ancillary for  $\beta$ .

Finally, suppose that there are  $C$  components,  $C > 1$ , that the  $v_j$ 's are not all equal, and that the components are assumed to have a common value of  $\lambda_0$ . There does not seem to be a reparameterization such that the distribution of  $(N_1, \dots, N_C)$  is independent of  $\beta$ . Therefore  $(N_1, \dots, N_C)$  does not appear to be ancillary. To show conclusively that  $(N_1, \dots, N_C)$  is not ancillary, we note that Equations (6) and (8) yield different values of  $\hat{\beta}$ .

## 8.2 Derivation for Failure-Censored Data

Now suppose that a single component is observed starting at time  $s_0$ , and that  $m$  failures are observed, with  $m$  fixed. The full likelihood is the joint density of the failure times:

$$\begin{aligned}
l_{full}(\beta, \lambda_0) &= \left[ \prod_1^m f(t_i | t_{i-1}) \right] \\
&= \left[ \prod_1^m \lambda(t_i) \right] \exp(u_0 - u_m) \\
&= \lambda_0^m \left[ \prod_1^m h(t_i) \right] \exp(-\lambda_0 v).
\end{aligned} \tag{20}$$

Taking logs and summing yields Equation (4).

To condition on the value  $t_m$ , the distribution of  $T_m$  must first be derived.

**THEOREM.** The time to the  $m$ th failure  $T_m$  has density

$$f_m(t_m) = w^{m-1} e^{-w} \lambda(t_m) / (m-1)! \tag{21}$$

where  $w = \Lambda(t_m) - \Lambda(s_0)$ , and  $t_m \geq s_0$ .

**COROLLARY.** Define  $\lambda_0 V$  by  $\Lambda(T_m) - \Lambda(s_0)$ . Then  $2\lambda_0 V$  has a  $\chi^2(2m)$  distribution.

**PROOF OF THEOREM.** Here,  $w = u(t_m)$ , the  $m$ th transformed failure time. Because the transformed failure times correspond to a Poisson process with unit rate, it is well known that the  $m$ th transformed time has a gamma distribution. The asserted result follows.  $\square$

The conditional distribution of  $(T_1, \dots, T_m)$  given  $T_m = t_m$  is (20) divided by (21). Take logs and sum over the components to show that  $L_{cond}(\beta)$  is exactly equal to Expression (5).

## 9. REFERENCES

Corwin L. Atwood, *User's Guide to PHAZE, a Computer Program for Parametric Hazard Function Estimation*, EGG-SSRE-9017, 1990.

Lee J. Bain, Max Engelhardt, and F. T. Wright, "Tests for an Increasing Trend in the Intensity of a Poisson Process: A Power Study," *Journal of the American Statistical Association*, 80, 1985, pp. 419-422.

D. J. Bartholomew, Discussion of article by D. R. Cox, *Journal of the Royal Statistical Society, Series B*, 17, 1955, pp. 162-163.

M. T. Boswell, "Estimating and Testing Trend in a Stochastic Process of Poisson Type," *Annals of Mathematical Statistics*, 37, 1966, pp. 1564-1573.

D. R. Cox and D. V. Hinkley, *Theoretical Statistics*, London: Chapman and Hall, 1974.

D. R. Cox and Valerie Isham, *Point Processes*, London: Chapman and Hall, 1980.

D. R. Cox and P. A. W. Lewis, *The Statistical Analysis of Series of Events*, London: Chapman and Hall, 1966.

D. R. Cox and D. Oakes, *Analysis of Survival Data*, London: Chapman and Hall, 1984.

William Feller, *An Introduction to Probability Theory and Its Applications, Volume I*, Third Edition, New York: John Wiley & Sons, 1968.

Norman L. Johnson and Samuel Kotz, *Discrete Distributions*, New York: John Wiley & Sons, 1969.

Norman L. Johnson and Samuel Kotz, *Continuous Univariate Distributions - 1*, New York: John Wiley & Sons, 1970a.

Norman L. Johnson and Samuel Kotz, *Continuous Univariate Distributions - 2*, New York: John Wiley & Sons, 1970b.

John D. Kalbfleisch, "Ancillary Statistics," *Encyclopedia of Statistical Sciences*, Vol. 1, S. Kotz and N. L. Johnson, eds., New York: John Wiley & Sons, 1982.

Alan F. Karr, "Poisson Processes," *Encyclopedia of Statistical Sciences*, Vol. 7, S. Kotz and N. L. Johnson, eds., New York: John Wiley & Sons, 1986.

Paul L. Meyer, *Introductory Probability and Statistical Applications*, Reading MA: Addison-Wesley, 1970.

Wayne Nelson, *Applied Life Data Analysis*, New York: John Wiley & Sons, 1982.

Anthony A. Salvia, "Maximum Likelihood Estimation of Linear Failure Rate," *IEEE Transactions on Reliability*, R-29, 1980, pp. 49-50.

Ronald D. Snee and Charles G. Pfeifer, "Graphical Representation of Data," *Encyclopedia of Statistical Sciences*, Vol. 3, S. Kotz and N. L. Johnson, eds., New York: John Wiley & Sons, 1983.

William E. Vesely, *Risk Evaluations of Aging Phenomena: the Linear Aging Reliability Model and Its Extensions*, NUREG/CR-4769, EGG-2476, 1987.

Andrew J. Wolford, Corwin L. Atwood, and W. Scott Roesener, *Aging Risk Assessment Methodology: Demonstration Study on a PWR Auxiliary Feedwater System*, NUREG/CR-5378, EGG-2567, DRAFT, Rev. 1, 1990.

Stephen Wolfram, *Mathematica: A System for Doing Mathematics by Computer*, Redwood City, CA: Addison-Wesley Publishing Company, 1988.



**Appendix B**  
**Tables of Maintenance Records**

---

**Table B.1**  
**Maintenance Records for**  
**Auxiliary Feedwater System**

Table B.1.a. MAINTENANCE RECORDS FOR THE AUXILIARY FEEDWATER SYSTEM TURBINE DRIVEN FEED PUMPS

MARK NO.	COMPONENT	M. R. #	PROBLEM DESC	MODE/MECHANISM(if applicable) HISTORY SUMMARY	RTSVDT	CLASSIFICATION*
1-TDP	PUMP	801010430	GROSS OIL-LOW DISCHARGE PRESSURE	RENEWED THRUST BEARING LININGS	780111	FR
1-TDP	PUMP	803030420	EXCESSIVE DISCHARGE PREE-PT15	REDUCED SPEED OF PUMP AT GOVERNOR	780303	FR
1-TDP	VALVE	10176160	BODY TO BONNET LEAK	RENEWED BONNET GASKET	780508	BL
1-TDP	PUMP	901030450	GOV VALVE WILL NOT CONTROL PUMP SPEED	FIXED SATISFACTORY	790204	FR
2-TDP	PUMP	901261550	REFUEL PMS	DID PMS CHECKS	790228	PMS
1-TDP	TURB	810040500	VARIOUS REPAIRS	REPAIRED AND TESTED GOVERNOR TRIP VALVE	790420	FR
2-TDP	PUMP	902131328	OIL COOLER END BELL CRACKED	VOID	790420	VOID
1-TDP	PUMP	905021900	DRAIN, CLEAN, INSPECT SUMP REFILL	DRAINED OIL, CLEANED SUMP	790515	PMS
1-TDP	PUMP	905181332	SIGHT GLASS HAS OIL LEAK	TIGHTENED SIGHT GLASS	790611	MD
1-TDP	PUMP	902040100	HEAD GASKET LEAKS ON PUMP	VOID	790917	VOID
1-TDP	PUMP	905101032	ADJUST PACKING	VOID	790917	VOID
1-TDP	TURB	811030530	GOVERNOR VALVE INOPERATIVE	VOID	791002	VOID
1-TDP	INSTR	910201310	REPLACE GAUGE AND REPAIR LEAK	REPLACED GAUGE	791102	GAUGE
1-TDP	PUMP	911011230	OIL LEAK ON PUMP	REPAIRED PUMP AND HELD PM CHECK	791116	MD
2-TDP	PUMP	902201305	PMS AS PER MMP-P-FW-004	VOID	791128	VOID
1-TDP	VALVE	910201305	REPLACE HANDWHEEL	FOUND HANDWHEEL TO BE PROPERLY INSTALLED	791209	MD
1-TDP	PUMP	912172125	OUTBOARD PUMP BEARING THROWING OIL	RENEWED THRUST BEARING	791223	FR
1-TDP	PUMP	1240708	OIL SEAL PACKING LEAK	RENEWED THRUST SHOE	800210	FR
2-TDP	INSTR	2191428	DEFICIENCY PUNCH LIST	REPLACED GLASS	800319	MD
1-TDP	INSTR	4131129	BROKEN CASE SWITCH	INSTALLED NEW SWITCH	800429	FR
2-TDP	PUMP	7221245	PUMP HAS AUTOMATIC SIGNAL	VOID - WORK PERFORMANCE ON MR 2007221802	800725	VOID
1-TDP	VALVE	903271145	REWORK GOV VALVE AND OVERSPEED TRIP	VOID - DONE UNDER ANOTHER MR	800828	VOID
2-TDP	PUMP	8300800	FIND AND REPAIR OIL LEAKS	TIGHTENED OIL FITTINGS	800830	MD
2-TDP	INSTR	11010524	CALIBRATE	CAL GAUGES, REPLACED SUCTION GAUGE	801104	GAUGE
2-TDP	PUMP	11170730	OVERSPEED TRIP VALVE TRIPS	STRAIGHTENED LINKAGE	801118	FR
2-TDP	MOTOR	102080443	MOTOR TORQUES OUT	CLEANED TORQUE SWITCH CONTACTS	810208	NFF
1-TDP	PUMP	102091232	PERFORM MMP-FW-005	PERFORM PREVENT MAINT SERVICE ON PUMP	810218	PMS
2-TDP	INSTR	103030900	CHECK CALIBRATION OF GAUGE	INSTALLED NEW GAUGE, OLD ONE IS GOOD	810304	GAUGE
1-TDP	INSTR	102270712	REPAIR FLEX CONDUIT	MADE CORRECTIONS TO PS-FW-152	810317	MD
1-TDP	PUMP SEAL	103091251	OUTBOARD SEAL LEAKS EXCESS	REPLACED ONE RING & PACKING	810331	BL
1-TDP	VALVE	7270315	TRIP VALVE	VOID - THIS HAS ALREADY BEEN WORKED	810430	VOID
2-TDP	GAUGE	105110915	INSTALL NEW PRESSURE GAUGE	INSTALLED NEW GAUGE	810520	GAUGE
2-TDP	PUMP	105231115	LEAK ON SUCTION PACKING GLAND	TIGHTENED PACKING	810531	BL
1-TDP	TURBINE	105130010	D/C 80-S88 ISOLATION OF AUX FEEDWATER	INSTALLED LINE AS PER D/C	810604	DC

\* PMS - PREVENTIVE MAINTENANCE BL - BOUNDARY LEAK VOID - VOIDED MD - MINOR DEFICIENCY GAUGE - GAUGE REPLACEMENT OR CALIBRATION  
 DC - DESIGN CHANGE FR- FAILURE TO RUN FS - FAILURE TO START NFF - NON-FUNCTIONAL FAILURE

B-5

Table B.1.a. (continued)

MARK NO.	COMPONENT	M. R. #	PROBLEM DESC	MODE/MECHANISM(if applicable) HISTORY SUMMARY	RTSVDT	CLASSIFICATION*
1-TDP	INSTR	106081328	GAUGE MISSING - REPLACE	REPLACED MISSING GAUGE	810611	GAUGE
1-TDP	TURBINE	107080847	CHANGE OIL	VOID - DONE ON ANOTHER MR	810708	VOID
2-TDP	VALVE	107190318	VALVE DOESN'T FULLY CLOSE	ADJUSTED LIMIT SWITCH	810723	NFF
1-TDP	TURBINE	109271530	INSPECT TERRY TURBINE	COMPLETE	810930	PMS
2-TDP	INSTR	110010900	CALIBRATE OR REPLACE GAUGES	CALIBRATED GAUGES	811006	GAUGE
2-TDP	VALVE	102111400	OVERSPEED TRIP VALVE	VOID	811014	VOID
2-TDP	PUMP	8301025	FIND AND REPAIR OIL LEAKS	VOID - TO BE UPDATED	811022	VOID
1-TDP	TURB	7110905	PERFORM PMS	VOID	811028	VOID
1-TDP	PUMP	110200400	EXCESSIVE PACKING	ADJUSTED PACKING AND PUMP STILL LEAKS	811029	BL
2-TDP	PUMP	8210243	OIL LEAK ON TURBINE OUTBOARD	VOID - UNABLE TO FIND LEAK	811123	VOID
1-TDP	VALVE	112061246	DIAPHRAGM LEAK	STOPPED DIAPHRAGM LEAK	811209	NFF
1-TDP	VALVE	112230958	VALVE INDICATES OPEN	ADJUSTED LIMITS AND PRESSURE SWITCH	811224	NFF
1-TDP	SWITCH	110210224	PRESSURE SWITCH MALFUNCTIONING	VOID	820104	VOID
2-TDP	PUMP	102120300	OIL LEAK	COMPLETE	820104	MD
2-TDP	PUMP	110091528	PERFORM MMP-P-FW-004	VOID	820105	VOID
2-TDP	PUMP	7110907	PERFORM PMS	VOID	820106	VOID
1-TDP	PUMP	112160430	MANUAL TRIP LEVER	VOID	820108	VOID
2-TDP	PUMP	201060807	RESET THRUST BEARING CLEARANCE	RESET THRUST CLEARANCE BY CHARGING	820128	PMS
2-TDP	PUMP	201060812	RESET THRUST BEARING CLEAR	RESET THRUST CLEARANCE	820223	PMS
2-TDP	VALVE	112051530	POSITION LIGHT INDICATES OPEN	NO PROBLEMS FOUND	820301	VOID
1-TDP	INSTR	202231420	STEAM DRIVEN PUMP SUCTION GAUGE	REPLACED GAUGE	820310	GAUGE
1-TDP	PUMP	204261123	REPACK INBOARD END OF PUMP	VOID - COMPLETED ON MRS 0204240356	820427	VOID
1-TDP	PUMP	204240356	PUMP SEAL BENT, PUMP AND TURB LEAKING	ADJUSTED PACKING	820428	BL
2-TDP	PUMP	205081945	GOVERNOR SET AT 4060 RPM	RESET RPM TO 3880	820513	FR
2-TDP	PUMP	205271700	CRACK IN WELD	REPLACED PIPE	820527	NFF
1-TDP	PUMP	206161054	CHANGE OUT GOVERNOR	CHANGED OUT GOVERNOR	820621	DC
2-TDP	PUMP	206161053	CHANGE OUT GOVERNOR	REPLACED WITH NEW GOVERNOR	820621	DC
1-TDP	PUMP	207212001	EXCESSIVE PACKING LEAK ON OUTBOARDS	ADJUSTED PACKING	820723	BL
1-TDP	TURB	207211430	FIND AND REPAIR CAUSE OF TERRY TURBINE	VOID	820809	VOID
1-TDP	GLASS	208081600	OIL LEVEL SITE GAUGE LEAKING	TIGHTENED TOP AND BOTTOM OF SIGHT GLASS	820816	MD
2-TDP	SIGHTGLA	208132143	REPLACE OIL SIGHT GLASS	INSPECTED SIGHT GLASS FOR LEAK FOUND	820823	MD
1-TDP	PUMP	208132145	REPAIR OIL LEAK	CHANGED THRUSTED SHAFT COLLAR JOURNAL	820824	FR
2-TDP	VALVE	209031049	POSITION LIGHTS INDICATE INTERM VALVE	ADJUSTED LIMITS FOR	820908	NFF
2-TDP	SWITCH	209101905	LIMIT SWITCH NOT INDICATING VALVE O	ADJUSTED LIMITS ON SOV	820910	NFF

\* PMS - PREVENTIVE MAINTENANCE    BL - BOUNDARY LEAK    VOID - VOIDED    MD - MINOR DEFICIENCY    GAUGE - GAUGE REPLACEMENT OR CALIBRATION  
 DC - DESIGN CHANGE    FR- FAILURE TO RUN    FS - FAILURE TO START    NFF - NON-FUNCTIONAL FAILURE

B-6

Table B.1.a. (continued)

MARK NO.	COMPONENT	M. R. #	PROBLEM DESC	MODE/MECHANISM(if applicable) HISTORY SUMMARY	RTSVOT	CLASSIFICATION*
2-TDP	PUMP	209092200	PUMP OUTBOARD BEARING THROWS OIL	VOID - COMPLETED ON MR 2209092200	820916	VOID
1-TDP	GAUGE	210141057	REPLACE OIL PRESSURE GAUGES TO BEARING	REPLACED GAUGE WITH	821014	GAUGE
1-TDP	PUMP	211060800	ADJUST OIL PRESSURE RELIEF	ADJUSTED OIL PRESSURE RELIEF	821109	MD
1-TDP	INSTR	211060852	CALIBRATE PRESSURE GAUGE	CHECKED GAUGE, CALIBRATED	821109	GAUGE
1-TDP	INSTR	211102345	REPLACE BEARING OIL PRESSURE GAUGES	INSTALLED GAUGE AND	821112	GAUGE
2-TDP	GAUGE	211102343	REPLACE BEARING OIL PRESSURE	INSTALLED GAUGE AND	821112	GAUGE
2-TDP	PUMP	211102100	OIL PRESS REGULATOR NEEDS TO BE ADJ	RESET OIL PRESSURE REGULATOR	821115	MD
1-TDP	BOTTLE	211091807	CHANGE OUT NITRO BOTTLES	REPLACED NITRO-2 BOTTLE	821120	MD
1-TDP	BOTTLE	211280901	CHANGE N2 BOTTLE	REPLACED N2 BOTTLE AND	821129	MD
2-TDP	GOVERNOR	212061305	REPAIR FEEDBACK ARM	REINSTALLED SETSCREW	821207	FR
2-TDP	PUMP	211151410	COUPLING GUARD MISSING	INSTALLED COUPLING	821210	MD
2-TDP	PUMP	212070837	PACKING LEAK	INSTALLED ONE RING OF	821212	BL
1-TDP	PUMP	212230847	REPLACE NITROGEN	REPLACED NITROGEN BOTTLE	821228	MD
1-TDP	BOTTLE	212300500	REPLACE N2 BOTTLE	REPLACED NITROGEN BOTTLE	830110	MD
2-TDP	GAUGE	301140952	DISCHARGE GAUGE NEEDS CALIBRATING	CHECKED SATISFACTORY	830117	GAUGE
1-TDP	PUMP	302050907	N2 BOTTLE PRESSURE LOW	CHANGED N2 BOTTLES	830209	MD
2-TDP	PUMP	302111050	PUMP TRIPS	ADJUSTED OVERSPEED TRIP	830216	FR
2-TDP	PUMP	303101430	SET SCREW MISSING	ADJUSTED DAMPER	830314	FR
2-TDP	PUMP	303181232	OVERSPEED TRIP	PUT SPRING BACK ON HOOK	830321	FR
1-TDP	PACKING	211112045	REPACK, ADJUST AUX FEEDWATER PUMP	VOID - COMPLETED NO 1211061159	830404	VOID
1-TDP	PUMP	211061159	PUMP NEEDS REPACKING	REPACKED PUMP	830404	BL
1-TDP	INDICATOR	303091559	LEAKING CONNECTION BET PIPE AND PRES	TIGHTENED AND TAPED	830418	BL
1-TDP	PUMP	304011235	TEN YEAR HYDRO	INSPECTION COMPLETE	830428	PMS
2-TDP	PUMP	304250400	OIL SEAL LEAKING	REPLACED BEARING AND THREAD SLOES	830429	FR
1-TDP	GAUGE	305042040	CHECK CALIBRATION	REPLACED GAUGE WITH	830511	GAUGE
1-TDP	BOTTL	307212225	REPLACE NITROGEN BOTTLE	REPLACED NITROGEN BOTTLE	830726	MD
1-TDP	GAUGE	308110835	GAUGE NEEDS RECALL	CLEANED + CALIBRATED GAUGE	830813	GAUGE
1-TDP	GAUGE	308110834	GAUGE NEEDS RECALL	CLEANED + CALIBRATED GAUGE	830813	GAUGE
2-TDP	PUMP	308291127	OIL POSSIBLY CONTAMINATED	CHANGE OIL	830912	MD
1-TDP	PUMP	309200751	HANGER MISSING	MADE AND INSTALLED HANGER	830923	MD
2-TDP	BEARING	306200726	REPLACE BEARING	REPLACED BEARING AND SHOES	830927	FR
1-TDP	GAUGE	305311605	REPLACE GAUGE	INSTALLED NEW CAL GAUGE	831004	GAUGE
1-TDP	N2 BOTTL	310030700	REPLACE NITROGEN BOTTLES	CHANGED NITROGEN BOTTLES	831006	MD
2-TDP	PUMP	309271700	HIGH BEARING VIBRATIONS	ADJUSTED LINKAGE	831013	FR

\* PMS - PREVENTIVE MAINTENANCE BL - BOUNDARY LEAK VOID - VOIDED MD - MINOR DEFICIENCY GAUGE - GAUGE REPLACEMENT OR CALIBRATION  
 DC - DESIGN CHANGE FR - FAILURE TO RUN FS - FAILURE TO START NFF - NON-FUNCTIONAL FAILURE

Table B.I.a. (continued)

MARK NO.	COMPONENT	M. R. #	PROBLEM DESC	MODE/MECHANISM(if applicable) HISTORY SUMMARY	RTSVDT	CLASSIFICATION*
1-TDP	VALVE	310272330	CAP LEAKING	TIGHTENED CAP ON CHECK VALVE	831031	BL
1-TDP	PUMP	310221306	OUTBOARD LEAKS 1-TDP	VOID - TO BE DONE ON MR 0310301600	831101	VOID
1-TDP	PUMP	310301600	REPACK PUMP	CHECKED LEAK RATE	831104	BL
1-TDP	PUMP	306200725	OIL LEAK	VOID	831107	VOID
2-TDP	GAUGE	311210152	PLACE DAMPENERS IN LINE	INSTALLED FLOW OSCILLATOR	831122	DC
1-TDP	PUMP	310201430	PUMP HAS LOW DELTA PRESSURE	VOID - NOT A PROBLEM	840103	VOID
1-TDP	VALVE	401040826	CLEAN AND GREASE VALVE STEM	CLEANED & LUBRICATED	840109	PMS
2-TDP	VALVE	401040811	CLEAN AND GREASE VALVE STEM	CLEANED & LUBRICATED	840109	PMS
1-TDP	PMP GOV	312311328	REPAIR GOVERNOR	INSTALLED NEW SEAT	840111	FR
1-TDP	PUMP	402171445	REPLACE N2 BOTTLE	REMOVED & REPLACED BOTTLE	840222	MD
1-TDP	PUMP	403030615	TRIP VALVE LEAKS EXCESSIVELY	NO PROBLEM	840305	VOID
2-TDP	SWITCH	402240947	PUMP WILL NOT CUT OFF IN AUTO	CHECKED SWITCH	840330	FR
2-TDP	GAUGE	404051830	GAUGE MISSING	INSTALLED NEW GAUGE	840427	GAUGE
1-TDP	PUMP	307211530	BEARING HAS NON-QUALIF THRUST COLLAR	REPLACED NON QUALIFIED THRUST COLLAR	840517	MD
2-TDP	PUMP	406121600	MANUFACTURE 2 COUPLINGS	MANUFACTURED 6 COUPLINGS	840613	PMS
1-TDP	PUMP	11029	REPLACE NITROGEN BOTTLE	VOID - AS PER SHIFT SUPERVISOR.	850103	VOID
1-TDP	PUMP	12360	REPLACE OIL SLINGER RING	VOID - TO BE COMPLETED ON WO 012350.	850207	VOID
1-TDP	PUMP	14061	MECHANICAL LINKAGE BROKEN	REINSERTED ROD AND CLOSED SOCKET ENDS AROUND BALL TIP.	850214	FR
1-TDP	PUMP	13659	REPLACE BROKEN GAUGE	REPLACE GAUGE.	850314	GAUGE
2-TDP	PUMP	13711	REPLACE PRESS GAUGE 2-TDP	REPLACE GAUGE	850314	GAUGE
1-TDP	PUMP	13660	REPLACE BROKEN GAUGE GLASS	INSTALLED NEW CALIBRATED GAUGE.	850315	GAUGE
2-TDP	PUMP	20077	INVEST/REPAIR SOV-MS-A/B	BOTH VALVES ARE OPEN WITH OPEN INDICATION IN CONTROL ROOM ON BOTH VALVES NO WORK PERFORMED	850620	VOID
1-TDP	PUMP	12350	OUTBOARD BEARING THROWS OIL	VOID - WORK COMPLETED ON WO 004170.	850726	VOID
1-TDP	PUMP	22684	REPAIR OUTBOARD BEARING SEAL LEAK	REPLACED GASKET, MANUFACTURED OIL PAPER.	850809	MD
1-TDP	PUMP	21903	TIGHTEN OUTBOARD PKG GLAND	REPACKED PUMP, ONE-HALF PACKING USED, SHOP SPARE.	850809	BL
2-TDP	PUMP	23379	PUMP INOPERABLE, REPAIR	REMOVED INBOARD AND OUTBOARD BEARING CAPS- FOUND BOTH JOURNAL BEARINGS IN GOOD CONDITION- OUTBOARD THRUST BEARING -THRUST SHOES- WIPED AND ROLLED OVER WITH BABBITT. ALIGNMENT	850819	FR
1-TDP	PUMP	23564	INVESTIGATE/REPAIR PUMP 1-TDP	VOID - NOT REQUIRED AS PER ATTACHED MEMO.	851213	VOID

B-8

\* PMS - PREVENTIVE MAINTENANCE    BL - BOUNDARY LEAK    VOID - VOIDED    MD - MINOR DEFICIENCY    GAUGE - GAUGE REPLACEMENT OR CALIBRATION  
 DC - DESIGN CHANGE    FR- FAILURE TO RUN    FS - FAILURE TO START    NFF - NON-FUNCTIONAL FAILURE

Table B.1.a. (continued)

MARK NO.	COMPONENT	M. R. #	PROBLEM DESC	MODE/MECHANISM(if applicable) HISTORY SUMMARY	RTSVDT	CLASSIFICATION*
1-TDP	PUMP	24333	INVESTIGATE/REPAIR PUMP 1-TDP	VOID - NOT REQUIRED AS PER ATTACHED MEMO.	851213	VOID
1-TDP	PUMP	28462	REPLACE N2 BOTTLE	REPLACED NITROGEN BOTTLE.	851223	MD
2-TDP	PUMP	28719	REPLACE NITROGEN BOTTLE	CHANGED OUT NITROGEN BOTTLE IAW PROCEDURE.	860102	PMS
2-TDP	PUMP	28865	ADJUST PACKING GLANDS	TIGHTENED OUTBOARD GLAND ONE FLAT LEAK STOPPED 100%. TIGHTENED INBOARD END 3 FLATS LEAK DECREASED TO 20 DROPS PER MIN.	860106	DC
1-TDP	PUMP	29554	CHANGE OUT BOTTLE	REMOVED EMPTY BOTTLE, INSTALLED NEW BOTTLE (2100PSI), CHECKED FITTINGS FOR LEAKS. TESTED SATISFACTORY.	860120	MD
2-TDP	PUMP	28417	INVEST/ADJUST GOVERNOR RPM	VOID NO PROBLEM DURING PT	860121	VOID
1-TDP	PUMP	29443	CHANGE OUT BOTTLE	VOID - WORK PERFORMED ON EMERGENCY WO 029544.	860122	VOID
2-TDP	PUMP	28172	-I-INSPECT FOR BLOCKAGE	REMOVED OIL COOLER FROM SYSTEM TESTED FOR BLOCKAGE. NO BLOCKAGE FOUND. REINSTALLED IN SYSTEM	860224	PMS
2-TDP	PUMP	31029	REPLACE NITROGEN BOTTLE	REPLACE NITROGEN BOTTLE	860224	PMS
1-TDP	PUMP	32273	VOID TO WO 031510	VOID - COMPLETED ON WO 031510.	860318	VOID
1-TDP	PUMP	26976	P-REPLACE GLAND STUDS/NUTS	PACKING LEAK/NORMAL WEAR UNCLOGGED DRAIN LINES, REPLACED PACKING GLAND STUDS, REPACKED INBOARD SIDE OF PUMP. 4 RINGS OF PACKING USED. SHAFT SLEEVE IS WORN.	860509	BL
1-TDP	PUMP	27017	P-REPAIR OIL LEAKS	BAD BEARINGS/INSUFF. OIL FLOW REPLACED BEARINGS, THRUST BEARINGS, AND REPACKED PUMP.	860509	FR
1-TDP	PUMP	27016	ADJUST/REPACK GOV VALVE	INSPECTED GOVERNOR. STEM IS SEALED BY LEAK OFF-CHANNELS, NO ADJUSTMENT AVAILABLE. VALVE TO BE OVERHAULED ON WR 352517.	860512	BL
1-TDP	PUMP	37655	PERFORM CTS 87-86	VOID - NOT REQUIRED.	860627	VOID
1-TDP	PUMP	33554	CALIBRATE/REPLACE GAUGE	REPLACED GAUGE.	860706	GAUGE
1-TDP	PUMP	38556	CHECK INSTRUMENTS	OUT OF CAL/TIME & USE. GAUGES WERE EACH: OIL PRESSURE, 1 OIL TEMP, 1 PUMP SUCTION, 1 PUMP DISCHARGE, AND 1 STEAM PRESSURE.	860715	GAUGE
2-TDP	PUMP	21964	INVEST/REPAIR HI DISCH PRESS.	VOID WORK NOT REQUIRED	860715	VOID
1-TDP	PUMP	38507	OVERHAUL AUX FEED PUMP	BROKEN PART INTERNAL/OVER PRESSURIZATION DISASSEMBLED PUMP, REPLACED IMPELLERS, DIFUSERS, AND BEARINGS. TESTED PUMP AND RAN SATISFACTORY.	860718	NAF

\* PMS - PREVENTIVE MAINTENANCE    BL - BOUNDARY LEAK    VOID - VOIDED    MD - MINOR DEFICIENCY    GAUGE - GAUGE REPLACEMENT OR CALIBRATION  
DC - DESIGN CHANGE    FR- FAILURE TO RUN    FS - FAILURE TO START    NFF - NON-FUNCTIONAL FAILURE    NAF - NOT AN AGING FAILURE (MAINTENANCE ERROR)

Table B.1.a. (continued)

MARK NO.	COMPONENT	M. R. #	PROBLEM DESC	MODE/MECHANISM(if applicable) HISTORY SUMMARY	RTSVDT	CLASSIFICATION*
1-TDP	PUMP	38591	INVESTIGATE/REPAIR TERRY TURBINE	WORN BEARINGS/NORMAL USE DISASSEMBLED WORN BEARINGS, AND REPLACED WORN JOURNAL BEARINGS (.060).	860718	NAF
1-TDP	PUMP	36784	PERFORM EWR 85-544	REMOVED PIPING AND INSTALLED 3-1/2 PIPE PLUGS.	860721	PMS
1-TDP	PUMP	38639	INSTALL SPOOL PIECE	REMOVED TRAINER FROM PIPE, REINSTALLED PIPE.	860721	PMS
1-TDP	PUMP	35392	P-OVERHAUL GOVERNOR	VOID - WORK WAS PERFORMED ON TURBINE AND MOTOR, NO PROBLEM FOUND WITH GOVERNOR VALVE.	860807	VOID
1-TDP	PUMP	4170	INVESTIGATE PUMP BEARING LEAK	BROKEN SLINGER/THRUSTING	860820	FR
1-TDP	PUMP	39823	REPLACE BEARINGS AS REQUIRED	REPLACED SLINGER, BEARINGS, WEAR RINGS, BALANCE WIPED THRUST SHOES/IMPROPER SET THRUST UNCOUPLED PUMP, TOOK ALIGNMENT CHECK AND CHECKED THRUST, REMOVED BEARING HOUSING OUTBOARD THAT WAS FOUND INBOARD.	860821	NAF
1-TDP	PUMP	40056	ASSIST TECH REP AS REQUIRED	ASSIST TECH REP VERIFIED PROPER LINKAGE SETTINGS ON GOVERNOR LINKAGE.	860828	PMS
1-TDP	PUMP	40487	SPRING REPLACEMENT	GOVERNOR VALVE NOT OPEN ALL THE WAY, SUSPECT BAD SPRING. REMOVED OLD SPRING AND REPLACED WITH NEW SPRING. OPS DID AN OPERABILITY TEST AND GOVERNOR VALVE IS STILL NOT OPENING.	860907	FR
1-TDP	PUMP	40494	GOVERNOR ADJUSTMENT	REMOVED BONNET AND ROTATED 90 DEGREES TO PUT FLAT MACHINED SURFACE TO NORTH POSITION. READJUSTED LINKAGE AND TEST RAN PUMP.	860907	MD
1-TDP	PUMP	41325	OPEN, INSPECT, REPAIR GOV VALVE	VALVE GOV LEAK THRU/STEAM CUT SEATS REMOVE LINKAGE AND VALVE FORM SYSTEM. FOUND BODY TO BE STEAM CUT ON SEATS. AS WE REMOVED BUSHING TEST RAN PUMP IAW OPS PT. TEST SAT, NO REPAIR REQUIRED 9/24/86	860927	FR
2-TDP	PUMP	41215	ASSIST TECH REP AS REQUIRED	LINKAGE/IMPROPER SET	860929	PMS
1-TDP	PUMP	40454	ADJUST GOVERNOR VALVE LINKAGE	DISCONNECTED LINKAGE L2 AND L1, REMOVED PIN FROM SHAFT L1, SET STEAM GOVERNOR VALVE, LOOSENED FISHER REGULATING SPRING AND SET AT 3/8.	860930	FR
1-TDP	PUMP	41324	ADJUST LINKAGE. HIGH DISCHARGE	VOID - COMPLETED ON WO 041325.	860930	VOID
1-TDP	PUMP	40488	REPAIR OVERSPEED TRIP	VALVE CHECKED FOR FREEDOM OF MOVEMENT, FOUND TO BE STICKING APPROXIMATELY 50% IN THE CLOSED POSITION. VALVE DISASSEMBLY REVEALED HEAVY WEAR AND SOME STEAM CUTS TO GUIDE.	860930	FR

\* PMS - PREVENTIVE MAINTENANCE    BL - BOUNDARY LEAK    VOID - VOIDED    MD - MINOR DEFICIENCY    GAUGE - GAUGE REPLACEMENT OR CALIBRATION  
 DC - DESIGN CHANGE    FR - FAILURE TO RUN    FS - FAILURE TO START    NFF - NON-FUNCTIONAL FAILURE    NAF - NOT AN AGING FAILURE (MAINTENANCE ERROR)



Table B.1.a. (continued)

MARK NO.	COMPONENT	M. R. #	PROBLEM DESC	MODE/MECHANISM(if applicable) HISTORY SUMMARY	RTSVDT	CLASSIFICATION*
1-TDP	PUMP	40491	VALVE LINKAGE ADJUSTMENT	WE FOUND THE LINKAGE OUT OF ADJUSTMENT AND GOVERNOR LEVER HAD EXCESS WEAR. WE REMOVED THE OLD LINKAGE AND GOVERNOR LEVERS, REPLACING SAME WITH NEW LEVERS. THE NEW LEVERS HAD	860930	FR
2-TDP	PUMP	38609	REFURBISH ROTATING ASSY.	ROTOR ASSY. HAS BEEN REFURBISHED AND IS LOCATED IN THE WAREHOUSE.	861001	PMS
1-TDP	PUMP	40418	INVESTIGATE, REPAIR T/T VALVE	INSPECT/INSPECT STRAINER REMOVED VALVE FROM SYSTEM, CLEANED SEATING AND GASKET SURFACES. FOUND GASKET SURFACE STEAM CUT, WELD REPAIRED STEAM CUT.	861005	BL
1-TDP	PUMP	41217	ASSIST TECH REP AS REQUIRED	ASSISTED TECH REP IN RUNNING PUMP AND MAKING MINOR ADJUSTMENTS.	861008	PMS
1-TDP	PUMP	39931	BEARING REPAIR	VOID - NOT REQUIRED AS PER ENGINEER.	861114	VOID
2-TDP	PUMP	44339	2-TDP EWR 86-452	TFE IN TWO DRAIN LINES INTO TURBINE CASING WHERE AN EXISTING PLUG IS NOW. WELD CONDENSATE POTS IN EXHAUST STEAM TURBINE.	861131	DC
2-TDP	PUMP	26975	REPLACE PCKG GLND BOLTS	REMOVED OLD STUDS AND NUTS. INSTALLED NEW STUDS AND NUTS PUMP REPLACED UNDER WO 041407	861201	MD
2-TDP	PUMP	44993	OVERHAUL GOVERNOR VALVE	LEAKS/WEAR REMOVED GOVERNOR VALVE FROM TURBINE. BOTH SEATS WERE BAD AND HAD TO BE REPLACED. REPLACED PLUG AND STEM. REPLACED FLANGE GASKETS.	861201	PMS
2-TDP	PUMP	41408	-P, L- OVERHAUL TURBINE	OVERHAUL/WEAR. REMOVED LAGGING AND UNCOUPLED TURBINE FROM PUMP. REPLACED ALL BEARINGS AND BUSHINGS ON TURBINE. REMOVED WHEEL AND FOUND IT TO BE WORN.	861201	PMS
2-TDP	PUMP	46180	TEST CASING SENTINEL VALVE	TEST/OVERHAUL. REMOVED VALVE FROM SYSTEM AND TRANSPORTED TO INSTRUMENT SHOP CAL. LAB. SET UP ON TEST STAND AND VALVE STARTED LIFTED AT 2 PSI ADJUSTED TO	861203	PMS
2-TDP	PUMP	41407	-P- OVERHAUL PUMP	REMOVED OLD ROTATING ASSEMBLY FOUND THRUST BRG WIPED-ONE SET OF SHOES WRONG FOR SIDE USED, OUTBOARD BEARINGS WORN FROM THRUST BRG	861211	PMS
1-TDP	PUMP	47554	CHANGE OIL	DRAINED OIL FROM RESEVOIR. REMOVED COVER PLATE, WIPED OUT WITH LINT FREE DIAPER AND REFILLED WITH NON-PARFIL TURBINE OIL APPROX 17 GALS.	861229	PMS
1-TDP	PUMP	40126	REPAIR/REPLACE GOVERNOR VALVE	VOID - WORK PERFORMED UNDER WO 055496.	861230	VOID
1-TDP	PUMP	41624	PACKING REPLACEMENT/REPAIR	VOID - PUMP PERFORMED SATISFACTORY ON VOID - NO LEAK AS PER WALKDOWN.	861230	VOID

\* PMS - PREVENTIVE MAINTENANCE    BL - BOUNDARY LEAK    VOID - VOIDED    MD - MINOR DEFICIENCY    GAUGE - GAUGE REPLACEMENT OR CALIBRATION  
DC - DESIGN CHANGE    FR - FAILURE TO RUN    FS - FAILURE TO START    NFF - NON-FUNCTIONAL FAILURE

Table B.1.a. (continued)

MARK NO.	COMPONENT	M. R. #	PROBLEM DESC	MODE/MECHANISM(if applicable) HISTORY SUMMARY	RTSVDT	CLASSIFICATION*
2-TDP	PUMP	45013	IMPLEMENT BWR 86-452	VOID TO 44339	870205	VOID
2-TDP	PUMP	48794	-P- REPR/REPL CONNECTING ROD	UNIT 2-FW-T-2 OVERHAULED DURING 1986 REFUELING OUTAGE. OVERSPEED TEST WAS PERFORMED DEC 1986 SATISFACTORILY. INSPECTED LINKAGE WITH VOID - WORK ORDER CREATED TO OBTAIN PARTS ONLY.	870225	PMS
1-TDP	PUMP	44576	REFURBISH ROTATING ASSEMBLY	VOID - NOT LEAKING AS PER OPS RUN.	870207	VOID
1-TDP	PUMP	49060	P-REPLACE END BELL GASKET	VOID - TO 049601	870220	VOID
1-TDP	PUMP	40557	VALVE REPLACEMENT	LEAK/WEAR	870302	BL
1-TDP	PUMP	49601	REPLACE OIL COOLER FLANGE GASKET	MANUFACTURED NEW GASKET AND INSTALLED ON COOLER.		
1-TDP	PUMP	44074	REPLACE SIGHT GLASS	BROKEN SIGHT GLASS/ACCIDENT REMOVED OLD SIGHT GLASS THAT WAS BROKEN, DRAINED OIL OUT OF SUMP AND CLEANED, QC. CLOSED OUT. REPLACED SIGHT GLASS.	870304	MD
1-TDP	PUMP	51012	INSTALL COUPLING GUARD	NO FAILURE. INSTALLED COUPLING GUARD. CHECKED TO BE SURE COUPLING WILL NOT RUB WHEN ROTATING.	870316	MD
1-TDP	PUMP	52935	REPAIR LEAK	MACHINERY HAS BEEN FRESHLY PAINTED. NO LEAK. PAINTERS WERE STILL PAINTING ON MACHINERY. PAINT HAS SEALED PREVIOUS LEAK.	870526	BL
1-TDP	PUMP	54171	TIGHTEN/REDOPE FITTING	OIL LEAKAGE/LOOSE CAP FOUND UNION WAS NOT LEAKING. THE CAP ON A 3/4-CHECK VALVE LEADING TO THE SUCTION SIDE OF THE LUBE OUL PUMP WAS LEAKING. TIGHTENED.	870615	MD
1-TDP	PUMP	48005	1-TDP, EWR 86-553	INSTALLED VENT LINE AND VALVE IN THE EMERGENCY WATER SUPPLY LINE CONNECTING THE FIRE PROTECTION MAIN TO THE SUCTION LINES OF THE AUX FW PUMPS.	870716	DC
1-TDP	PUMP	48003	1-TDP ADD DRAIN LINES	INSTALLED DRAINS ON UNIT 1 TURBINE DRIVER AUX FW PUMP FOR STEAM EXHAUST, STEAM RING AND TURBINE CASING.	870716	DC
1-TDP	PUMP	48004	1-TDP EWR 86-554	INSTALLED VENTS AND VALVE IN THE EMERGENCY WATER SUPPLY LINE CONNECTING THE EMERGENCY MAKE-UP TANK TO THE SUCTION LINES OF THE AUX FW PMPS.	870716	DC
2-TDP	PUMP	44338	2-TDP EWR 86-443	INSTALLED A VENT ON THE FIRE PROTECTION SYSTEM SUPPLY HEADER 6- WCMU-108-151	870716	DC
2-TDP	PUMP	56858	CAL/REPLACE GAUGE	CHECKED GAGE, GAGES WAS IN CAL. AND HAD A STICKER NO FURTHER WORK REQUIRED.	870918	GAUGE

\* PMS - PREVENTIVE MAINTENANCE    BL - BOUNDARY LEAK    VOID - VOIDED    MD - MINOR DEFICIENCY    GAUGE - GAUGE REPLACEMENT OR CALIBRATION  
 DC - DESIGN CHANGE    FR- POTENTIAL FAILURE TO RUN    FS - FAILURE TO START    NFF - NON-FUNCTIONAL FAILURE

Table B.1.b. MAINTENANCE RECORDS FOR THE AUXILIARY FEEDWATER SYSTEM MOTOR DRIVEN FEED PUMPS

MARK NO.	COMPONENT	M. R. #	PROBLEM DESC	MODE/MECHANISM(if applicable) HISTORY SUMMARY	RTSVDT	CLASSIFICATION*
2-MDP-A	PMP MTR	803091354	CHANGE OIL	CHANGED OIL AND CHECKED BEARINGS	780330	PMS
2-MDP-B	PUMP	20170210	HEADBOLTS 1 2 AND 1 6 LEAK	INSTALLED SEALANT MATERIAL	780330	BL
2-MDP-A	PUMP	804030936	LUBE OIL RES LEVEL INDICATOR BROKE	INSTALLED DIPSTICK ARRANGEMENT	780404	MD
2-MDP-B	PMP MTR	803091355	CHANGE OIL	CHANGED OIL AND REPLACED BEARING	780406	PMS
2-MDP-B	PUMP	804061450	COUPLING GUARD MISSING	REINSTALLED GUARD	780407	MD
2-MDP-A	PMP MTR	901261800	REMOVE HEAT LAMPS	REMOVED HEAT LAMPS	790129	DC
2-MDP-B	PUMP	902050137	PUMP START NOT SATISFACTORY	TIME DELAY TESTED SATISFACTORY	790207	FS
2-MDP-A	PUMP	902050130	PUMP START NOT SATISFACTORY	TIME DELAY TESTED SATISFACTORY	790209	FS
2-MDP-A	PUMP	902131327	OIL COOLER END BELL CRACKED	REPAIRED COOLER	790324	FR
2-MDP-A	PUMP	901091437	REPACK INBOARD AND OUTBOARD GLANDS	REPACKED GLANDS	790324	BL
2-MDP-B	PUMP	809080610	HEAD BOLT LEAKS-NOS. 8, 12, 15, 16, 19	PERFORMED PREVENTATIVE MAINTENANCE	790430	BL
2-MDP-B	PUMP	901091438	REPACK INBOARD AND OUTBOARD GLANDS	VOID	790502	VOID
2-MDP-B	PUMP	805080342	CASING BOLTS 2, 3, 5 E SIDE 2 W SIDE	VOID	790511	VOID
2-MDP-A	INSTR	903061116	CHECK ON 6-1-79	RESET AND TESTED AGASTAT	790619	PMS
2-MDP-B	INSTR	903061115	CHECK ON 6-1-79	RESET AND TESTED AGASTATS	790621	PMS
1-MDP-A	PUMP	907030545	REPACK PUMP	REPACKED PUMP	790709	BL
1-MDP-B	PUMP	907030546	REPACK PUMP	REPACKED PUMP	790710	BL
1-MDP-B	PUMP	906030500	SEALS THROW WATER	ADJUSTED PACKING	790720	BL
2-MDP-A	PMP MTR	902111545	MOTOR HEATER NOT WORKING	INSTALLED NEW HEATERS - TESTED SAT	790910	FS
2-MDP-B	HX	901081400	REPAIR HEATERS	INSTALLED NEW HEATERS - TESTED SAT	790910	FS
1-MDP-B	PUMP	10162020	REBUILD SPARE ROTATING ELEMENT	VOID	791002	VOID
1-MDP-A	PUMP	910030700	OIL SUMP LEVEL INDICATOR IS BROKE	ADJUSTED FLOAT VALVE	791003	MD
1-MDP-A	PUMP	910212130	REPLACE PACKING	REPACKED INBOARD PACKING BOX	791021	BL
2-MDP-A	PUMP	910230640	REPACK PUMP	REPAIRED PUMP	791031	BL
2-MDP-B	PMP MTR	911042204	NO LEAK OFF THRUST BEARING & PACKING	ADJUSTED	791106	MD
1-MDP-B	INSTR	912071559	INSTALL NEW GAUGE	INSTALLED NEW GAUGE	791211	GAUGE
1-MDP-A	HX	912211400	TUBE LEAK	COMPLETED REPAIRS	791223	FR
2-MDP-A	INSTR	1040745	REPLACE OIL PRESS GAUGES	CHECKED CAL AND REPLACED GAUGES	800106	GAUGE
2-MDP-B	INSTR	1040746	REPLACE OIL PRESS GAUGES	CHECKED CAL AND REPLACED GAUGES	800106	GAUGE
2-MDP-A	PUMP	911050725	OUTBOARD PUMP PACKING BURNED UP	REPACKED	800128	MD
2-MDP-B	PUMP	1160213	REPLACE START SWITCH	TESTED SAT	800128	MD
1-MDP-B	PUMP	1301305	OIL PRESSURE GAUGE	GAUGE CHECKED SAT	800131	GAUGE
2-MDP-A	INSTR	2020715	SWITCH STICKS	SWITCH OPERATIONAL	800211	MD
1-MDP-A	PUMP	3011545	NO-LOAD AMPS	PI CURVE SAT	800318	PMS

\* PMS - PREVENTIVE MAINTENANCE    BL - BOUNDARY LEAK    VOID - VOIDED    MD - MINOR DEFICIENCY    GAUGE - GAUGE REPLACEMENT OR RECALIBRATION  
 DC - DESIGN CHANGE    FR- FAILURE TO RUN    FS - FAILURE TO START

Table B.1.b. (continued)

MARK NO.	COMPONENT	M. R. #	PROBLEM DESC	MODE/MECHANISM(if applicable) HISTORY SUMMARY	RTSVDT	CLASSIFICATION*
1-MDP-B	PUMP	3011546	NO-LOAD AMPS	PI CURVE SAT	800318	PMS
2-MDP-A	INSTR	4120800	GAUGE BROKEN	ADJUSTED GAUGE POINTER	800424	GAUGE
2-MDP-B	PUMP	912181500	SPLIT CASING IS LEAKING ON PUMP	VOID	800428	VOID
1-MDP-A	PUMP	5020510	OIL LEAK ON INBOARD	INSPECTED BEARINGS	800508	MD
2-MDP-A	PUMP	4180732	OUTBOARD PACKING LEAK	INSTALLED TEFLON PACKING	800603	BL
1-MDP-A	PUMP	5290447	VENTILATION SHIELD MISSING ON MOTOR	SHIELD REPLACED	800619	MD
2-MDP-A	VALVE	6181100	REPAIR HANDWHEEL AND STEM	REPLACED GASKET	800625	MD
1-MDP-B	PMP MTR	7151510	WRONG OIL IN REDUCTION GEAR	COMPLETED DRAINING AND REFILLED OIL	800717	MD
2-MDP-B	PUMP	7222155	PUMP WILL NOT AUTO START	TESTED SATISFACTORY	800725	FS
2-MDP-B	VALVE	4161555	NUT MISSING ON VALVE HANDWHEEL	INSTALLED NUT	800830	MD
2-MDP-B	INSTR	11010523	CALIBRATE	CAL GAUGES, REPLACED SUCTION GAUGE	801104	GAUGE
1-MDP-A	PUMP	12270930	DAMAGE WAS CAUSED BY FREEZING	FIXED SPLIT CASING	810101	FR
2-MDP-A	PUMP	101080715	SUCTION PRESSURE GAUGE MISSING	REPLACED MISSING GAUGE WITH CAL ONE	810109	GAUGE
1-MDP-A	HX	101130847	REPAIR BROKEN LUBE OIL COOLER	REPLACED GASKET AT HEAD	810114	FR
1-MDP-B	HT EXCH	101130846	HEAD-ON COOLER BROKEN	REMOVED HEAD, BRAZED TOGETHER	810114	FR
2-MDP-B	PUMP	101080714	LOW OIL LEVEL	OIL LEVEL NORMAL	810115	MD
1-MDP-A	PUMP	101291401	LUBE OIL COOLER BROKEN	REPAIRED LUBE OIL COOLER HEADER	810201	FR
1-MDP-A	PUMP	101291403	HEAT TRACE LUBE OIL COOLER	HEAT TRACING INSTALLED	810202	DC
1-MDP-A	PUMP	101291402	HEAT TRACE LUBE OIL COOLER	HEAT TRACING INSTALLED	810202	DC
1-MDP-B	PUMP	101291404	HEAT TRACE LUBE OIL COOLER	HEAT TRACING INSTALLED	810202	DC
1-MDP-A	HX	101311306	MANUFACTURE GASKET	REMOVED HEAD	810205	BL
1-MDP-A	PMP MTR	8271712	PERFORM PMS ON MOTOR	DISASSEMBLED AND REASSEMBLED MOTOR	810207	PMS
1-MDP-B	PMP MTR	102011220	UNCOUPLE PUMP FROM MOTOR	UNCOUPLED MOTOR FROM PUMP	810207	PMS
2-MDP-B	INSTR	102080500	REPLACE 2-MDP-B DISCHG PRESS GAUGE	REPLACED WITH NEW CALIBRATED GAUGE	810209	GAUGE
2-MDP-A	VALVE	102111630	INSPECT VALVE DISC	FURMANITED MANWAY	810212	BL
1-MDP-B	PUMP	102091230	PERFORM MMP-FW-004	PMS SERVICE WORK DONE	810214	PMS
1-MDP-A	PUMP	7110909	PERFORM PMS	VOID - DONE ON PREVIOUS MR	810217	VOID
1-MDP-B	PUMP	7110912	PERFORM PMS	VOID - DONE ON PREVIOUS MR	810217	VOID
1-MDP-B	PMP MTR	8271711	PERFORM PMS ON MOTOR	DISASSEMBLED AND ASSEMBLED MOTOR - SAT	810228	PMS
1-MDP-A	PUMP	103102255	PUMP WOULD DEVELOP NO DISCHARGE PRESS	VOID	810311	VOID
1-MDP-B	INSTR	103050933	REPLACE GAUGE DEFECTIVE ON TESTING	REPLACED GAUGE	810311	GAUGE
1-MDP-B	PMP MTR	12112345	UNCOUPLE MOTOR	UNCOUPLING MOTOR FROM PUMP	810312	PMS
1-MDP-B	PMP MTR	103121811	ALIGN AND COUPLE PUMP MOTOR	RECOUPLED PUMP TO MOTOR	810316	PMS
1-MDP-A	PMP MTR	102270714	REPAIR FLEX CONDUIT	MADE REPAIRS TO 1-MDP-A	810317	MD

\* PMS - PREVENTIVE MAINTENANCE    BL - BOUNDARY LEAK    VOID - VOIDED    MD - MINOR DEFICIENCY    GAUGE - GAUGE REPLACEMENT OR RECALIBRATION  
 DC - DESIGN CHANGE    FR- FAILURE TO RUN    FS - FAILURE TO START

Table B.1.b. (continued)

MARK NO.	COMPONENT	M. R. #	PROBLEM DESC	MODE/MECHANISM(if applicable) HISTORY SUMMARY	RTSVDT	CLASSIFICATION*
1-MDP-A	PUMP	8271030	REPAIR GAUGE	DISASSEMBLED GAUGE	810323	GAUGE
1-MDP-A	PUMP	102091231	PERFORM MMP-FW-004	PREVENTIVE MAINTENANCE SERVICE AND C	810328	PMS
1-MDP-B	PUMP	104011900	PACKING GLAND SPRAYING WATER	ADJUSTED PACKING	810403	BL
1-MDP-A	PUMP	104070800	PACKING LEAKS BOTH ENDS	ADJUSTED PACKING	810410	BL
2-MDP-A	VALVE	6160900	INSTALL CAP	REMOVED CHICAGO FITTING AND INSTALLED	810418	BL
1-MDP-B	INSTR	105030601	CHECK CALIBRATION	REPLACED GAUGE	810515	GAUGE
1-MDP-A	GAUGE	105120750	CALIBRATE GAUGE OR REPLACE	REPLACED GAUGE	810515	GAUGE
1-MDP-B	INSTR	105030600	CHECK CALIBRATION	REPLACED GAUGE	810515	GAUGE
1-MDP-A	GAUGE	105120751	CALIBRATE GAUGE OR REPLACE	REPLACED GAUGE	810515	GAUGE
1-MDP-A	INSTR	105220735	PUMP STARTED IN 62	RESET AGASTATS	810522	FS
1-MDP-B	INSTR	105220737	PUMP STARTED IN 66	RESET AGASTATS	810522	FS
2-MDP-A	INSTR	106020610	PRESSURE INDICATOR NEEDS REPLACING	INSTALLED NEW GAUGE	810602	GAUGE
1-MDP-A	PMP MTR	12112330	ALIGN AND COUPLE MOTOR TO PUMP	VOID - WORK COMPLETED PRIOR TO REC	810611	VOID
2-MDP-B	PUMP	4180731	NO OIL PRESSURE	PACKED STUDS CHECKED OIL PRESSURE	810616	FR
1-MDP-A	PUMP	107090729	RETUBE BYPASS LINES	COMPLETE	810925	PMS
1-MDP-B	PUMP	107090729	RETUBE BYPASS LINE	COMPLETE	810925	PMS
2-MDP-B	INSTR	110010720	CALIBRATE GAUGE	CALIBRATED GAUGE	811006	GAUGE
1-MDP-A	PUMP	812291330	OIL LEAK FROM INBOARD PUMP BEARING	VOID	811028	VOID
2-MDP-A	PUMP	111121500	BREAK COUPLING FOR ELECT	COMPLETED	811114	PMS
2-MDP-B	PUMP	111121502	UNCOUPLE COUPLING	COMPLETED	811114	PMS
2-MDP-A	MOTOR	111121503	RECONDITION MOTOR	VOID	811116	VOID
2-MDP-B	MOTOR	111121504	RECONDITION MOTOR	VOID	811116	VOID
2-MDP-A	MOTOR	112092200	MOTOR LEAKING OIL	FIXED OIL LEAK, SATISFACTORY	811210	MD
2-MDP-A	PUMP	112081530	COUPLE PUMP TO MOTOR	RECOUPLED PUMP	811211	PMS
2-MDP-B	PUMP	112081827	COUPLE 2-MDP-B	COUPLED	811211	PMS
2-MDP-A	PUMP	112211101	ALIGN PUMP AND MOTOR	ALIGNED COUPLING	811229	PMS
2-MDP-B	PUMP	112150596	OUTBOARD SHAFT SEAL ON PUMP LEAKS	REPLACED, UNCOUPLED	811229	BL
1-MDP-B	PUMP	112212300	REPACK 3B AFP	COMPLETED	820104	BL
2-MDP-A	PUMP	110091534	PERFORM MMP-P-FW-004	VOID	820105	VOID
2-MDP-B	PUMP	110091537	PERFORM MMP-P-FW-004	VOID	820105	VOID
2-MDP-A	PUMP	7110906	PERFORM PMS	VOID	820106	VOID
2-MDP-A	PUMP	111020615	INSTALL HEAT TRACING	INSTALLED HEAT TRACE, SATISFACTORY	820112	DC
2-MDP-B	PUMP	111020615	INSTALL HEAT TRACING	INSTALLED HEAT TRACE, SATISFACTORY	820112	DC
2-MDP-A	TC	112291236	REPLACE T/C ON 2-MDP-A	REPLACED THERMO READING, SATISFACTORY	820221	GAUGE

\* PMS - PREVENTIVE MAINTENANCE    BL - BOUNDARY LEAK    VOID - VOIDED    MD - MINOR DEFICIENCY    GAUGE - GAUGE REPLACEMENT OR RECALIBRATION  
 DC - DESIGN CHANGE    FR- FAILURE TO RUN    FS - FAILURE TO START

Table B.1.b. (continued)

MARK NO.	COMPONENT	M. R. #	PROBLEM DESC	MODE/MECHANISM(if applicable) HISTORY SUMMARY	RTSVDT	CLASSIFICATION*
2-MDP-A	MOTOR	203050957	BRIDGE MEGGER & RUN PI CURVE	BRIDGED & MEGGERED MOTOR	820305	PMS
2-MDP-B	MOTOR	203050956	BRIDGE MEGGER & RUN PI CURVE	BRIDGED & MEGGERED MOTOR	820305	PMS
1-MDP-B	PUMP	111110340	BEARING VIBRATION PUMP	REPLACED INBOARD BEARING	820309	FR
2-MDP-B	PUMP	202090532	NO GUARD ON COUPLING	INSTALLED COUPLING GUARD	820311	MD
2-MDP-B	PUMP	202090531	CASING LEAK	TIGHTENED BOLTING	820311	BL
1-MDP-A	MOTOR	203200519	MOTOR WAS SPRAYED WITH STEAM	PERFORMED PI CURVE	820320	FS
1-MDP-B	MOTOR	203110845	UNCOUPLE PUMP	VIBRATION RODS INDICATE MOTOR/DKP, SAT	820322	PMS
1-MDP-B	PUMP	203130335	EXCESSIVE VIBRATION PUMP	VOID - HOLDING PREVIOUS MR	820323	VOID
1-MDP-B	PUMP	203092235	INBOARD BEARING HAS HIGH VIBRATION	VOID	820324	VOID
1-MDP-A	PUMP	203261300	DETERMINE FAILURE OF PUMP	BREAKER CLOSED SATISFACTORY	820330	FS
1-MDP-B	PUMP	204110408	HIGH VIBRATION POINT 15.1B	OBSERVED IRD VIBRATION	820517	PMS
2-MDP-B	INSTR	206200426	OIL LEVEL GAUGE HAS BEEN REMOVED	NO REPAIR NEEDED	820628	VOID
2-MDP-A	MOTOR	206022605	FW-SV-E/A1	PERFORMED PMS	820703	PMS
1-MDP-A	MOTOR	206022599	FW-SV-E/A1	PERFORMED PMS	820704	PMS
2-MDP-A	PUMP	208020025	COVER MISSING - REPLACE	REPLACED COVER	820825	MD
2-MDP-A	PUMP	209011502	COUPLING GUARD MISSING, REPLACE	FOUND COUPLING GUARD	820913	MD
1-MDP-B	PUMP	209110240	BEARING ON PUMP IS LEAKING	TIGHTENED UP BOLTS AND	820920	MD
2-MDP-B	PMP MTR	210101905	BRIDGE MEGGAR PI CURVE MOTOR	PI CURVE SATISFACTORY	821010	PMS
1-MDP-A	GAUGE	210141054	REPLACE OIL PRESSURE GAUGES	REPLACED GAUGE WITH	821014	GAUGE
1-MDP-A	PUMP	210050528	FW LEAK UPSTREAM OF LUBE OIL COOLER	REPAIRED LEAK ON 3/4 PIPE	821014	FR
1-MDP-B	GAUGE	210141056	REPLACE OIL PRESSURE GAUGES	REPLACED GAUGE WITH	821014	GAUGE
1-MDP-A	INSTR	211102352	CALIBRATE BEARING OIL PRESSURE	INSTALLED NEW GAUGES	821112	GAUGE
2-MDP-A	INSTR	211102348	CALIBRATE BEARING OIL PRESSURE	INSTALLED NEW GAUGES	821112	GAUGE
1-MDP-B	PUMP	212071150	REPACK PUMP	ADDED PACKING	821207	BL
1-MDP-B	PUMP	212071930	PUMP NEEDS TO BE REPACKED	VOID - WORK DONE ON 1212071150	821208	VOID
2-MDP-B	VALVE	212070836	PACKING LEAK	INSTALLED 7 RINGS OF PACKING	821212	BL
2-MDP-B	VALVE	212070835	PACKING LEAK	ADJUSTED VALVE PACKING GLAND	821212	BL
2-MDP-A	GAUGE	212141458	INSTALL GAUGE	REPLACED MISSING	821216	GAUGE
1-MDP-A	PUMP	302102307	INBOARD PACKING NEEDS ADJUSTED	ADJUSTED PACKING	830216	BL
1-MDP-A	VALVE	302141430	VALVE EXTREMELY HARD TO CYCLE	VOID OPERATOR LUBRICATED THE VLV	830217	VOID
1-MDP-B	VALVE	302141431	VALVE EXTREMELY HARD TO CYCLE	VOID OPERATOR LUBRICATED THE VLV	830217	VOID
1-MDP-B	PUMP	304110429	INBOARD GLAND HAS EXCESSIVE LEAKAGE	ADJUSTED PACKING	830420	BL
1-MDP-A	PUMP	304011411	TEN YEAR HYDRO	INSPECTION COMPLETE	830428	PMS
1-MDP-B	PUMP	304011433	TEN YEAR HYDRO	INSPECTION COMPLETE	830428	PMS

\* PMS - PREVENTIVE MAINTENANCE    BL - BOUNDARY LEAK    VOID - VOIDED    MD - MINOR DEFICIENCY    GAUGE - GAUGE REPLACEMENT OR RECALIBRATION  
 DC - DESIGN CHANGE    FR- FAILURE TO RUN    FS - FAILURE TO START

Table B.1.b. (continued)

MARK NO.	COMPONENT	M. R. #	PROBLEM DESC	MODE/MECHANISM(if applicable) HISTORY SUMMARY	RTSVDT	CLASSIFICATION*
1-MDP-B	GAUGE	304271100	DISCH PRESS GAUGE NEEDS TO BE CALI	REPLACED GAUGE	830428	GAUGE
1-MDP-A	VALVE	305011737	VALVE COUPLING	REPLACED VARIOUS LEAKING FITTINGS	830511	BL
1-MDP-A	BOLT	302112151	1ST BOLT INBOARD ON TOP LEAKS	REPLACED GASKET AND	830525	BL
2-MDP-A	MOTOR	305060227	INSTALL WIRE MESH SCREENS ON MOTOR	INSTALLED SCREENS	830531	MD
2-MDP-B	MOTOR	305060230	INSTALL WIRE MESH SCREENS	INSTALLED SCREENS	830531	MD
1-MDP-A	BREAKER	306072125	RELAY DROP ON A PHSE INST	MOTOR BRIDGED + MEGGERED	830611	FS
1-MDP-B	PUMP	306110230	LUBE OIL LEAK ON OIL COOLER	TIGHTENED LUBE OIL	830621	MD
2-MDP-A	PUMP	304020343	REPLACE PLASTIC PLUGS ON MOTOR	NO PLUGS NEEDED	830710	VOID
2-MDP-B	PUMP	304020342	REPLACE PLASTIC PLUGS ON MTR	NO PLUGS NEEDED	830710	VOID
2-MDP-A	VALVE	307080532	PACKING LEAK	ADJUSTED PACKING GLAND	830724	BL
2-MDP-B	MOTOR	306021043	DISCONNECT AND RECONNECT	DISC + INSPECT BEARINGS	830730	PMS
2-MDP-A	PUMP	308091500	DAMPEN THE PULSATIONS TO GAUGE	INSTALLED VIBRATION DAMPENERS	830811	DC
2-MDP-A	PUMP	306080928	UNCOUPLE PUMP	ALIGNED AND COUPLED PUMP	830815	PMS
2-MDP-B	BREAKER	306241524	INSP ELEC INTERLOCKS	INSPECTED INTERLOCKS	830815	PMS
2-MDP-A	MOTOR	306021042	DISCONNECT + RECONNECT	DISASSEMBLE INSPECT REASSEMBLE	830822	PMS
2-MDP-B	PUMP	306080929	UNCOUPLE PUMP	RECOUPLED PUMP	830906	PMS
2-MDP-A	MOTO	309211500	REPAIR OR REPLACE MOTOR HEATER	REPLACED HEATER	831006	FS
2-MDP-A	RELAY	310060105	REPLACE 2-MDP-A RELAY	REPLACED RELAY COIL FAILED	831012	FS
1-MDP-A	GAUGE	310201508	LOCAL LEVEL GAUGE DOESN'T WORK	CLEANED UP LEVEL GAUGE	831027	MD
1-MDP-B	GAUGE	310201507	LUBE OIL RESERVOIR DOESN'T WORK	CLEANED UP LEVEL GAUGE	831027	MD
2-MDP-B	GAUGE	310201557	FIX OR REPLACE LUBE OIL GAUGE	CLEANED UP LEVEL GAUGE	831027	MD
1-MDP-B	PUMP	310221305	INBOARD SEAL LEAKS 1-MDP-B	ADJUSTED PACKING	831029	BL
2-MDP-A	PUMP	310300751	INSTALL COUPLING COVER	VOID - TO BE COMPLETED ON 0310280742	831101	VOID
2-MDP-A	GUARD	310280742	REINSTALL COUPLING GUARD	INSTALLED COUPLING GUARD	831102	MD
2-MDP-B	VALVE	311071146	PACKING LEAK	ADJUSTED PACKING GLAND	831111	BL
2-MDP-B	PUMP	309041254	INBRD + OUTBRD PMP SEALS LEAK	VOID	831202	VOID
2-MDP-B	GAUGE	311292204	CALIBRATE DISCHARGE PRESSURE GAUGE	CHECKED CALIBRATION OF GAUGE	831205	GAUGE
1-MDP-A	BOLT	312040340	CASING BOLT IS CRACKED	DETORQUED	831209	MD
1-MDP-A	VALVE	401040828	CLEAN AND GREASE VALVE STEM	CLEANED & LUBRICATED	840109	PMS
1-MDP-B	VALVE	401040832	CLEAN AND GREASE VALVE STEM	CLEANED & LUBRICATED	840109	PMS
2-MDP-A	VALVE	401040815	CLEAN AND GREASE VALVE STEM	CLEANED & LUBRICATED	840109	PMS
2-MDP-B	VALVE	401030818	CLEAN AND GREASE VALVE STEM	CLEANED & LUBRICATED	840109	PMS
1-MDP-A	MOTOR	304041600	DISCONNECT MOTOR	VOID-COMPLETED ON MR 1307012547	840118	VOID
1-MDP-A	PUMP	403030100	ADJUST PACKING	ADJUSTED PACKING GLAND	840303	BL

\* PMS - PREVENTIVE MAINTENANCE BL - BOUNDARY LEAK VOID - VOIDED MD - MINOR DEFICIENCY GAUGE - GAUGE REPLACEMENT OR RECALIBRATION  
 DC - DESIGN CHANGE FR- FAILURE TO RUN FS - FAILURE TO START

Table B.1.b. (continued)

MARK NO.	COMPONENT	M. R. #	PROBLEM DESC	MODE/MECHANISM(if applicable) HISTORY SUMMARY	RTSVDT CLASSIFICATION*
2-MDP-B	MOTOR	308310600	PLACE SIGHTGLASS ON OUTBRO MTR	VOID COMP ON MR2311161040	840403 VOID
2-MDP-B	PUMP	404011513	REPACK PACKING GLAND	REPACKED PUMP	840403 BL
1-MDP-A	VALVE	404141200	BODY TO BONNET LEAK	INSTALLED NEW SEAL RING	840417 BL
1-MDP-B	PUMP	405081516	INSPECT INSULATION AT MOTOR	ADDED INSULATION TO MOTOR LEADS FOR	840514 PMS
1-MDP-A	PUMP	405081515	INSPECT INSULATION AT MOTOR	INSPECTED LEADS TAPED FOR	840517 PMS
2-MDP-A	PUMP	405081536	INSPECT INSULATION AT MOTOR	INSPECTED MOTOR LEADS TAPED FOR	840517 PMS
2-MDP-B	PUMP	405081535	INSPECT INSULATION AT MOTOR	INSPECTED AND TAPED MOTOR LEADS	840517 PMS
1-MDP-B	PUMP	407161400	COUPLE BOLTS/NUTS CROSS THREADED	REPAIRED COUPLING GUARD AND	840727 MD
2-MDP-B	PUMP	311161040	REPLACE OUTBOARD BEARING SIGHT GLASS	CHECK FOR LEVEL GAUGE	840809 MD
2-MDP-A	PUMP	408010723	REPLACE BREAKER SPRING/COTTER PIN	VOID - COMPLETED ON WO 003088	840811 VOID
2-MDP-B	VALVE	312070509	BROKEN STEM	VOID - TO BE COMPLETED ON WO 001471	840817 VOID
1-MDP-A	PUMP	5707	UNCOUPLE AND RECOUPLE	VOID - WORK NOT TO BE PERFORMED THIS OUTAGE.	841113 VOID
1-MDP-B	PUMP	5706	UNCOUPLE/RECOUPLE	VOID - WORK NOT TO BE PERFORMED THIS OUTAGE.	841113 VOID
1-MDP-A	PUMP	10303	INBOARD PACKING LEAK 1-MDP-A	ADJUSTED INBOARD PACKING GLAND 1 FLAT ON GLAND NUTS.	841207 BL
1-MDP-A	PUMP	10304	ADJUST OUTBOARD PACKING LEAK	ADJUSTED OUTBOARD PACKING GALND 1 FLAT ON GLAND NUTS.	841207 BL
1-MDP-A	PUMP	10300	RESERVOIR INDICATOR CAP MISSING	NEED CAP IN ORDER TO FIX. CAPS ALL IN PLACE ON AUX FEED PUMPS.	850118 MD
2-MDP-B	PUMP	11952	ADJUST PACKING LEAK W/PMP RUNN	ADJUSTED PACKING	850107 BL
2-MDP-B	PUMP	02703	REPACK PUMP	VOID--NO PROBLEM EXISTS.	850301 VOID
2-MDP-A	PUMP	03088	PIN AND SPRING 25-14	VOID TO BE COMPLETED ON WO 12924	850306 VOID
1-MDP-A	PUMP	13467	REPAIR/REPLACE OIL SIGHT GLASS	REPLACE SIGHTGLASS TUBE 1/2-X2 LONG SIGHT GLASS USED FROM PIECE IN SPARE PARTS CAGE IN MACHINE SHOP.	850312 MD
2-MDP-A	PUMP	20053	INVEST/REPAIR PUMP 2-MDP-A	WORK PERFORMED BY AUTOMATION AND CONTROL. FOUND TRIP FUSES 25A5/25A6 PULLED CAUSING 2-MDP-A NOT TO AUTO START WHEN REQUIRED.	850517 NAF
2-MDP-B	PUMP	20076	2-MDP-B NO AUTO START	WORK PERFORMED BY AUTOMATION CONTROL/FOUND TRIP FUSES FOR 2585/2506 PULLED CAUSING 2-MDP-B NOT TO AUTO START WHEN REQUIRED 5/10/85.	850620 NAF
2-MDP-B	PUMP	15531	2-MDP-B CHECK HEATERS	REMOVED BAD HEATER FROM MOTOR -NO STOCK ITEM- HEATER ORDERED 3/25/85. REPLACED DEFECTIVE HEATER, TEST SAT.	850712 FS

\* PMS - PREVENTIVE MAINTENANCE    BL - BOUNDARY LEAK    VOID - VOIDED    MD - MINOR DEFICIENCY    GAUGE - GAUGE REPLACEMENT OR RECALIBRATION  
 DC - DESIGN CHANGE    FR- FAILURE TO RUN    FS - FAILURE TO START    NAF - NOT AN AGING FAILURE (MAINTENANCE ERROR)

B-18



Table B.1.b. (continued)

MARK NO.	COMPONENT	M. R. #	PROBLEM DESC	MODE/MECHANISM(if applicable) HISTORY SUMMARY	RTSVDT CLASSIFICATION*
2-MDP-A 1-MDP-A	PUMP PUMP	01077 13371	10 YR ISI HYDRO TEST AF PUMP REPAIR INBOARD/OUTBOARD LEAKAGE	VOID-WORK NOT REQUIRED RAN PUMP. NEEDED REPACKING. REMOVED PACKING INBD/ OUTBD ENDS. CLEAN/INSPECT GLAND STUDS NUTS WASHERS SHAFT SLEEVE CONDITION AS PER PROCEDURE. REPACKED WITH NEW PACKING WITH VOID - NOT REQUIRED.	850726 VOID 850731 BL
1-MDP-A 1-MDP-B	PUMP PUMP	6020 6019	1-MDP-A CHANGE BEARINGS 1-MDP-B DISCONNECT, INSPECT, RECONNECT	VOID - NOT REQUIRED. VOID - NOT REQUIRED.	850802 VOID 850802 VOID
1-MDP-B 1-MDP-B	PUMP PUMP	23128 23127	UNCLOG DRAIN LINE 1-MDP-B ADJUST PACKING/REMOVE EDCTR ON PUMP CSG	DISCONNECTED LINE AND BLEW OUT WITH AIR HOSE. ADJUSTED OUT BOARD END. REMOVED PIPING. CAPED 2 OPEN HOLES WITH 1/2 PIP CAPS 3/4 WRO SUBMITTED TO REPACK.	851015 MD 851106 BL
2-MDP-B	PUMP	27629	REPAIR EXCESS INBOARD VIBRATIONS	OPS RAN PUMP WITH DISCHARGE CLOSE AND RECEIVED HIGH VIBRATIONS ON INBOARD BEARING. SHIFT SUPERVISOR WANTED TO PULL COUPLING GUARD AND INSPECT COUPLING.	851210 NAF
2-MDP-B	PUMP	28864	ADJUST PACKING GLANDS	THE PACKING HAS A FREE FLOW LEAK-OFF, AN ADJUSTMENT TO A DRIP WILL CAUSE THE STUFFING BOX TO OVERHEAT LEFT AS IS.	860211 BL
1-MDP-B	PUMP	26260	REPACK PUMP	LEAK MECHANISM/WORN PACKING REMOVED OLD PACKING, INSTALLED NEW 1/2 - GARLOCK PACKING. ADJUSTED WITH PIMP RUNNING SAT.	860409 BL
2-MDP-A 2-MDP-A	PUMP PUMP	28853 26971	ADJUST PACKING GLANDS REPLACE PKG BLND BOLTS	VOID COMPLETED ON WO 26971. CLEANED OUT CATCH BASIN, DISCONNECTED LINES, CLEANED DIRT FROM THEM AND RECONNECTED. DRAIN CLOGGED/DIRT	860423 VOID 860502 MD
2-MDP-A 2-MDP-B	PUMP PUMP	34892 34891	2-MDP-A ADD OIL 2-MDP-B ADD OIL	OIL ADDED 5/6/86 OUTBOARD BEARING AMER. IND 58 OIL OIL ADDED IN OUTBOARD BEARING 5/6/86 AMERICAN IND 58 OIL.	860510 MD 860510 MD
1-MDP-B	PUMP	26973	P-REPACK PUMP	REPACKED PUMP AGIAN AFTER PREVIOUS PACKING HAD BEEN SMOKED . PASSED PT.	860611 BL
1-MDP-A	PUMP	37002	1-MDP-A EWR 86-174	REMOVED TAPE AND FOUND CABLE A WAS BRAKING. WE REPLACED THE LUG AND RAYCHEM ALL THREE OF THE LEADS WITH NM CK-72.	860620 PMS

B-19

\* PMS - PREVENTIVE MAINTENANCE    BL - BOUNDARY LEAK    VOID - VOIDED    MD - MINOR DEFICIENCY    GAUGE - GAUGE REPLACEMENT OR RECALIBRATION  
DC - DESIGN CHANGE    FR- FAILURE TO RUN    FS - FAILURE TO START    NAF - NOT AN AGING FAILURE (MAINTENANCE ERROR)

Table B.1.b. (continued)

MARK NO.	COMPONENT	M. R. #	PROBLEM DESC	MODE/MECHANISM(if applicable) HISTORY SUMMARY	RTSVDT CLASSIFICATION*
1-MDP-B	PUMP	37003	1-MDP-B EWR 86-174	REMOVED ALL TAPE AND CLEANED THE CABLE WITH A-2 CABLE PREPARATION KIT THEN REPLACED THE TAPE WITH RAYCHEM SPLICE KIT NM CK-IL.	860620 MD
1-MDP-A	PUMP	26972	P-REPLACE GLAND BOLTS/REPACK	BAD THREADS/NORMAL WEAR DO NOT NEED TO REPLACE AND SAVE STUDS AND NUTS FOR ENGINEERING AS PER TEL CONVERSATION. UNCLOGGED DRAIN.	860708 MD
1-MDP-A	PUMP	36782	IMPLEMENT EWR 85-544	REMOVE LINE FAILURE/UNNEEDED REMOVE PIPE SUPPORT AS PER EWR FLUSH AND SUBMIT SERVICE REQUEST TO REPAINT.	860710 PMS
1-MDP-B	PUMP	34951	1-MDP-B REPAIR CONDUIT	CONDUIT BROKEN/ABUSE - SAT ON REPAIRED CONDUIT CHECKED RESISTANCE ON RTD, OK.	860710 MD
1-MDP-B	PUMP	36783	PERFORM EWR 85-544	REMOVE LINE FAILURE/UNNEEDED REMOVE PIPE SUPPORT AND GRIND FLUSH AS PER EWR. SUBMIT SERVICE TO PAINT SURFACES.	860710 MD
1-MDP-B	PUMP	38277	REPACK PUMP	LEAKING PKG FAILURE/BURNED PACKING REMOVED 6 RINGS OLD PACKING, REPLACED WITH 6 RINGS 1/2 - GARLOCK, TEST RUN PMP PT SAT.	860711 BL
1-MDP-A	PUMP	35286	UNPLUG THE PUMP BASE	CLEANED DRAIN LINES ON PUMP WITH A ROD.	860804 MD
1-MDP-A	PUMP	39854	1-MDP-A MOTOR WET	PERFORM PI CURVE ON MOTOR WINDINGS, TESTED SATISFACTORY.	860826 FS
1-MDP-B	PUMP	39853	1-MDP-B MOTOR WET	PERFORMED PI CURVE ON MOTOR WINDING.	860826 FS
1-MDP-A	PUMP	35287	ADJUST/REPACK PUMP	VOID - COMPLETED ON WO 026972.	860828 VOID
2-MDP-A	PUMP	38610	REFURBISH ROTATING ASSY.	ROTOR ASSY HAS BEEN REFURBISHED AND IS LOCATED	861001 PMS
1-MDP-B	PUMP	42940	REPAIR BEARING/LEAKOFF LINE	REMOVED OLD PACKING - 8 RINGS - AND INSTALLED GARLOCK 98 - 7 RINGS-. INSTALLED GLAND NUTS FINGER TIGHT - SLIGHTLY SNUGGED-. TSTS RAN PUMP. ADJUSTED PACKING GLAND SAT. LEAK OFF	861011 BL
2-MDP-A	PUMP	45005	2-MDP-A RAYCHEM CABLE LEADS	VOID RAYCHEM NOT NEEDED, ENG. HAS ACCEPTED TAPE-UP.	861110 VOID

\* PMS - PREVENTIVE MAINTENANCE    BL - BOUNDARY LEAK    VOID - VOIDED  
 DC - DESIGN CHANGE    FR- FAILURE TO RUN    FS - FAILURE TO START    MD - MINOR DEFICIENCY    GAUGE - GAUGE REPLACEMENT OR RECALIBRATION

Table B.1.b. (continued)

MARK NO.	COMPONENT	M. R. #	PROBLEM DESC	MODE/MECHANISM(if applicable) HISTORY SUMMARY	RTSVOT CLASSIFICATION*
1-MDP-A	PUMP	46435	CALIBRATE/REPLACE GAUGE	WEAR/ REPLACED GAUGE WITH NEW 0-60# GAUGE.	861216 GAUGE
1-MDP-B	PUMP	46436	CALIBRATE/REPLACE GAUGE	WEAR/VIBRATION REPLACED GAUGE WITH NEW 0-60# GAUGE.	861216 GAUGE
1-MDP-A	PUMP	45559	CLEAN DRAIN LINE	LINE PLUGGED/FOREIGN MATTER IN LINE CLEANED DRAIN LINE BY INSERTING WIRE INTO LINE. LINE FLOWED FREELY WATCHED IT FOR 10 MINUTES.	861218 MD
1-MDP-B	PUMP	35597	P-UNCLOG DRN/REPK/REPL STUDS	UNCLOG DRAIN PIPE. REPACKED PUMP. REPLACED GLAND STUDS RAN PUMP ADJUSTED PACKING.	870108 BL
1-MDP-B	PUMP	47744	REMOVE/INSTALL OLD-DOWN BOLTS	REMOVED MOTOR HOLD DOWN BOLTS ONE AT A TIME. CLEANED FEL-PRO REINSTALLED MOTOR HOLD DOWN BOLTS. TORQUED TO 110 FT.LBS. WORKED WITH WORN/BEARINGS	870116 MD
1-MDP-B	PUMP	49510	1-MDP-B INSPECT BEARINGS	REMOVED OUTBOARD BEARING FOR INSPECTION/FOUND READING OUT OF TOLERANCE BY APPROX .01. AMER. IND #68 REASSEMBLED MOTOR. TOOK ALIGNED PUMP TIR .0025 RECOUPLED.	870212 PMS
1-MDP-B	PUMP	48408	UNCOUPLE/RECOUPLE PUMP	VOID ORDERED PARTS ARRIVED IN TIME NOT TO HAVE TO USE UNIT 2 PARTS.	870214 VOID
2-MDP-B	PUMP	43431	REMOVE AND REPLACE COUPLING PART	VIBRATION/EXCESS VIBRATION AND WEAR. FOUND THE PUMP UNCOUPLED AND THE BEARING HOUSING COVER AND HOUSING TOP'S REMOVED. REMOVED THE STUFFING BOX EXTENSIONS.	870303 PMS
2-MDP-A	PUMP	50038	OVERHAUL PUMP	PUMP WAS OVERHAULED AND MOTOR ALIGNED AND RECOUPLED ON WO 52038 3/3/87, UNCOUPLED 2/2/87. VOID TO 52038.	870304 PMS
2-MDP-A	PUMP	49133	UNCOUPLE PMP MOTOR	CHANGED OIL IN CENTRAL LUBE SYSTEMS ON 2-MDP-B MOTOR DRIVEN AUX FEED PUMP. FLUSHED SYSTEM WITH CLEAN OIL AND REFILLED TO OIL LEVEL.	870309 VOID
2-MDP-A	PUMP	49122	ENG EVAL HIGH VIPES PT-15.1A		870309 PMS
2-MDP-B	PUMP	50003	CHANGE OIL IN CENTRAL LUBE SYSTEM	LEAKING/ADJUSTMENT ADJUSTED PACKING. OUTBOARD PACKING NEEDS TO BE REPACKED.	870314 BL
2-MDP-A	PUMP	50816	ADJUST PACKING	VOID RECENT OIL ANALYSIS REVEALS APPARENT COOLER LEAKAGE	870317 VOID
2-MDP-B	PUMP	50637	REPLACE LUBE OIL COOLER		

\* PMS - PREVENTIVE MAINTENANCE    BL - BOUNDARY LEAK    VOID - VOIDED  
 DC - DESIGN CHANGE    FR- FAILURE TO RUN    FS - FAILURE TO START    MD - MINOR DEFICIENCY    GAUGE - GAUGE REPLACEMENT OR RECALIBRATION

Table B.1.b. (continued)

MARK NO.	COMPONENT	M. R. #	PROBLEM DESC	MODE/MECHANISM(if applicable) HISTORY SUMMARY	RTSVDT CLASSIFICATION*
1-MDP-A	PUMP	50699	1-MDP-A ADD OIL AS NEEDED	ADDED OIL TO INBOARD AND OUTBOARD BEARING, ABOUT 1/2 PINT IN EACH (3/16/87).	870319 PMS
2-MDP-A	PUMP	51215	2-MDP-A REMOVE/REPLACE H. T.	REPLACED HEAT TAPE THAT HAD BEEN REMOVED. CHECKED CHECKED AMPS TO SEE IF TAPE WORKED. 3.0 AMPS.	870323 MD
2-MDP-B	PUMP	50289	ADD OIL TO BEARINGS	VOID NO WORK PERFORMED OIL LEVELS ARE SAT.	870324 VOID
2-MDP-A	PUMP	51214	REPLACE/REPAIR LUBE OIL COOLER	LEAK/OIL IN WATER/WATER IN OIL. REMOVED LUBE OIL COOLER AND HYDRO WITH 100 PSI SERVICE AIR. NO LEAKAGE EVIDENT.	870331 FR
2-MDP-A	PUMP	51233	CHANGE OIL	REMOVED OLD OIL FROM PUMP AND FLUSHED PUMP WITH NEW OIL. AFTER FLUSHING THE PUMP, THEN REFILLED WITH NON PAREIL TURBINE OIL MEDIUM AS REQUESTED.	870403 PMS
2-MDP-A	PUMP	51852	FLUSH OIL SYSTEM	WATER IN OIL/UNKNOWN. DRAIN WATER AND OIL FROM INBOARD BEARING HOUSING. DRAIN WATER AND OIL FROM OUTBOARD ENDBEARING HOUSING ADDED APPROX 1 GAL.	870403 PMS
2-MDP-A	PUMP	51834	REPACK INBOARD END	PACKING BURNT/TOO TIGHT. REMOVED OLD PACKING AND FOUND THAT IT HAD BEEN BURNT. REPLACED PUMP WITH 7 RINGS OF 1/2-GARLOCK 98. HAD OPS RUN PUMP.	870403 MD
1-MDP-A	PUMP	51995	1-MDP-A MOTOR OIL FLOW	ADDED OIL TO INBOARD AND OUTBOARD MOTOR BEARINGS. CHECKED FOR OIL LEAKS.	870410 MD
2-MDP-B	PUMP	52246	2-MDP-B REPLACE OIL RESERVOI	REPLACED SIGHT GLASSES. REPLACED OIL. TEST RAN SAT 4/14/87	870414 MD
2-MDP-A	PUMP	51085	-P-REPACK OUTBOARD PACKING GLAND	VOID TO 51384.	870414 VOID
2-MDP-B	PUMP	50818	ADJUST PACKING	AS FOUND PACKING LEAKING IN STREAM APPROX. THE SIZE OF PENCIL LEAD. PRE-OILED BOTH BEARINGS TIGHTENED PACKING GLAND NUTS ONE HALF OF ONE FLAT TO DECREASE LEAKAGE TO BROKEN	870416 BL
2-MDP-B	PUMP	51500	2-MDP-B REPLACE SIGHT GLASS	VOID COMPLETED ON WO#380002275	870421 VOID
1-MDP-B	PUMP	49509	P-REPLACE MOTOR HEATERS	HEATERS BAD/AGE, REPLACED HTRS MEGGERED 14 MEGOHMS AMPS .8 1.1 WORKED SAT. CHANGED OVERLOADS INSTALLED 1018L.	870522 FS
2-MDP-B	PUMP	53202	2-MDP-B ADD OIL TO MOTOR	LOW LEVEL/UNKNOWN ADDED OIL TO OUTBOARD BRG. 7 OZ INBOARD WAS SAT.	870522 MD

\* PMS - PREVENTIVE MAINTENANCE    BL - BOUNDARY LEAK    VOID - VOIDED  
 DC - DESIGN CHANGE    FR- FAILURE TO RUN    FS - FAILURE TO START    MD - MINOR DEFICIENCY    GAUGE - GAUGE REPLACEMENT OR RECALIBRATION

Table B.1.b. (continued)

MARK NO.	COMPONENT	M. R. #	PROBLEM DESC	MODE/MECHANISM(if applicable) HISTORY SUMMARY	RTSVDT CLASSIFICATION*
2-MDP-B	PUMP	49544	ENGINEERING EVALUATION	VOID PUMP TESTED SAT ON 3-11-87, 4-8-87, AND 5-8-87.	870529 VOID
1-MDP-A	PUMP	54236	1-MDP-A CLEANED SIGHT GLASS	NO ACTUAL FAILURE INVOLVED. CLEANED PAINT OFF OF SIGHT GLASS FOR SLING RING AND THE ONE FOR OIL LEVEL ON THE INBOARD END OF MOTOR.	870625 MD
1-MDP-A	PUMP	54772	1-MDP-A ADD OIL TO MOTOR	ADDED INDUSTRIAL 68 OIL TO INBOARD AND OUTBOARD BEARINGS TO PROPER LEVELS. NO LEAKS.	870714 MD
2-MDP-B	PUMP	54745	2-MDP-B ADD OIL TO MOTOR	ADDED OIL TO INBOARD AND OUTBOARD MOTOR BEARINGS. DID NOT SEE ANY OIL LEAKS OUTSIDE OF MOTOR.	870714 MD
1-MDP-A	PUMP	54736	INVESTIGATE/REPAIR	INDUSTRIAL 68 OIL. WORN OUT/OLD AGE	870724 GAUGE
2-MDP-A	PUMP	54737	CAL/REPLACE GAUGE	REPLACED GAGE WITH NEW GAGE FROM ATTACHED MATERIAL REQUISITION. NEW GAGE WAS TESTED OK. WORN OUT/OLD AGE.	870725 GAUGE
2-MDP-B	PUMP	52414	-P- REPLACE LO COOLER	REPLACED GAGE WITH NEW GAGE FROM ATTACHED COPY OF MATERIAL REQUISITION NEW GAGE WAS TESTED OK. LEAKING OIL/ INSTALL NEW COOLER. AS FOUND- COOLER LEAKING. WORK PERFORMED-INSTALLED NEW OIL COOLER. AS LEFT-TEST SAT.	870807 FR
2-MDP-B	PUMP	54267	CHANGE OIL FLUSH LINES AS REQD	AS FOUND- OIL CLEAN. NO FOREIGN OBJECTS IN OIL RESERVOIR, NO BEARING MATERIAL PRESENT IN RESERVOIR OR FILTER. WORK BONE- DRAINED OIL FROM VOID TO 053124	870807 PMS
2-MDP-B	PUMP	52248	2-MDP-B REPLACE SIGHT GLASS	ADDED AMER INDUSTRIAL #58. ADDED ABOUT 5 OZ AND LEVEL CAME UP A LITTLE ABOVE THE HALF WAY MARK.	870811 VOID
2-MDP-A	PUMP	55679	2-MDP-A ADD OIL	NO ADJUSTMENT REQUIRED. PROPER LEAK OFF.	870819 MD
1-MDP-A	PUMP	48997	ADJUST PACKING GLANDS	REMOVED PLUG AND INSTALLED BULL'S EYE SIGHT GLASS 9/11/87	870903 BL
2-MDP-B	PUMP	53124	2-MDP-B INSTALL SIGHTGLASS	CHECKED SIGHT GLASS OIL LEVEL. FOUND OIL LEVEL TO BE A LITTLE LOW ADDED OIL TO 1-MDP-A INBOARD MOTOR BEARING. ADDED AMERICAN INDUSTRIAL	870916 MD
1-MDP-B	PUMP	56885	P-REPLACE MOTOR BEARING OIL		870929 MD

\* PMS - PREVENTIVE MAINTENANCE    BL - BOUNDARY LEAK    VOID - VOIDED    MD - MINOR DEFICIENCY    GAUGE - GAUGE REPLACEMENT OR CALIBRATION  
 DC - DESIGN CHANGE    FR- FAILURE TO RUN    FS - IYNCIPIENT FAILURE TO START

Table B.1.c. MAINTENANCE RECORDS FOR THE AUXILIARY FEEDWATER SYSTEM 3-INCH MOTOR OPERATED VALVES

MARK NO.	COMPONENT	M. R. #	PROBLEM DESC	MODE/MECHANISM(if applicable) HISTORY SUMMARY	RTSVDT CLASSIFICATION*
2-MOV-A	MOV	803201901	PACKING LEAK	REPACKED VALVE	780330 BL
2-MOV-D	MOV	804061950	WON'T STAY CLOSED	ADJUSTED SWITCH	780407 PG
1-MOV-B	MOV	805011126	CLEAN AND INSPECT	DISCONNECTED/RECONNECTED AND TESTED	780527 PMS
1-MOV-C	MOV	805011125	CLEAN AND INSPECT	DISCONNECTED/RECONNECTED AND TESTED	780527 PMS
1-MOV-E	MOV	805011123	CLEAN AND INSPECT	DISCONNECT/RECONNECTED AND TESTED	780527 PMS
1-MOV-D	MOV	805011124	CLEAN AND INSPECT	CLEANED, INSPECTED AND TESTED	780602 PMS
1-MOV-F	MOV	805011122	CLEAN AND INSPECT	CLEANED, INSPECTED AND TESTED	780602 PMS
1-MOV-B	MOV	10185580	LEAKS BY SEAT	CUT DISC - LAPPED SEAT	780604 SL
1-MOV-C	MOV	806010833	INSPECT SEAT FOR CRACKS	INSPECTED SEAT	780604 PMS
1-MOV-C	MOV	10185570	LEAKS BY SEAT	CUT DISC - LAPPED SEAT	780604 SL
1-MOV-D	MOV	10185560	LEAKS BY SEAT	INSPECTED AND REASSEMBLED VALVE	780604 PMS
1-MOV-E	MOV	806010831	INSPECT SEAT FOR CRACKS	INSPECTED SEAT	780604 PMS
1-MOV-E	MOV	10185550	LEAKS BY SEAT	CUT DISC - LAPPED SEAT	780604 SL
1-MOV-F	MOV	10185540	LEAKS BY SEAT	INSPECTED VALVE AND REASSEMBLED	780604 PMS
1-MOV-F	MOV	806022200	TORQUE SWITCH BAD	REPLACED TORQUE SWITCH	780605 PG
1-MOV-C	MOV	806131540	DISCONNECT/RECONNECT FOR MECHANICS	VOID	780616 VOID
1-MOV-E	MOV	806131542	DISCONNECT/RECONNECT FOR MECHANICS	DISCONNECTED/RECONNECTED - SET LIMITS	780616 PMS
1-MOV-F	MOV	806131543	DISCONNECT/RECONNECT FOR MECHANICS	VOID	780616 VOID
1-MOV-A	MOV	805011127	CLEAN AND INSPECT	CLEANED AND INSPECTED	780627 PMS
1-MOV-A	MOV	806131538	DISCONNECT/RECONNECT FOR MECHANICS	RECONNECTED AND TESTED SATISFACTORY	780627 PMS
1-MOV-A	MOV	10185590	LEAKS BY SEAT	REPLACED SEAT	780629 SL
1-MOV-B	MOV	806010832	INSPECT SEAT FOR CRACKS	CHECK VALVE FOR SEATING	780629 PMS
1-MOV-D	MOV	806041005	REPAIR OR REPLACE CRACKED SEATS	REPLACED SEAT RING	780629 SL
1-MOV-F	MOV	806041006	REPAIR OR REPLACE CRACKED SEAT	REPLACED SEAT RING	780629 SL
1-MOV-B	MOV	806302330	BREAKER WILL NOT RESET AND VALVE	REPAIRED - TESTED SATISFACTORY	780706 PG
1-MOV-D	MOV	806131541	DISCONNECT/RECONNECT FOR MECHANICS	DISCONNECTED/RECONNECTED - TEST SAT	780710 PMS
1-MOV-B	MOV	806131539	DISCONNECT/RECONNECT FOR MECHANICS	VOID	780814 VOID
1-MOV-F	MOV	809162130	VALVE LEAKS THRU-CHECK LIMITS	CHECKED LIMITS - SATISFACTORY	780918 PMS
2-MOV-A	MOV	810110135	DID NOT AUTO OPEN	CHECKED OUT CONTROL CIRCUIT - OK	781015 PG
1-MOV-C	VALVE	812140713	1-MOV-C HAS PACKING LEAK	INSTALLED NEW PACKING	781222 BL
1-MOV-E	VALVE	812141007	PACKING LEAKS	INSTALLED NEW PACKING	781222 BL
1-MOV-F	VALVE	812141008	PACKING LEAKS	INSTALLED NEW PACKING	781222 BL
1-MOV-E	MOV	906071201	REPLACE JAMMED BOLT ON FLANGE	REPAIRED BOLT	790611 MD
1-MOV-F	MOV	906071200	PACKING LEAK	TIGHTENED PACKING GLAND	790611 BL

\* PMS - PREVENTIVE MAINTENANCE BL - BOUNDARY LEAK VOID - VOIDED MD - MINOR DEFICIENCY SL - SEAT LEAKAGE  
 DC - DESIGN CHANGE PG - PLUGGING FAILURE SWITCH - NON-FUNCTIONAL FAILURE OF LIMIT SWITCH

Table B.1.c. (continued)

MARK NO.	COMPONENT	M. R. #	PROBLEM DESC	MODE/MECHANISM(if applicable) HISTORY SUMMARY	RTSVDT	CLASSIFICATION*
1-MOV-A	MOV	907031530	REPLACE HANDWHEEL	REPLACED HANDWHEEL	790808	MD
1-MOV-D	MOV	909171517	PACKING LEAK	ADJUSTED PACKING	790919	BL
1-MOV-A	MOV	10142910	PERFORM PROCEDURE EMP-P-MOV-45	VOID	791023	VOID
2-MOV-D	MOV	901251409	MOV PMS	COMPLETED AS PER EMP-P-MOV-45	791106	PMS
2-MOV-D	MOV	911081020	SEVERE PACKING LEAK	REPACKED VALVE	791110	BL
2-MOV-D	MOV	911081355	LIMIT SWITCH NEEDS ADJUSTMENT	VOID	791217	VOID
1-MOV-E	MOV	1061910	MOTOR HOUSING SHATTERED	REPLACED WITH LIMTORQUE FROM MOV 251	800107	PG
1-MOV-A	MOV	1041823	VALVE LEAKS BY	A TORQUE SWITCH	800119	SWITCH
1-MOV-B	MOV	1041830	VALVE LEAKS BY	ADJUSTED TORQUE SWITCH	800119	SWITCH
1-MOV-C	MOV	1041842	VALVE LEAKS BY	ADJUSTED TORQUE SWITCH	800119	SWITCH
1-MOV-D	MOV	1041845	VALVE LEAKS BY	ADJUSTED TORQUE LIMITS	800119	SWITCH
1-MOV-E	MOV	1041825	LEAKS BY SEAT CHECK LIMITS	ADJUSTED TORQUE LIMITS	800119	SWITCH
1-MOV-F	MOV	1041826	LEAK BY SEAT CHECK LIMITS	ADJUSTED TORQUE LIMITS	800119	SWITCH
2-MOV-F	MOV	1210100	DISCONNECT+RECONNECT FOR MECH	VOID	800124	VOID
2-MOV-F	MOV	1181431	REMOVE STEM NUT FOR MEASUREMENT	COMPLETED	800124	PMS
1-MOV-E	MOV	1061825	DISCONNECT AND RECONNECT POWER	MOV REPLACED ON UNIT 1	800219	PG
2-MOV-A	MOV	3050930	REPACK 2-MOV-A	REPACKED VALVE	800307	BL
2-MOV-B	MOV	3050931	REPACK 2-MOV-B	REPACKED VALVE	800307	BL
2-MOV-C	MOV	3050932	REPACK 2-MOV-C	REPACKED VALVE	800307	BL
2-MOV-D	MOV	3050933	REPACK 2-MOV-D	REPACKED VALVE	800307	BL
2-MOV-E	MOV	3050934	REPACK 2-MOV-E	REPACKED VALVE	800307	BL
2-MOV-F	MOV	3050935	REPACK 2-MOV-F	REPACKED VALVE	800307	BL
2-MOV-E	MOV	1062046	REMOVE MOV FOR USE ON UNIT 1	COMPLETED	800323	PG
2-MOV-E	MOV	901251410	MOV PMS	PERFORMED PMS ON MOV	800325	PMS
2-MOV-E	MOV	1062045	DISCONNECT MOV FOR MECHANICS	RECONNECTED AND TESTED MOV	800325	PMS
2-MOV-B	MOV	901251407	MOV PMS	TESTED SATISFACTORY	800410	PMS
2-MOV-C	MOV	901251408	MOV PMS	TESTED SATISFACTORY	800410	PMS
2-MOV-A	MOV	901251406	MOV PMS	COMPLETED	800411	PMS
2-MOV-A	MOV	4090913	MOV LEAKS BY	REPACKED VALVE	800509	BL
2-MOV-B	MOV	4090914	MOV LEAKS BY	REPACKED VALVE	800509	BL
2-MOV-C	MOV	4090915	MOV LEAKS BY	REPACKED VALVE	800509	BL
2-MOV-E	MOV	4090917	MOV LEAKS BY	REPACKED VALVE	800509	BL
2-MOV-F	VALVE	4291230	DISASSEMBLE LIMITORQUE FOR INSPECTION	UNSTUCK	800509	PG
2-MOV-F	MOV	4090918	MOV LEAKS BY	REPACKED VALVE	800509	BL

\* PMS - PREVENTIVE MAINTENANCE    BL - BOUNDARY LEAK    VOID - VOIDED    MD - MINOR DEFICIENCY    SL - SEAT LEAKAGE  
 DC - DESIGN CHANGE    PG - PLUGGING FAILURE    SWITCH - NON-FUNCTIONAL FAILURE OF LIMIT SWITCH

Table B.1.c. (continued)

MARK NO.	COMPONENT	M. R. #	PROBLEM DESC	MODE/MECHANISM(if applicable) HISTORY SUMMARY	RTSVDT	CLASSIFICATION*
2-MOV-D	VALVE	4211429	VALVE OPEN WHEN SHOULD BE SHUT	VALVE OPERATES AS DESIGNED	800513	PG
2-MOV-A	VALVE	4280457	HANDWHEEL MISSING	VOID	800521	VOID
2-MOV-B	VALVE	4280456	HANDWHEEL MISSING	VOID	800521	VOID
2-MOV-D	MOV	5281601	MOV IS SHUT BREAKER IS OPEN	ADJUSTED SWITCH	800602	PG
2-MOV-F	MOV	901251411	MOV PMS	COMPLETED AS PER ABOVE PROCEDURES	800604	PMS
2-MOV-B	MOV	7160826	PACKING LEAK	CLEANED VALVE STEM	800717	BL
2-MOV-A	MOV	7161130	PACKING LEAK	REPAIRED LEAK	800718	BL
2-MOV-D	MOV	4090916	MOV LEAKS BY	VOID	800724	VOID
2-MOV-B	MOV	8230940	TORQUE SWITCH PROBLEM	REPAIRED BROKEN WIRE	800826	PG
2-MOV-B	MOV	11011730	MOV WILL NOT OPERATE	REPAIRED LEADS, TEST SWITCH SATISFACTORY	801104	PG
2-MOV-B	MOV	8230615	VALVE WILL NOT OPEN	VOID - MRS2011011730	810107	VOID
1-MOV-B	MOV	905180840	LEAKS THROUGH	COMPLETED	810112	SL
1-MOV-B	MOV	11191101	DISCONNECT AND RECONNECT FOR MECHANICS	COMPLETED AS PER EMP-C-MOV-11	810222	PMS
1-MOV-B	MOV	9070120	PERFORM PMS	PMS COMPLETED	810222	PMS
1-MOV-D	MOV	9070118	PERFORM PMS	PMS COMPLETED	810222	PMS
1-MOV-D	MOV	11191102	DISCONNECT AND RECONNECT FOR MECH	COMPLETED AS PER EMP-C-MOV-11	810222	PMS
1-MOV-F	MOV	11191103	DISCONNECT AND RECONNECT FOR MECHANICS	DISCONNECT AND RECONNECT	810308	PMS
1-MOV-F	MOV	9070116	PERFORM PMS	PERFORMED AS PER PMS	810308	PMS
1-MOV-C	MOV	9070119	PERFORM PMS	PERFORMED PMS ON VALVE	810311	PMS
1-MOV-E	MOV	9070117	PERFORM PMS	PERFORMED PMS ON VALVE	810311	PMS
1-MOV-C	VALVE	10323747	REPACK VALVE	REPACKED VALVE	810324	BL
1-MOV-E	VALVE	103230748	REPACK VALVE	REPACKED VALVE	810324	BL
1-MOV-F	MOV	906180842	LEAKS THRU	NEEDED TO BE WIRED UP	810325	PG
2-MOV-A	VALVE	104221730	REPACK, ADJUST PACKING	COMPLETED	810425	BL
1-MOV-D	VALVE	104300145	ADJUST LIMITS	COMPLETED AS PER EMP-C-MOV-63	810531	SWITCH
1-MOV-A	MOV	8081510	REPAIR LIMIT SWITCH	VOID - PERFORMED ON ANOTHER MR	810601	VOID
1-MOV-A	MOV	103131730	DISCONNECT/RECONNECT FOR MECHANICS	ADJUSTED LIMITS AS PER PROCEDURE	810604	PMS
1-MOV-A	MOV	9070121	PERFORM PMS	COMPLETED AS PER PMS PROCEDURE	810604	PMS
1-MOV-E	MOV	106100420	CHECK CONTROL CIRCUIT FOR POSS GROUND	COMPLETED AS PER EMP-C-MOV-63	810611	PG
1-MOV-B	MOV	101201701	CONT AND PWR CABLES DETERM FROM OPER	VOID - WORK PERFORMED ON ANOTHER MR	810612	VOID
1-MOV-A	MOV	103110840	VALVE STIFF	COMPLETED	810618	PG
1-MOV-D	MOV	9241901	GROUND AND REPAIR WELDS	VOID - INSPECTION SHOWS NO WELD REPAIR	810624	VOID
1-MOV-E	MOV	109300130	VALVE HAS BODY BONNET LEAK	REPLACED GASKET	811001	BL
1-MOV-F	MOV	110011750	MOV INDICATE CLOSED LOCALLY	COMPLETED - VALVE DOES NOT WORK SAT	811001	PG

\* PMS - PREVENTIVE MAINTENANCE    BL - BOUNDARY LEAK    VOID - VOIDED    MD - MINOR DEFICIENCY    SL - SEAT LEAKAGE  
 DC - DESIGN CHANGE    PG - PLUGGING FAILURE    SWITCH - NON-FUNCTIONAL FAILURE OF LIMIT SWITCH



Table B.1.c. (continued)

MARK NO.	COMPONENT	M. R. #	PROBLEM DESC	MODE/MECHANISM(if applicable) HISTORY SUMMARY	RTSVDT	CLASSIFICATION*
1-MOV-A	MOV	905180841	LEAKS THROUGH	VOID	811024	VOID
1-MOV-E	MOV	905180843	LEAKS THROUGH	VOID	811024	VOID
1-MOV-F	VALVE	112050738	VALVE INDICATES INTERMITTENT POSITION	LIMITS ADJUSTED, SATISFACTORY	811206	SWITCH
2-MOV-C	VALVE	111121519	REPAIR GEAR BOX	RENEWED BEVEL GEAR	811207	PG
2-MOV-C	MOV	112211400	INTERMEDIATE INDICATION	VALVE OPERATES SATISFACTORY	811223	SWITCH
1-MOV-F	VALVE	201140700	1-MOV-F FAILS TO INDICATE FULLY	ADJUSTED VALVE, SATISFACTORY	820114	SWITCH
1-MOV-F	MOV	201072020	INTERMEDIATE INDICATION ON VALVE	VOID	820115	VOID
1-MOV-C	INSTR	203201713	VALVE SHOWS INTERMEDIATE INDICATION	ADJUSTED LIMITS, CYCLED SATISFACTORY	820407	SWITCH
2-MOV-C	MOV	204090840	INTERMEDIATE LIGHT	REPLACED LIMIT SWITCH, TESTED SAT	820409	SWITCH
2-MOV-F	VALVE	204121330	BODY TO BONNET LEAK	TIGHTENED BONNET NUTS ON VALVE	820412	BL
2-MOV-E	MOV	204092327	BODY TO BONNET	VOID	820415	VOID
1-MOV-F	MOV	205120140	VALVE WOULD NOT CLOSE FULLY	VOID	820517	VOID
2-MOV-F	VALVE	205201502	DISCONNECT/RECONNECT FOR MECH DEPT	RECONNECTED, TESTED SAT	820522	PMS
2-MOV-F	VALVE	206090901	FURMANITE BODY TO BONNET LEAK	VOID	820615	VOID
2-MOV-D	VALVE	204090700	VALVE DOES NOT CLOSE	VOID - NO WORK PERFORMED, OPER DIDN'T HO	820809	VOID
1-MOV-F	SWITCH	203120415	VALVE CYCLES NORMALLY, HOWEVER, LIGHT	WORK PERFORMED ON MRS 1208120135	820814	VOID
1-MOV-F	MOV	208140700	CHANGE LIMITORQUE	INSTALLED NEW LIMITORQUE	820814	PG
1-MOV-F	MOV	208120135	VALVE WILL NOT OPERATE BREAKER THERM	DISCONNECTED/RECONNECTED SATISFACTORY	820814	PG
1-MOV-F	VALVE	208141901	VALVE MOVES SLOW PER PT 18.6, INSPECT	VOID - COMPLETED ON MR 0208140700	820827	VOID
1-MOV-F	MOV	210130602	VALVE WILL NOT FULLY CLOSE	DISCONNECTED/RECONNECTED MOV, SAT	821014	PG
1-MOV-C	VALVE	210130858	PACKING LEAK	REPACKED VALVE	821015	BL
1-MOV-E	VALVE	210151232	VALVE HAS SLIGHT PACKING LEAK	ADJUSTED PACKING	821018	BL
1-MOV-E	VALVE	210141540	ADJUST LIMIT SWITCH	CYCLED SATISFACTORY	821018	SWITCH
1-MOV-F	VALVE	210151234	VALVE HAS PACKING LEAK	ADJUSTED PACKING	821018	BL
1-MOV-F	MOV	210140101	MOV WILL NOT CLOSE	REMACHINED SEAT RING	821018	PG
2-MOV-A	VALVE	204150708	DISCONNECT/RECONNECT FOR MECHANICS	DISCONNECT/RECONNECT, TESTED SAT	821211	PMS
2-MOV-A	VALVE	203010317	VALVES LEAK BY WHEN SHUT	INSPECTED, FOUND NOTHING WRONG	821212	PMS
2-MOV-B	VALVE	204150711	DISCONNECT/RECONNECT FOR MECHANICS	RECONNECTED, TESTED SATISFACTORY	821214	PMS
2-MOV-B	VALVE	212101721	DISCONNECT/RECONNECT FOR MECHANICS	VOID - DUPLICATE WKPERF ON MR 0204150711	821214	VOID
2-MOV-B	VALVE	212101720	OVERHAUL	MANUFACTURED AND INSTALLED	821216	SL
1-MOV-F	MOV	209081016	DISASSEMBLE LIMITORQUE	VOID - NOT ENOUGH LEFT TO REBUILD	821218	VOID
2-MOV-BDF	CONTROL	212172011	WHEN LO-LO S/G LEVEL WAS RECEIVED	REWired BREAKERS AS	821218	PG
2-MOV-A	MOV	212151515	BODY TO BONNET LEAK	REPLACED BONNET GASKET	821221	BL
2-MOV-A	MOV	212161045	DISCONNECT/RECONNECT FOR MECHANICS	RECONNECTED, TESTED SATISFACTORY	821221	PMS

\* PMS - PREVENTIVE MAINTENANCE    BL - BOUNDARY LEAK    VOID - VOIDED    MD - MINOR DEFICIENCY    SL - SEAT LEAKAGE  
 DC - DESIGN CHANGE    PG - PLUGGING FAILURE    SWITCH - NON-FUNCTIONAL FAILURE OF LIMIT SWITCH

Table B.1.c. (continued)

MARK NO.	COMPONENT	M. R. #	PROBLEM DESC	MODE/MECHANISM(if applicable) HISTORY SUMMARY	RTSVDT	CLASSIFICATION*
1-MOV-E	MOV	303100215	AGASTAT CONTACT IS STICKING	ADJUSTED MICROSWITCH	830313	PG
1-MOV-C	VALVE	302131114	VALVE LEAK BY	COMPLETED	830314	SL
1-MOV-E	VALVE	302131004	PACKING LEAK	COMPLETED	830314	BL
1-MOV-A	VALVE	302131117	VALVE LEAKS BY	OVERHAULED VALVE	830315	SL
1-MOV-F	VALVE	302131001	PACKING LEAK	VOID COMP UNDER MR 302131109	830318	VOID
1-MOV-B	VALVE	302131115	VALVE LEAKS BY	OVHL VALVE + REPLACED	830321	SL
1-MOV-D	VALVE	302131111	VALVE LEAKS BY	OVHL VALVE + REPACKED	830321	SL
1-MOV-F	VALVE	302131109	VALVE LEAKS BY	OVHL VALVE	830321	SL
1-MOV-B	MOV	303162000	DISC/RECON FOR MECHS	VOID DISC/REC PERF BY DANIELS	830406	VOID
1-MOV-C	MOV	303162001	DISC/RECON FOR MECHS	VALVE RECONNECTED	830406	PMS
1-MOV-D	MOV	303162002	DISC/RECON FOR MECHS	VOID DISC/REC PERF BY DANIELS	830406	VOID
1-MOV-B	MOV	304071316	PACKING LEAK	ADJUSTED PACKING	830411	BL
1-MOV-D	VALVE	304072030	VALVE OPENS BUT WILL NOT CLOSE	ADJUSTED LIMITS	830411	PG
1-MOV-E	VALVE	304072057	VALVE LEAKS	INVESTIGATE LEAK	830417	SL
1-MOV-F	VALVE	304072101	VALVE LEAKS BY SEAT	INVESTIGATE LEAK	830417	SL
1-MOV-C	MOV	304230521	VALVE MOTOR IS LOOSE	DISCONNECTED AND	830423	PG
2-MOV-F	VALVE	304240145	VLV WHEN CLOSED CAME BACK OPEN	VALVE CYCLED SAT	830424	PG
1-MOV-E	LIMITORQ	304130900	VALVE LEAKS THRU	VALVE CYCLED SAT	830426	PMS
1-MOV-F	MOV	304130905	VALVE LEAKS THRU	VALVE CYCLED SAT	830426	PMS
2-MOV-C	VALVE	304230659	DRIVE MECHANISM BROKEN	REPLACED DESTROYED MOV WITH NEW MOV	830426	PG
1-MOV-B	MOV	304260408	OPENING TIME IS GREATER THAN 25 PERC	PT 18.6 UPDATED	830505	MD
1-MOV-C	MOV	304260411	OPENING TIME IS GREATER THAN 25 PERC	PT 18.6 UPDATED	830505	MD
1-MOV-E	MOV	304260421	OPENING TIME IS GREATER THAN 25 PERC	PT 18.6 UPDATED	830505	MD
1-MOV-B	MOV	305061620	REPLACE OVERLOAD ASSEMBLY	REPLACED OVERLOADS	830511	DC
1-MOV-D	MOV	305061618	REPLACE OVERLOAD	REPLACED OVERLOADS	830511	DC
1-MOV-F	MOV	305061617	REPLACE OVERLOAD	REPLACED OVERLOADS	830511	DC
1-MOV-D	MOV	305111830	VALVE CLOSSES	CYCLED VALVE	830520	PG
2-MOV-A	COUPLING	306061519	FLEXIBLE COUPLING LEAKS	REPLACED LEAKING TUBE	830608	MD
2-MOV-C	VALVE	305131902	MOV EXCEEDS INVESTIGATE CAUSE	VOID DUPLICATE MR	830616	VOID
2-MOV-C	MOV	304231524	INSTALL LOCAL INDICATING ROD ON MOV	FABRICATED + INSTALLED INDICATOR	830810	PMS
2-MOV-F	MOV	307050610	MOV WONT STAY CLOSED	CYCLED SAT	830819	PG
2-MOV-E	MOV	308120142	2-MOV-E HAS BODY TO BONNET LEAK	TIGHTENED ALL NUTS	830822	BL
2-MOV-C	MOV	306121830	STRK TIME GREATER THAN 25 PERC	ENGINEERING TO EVALUATE STROKE	830913	MD
1-MOV-F	VALVE	210130601	VALVE WILL NOT GO FULLY CLOSED	VOID	831019	VOID

\* PMS - PREVENTIVE MAINTENANCE    BL - BOUNDARY LEAK    VOID - VOIDED    MD - MINOR DEFICIENCY    SL - SEAT LEAKAGE  
 DC - DESIGN CHANGE    PG - PLUGGING FAILURE    SWITCH - NON-FUNCTIONAL FAILURE OF LIMIT SWITCH

Table B.1.c. (continued)

MARK NO.	COMPONENT	M. R. #	PROBLEM DESC	MODE/MECHANISM(if applicable) HISTORY SUMMARY	RTSVDT	CLASSIFICATION*
2-MOV-A	MOV	312120912	WRONG PLUG IN BOTTOM OF MOV	CORRECT PLUG INSTALLED	840107	MD
2-MOV-C	MOV	312120910	WRONG PLUG IN BOTTOM OF MOV	CORRECT PLUG INSTALLED	840107	MD
2-MOV-E	MOV	312120911	WRONG PLUG IN BOTTOM OF MOV	CORRECT PLUG INSTALLED	840107	MD
1-MOV-B	MOV	401271144	LIFT LEAD AS REQUESTED BY OPS	VOID	840130	VOID
1-MOV-C	MOV	410271145	LIFT LEAD AS REQUESTED BY OPERATORS	VOID	840130	VOID
1-MOV-D	MOV	402251534	LIMIT SWITCH DOES NOT MAKEUP	CYCLED VALVE	840309	SWITCH
2-MOV-B	VALVE	403140646	DISCONNECT AND RECONNECT VALVE	ADJUSTED LIMITS, RECONNECTED LOAD	840326	PMS
2-MOV-D	VALVE	403131424	ELECTRICAL DISCONNECT/RECONNECT VALVE	RECONNECTED LOAD CHECK BRIDGE & MEGGER	840330	PMS
2-MOV-F	VALVE	403140648	DISCONNECT AND RECONNECT VALVE	RECONNECTED LOAD, CHECKED BRIDGE & MEG	840330	PMS
1-MOV-C	VALVE	403290922	OPEN, INSPECT, REPAIR	VOID - VERIFIED NO LEAK BY	840404	VOID
1-MOV-E	VALVE	403290924	OPEN, INSPECT, AND REPAIR	VOID - VERIFIED NO LEAK BY	840404	VOID
2-MOV-A	VALVE	403140728	SUSPECT VALVE LEAKING AT SEAT	DISASSEMBLED VALVE CRACKED	840406	SL
2-MOV-A	VALVE	403140645	DISCONNECT AND RECONNECT VALVE	DISCONNECTED AND RECONNECTED AS	840406	PMS
2-MOV-A	MOV	403311426	BODY TO BONNET LEAK	TORQUED BOLTS	840406	BL
2-MOV-B	AGASTAT	404010900	CLEAN AGASTAT	CLEANED AGASTAT AND OPERATED	840406	PMS
2-MOV-B	VALVE	403140729	SUSPECT VALVE LEAKING BY SEAT	DISASSEMBLED VALVE CRACKED	840406	SL
2-MOV-B	VALVE	403310711	OPEN, INSPECT, REPAIR	DISASSEMBLED VALVE TACK WELDED PLUG	840406	MD
2-MOV-B	VALVE	403310712	DISCONNECT/RECONNECT FOR MAINTENANCE	DISCONNECTED AND RECONNECTED MOTOR	840406	PMS
2-MOV-C	VALVE	403131423	ELECTRICAL DISCONNECT/RECONNECT VALVE	DISCONNECTED AND RECONNECTED AS	840406	PMS
2-MOV-C	VALVE	308061207	REPAIR VALVE	DISASSEMBLED VALVE CRACKED	840406	SL
2-MOV-D	VALVE	403310710	OPEN, INSPECT, AND REPAIR	CLEANED FOR TACKING TACH WELD PLUG	840406	MD
2-MOV-D	VALVE	403300845	DISCONNECT AND RECONNECT VALVE	DISCONNECTED/RECONNECTED MOTOR	840406	PMS
2-MOV-D	VALVE	308061209	REPAIR VALVE	DISASSEMBLED VALVE CRACKED	840406	SL
2-MOV-E	AGASTAT	404011400	CLEAN AGASTAT	CLEANED AGASTAT AND OPERATED SAT	840406	PMS
2-MOV-E	VALVE	403140647	DISCONNECT AND RECONNECT VALVE	DISCONNECTED AND RECONNECTED AND	840406	PMS
2-MOV-E	VALVE	403140730	SUSPECT VALVE LEAKING BY SEAT	DISASSEMBLED VALVE CRACKED	840406	SL
2-MOV-F	VALVE	403140731	SUSPECT VALVE LEAKING BY SEAT	DISASSEMBLED VALVE CRACKED	840406	SL
2-MOV-F	VALVE	403300847	DISCONNECT AND RECONNECT MOV	DISCONNECTED AND RECONNECTED	840406	PMS
1-MOV-E	VALVE	403290930	ELECTRICAL DISCONNECT AND RECONNECT	VOID - NOT TO BE WORKED	840410	VOID
2-MOV-F	VALVE	401131605	VALVE OPENS	AGASTAT STICKING	840412	PG
1-MOV-F	VALVE	403290931	ELECTRICAL DISCONNECT AND RECONNECT	DISCONNECTED AND RECONNECTED	840417	PMS
1-MOV-F	VALVE	404142132	REPAIR PACKING LEAK	VOID - COMPLETED ON MR 1404142131	840417	VOID
1-MOV-F	VALVE	404142131	REPAIR BODY TO BONNET LEAK	TORQUED BODY TO BONNET	840417	BL
1-MOV-B	VALVE	403290927	ELECTRICAL DISCONNECT AND RECONNECT	VOID - NO WORK NEEDS TO BE PERFORMED	840419	VOID

\* PMS - PREVENTIVE MAINTENANCE    BL - BOUNDARY LEAK    VOID - VOIDED    MD - MINOR DEFICIENCY    SL - SEAT LEAKAGE  
 DC - DESIGN CHANGE    PG - PLUGGING FAILURE    SWITCH - NON-FUNCTIONAL FAILURE OF LIMIT SWITCH

Table B.1.c. (continued)

MARK NO.	COMPONENT	M. R. #	PROBLEM DESC	MODE/MECHANISM(if applicable) HISTORY SUMMARY	RTSVDT	CLASSIFICATION*
1-MOV-C	VALVE	403290928	ELECTRICAL DISCONNECT AND RECONNECT	VOID - NO WORK PERFORMED	840419	VOID
1-MOV-D	VALVE	403290932	ELECTRICAL DISCONNECT AND RECONNECT	VOID - NO WORK PERFORMED	840419	VOID
1-MOV-A	VALVE	403290926	ELECTRICAL DISCONNECT AND RECONNECT	DISCONNECTED AND RECONNECTED FOR	840420	PMS
1-MOV-A	VALVE	403280920	OPEN, INSPECT, REPAIR	REPAIRED VALVE	840428	SL
1-MOV-E	VALVE	210151233	VALVE HAS SLIGHT PACKING LEAK	VOID	840516	VOID
1-MOV-D	VALVE	406140300	LIMITS NOT WORKING	REPLACED LIMIT SWITCH, GEAR WORN	840614	PG
1-MOV-D	VALVE	406131858	THERMALS BREAKER OPENING	VOID - COMPLETED ON 1406140306	840615	VOID
1-MOV-D	VALVE	406191135	REPAIR/REPLACE GEAR ASSEMBLY	INSPECTED, FOUND LIMITORQUE SAT	840620	PG
1-MOV-D	VALVE	406190408	VALVE WON'T CLOSE OR OPEN	REPLACED LIMITS, DISCONNECTED	840620	PG
1-MOV-F	VALVE	405120310	STROKE TIME EXCEEDED REFERENCE	STROKE TIME OF VALVE BEING CHANGED	840623	MD
1-MOV-A	VALVE	407021902	HANDLE LOOSE	INSTALLED WASHER	840706	MD
1-MOV-D	VALVE	406200605	REPLACE 1 INCH, 45 DEGREE CONNECTOR	REPAIRED FLEX TO LIMIT SWITCH	840724	MD
1-MOV-A	BREAKER	407251001	INCREASE OVERLOADS TO SIZE 1024	REPLACED OVERLOADS WITH CORRECT SIZE	840726	DC
1-MOV-B	BREAKER	407251002	REPLACE OVERLOADS WITH SIZE 1024	REPLACED OVERLOADS WITH CORRECT SIZE	840726	DC
1-MOV-C	BREAKER	407251003	REPLACE OVERLOADS WITH SIZE 1024	REPLACED OVERLOADS WITH CORRECT SIZE	840726	DC
1-MOV-D	BREAKER	407251004	REPLACE OVERLOADS WITH SIZE 1024	REPLACED OVERLOADS WITH CORRECT SIZE	840726	DC
1-MOV-E	BREAKER	407251005	REPLACE OVERLOADS WITH SIZE 1024	REPLACED OVERLOADS WITH CORRECT SIZE	840726	DC
1-MOV-F	BREAKER	407251006	REPLACE OVERLOADS WITH SIZE 1024	REPLACED OVERLOADS WITH CORRECT SIZE	840726	DC
1-MOV-D	BREAKER	407271235	PERFORM TEP-5	PERFORMED TEP-5 BREAKER	840727	PMS
2-MOV-A	BREAKER	407251007	REPLACE OVERLOADS WITH SIZE 1024	VOID - TO BE COMPLETED ON WO 002943	840816	VOID
2-MOV-B	BREAKER	407251008	REPLACE OVERLOADS WITH SIZE 1024	VOID - TO BE COMPLETED ON WO 002944	840816	VOID
2-MOV-B	VALVE	405122130	EXCESSIVE STROKE TIME	VOID - TO BE COMPLETED ON WO 002140	840816	VOID
2-MOV-C	BREAKER	407251009	REPLACE OVERLOADS WITH SIZE 1024	VOID - TO BE COMPLETED ON WO 002945	840816	VOID
2-MOV-D	BREAKER	407251010	REPLACE OVERLOADS WITH SIZE 1024	VOID - TO BE COMPLETED ON WO 002946	840816	VOID
2-MOV-D	VALVE	406091945	EXCEEDS STROKE TIME AS PER PT 18.6	VOID - TO BE COMPLETED ON WO 002382	840816	VOID
2-MOV-E	BREAKER	407251011	REPLACE OVERLOADS WITH SIZE 1024	VOID - TO BE COMPLETED ON WO 002947	840816	VOID
2-MOV-E	VALVE	405122135	EXCESSIVE STROKE TIME	VOID - TO BE COMPLETED ON WO 002141	840816	VOID
2-MOV-F	VALVE	407251012	REPLACE OVERLOADS WITH SIZE 1024	VOID - TO BE COMPLETED ON WO 002948	840816	VOID
2-MOV-F	VALVE	406091948	EXCEEDS STROKE TIME AS PER PT 18.6	VOID - TO BE COMPLETED ON WO 002385	840816	VOID
2-MOV-A	MOV	02943	REPLACE OVERLOADS W/SIZE IO 24	REPLACED OVERLOADS, VALVE CYCLED SAT BY OPS	840918	DC
2-MOV-B	MOV	02944	REPLACE OVERLOADS W/SIZE IO 24	OVERLOAD-HEADERS -2- 0735038 REPLACED OVERLOADS VALVE CYCLED SAT BY OPS OVERLOAD HEATERS -2- 0735038	840918	DC

B-30

\* PMS - PREVENTIVE MAINTENANCE    BL - BOUNDARY LEAK    VOID - VOIDED    MD - MINOR DEFICIENCY    SL - SEAT LEAKAGE  
DC - DESIGN CHANGE    PG - PLUGGING FAILURE    SWITCH - NON-FUNCTIONAL FAILURE OF LIMIT SWITCH

Table B.1.c. (continued)

B-31

MARK NO.	COMPONENT	M. R. #	PROBLEM DESC	MODE/MECHANISM(if applicable) HISTORY SUMMARY	RTSVDT	CLASSIFICATION*
2-MOV-C	MOV	02945	REPLACE OVERLOADS W/SIZE 10 24	INSTALL OVERLOADS. VALVE CYCLED SAT BY OPS OVERLOAD HEATERS -2- 0735038	840918	DC
2-MOV-D	MOV	02946	REPLACE OVERLOADS W/SIZE 10 24	REPLACED OVERLOADS. VALVE CYCLED SAT BY OPS OVERLOAD HEATERS -2- 0735038	840918	DC
2-MOV-E	MOV	02947	REPLACE OVERLOADS W/SIZE 10 24	REPLACED OVERLOADS. VALVE CYCLED SAT BY OPS OVERLOAD HEATERS -2- 0735038	840918	DC
2-MOV-F	MOV	02948	REPLACE OVERLOADS W/SIZE 10 24	REPLACED OVERLOADS. VALVE CYCLED SAT BY OPS OVERLOAD HEATERS -2- 0735038	840918	DC
1-MOV-B	MOV	1876	INSPECT VALVE	OPENED VALVE, INSPECTED INTERNALS, CLEANED PLUG AND SEAT, BLUED TO 100% CONTACT. REINSTALLED BODY TO BONNET.	841203	PMS
1-MOV-B	MOV	4484	DISCONNECT/RECONNECT MOV FOR MECH	DISCONNECTED MOV 10/24/84. VALVE RECONNECTED 10/26/84, BUT HAVE NOT CYCLED. CYCLED MOV-MOV-B .. OK.	841203	PMS
1-MOV-D	MOV	9491	REPAIR LINEAR INDICATION	GROUND INDICATION OUT OF BODY OF VALVE. MINIMUM WALL THICKNESS WAS NOT VIOLATED BY GRINDING. NDE PART AND REPORT SATISFACTORY.	841203	MD
1-MOV-D	MOV	1877	INSPECT VALVE	DISASSEMBLED VALVE, AND INSPECTED INTERNALS LAP SEAT AND PLUG AS NECESSARY.	841203	PMS
1-MOV-D	MOV	4483	DISCONNECT/RECONNECT 1-MOV-D	MOV DISCONNECTED, COVER HAS 3 BOLTS MISSING (10/24/84). RECONNECTED MOV-CH 11/24/84. CYCLED MOV-MOV-D , SATISFACTORY.	841203	PMS
1-MOV-F	MOV	1878	INSPECT VALVE	DISASSEMBLED BODY TO BONNET, INSPECTED INTERNALS, CLEANED PLUG AND SEAT, BLUED TO 100%, CONTACT	841203	PMS
1-MOV-F	MOV	4485	DISCONNECT/RECONNECT 1-MOV-F	MOV DISCONNECTED 10/24/84. VALVE RECONNECTED 10/26/84, BUT HAVE NOT CYCLED. CYCLED MOV-MOV-F , OK.	841203	PMS
1-MOV-F	MOV	10301	PACKING LEAK 1-MOV-F	EVENED OUT AND ADJUSTED PACKING GLAND, 4 FLATS ON GLAND NUTS. CYCLED VALVE TO ENSURE FREE MOVEMENT.	841207	BL
1-MOV-A	MOV	7118	1-MOV-A PMS	CYCLE VALVE, CHECK LIGHTS INDICATION, AND AMPS.	841213	PMS
1-MOV-B	MOV	7119	1-MOV-B PMS	PERFORMED PMS SATISFACTORY (11/30/84).	841213	PMS
1-MOV-D	MOV	7121	1-MOV-D PMS	PERFORMED PMS ON MOV-MOV-D (11/30/84).	841213	PMS
1-MOV-F	MOV	7123	1-MOV-F PMS	REMOVED MEGGERED MOTOR AND TOOK LOAD CHECK WHEN CYCLING VALVE, 11/30/84.	841213	PMS

\* PMS - PREVENTIVE MAINTENANCE    BL - BOUNDARY LEAK    VOID - VOIDED    MD - MINOR DEFICIENCY    SL - SEAT LEAKAGE  
 DC - DESIGN CHANGE    PG - PLUGGING FAILURE    SWITCH - NON-FUNCTIONAL FAILURE OF LIMIT SWITCH

Table B.1.c. (continued)

MARK NO.	COMPONENT	M. R. #	PROBLEM DESC	MODE/MECHANISM(if applicable) HISTORY SUMMARY	RTSVDT	CLASSIFICATION*
1-MOV-C	MOV	7120	1-MOV-C PMS	PERFORMED PMS SATISFACTORY (11/30/84).	841214	PMS
1-MOV-E	MOV	7122	1-MOV-E PMS	PERFORMED PMS, SATISFACTORY 11/30/84.	841214	PMS
2-MOV-F	MOV	20986	REPAIR VLV 2-MOV-F	VOID SELECTED AS REPETITIVE MAINT RM#02430	850204	VOID
1-MOV-F	MOV	13893	1-MOV-F BREAKER TRIPPED	BRIDGED AND MEGGERED SATISFACTORY, CYCLED SEVERAL	850213	PG
2-MOV-F	MOV	31197	2-MOV-F INSTALL T DRAIN	INSTALLED -T- DRAIN PLUG IN 2-MOV-F	850228	DC
2-MOV-B	MOV	11243	2-MOV-B AGASTAT TIMER	REPLACED AGASTAT TIMER, TESTED SAT.	850523	DC
2-MOV-A	MOV	11246	2-MOV-A AGASTAT TIMER	REPLACED AGASTAT TIMER CONNECTED L1-62 COIL LEADS	850531	DC
2-MOV-E	MOV	11244	2-MOV-E AGASTAT TIMER	REPLACED AGASTAT TIMER. L1-L2 COIL LEADS ONE CONNECTED. COMPLETED WD AGASTAT OK 5/31/85	850531	DC
2-MOV-D	MOV	11245	2-MOV-D AGASTAT TIMER	REPLACED AGASTAT, TESTED SAT.	850523	DC
2-MOV-F	MOV	13826	2-MOV-F REPLACE AGASTAT	REPLACED AGASTAT 4485 CYCLED SAT 6/1/85 AGASTAT 4605291	850601	DC
2-MOV-B	MOV	18180	2-MOV-B DISCONN/RECONN	DISCONNECTED MOV AS PER EMP-C-MOV-11. RECONNECTED MOTOR AND LIMITS ADJUSTED AS PER PROCEDURE EMP-C-MOV-11 UNABLE TO CHECK ROTATION OF MOTOR TASS MISSING 5/23/85	850605	PMS
2-MOV-D	MOV	18179	2-MOV-D DISCONN/RECONN	DISCONNECTED MOV AS PER EMP-C-MOV-11 4/8/85. RECONNECTED, COMPLETED STEPS 3.1-523 REQUIRE ELEC RUN AND LOAD CHECK. COMPLETED SAT	850605	DC
2-MOV-F	MOV	18178	2-MOV-F DISCONN/RECONN	DISCONNECTED MOV AS PER EMP-C-MOV-1 1 RECONNECTED MOV CABLE MARKINGS POOR. VALVE CYCLED SAT GASKET COVER 4606098	850605	PMS
2-MOV-E	MOV	20331	VALVE LEAKS THRU	VOID NOT LEAKING 6/12/85	850612	VOID
2-MOV-C	MOV	13787	2-MOV-B REPLACE AGASTAT	REPLACED AGASTAT TIMER CONNECTED 61-62 COIL LEADS 5/25/85 COMPLETED. MR AGASTAT 8<	850613	DC
2-MOV-A	MOV	20326	VALVE LEAKS THRU	VOID NOT LEAKING 6/17/85	850617	VOID
2-MOV-A	MOV	20830	INSPECT AS REQUIRED	INSPECT FOR MISSING ZERK FITTINGS NONE MISSING	850617	PMS
2-MOV-B	MOV	20436	2-MOV-B SWITCH COVER	INSTALLED SWITCH COVER SCREW	850617	MD
2-MOV-F	MOV	20327	VALVE LEAKS THRU	VOID NOT LEAKING	850617	VOID
2-MOV-B	MOV	20831	INSPECT	INSPECT FOR MISSING ZERK FITTINGS. NONE MISSING	850618	PMS
2-MOV-C	MOV	20832	INSPECT	INSPECT FOR MISSING ZERK FITTINGS. NONE MISSING	850618	PMS
2-MOV-D	MOV	20833	INSPECT	INSPECT FOR MISSING ZERK FITTING. NONE MISSING	850618	PMS
2-MOV-E	MOV	20834	INSPECT	INSPECT EDR MISSING ZERK FITTING. NONE MISSING	850618	PMS
2-MOV-F	MOV	20835	INSPECT	INSPECT FOR MISSING ZERK FITTING. NONE MISSING	850618	PMS

\* PMS - PREVENTIVE MAINTENANCE    BL - BOUNDARY LEAK    VOID - VOIDED    MD - MINOR DEFICIENCY    SL - SEAT LEAKAGE  
DC - DESIGN CHANGE    PG - PLUGGING FAILURE    SWITCH - NON-FUNCTIONAL FAILURE OF LIMIT SWITCH

Table B.1.c. (continued)

MARK NO.	COMPONENT	M. R. #	PROBLEM DESC	MODE/MECHANISM(if applicable) HISTORY SUMMARY	RTSVDT	CLASSIFICATION*
2-MOV-B	MOV	02140	EXCESSIVE STROKE TIME	DISASSEMBLE VALVE AND INSPECT PARTS	850620	PG
2-MOV-C	MOV	20360	INSTALL GREASE FITTING	INSTALL GREASE FITTING #2295726	850620	DC
2-MOV-D	MOV	02382	INVESTIGATE STROKE TIME	DISASSEMBLED VALVE CLEAN AND INSPECTED INTERNALS REASSEMBLED VALVE WITH NEW BONNET GASKET, STEM, PLUG AND ROTATE REPACKED VALVE	850620	PG
2-MOV-E	MOV	02141	OVERHAUL VALVE	REPACKED VALVE WITH GARLOCK 98	850620	PMS
2-MOV-E	MOV	20359	INSTALL GREASE FITTING	INSTALL GREASE FITTING #2295726	850620	DC
2-MOV-F	MOV	02333	INVESTIGATE STROKE TIME	DISASSEMBLED VALVE REPLACED STEM, DISC TORQUE KEY, GASKET DISC WASHER-100 PERCENT BLUE CHECK REASSEMBLED VALVE	850620	PG
2-MOV-E	MOV	20984	2-MOV-E ASSIST MECH	ADJUSTED TORQUE SWITCH SETTING TO 2	850624	PMS
2-MOV-F	MOV	20935	2-MOV-F ASSIST MECHS	VALVE CYCLED SAT AS PER OPERATIONS/ NO ADJUSTMENTS NECESSARY	850624	PMS
2-MOV-A	MOV	20983	2-MOV-A ASSIST MECH	VALVE CYCLED SAT AS PER OPERATIONS/ NO ADJUSTMENTS WERE NECESSARY	850626	PMS
2-MOV-E	MOV	18177	2-MOV-E DISCON/RECONN	VOID COMPLETED ON WO 020984	850627	VOID
2-MOV-A	MOV	13646	STROKE TIME EXCEEDS AVG PT18.6	VOID VALVE CYCLED SAT 6/20/85 NO WORK PERFORMED	850628	PMS
1-MOV-A	MOV	2275	REPLACE AGASTAT	VOID TO MR 1405251145.	850711	VOID
1-MOV-B	MOV	2276	REPLACE AGASTAT	VOID TO 1405251146.	850711	VOID
1-MOV-C	MOV	2277	REPLACE AGASTAT	VOID TO MR 1405251147.	850711	VOID
1-MOV-D	MOV	2278	REPLACE AGASTAT	VOID TO MR 1405251148.	850711	VOID
1-MOV-E	MOV	2279	REPLACE AGASTAT	VOID TO MR 1405251149.	850711	VOID
1-MOV-F	MOV	2280	REPLACE AGASTAT	VOID TO MR 1405251150.	850711	VOID
1-MOV-D	MOV	22962	1-MOV-D INVESTIGATE TRIP	WORKED WITH OPERATORS AND CYCLED VALVE; SATISFACTORY,NO PROBLEMS FOUND (OPEN 2.5 AMPS, CLOSED 2.5 AMPS).	850814	PG
2-MOV-B	MOV	42036	2-MOV-B PERFORM EWR WORK	INSTALLED NEW HEATERS AND CHANGED FIELD LEADS AS PER PROCEDURE 10/10/86. SET UP THRUST VALVES AS PER EWR	851012	DC
2-MOV-A	MOV	20540	2-MOV-A WONT XFER CONTR	REPLACED COIL ON LATCHING RELAY OLD COIL BURNT UP	851029	PG
2-MOV-A	MOV	25950	2-MOV-A INSTALL T-DRAIN	REPLACED OLD PLUGS WITH 2 BREATHER PLUGS IN MTR.	851101	DC
2-MOV-B	MOV	25949	2-MOV-B INSTALL T-DRAIN	REPLACED OLD PLUGS WITH 2 BREATHER PLUGS IN MTR	851101	DC
2-MOV-C	MOV	25948	2-MOV-B INSTALL T-DRAIN	REPLACE OLD PLUGS WITH 2 BREATHER LUGS IN MTR.	851101	DC
2-MOV-E	MOV	25946	2-MOV-E INSTALL T-DRAIN	REPLACED OLD PLUGS WITH 2 BREATHER LUGS IN MTR.	851101	DC

\* PMS - PREVENTIVE MAINTENANCE    BL - BOUNDARY LEAK    VOID - VOIDED    MD - MINOR DEFICIENCY    SL - SEAT LEAKAGE  
DC - DESIGN CHANGE    PG - PLUGGING FAILURE    SWITCH - NON-FUNCTIONAL FAILURE OF LIMIT SWITCH

Table B.1.c. (continued)

MARK NO.	COMPONENT	M. R. #	PROBLEM DESC	MODE/MECHANISM(if applicable) HISTORY SUMMARY	RTSVDT	CLASSIFICATION*
2-MOV-D	MOV	25947	2-MOV-D INSTALL T-DRAIN	REPLACED OLD PLUGS WITH -2- BREATHER PLUGS IN MTR REPLACED OLD PLUGS WITH 2 BREATHER PLUG IN MTR BAD GREASE/WRONG GREASE INSTALLED REMOVED DISASSEMBLED, CLEANED, REASSEMBLED AND INSTALLED. CHANGED OUT TRIGGER FINGER. PARTS -7/16- 9/16- 15/16- 1 1/16- BAD GREASE/WRONG KIND RMO, DISASSEMBLED, CLEANED, REPLACED AND LUBRICATED ACTUATOR, PLACED TRIGGER FINGER SPRING. PARTS- EXXON NEBULA EP-0 VOID - NOT REQUIRED AS PER ATTACHED MEMO. RESET THERMO OVERLOADS, TURNED BREAKER ON AND VALVE AUTOMATICALLY WENT OPEN DRAWING 2.7 AMPS. DREW 2.7 ALL THE WAY CLOSED, THEN DREW 11.3 AMPS. WE THINK THE TORQUE SWITCH IS BROKEN. AS FOUND - DISASSEMBLED LIMITORQUE, FOUND NO INTERNAL DAMAGE OF COMPONENTS. GREASE WAS VERY HARD, CLEANED ALL PARTS AND HOUSING,CHANGED OUT GREASE WITH EP-0, AND REASSEMBLED. DISCONNECTED MOTOR AND LIMIT SWITCH, 1/28/86. REMOVED LIMIT SWITCH AND TORQUE SWITCH. ALSO REMOVED MOTOR FOR MECHANICAL DEPARTMENT, 1/29/86. HOOKED UP AND PERFORMED EMP-C-MOV-11 SATISFACTORILY. LEAK/PACKING TIGHTENED PACKING. INVESTIGATION REVEALED THAT GREASE WAS NOT LEAKING, IT WAS JUST RECENTLY CHANGED AND THE GREASE THAT WAS SEEN WAS JUST EXCESS THAT DIDN'T GET WIPED OFF, GREASE WIPED OFF. BRIDGED AND MEGGERED TOO AMP READING. MOTOR PULLED HIGHER AMPS THAN NORMAL.	851104	DC
2-MOV-F	MOV	25945	2-MOV-F INSTALL T-DRAIN		851104	DC
2-MOV-D	MOV	38412	-L-ACTUATOR INSPECTION/REPAIR		851128	PMS
2-MOV-E	MOV	38413	-L-ACTUATOR INSPECTION/REPAIR		851128	PMS
1-MOV-F	MOV	2963	INVESTIGATE STROKE TIME		851213	VOID
1-MOV-D	MOV	29885	INVESTIGATE/REPAIR MOV		860128	PG
1-MOV-D	MOV	29920	E-INVESTIGATE/REPAIR AS REQUIRED		860131	PG
1-MOV-D	MOV	29937	1-MOV-D DISCONNECT/RECONNECT		860204	PMS
1-MOV-D	MOV	35288	PACKING ADJUSTMENT		860607	BL
1-MOV-D	MOV	30701	INVESTIGATE/REPAIR LEAK		860609	VOID
1-MOV-A	MOV	36114	EWR 85-018C, 85-261A, 85-224B		860610	PMS

B-34

\* PMS - PREVENTIVE MAINTENANCE    BL - BOUNDARY LEAK    VOID - VOIDED    MD - MINOR DEFICIENCY    SL - SEAT LEAKAGE  
DC - DESIGN CHANGE    PG - PLUGGING FAILURE    SWITCH - NON-FUNCTIONAL FAILURE OF LIMIT SWITCH



Table B.1.c. (continued)

MARK NO.	COMPONENT	M. R. #	PROBLEM DESC	MODE/MECHANISM(if applicable) HISTORY SUMMARY	RTSVDT	CLASSIFICATION*
1-MOV-A	MOV	35258	ACTUATOR INSTALLATION	GREASE/NORMAL WEAR DISASSEMBLED, CLEANED, INSPECTED ACTUATOR. REPLACED BAD GASKETS, AND SEAL O-RINGS. REINSTALLED AND LUBRICATED ACTUATOR. TOOLS 1-1/16 COMBINED. 18-	860611	PMS
1-MOV-D	MOV	35255	ACTUATOR INSPECTION	BAD LUBRICANT/WRONG LUBRICANT REMOVED ACTUATOR, DISASSEMBLED, CLEANED, INSPECTED, REPLACED GASKETS, AND LUBRICATED AND REINSTALLED.	860611	PMS
1-MOV-E	MOV	35254	ACTUATOR INSPECTION	GREASE/NORMAL WEAR DISASSEMBLED, CLEANED, INSPECTED ACTUATOR, REPLACED BAD GASKETS, O-RINGS, QUAD-RINGS, AND REINSTALLED AND LUBRICATED ACTUATOR.	860611	PMS
1-MOV-F	MOV	36992	1-MOV-F STATIC TEST	HIGH AMP READING, 6/17/86. ASSISTED MOVATS IN TESTING OF VALVE. VALVE OPERATED SATISFACTORY, 6/17/86. THRUST SETTINGS 15160, OPENED 15838.	860624	PMS
1-MOV-B	MOV	37045	MOV-B EWR 86-224, 85-224C	COMPLETED EWR 86-224-PI. FINAL THRUST VALVES NO. 16160 OPEN, NO. 16020 CLOSE.	860701	PMS
1-MOV-B	MOV	36362	MOV-B EWR 85-224B, 261A, 018C	RESET TORQUE SWITCH 5/31/86. PERFORMED EWR 85-224B, 85-01, AND 85-261A.	860702	PMS
1-MOV-F	MOV	37040	MOV-F EWR 86-224, 85-224C	COMPLETED EWR 86-224-P1. VALVE OPERATED SATISFACTORY, 6/20/86.	860702	PMS
1-MOV-D	MOV	36367	MOV-D EWR, 85-224B, 261, 018C	MADE ADJUSTMENTS ON TORQUE SWITCH OLD SETTING, 2-1/4 OPEN; 2-1/4 CLOSE. CHANGE TO 2-3/8 OPEN; 2-3/8 CLOSE. PERFORMED EWR 85-224B, 85-068C, AND	860705	PMS
1-MOV-D	MOV	37043	MOV-D EWR 86-224, 85-224C	COMPLETED EWR 86-224-PI, COMPLETED EMP-COMOV-151, COMPLETED EMP-C-MOV-18, RETAGGED MOV-MOV-D . TAG REPORT NO. SI-8318	860705	PMS
1-MOV-E	MOV	36115	EWS 85-018C, 85-261A, 85-224B	BRIDGED AND MEGGERED, AND TOOK LOAD CHECK.	860705	PMS
1-MOV-E	MOV	37042	MOV-E EWR 86-224, 85-224C	COMPLETED EWR-86-224-P1, 6/16/86. ASSISTED MOVATS IN TESTING OF VALVE. COMPLETED EMP-C-MOV-151, VALVE OPERATED SATISFACTORY.	860705	PMS

\* PMS - PREVENTIVE MAINTENANCE    BL - BOUNDARY LEAK    VOID - VOIDED    MD - MINOR DEFICIENCY    SL - SEAT LEAKAGE  
DC - DESIGN CHANGE    PG - PLUGGING FAILURE    SWITCH - NON-FUNCTIONAL FAILURE OF LIMIT SWITCH

Table B.1.c. (continued)

MARK NO.	COMPONENT	M. R. #	PROBLEM DESC	MODE/MECHANISM(if applicable) HISTORY SUMMARY	RTSVDT	CLASSIFICATION*
1-MOV-F	MOV	35253	ACTUATOR INSPECTION	IMPROPER LUB./DIDN'T USE PRO SPECS REMOVED ACTUATOR FROM VALVE AND TOOK TO REFURBISHING SHOP. DISASSEMBLED ACTUATOR, CLEANED, INSPECTED, AND REPLACED ALL GASKETS.	860705	PMS
1-MOV-C	MOV	37044	MOV-C EWR 86-224, 85-224C	DELTA P - COMPLETED PROCEDURE AND EWR 86-224-PI ON 6-24-86, FIND THRUST.	860706	PMS
1-MOV-F	MOV	37650	1-MOV-F TEST WITH MOVATS	MOVAT TEST COMPLETED.	860706	PMS
1-MOV-B	MOV	35257	ACTUATOR INSPECTION	REMOVED, DISASSEMBLED, CLEANED, AND INSPECTED CASE AND MECHANICAL PARTS. REPLACED GASKETS, O-RINGS, AND QUAD-RINGS. REASSEMBLED AND REINSTALLED.	860707	PMS
1-MOV-C	MOV	35256	ACTUATOR INSPECTION	GREASE/NORMAL WEAR DISASSEMBLED, CLEANED, INSPECTED ACTUATOR, AND REPLACED ALL.	860707	PMS
1-MOV-A	MOV	37037	1-MOV-A EWR 86-224	REMOVED FROM LIST - LEADS FROM OPEN SIDE OF TORQUE SWITCH, NO. 18 AND CONTROL LEAD 43. CONNECTED LEAD 43 AND OPENED SIDE OF TORQUE SWITCH NO. 18, LEADS TO LS 13.	860708	PMS
1-MOV-D	MOV	37465	1-MOV-D EWR 85-224C	PERFORMED EWR 85-244C AND TESTED IN ACCORDANCE WITH PROCEDURE, 6/23/86. FINAL THRUST VALVES CLOSE AT 15,180 LBS, OPEN AT 15,220 LBS.	860715	PMS
1-MOV-F	MOV	37058	MOV-F EWR 85-224B, 261A, 018C	HIGH AMP READING. REPLACED OLD HEATER COILS.	860717	PMS
2-MOV-D	MOV	37688	2-MOV-D WILL NOT OPEN	FAILURE/VALVE WOULD NOT OPER. AUX. CONTACTS STUCK. CHECKED AND FOUND AUX. CONTACTS WERE STUCK OPERATED AND CHECKED SAT.	860715	PG
2-MOV-A	MOV	42032	2-MOV-A PERFORM EWR.S	INSTALLED NEW HEATERS AND CHANGED FIELD LEADS AS PER PROCEDURE 1-/10/86. LOAD CHECKED/BRIDGE/MEGGER OPERATED SAT 10/15/86. PERFORMED	861015	DC
2-MOV-C	MOV	42038	2-MOV-B PERFORM EWR WORK	INSTALLED NEW HEATERS AND CHECKED FIELD LEAD TO BE SAT 10/10/86. EWR'S COMPLETED 2248 224H 018 261 10/15/86	861015	DC
2-MOV-E	MOV	42043	2-MOV-E PERFORM EWR WORK	PERFORMED EWR'S 85-018 AND 85-261 SAT 10/14/86 PERFORMED EWR 86-224B AND 85-224H AS STATED WITH MOVATS THRUST VALUES SET AS PER EWR-224H	861015	DC

\* PMS - PREVENTIVE MAINTENANCE    BL - BOUNDARY LEAK    VOID - VOIDED    MD - MINOR DEFICIENCY    SL - SEAT LEAKAGE  
DC - DESIGN CHANGE    PG - PLUGGING FAILURE    SWITCH - NON-FUNCTIONAL FAILURE OF LIMIT SWITCH

Table B.1.c. (continued)

MARK NO.	COMPONENT	M. R. #	PROBLEM DESC	MODE/MECHANISM(if applicable) HISTORY SUMMARY	RTSVDT	CLASSIFICATION*
2-MOV-D	MOV	42040	2-MOV-D PERFORM EWR WORK	INSTALLED HEATERS AND CHANGED FIELD LEADS AS PER PROCEDURE 10/10/86 PERFORMED EWR 86-2248 85-224H IAW MOVATS AND EMP-C-MOV- 10/24/86	861025	DC
2-MOV-F	MOV	42050	2-MOV-F PERFORM EWR WORK	PERFORMED EWR 85-018 + 85-261 + 86-224 AND TESTED VALVES PER EWR-85-224H AND MOVATS 10/13/86 NA/.	861025	DC
2-MOV-A	MOV	38409	ACTUATOR INSPECTION AND REPAIR	BAD GREASE/IMPROPER GREASE INSTALLED REMOVED ACTUATOR, TRASPORTED TO REFURB SHOP. DISASSEMBLED, CLEANED AND INSPECTED, REPLACED ALL SOFTWARE, REPLACE	861101	PMS
2-MOV-B	MOV	38410	ACTUATOR INSPECTION AND REPAIR	REMOVED ACTUATOR FROM VALVE & TRANSPORTED TO REFERB SHOP DISASSEMBLED CLEANED, INSPECTED, REPLACED ALL SOFTWARE & DEFECTIVE PARTS, REASSEMBLED USING EXXON NEBULA EP-O GREASE	861101	PMS
2-MOV-A	MOV	20987	REPAIR VLV 2-MOV-A	DISASSEMBLED VALVE IAW PROCEDURE & TAPED OPENING IN SYSTEM SHUT & ALL PARTS IN BAS BY VALVE BODY. LAPPED SEAT & PLUG REINSTALLED BONNET WITH NEW GASKET TROQUED TO 150 FT LBS.	861119	MD
2-MOV-F	MOV	38414	-L-ACTUATOR INSPECTION/REPAIR	REMOVED, DISASSEMBLED, CLEANED, INSPECTED, ASSEMBLED, LUBRICATED, & INSTALLED. BAD GREASE/. WRONG GREASE INSTALLED.	861119	PMS
2-MOV-F	MOV	43066	REPACK VALVE	UNPACKED AND REPACKED VALVE WITH GARLOCK 98.	861119	PMS
2-MOV-E	MOV	20988	REPAIR VLV 2-MOV-E	VOID TO 038413	861120	VOID
1-MOV-D	MOV	45967	INVESTIGATE/REPAIR AS NEEDED	ASSISTED OPERATORS IN OPENING VALVE FULLY FROM MCC. VALVE WENT FULL OPEN, FULL CLOSE WITH PROPER INDICATION. WORK PERFORMED ON WO 047506, 1/8/87.	861123	PG
2-MOV-C	MOV	38411	-L-ACTUATOR INSPECTION/REPAIR	BAD GREASE/WRONG GREASE INSTALLED REMOVED DISASSEMBLED, CLEANED, INSPECTED, ASSEMBLED, LUBRICATED, INSTALLED. TOOLS-9/16 1/2 7/16 COMBINATION 5/16 3/8 ALLEN	861128	PMS
2-MOV-B	MOV	45784	2-MOV-B ADJUST LIMITS	REPAIRED PRONG ON MOV. NEEDED SMALL ADJUSTMENT CYCLED 5 TIMES. EVERYTHING RAN SAT.	861204	SWITCH

\* PMS - PREVENTIVE MAINTENANCE BL - BOUNDARY LEAK VOID - VOIDED MD - MINOR DEFICIENCY SL - SEAT LEAKAGE  
DC - DESIGN CHANGE PG - PLUGGING FAILURE SWITCH - NON-FUNCTIONAL FAILURE OF LIMIT SWITCH

B-37

Table B.1.c. (continued)

MARK NO.	COMPONENT	M. R. #	PROBLEM DESC	MODE/MECHANISM(if applicable) HISTORY SUMMARY	RTSVDT	CLASSIFICATION*
1-MOV-D	MOV	47664	ACTUATOR GREASE REPLACEMENT	REPLACED GREASE/PM REMOVED TOP COVER AND CHECKED GREASE, PULLED SIDE PLUG AND CHECKED SAMPLE OF GREASE. DRAINED OUT GREASE AND FILLED TO LEVEL WITH NEW GREASE.	870106	PMS
1-MOV-C	MOV	47314	P,E-OVERHAUL MOV	CLEAN SPRING PAK./PM REMOVED MOTOR, REPLACED GREASE, REMOVED WORM/TORQUE SPRING ASSEMBLY, CLEANED, GREASED, AND REINSTALLED.	870108	PMS
1-MOV-D	MOV	46491	1-MOV-D ADJUST INDICATOR SWITCH	VOID - TO BE COMPLETED ON 047506	870109	VOID
1-MOV-F	MOV	49034	1-MOV-F INSPECT HOOK-UP	MOTOR HEATER LEADS ARE NOT TERMINATED, 1/31/87. REMOVED LIMIT COVER. LEADS FOR MOTOR HEATERS ARE TOO SHORT TO TERMINATE PROPERLY WITHOUT REMOVING GEARBOX.	870201	MD
1-MOV-E	MOV	49801	INVESTIGATE MALFUNCTION	VALVE WOULDN'T OPEN/AUXILIARY OPEN INTERLOCK STUCK ON OPENING CIRCUIT. REPLACED CONTACTOR 2/18/87, CHECKED SATISFACTORY. TIMES. FLA 2.4 ACTUAL, T1 2.4, T2 2.4, AND T3 2.4 OKAY.	870219	PG
2-MOV-C	MOV	46218	REPAIR VALVE	SPRING PACK DISASSEMBLED 12/30/86. S/N 347490. INSTALLED SPRING PACK ONLY. LEFT WITH MOVAT. WORK WAS PERFORMED BY MOVAT.	870225	PG
1-MOV-C	MOV	49725	1-MOV-C CHECK LOGIC, CKT	VALVE WOULDN'T OPEN/INCORRECT WIRING STARTED TROUBLE SHOOTING. FOUND ONE AGASTAT WIRE IN WRONG PLACE. RETURNED TO PROPER PLACE AS PER VALVE WOULDN'T OPEN/INCORRECT WIRING	870304	NAF
1-MOV-D	MOV	49735	1-MOV-D CHECK LOGIC CKT	FOUND X1 LANDED ON WRONG TERMINAL ON AGASTAT. RELANDED CORRECTLY AS ESK 6BY. FOUND IT ON NO. 1 CONTACT.	870304	NAF
2-MOV-C	MOV	49525	2-MOV-B DELTA-R TESTING	PERFORMED DELTA R. EVERYTHING WORKED FINE 3/6/87 VALVE WAS CYCLED SATISFACTORY DURING ACTUAL FLOW CONDITION. THRUST VALVE RECORDED DURING CLOSE VOID TO 040444	870316	PMS
2-MOV-F	MOV	45553	2-MOV-F HIGH AMP READING		870501	VOID

\* PMS - PREVENTIVE MAINTENANCE    BL - BOUNDARY LEAK    VOID - VOIDED    MD - MINOR DEFICIENCY    SL - SEAT LEAKAGE  
DC - DESIGN CHANGE    PG - PLUGGING FAILURE    SWITCH - NON-FUNCTIONAL FAILURE OF LIMIT SWITCH    NAF - NOT AN AGING FAILURE (MAINTENANCE ERROR)

Table B.1.d. MAINTENANCE RECORDS FOR THE AUXILIARY FEEDWATER SYSTEM 6-INCH MOTOR OPERATED VALVES

MARK NO.	COMPONENT	M. R. #	PROBLEM DESC	MODE/MECHANISM(if applicable) HISTORY SUMMARY	RTSVOT	CLASSIFICATION*
2-MOV-I	MOV	20160580	PERFORM EMP-P-MOV-45	COMPLETED	770928	PMS
1-MOV-G	MOV	805091028	CLEAN AND INSPECT	VOID	780718	VOID
1-MOV-H	MOV	805091029	CLEAN AND INSPECT	VOID	780718	VOID
2-MOV-J	VALVE	810030726	WILL NOT OPERATE	MEG BRIDGED AND TESTED SATISFACTORY	781006	FC
2-MOV-J	MOV	812040631	THERMALS OUT WON'T OPEN	CLEANED, CHECKED MOTOR - TEST SAT	781204	FC
1-MOV-G	MOV	910230641	MOV WILL NOT OPEN	VOID	791024	VOID
1-MOV-H	MOV	4262145	MANUAL ENGAGEMENT HANDLE	VALVE OPERATES OK	800429	VOID
1-MOV-G	MOV	909111345	VALVE BINDING	VOID	800522	VOID
2-MOV-I	VALVE	7301209	DISCONNECT FOR MECHANICS	CONNECTED - TESTED SAT	800801	PMS
2-MOV-I	MOV	7231425	VALVE IS BINDING UP	REPAIRED VALVE	800801	FC
2-MOV-I	MOV	8050929	REPLACE LIMITORQUE	REPAIRED LIMITORQUE OPERATOR	800807	FC
2-MOV-I	MOV	8050855	DISCONNECT/RECONNECT FOR MECHS	COMPLETED AS PER EMP-C-MOV-11	800808	PMS
2-MOV-J	MOV	8122234	VALVE WILL NOT COME FULL OPEN	NO PROBLEMS FOUND	800814	FC
2-MOV-J	VALVE	101131200	VALVE BINDS UNABLE TO CLOSE	CLEANED, STEM THREADS	810120	FC
2-MOV-J	VALVE	101131201	DISCONNECT/RECONNECT FOR MECHANICS	MOV TESTED SATISFACTORY	810214	PMS
1-MOV-G	MOV	6120630	VALVE WILL NOT OPEN	COMPLETE	810423	FC
1-MOV-G	MOV	112120420	VALVE WILL NOT CYCLE	ADJUSTED LIMITS ON MOV-MOV-A , SAT	811212	FC
1-MOV-G	MOV	112150300	VALVE DOES NOT TRAVEL	VOID	811215	VOID
1-MOV-G	VALVE	107011537	VALVE BINDS UP	VOID - COMPLETED UNDER MR 112132230	820128	VOID
1-MOV-G	MOV	112241242	ELECTRICAL DISC LIMIT ON 1-MOV-A	RECONNECTED & TESTED SATISFACTORY	820205	PMS
1-MOV-G	MOV	112281344	DISCONNECT/RECONNECT MOV	VOID	820211	VOID
1-MOV-G	VALVE	112132230	WILL NOT FULLY CLOSE	VOID - UPDATING MR	820217	VOID
2-MOV-I	VALVE	304191635	VLV CYCLES HI AMPS ON MTR	ADJUSTED PACKING	830423	FC
2-MOV-I	VALVE	304231500	2-MOV-I WILL NOT OPEN	CLEANED TORQUE SWITCH	830423	FC
2-MOV-J	VALVE	304191637	VLV CYCLES HI AMPS ON MTR	ADJUSTED PACKING	830423	FC
2-MOV-J	VALVE	304231427	2-MOV-J WILL NOT OPEN	ADJUSTED TORQUE SWITCH	830423	FC
2-MOV-J	VALVE	308261835	LIMITORQUE GEARBOX LEAKING	FOUND NO GREASE LEAK ON MOV	830912	MD
2-MOV-I	VALVE	309051430	VALVE NOT FULLY CLOSED	CLEANED CONTACTS, TESTED SATISFACTORY	830913	SWITCH
2-MOV-I	MOV	308311504	REPLACE OR REPAIR FLEXIBLE CONDUIT	REPLACE FLEX COMPLETE	830913	MD
2-MOV-J	VALVE	304231705	VALVE WILL NOT OPEN	VOID	840130	VOID
2-MOV-I	VALVE	408050956	ADJUST PACKING OR REPLACE	ADJUSTED GLAND	840808	MD
2-MOV-I	MOV	03352	ADJUST PACKING OR REPLACE	VOID-NO PROBLEM EXISTS	850301	VOID
2-MOV-J	MOV	20409	2-MOV-J TORQUE SWITCH	CHECKED TORQUE SWITCH WITH PROCEDURE EMP-S-MOV-143	850610	PMS

\* PMS - PREVENTIVE MAINTENANCE    BL - BOUNDARY LEAK    VOID - VOIDED    MD - MINOR DEFICIENCY    SL - SEAT LEAKAGE  
 DC - DESIGN CHANGE    FC - CROSS-CONNECTING FAILURE    SWITCH - NON-FUNCTIONAL FAILURE OF LIMIT SWITCH

Table B.1.d. (continued)

MARK NO.	COMPONENT	M. R. #	PROBLEM DESC	MODE/MECHANISM(if applicable) HISTORY SUMMARY	RTSVDT	CLASSIFICATION*
2-MOV-J	MOV	43600	2-MOV-J INSP GREASE	CHECKED LUBRICANT FOUND IT NOT TO BE NEBULA ER-0 TOOLS 10- CRESENT WRENCH	851128	PMS
2-MOV-I	MOV	20406	2-MOV-I TORQUE SWITCH	CHECK TORQUE SWITCH PROCEDURE EMP-C-3PL-143	850610	PMS
1-MOV-G	MOV	23350	INVESTIGATE/REPAIR 1-MOV-G	REMOVED MOUNTING BOLTS FROM TORQUE SWITCH AND REPLACED THEM WITH THE RIGHT LENGTH BOLTS. TIGHTENED SECURELY AND REQUESTED OPERATORS TO CYCLE VALVE. VALVE OPERATED UNSATISFACTORY AND VOID - WORK TO BE DONE ON EW4 85-224A	850823	FC
1-MOV-G	MOV	10274	1-MOV-G ADJUST TORQUE	VOID - WORK TO BE DONE ON EW4 85-224A	851101	VOID
1-MOV-H	MOV	10275	1-MOV-H ADJUST TORQUE SWITCH	VOID - WORK TO BE DONE ON EWR 85-224A.	851101	VOID
1-MOV-H	MOV	26527	1-MOV-H CHECK CONTROLS	INVESTIGATED SWITCH, FOUND NO PROBLEM. CONTROL ROOM - CYCLED VALVE, NO PROBLEM WAS FOUND, SATISFACTORY VALVE, 11/13/85.	851114	VOID
1-MOV-H	MOV	30387	1-MOV-H WILL NOT STROKE	CYCLED VALVE SEVERAL TIMES, OPENED T1 2.4, T2 2.8, AND T3 2.9; CLOSED T1 2.8, T2 2.6, T3 2.6, FOUND NO PROBLEM AT THIS TIME.	860211	FC
1-MOV-H	MOV	32946	1-MOV-H REPAIR FLEX	NO PROBLEM FOUND.	860421	BL
1-MOV-H	MOV	35735	PERFORM EWR-85-224-B	ADJUSTED RESET AND PROPORTIONAL BAND ON CONTROLLER. CYCLING DAMPENED OUT, OPERATES GREASE CHANGEOUT/NEW TYPE GREASE	860517	PMS
1-MOV-G	MOV	38638	ACTUATOR GREASE REPLACEMENT	DISASSEMBLED MOV AND INSPECTED IAW PROCEDURE, ALL INTERNAL PARTS, SEALS, AND GASKETS. SEALS AND GASKETS SATISFACTORY, INTERNAL PART HARD TO OPERATE/DIRT ON STEM	860730	PMS
1-MOV-H	MOV	38692	ACTUATOR GREASE REPLACEMENT	DISASSEMBLED, CLEANED, REASSEMBLED, AND INSTALLED NEBULA EP-0 GREASE. VALVE TESTED SATISFACTORY ON OPERATION, WR 333665.	860806	PMS
1-MOV-H	MOV	39300	1-MOV-H REPLACE BEARINGS	MOTOR HOIST/BEARINGS BAD DISCONNECTED MOTOR, REPLACED BEARINGS, RECONNECTED AND CYCLED SATISFACTORY. RECONNECTED MOTOR TEST, RAN SATISFACTORY.	860807	FC
2-MOV-I	MOV	43599	2-MOV-I TNSP GREASE	CHECKED LUBRICANT. FOUND THAT IT IS NOT NEBULA EP-0 TOOLS- 10- CRESENT.	861128	PMS

\* PMS - PREVENTIVE MAINTENANCE    BL - BOUNDARY LEAK    VOID - VOIDED    MD - MINOR DEFICIENCY    SL - SEAT LEAKAGE  
 DC - DESIGN CHANGE    FC - CROSS-CONNECTING FAILURE    SWITCH - NON-FUNCTIONAL FAILURE OF LIMIT SWITCH

B-40

Table B.1.d. (continued)

MARK NO.	COMPONENT	M. R. #	PROBLEM DESC	MODE/MECHANISM(if applicable) HISTORY SUMMARY	RTSVDT	CLASSIFICATION*
1-MOV-H	MOV	33601	1-MOV-H CHECK BEARINGS	VOID - COMPLETED ON WO 039300. INSTALLED PIPE CAP.	860815	VOID
1-MOV-H	MOV	39313	INSTALL PIPE CAP		860902	MD
2-MOV-J	MOV	44510	REPLACE GREASE	BAD GREASE/WRONG GREASE INSTALLED CHANGED GREASE TO EXXON NEBULA EPO. PARTS-EXXON NEBULA EPO 0214701 GASKET SET 4610484	861122	PMS
2-MOV-I	MOV	10272	2-MOV-I RESET TORQUE	VOID TO 044985	861124	VOID
2-MOV-J	MOV	10273	2-MOV-J ADJUST TORQUE	VOID TO 044986	861124	VOID
2-MOV-I	MOV	44511	CHANGE OUT GREASE	BAD GREASE/WRONG GREASE INSTALLED DISASSEMBLED, CLEANED, REPLACE DEFECTED PARTS TIPPER FLANGE FINGER SPACER, UPPER RACE AND UPPER BEARING.	861128	PMS
1-MOV-G	MOV	35366	P,E-INVESTIGATE/REPAIR MOV	VOID - VALVE TESTED OPEN AT 65 SEC - MAXIMUM ALLOWABLE IS 90 SEC - IAW PT 18.6 AT STATIC CONDITION WITH NO DELTA-P ACROSS VALVE SATISFACTORY.	870115	VOID
2-MOV-J	MOV	45271	2-MOV-J HIGH AMPS	VOID...IN REVIEWING MOVATS TEST REPORT #2B1-11-886 THIS VALVE IS FULLY OPERABLE. A SLIGHT OVERCURRENT CONDITION CAN BE TOLERATED DUE TO IT BEING A NON CONTINUOUS DUTY MOTOR	870122	VOID

\* PMS - PREVENTIVE MAINTENANCE    VOID - VOIDED    MD - MINOR DEFICIENCY    SWITCH - NON-FUNCTIONAL FAILURE OF LIMIT SWITCH  
 FC - CROSS-CONNECTING FAILURE

B-41

Table B.1.e. MAINTENANCE RECORDS FOR THE AUXILIARY FEEDWATER SYSTEM 3-INCH CHECK VALVES

MARK NO.	COMPONENT	M. R. #	PROBLEM DESC	MODE/MECHANISM(if applicable) HISTORY SUMMARY	RTSVDT CLASSIFICATION*
1-CV-J	VALVE	4102000	INSPECT VALVE	REPAIRED VALVE	800415 LK
1-CV-H	VALVE	4150916	INSPECT INTERNALS AND REPAIR	REPAIRED VALVE	800417 LK
2-CV-J	VALVE	4170136	PULL AND INSPECT	INSPECTED SAT	800422 PMS
1-CV-I	VALVE	4150915	INSPECT INTERNALS AND REPAIR	INSPECTED AND REPAIRED VALVE	800424 LK
2-CV-I	VALVE	4170137	PULL AND INSPECT	INSPECTED SAT	800425 PMS
2-CV-H	VALVE	4170138	PULL AND INSPECT	COMPLETED	800426 PMS
1-CV-H	VALVE	8041550	CHECK VALVE LEAKING	WELDED PLUG AS PER REQUEST	801017 BL
2-CV-I	VALVE	101151201	NEEDS FURMANITE MATERIAL	COMPLETED	810123 BL
2-CV-I	VALVE	105010745	BODY TO BONNET LEAK	FURMANITE BONNET LEAK	810511 BL
2-CV-I	VALVE	107311540	FURMANITE HAS BEEN BEFORE	SEALED LEAK	810807 BL
1-CV-I	VALVE	109210813	OVERHAUL VALVE	COMPLETED AS ABOVE	810930 LK
1-CV-H	VALVE	109210811	OVERHAUL VALVE	COMPLETED AS ABOVE	810930 LK
1-CV-J	VALVE	109210815	OVERHAUL VALVE	COMPLETED AS ABOVE	810930 LK
2-CV-I	VALVE	10091400	CHECK VALVE	VOID - TO BE UPDATED	811022 VOID
2-CV-H	VALVE	111190310	INSTALL CHECK VALVE	VOID - WORK DONE ON ANOTHER MR	811120 VOID
1-CV-I	VALVE	111301340	CHECK VALVE HAS BODY TO BONNET LEAK	VOID	811203 VOID
2-CV-H	VALVE	110290942	REPLACE VALVE	REPLACED CV CHECK VALVE 2-CV-H	811205 LK
2-CV-I	VALVE	110290938	REPLACE VALVE	REPLACED CHECK VALVE	811205 LK
1-CV-I	VALVE	112071058	PLUG ON VALVE LEAKS	SEAL WELDED PLUGS	811207 BL
1-CV-I	VALVE	112061045	CHECK VALVE LEAKS	FIXED PLUG ON VALVE	811207 BL
1-CV-I	VALVE	112031010	REPLACE GASKET	REPLACED RING	811211 BL
2-CV-J	VALVE	110290941	REPLACE VALVE	REPLACED CHECK VALVE 2-CV-J	811215 LK
2-CV-J	VALVE	202230826	FURMANITE	COMPLETED MR FOR REPAIRS	820226 BL
2-CV-J	VALVE	203011630	REPAIR FURMANITE	INSTALLED NEW BONNET RING GASKET	820302 BL
2-CV-J	VALVE	202260813	REPAIR CAP	INSTALLED BONNET RING	820303 BL
2-CV-J	VALVE	205170805	WELD CHECK VALVE DISC SHAFT PLUG	SEAL WELDED PLUG	820520 BL
2-CV-J	VALVE	205070641	PLUGS ON BODY OF CHECK VALVE	VOID	820520 VOID
2-CV-I	VALVE	205161150	WELD DISC SHAFT PLUGS	SEAT WELDED PLUG	820522 BL
2-CV-H	VALVE	205161147	WELD DISC SHAFT PLUGS	SEAL WELDED PLUG	820522 BL
2-CV-H	VALVE	312071039	CHECK VALVE LEAKS THROUGH	LAPPED VALVE DISH TO SEAT	831214 LK
2-CV-I	VALVE	312071040	CHECK VALVE LEAKS THROUGH	CUT OUT SEAL WELD	831221 LK
2-CV-J	VALVE	312071041	CHECK VALVE LEAKS THROUGH	LAPPED SEATS	831221 LK
1-CV-H	VALVE	401011220	FURMANITE	PEENED PLUG IN BODY	840107 BL
1-CV-H	VALVE	312160902	LEAKS THROUGH	CLEANED VALVE & LAP SET	840107 LK
2-CV-H	VALVE	312301334	BODY TO BONNET LEAK	VOID - COMPLETED ON MR 312310920	840127 VOID

\* PMS - PREVENTIVE MAINTENANCE    BL - BOUNDARY LEAK    VOID - VOIDED    LK - UNDETECTED LEAKAGE FAILURE



Table B.1.e. (continued)

MARK NO.	COMPONENT	M. R. #	PROBLEM DESC	MODE/MECHANISM(if applicable) HISTORY SUMMARY	RTSVDT	CLASSIFICATION*
1-CV-H	VALVE	401180631	NO ADJUSTMENT LEFT ON PACKING GLAND	VOID - THIS VALVE IS AN AUX FD CK VALVE	840307	VOID
1-CV-H	VALVE	401031302	REPAIR TO ORIGINAL WELD PLUGS	WELDED PLUGS	840313	BL
2-CV-J	VALVE	403131437	OPEN & INSPECT VALVE	CUT OUT VALVE, SHIP TO CRANE FOR REPAIR	840406	LK
2-CV-I	VALVE	403131441	OPEN AND INSPECT VALVE	CUT OUT VALVE, SHIP TO CRANE FOR REPAIR	840406	LK
2-CV-H	VALVE	401031301	REPAIR TO ORIGINAL FURMANITED	SHIPPED VALVE TO CRANE FOR REPAIRS	840406	LK
1-CV-H	VALVE	404080900	CHECK VALVE LEAKS THROUGH	OVERHAULED CHECK VALVE	840509	LK
2-CV-H	VALVE	312310920	FURMANITE BODY TO BONNET LEAK	VOID - COMPLETED ON MR 2312371920	840521	VOID
1-CV-I	VALVE	406120857	CHECK VALVE LEAKS THROUGH	VOID - NO PROBLEM	840723	VOID
1-CV-I	VALVE	2385	OVERHAUL VALVE	DISASSEMBLED VALVE AND INSPECTED INTERNALS. LAP SEAT AND DISC GOT 100% BLUEING. REMOVED 2-PIN RETAINIG PLUGS. INSTALLED PIN, RETAINING PLUGS AND WELDED.	841210	LK

\* PMS - PREVENTIVE MAINTENANCE    BL - BOUNDARY LEAK    VOID - VOIDED    LK - UNDETECTED LEAKAGE FAILURE

Table B.1.f. MAINTENANCE RECORDS FOR THE AUXILIARY FEEDWATER SYSTEM 4-INCH CHECK VALVES

MARK NO.	COMPONENT	M. R. #	PROBLEM DESC	MODE/MECHANISM(if applicable) HISTORY SUMMARY	RTSVDT	CLASSIFICATION*
1-CV-C	VALVE	304291402	LEAKS BACK THROUGH	REPAIR VALVE	830504	LK/00
1-CV-B	VALVE	304291400	LEAKS BACK THROUGH	REBUILT VALVE	830525	LK/00
2-CV-C	VALVE	305040509	CHECK VALVE	LAPPED SEAT REPLACED NUTS	830926	LK/00
2-CV-C	VALVE	311181137	CHECK VALVE LEAKS BY	PERFORMED CLEANLINESS INSPECTION	831119	LK/00
2-CV-C	VALVE	311201310	2-CV-C IS LEAKING BY	INSPECTED VALVE INTERNALS	831120	LK/00
2-CV-C	VALVE	311202330	CHECK VALVE LEAKS BACK	VOID - COMPLETED ON MR 311201310	831121	VOID
2-CV-C	VALVE	401270925	RESEAT VALVE	LAPPED SEAT AND DISC	840128	LK/00
2-CV-C	VALVE	403070933	LEAKS THROUGH RESEAT	VALVE CHECKED 2-CV-C	840313	LK/00
2-CV-B	VALVE	403131354	OPEN AND INSPECT VALVE	NOTHING FOUND 100%	840408	PMS
2-CV-C	VALVE	01742	LEAKS THROUGH RESEAT	VOID--TO BE COMPLETED ON WO #01799.	841218	VOID
2-CV-C	VALVE	01799	OVERHAUL VLV.	DISASSEMBLE VALVE LAPPED SEAT AND DISC, HAVE 100% BLUEING.	841218	LK/00

\* PMS - PREVENTIVE MAINTENANCE    VOID - VOIDED    LK - UNDETECTED LEAKAGE FAILURE    00 - BACKFLOW FAILURE

Table B.1.g. MAINTENANCE RECORDS FOR THE AUXILIARY FEEDWATER SYSTEM 6-INCH CHECK VALVES

MARK NO.	COMPONENT	M. R. #	PROBLEM DESC	MODE/MECHANISM(if applicable) HISTORY SUMMARY	RTSVDT	CLASSIFICATION*
2-CV-D	VALVE	4141442	CHECK VALVE	VOID	800610	VOID
2-CV-F	VALVE	4141441	CHECK VALVE	VOID	800610	VOID
2-CV-E	VALVE	4141440	CHECK VALVE LEAKS	VOID	800610	VOID
2-CV-G	VALVE	4141443	CHECK VALVE	VOID	800610	VOID
2-CV-F	VALVE	203040635	REPAIR VALVE LEAK	VOID - TO BE WORKED ON 2112111242	821213	VOID
2-CV-A	VALVE	301131830	LEAKS BY SEAT	VOID - NOT A PROBLEM AT THIS TIME	830117	VOID
2-CV-A	VALVE	301131150	OVERHAUL LEAK THROUGH CHECK VALVE	OVERHAUL VALVE	830117	LK/00
2-CV-F	VALVE	304212311	LEAKS THRU	LAPPED SEAT + DISK	830426	LK
2-CV-G	VALVE	304212312	LEAKS THRU	LAPPED DISK + SEAT	830426	LK
1-CV-A	VALVE	304291401	LEAKS BACK THROUGH	REWORKED VALVE	830520	LK/00
2-CV-D	VALVE	301131002	OVERHAUL LEAKS THROUGH	LAPPED SEATS	830815	LK
2-CV-F	VALVE	301131004	OVERHAUL LEAKS THROUGH	GROUND SEAT AND DISCONNECTED	830926	LK
2-CV-E	VALVE	309062204	VALVE LEAKING	SEAL WELDED PLUGS TO VALVE BODY	831006	BL
2-CV-A	VALVE	311202358	VALVE LEAKING BACK	VOID - TO BE DONE ON MR 311201520	831121	VOID
2-CV-A	VALVE	311201520	CHECK VALVE LEAKING BACK THROUGH	DISASSEMBLED VALVE	831129	LK/00
2-CV-F	VALVE	312071055	CHECK VALVE LEAKS THROUGH	INSPECTED VALVE INTERNALS	831213	LK
2-CV-D	VALVE	312071100	CHECK VALVE LEAKS THROUGH	NO LEAKS FOUND	831214	PMS
2-CV-G	VALVE	312090840	INSPECT VALVE FOR LEAKAGE	REMOVED VALVE & BLUED TO 100%	831214	PMS
2-CV-D	VALVE	403271000	OPEN & INSPECT VALVE	OPENED VALVE FOR INSPECTION, FOUND	840406	LK
2-CV-D	VALVE	404031130	LEAKS THROUGH	REWORKED VALVE	840406	LK
2-CV-E	VALVE	403270840	OPEN AND INSPECT VALVE	HAD DISC MACHINED, LAPPED DISC	840406	LK
2-CV-G	VALVE	403131346	OPEN AND INSPECT VALVE	100% BLUE CHECK	840406	PMS
2-CV-F	VALVE	404072152	VALVE LEAKS THROUGH	INSPECTED VALVE AND LAPPED	840408	LK
2-CV-F	VALVE	404031540	LEAKS THROUGH	OVERHAUL INTERNALS	840408	LK
2-CV-F	VALVE	404070928	VALVE LEAKS THROUGH	RELAPPED & TESTED PRIOR TO ASSEMBLY	840408	LK
2-CV-F	VALVE	404081000	REMOVE BONNET & INSPECT	OPENED AND INSPECTED VALVE	840408	LK
2-CV-F	VALVE	404021320	VALVE LEAKS BY	MACHINED TEN FROM DISC 100%	840408	LK
2-CV-F	VALVE	403131342	OPEN AND INSPECT VALVE	100% BLUE CHECK GOOD	840408	PMS
2-CV-A	VALVE	403131349	OPEN AND INSPECT VALVE	100% BLUE CHECK CHANGED	840408	PMS
2-CV-E	VALVE	304212314	LEAKS THRU	VOID-COMPLETED ON WK ORDER 001222	840810	VOID
2-CV-E	VALVE	01222	OVERHAUL VLV.	DISASSEMBLE VALVE AND INSPECT INTERNALS LAP SEAT AND DISC AS NECESSARY TO GET 100% BLUEING	841114	LK
2-CV-F	VALVE	25925	-P,S- OVERHAUL VALVE	VOID NOT REQUIRED	861124	VOID

\* PMS - PREVENTIVE MAINTENANCE    BL - BOUNDARY LEAK    VOID - VOIDED    LK - UNDETECTED LEAKAGE FAILURE  
 OO - BACKFLOW FAILURE

B-45

Table B.1.g. (continued)

MARK NO.	COMPONENT	M. R. #	PROBLEM DESC	MODE/MECHANISM(if applicable) HISTORY SUMMARY	RTSVDT	CLASSIFICATION*
2-CV-D	VALVE	25924	-P,S- OVERHAUL VALVE	DISSASSEMBLED VALVE GROUND SEAT ON FLAPPER BLUED SEATING SURFACES. REASSEMBLED VALVE TORQUED TO 368 FR LB. SEAL WELD PLUG INSIDE OF VALVE.	861202	LK
2-CV-E	VALVE	30558	-P,S- INSPECT/REPAIR VALVE	REWORK VALVE/UNK TACK WELDS ON PIN PLUG TO BE GROUND OFF THEN REWELDED AFTER VALVE WORK COMPLETE. OPEN VALVE AND INSPECTED INTERNALS. FOUND 1/16-LEAKING THROUGH/NORMAL WEAR	870104	LK
1-CV-A	VALVE	49606	REPAIR LEAK	AS FOUND - CHECK VALVE SUPPOSEDLY LEAKING BY. WATER RUNNING OUT OF DRAIN VALVE BETWEEN PUMP AND CHECK VALVE. REMOVED CAP ON	870214	LK/00
1-CV-A	VALVE	49058	P-REPAIR CHECK VALVE	LEAK BY SEAT/WORN DISC DISASSEMBLED VALVE BLUED SEAT. SEAT LOOKED OK. DISC WORN OUT AND PITTED. LAPPED DISC BLUED 100%. REASSEMBLED VALVE.	870214	LK/00
1-CV-A	VALVE	53704	P-INVESTIGATE, REPAIR CHECK VALVE	LEAK/WEAR AS FOUND - VALVE SEAT CORRODED AND SLIGHTLY PITTED, WORK PERFORMED. REMOVED BONNET PIN AND DISK, CLEANED VALVE PIN AND BONNET.	870528	LK/00

\* PMS - PREVENTIVE MAINTENANCE    BL - BOUNDARY LEAK    VOID - VOIDED    LK - UNDETECTED LEAKAGE FAILURE  
 OO - BACKFLOW FAILURE

B-46

2-1

Table B.1.h. MAINTENANCE RECORDS FOR THE AUXILIARY FEEDWATER SYSTEM 1-INCH CHECK VALVES

MARK NO.	COMPONENT	M. R. #	PROBLEM DESC	MODE/MECHANISM(if applicable) HISTORY SUMMARY	RTSVDT	CLASSIFICATION*
1-FW-159	VALVE	910212300	LEAKS BY	VOID - NO PROBLEM AT THIS TIME	810429	VOID
1-FW-163	VALVE	910212340	LEAKS BACK BY	VOID - NO PROBLEM AT THIS TIME	810429	VOID
1-FW-159	VALVE	106180924	REPLACE HANDLE ON VALVE	REPLACED HANDLE WITH NUT	810621	MD
1-FW-144	VALVE	305012002	CHECK VALVE LEAK	REWORKED VALVE	830524	NFF
1-FW-174	VALVE	305012003	CHECK VALVE LEAK	REPAIR VALVE	830524	NFF
1-FW-144	VALVE	304291401	LEAKS BACK THROUGH	REBUILT VALVE	830525	NFF
1-FW-159	VALVE	304291400	LEAKS BACK THROUGH	REBUILT VALVE	830525	NFF
1-FW-144	VALVE	28174	OPEN AND INSPECT FOR BLOCKAGE	INSPECT/EWR DISASSEMBLED VALVE CLEANED, INSPECTED INTERNALS, BLUED SEAT, GOT 100% BLUE, REASSEMBLED VALVE TORQUED BOLTS TO 45 FT LBS NO BLOCKAGE	860221	PMS
1-FW-175	VALVE	32186	ADJUST PACKING	LEAK/ADJUST FOUND VALVE LEAKING, ADJUSTED 4 FLATS, LEAK STOPPED. ROOM FOR MORE ADJUSTMENT.	860320	BL
1-FW-144	VALVE	38576	INSPECT VALVE AS REQUIRED	OPENED VALVE, INSPECTED INTERNALS AND FOUND EVERYTHING SATISFACTORY. CLOSED OUT VALVE.	860722	PMS
1-FW-174	VALVE	49059	P-REPAIR VALVE	METAL BROKEN/PISTON AND SEAT AS FOUND 2/6/87 - VALVE SEATS BROKEN AWAY FROM PISTON, CUT OLD VALVE OUT OF SYSTEM, INSTALLED NEW VALVE AND CLEANED FOR NDE.	870219	NFF
*VOID - VOIDED		MD - MINOR DEFICIENCY	NFF - NON-FUNCTIONAL FAILURE			

B-47

Table B.1.i. MAINTENANCE RECORDS FOR THE AUXILIARY FEEDWATER SYSTEM 1-INCH CHECK VALVES

MARK NO.	COMPONENT	M. R. #	PROBLEM DESC	MODE/MECHANISM(if applicable) HISTORY SUMMARY	RTSVDT	CLASSIFICATION*
2-FW-130	VALVE	807102341	LEAKS THROUGH WHEN SHUT	CLEANED INTERNALS	780713	SL
1-FW-300	VALVE	808201850	LEAKS BY SEAT	VOID	781218	VOID
2-FW-134	VALVE	911141147	VALVE HANDLE BROKEN	REPLACED VALVE 2-CV-134	791129	MD
1-FW-91	VALVE	4170340	AUX FEEDWATER FLOW ORIFICE	REPAIRED PACKING LEAK	800420	BL
1-FW-304	VALVE	101160931	VALVE NOT OPERABLE, STEM BROKEN	DISASSEMBLE, MAKE NEW STEM	810119	MD
FE-202A	VALVE	202230830	UPPER ISOLATION VALVE LEAKING FURMANITE	COMPLETED MR FOR REPAIRS	820226	BL
FE-202B	VALVE	202230825	LOWER ISOLATION VALVE BLOWS FURMANITE	COMPLETED	820226	BL
	VALVE	104201040	REPAIR AUX FEEDWATER CHECK VALVE	REMOVED FURMANITE AND PLUGGED HOLES	820422	BL
2-FW-288	VALVE	112111243	HANDWHEEL MISSING	REPLACED MISSING HANDWHEEL	820522	MD
1-FW-30	VALVE	302131003	VALVE HAS PACKING LEAK	VOID COMP ON MR 302131112	830215	VOID
1-FW-31	VALVE	302131108	VALVE LEAKS BY WHEN SHUT	VOID WK DONE ON MR 302131002	830215	VOID
1-FW-61	VALVE	302141703	PACKING LEAK	VOID DONE ON MR 302131113	830223	VOID
1-FW-93	VALVE	302141125	PACKING LEAK	VOID DONE ON MR1302131106	830223	VOID
1-FW-60	VALVE	302141701	PACKING LEAK	ADDED ONE RING GARLOCK 98	830314	BL
1-FW-61	VALVE	302131113	VALVE LEAKS	COMPLETED	830314	SL
1-FW-30	VALVE	302131112	VALVE LEAKS	COMPLETED LAPPED + REPACKED	830315	SL
1-FW-31	VALVE	302131002	VALVE HAS PACKING LEAK	COMPLETED REPACKED + LAP	830315	SL
1-FW-92	VALVE	302131116	VALVE LEAKS BY WHEN SHUT	COMPLETED LAPPED + REPACKED	830315	SL
1-FW-59	VALVE	302141702	PACKING LEAK	ADDED PACKING	830317	BL
1-FW-62	VALVE	302131107	VALVE LEAKS	LAPPED GATE AND SEAT	830322	SL
1-FW-93	VALVE	302131106	VALVE LEAKS BY WHEN SHUT	LAPPED GATE AND SEAT	830322	SL
2-FW-130	VALVE	304220820	VALVE STEM BROKEN	VOID	830422	VOID
1-FW-92	VALVE	306261210	VALVE BODY TO BONNET LEAK	VOID WK TO DONE ON MR1306290246	830628	VOID
2-FW-130	VALVE	304211457	VLV NEEDS NEW STEM AND HANDWHEEL	REPLACED VALVES	830806	MD
2-FW-135	VALVE	304221001	VALVE LEAKS BY	REPLACED VALVE + NIPPLE CAP	830922	SL
2-FW-134	VALVE	312010741	HANDWHEEL SPINS FREE	REPLACED HANDWHEEL	831209	MD
1-FW-30	VALVE	312151155	VALVE CASING LEAK	VOID - TO BE DONE ON MR 312160916	831219	VOID
1-FW-29	VALVE	312160917	WON'T OPERATE	TOOK VALVE OFF BACK	831221	MD
1-FW-30	VALVE	312160916	HOLE IN VALVE - WON'T OPERATE	LUBED STEM	831221	MD
1-FW-185	VALVE	401040834	CLEAN AND GREASE VALVE STEM	CLEANED & LUBRICATED	840109	PMS
2-FW-185	VALVE	401040820	CLEAN AND GREASE VALVE STEM	CLEANED & LUBRICATED	840109	PMS
2-FW-134	VALVE	401191900	PACKING GLAND FOLLOWER BLEW OUT	INSTALLED 7 RINGS OF PACKING	840111	BL

\* PMS - PREVENTIVE MAINTENANCE    BL - BOUNDARY LEAK    VOID - VOIDED    MD - MINOR DEFICIENCY\*\*    SL - SEAT LEAKAGE

\*\* MANY OF THE MINOR DEFICIENCIES ARE MINOR BECAUSE THE FAILED COMPONENT HAS NO SIGNIFICANT SAFETY FUNCTION, FOR EXAMPLE THE FAILURE OF A STEM IN A 3/4 INCH DRAIN VALVE IS INSIGNIFICANT FROM A SAFETY STANDPOINT.

Table B.1.i. (continued)

MARK NO.	COMPONENT	M. R. #	PROBLEM DESC	MODE/MECHANISM(if applicable) HISTORY SUMMARY	RTSVDT CLASSIFICATION*
1-FW-61	VALVE	401100540	ONE HALF GPM PACKING LEAK	VOID - COMPLETED ON MR 1401082321	840130 VOID
1-FW-61	VALVE	401082321	BODY TO BONNET LEAK	REPLACED GASKET AND REPACKED	840313 BL
2-FW-134	VALVE	403311445	VALVE LEAKS BY	REPLACED VALVE & SECTION OF PIPING	840408 SL
2-FW-61	VALVE	308061204	REWORK VALVE	LAPPED IN VALVE	840408 SL
2-FW-62	VALVE	308061206	REPAIR VALVE	LAPPED IN DISK TO SEAT	840408 SL
1-FW-93	VALVE	404080903	VALVE BINDS UP, FREE UP	VOID - AS PER EWELL	840412 VOID
1-FW-286	VALVE	404110401	VALVE STEM SHEARED OFF	REPLACED VALVE BONNET ON	840417 MD
1-FW-61	VALVE	406092115	NEEDS TO BE FURMANITED	VOID - TO MR 1406180436	840625 VOID
1-FW-61	VALVE	406120856	BODY TO BONNET LEAK, FURMANITE	INJECTED BODY TO BONNET LEAK WITH	840627 BL
1-FW-130	VALVE	407222111	VALVE LEAKS THROUGH WHEN SHUT	REPLACED PIPE CAP	840730 BL
1-FW-299	VALVE	408011327	NEEDS 3/4 PIPE CAP	INSTALLED PIPE CAP	840810 BL
2-FW-130	VALVE	112111242	REPLACE HANDWHEEL	VOID - COMPLETED ON WO 001017	840810 VOID
1-FW-130	VALVE	407231629	REPLACE VALVE	VOID - COMPLETED ON WO 002925	840811 VOID
2-FW-130	VALVE	803250015	WELD LEAK	REPLACED CORRODED LINE	780329 BL
1-FW-61	VALVE	2474	RETURN VALVE TO ORIGINAL	DISASSEMBLED VALVE AND INSPECTED INTERNALS, REPAIR AS NECESSARY. INSTALLED NEW SEAL RING, STUDS, AND NUTS.	110284 PMS
1-FW-61	VALVE	10345	REPAIR B/B LEAK	LAPPED SEATING SURFACE. BLUE CHECKED VALVE 100% ONE SIDE, 90% OTHER. TORQUED BOLTS TO 167 FT/LBS. REPAIRED.	121584 BL
2-FW-93	VALVE	20212	2-FW-93 PACKING LEAKS	PACKED VALVE	060485 BL
2-FW-177	VALVE	27653	REPAIR LEAK AT HINGE PINS	REMOVED HINGE PIN PLUGS AND PUT THREAD COMPOUND ON PLUGS AND REINSTALLED.	020886 BL
2-FW-145	VALVE	28178	INSPECT FOR BLOCKAGE	PULL TO INSPECT/NO BLOCKAGE REMOVED BONNET FROM BODY FOUND NO BLOCKAGE IN LINE ON EITHER SIDE OF VALVE. BLUED SEATING SURFACE FOUND TO HAVE 100% CONTACT. CLEANED	022186 PMS

\* PMS - PREVENTIVE MAINTENANCE    BL - BOUNDARY LEAK    VOID - VOIDED    MD - MINOR DEFICIENCY\*\*    SL - SEAT LEAKAGE

\*\* MANY OF THE MINOR DEFICIENCIES ARE MINOR BECAUSE THE FAILED COMPONENT HAS NO SIGNIFICANT SAFETY FUNCTION, FOR EXAMPLE THE FAILURE OF A STEM IN A 3/4 INCH DRAIN VALVE IS INSIGNIFICANT FROM A SAFETY STANDPOINT.

Table B.1.i. (continued)

MARK NO.	COMPONENT	M. R. #	PROBLEM DESC	MODE/MECHANISM(if applicable) HISTORY SUMMARY	RTSVDT CLASSIFICATION*
2-FW-147	VALVE	28176	-I- INSPECT FOR BLOCKAGE	OPENED VALVE ACCORDING TO PROCEDURE, INSPECTED INTERNAL, BLUED SEATS.	022186 PMS
1-FW-62	VALVE	16733	P-REPLACE B/B GASKET	SEAT LEAKAGE/NORMAL WEAR DISASSEMBLED VALVE LAP SEAT AND GATE. 100% BLUEING. REPACKED AND REASSEMBLED.	052886 BL
1-FW-93	VALVE	35289	REPACK VALVE	PACKING LEAK/NORMAL WEAR REPACKED VALVE.	060986 BL
1-FW-62	VALVE	37511	REPAIR AS REQUIRED	PACKING LEAK/NORMAL WEAR TIGHTENED PACKING TO STOP LEAK.	062486 BL
1-FW-61	VALVE	37512	REPAIR AS REQUIRED	TIGHTENED PACKING TO STOP LEAK.	062486 BL
1-FW-145	VALVE	38600	INSPECT VALVE	OPENED VALVE FOR OPERATORS. INSPECTED AND FOUND SATISFACTORY. CLOSED OUT VALVE.	072286 PMS
1-FW-147	VALVE	38601	INSPECT VALVE INTERNALS	OPENED VALVE FOR OPERATORS INSPECTION, ALL WAS FOUND SATISFACTORY. CLOSED VALVE.	072286 PMS
2-FW-146	VALVE	28177	-P- INSPECT VALVE	VOID NOT REQUIRED PUMP OVERHAULED	110586 VOID
2-FW-168	VALVE	42338	REPAIR PACKING LEAK	VOID NOT REQUIRED.	111886 VOID
1-FW-155	VALVE	33987	ADJUST PACKING	VALVE PACKING GLAND ADJUSTED.	011187 PMS

\* PMS - PREVENTIVE MAINTENANCE    BL - BOUNDARY LEAK    VOID - VOIDED    MD - MINOR DEFICIENCY\*\*    SL - SEAT LEAKAGE

\*\* MANY OF THE MINOR DEFICIENCIES ARE MINOR BECAUSE THE FAILED COMPONENT HAS NO SIGNIFICANT SAFETY FUNCTION, FOR EXAMPLE THE FAILURE OF A STEM IN A 3/4 INCH DRAIN VALVE IS INSIGNIFICANT FROM A SAFETY STANDPOINT.



Table B.1.j. MAINTENANCE RECORDS FOR THE AUXILIARY FEEDWATER SYSTEM PIPING

MARK NO.	COMPONENT	M. R. #	PROBLEM DESC	HISTORY SUMMARY	RTSVDT	CLASSIFICATION*
6-WAPD-4	PIPING	908131523	SHIM PER ATTACHED SKETCH	COMPLETED AS PER ATTACHED SKETCH	790816	DC
6-WCMV-52	PIPING	908131543	SHIM PER ATTACHED SKETCH	COMPLETED AS PER ATTACHED SKETCH	790816	DC
6-WCMV-53	PIPING	908131544	SHIM PER ATTACHED SKETCH	COMPLETED AS PER ATTACHED SKETCH	790816	DC
6-WAPD-2	PIPING	908131039	DC 79-S32A INSTALL CONSTRAINT	INSTALLED CONSTRAINT	790817	DC
6-WCMU-6	PIPING	909171244	D/C 79-S32B INSTALL SNUBBER	INSTALLED SNUBBER MOUNT	790924	DC
6-WCMU-7	PIPING	909171224	D/C 79-S32B INSTALL SNUBBER	INSTALLED SNUBBER MOUNT	790924	DC
6-WCMU-6	PIPING	909171234	D/C 79-S32B INSTALL SNUBBER	COMPLETED AS PER ATTACHED SKETCH	790925	DC
6-WCMU-7	PIPING	909171237	DC 79-S32B INSTALL SNUBBER	COMPLETED AS PER ATTACHED SKETCH	790925	DC
1-FW-227	PIPING	909121627	PIPING BENT AND BROKEN 3A AUX FD PMP	REPLACED TUBING	790926	MD
8-WCMU-5	PIPING	909171317	D/C 79-S32B INSTALL SNUBBER	COMPLETED AS PER ATTACHED SKETCH	790927	DC
6-WCMU-5	PIPING	909171247	D/C 79-S32B INSTALL SNUBBER	COMPLETED AS PER ATTACHED SKETCH	791003	DC
6-WCMU-8	PIPING	2071346	DC 79-S32A REMOVE ROD HANGER	COMPLETED	800212	DC
6-WCMU-39	PIPING	3251246	DC 79-S32C REMOVE U-BOLT	COMPLETED	800402	DC
6-WAPD-50	PIPING	3211326	DC 79-S32C INSTALL STRAP	COMPLETED	800409	DC
6-WCMU-52	PIPING	3211346	DC 79-S32C INSTALL STRAP	INSTALLED CONSTRAINT AS PER SKETCH	800420	DC
6-WCMU-52	PIPING	3211347	DC 79-S32C INSTALL STRUT	COMPLETED	800425	DC
6-WAPD-50	PIPING	4260812	D/C 79-S32C SUPPORT MOD.	COMPLETED	800502	DC
6-WCMU-4	PIPING	4150734	D/C 79-S32C INSTALL SUPPORT	COMPLETED	800520	DC
6-WCMU-4	PIPING	4081056	DC 79-S32C INSTALL CONSTRAINT	COMPLETED	800520	DC
6-WCMU-4	PIPING	4081104	DC 79-S32C INSTALL CONSTRAINT	COMPLETED	800520	DC
6-WCMU-52	PIPING	5061346	D/C 79-S32C MODIFY SUPPORT	COMPLETED	800520	DC
6-WCMU-52	PIPING	5061347	D/C 79-S32C MODIFY SUPPORT	COMPLETED	800520	DC
6-WCMU-4	PIPING	4150733	D/C 79-S32C INSTALL SUPPORT	COMPLETED	800521	DC
6-WCMU-4	PIPING	4150735	D/C 79-S32C INSTALL SUPPORT	COMPLETED	800527	DC
6-WCMU-4	PIPING	4081106	DC 79-S32C INSTALL CONSTRAINT	COMPLETED	800527	DC
6-WCMU-4	PIPING	4150736	D/C 79-S32C INSTALL SUPPORT	COMPLETED	800527	DC
6-WCMU-52	PIPING	5061348	D/C 79-S32C INSTALL SUPPORT MOD.	COMPLETED	800527	DC
6-WAPD-150	PIPING	4241049	D/C 79-S32C SUPPORT MOD.	COMPLETED	800603	DC
6-WCMU-39	PIPING	7021422	D/C 79-S32C INSTALL SUPPORT MOD.	COMPLETED	800718	DC
6-WAPD-150	PIPING	7151315	D/C 79-S32C INSTALL SHIM	CLOSED	800728	DC
6-WAPD-150	PIPING	7151318	D/C 79-S32C INSTALL SHIM	COMPLETED	800728	DC
6-WAPD-50	PIPING	4230720	D/C 79-S32C SUPPORT MOD.	VOID - NO WORK PERFORMED	800902	DC
6-WCMU-104	PIPING	9080941	D/C 79-S56A INSTALL SUPPORT MOD	BASE PLATE TUBES, ANCHOR BOLTS, WELDS	800919	DC
6-WCMU-104	PIPING	9080940	D/C 79-S56A INSTALL SUPPORT MOD	BASE PLATE TUBES, ANCHOR BOLTS, WELDS	800919	DC
6-WCMU-104	PIPING	9091002	D/C 79-S56A INSTALL SUPPORT MOD	BOXED IN PIPE AND INSTALLED BASE PLATE	800924	DC

\* PMS - PREVENTIVE MAINTENANCE    VOID - VOIDED    MD - MINOR DEFICIENCY    DC - DESIGN CHANGE

Table B.1.j. (continued)

MARK NO.	COMPONENT	M. R. #	PROBLEM DESC	HISTORY SUMMARY	RTSVDT	CLASSIFICATION*
6-WCMU-104	PIPING	9091003	D/C 79-S56A INSTALL SUPPORT MOD	COMPLETE	800925	DC
6-WCMU-104	PIPING	9031004	DC79-S56C INSTALL SUPPORT	INSTALLED SUPPORT AS PER SKETCH	800925	DC
6-WAPD-50	PIPING	4221422	D/C 79-S32C INSTALL SUPPORT	COMPLETE	800926	DC
6-WCMU-104	PIPING	9031001	DC79-S56C INSTALL SUPPORT	BOXED IN PIPE AND INSTALLED BASEPLATE	800929	DC
6-WCMU-104	PIPING	9091001	D/C 79-S56A INSTALL SUPPORT MOD	NEW PIPE SUPPORT	801001	DC
6-WCMU-105	PIPING	9091000	D/C 79-S56A INSTALL SUPPORT MOD	INSTALLED NEW PIPE SUPPORT	801001	DC
6-WAPD-50	PIPING	4221424	D/C 79-S32C SUPPORT MOD.	INSTALLED PIPE CLAMP	801004	DC
6-WAPD-150	PIPING	4300909	D/C 79-S32C SUPPORT MOD.	INSTALLING ANGLE	801006	DC
6-WCMU-150	PIPING	9150939	D/C 79-S56A INSTALL SUPPORT MOD	INSTALLED TWO ANGLES WITH WELDS	801009	DC
6-WAPD-150	PIPING	4300901	D/C 79-S32C SUPPORT MOD.	INSTALL SUPPORT	801010	DC
6-WAPD-50	PIPING	4221423	D/C 79-S32C SUPPORT MOD.	INSTALL GUSSETS WITH WELDS	801015	DC
6-MCMU-104	PIPING	8260931	DC 79-S56A INSTALL SUPPORT	COMPLETED	801017	DC
6-WAPD-150	PIPING	9221304	D/C 79-S56A INSTALL SUPPORT MOD	BASE PLATES AND GUSSETS WITH WELDS	801021	DC
6-WAPD-50	PIPING	10020736	D/C 79-S32C REMOVE PORTION OF SUPPORT	COMPLETED AS PER REVISION REQUEST	801022	DC
6-WAPD-50	PIPING	5281301	D/C 79-S32C INSTALL SUPPORT MOD.	COMPLETED	801102	DC
6-WAPD-2	PIPING	9091041	D/C 79-S32A REMOVE ROD HANGER	REMOVED HANGER	801107	DC
6-WAPD-50	PIPING	9021406	DC79-S32C INSTALL SUPPORT	COMPLETE PER PROCEDURE	801109	DC
6-WAPD-152	PIPING	9260902	D/C 79-S56A INSTALL SUPPORT MOD	BASE PLATE TUBE STAINLESS STEEL BOX	801110	DC
6-WAPD-50	PIPING	9041301	D/C 79-S32A INSTALL SHIMS PER	COMPLETE	801111	DC
6-WAPD-50	PIPING	4260811	D/C 79-S32C SUPPORT MOD.	INSTALLED SUPPORT	801113	DC
6-WAPD-50	PIPING	9050715	D/C 79-S32A INSTALL SUPPORT MOD	COMPLETED	801117	DC
6-WAPD-150	PIPING	9300900	D/C 79-S56A INSTALL SUPPORT MOD	INSTALLED SUPPORT MOD	801126	DC
6-WCMU-150	PIPING	12030900	D/C 79-S56A INSTALL SUPPORT MOD	INSTALL ANGLE AND SHIM PLATE	801203	DC
6-WAPD	PIPING	9110847	D/C 79-S32A INSTALL SPRING HANGER	INSTALLED SPRING HANGER	801205	DC
6-WAPD-1	PIPING	9260816	D/C 79-S32A INSTALL VERTICAL/LATERAL	JOB COMPLETED 12-9-80	801216	DC
8-WCMU-5	PIPING	8251003	INSTALL SUPPORT	INSTALLED SUPPORT	801216	DC
6-WAPD-2	PIPING	9260817	D/C 79-S32A INSTALL NEW SPRING	INSTALLED SPRING CAN PER SKETCH	810202	DC
6-WCMU-4	PIPING	4241053	D/C 79-S32C INSTALL SUPPORT	COMPLETE	810312	DC
6-WAPD-150	PIPING	104130910	D/C 79-S56A INSTALL SUPPORT MOD	NEW SHIM	810421	DC
6-WAPD-50	PIPING	5011039	D/C 79-S32C INSTALL SUPPORT	VOID	810506	DC
6-WCMU-11	PIPING	9091040	D/C 79-S32C REMOVE ROD HANGER	VOID	810506	DC
6-WCMV-104-151	PIPING	105111259	D/C 79-S56A INSTALL SUPPORT MOD	COMPLETE	810602	DC
6-WCMV-139-151	PIPING	105111320	D/C 79-S56A INSTALL SUPPORT MOD	COMPLETE	810602	DC
6-WAPD-102	PIPING	106161203	D/C 79-S56A INSTALL SUPPORT MOD	COMPLETE	810618	DC
1-FW-229	PIPING	106091207	LEAK IN PIPING UPSTREAM 1-FW-229	TIGHTENED SWEDGELOCK FITTINGS	810927	MD

\* PMS - PREVENTIVE MAINTENANCE    VOID - VOIDED    MD - MINOR DEFICIENCY    DC - DESIGN CHANGE

Table B.1.j. (continued)

MARK NO.	COMPONENT	M. R. #	PROBLEM DESC	HISTORY SUMMARY	RTSVDT	CLASSIFICATION*
2-TDP	PIPING	111020616	INSTALL HEAT TRACING ON AUX FD LINE	INSTALLED HEAT TRACE, SATISFACTORY	820112	DC
FW-100ABC	PIPING	109271040	REPLACE GASKETS	VOID	820212	VOID
6-WCMU-52-151	PIPING	202101658	D/C 79-S32A INSTALL SHIM	ADDED SHIM	820215	DC
2-FW-PI-255AB&C	INSTR	203241104	FABRICATE MOUNTING PLATES	COMPLETED	820331	DC
PI-FW-155A,B,C	INSTR	203250402	FABRICATE AND INSTALL MOUNTING PLATE	FABRICATED MOUNTING BRACKETS	820331	DC
6-WAPD-50-601	PIPING	203180859	D/C 79-S32A PER SKETCH	TIGHTENED U-BOLT	820407	DC
6-WAPD-50-601	PIPING	203180849	D/C 79-S32A TIGHTEN U-BOLT	TIGHTENED U-BOLT	820407	DC
6-WAPD-150-601	PIPING	203080917	D/C 79-S32A PER SKETCH	DELETED SHIM	820419	DC
2-MOV-F	FLANGE	205070640	FLANGE LEAKS BY	WELD REPAIRED STEAM CUTS & HANDFITTED	820527	MD
6-WCM11-6-151	PIPING	202101615	D/C 79-S32A INSTALL SHIM PER SKETCH	ADDED SHIM	820729	DC
1-FW-FT-100A	PIPE	209021530	FLANGE LEAK ON FLOW TRANSMITTER	TIGHTENED UP THE ISOLATION	821013	MD
6-WAPD-150-601	PIPING	208110752	D/C 79-S32A INSTALL MODIFICATION	INSTALLED HANGER STRAP	821013	DC
FW-FT-100A	PIPING	210120841	FLANGE LEAK AT FLOW ELEMENT	INSTALLED 2 NEW FLEX	821015	MD
1-TDP	PIPING	211080901	CLEAN OUT DRAINS ON PUMP	CLEANED OUT FOUNDATION DRAINS	821115	PMS
2-TDP	PIPING	211080902	CLEAN OUT ALL DRAINS TO PUMP	CLEARED FOUNDATION DRAINS	821115	PMS
2-TDP	PIPING	212062200	FLANGE LEAK	SANDWICHED OLD GASKET	821207	MD
2-TDP	PIPING	211011412	10-YR ISI HYDROSTATIC TEST AUX FD PUMP	INSPECTION OF AUX FEED PUMP UNDER NO	821207	PMS
2-MDP-B	PIPING	211020108	10-YR ISI HYDRO TEST OF AUX FEED PUMP	INSPECTION OF AUX FEED PUMP	821207	PMS
1-TDP	PIPING	210300431	10 YEAR ISI HYDROSTATIC TEST	INSPECTION OF PIPING	821220	PMS
6-WCMU-8-151	PIPING	301101812	TEN-YEAR HDRO	FIRE MAIN INSPECTED, NO PROBLEM	830125	PMS
6-WUMU-108-151	PIPING	301251010	TEN-YEAR HYDRO	TEST PERFORMED	830125	PMS
6-WCMU-111-151	PIPING	301251347	10-YEAR INSPECTION	INSPECTION COMPLETED	830126	PMS
6-WCMU-111-151	PIPING	301251352	10-YEAR INSPECTION	INSPECTION COMPLETED	830126	PMS
6-WCMU-111-151	PIPING	301251338	PERFORM TEN-YEAR INSPECTION	INSPECTION COMPLETED	830126	PMS
6-MUMV-56-151	PIPING	301130947	TEN-YEAR HYDRO TEST	INSPECT PIPING, NO PROBLEM	830127	PMS
6-WCMU-11-151	PIPING	301130944	TEN-YEAR HYDRO TEST	PIPING INSPECTED, NO PROBLEM	830127	PMS
6-WCMU-54-151	PIPING	301241325	TEN-YR HYDRO	INSPECT PIPING, NO PROBLEM	830127	PMS
6-WAPD-50-601	PIPING	301112345	TEN-YEAR ISI HYDRO	INSPECTION COMPLETED	830216	PMS
1-MDP-A	PIPING	211020106	10-YR ISI HYDRO TEST OF AUX FD PUMP	WORK DONE UNDER STEAM GENERATOR HYDR	830228	PMS
1-FW-FE-100A	FLOW	302131005	FLANGES TO FLOW ELEMENT LEAK	REPLACED 2 FLEX GASKETS	830314	PMS
1-FW-FE-100A	ELEMENT	304052210	FLANGE LEAKS	REPLACED GASKET	830407	PMS
2-CN-TK-1	TANK	307271145	10 YEAR HYDRO	INSPECTION COMPLETE	830810	PMS
1-MDP-B	PIPING	211020107	10-YR ISI HYDRO TEST OF AUX FEED PUMP	INSPECTION COMPLETED	831019	PMS
2-FW-258	PIPE	310201059	PIPE NEEDS NEW INSULATION	REINSULATED PIPE	831104	PMS
2-MDP-A	LAGGING	311211202	OIL COOLER NEEDS LAGGING	REPLACED INSULATION	831202	MD

\* PMS - PREVENTIVE MAINTENANCE    VOID - VOIDED    MD - MINOR DEFICIENCY    DC - DESIGN CHANGE

Table B.1.j. (continued)

MARK NO.	COMPONENT	M. R. #	PROBLEM DESC	HISTORY SUMMARY	RTSVDT	CLASSIFICATION*
FW-FE-100A	PIPING	210130841	FLANGE LEAK	VOID - TO BE DONE ON MR 1312081531	831216	VOID
1-FW-FE-100A	ELEMENT	312081531	FURMANITE STEAM LEAK	SEAL WELDED PIPE PLUGS	831230	MD
1-FW-153	BRACKET	403081501	TUBING TRAY BROKEN OFF	REWELD SUPPORT	840313	MD
2-FW-89	PIPE	403171638	REMOVE RESTRAINT AS NECESSARY	REMOVED AND REPLACED RESTRAINT	840411	PMS
1-FW-FE-101A	ELEMENT	404131324	BLANK CAVITATING VENTURI	BLANKED VENTURI FOR HYDRO	840427	PMS
2-FW-PP-151	PIPE	406211048	REMOVE FURMANITE BOX, REPAIR	VOID - TO BE COMPLETED ON WO 002510	840816	VOID
* PMS - PREVENTIVE MAINTENANCE    VOID - VOIDED    MD - MINOR DEFICIENCY    DC - DESIGN CHANGE						

Table B.1.k. MAINTENANCE RECORDS FOR THE AUXILIARY FEEDWATER SYSTEM INSTRUMENTATION

MARK NO.	COMPONENT	M. R. #	PROBLEM DESC	HISTORY SUMMARY	RTSVDT	CLASSIFICATION*
1-FW-FE-100A	INSTR	10185490	CALIBRATE FLOW INDICATOR	CALIBRATED TRANSMITTER	780516	GAUGE
1-FW-FE-100B	INSTR	807061000	INDICATES 175 GPM WITH PUMP OFF	REPLACES TRANSMITTER	780917	GAUGE
1-FW-FE-100A	INSTR	5050755	CALIBRATE TRANSMITTER	CALIBRATED TRANSMITTERS	800506	GAUGE
1-FW-FE-100B	INSTR	5050756	CALIBRATE TRANSMITTER	CALIBRATED TRANSMITTER	800506	GAUGE
1-FW-FE-100C	INSTR	5050757	CALIBRATE TRANSMITTER	CALIBRATED TRANSMITTER	800506	GAUGE
2-FW-FE-200C	INSTR	4020800	REPLACE TRANSMITTER	REPLACED AND CALIBRATED TRANSMITTER	800625	GAUGE
1-FW-FE-100C	INSTR	105221547	FLOW INDICATOR DOES NOT WORK-STUCK	WRONG VALVE LINE-UP	810710	GAUGE
1-FW-FE-100A	INSTR	109300310	A STEAM GAUGE AUXILIARY FEED FLOW	CHECKED CALIBRATION, OPENED VALVE	811005	GAUGE
1-FW-FE-200B	INSTR	112100548	FLOW INDICATOR	REPLACED INDICATOR	820119	GAUGE
1-FW-FE-200C	INSTR	112100543	FLOW INDICATOR	REPLACED INDICATOR	820119	GAUGE
1-FW-FE-200ABC	INSTR	202021305	METERS BOUNCING	FILLED AND VENTED TRANSMITTER	820305	GAUGE
1-FW-FE-100C	INSTR	205191249	METER BOUNCING OFF ZERO	CALIBRATED TRANSMITTER	821015	GAUGE
1-FW-FE-200C	INSTR	212140636	FLANGE MISSING STUD	INSTALLED STUD & NUTS	821221	MD
1-FW-FE-100A	INSTR	211240135	CALIBRATE AS NECESSARY	CALIBRATED TRANSMITTER	830329	GAUGE
1-FW-FE-100B	TRANS	308110249	REPLACE TRANSMITTER	CHECKED LOOP AND XMTR	830811	GAUGE
1-FW-FE-200C	INSTR	309062154	ERRATIC INDICATION	TRANSMITTED, STABILIZED	830913	GAUGE
1-FW-FE-100B	INSTR	308170805	FEED FLOW SPIKES FI-FW-100B	REPLACED AND CALIBRATED TRANSMITTER	830930	GAUGE
2-FW-FE-200C	TRANSMIT	403191015	REDO THE ELECTRICAL SPLICES	VOID - NOT NEEDED	840320	VOID
2-FW-FE-200C	METER	402151134	METER INDICATES FLOW	PERFORMED TRANSMITTER CALIBRATION	840325	GAUGE
2-FW-FE-200B	METER	404011836	CHECK TRANSMITTER & METER	PERFORMED CALIBRATION 61	840406	GAUGE
2-FW-FE-200C	METER	404011840	CHECK TRANSMITTER & METER	PERFORMED CALIBRATION 62	840411	GAUGE

B-55

\* VOID - VOIDED MD - MINOR DEFICIENCY GAUGE - GAUGE REPLACEMENT OR CALIBRATION

**Table B.2**  
**Maintenance Records Broadly Classified as Failures**  
**for the Auxiliary Feedwater System**

Table B.2.a. MAINTENANCE RECORDS BROADLY CLASSIFIED AS FAILURES FOR THE AUXILIARY FEEDWATER SYSTEM TURBINE DRIVEN FEED PUMPS

MARK NO.	COMPONENT	M. R. #	PROBLEM DESC	MODE/MECHANISM(if applicable) HISTORY SUMMARY	RTSVDT	CLASSIFICATION*
1-TDP	PUMP	801010430	GROSS OIL-LOW DISCHARGE PRESSURE	RENEWED THRUST BEARING LININGS	780111	FR
1-TDP	PUMP	803030420	EXCESSIVE DISCHARGE PREE-PT15	REDUCED SPEED OF PUMP AT GOVERNOR	780303	FR
1-TDP	PUMP	901030450	GOV VALVE WILL NOT CONTROL PUMP SPEED	FIXED SATISFACTORY	790204	FR
1-TDP	TURB	810040500	VARIOUS REPAIRS	REPAIRED AND TESTED GOVERNOR TRIP VALVE	790420	FR
1-TDP	PUMP	912172125	OUTBOARD PUMP BEARING THROWING OIL	RENEWED THRUST BEARING	791223	FR
1-TDP	PUMP	1240708	OIL SEAL PACKING LEAK	RENEWED THRUST SHOE	800210	FR
1-TDP	INSTR	4131129	BROKEN CASE SWITCH	INSTALLED NEW SWITCH	800429	FR
2-TDP	PUMP	11170730	OVERSPEED TRIP VALVE TRIPS	STRAIGHTENED LINKAGE	801118	FR
2-TDP	PUMP	205081945	GOVERNOR SET AT 4060 RPM	RESET RPM TO 3880	820513	FR
1-TDP	PUMP	208132145	REPAIR OIL LEAK	CHANGED THRUSTED SHAFT COLLAR JOURNAL	820824	FR
2-TDP	GOVERNOR	212061305	REPAIR FEEDBACK ARM	REINSTALLED SETSCREW	821207	FR
2-TDP	PUMP	302111050	PUMP TRIPS	ADJUSTED OVERSPEED TRIP	830216	FR
2-TDP	PUMP	303101430	SET SCREW MISSING	ADJUSTED DAMPER	830314	FR
2-TDP	PUMP	303181232	OVERSPEED TRIP	PUT SPRING BACK ON HOOK	830321	FR
2-TDP	PUMP	304250400	OIL SEAL LEAKING	REPLACED BEARING AND THREAD SLOES	830429	FR
2-TDP	BEARING	306200726	REPLACE BEARING	REPLACED BEARING AND SHOES	830927	FR
2-TDP	PUMP	309271700	HIGH BEARING VIBRATIONS	ADJUSTED LINKAGE	831013	FR
1-TDP	PMP GOV	312311328	REPAIR GOVERNOR	INSTALLED NEW SEAT	840111	FR
2-TDP	SWITCH	402240947	PUMP WILL NOT CUT OFF IN AUTO	CHECKED SWITCH	840330	FR
1-TDP	PUMP	14061	MECHANICAL LINKAGE BROKEN	REINSERTED ROD AND CLOSED SOCKET ENDS AROUND BALL TIP.	850214	FR
2-TDP	PUMP	23379	PUMP INOPERABLE, REPAIR	REMOVED INBOARD AND OUTBOARD BEARING CAPS- FOUND BOTH JOURNAL BEARINGS IN GOOD CONDITION- OUTBOARD THRUST BEARING -THRUST SHOES- WIPED AND ROLLED OVER WITH BABBITT. ALIGNMENT BAD BEARINGS/INSUFF. OIL FLOW	850819	FR
1-TDP	PUMP	27017	P-REPAIR OIL LEAKS	REPLACED BEARINGS, THRUST BEARINGS, AND REPACKED PUMP.	860509	FR
1-TDP	PUMP	4170	INVESTIGATE PUMP BEARING LEAK	BROKEN SLINGER/THRUSTING REPLACED SLINGER, BEARINGS, WEAR RINGS, BALANCE	860820	FR
1-TDP	PUMP	40487	SPRING REPLACEMENT	GOVERNOR VALVE NOT OPEN ALL THE WAY, SUSPECT BAD SPRING. REMOVED OLD SPRING AND REPLACED WITH NEW SPRING. OPS DID AN OPERABILITY TEST AND GOVERNOR VALVE IS STILL NOT OPENING.	860907	FR

B-58

\* FR- POTENTIAL FAILURE TO RUN

Table B.2.a. (continued)

MARK NO.	COMPONENT	M. R. #	PROBLEM DESC	MODE/MECHANISM(if applicable) HISTORY SUMMARY	RTSVDT	CLASSIFICATION*
1-TDP	PUMP	41325	OPEN, INSPECT, REPAIR GOV VALVE	VALVE GOV LEAK THRU/STEAM CUT SEATS REMOVE LINKAGE AND VALVE FORM SYSTEM. FOUND BODY TO BE STEAM CUT ON SEATS. AS WE REMOVED BUSHING LINKAGE/IMPROPER SET	860927	FR
1-TDP	PUMP	40454	ADJUST GOVERNOR VALVE LINKAGE	DISCONNECTED LINKAGE L2 AND L1, REMOVED PIN FROM SHAFT L1, SET STEAM GOVERNOR VALVE, LOOSEMED FISHER REGULATING SPRING AND SET AT 3/8.	860930	FR
1-TDP	PUMP	40488	REPAIR OVERSPEED TRIP	VALVE CHECKED FOR FREEDOM OF MOVEMENT, FOUND TO BE STICKING APPROXIMATELY 50% IN THE CLOSED POSITION. VALVE DISASSEMBLY REVEALED HEAVY WEAR AND SOME STEAM CUTS TO GUIDE.	860930	FR
1-TDP	PUMP	40491	VALVE LINKAGE ADJUSTMENT	WE FOUND THE LINKAGE OUT OF ADJUSTMENT AND GOVERNOR LEVER HAD EXCESS WEAR. WE REMOVED THE OLD LINKAGE AND GOVERNOR LEVERS, REPLACING SAME WITH NEW LEVERS. THE NEW LEVERS HAD	860930	FR



Table B.2.b. MAINTENANCE RECORDS BROADLY CLASSIFIED AS FAILURES FOR THE AUXILIARY FEEDWATER SYSTEM MOTOR DRIVEN FEED PUMPS

MARK NO.	COMPONENT	M. R. #	PROBLEM DESC	MODE/MECHANISM(if applicable) HISTORY SUMMARY	RTSVDT	CLASSIFICATION*
2-MDP-B	PUMP	902050137	PUMP START NOT SATISFACTORY	TIME DELAY TESTED SATISFACTORY	790207	FS
2-MDP-A	PUMP	902050130	PUMP START NOT SATISFACTORY	TIME DELAY TESTED SATISFACTORY	790209	FS
2-MDP-A	PUMP	902131327	OIL COOLER END BELL CRACKED	REPAIRED COOLER	790324	FR
2-MDP-A	PMP MTR	902111545	MOTOR HEATER NOT WORKING	INSTALLED NEW HEATERS - TESTED SAT	790910	FS
2-MDP-B	HX	901081400	REPAIR HEATERS	INSTALLED NEW HEATERS - TESTED SAT	790910	FS
1-MDP-A	HX	912211400	TUBE LEAK	COMPLETED REPAIRS	791223	FR
2-MDP-B	PUMP	7222155	PUMP WILL NOT AUTO START	TESTED SATISFACTORY	800725	FS
1-MDP-A	PUMP	12270930	DAMAGE WAS CAUSED BY FREEZING	FIXED SPLIT CASING	810101	FR
1-MDP-A	HX	101130847	REPAIR BROKEN LUBE OIL COOLER	REPLACED GASKET AT HEAD	810114	FR
1-MDP-B	HT EXCH	101130846	HEAD-ON COOLER BROKEN	REMOVED HEAD, BRAZED TOGETHER	810114	FR
1-MDP-A	PUMP	101291401	LUBE OIL COOLER BROKEN	REPAIRED LUBE OIL COOLER HEADER	810201	FR
1-MDP-A	INSTR	105220735	PUMP STARTED IN 62	RESET AGASTATS	810522	FS
1-MDP-B	INSTR	105220737	PUMP STARTED IN 66	RESET AGASTATS	810522	FS
2-MDP-B	PUMP	4180731	NO OIL PRESSURE	PACKED STUDS CHECKED OIL PRESSURE	810616	FR
1-MDP-B	PUMP	111110340	BEARING VIBRATION PUMP	REPLACED INBOARD BEARING	820309	FR
1-MDP-A	MOTOR	203200519	MOTOR WAS SPRAYED WITH STEAM	PERFORMED PI CURVE	820320	FS
1-MDP-A	PUMP	203261300	DETERMINE FAILURE OF PUMP	BREAKER CLOSED SATISFACTORY	820330	FS
1-MDP-A	PUMP	210050528	FW LEAK UPSTREAM OF LUBE OIL COOLER	REPAIRED LEAK ON 3/4 PIPE	821014	FR
1-MDP-A	BREAKER	306072125	RELAY DROP ON A PHSE INST	MOTOR BRIDGED + MEGGERED	830611	FS
2-MDP-A	MOTO	309211500	REPAIR OR REPLACE MOTOR HEATER	REPLACED HEATER	831006	FS
2-MDP-A	RELAY	310060105	REPLACE 2-MDP-A RELAY	REPLACED RELAY COIL FAILED	831012	FS
2-MDP-B	PUMP	15531	2-MDP-B CHECK HEATERS	REMOVED BAD HEATER FROM MOTOR -NO STOCK ITEM- HEATER ORDERED 3/25/85. REPLACED DEFECTIVE HEATER, TEST SAT.	850712	FS
1-MDP-A	PUMP	39854	1-FW-M-3A MOTOR WET	PERFORM PI CURVE ON MOTOR WINDINGS, TESTED SATISFACTORY.	860826	FS
1-MDP-B	PUMP	39853	1-FW-M-3B MOTOR WET	PERFORMED PI CURVE ON MOTOR WINDING.	860826	FS
2-MDP-A	PUMP	51214	REPLACE/REPAIR LUBE OIL COOLER	LEAK/OIL IN WATER/WATER IN OIL. REMOVED LUBE OIL COOLER AND HYDRO WITH 100 PSI SERVICE AIR. NO LEAKAGE EVIDENT.	870331	FR

\* FR- FAILURE TO RUN FS - IYNCIPIENT FAILURE TO START

Table B.2.b. (continued)

MARK NO.	COMPONENT	M. R. #	PROBLEM DESC	MODE/MECHANISM(if applicable) HISTORY SUMMARY	RTSVDT	CLASSIFICATION*
1-MDP-B	PUMP	49509	P-REPLACE MOTOR HEATERS	HEATERS BAD/AGE, REPLACED HTRS MEGGERED 14 MEGOHMS AMPS .8 1.1 WORKED SAT. CHANGED OVERLOADS INSTALLED 1018L.	870522	FS
2-MDP-B	PUMP	52414	-P- REPLACE LO COOLER	LEAKING OIL/ INSTALL NEW COOLER. AS FOUND- COOLER LEAKING. WORK PERFORMED-INSTALLED NEW OIL COOLER. AS LEFT-TEST SAT.	870807	FR

\* FR- FAILURE TO RUN      FS - IYNCIPIENT FAILURE TO START

Table B.2.c. MAINTENANCE RECORDS BROADLY CLASSIFIED AS FAILURES FOR THE AUXILIARY FEEDWATER SYSTEM 3-INCH MOTOR OPERATED VALVES

MARK NO.	COMPONENT	M. R. #	PROBLEM DESC	MODE/MECHANISM(if applicable) HISTORY SUMMARY	RTSVDT CLASSIFICATION*
2-MOV-D	MOV	804061950	WON'T STAY CLOSED	ADJUSTED SWITCH	780407 PG
1-MOV-F	MOV	806022200	TORQUE SWITCH BAD	REPLACED TORQUE SWITCH	780605 PG
1-MOV-B	MOV	806302330	BREAKER WILL NOT RESET AND VALVE	REPAIRED - TESTED SATISFACTORY	780706 PG
2-MOV-A	MOV	810110135	DID NOT AUTO OPEN	CHECKED OUT CONTROL CIRCUIT - OK	781015 PG
1-MOV-E	MOV	1061910	MOTOR HOUSING SHATTERED	REPLACED WITH LIMTORQUE FROM MOV 251	800107 PG
1-MOV-E	MOV	1061825	DISCONNECT AND RECONNECT POWER	MOV REPLACED ON UNIT 1	800219 PG
2-MOV-E	MOV	1062046	REMOVE MOV FOR USE ON UNIT 1	COMPLETED	800323 PG
2-MOV-F	VALVE	4291230	DISASSEMBLE LIMITORQUE FOR INSPECTION	UNSTUCK	800509 PG
2-MOV-D	VALVE	4211429	VALVE OPEN WHEN SHOULD BE SHUT	VALVE OPERATES AS DESIGNED	800513 PG
2-MOV-D	MOV	5281601	MOV IS SHUT BREAKER IS OPEN	ADJUSTED SWITCH	800602 PG
2-MOV-B	MOV	8230940	TORQUE SWITCH PROBLEM	REPAIRED BROKEN WIRE	800826 PG
2-MOV-B	MOV	11011730	MOV WILL NOT OPERATE	REPAIRED LEADS, TEST SWITCH SATISFACTORY	801104 PG
1-MOV-F	MOV	906180842	LEAKS THRU	NEEDED TO BE WIRED UP	810325 PG
1-MOV-E	MOV	106100420	CHECK CONTROL CIRCUIT FOR POSS GROUND	COMPLETED AS PER EMP-C-MOV-63	810611 PG
1-MOV-A	MOV	103110840	VALVE STIFF	COMPLETED	810618 PG
1-MOV-F	MOV	110011750	MOV INDICATE CLOSED LOCALLY	COMPLETED - VALVE DOES NOT WORK SAT	811001 PG
2-MOV-C	VALVE	111121519	REPAIR GEAR BOX	RENEWED BEVEL GEAR	811207 PG
1-MOV-F	MOV	208140700	CHANGE LIMITORQUE	INSTALLED NEW LIMITORQUE	820814 PG
1-MOV-F	MOV	208120135	VALVE WILL NOT OPERATE BREAKER THERM	DISCONNECTED/RECONNECTED SATISFACTORY	820814 PG
1-MOV-F	MOV	210130602	VALVE WILL NOT FULLY CLOSE	DISCONNECTED/RECONNECTED MOV, SAT	821014 PG
1-MOV-F	MOV	210140101	MOV WILL NOT CLOSE	REMACHINED SEAT RING	821018 PG
2-MOV-BDF	CONTROL	212172011	WHEN LO-LO S/G LEVEL WAS RECEIVED	REWired BREAKERS AS	821218 PG
1-MOV-E	MOV	303100215	AGASTAT CONTACT IS STICKING	ADJUSTED MICROSWITCH	830313 PG
1-MOV-D	VALVE	304072030	VALVE OPENS BUT WILL NOT CLOSE	ADJUSTED LIMITS	830411 PG
1-MOV-C	MOV	304230521	VALVE MOTOR IS LOOSE	DISCONNECTED AND	830423 PG
2-MOV-F	VALVE	304240145	VLV WHEN CLOSED CAME BACK OPEN	VALVE CYCLED SAT	830424 PG
2-MOV-C	VALVE	304230659	DRIVE MECHANISM BROKEN	REPLACED DESTROYED MOV WITH NEW MOV	830426 PG
1-MOV-D	MOV	305111830	VALVE CLOSES	CYCLED VALVE	830520 PG
2-MOV-F	MOV	307050610	MOV WONT STAY CLOSED	CYCLED SAT	830819 PG
2-MOV-F	VALVE	401131605	VALVE OPENS	AGASTAT STICKING	840412 PG
1-MOV-D	VALVE	406140300	LIMITS NOT WORKING	REPLACED LIMIT SWITCH, GEAR WORN	840614 PG
1-MOV-D	VALVE	406191135	REPAIR/REPLACE GEAR ASSEMBLY	INSPECTED, FOUND LIMITORQUE SAT	840620 PG
1-MOV-D	VALVE	406190408	VALVE WON'T CLOSE OR OPEN	REPLACED LIMITS, DISCONNECTED	840620 PG
1-MOV-F	MOV	13893	1-MOV-F BREAKER TRIPPED	BRIDGED AND MEGGERED SATISFACTORY, CYCLED SEVERAL	850213 PG
2-MOV-B	MOV	02140	EXCESSIVE STROKE TIME	DISASSEMBLE VALVE AND INSPECT PARTS	850620 PG

\* PG - PLUGGING FAILURE

Table B.2.c. (continued)

MARK NO.	COMPONENT	M. R. #	PROBLEM DESC	MODE/MECHANISM(if applicable) HISTORY SUMMARY	RTSVDT CLASSIFICATION*
2-MOV-D	MOV	02382	INVESTIGATE STROKE TIME	DISASSEMBLED VALVE CLEAN AND INSPECTED INTERNALS REASSEMBLED VALVE WITH NEW BONNET GASKET, STEM, PLUG AND ROTATE REPACKED VALVE	850620 PG
2-MOV-F	MOV	02333	INVESTIGATE STROKE TIME	DISASSEMBLED VALVE REPLACED STEM, DISC TORQUE KEY, GASKET DISC WASHER-100 PERCENT BLUE CHECK REASSEMBLED VALVE	850620 PG
1-MOV-D	MOV	22962	1-MOV-D INVESTIGATE TRIP	WORKED WITH OPERATORS AND CYCLED VALVE; SATISFACTORY,NO PROBLEMS FOUND (OPEN 2.5 AMPS, CLOSED 2.5 AMPS).	850814 PG
2-MOV-A	MOV	20540	2-MOV-A WONT XFER CONTR	REPLACED COIL ON LATCHING RELAY OLD COIL BURNT UP	851029 PG
1-MOV-D	MOV	29885	INVESTIGATE/REPAIR MOV	RESET THERMO OVERLOADS, TURNED BREAKER ON AND VALVE AUTOMATICALLY WENT OPEN DRAWING 2.7 AMPS. DREW 2.7 ALL THE WAY CLOSED, THEN DREW 11.3 AMPS. WE THINK THE TORQUE SWITCH IS BROKEN.	860128 PG
1-MOV-D	MOV	29920	E-INVESTIGATE/REPAIR AS REQUIRED	AS FOUND - DISASSEMBLED LIMITORQUE, FOUND NO INTERNAL DAMAGE OF COMPONENTS. GREASE WAS VERY HARD, CLEANED ALL PARTS AND HOUSING,CHANGED OUT GREASE WITH EP-0, AND REASSEMBLED.	860131 PG
2-MOV-D	MOV	37688	2-MOV-D WILL NOT OPEN	FAILURE/VALVE WOULD NOT OPER. AUX. CONTACTS STUCK. CHECKED AND FOUND AUX. CONTACTS WERE STUCK OPERATED AND CHECKED SAT.	860715 PG
1-MOV-D	MOV	45967	INVESTIGATE/REPAIR AS NEEDED	ASSISTED OPERATORS IN OPENING VALVE FULLY FROM MCC. VALVE WENT FULL OPEN, FULL CLOSE WITH PROPER INDICATION. WORK PERFORMED ON WO 047506, 1/8/87.	861123 PG
1-MOV-E	MOV	49801	INVESTIGATE MALFUNCTION	VALVE WOULEN'T OPEN/AUXILIARY OPEN INTERLOCK STUCK ON OPENING CIRCUIT. REPLACED CONTACTOR 2/18/87, CHECKED SATISFACTORY. TIMES. FLA 2.4 ACTUAL, T1 2.4, T2 2.4, AND T3 2.4 OKAY.	870219 PG
2-MOV-C	MOV	46218	REPAIR VALVE	SPRING PACK DISASSEMBLED 12/30/86. S/N 347490. INSTALLED SPRING PACK ONLY. LEFT WITH MOVAT. WORK WAS PERFORMED BY MOVAT.	870225 PG

\* PG - PLUGGING FAILURE

Table B.2.d. MAINTENANCE RECORDS BROADLY CLASSIFIED AS FAILURES FOR THE AUXILIARY FEEDWATER SYSTEM 6-INCH MOTOR OPERATED VALVES

MARK NO.	COMPONENT	M. R. #	PROBLEM DESC	MODE/MECHANISM(if applicable) HISTORY SUMMARY	RTSVDT	CLASSIFICATION*
2-MOV-J	VALVE	810030726	WILL NOT OPERATE	MEG BRIDGED AND TESTED SATISFACTORY	781006	FC
2-MOV-J	MOV	812040631	THERMALS OUT WON'T OPEN	CLEANED, CHECKED MOTOR - TEST SAT	781204	FC
2-MOV-I	MOV	7231425	VALVE IS BINDING UP	REPAIRED VALVE	800801	FC
2-MOV-I	MOV	8050929	REPLACE LIMITORQUE	REPAIRED LIMITORQUE OPERATOR	800807	FC
2-MOV-J	MOV	8122234	VALVE WILL NOT COME FULL OPEN	NO PROBLEMS FOUND	800814	FC
2-MOV-J	VALVE	101131200	VALVE BINDS UNABLE TO CLOSE	CLEANED STEM THREADS	810120	FC
1-MOV-G	MOV	6120630	VALVE WILL NOT OPEN	COMPLETE	810423	FC
1-MOV-G	MOV	112120420	VALVE WILL NOT CYCLE	ADJUSTED LIMITS ON MOV-FW-160A, SAT	811212	FC
2-MOV-I	VALVE	304191635	VLV CYCLES HI AMPS ON MTR	ADJUSTED PACKING	830423	FC
2-MOV-I	VALVE	304231500	MOV-I WILL NOT OPEN	CLEANED TORQUE SWITCH	830423	FC
2-MOV-J	VALVE	304191637	VLV CYCLES HI AMPS ON MTR	ADJUSTED PACKING	830423	FC
2-MOV-J	VALVE	304231427	MOV-J WILL NOT OPEN	ADJUSTED TORQUE SWITCH	830423	FC
1-MOV-G	MOV	23350	INVESTIGATE/REPAIR	REMOVED MOUNTING BOLTS FROM TORQUE SWITCH AND	850823	FC
1-MOV-H	MOV	30387	MOV-H WILL NOT STROKE	CYCLED VALVE SEVERAL TIMES, OPENED T1 2.4, T2 2.8, AND T3 2.9; CLOSED T1 2.8, T2 2.6, T3 2.6, FOUND NO PROBLEM AT THIS TIME.	860211	FC
1-MOV-H	MOV	39300	1-MOV-H REPLACE BEARINGS	MOTOR HOIST/BEARINGS BAD DISCONNECTED MOTOR, REPLACED BEARINGS, RECONNECTED AND CYCLED SATISFACTORY. RECONNECTED MOTOR TEST, RAN SATISFACTORY.	860807	FC

\* FC - CROSS-CONNECTING FAILURE

Table B.2.e MAINTENANCE RECORDS BROADLY CLASSIFIED AS FAILURES FOR THE AUXILIARY FEEDWATER SYSTEM 3-INCH CHECK VALVES

MARK NO.	COMPONENT	M. R. #	PROBLEM DESC	MODE/MECHANISM(if applicable) HISTORY SUMMARY	RTSVDT CLASSIFICATION*
1-CV-J	VALVE	4102000	INSPECT VALVE	REPAIRED VALVE	800415 LK
1-CV-H	VALVE	4150916	INSPECT INTERNALS AND REPAIR	REPAIRED VALVE	800417 LK
1-CV-I	VALVE	4150915	INSPECT INTERNALS AND REPAIR	INSPECTED AND REPAIRED VALVE	800424 LK
1-CV-I	VALVE	109210813	OVERHAUL VALVE	COMPLETED AS ABOVE	810930 LK
1-CV-H	VALVE	109210811	OVERHAUL VALVE	COMPLETED AS ABOVE	810930 LK
1-CV-J	VALVE	109210815	OVERHAUL VALVE	COMPLETED AS ABOVE	810930 LK
2-CV-H	VALVE	110290942	REPLACE VALVE	REPLACED FW CHECK VALVE 2-CV-H	811205 LK
2-CV-I	VALVE	110290938	REPLACE VALVE	REPLACED CHECK VALVE	811205 LK
2-CV-J	VALVE	110290941	REPLACE VALVE	REPLACED CHECK VALVE 2-CV-J	811215 LK
2-CV-H	VALVE	312071039	CHECK VALVE LEAKS THROUGH	LAPPED VALVE DISH TO SEAT	831214 LK
2-CV-I	VALVE	312071040	CHECK VALVE LEAKS THROUGH	CUT OUT SEAL WELD	831221 LK
2-CV-J	VALVE	312071041	CHECK VALVE LEAKS THROUGH	LAPPED SEATS	831221 LK
1-CV-H	VALVE	312160902	LEAKS THROUGH	CLEANED VALVE & LAP SET	840107 LK
2-CV-J	VALVE	403131437	OPEN & INSPECT VALVE	CUT OUT VALVE, SHIP TO CRANE FOR REPAIR	840406 LK
2-CV-I	VALVE	403131441	OPEN AND INSPECT VALVE	CUT OUT VALVE, SHIP TO CRANE FOR REPAIR	840406 LK
2-CV-H	VALVE	401031301	REPAIR TO ORIGINAL FURMANITED	SHIPPED VALVE TO CRANE FOR REPAIRS	840406 LK
1-CV-H	VALVE	404080900	CHECK VALVE LEAKS THROUGH	OVERHAULED CHECK VALVE	840509 LK
1-CV-I	VALVE	2385	OVERHAUL VALVE	DISASSEMBLED VALVE AND INSPECTED INTERNALS. LAP  SEAT AND DISC GOT 100% BLUEING. REMOVED 2-PIN RETAINIG PLUGS. INSTALLED PIN, RETAINING PLUGS AND WELDED.	841210 LK

\* LK - UNDETECTED LEAKAGE FAILURE

B-65

Table B.2.f. MAINTENANCE RECORDS BROADLY CLASSIFIED AS FAILURES FOR THE AUXILIARY FEEDWATER SYSTEM 4-INCH CHECK VALVES

MARK NO.	COMPONENT	M. R. #	PROBLEM DESC	MODE/MECHANISM(if applicable) HISTORY SUMMARY	RTSVDT	CLASSIFICATION*
1-CV-C	VALVE	304291402	LEAKS BACK THROUGH	REPAIR VALVE	830504	LK/00
1-CV-B	VALVE	304291400	LEAKS BACK THROUGH	REBUILT VALVE	830525	LK/00
2-CV-C	VALVE	305040509	CHECK VALVE	LAPPED SEAT REPLACED NUTS	830926	LK/00
2-CV-C	VALVE	311181137	CHECK VALVE LEAKS BY	PERFORMED CLEANLINESS INSPECTION	831119	LK/00
2-CV-C	VALVE	311201310	2-CV-C IS LEAKING BY	INSPECTED VALVE INTERNALS	831120	LK/00
2-CV-C	VALVE	401270925	RESEAT VALVE	LAPPED SEAT AND DISC	840128	LK/00
2-CV-C	VALVE	403070933	LEAKS THROUGH RESEAT	VALVE CHECKED 2-CV-C	840313	LK/00
2-CV-C	VALVE	01799	OVERHAUL VLV.	DISASSEMBLE VALVE LAPPED SEAT AND DISC, HAVE 100% BLUEING.	841218	LK/00

\* LK - UNDETECTED LEAKAGE FAILURE      00 - BACKFLOW FAILURE

Table B.2.g. MAINTENANCE RECORDS BROADLY CLASSIFIED AS FAILURES FOR THE AUXILIARY FEEDWATER SYSTEM 6-INCH CHECK VALVES

MARK NO.	COMPONENT	M. R. #	PROBLEM DESC	MODE/MECHANISM(if applicable) HISTORY SUMMARY	RTSVDT	CLASSIFICATION*
2-CV-A	VALVE	301131150	OVERHAUL LEAK THROUGH CHECK VALVE	OVERHAUL VALVE	830117	LK/00
2-CV-F	VALVE	304212311	LEAKS THRU	LAPPED SEAT + DISK	830426	LK
2-CV-G	VALVE	304212312	LEAKS THRU	LAPPED DISK + SEAT	830426	LK
1-CV-A	VALVE	304291401	LEAKS BACK THROUGH	REWORKED VALVE	830520	LK/00
2-CV-D	VALVE	301131002	OVERHAUL LEAKS THROUGH	LAPPED SEATS	830815	LK
2-CV-F	VALVE	301131004	OVERHAUL LEAKS THROUGH	GROUND SEAT AND DISCONNECTED	830926	LK
2-CV-A	VALVE	311201520	CHECK VALVE LEAKING BACK THROUGH	DISASSEMBLED VALVE	831129	LK/00
2-CV-F	VALVE	312071055	CHECK VALVE LEAKS THROUGH	INSPECTED VALVE INTERNALS	831213	LK
2-CV-D	VALVE	403271000	OPEN & INSPECT VALVE	OPENED VALVE FOR INSPECTION, FOUND	840406	LK
2-CV-D	VALVE	404031130	LEAKS THROUGH	REWORKED VALVE	840406	LK
2-CV-E	VALVE	403270840	OPEN AND INSPECT VALVE	HAD DISC MACHINED, LAPPED DISC	840406	LK
2-CV-F	VALVE	404072152	VALVE LEAKS THROUGH	INSPECTED VALVE AND LAPPED	840408	LK
2-CV-F	VALVE	404031540	LEAKS THROUGH	OVERHAUL INTERNALS	840408	LK
2-CV-F	VALVE	404070928	VALVE LEAKS THROUGH	RELAPPED & TESTED PRIOR TO ASSEMBLY	840408	LK
2-CV-F	VALVE	404081000	REMOVE BONNET & INSPECT	OPENED AND INSPECTED VALVE	840408	LK
2-CV-F	VALVE	404021320	VALVE LEAKS BY	MACHINED TEN FROM DISC 100%	840408	LK
2-CV-E	VALVE	01222	OVERHAUL VLV.	DISASSEMBLE VALVE AND INSPECT INTERNALS LAP SEAT AND DISC AS NECESSARY TO GET 100% BLUEING	841114	LK
2-CV-D	VALVE	25924	-P,S- OVERHAUL VALVE	DISSASSEMBLED VALVE GROUND SEAT ON FLAPPER BLUED SEATING SURFACES. REASSEMBLED VALVE TORQUED TO 368 FR LB. SEAL WELD PLUG INSIDE OF VALVE.	861202	LK
2-CV-E	VALVE	30558	-P,S- INSPECT/REPAIR VALVE	REWORK VALVE/UNK TACK WELDS ON PIN PLUG TO BE GROUND OFF THEN REWELDED AFTER VALVE WORK COMPLETE. OPEN VALVE AND INSPECTED INTERNALS. FOUND 1/16-	870104	LK
1-CV-A	VALVE	49606	REPAIR LEAK	LEAKING THROUGH/NORMAL WEAR AS FOUND - CHECK VALVE SUPPOSEDLY LEAKING BY WATER RUNNING OUT OF DRAIN VALVE BETWEEN PUMP AND CHECK VALVE. REMOVED CAP ON	870214	LK/00
1-CV-A	VALVE	49058	P-REPAIR CHECK VALVE	LEAK BY SEAT/WORN DISC DISASSEMBLED VALVE BLUED SEAT. SEAT LOOKED OK. DISC WORN OUT AND PITTED. LAPPED DISC BLUED 100%. REASSEMBLED VALVE.	870214	LK/00
1-CV-A	VALVE	53704	P-INVESTIGATE, REPAIR CHECK VALVE	LEAK/WEAR AS FOUND - VALVE SEAT CORRODED AND SLIGHTLY PITTED, WORK PERFORMED. REMOVED BONNET PIN AND DISK, CLEANED VALVE PIN AND BONNET.	870528	LK/00

\* LK - UNDETECTED LEAKAGE FAILURE 00 - BACKFLOW FAILURE



**Table B.3**  
**Maintenance Records Broadly Classified**  
**as Failures for the Auxiliary Feedwater System,**  
**Rewritten Format**

Table B.3.a. MAINTENANCE RECORDS BROADLY CLASSIFIED AS FAILURES FOR THE AUXILIARY FEEDWATER SYSTEM TURBINE DRIVEN FEED PUMPS, REWRITTEN FORMAT

MARK NO.	COMPONENT	M. R. #	PROBLEM/REPAIR SUMMARY	RTSVDT	CLASS*
1-TDP	PUMP	801010430	THE LUBRICATING OIL PRESSURE FAILED LOW RESULTING IN BEARING DAMAGE, REPLACED THRUST BEARING LINING.	780111	FR
1-TDP	PUMP	803030420	THE PUMP DISCHARGE PRESSURE WAS HIGH, ADJUSTED THE GOVERNOR TO REDUCE THE PUMP SPEED AND THUS DISCHARGE PRESSURE.	780303	FR
1-TDP	PUMP	901030450	THE GOVERNOR VALVE WAS NOT CONTROLLING PUMP SPEED, GOVERNOR WAS REPAIRED IN SOME MANNER.	790204	FR
1-TDP	TURB	810040500	VARIOUS NON-SPECIFIED REPAIRS WERE MADE TO THE PUMP, THE PUMP WAS RETURNED TO SERVICE.	790420	FR
1-TDP	PUMP	912172125	THE OUTBOARD PUMP BEARING WAS THROWING ENOUGH OIL THAT IT WAS NECESSARY TO RENEW THE THRUST BEARING.	791223	FR
1-TDP	PUMP	1240708	AN OIL SEAL PACKING LEAK WAS LARGE ENOUGH THAT IT WAS NECESSARY TO RENEW THE THRUST BEARING SHOE.	800210	FR
1-TDP	INSTR	4131129	A BROKEN CASE SWITCH ASSOCIATED WITH THE DISCHARGE PRESSURE TRIP WAS FOUND AND REPLACED.	800429	FR
2-TDP	PUMP	11170730	DEFICIENCIES IN THE OVERSPEED TRIP VALVE CAUSED A PUMP TRIP, THE LINKAGE WAS STRAIGHTENED.	801118	FR
2-TDP	PUMP	205081945	THE GOVERNOR WAS CONTROLLING PUMP SPEED HIGH AT 4060 RPM, IT WAS RESET TO CONTROL AT AN RPM OF 3880.	820513	FR
1-TDP	PUMP	208132145	AN OIL LEAK WAS LARGE ENOUGH THAT IT WAS NECESSARY TO REPLACE SOME BEARINGS.	820824	FR
2-TDP	GOVERNOR	212061305	THE FEEDBACK ARM OF THE GOVERNOR WAS NOT WORKING CORRECTLY, A SETSCREW WAS INSTALLED.	821207	FR
2-TDP	PUMP	302111050	THE OVERSPEED TRIP CAUSED CAUSED INAPPROPRIATE PUMP TRIPS, THE OVERSPEED TRIP WAS CORRECTLY ADJUSTED.	830216	FR
2-TDP	PUMP	303101430	THE SET SCREW WAS FOUND MISSING FROM THE FEEDBACK ARM, IT WAS REPLACED AND THE ARM ADJUSTED CORRECTLY.	830314	FR
2-TDP	PUMP	303181232	FAILURE OF THE OVERSPEED TRIP SPRING TO STAY ENGAGED LED TO A PUMP TRIP, THE SPRING WAS REINSTALLED.	830321	FR
2-TDP	PUMP	304250400	AN OIL SEAL LEAK WAS LARGE ENOUGH THAT IT WAS NECESSARY TO REPLACE SOME BEARINGS AND THRUST SHOES.	830429	FR
2-TDP	BEARING	306200726	IT WAS NECESSARY, FOR SOME UNSPECIFIED REASON, TO REPLACE THE BEARINGS AND SHOES.	830927	FR

\* FR - FAILURE TO RUN

Table B.3.a. (continued)

MARK NO.	COMPONENT	M. R. #	PROBLEM/REPAIR SUMMARY	RTSVDT	CLASS*
2-TDP	PUMP	309271700	HIGH BEARING VIBRATIONS REQUIRED THE ADJUSTMENT OF THE PUMP TO MOTOR COUPLING.	831013	FR
1-TDP	PMP GOV	312311328	THE GOVERNOR WAS FOUND TO BE DAMAGED AND THE SEAT WAS REPLACED.	840111	FR
2-TDP	SWITCH	402240947	THE DISCHARGE PRESSURE SWITCH WAS NOT AUTOMATICALLY TRIPPING THE PUMP, THE SWITCH WAS REPAIRED.	840330	FR
1-TDP	PUMP	14061	THE MECHANICAL LINKAGE WAS FOUND TO BE BROKEN AND WAS REPAIRED.	850214	FR
2-TDP	PUMP	23379	PUMP WAS SAID TO BE INOPERABLE, OUTBOARD THRUST SHOE WAS FOUND WIPED, IT WAS REPLACED.	850819	FR
1-TDP	PUMP	27017	INSUFFICIENT OIL FLOW RESULTED IN BEARING DAMAGE, THE BEARINGS WERE REPLACED.	860509	FR
1-TDP	PUMP	4170	THE BEARINGS WERE DAMAGED AS A RESULT OF A BAD SLINGER, THE SLINGER AND BEARINGS WERE REPLACED.	860820	FR
1-TDP	PUMP	40487	THE GOVERNOR VALVE WOULD NOT OPEN, SPRING WAS REPLACED BUT THIS DID NOT HELP.	860907	FR
1-TDP	PUMP	41325	GOVERNOR WAS REMOVED AND OVERHAULED BECAUSE POOR OPERATION. (THIS EVENT SHOULD WAS COMBINED WITH RECORD 40487)	860927	FR
1-TDP	PUMP	40450	ADDITIONAL GOVERNOR WORK COMBINED WITH RECORD 40487.	860930	FR
1-TDP	PUMP	40488	ADDITIONAL GOVERNOR WORK COMBINED WITH RECORD 40487.	860930	FR
1-TDP	PUMP	40491	ADDITIONAL GOVERNOR WORK COMBINED WITH RECORD 40487.	860930	FR

\* FR - FAILURE TO RUN    FS - FAILURE TO START

Table B.3.b. MAINTENANCE RECORDS BROADLY CLASSIFIED AS FAILURES FOR THE AUXILIARY FEEDWATER SYSTEM MOTOR DRIVEN FEED PUMPS, REWRITTEN FORMAT

MARK NO.	COMPONENT	M. R. #	PROBLEM/REPAIR SUMMARY	RTSVDT	CLASS*
2-MDP-B	PUMP	902050137	THE PUMP DID NOT START QUICKLY ENOUGH, THE TIME DELAY CIRCUIT WAS ADJUSTED.	790207	FS
2-MDP-A	PUMP	902050130	THE PUMP DID NOT START QUICKLY ENOUGH, THE TIME DELAY CIRCUIT WAS ADJUSTED.	790209	FS
2-MDP-A	PUMP	902131327	THE OIL COOLER END BELL WAS FOUND TO BE CRACKED, IT WAS REPAIRED OR REPLACED.	790324	FR
2-MDP-A	PUMP MTR	902111545	THE MOTOR HEATER DID NOT WORK, A NEW HEATER WAS INSTALLED.	790910	FS
2-MDP-B	HX	901081400	THE MOTOR HEATER DID NOT WORK, A NEW HEATER WAS INSTALLED.	790910	FS
1-MDP-A	HX	912211400	TUBE LEAKS WERE FOUND IN THE HEAT EXCHANGER, THE LEAKING TUBES WERE PLUGGED OR REPLACED.	791223	FR
2-MDP-B	PUMP	7222155	THE PUMP WOULD NOT START AUTOMATICALLY, IT WAS SOMEHOW REPAIRED.	800725	FS
1-MDP-A	PUMP	12270930	THE PUMP CASING WAS SPLIT BY FREEZING, THE CASING WAS REPAIRED.	810101	FR
1-MDP-A	HX	101130847	THE LUBE OIL COOLER WAS FOUND TO BE LEAKING, THE HEAD GASKET WAS REPLACED.	810114	FR
1-MDP-B	HX	101130846	THE HEAD ON THE LUBE OIL COOLER WAS FOUND TO BE BROKEN, THE HEAD WAS REPAIRED BY BRAZING.	810114	FR
1-MDP-A	PUMP	101291401	THE LUBE OIL COOLER WAS FOUND TO BE BROKEN, THE COOLER WAS REPAIRED.	810201	FR
1-MDP-A	INSTR	105220735	THE PUMP STARTED TOO SLOWLY, THE AGASTATS WERE ADJUSTED.	810522	FS
1-MDP-B	INSTR	105220737	THE PUMP STARTED TOO SLOWLY, THE AGASTATS WERE ADJUSTED.	810522	FS
2-MDP-B	PUMP	4180731	SOME PART OF THE PUMP WAS FOUND TO HAVE NO LUBE OIL PRESSURE, THE "STUDS" WERE "PACKED" TO REPAIR THE PUMP, BEARINGS DAMAGE OR REPLACEMENT IS NOT MENTIONED.	810616	FR
1-MDP-B	PUMP	111110340	BEARING VIBRATION ON THE PUMP WAS EXCESSIVE, THE INBOARD BEARING WAS REPLACED.	820309	FR
1-MDP-A	MOTOR	203200519	THE MOTOR WAS SPRAYED WITH STEAM, PI CURVE DATA WAS COLLECTED AND APPARENTLY WAS SATISFACTORY.	820320	FS

\* FR - FAILURE TO RUN FS - FAILURE TO START

Table B.3.b. (continued)

MARK NO.	COMPONENT	M. R. #	PROBLEM/REPAIR SUMMARY	RTSVDT	CLASS*
1-MDP-A	PUMP	203261300	THE PUMP FAILED BECAUSE THE BREAKER TRIPPED OPEN, BREAKER SHUT SATISFACTORILY AFTER REPAIR. IT WAS ASSUMED THAT THE BREAKER TRIPPED ON PUMP START.	820330	FS
1-MDP-A	PUMP	210050528	A FEED WATER LEAK WAS FOUND UPSTREAM OF LUBE OIL COOLER, THE LEAKING 3/4" PIPE WAS REPAIRED.	821014	FR
1-MDP-A	BREAKER	306072125	A PHASE A RELAY DROPPED OUT, IT IS ASSUMED THAT THE PUMP TRIPPED SINCE A MEGGER WAS REQUIRED DURING REPAIR.	830611	FS
2-MDP-A	MOTOR	309211500	THE MOTOR HEATERS REQUIRED REPLACEMENT, THEY WERE REPLACED.	831006	FS
2-MDP-A	RELAY	310060105	A RELAY COIL FAILED IN THE START OR POWER CIRCUIT AND IT IS ASSUMED THAT THE PUMP FAILED TO START, THE RELAY WAS REPLACED.	831012	FS
2-MDP-B	PUMP	15531	THE MOTOR HEATER WAS BAD, IT WAS REPLACED.	850712	FS
1-MDP-A	PUMP	39854	THE MOTOR GOT WET, IT WAS DIERED AND CHECKED.	860826	FS
1-MDP-B	PUMP	39853	THE MOTOR GOT WET, IT WAS DIERED AND CHECKED.	860826	FS
2-MDP-A	PUMP	51214	LUBE OIL COOLER HAD A WATER TO OIL LEAK, IT WAS CHECKED OUT.	870331	FR
1-MDP-B	PUMP	49509	THE MOTOR HEATER WAS BAD, IT WAS REPLACED.	870522	FS
2-MDP-B	PUMP	52414	LUBE OIL COOLER WAS LEAKING, IT WAS REPLACED.	870807	FR

\* FR - FAILURE TO RUN      FS - FAILURE TO START

Table B.3.c. MAINTENANCE RECORDS BROADLY CLASSIFIED AS FAILURES FOR THE AUXILIARY FEEDWATER SYSTEM 3-INCH MOTOR OPERATED VALVES, REWRITTEN FORMAT

MARK NO.	COMPONENT	M. R. #	PROBLEM/REPAIR SUMMARY	RTSVDT	CLASS*
2-MOV-D	MOV	804061950	THE VALVE WOULD NOT STAY CLOSED, A SWITCH WAS ADJUSTED.	780407	PG
1-MOV-F	MOV	806022200	THE TORQUE SWITCH WAS FOUND TO BE BAD, IT WAS REPLACED.	780605	PG
1-MOV-B	MOV	806302330	THE SUPPLY BREAKER TRIPPED OPEN AND COULD NOT BE RESET, THE BREAKER WAS REPAIRED.	780706	PG
2-MOV-A	MOV	810110135	THE VALVE DID NOT OPEN AUTOMATICALLY, THE CONTROL CIRCUIT WAS REPAIRED.	781015	PG
1-MOV-E	MOV	1061910	THE MOTOR HOUSING FOR THE VALVE SHATTERED AND HAD TO BE REPLACED, IT WAS REPLACED WITH 251E MOTOR.	800107	PG
1-MOV-E	MOV	1061825	POWER WAS DISCONNECTED AND RECONNECTED TO FACILITATE MOTOR REPLACEMENT. COMBINE WITH 1061910.	800219	PG
2-MOV-E	MOV	1062046	THE MOTOR (AND MAYBE THE VALVE?) WAS REMOVED FOR USE ON UNIT 1. COMBINE WITH 1061910.	800323	PG
2-MOV-F	VALVE	4291230	THE MOTOR WAS DISASSEMBLED FOR INSPECTION AND FOUND TO BE STUCK, IT WAS REPAIRED.	800509	PG
2-MOV-D	VALVE	4211429	THE VALVE CONTROL CIRCUIT DID NOT OPERATE CORRECTLY AS THE VALVE WAS OPEN WHEN IT SHOULD HAVE BEEN SHUT, THE CONTROL CIRCUIT WAS REPAIRED.	800513	PG
2-MOV-D	MOV	5281601	THE SUPPLY BREAKER TRIPPED OPEN APPARENTLY ON OVERLOAD, A (TORQUE?) SWITCH WAS ADJUSTED TO FIX THE MOV.	800602	PG
2-MOV-B	MOV	8230940	A BROKEN WIRE WAS FOUND IN THE TORQUE SWITCH CIRCUIT, THE WIRE WAS REPAIRED.	800826	PG
2-MOV-B	MOV	11011730	THE MOV WOULD NOT OPERATE AND BAD LEADS WERE FOUND, THE LEADS WERE REPAIRED.	801104	PG
1-MOV-F	MOV	906180842	THE VALVE WAS LEAKING THROUGH DUE TO IMPROPER WIRING, THE CIRCUIT WAS REWIRED.	810325	PG
1-MOV-E	MOV	106100420	THE CONTROL CIRCUIT WAS CHECKED FOR A SUSPECTED GROUND, THE RESULTS ARE NOT INCLUDED IN THE SUMMARY.	810611	PG
1-MOV-A	MOV	103110840	THE VALVE WAS FOUND TO BE STIFF IN ITS OPERATION, IT WAS REPAIRED SOMEHOW.	810618	PG
1-MOV-F	MOV	110011750	THE MOV INDICATED CLOSED LOCALLY, THE VALVE WAS FOUND NOT TO OPERATE SATISFACTORILY.	811001	PG
2-MOV-C	VALVE	111121519	THE BEVEL GEAR IN THE OPERATOR WAS WORN AND HAD TO BE REPLACED.	811207	PG

\* PG - PLUGGING FAILURE

Table B.3.c. (continued)

MARK NO.	COMPONENT	M. R. #	PROBLEM/REPAIR SUMMARY	RTSVDT	CLASS*
1-MOV-F	MOV	208140700	THE OPERATOR WAS REPLACED.	820814	PG
1-MOV-F	MOV	208120135	THE VALVE WOULD NOT OPERATE AND CAUSED THE BREAKER TO TRIP ON THERMAL OVERLOAD. COMBINE WITH RECORD 208140700.	820814	PG
1-MOV-F	MOV	210130602	THE VALVE WOULD NOT FULLY CLOSE. COMBINE WITH RECORD 210140101.	821014	PG
1-MOV-F	MOV	210140101	THE VALVE WOULD NOT CLOSE, THE SEAT RING WAS MACHINED TO ALLOW CLOSURE.	821018	PG
2-MOV-BDF	CONTROL	212172011	ALL THREE VALVES OPERATED INCORRECTLY UPON RECEIVING A LO-LO S/G LEVEL SINGLE, THE SUPPLY BREAKERS WERE REWIRED TO REPAIR THE VALVES.	821218	PG
1-MOV-E	MOV	303100215	THE AGASTAT CONTACT WAS STICKING, IT WAS ADJUSTED.	830313	PG
1-MOV-D	VALVE	304072030	VALVE OPENED BUT WOULD NOT CLOSE INDICATING A CONTROL CIRCUIT PROBLEM, THE LIMITS WERE ADJUSTED.	830411	PG
1-MOV-C	MOV	304230521	THE VALVE MOTOR WAS FOUND TO BE LOOSE, IT WAS REPAIRED.	830423	PG
2-MOV-F	VALVE	304240145	THE VALVE CAME BACK OPENED WHEN IT WAS CLOSED INDICATING A CONTROL CIRCUIT PROBLEM, IT IS NOT APPARENT HOW THE VALVE WAS REPAIRED OR EVEN IF IT WAS REPAIRED.	830424	PG
2-MOV-C	VALVE	304230659	THE DRIVE MECHANISM WAS FOUND TO BE BROKEN, THE OPERATOR WAS REPLACED.	830426	PG
1-MOV-D	MOV	305111830	THE VALVE CLOSED APPARENTLY WHEN IT SHOULD NOT HAVE, IT IS NOT APPARENT FROM THE SUMMARY HOW THE VALVE WAS REPAIRED.	830520	PG
2-MOV-F	MOV	307050610	THE VALVE WOULD NOT STAY CLOSED INDICATING A CONTROL CIRCUIT PROBLEM, IT IS NOT APPARENT FROM THE SUMMARY HOW THE VALVE WAS REPAIRED.	830819	PG

\* PG - PLUGGING FAILURE

Table B.3.c. (continued)

MARK NO.	COMPONENT	M. R. #	PROBLEM/REPAIR SUMMARY	RTSVDT	CLASS*
2-MOV-F	VALVE	401131605	THE VALVE OPENED WHEN IT SHOULD NOT HAVE INDICATING A CONTROL CIRCUIT PROBLEM, THE AGASTAT WAS FOUND TO BE STICKING AND WAS REPAIRED.	840412	PG
1-MOV-D	VALVE	406140300	LIMIT SWITCH GEAR WAS WORN AND WAS REPLACED, COMBINED WITH RECORD 406190408.	840614	PG
1-MOV-D	VALVE	406191135	THE GEAR ASSEMBLY WAS REPLACED, COMBINED WITH RECORDS 406190408.	840620	PG
1-MOV-D	VALVE	406190408	THE VALVE WOULD NOT CLOSE OR OPEN, THE LIMITS WERE REPLACED.	840620	PG
1-MOV-F	MOV	13893	THE SUPPLY BREAKER TRIPPED, IT WAS CHECKED.	850213	PG
2-MOV-B	MOV	02140	THE VALVE WAS REPAIRED DUE TO EXCESSIVE STROKE TIME.	850620	PG
2-MOV-D	MOV	02382	THE VALVE WAS REPAIRED DUE TO EXCESSIVE STROKE TIME.	850620	PG
2-MOV-F	MOV	02333	THE VALVE WAS REPAIRED DUE TO EXCESSIVE STROKE TIME.	850620	PG
1-MOV-D	MOV	22962	THE SUPPLY BREAKER TRIPPED, IT WAS CHECKED.	850814	PG
2-MOV-A	MOV	20540	COIL IN LATCHING RELAY FAILED, IT WAS REPLACED.	851029	PG
1-MOV-D	MOV	29885	BREAKER TRIPPED ON THERMAL OVERLOAD, OVERLOADS RESET, NO FURTHER FAILURES.	860128	PG
1-MOV-D	MOV	29920	VALVE MALFUNCTION, RECORD UNCLEAR.	860131	PG
2-MOV-D	MOV	37688	VALVE DID NOT OPERATE BECAUSE AUXILIARY CONTACTS WERE STUCK, CONTACTS REPAIRED.	860715	PG
1-MOV-D	MOV	45967	VALVE MALFUNCTION, RECORD UNCLEAR.	861123	PG
1-MOV-E	MOV	29920	VALVE DID NOT OPEN DUE TO A STUCK INTERLOCK IN OPENING CIRCUIT. CONTACTOR REPLACED.	870219	PG
1-MOV-C	MOV	46218	SPRING PACK HAD TO BE REPAIRED, APPARENTLY THE VALVE WOULD NOT WORK.	870225	PG

\* PG - PLUGGING FAILURE



Table B.3.d. MAINTENANCE RECORDS BROADLY CLASSIFIED AS FAILURES FOR THE AUXILIARY FEEDWATER SYSTEM 6-INCH MOTOR OPERATED VALVES, REWRITTEN FORMAT

MARK NO.	COMPONENT	M. R. #	PROBLEM/REPAIR SUMMARY	RTSVDT	CLASS*
2-MOV-J	VALVE	810030726	THE VALVE WOULD NOT OPERATE, UNSPECIFIED REPAIRS WERE MADE AND THE VALVE WAS TESTED.	871006	FC
2-MOV-J	MOV	812040631	THE SUPPLY BREAKER TRIPPED ON THERMAL OVERLOAD, THE VALVE WAS CLEANED AND THEN TESTED.	871204	FC
2-MOV-I	MOV	7231425	THE VALVE WAS BINDING UP, UNSPECIFIED REPAIRS WERE MADE. COMBINE WITH 8050929.	800801	FC
2-MOV-I	MOV	8050929	THE LIMITORQUE OPERATOR WAS REPLACED OR REPAIRED.	800807	FC
2-MOV-J	MOV	8122234	THE VALVE WOULD NOT COME FULLY OPEN, IT WAS CHECKED AND NO PROBLEMS WERE FOUND.	800814	FC
2-MOV-J	VALVE	101131200	THE VALVE WAS BINDING AND WOULD NOT CLOSE, THE STEM THREADS WERE CLEANED.	810120	FC
1-MOV-G	MOV	6120630	THE VALVE WOULD NOT OPEN, UNSPECIFIED REPAIRS WERE MADE.	810423	FC
1-MOV-G	MOV	112120420	THE VALVE WOULD NOT CYCLE, THE LIMITS WERE ADJUSTED.	811212	FC
2-MOV-I	VALVE	304191635	THE MOTOR WAS DRAWING HIGH CURRENT DURING VALVE CYCLING, THE PACKING WAS ADJUSTED.	830423	FC
2-MOV-I	VALVE	304231500	THE VALVE WOULD NOT OPEN, THE TORQUE SWITCH WAS CLEANED. COMBINE WITH 3014191635.	830423	FC
2-MOV-J	VALVE	304191637	THE MOTOR WAS DRAWING HIGH CURRENT DURING VALVE CYCLING, THE PACKING WAS ADJUSTED.	830423	FC
2-MOV-J	VALVE	304231427	THE VALVE WOULD NOT OPEN, THE TORQUE SWITCH WAS ADJUSTED. COMBINE WITH 3014191637.	830423	FC
1-MOV-G	MOV	23350	REPIARED THE TORQUE SWITCH.	850823	FC
1-MOV-H	MOV	30387	VALVE WOULD NOT STROKE, IT WAS CHECKED.	860211	FC
1-MOV-H	MOV	39300	IT WAS NECESSARY TO REPLACE THE VALVE BEARINGS.	860807	FC

\* FC - CROSS-CONNECTING FAILURE

Table B.3.e. MAINTENANCE RECORDS BROADLY CLASSIFIED AS FAILURES FOR THE AUXILIARY FEEDWATER SYSTEM 3-INCH CHECK VALVES, REWRITTEN FORMAT

MARK NO.	COMPONENT	M. R. #	PROBLEM/REPAIR SUMMARY	RTSVDT	CLASS*
1-CV-J	VALVE	4102000	THE WAS INSPECTED AND UNSPECIFIED REPAIRS WERE PERFORMED.	800415	LK
1-CV-H	VALVE	4150916	THE WAS INSPECTED AND UNSPECIFIED REPAIRS WERE PERFORMED.	800417	LK
1-CV-I	VALVE	4150915	THE WAS INSPECTED AND UNSPECIFIED REPAIRS WERE PERFORMED.	800424	LK
1-CV-I	VALVE	109210813	THE VALVE WAS OVERHAULED FOR SOME UNSPECIFIED REASON.	810930	LK
1-CV-H	VALVE	109210811	THE VALVE WAS OVERHAULED FOR SOME UNSPECIFIED REASON.	810930	LK
1-CV-J	VALVE	109210815	THE VALVE WAS OVERHAULED FOR SOME UNSPECIFIED REASON.	810930	LK
2-CV-H	VALVE	110290942	THE VALVE WAS REPLACED FOR SOME UNSPECIFIED REASON.	811205	LK
2-CV-I	VALVE	110290938	THE VALVE WAS REPLACED FOR SOME UNSPECIFIED REASON. IT HAD BEEN FURMANITED PREVIOUSLY.	811205	LK
2-CV-J	VALVE	110290941	THE VALVE WAS REPLACED FOR SOME UNSPECIFIED REASON.	811215	LK
2-CV-H	VALVE	312071039	THE CHECK VALVE SEAT WAS LEAKING, THE SEAT WAS REPAIRED.	831214	LK
2-CV-I	VALVE	312071040	THE CHECK VALVE SEAT WAS LEAKING, THE SEAT WAS REPAIRED.	831221	LK
2-CV-J	VALVE	312071041	THE CHECK VALVE SEAT WAS LEAKING, THE SEAT WAS REPAIRED.	831221	LK
1-CV-H	VALVE	312160902	THE CHECK VALVE SEAT WAS LEAKING, THE SEAT WAS REPAIRED.	840107	LK
2-CV-J	VALVE	403131437	THE VALVE WAS INSPECTED FOR SOME REASON, IT WAS CUT OUT AND SENT TO CRANE FOR REPAIR. IT HAD BEEN FURMANITED SINCE IT WAS LAST REPLACED.	840406	LK
2-CV-I	VALVE	403131441	THE VALVE WAS INSPECTED FOR SOME REASON, IT WAS CUT OUT AND SENT TO CRANE FOR REPAIR.	840406	LK

\* LK - UNDETECTED LEAKAGE FAILURE

Table B.3.e. (continued)

MARK NO.	COMPONENT	M. R. #	PROBLEM/REPAIR SUMMARY	RTSVDT CLASS*
2-CV-H	VALVE	401031301	THE CHECK VALVE WAS SENT TO CRANE TO REPAIR IT TO ORIGINAL CONDITION FOLLOWING USE OF FURMANITE.	840406 LK
1-CV-H	VALVE	404080900	THE CHECK VALVE SEAT WAS LEAKING, THE SEAT WAS REPAIRED.	840509 LK
1-CV-I	VALVE	2385	THE CHECK VALVE WAS OVERHAULED, IT WAS ASSUMED TO BE BECAUSE OF A LEAK.	841210 LK

\* LK - UNDETECTED LEAKAGE FAILURE

Table B.3.f. MAINTENANCE RECORDS BROADLY CLASSIFIED AS FAILURES FOR THE AUXILIARY FEEDWATER SYSTEM 4-INCH CHECK VALVES, REWRITTEN FORMAT

MARK NO.	COMPONENT	M. R. #	PROBLEM/REPAIR SUMMARY	RTSVDT	CLASS*
1-CV-C	VALVE	304291402	THE CHECK VALVE SEAT WAS LEAKING, THE SEAT WAS REPAIRED.	830504	LK/00
1-CV-B	VALVE	304291400	THE CHECK VALVE SEAT WAS LEAKING, THE SEAT WAS REPAIRED.	830525	LK/00
2-CV-C	VALVE	305040509	THE CHECK VALVE SEAT WAS LEAKING, THE SEAT WAS REPAIRED.	830926	LK/00
2-CV-C	VALVE	311181137	THE CHECK VALVE SEAT WAS LEAKING, THE SEAT WAS INSPECTED.	831119	LK/00
2-CV-C	VALVE	311201310	THE CHECK VALVE SEAT WAS LEAKING, THE SEAT WAS INSPECTED. COMBINE WITH 311181137.	831120	LK/00
2-CV-C	VALVE	401270925	THE CHECK VALVE SEAT WAS LEAKING, THE SEAT WAS REPAIRED.	840128	LK/00
2-CV-C	VALVE	403070933	THE CHECK VALVE SEAT WAS LEAKING, THE VALVE WAS CHECKED.	840313	LK/00
2-CV-C	VALVE	1799	THE CHECK VALVE SEAT WAS LAPPED, IT WAS ASSUMED TO HAVE BEEN LEAKING.	841218	LK/00

\* LK - INCIPIENT UNDETECTED LEAKAGE FAILURE    OO - BACKFLOW FAILURE

Table B.3.g. MAINTENANCE RECORDS BROADLY CLASSIFIED AS FAILURES FOR THE AUXILIARY FEEDWATER SYSTEM 6-INCH CHECK VALVES, REWRITTEN FORMAT

MARK NO.	COMPONENT	M. R. #	PROBLEM/REPAIR SUMMARY	RTSVDT	CLASS*
2-CV-A	VALVE	301131150	THE CHECK VALVE SEAT WAS LEAKING, THE SEAT WAS REPAIRED.	830117	LK/00
2-CV-F	VALVE	304212311	THE CHECK VALVE SEAT WAS LEAKING, THE SEAT WAS REPAIRED.	830426	LK
2-CV-G	VALVE	304212312	THE CHECK VALVE SEAT WAS LEAKING, THE SEAT WAS REPAIRED.	830426	LK
1-CV-A	VALVE	304291401	THE CHECK VALVE SEAT WAS LEAKING, THE SEAT WAS REPAIRED.	830520	LK/00
2-CV-D	VALVE	301131002	THE CHECK VALVE SEAT WAS LEAKING, THE SEAT WAS REPAIRED.	830815	LK
F-CV-F	VALVE	301131004	THE CHECK VALVE SEAT WAS LEAKING, THE SEAT WAS REPAIRED.	830926	LK
2-CV-A	VALVE	311201520	THE CHECK VALVE SEAT WAS LEAKING, THE SEAT WAS DISASSEMBLED, REPAIR WAS NOT SPECIFIED.	831129	LK/00
2-CV-F	VALVE	312071055	THE CHECK VALVE SEAT WAS LEAKING, THE SEAT WAS INSPECTED, REPAIR WAS NOT SPECIFIED.	831213	LK
2-CV-D	VALVE	403271000	THE VALVE WAS INSPECTED, THE RESULTS WERE NOT SPECIFIED.	840406	LK
2-CV-D	VALVE	404031130	THE CHECK VALVE SEAT WAS LEAKING, THE SEAT WAS REPAIRED. COMBINE WITH 403271000.	840406	LK
2-CV-E	VALVE	403270840	THE CHECK VALVE SEAT WAS LEAKING, THE SEAT WAS REPAIRED.	840406	LK
2-CV-F	VALVE	404072152	THE CHECK VALVE SEAT WAS LEAKING, THE SEAT WAS REPAIRED.	840408	LK
2-CV-F	VALVE	404031540	THE CHECK VALVE SEAT WAS LEAKING, THE SEAT WAS REPAIRED. COMBINE WITH 404072152.	840408	LK
2-CV-F	VALVE	404070928	THE CHECK VALVE SEAT WAS LEAKING, THE SEAT WAS REPAIRED. COMBINE WITH 404072152.	840408	LK
2-CV-F	VALVE	404081000	THE VALVE WAS INSPECTED, THE RESULTS WERE NOT SPECIFIED. COMBINE WITH 404072152.	840408	LK
2-CV-F	VALVE	404021320	THE CHECK VALVE SEAT WAS LEAKING, THE SEAT WAS REPAIRED. COMBINE WITH 404072152.	840408	LK

\* LK - UNDETECTED LEAKAGE FAILURE    00 - BACKFLOW FAILURE

Table B.3.g. (continued)

MARK NO.	COMPONENT	M. R. #	PROBLEM/REPAIR SUMMARY	RTSVDT	CLASS*
2-CV-E	VALVE	1222	THE CHECK VALVE SEAT WAS LEAKING, THE SEAT WAS REPAIRED.	841114	LK
2-CV-D	VALVE	25924	THE CHECK VALVE SEAT WAS LEAKING, THE SEAT WAS REPAIRED.	861202	LK
2-CV-E	VALVE	30558	IT WAS NECESSARY TO INSPECT AND REPAIR THE VALVE, IT IS ASSUMED THAT IT WAS LEAKING.	870104	LK
1-CV-A	VALVE	49606	THE CHECK VALVE SEAT WAS LEAKING, THE SEAT WAS REPAIRED.	870214	LK/00
1-CV-A	VALVE	49048	THE CHECK VALVE SEAT WAS LEAKING, THE SEAT WAS REPAIRED. COMBINED WITH RECORD 49606.	870214	LK/00
1-CV-A	VALVE	53704	THE CHECK VALVE SEAT WAS LEAKING, THE SEAT WAS REPAIRED.	870528	LK/00

\* LK - UNDETECTED LEAKAGE FAILURE      00 - BACKFLOW FAILURE

**Table B.4**

**Maintenance Records Narrowly Classified  
as Failures for the Auxiliary Feedwater System,  
Rewritten Format**

Table B.4.a. MAINTENANCE RECORDS NARROWLY CLASSIFIED AS FAILURES FOR THE AUXILIARY FEEDWATER SYSTEM TURBINE DRIVEN FEED PUMPS, REWRITTEN FORMAT

MARK NO.	COMPONENT	M. R. #	PROBLEM/REPAIR SUMMARY	RTSVDT	CLASS*
1-TDP	PUMP	801010430	THE LUBRICATING OIL PRESSURE FAILED LOW RESULTING IN BEARING DAMAGE, REPLACED THRUST BEARING LINING.	780111	FR
2-TDP	PUMP	11170730	DEFICIENCIES IN THE OVERSPEED TRIP VALVE CAUSED A PUMP TRIP, THE LINKAGE WAS STRAIGHTENED.	801118	FR
2-TDP	PUMP	302111050	THE OVERSPEED TRIP CAUSED CAUSED INAPPROPRIATE PUMP TRIPS, THE OVERSPEED TRIP WAS CORRECTLY ADJUSTED.	830216	FR
2-TDP	PUMP	303181232	FAILURE OF THE OVERSPEED TRIP SPRING TO STAY ENGAGED LED TO A PUMP TRIP, THE SPRING WAS REINSTALLED.	830321	FR
1-TDP	PUMP	40487	THE GOVERNOR VALVE WOULD NOT OPEN, SPRING WAS REPLACED BUT THIS DID NOT HELP.	860907	FR
1-TDP	PUMP	41325	GOVERNOR WAS REMOVED AND OVERHAULED BECAUSE POOR OPERATION. (THIS EVENT SHOULD WAS COMBINED WITH RECORD 40487)	860927	FR
1-TDP	PUMP	40450	ADDITIONAL GOVERNOR WORK COMBINED WITH RECORD 40487.	860930	FR
1-TDP	PUMP	40488	ADDITIONAL GOVERNOR WORK COMBINED WITH RECORD 40487.	860930	FR
1-TDP	PUMP	40491	ADDITIONAL GOVERNOR WORK COMBINED WITH RECORD 40487.	860930	FR

\* FR - FAILURE TO RUN FS - FAILURE TO START



Table B.4.b. MAINTENANCE RECORDS NARROWLY CLASSIFIED AS FAILURES FOR THE AUXILIARY FEEDWATER SYSTEM MOTOR DRIVEN PUMPS, REWRITTEN FORMAT

MARK NO.	COMPONENT	M. R. #	PROBLEM/REPAIR SUMMARY	RTSVOT	CLASS*
2-MDP-B	PUMP	7222155	THE PUMP WOULD NOT START AUTOMATICALLY, IT WAS SOMEHOW REPAIRED.	800725	FS
1-MDP-A	PUMP	203261300	THE PUMP FAILED BECAUSE THE BREAKER TRIPPED OPEN, BREAKER SHUT SATISFACTORILY AFTER REPAIR. IT WAS ASSUMED THAT THE BREAKER TRIPPED ON PUMP START.	820330	FS
1-MDP-A	BREAKER	306072125	A PHASE A RELAY DROPPED OUT, IT IS ASSUMED THAT THE PUMP TRIPPED SINCE A MEGGER WAS REQUIRED DURING REPAIR.	830611	FS
2-MDP-A	RELAY	310060105	A RELAY COIL FAILED IN THE START OR POWER CIRCUIT AND IT IS ASSUMED THAT THE PUMP FAILED TO START, THE RELAY WAS REPLACED.	831012	FS

\* FR - FAILURE TO RUN    FS - FAILURE TO START

Table B.4.c. MAINTENANCE RECORDS NARROWLY CLASSIFIED AS FAILURES FOR THE AUXILIARY FEEDWATER SYSTEM 3-INCH MOTOR OPERATED VALVES, REWRITTEN FORMAT

MARK NO.	COMPONENT	M. R. #	PROBLEM/REPAIR SUMMARY	RTSVDT	CLASS*
1-MOV-B	MOV	806302330	THE SUPPLY BREAKER TRIPPED OPEN AND COULD NOT BE RESET, THE BREAKER WAS REPAIRED.	780706	PG
2-MOV-A	MOV	810110135	THE VALVE DID NOT OPEN AUTOMATICALLY, THE CONTROL CIRCUIT WAS REPAIRED.	781015	PG
1-MOV-E	MOV	1061910	THE MOTOR HOUSING FOR THE VALVE SHATTERED AND HAD TO BE REPLACED, IT WAS REPLACED WITH 251E MOTOR.	800107	PG
1-MOV-E	MOV	1061825	POWER WAS DISCONNECTED AND RECONNECTED TO FACILITATE MOTOR REPLACEMENT. COMBINE WITH 1061910.	800219	PG
2-MOV-E	MOV	1062046	THE MOTOR (AND MAYBE THE VALVE?) WAS REMOVED FOR USE ON UNIT 1. COMBINE WITH 106190.	800323	PG
2-MOV-F	VALVE	4291230	THE MOTOR WAS DISASSEMBLED FOR INSPECTION AND FOUND TO BE STUCK, IT WAS REPAIRED.	800509	PG
2-MOV-D	MOV	5281601	THE SUPPLY BREAKER TRIPPED OPEN APPARENTLY ON OVERLOAD, A (TORQUE?) SWITCH WAS ADJUSTED TO FIX THE MOV.	800602	PG
2-MOV-B	MOV	11011730	THE MOV WOULD NOT OPERATE AND BAD LEADS WERE FOUND, THE LEADS WERE REPAIRED.	801104	PG
1-MOV-F	MOV	110011750	THE MOV INDICATED CLOSED LOCALLY, THE VALVE WAS FOUND NOT TO OPERATE SATISFACTORILY.	811001	PG
1-MOV-F	MOV	208140700	THE OPERATOR WAS REPLACED.	820814	PG
1-MOV-F	MOV	208120135	THE VALVE WOULD NOT OPERATE AND CAUSED THE BREAKER TO TRIP ON THERMAL OVERLOAD. COMBINE WITH RECORD 208140700.	820814	PG
2-MOV-C	VALVE	304230659	THE DRIVE MECHANISM WAS FOUND TO BE BROKEN, THE OPERATOR WAS REPLACED.	830426	PG
1-MOV-D	MOV	305111830	THE VALVE CLOSED APPARENTLY WHEN IT SHOULD NOT HAVE, IT IS NOT APPARENT FROM THE SUMMARY HOW THE VALVE WAS REPAIRED.	830520	PG

B-87

\* PG - PLUGGING FAILURE

Table B.4.c. (continued)

MARK NO.	COMPONENT	M. R. #	PROBLEM/REPAIR SUMMARY	RTSVDT	CLASS*
1-MOV-D	VALVE	406140300	LIMIT SWITCH GEAR WAS WORN AND WAS REPLACED, COMBINED WITH RECORD 406190408.	840614	PG
1-MOV-D	VALVE	406191135	THE GEAR ASSEMBLY WAS REPLACED, COMBINED WITH RECORDS 406190408.	840620	PG
1-MOV-D	VALVE	406190408	THE VALVE WOULD NOT CLOSE OR OPEN, THE LIMITS WERE REPLACED.	840620	PG
1-MOV-D	MOV	13893	THE SUPPLY BREAKER TRIPPED, IT WAS CHECKED.	850213	PG
1-MOV-D	MOV	22962	THE SUPPLY BREAKER TRIPPED, IT WAS CHECKED.	850814	PG
2-MOV-A	MOV	20540	COIL IN LATCHING RELAY FAILED, IT WAS REPLACED.	851029	PG
1-MOV-D	MOV	29885	BREAKER TRIPPED ON THERMAL OVERLOAD, OVERLOADS RESET, NO FURTHER FAILURES.	860128	PG
2-MOV-D	MOV	37688	VALVE DID NOT OPERATE BECAUSE AUXILIARY CONTACTS WERE STUCK, CONTACTS REPAIRED.	860715	PG
1-MOV-E	MOV	29920	VALVE DID NOT OPEN DUE TO A STUCK INTERLOCK IN OPENING CIRCUIT. CONTACTOR REPLACED.	870219	PG

\* PG - PLUGGING FAILURE

Table B.4.d MAINTENANCE RECORDS NARROWLY CLASSIFIED AS FAILURES FOR THE AUXILIARY FEEDWATER SYSTEM 6-INCH MOTOR OPERATED VALVES, REWRITTEN FORMAT

MARK NO.	COMPONENT	M. R. #	PROBLEM/REPAIR SUMMARY	RTSVDT	CLASS*
2-MOV-J	VALVE	810030726	THE VALVE WOULD NOT OPERATE, UNSPECIFIED REPAIRS WERE MADE AND THE VALVE WAS TESTED.	781006	FC
2-MOV-J	MOV	812040631	THE SUPPLY BREAKER TRIPPED ON THERMAL OVERLOAD, THE VALVE WAS CLEANED AND THEN TESTED.	781204	FC
2-MOV-I	MOV	7231425	THE VALVE WAS BINDING UP, UNSPECIFIED REPAIRS WERE MADE. COMBINE WITH 8050929.	800801	FC
2-MOV-I	MOV	8050929	THE LIMITORQUE OPERATOR WAS REPLACED OR REPAIRED.	800807	FC
2-MOV-J	VALVE	101131200	THE VALVE WAS BINDING AND WOULD NOT CLOSE, THE STEM THREADS WERE CLEANED.	810120	FC
1-MOV-G	MOV	112120420	THE VALVE WOULD NOT CYCLE, THE LIMITS WERE ADJUSTED.	811212	FC
1-MOV-H	MOV	30387	VALVE WOULD NOT STROKE, IT WAS CHECKED.	860211	FC

\* FC - CROSS-CONNECTING FAILURE

Table B.4.e. MAINTENANCE RECORDS NARROWLY CLASSIFIED AS FAILURES FOR THE AUXILIARY FEEDWATER SYSTEM 3-INCH CHECK VALVES, REWRITTEN FORMAT

MARK NO.	COMPONENT	M. R. #	PROBLEM/REPAIR SUMMARY	RTSVDT	CLASS*
2-CV-H	VALVE	312071039	THE CHECK VALVE SEAT WAS LEAKING, THE SEAT WAS REPAIRED.	831214	LK
2-CV-I	VALVE	312071040	THE CHECK VALVE SEAT WAS LEAKING, THE SEAT WAS REPAIRED.	831221	LK
2-CV-J	VALVE	312071041	THE CHECK VALVE SEAT WAS LEAKING, THE SEAT WAS REPAIRED.	831221	LK
1-CV-H	VALVE	312160902	THE CHECK VALVE SEAT WAS LEAKING, THE SEAT WAS REPAIRED.	840107	LK

\* LK - UNDETECTED LEAKAGE FAILURE

Table B.4.f. MAINTENANCE RECORDS NARROWLY CLASSIFIED AS FAILURES FOR THE AUXILIARY FEEDWATER SYSTEM 4-INCH CHECK VALVES, REWRITTEN FORMAT

MARK NO.	COMPONENT	M. R. #	PROBLEM/REPAIR SUMMARY	RTSVDT	CLASS*
1-CV-C	VALVE	304291402	THE CHECK VALVE SEAT WAS LEAKING, THE SEAT WAS REPAIRED.	830504	LK
1-CV-B	VALVE	304291400	THE CHECK VALVE SEAT WAS LEAKING, THE SEAT WAS REPAIRED.	830525	LK
2-CV-C	VALVE	305040509	THE CHECK VALVE SEAT WAS LEAKING, THE SEAT WAS REPAIRED.	830926	LK
2-CV-C	VALVE	311181137	THE CHECK VALVE SEAT WAS LEAKING, THE SEAT WAS INSPECTED.	831119	LK
2-CV-C	VALVE	311201310	THE CHECK VALVE SEAT WAS LEAKING, THE SEAT WAS INSPECTED. COMBINE WITH 311181137.	831120	LK
2-CV-C	VALVE	401270925	THE CHECK VALVE SEAT WAS LEAKING, THE SEAT WAS REPAIRED.	840128	LK
2-CV-C	VALVE	403070933	THE CHECK VALVE SEAT WAS LEAKING, THE VALVE WAS CHECKED.	840313	LK

\* LK - INCIPIENT UNDETECTED LEAKAGE FAILURE

Table B.4.g. MAINTENANCE RECORDS NARROWLY CLASSIFIED AS FAILURES FOR THE AUXILIARY FEEDWATER SYSTEM 6-INCH CHECK VALVES, REWRITTEN FORMAT

MARK NO.	COMPONENT	M. R. #	PROBLEM/REPAIR SUMMARY	RTSVDT	CLASS*
2-CV-A	VALVE	301131150	THE CHECK VALVE SEAT WAS LEAKING, THE SEAT WAS REPAIRED.	830117	LK
2-CV-F	VALVE	304212311	THE CHECK VALVE SEAT WAS LEAKING, THE SEAT WAS REPAIRED.	830426	LK
2-CV-G	VALVE	304212312	THE CHECK VALVE SEAT WAS LEAKING, THE SEAT WAS REPAIRED.	830426	LK
1-CV-A	VALVE	304291401	THE CHECK VALVE SEAT WAS LEAKING, THE SEAT WAS REPAIRED.	830520	LK
2-CV-D	VALVE	301131002	THE CHECK VALVE SEAT WAS LEAKING, THE SEAT WAS REPAIRED.	830815	LK
2-CV-F	VALVE	301131004	THE CHECK VALVE SEAT WAS LEAKING, THE SEAT WAS REPAIRED.	830926	LK
2-CV-A	VALVE	311201520	THE CHECK VALVE SEAT WAS LEAKING, THE SEAT WAS DISASSEMBLED, REPAIR WAS NOT SPECIFIED.	831129	LK
2-CV-F	VALVE	312071055	THE CHECK VALVE SEAT WAS LEAKING, THE SEAT WAS INSPECTED, REPAIR WAS NOT SPECIFIED.	831213	LK
2-CV-D	VALVE	404031130	THE CHECK VALVE SEAT WAS LEAKING, THE SEAT WAS REPAIRED. COMBINE WITH 403271000.	840406	LK
2-CV-E	VALVE	403270840	THE CHECK VALVE SEAT WAS LEAKING, THE SEAT WAS REPAIRED.	840406	LK
2-CV-F	VALVE	404072152	THE CHECK VALVE SEAT WAS LEAKING, THE SEAT WAS REPAIRED.	840408	LK
2-CV-F	VALVE	404031540	THE CHECK VALVE SEAT WAS LEAKING, THE SEAT WAS REPAIRED. COMBINE WITH 404072152.	840408	LK
2-CV-F	VALVE	404070928	THE CHECK VALVE SEAT WAS LEAKING, THE SEAT WAS REPAIRED. COMBINE WITH 404072152.	840408	LK
2-CV-F	VALVE	404021320	THE CHECK VALVE SEAT WAS LEAKING, THE SEAT WAS REPAIRED. COMBINE WITH 404072152.	840408	LK
2-CV-E	VALVE	1222	THE CHECK VALVE SEAT WAS LEAKING, THE SEAT WAS REPAIRED.	841114	LK
2-CV-D	VALVE	25924	THE CHECK VALVE SEAT WAS LEAKING, THE SEAT WAS REPAIRED.	861202	LK
1-CV-A	VALVE	49606	THE CHECK VALVE SEAT WAS LEAKING, THE SEAT WAS REPAIRED.	870214	LK
1-CV-A	VALVE	49048	THE CHECK VALVE SEAT WAS LEAKING, THE SEAT WAS REPAIRED. COMBINED WITH RECORD 49606.	870214	LK
1-CV-A	VALVE	53704	THE CHECK VALVE SEAT WAS LEAKING, THE SEAT WAS REPAIRED.	870528	LK

\* LK - UNDETECTED LEAKAGE FAILURE.

**BIBLIOGRAPHIC DATA SHEET**

(See instructions on the reverse)

1. REPORT NUMBER  
(Assigned by NRC, Add Vol., Supp., Rev.,  
and Addendum Numbers, if any.)

NUREG/CR-5378  
EGG-2567

2. TITLE AND SUBTITLE

Aging Data Analysis and Risk Assessment--Development  
and Demonstration Study

3. DATE REPORT PUBLISHED

MONTH | YEAR

August | 1992

4. FIN OR GRANT NUMBER

A6389

5. AUTHOR(S)

A. J. Wolford\*, C. L. Atwood, W. S. Roesener

6. TYPE OF REPORT

Technical

7. PERIOD COVERED (Inclusive Dates)

8. PERFORMING ORGANIZATION - NAME AND ADDRESS (If NRC, provide Division, Office or Region, U.S. Nuclear Regulatory Commission, and mailing address; if contractor, provide name and mailing address.)

Idaho National Engineering Laboratory  
EG&G Idaho, Inc.  
Idaho Falls, ID 83415

\*DNV Technica  
355 East Campus View Blvd.  
Suite 710  
Columbus, OH 43235

9. SPONSORING ORGANIZATION - NAME AND ADDRESS (If NRC, type "Same as above"; if contractor, provide NRC Division, Office or Region, U.S. Nuclear Regulatory Commission, and mailing address.)

Division of Engineering  
Office of Nuclear Regulatory Research  
U.S. Nuclear Regulatory Commission  
Washington, DC 20555

10. SUPPLEMENTARY NOTES

11. ABSTRACT (200 words or less)

This work develops and demonstrates a probabilistic risk assessment (PRA) approach to assess the effect of aging and degradation of active components on plant risk. The work (a) develops a way to identify and quantify age-dependent failure rates of active components, and to incorporate them into PRA; (b) demonstrates the approach by applying it to a fluid-mechanical system, using the key elements of a NUREG-1150 PRA; and (c) presents it as a step-by-step approach, to be used for evaluating the risk significance of aging phenomena in systems of interest.

The approach uses statistical tests to detect increasing failure rates and for testing data-pooling assumptions and model adequacy. The component failure rates are assumed to change over time, with several forms used to model the age dependence—exponential, Weibull, and linear. Confidence intervals for the age-dependent failure rates are found and used to develop inputs to a PRA model in order to determine the plant core damage frequency. The approach was used with plant-specific data, obtained from maintenance work requests for the auxiliary feedwater system of an older pressurized water reactor. The approach can be used for extrapolating present trends into the near future and for supporting risk-based aging management decisions.

12. KEY WORDS/DESCRIPTORS (List words or phrases that will assist researchers in locating the report.)

Management of Aging  
Probabilistic Risk Assessment

13. AVAILABILITY STATEMENT

Unlimited

14. SECURITY CLASSIFICATION

(This Page)

Unclassified

(This Report)

Unclassified

15. NUMBER OF PAGES

16. PRICE



THIS DOCUMENT WAS PRINTED USING RECYCLED PAPER

**UNITED STATES**  
**NUCLEAR REGULATORY COMMISSION**  
WASHINGTON, D.C. 20555-0001

POSTAGE AND FEES PAID  
USNRC  
PERMIT NO. G-67

OFFICIAL BUSINESS  
PENALTY FOR PRIVATE USE, \$300