



PCA



Concrete Technology and Codes

In-Place Evaluation Methods



Evaluation of Concrete

- Visible features
 - ◆ Cracking, deterioration, deflections
- In-place strength
- Internal conditions
 - ◆ Corrosion of reinforcement
 - ◆ Voids
 - ◆ Honeycombing
 - ◆ Voids in tendon ducts
 - ◆ Delaminations
 - ◆ Member thickness



Tools

- Visual inspection
- Removal of samples
 - ◆ Core compressive strength
 - ◆ Petrographic analysis
- Tests for in-place uniformity
- In-place strength methods
- Stress-wave methods
- Ground penetrating radar
- Corrosion evaluation methods

ACI 228.2R-98

References

ACI 228.1R-03

Nondestructive Test Methods for
Evaluation of Concrete in Structures

In-Place Methods to Estimate
Concrete Strength

Reported by ACI Committee 228



Third edition

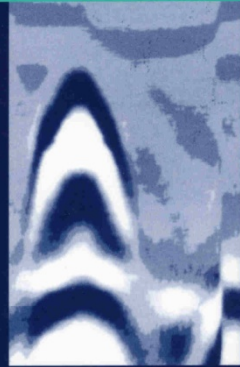

TESTING OF CONCRETE IN STRUCTURES

J.H. Bungey and S.G. Millard

BLACKIE ACADEMIC & PROFESSIONAL
An imprint of Chapman & Hall



HANDBOOK ON NONDESTRUCTIVE TESTING OF CONCRETE SECOND EDITION

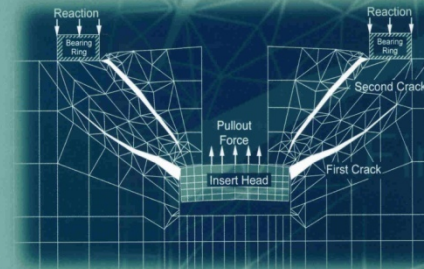

Edited by
V.M. MALHOTRA and N.J. CARINO



CRC PRESS

Concrete institute
P.O. BOX 9094
ANN ARBOR, MICHIGAN 48106-9094

ACI 349.3R

ACI 349.3R-02

Evaluation of Existing Nuclear Safety-Related Concrete Structures

Reported by ACI Committee 349

Ronald J. Janowiak*
Chair

Hans G. Ashar*
Ranjit L. Bandyopadhyay
Ronald A. Cook
Branko Galunic
Herman L. Graves, III
Gunnar A. Harstead

Christopher Heinz
Charles J. Hookham*
Jagadish R. Joshi
Richard E. Klingner
Daniel J. Naus
Dragos A. Nuta

Richard S. Orr
Barendra K. Talukdar
Donald T. Ward
Albert Y. C. Wong
Charles A. Zalesiak*

*Members of subcommittee authoring this report.

This report recommends guidelines for the evaluation of existing nuclear safety-related concrete structures. The purpose of this report is to provide the plant owner and engineering staff with an appropriate procedure and background for examining the performance of facility structures and taking appropriate actions based on observed conditions. Methods of examination, including visual inspection and testing techniques, and their recommended applications are cited. Guidance related to acceptance criteria for various forms of degradation is provided.

CONTENTS

- Chapter 1—Introduction, p. 349.3R-2**
- Chapter 2—General methodology, p. 349.3R-2**
- Chapter 3—Evaluation procedure, p. 349.3R-3**
 - 3.1—Scope
 - 3.2—Selective evaluation

ACI 364.1R

ACI 364.1R-07

Guide for Evaluation of Concrete Structures before Rehabilitation

Reported by ACI Committee 364

Fred R. Goodwin
Chair

Alexander M. Vaysburd
Secretary

Sam Bhuyan
Benoit Bissonnette
Michael L. Brainerd
Christopher D. Brown
Douglas Burke
Ashok K. Dhingra
Boris Dragunsky
Peter H. Emmons
Paul E. Gaudette
Timothy R. W. Gillespie

Zareh B. Gregorian
Pawan R. Gupta
Ronald E. Heffron
Robert L. Henry
Kal R. Hindo
Charles J. Hookham
Lawrence F. Kaha
Ashok M. Kakade
Dov Kaminetzky
Keith E. Kesner

Erick N. Larson
James L. Loper
Pritpal S. Mangat
James E. McDonald
Martin S. McGovern
William R. Nash
Mark A. Postma
David W. Scott
Robert E. Shewmaker
K. Nam Shiu

Avanti C. Shroff
Thomas E. Spencer
John A. Tanner
Valery Tokar
David A. VanOcker
Kurt F. Von Fay
James Warner
Patrick M. Watson
David W. Whitmore

This guide presents general procedures for evaluation of concrete structures before rehabilitation. Among the subjects covered are: preliminary investigation, detailed investigation, documentation, field observation and condition survey, sampling and material testing, evaluation, and final report. Evaluation to identify seismic deficiencies is beyond the scope of this report.

Keywords: concrete; condition survey, deterioration; distress; evaluation, investigation, rehabilitation; sampling; testing.

2.2—Investigation: overview
2.3—Preliminary investigation
2.4—Detailed investigation
2.5—Document review
2.6—Field investigation
2.7—Sampling and material testing
2.8—Evaluation
2.9—Report



Outline

- Tests for uniformity
- Tests for in-place strength
- Methods to locate internal defects
- Evaluation of corrosion



Tests for Uniformity

- Determine which portions of structure are similar
- Identify areas for further investigation by other means
- Methods
 - ◆ Rebound number (hammer)—ASTM C805
 - ◆ Ultrasonic pulse velocity—ASTM C597



Rebound Number (Hammer) ASTM C805

Measure the rebound of spring-driven mass (hammer) after impact with rod in contact with concrete.

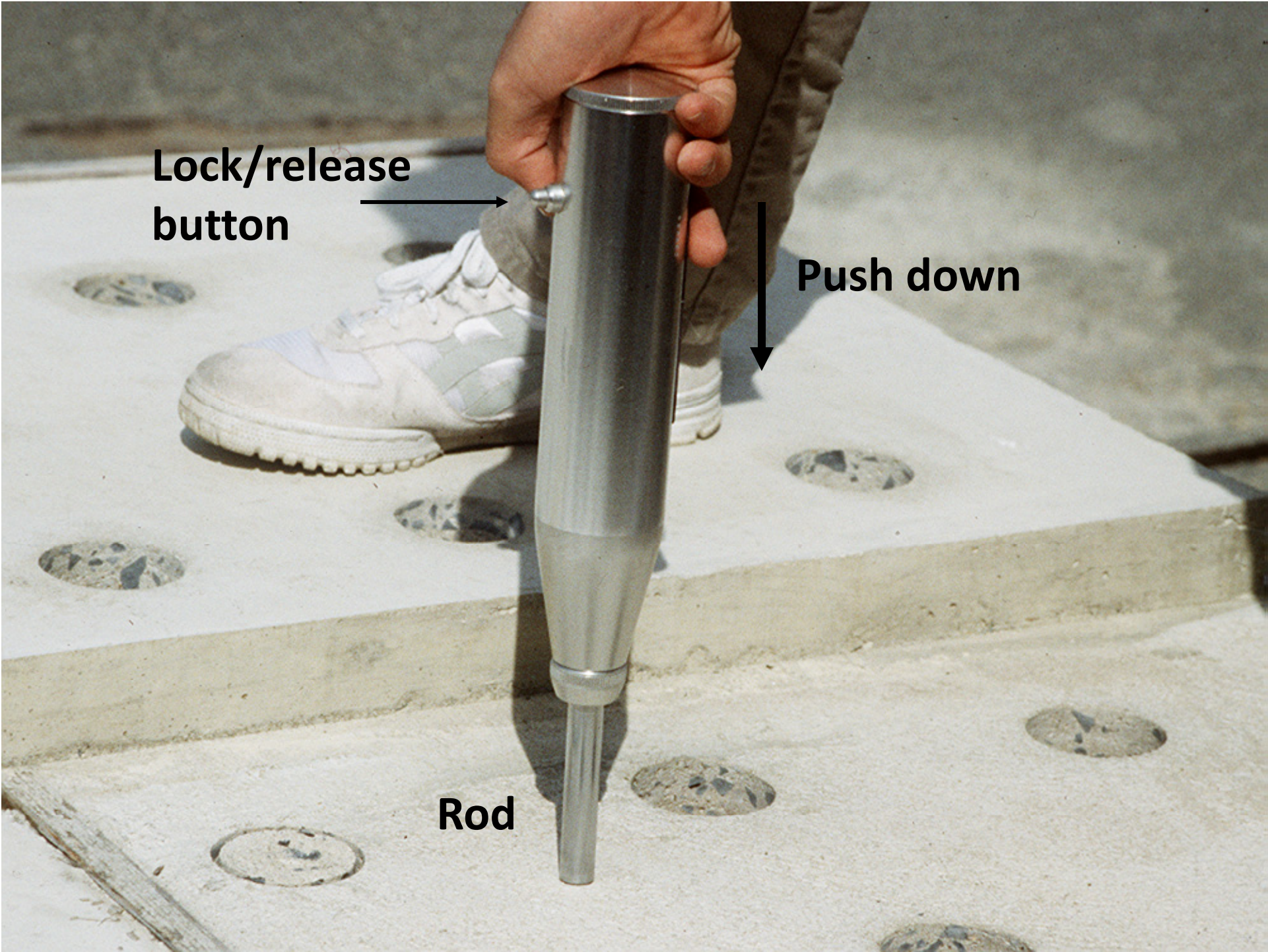

**Lock/release
button**

Push down

Rod

Rebound Hammer

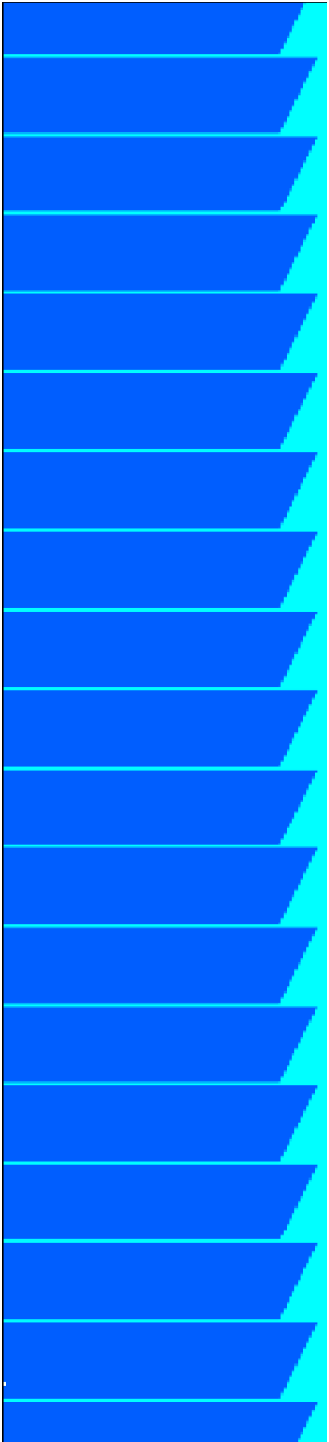

Operation

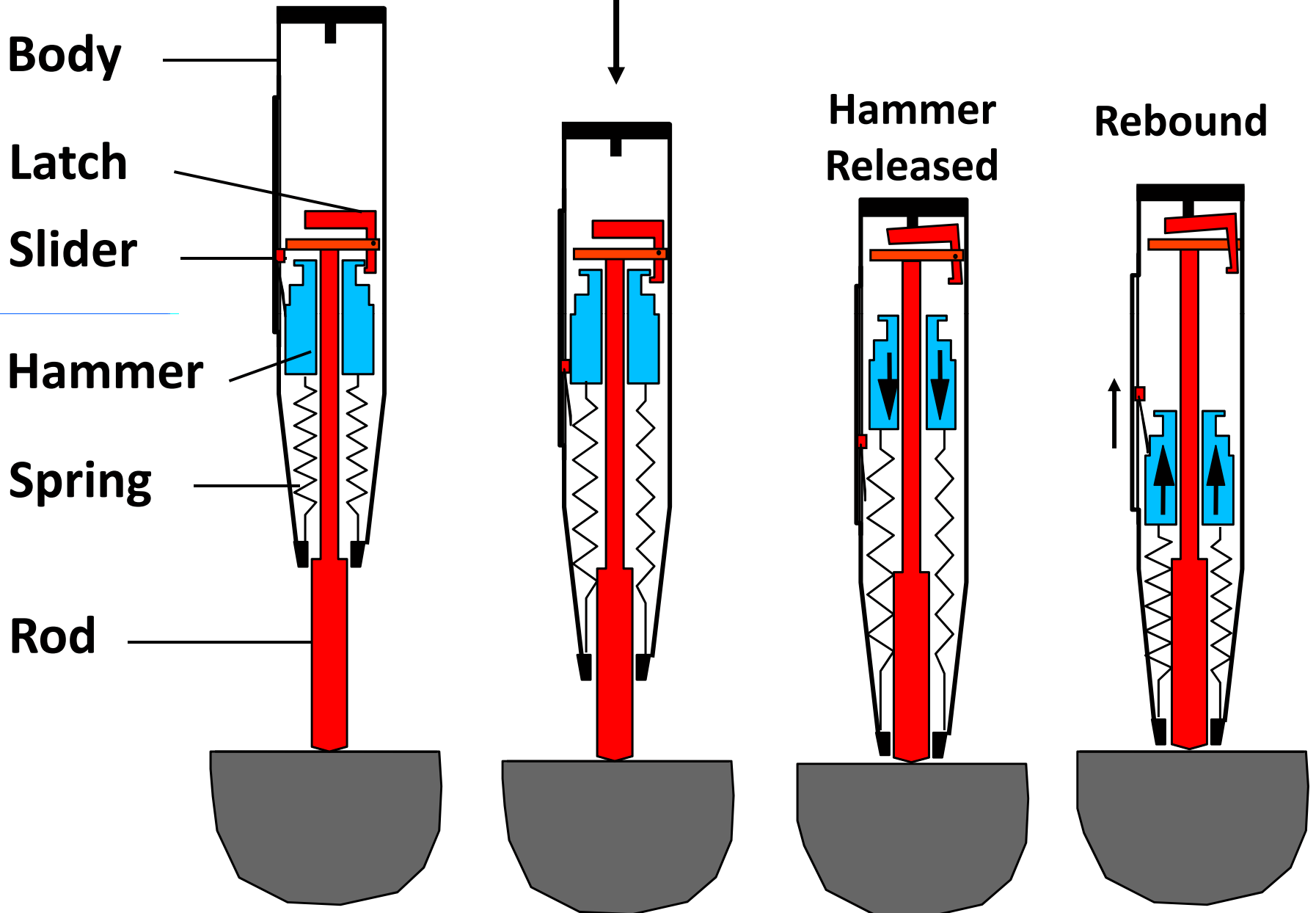

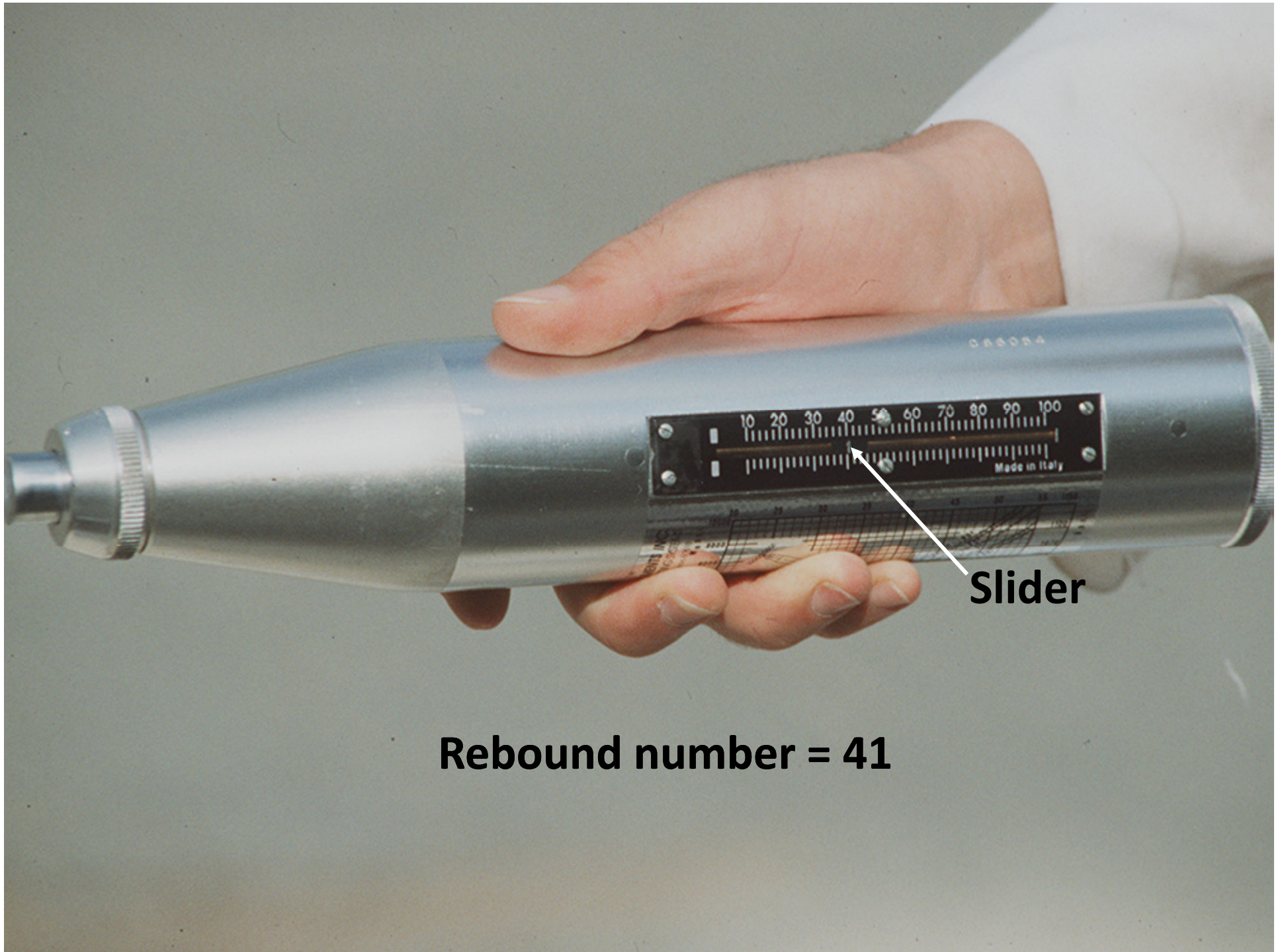

Rebound number = 41

Near-surface Effects

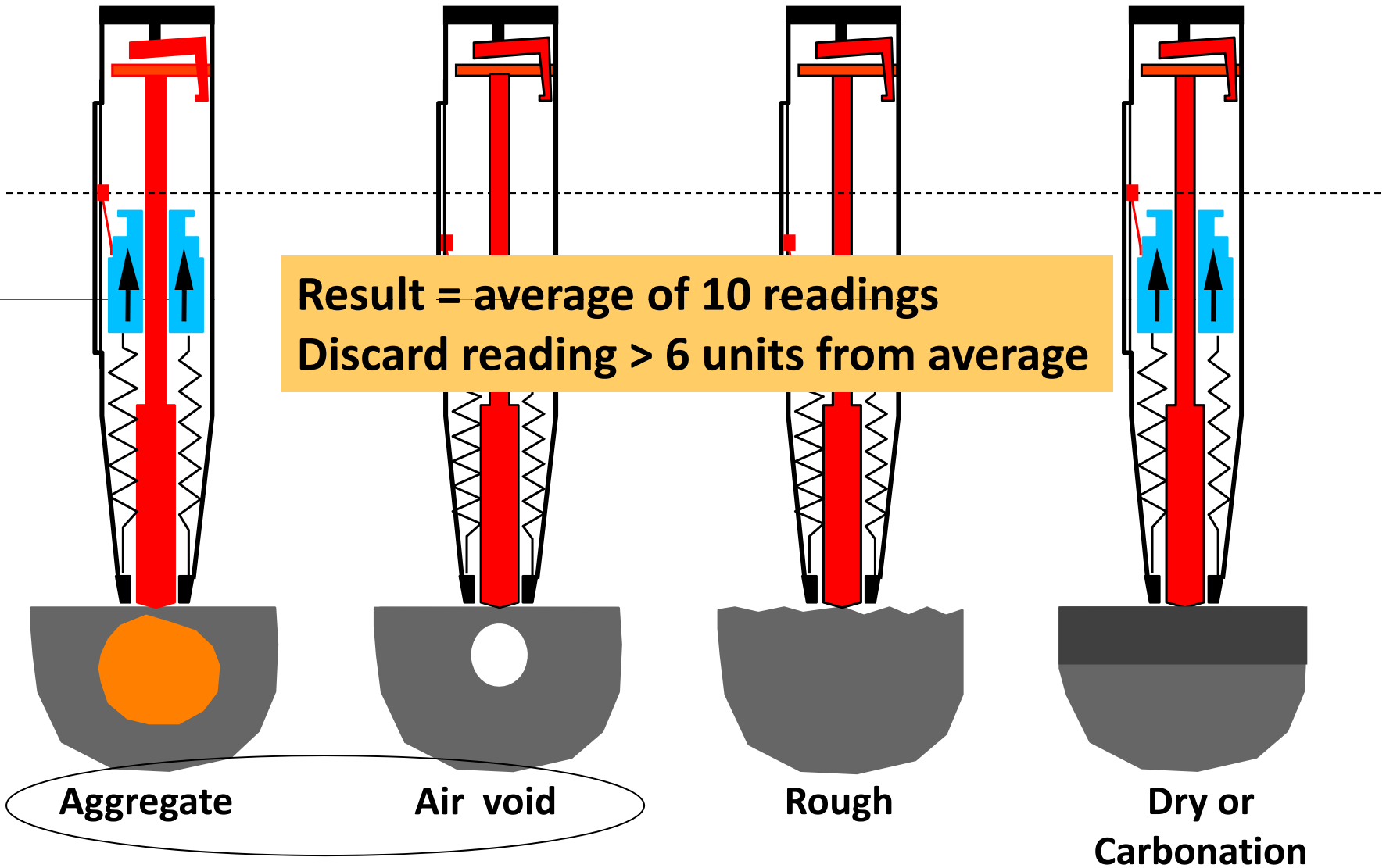



Factors Affecting Rebound Number

- Strength and elastic modulus of near surface concrete
- Layer of carbonation
- Surface texture
- Surface moisture condition



To Estimate Strength

- The only reliable approach is to correlate rebound number with strength of cores
- Need at least 6 strength levels (ACI 228.1R)
- Thus at least 12 cores to establish a correlation

Example

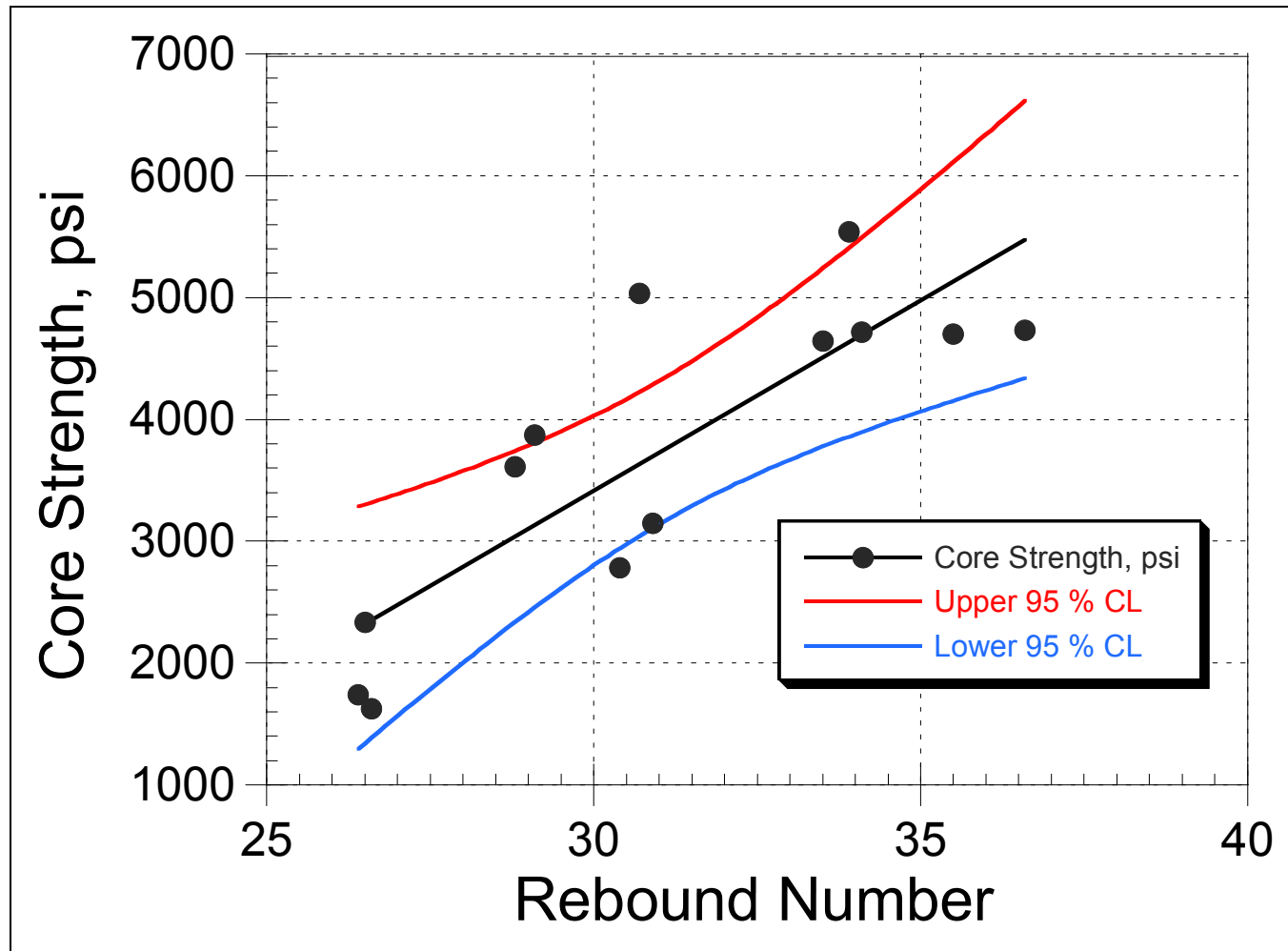

Ward, M.A. and Langan, B.W., *Cement Concrete and Aggregates*, 16(2), Dec. 1994, 181-185



Ultrasonic Pulse Velocity ASTM C597

Measure travel time of ultrasonic pulse
(compressional stress wave) over known
path length.



Stress Wave

- A disturbance that transfers energy progressively from point to point in a medium

WebFiles\waves-intro.html

- Speed of compression stress wave in concrete:

$$C_p \approx 1.05 \sqrt{\frac{E}{\rho}}$$

- For “good” concrete: $C_p \approx 4000$ m/s

<http://www.kettering.edu/~drussell/Demos/waves-intro/waves-intro.html>

UPV—Principle of Operation

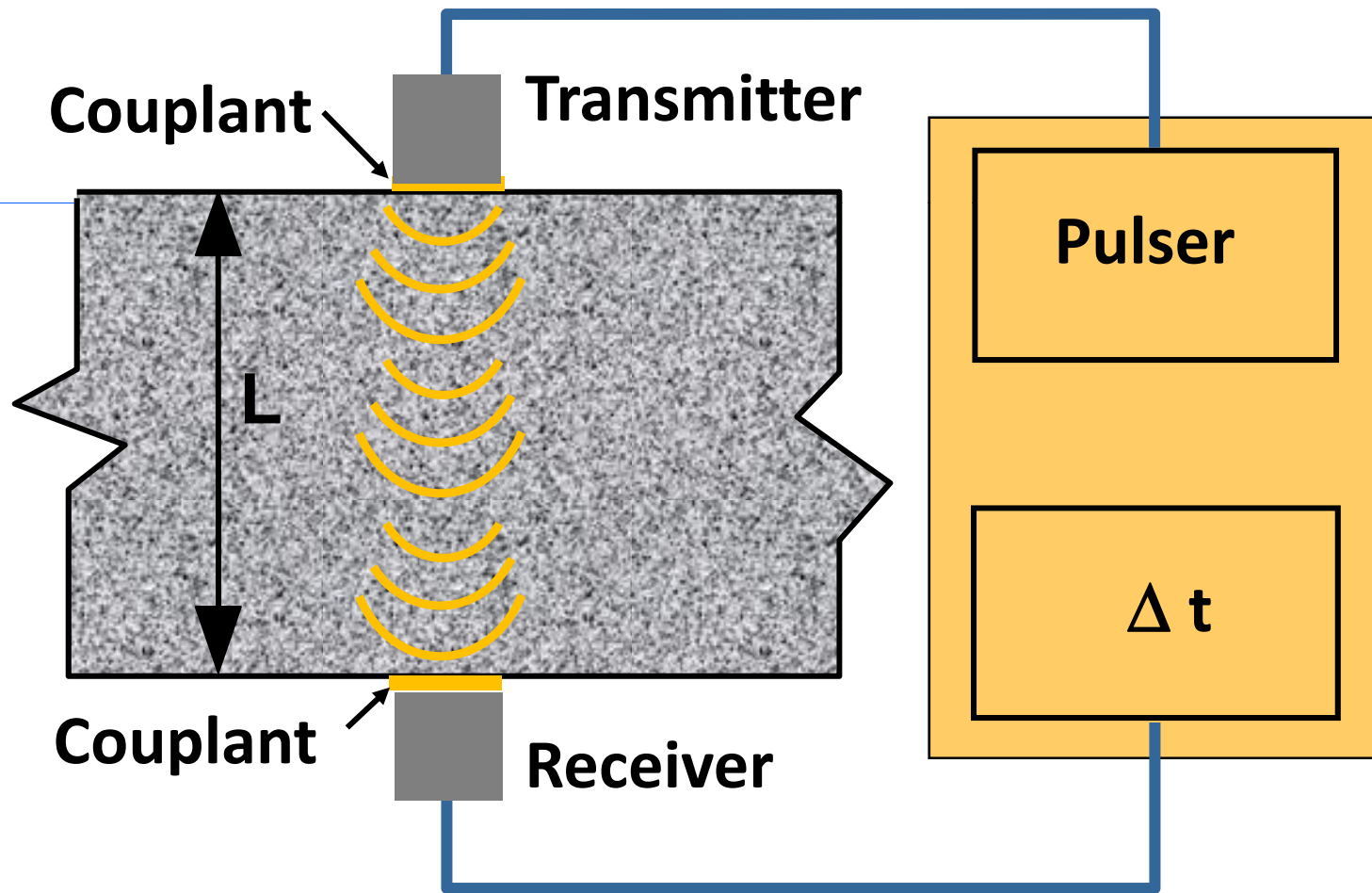

$$C_p = \frac{L}{\Delta t}$$

Example

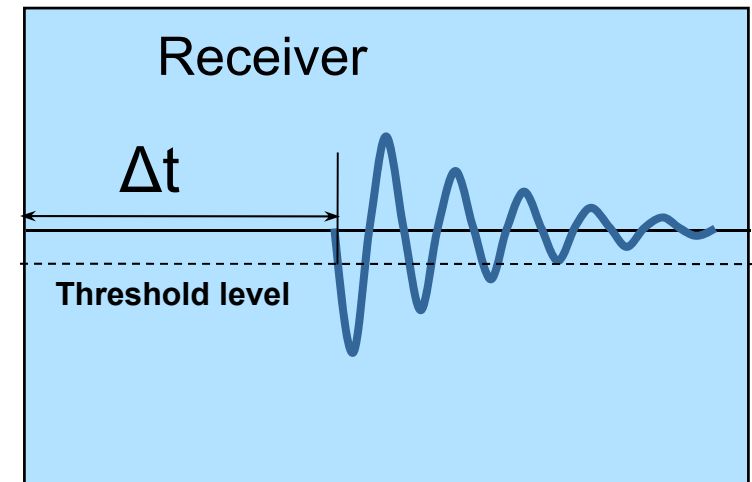
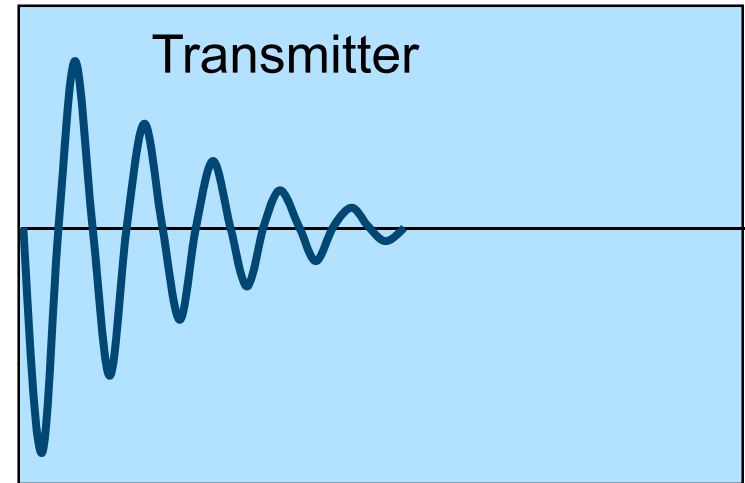
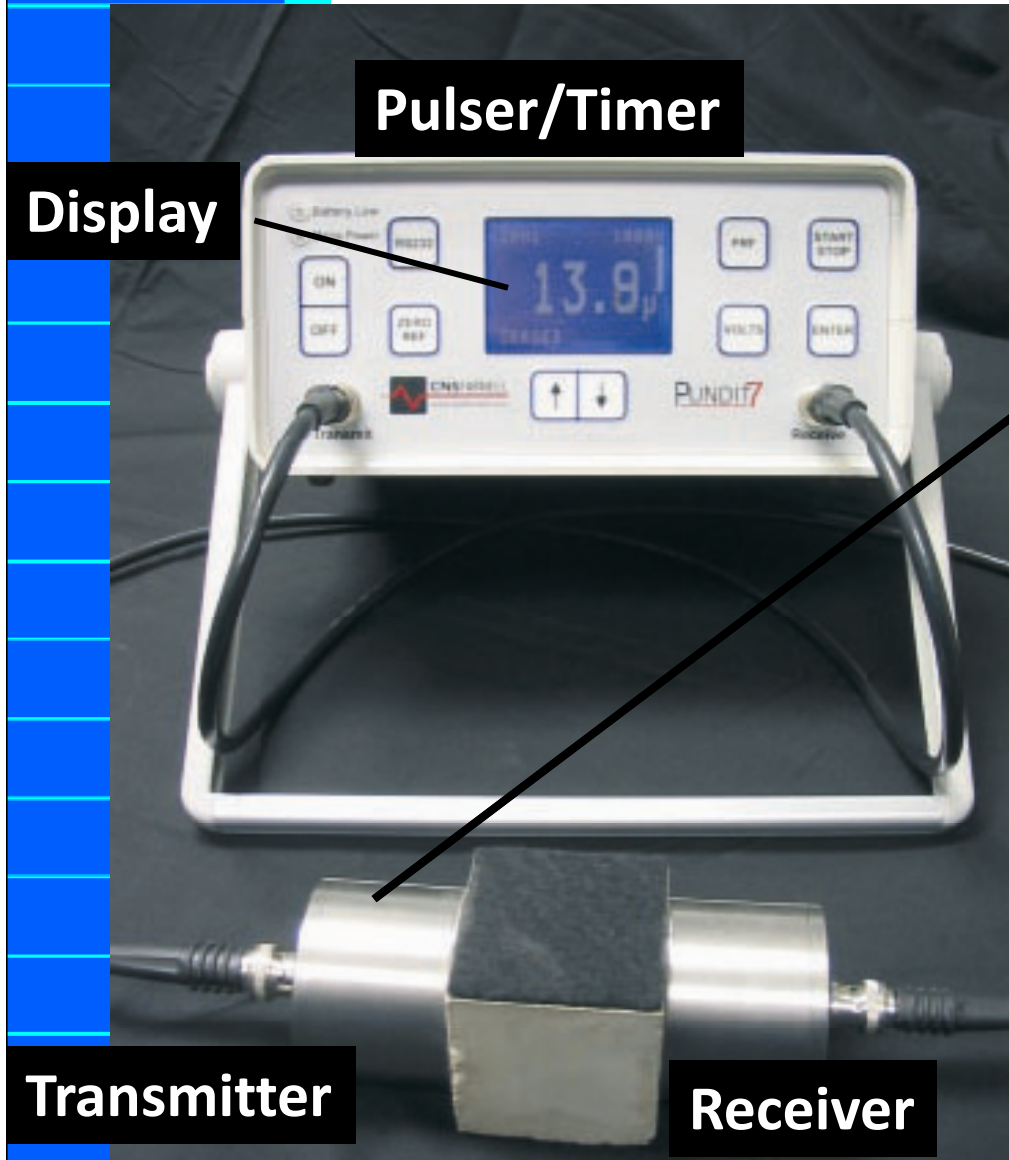

Courtesy of CNS Farnell

Measurement Paths

Direct path



Semi-direct path

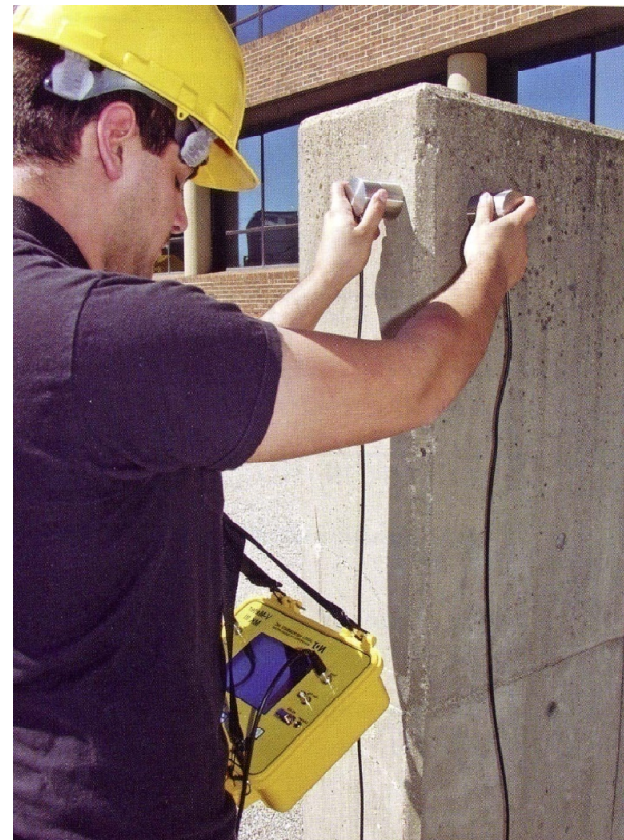

Courtesy of James Instruments Inc.

Effects of Internal Defects

Presence of "defects" increases travel time, and results in lower computed speed.

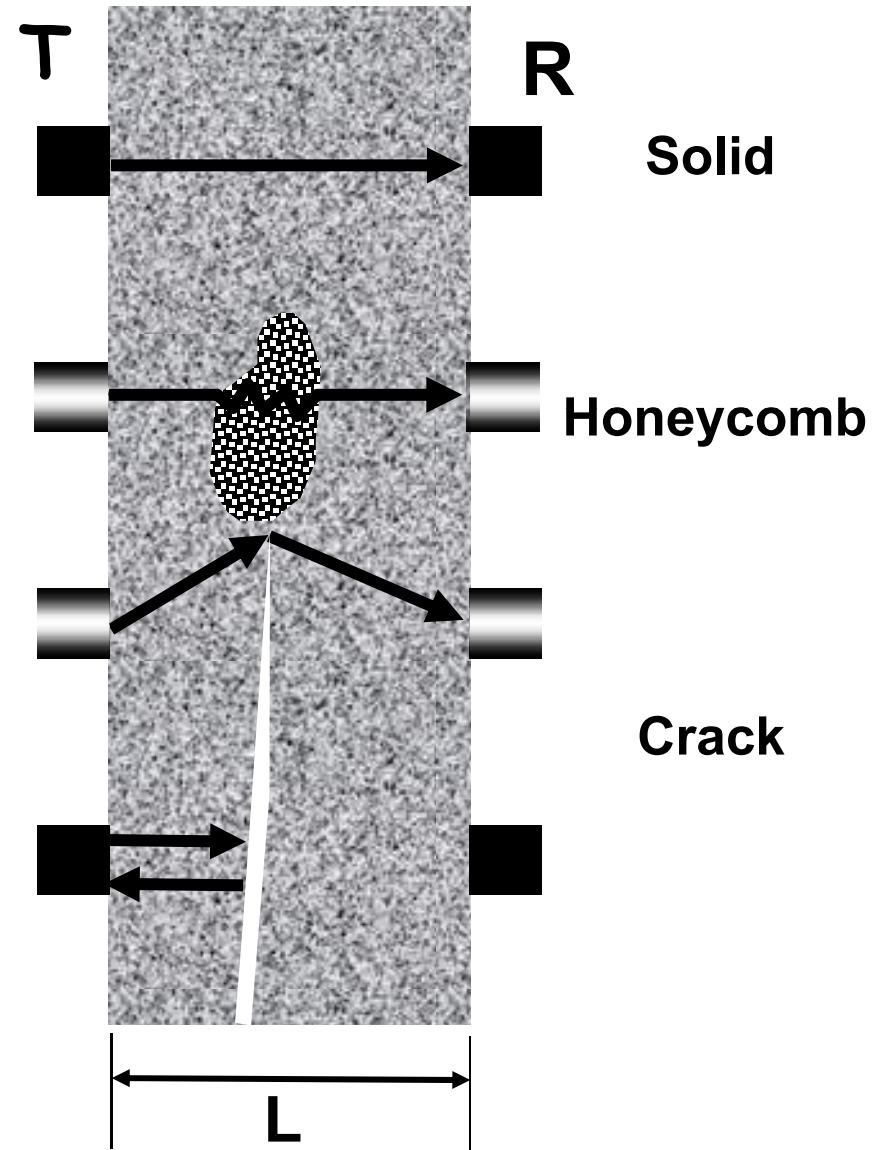

Assessment of Uniformity

- Draw grid on the surface of test object
- Perform tests at grid points
 - ◆ Test at same points to assess age related deterioration
- Plot UPV contours

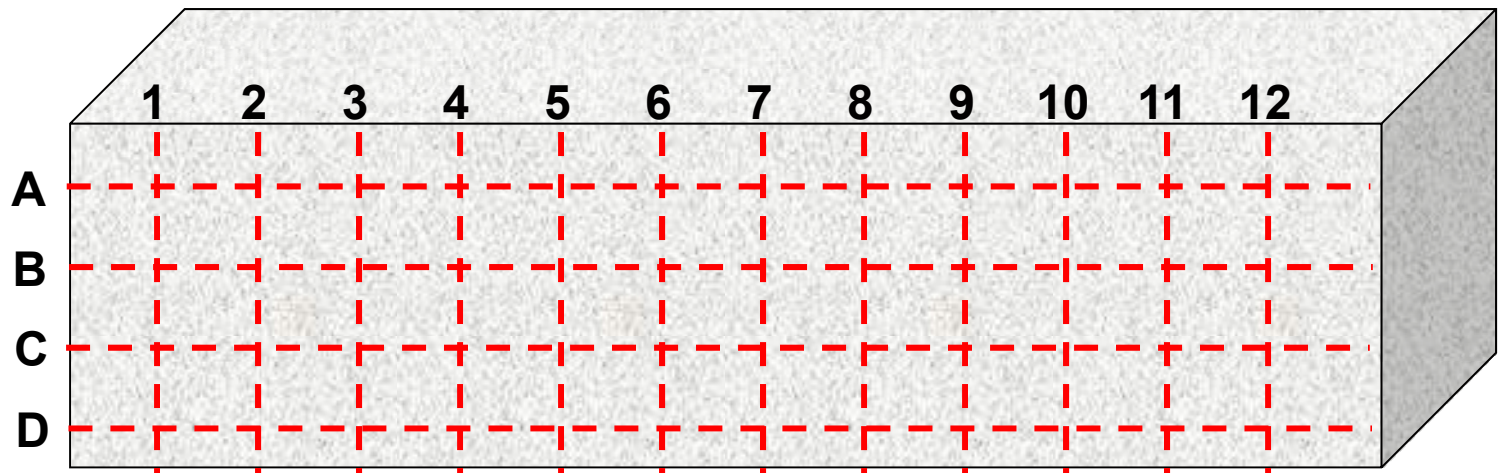

Assessment of Uniformity

- Draw grid on the surface of test object
- Perform tests at grid points
 - ◆ Test at same points to assess age related deterioration
- Plot UPV contours

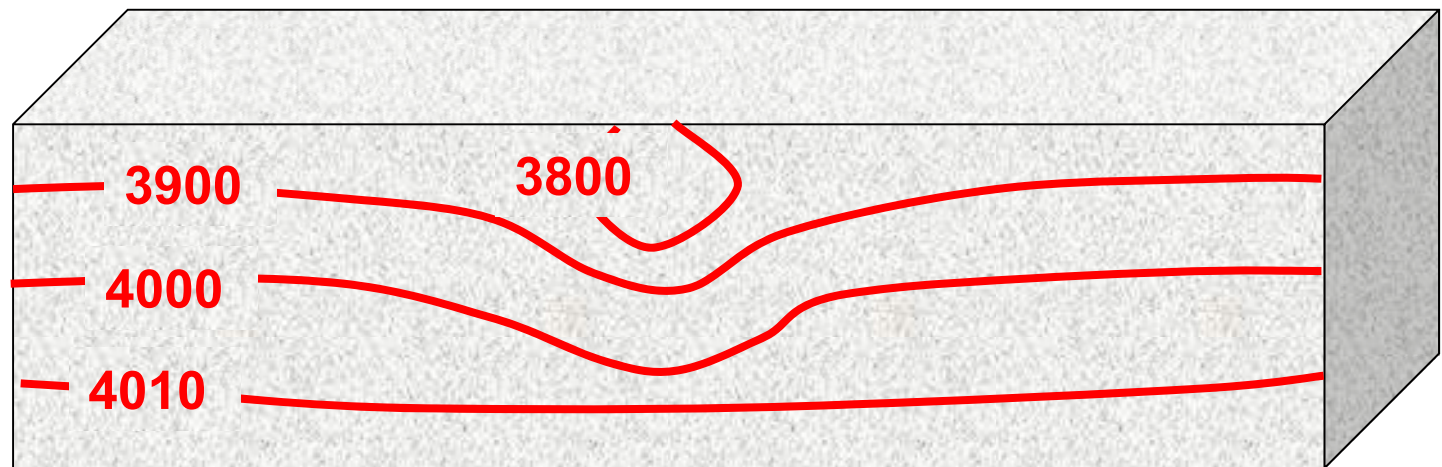

Depth of Surface Damage

- UPV Method can be used to estimate depth of damaged concrete (such as by fire)
 - ◆ Requires distinct boundary between sound and damaged concrete
 - ◆ Multiple travel time measurements along surface

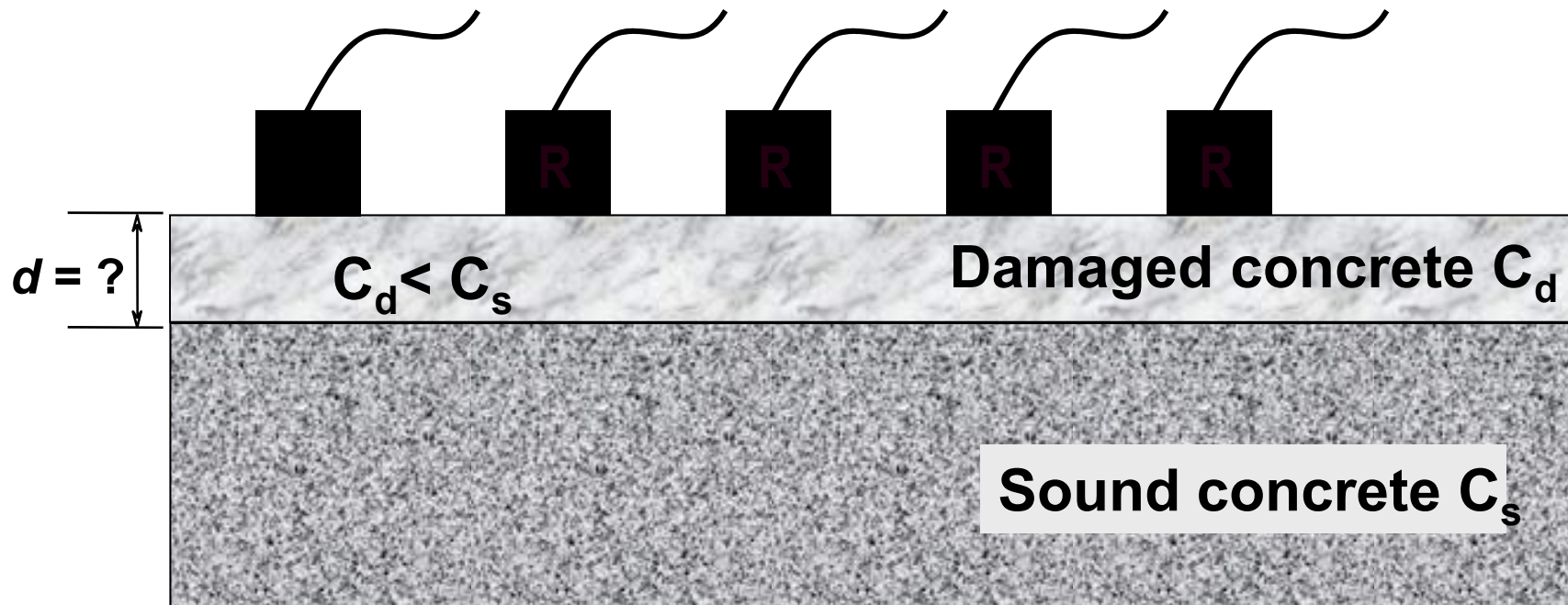

Depth of Surface Damage

- There are two ray paths
 - ◆ Path 1: through damage concrete
 - ◆ Path 2: through damaged concrete and sound concrete
- For certain separation, X_0 , transit times are equal

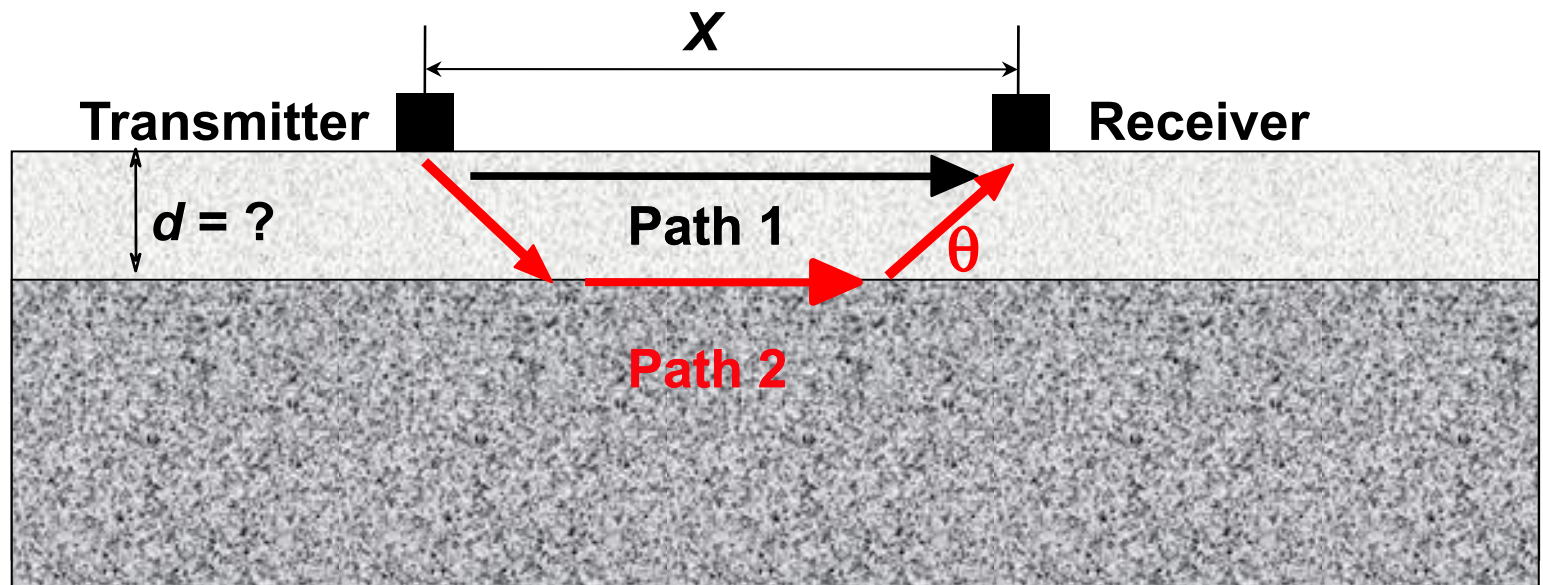

Determination of d

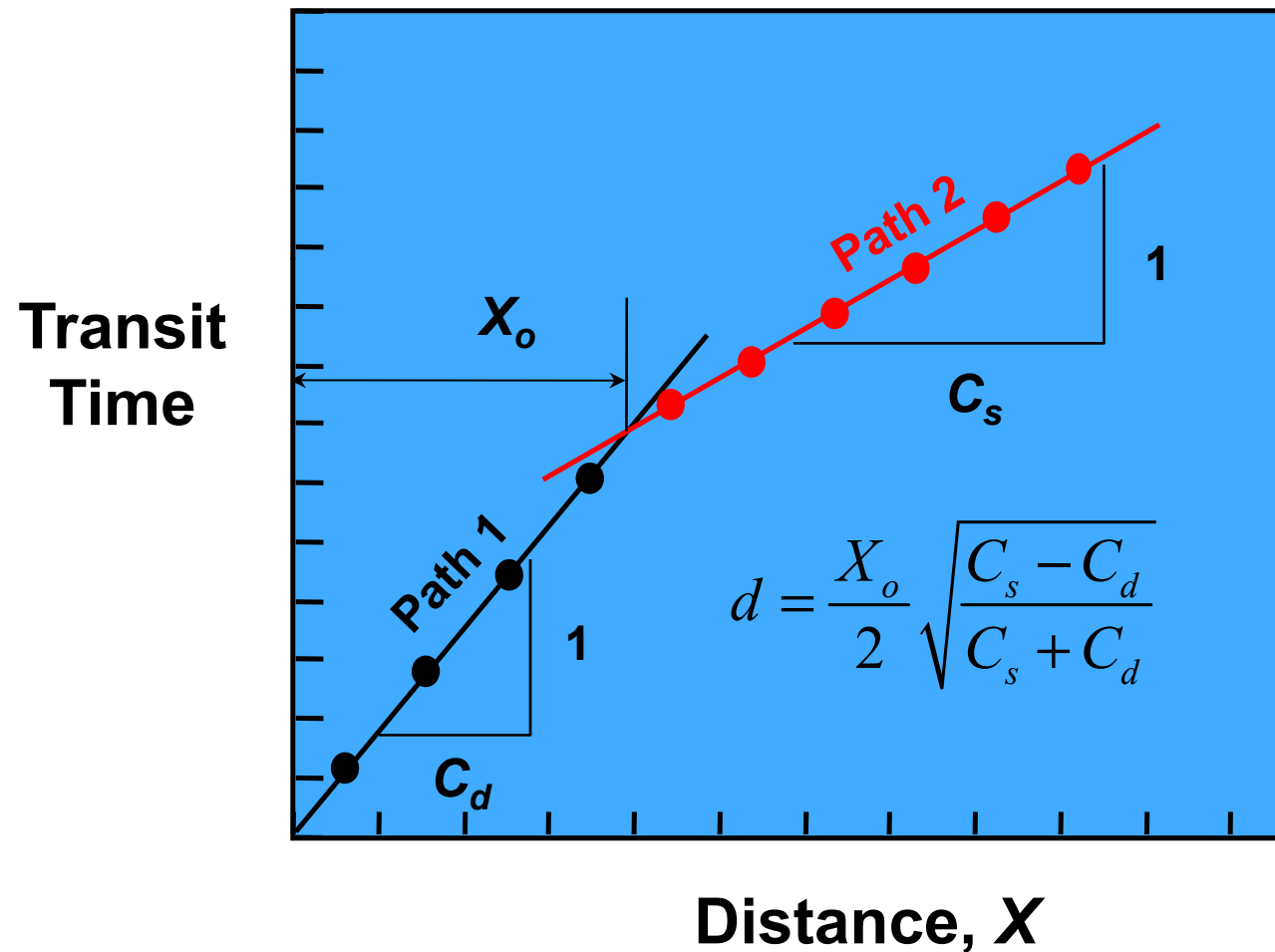

Chung and Law, *Cement Concrete and Aggregates*, 7(2), 1985, 84-88



Tests of Uniformity

- Rebound number
 - ◆ Fast and simple to use
 - ◆ Assesses surface condition
- Pulse velocity
 - ◆ Relatively simple to use
 - ◆ Assess concrete between transducers
 - ◆ Advanced application—depth of surface damage (fire)



In-Place Strength

- Common method: drill cores according to ASTM C42/C42M and test according to ASTM C39/C39M
 - ◆ Requires at least 3.7 in. diameter and length
 - ◆ No reinforcing steel in core
- Post-installed pullout test (CAPO)
 - ◆ Estimate compressive strength based on correlation
- Pull-off test
 - ◆ Direct tensile strength



Pullout Test ASTM C900

Measure force to pullout an insert anchored in concrete.

- ◆ Cast-in-place (CIP): attached to formwork or inserted into top surface of freshly cast slab (during construction)
- ◆ Post-installed (PI); placed into drilled hole with undercut slot (existing construction)

CIP-Pullout Test

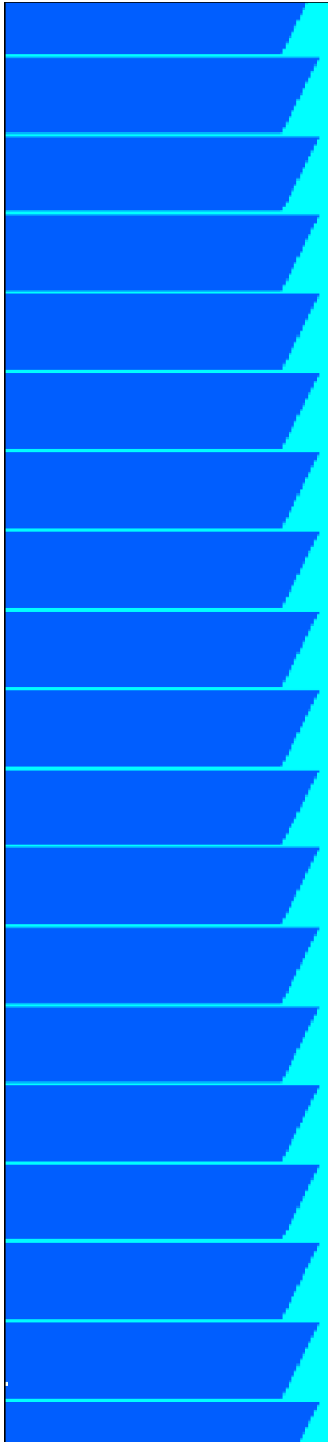
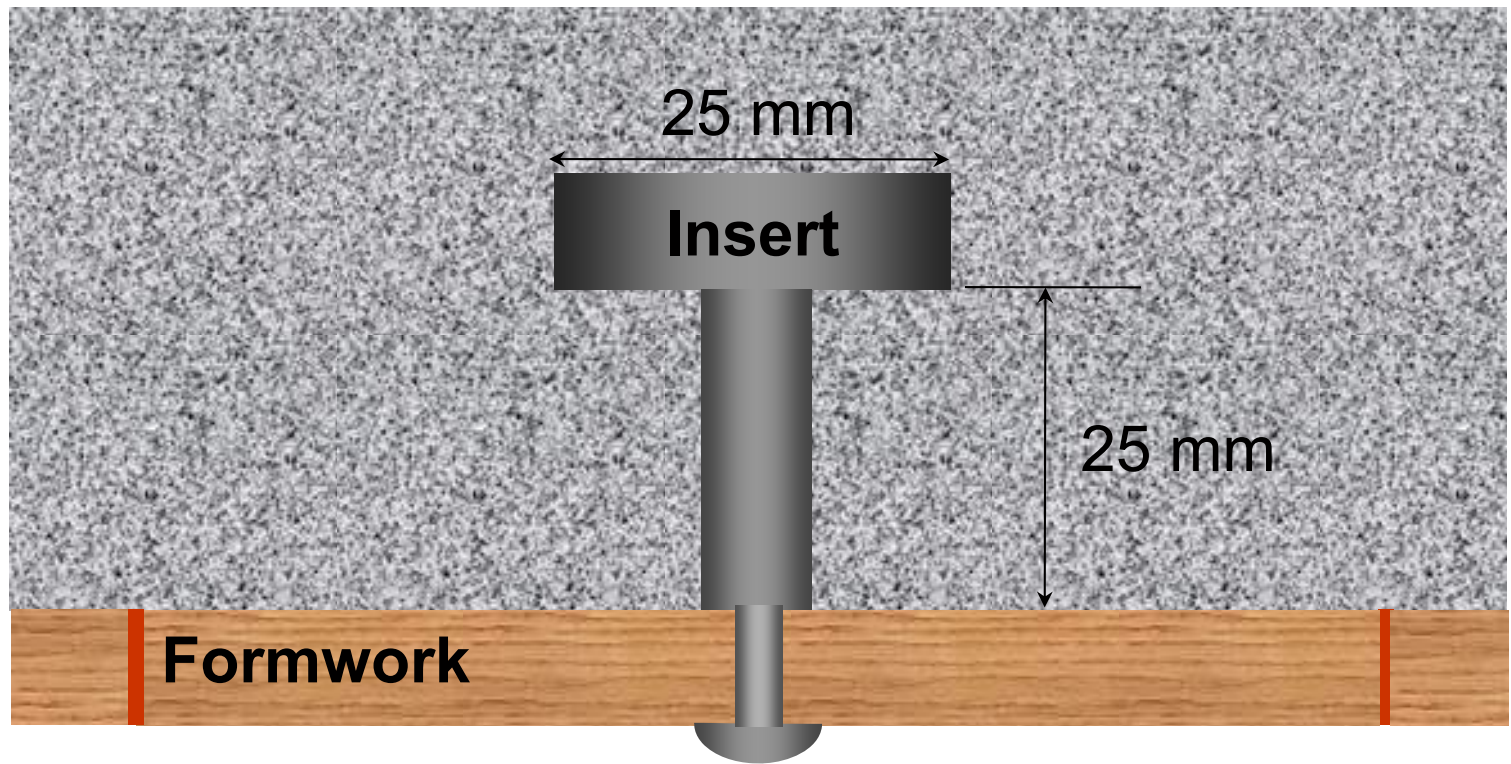

CIP-Pullout Test

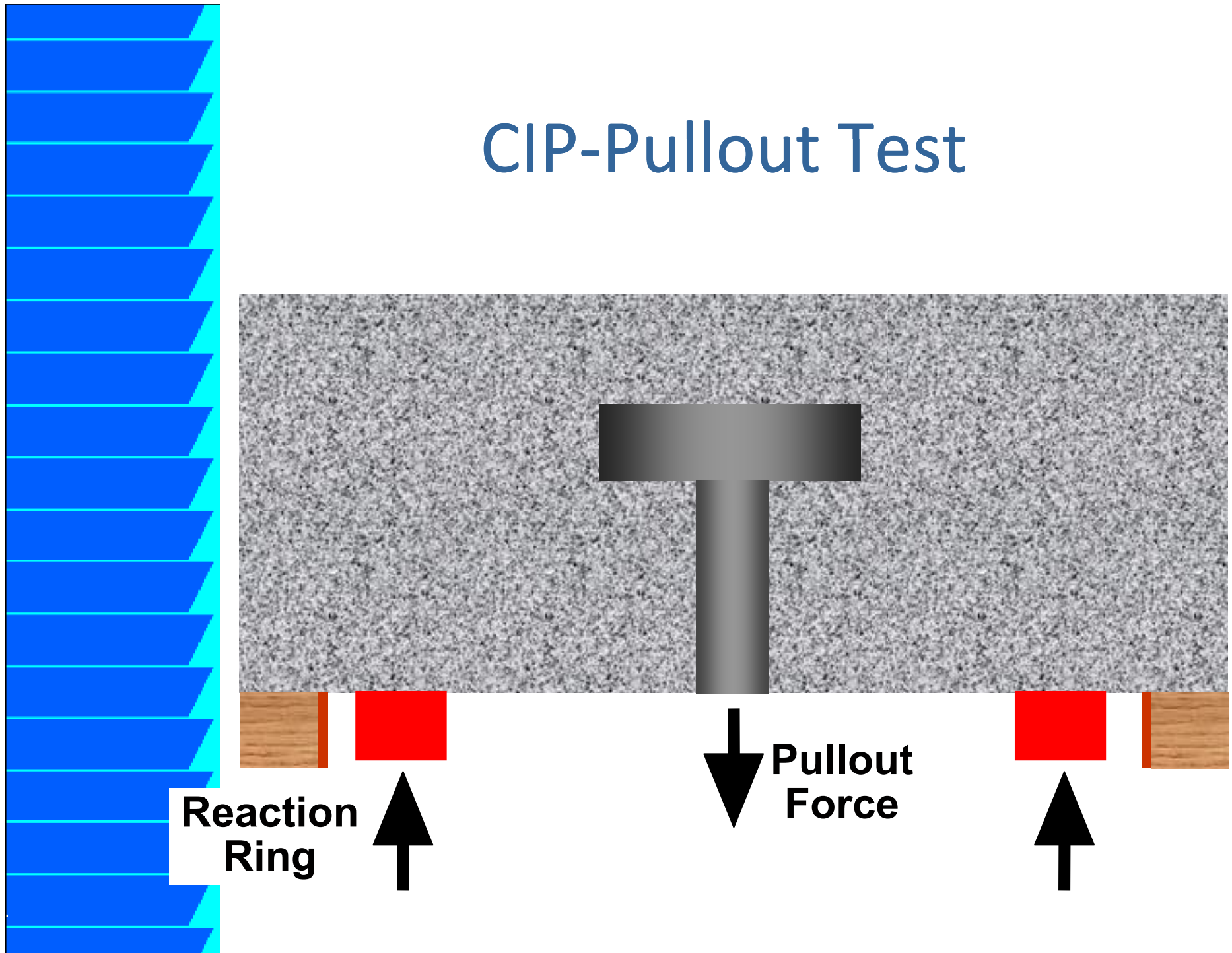

CIP-Pullout Test

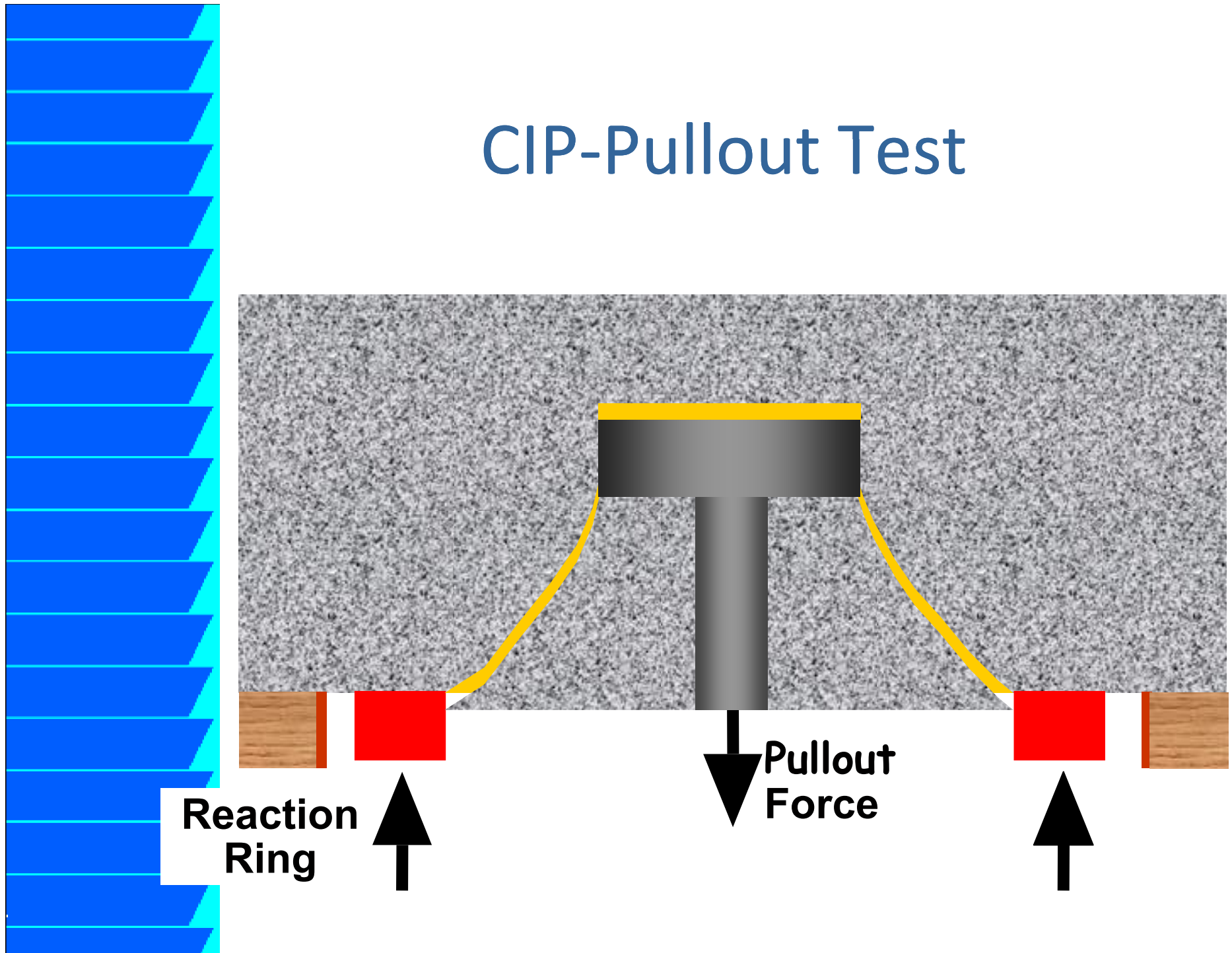

Pullout Test-LOK Test



Pull Machine

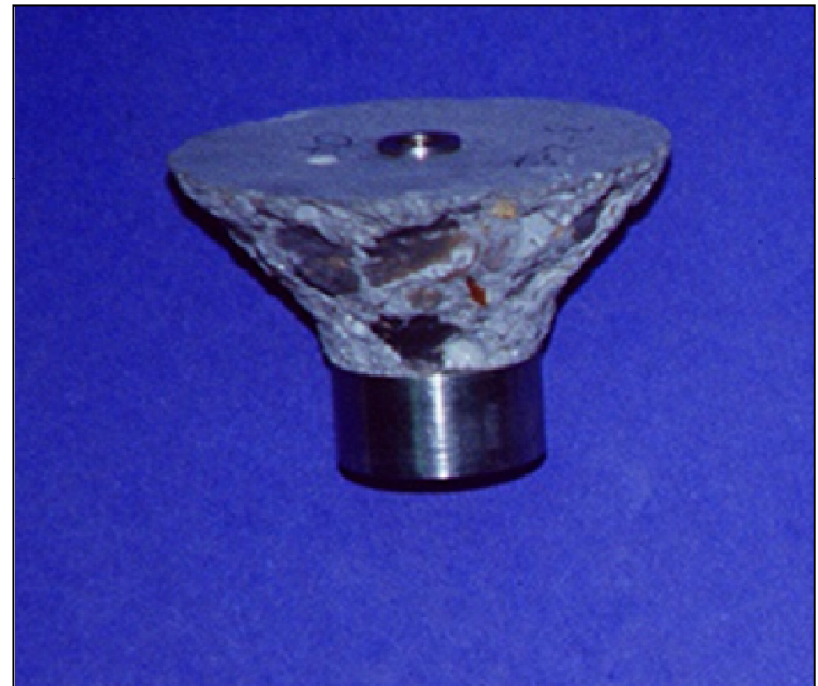

Conical Fragment

Results of 16 Correlations

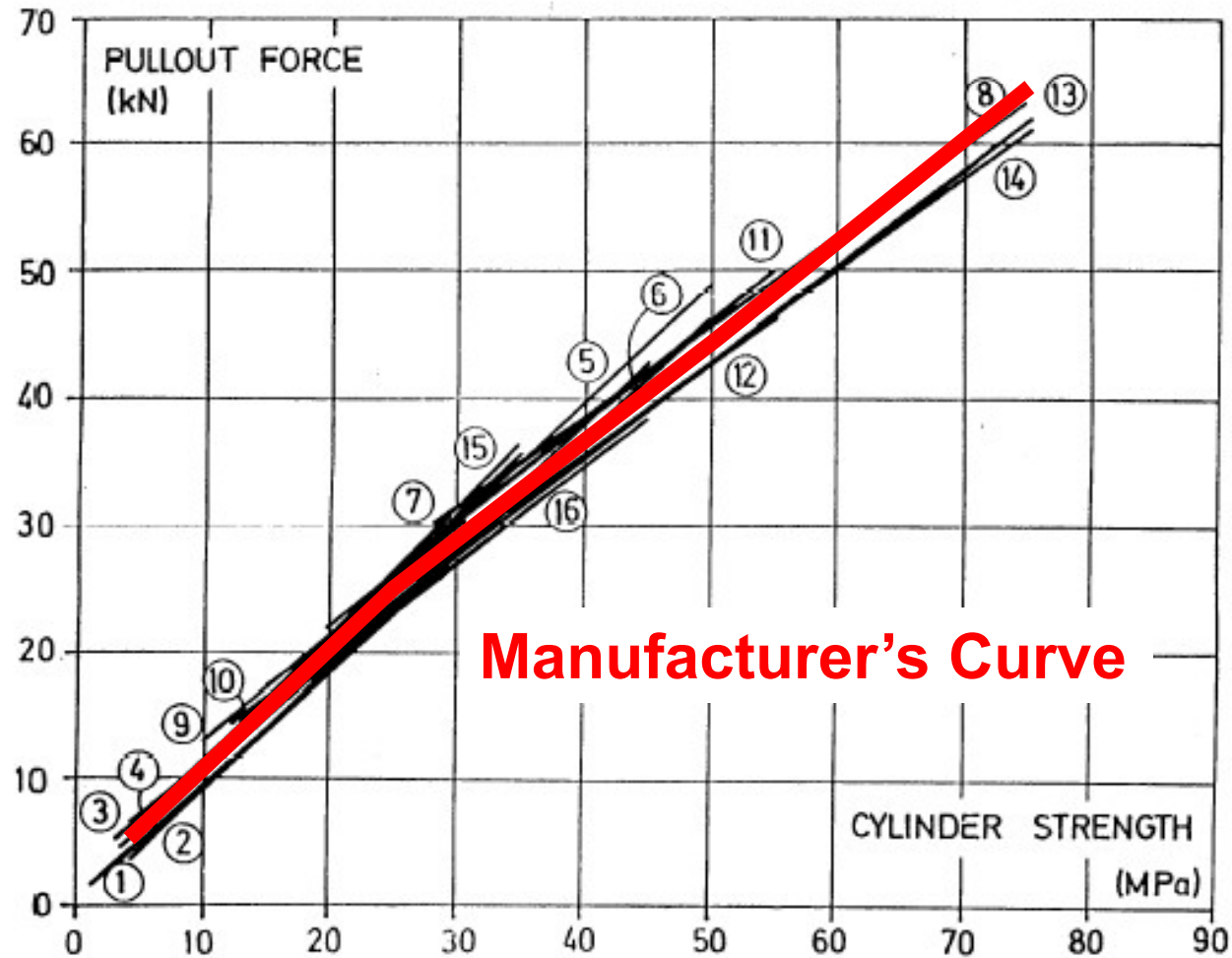



Post-Installed Tests

- Does not require pre-planning test locations
- Can perform test at any accessible location
- Permits testing of existing structures

Post-Installed Pullout Test CAPO Test

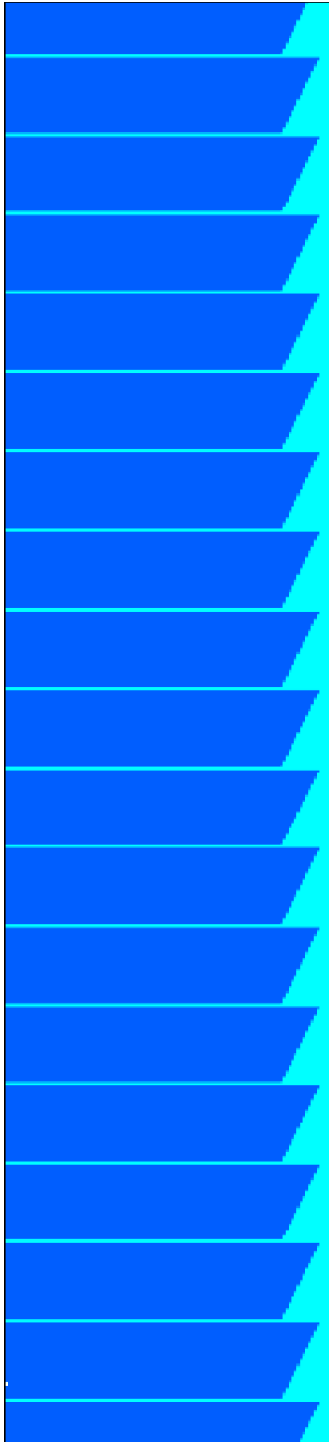
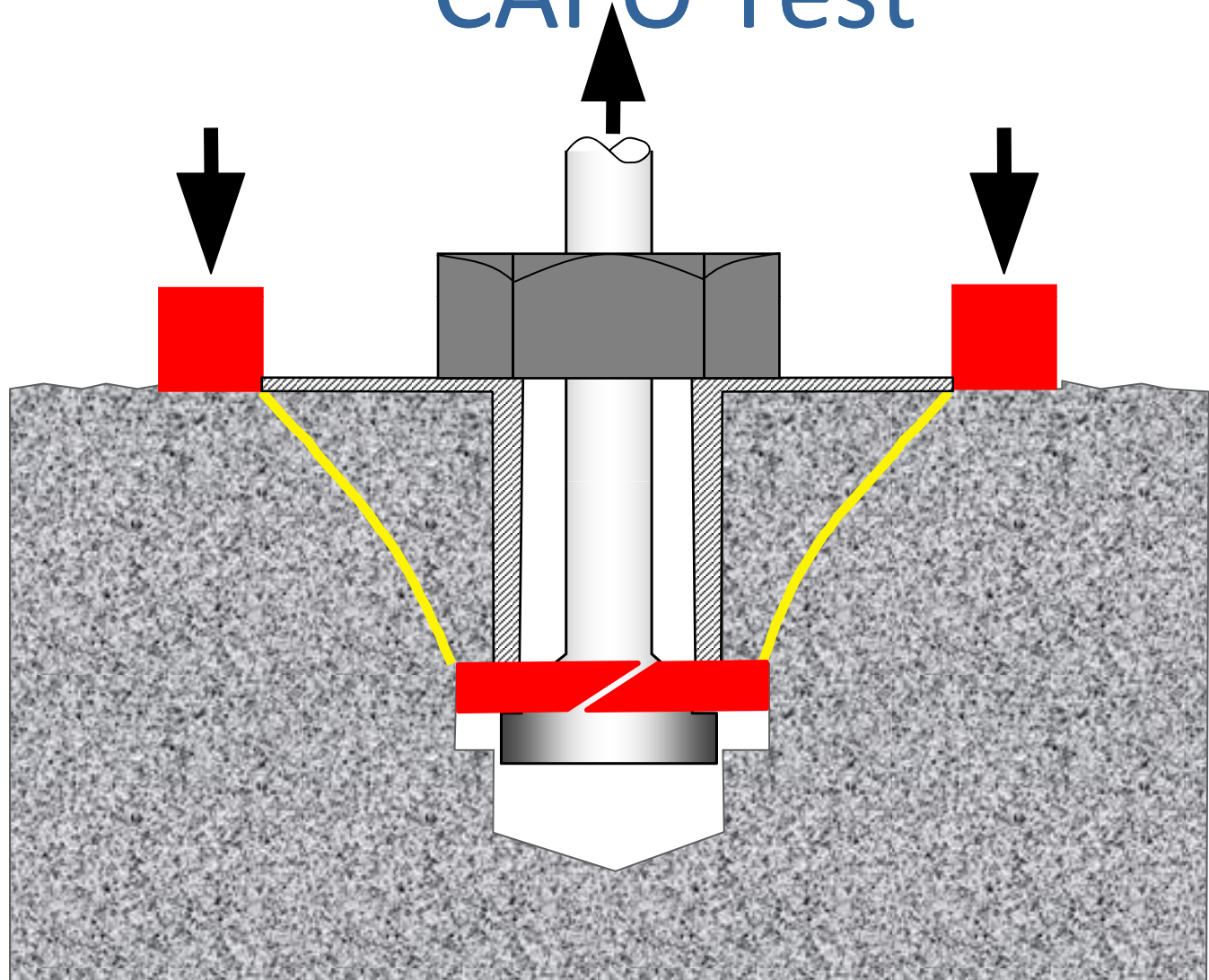

Prepare Concrete

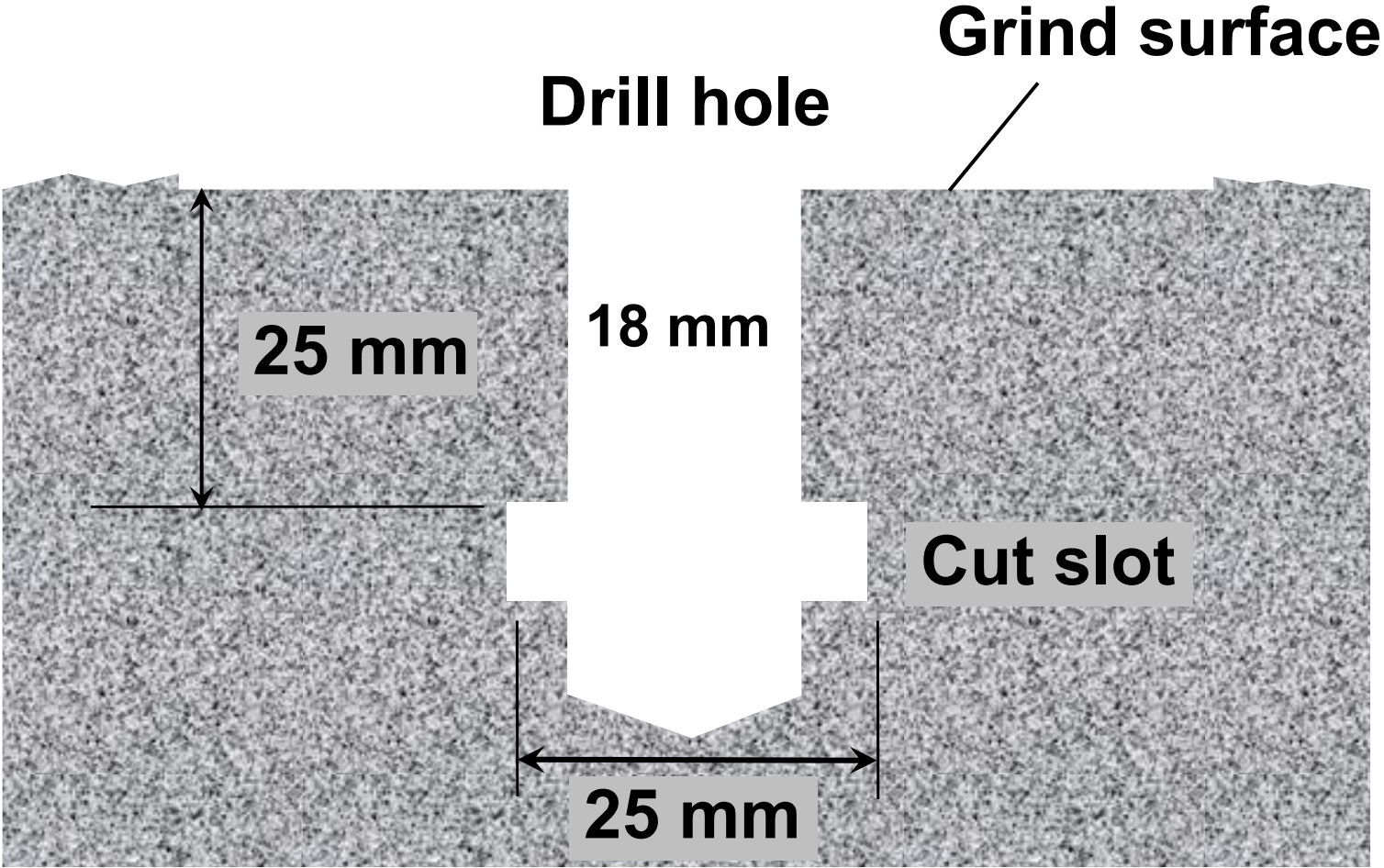

Drill Hole



Surface Planing





Cut Slot

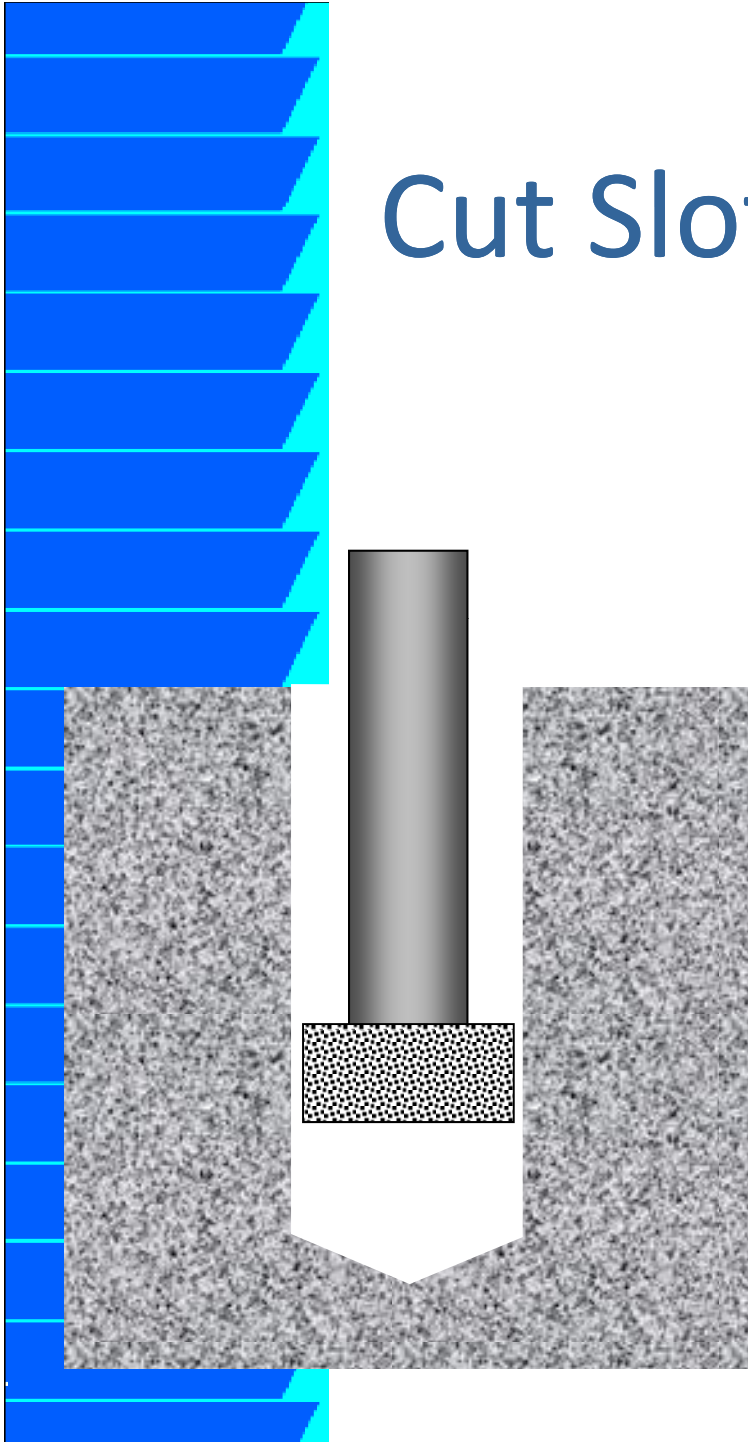

Cut Slot

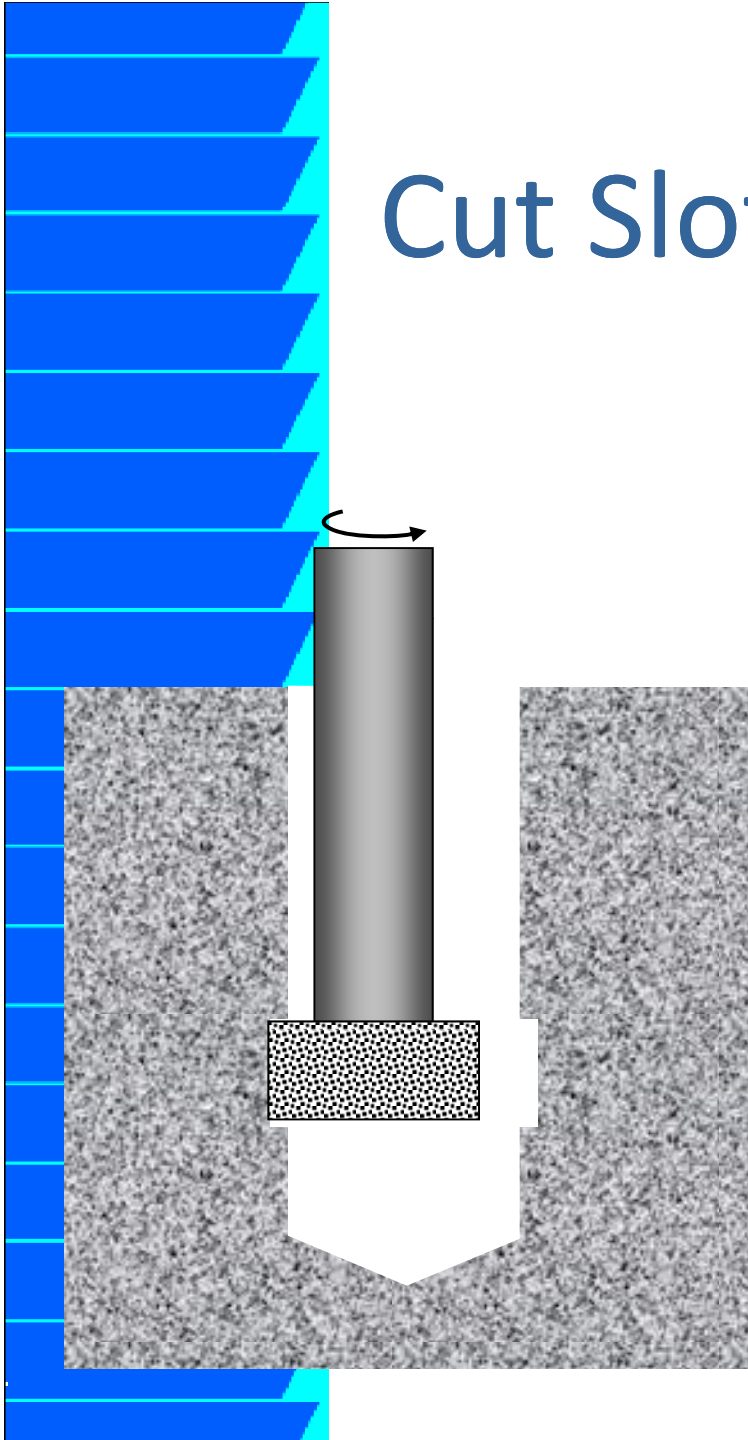

Cut Slot

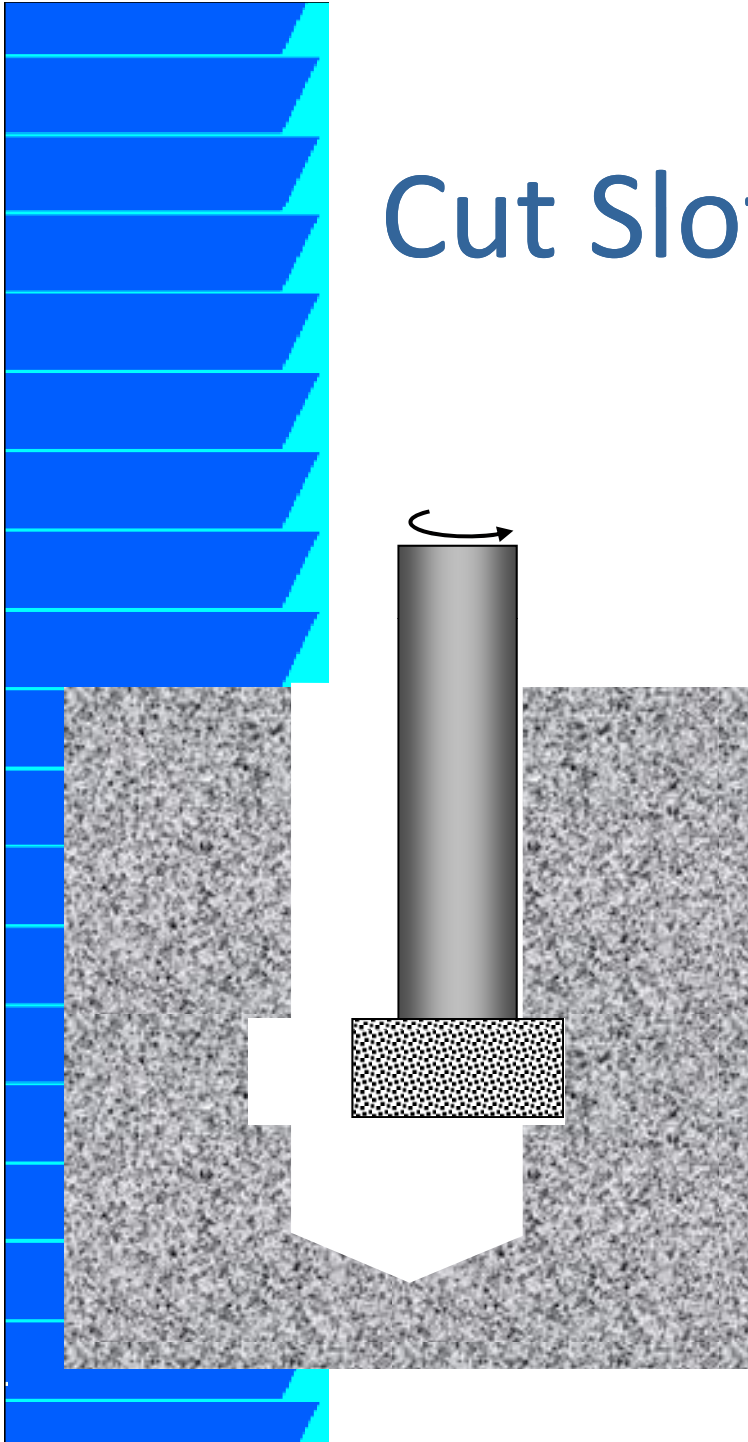

Insert Expansion Cone and Coiled Ring

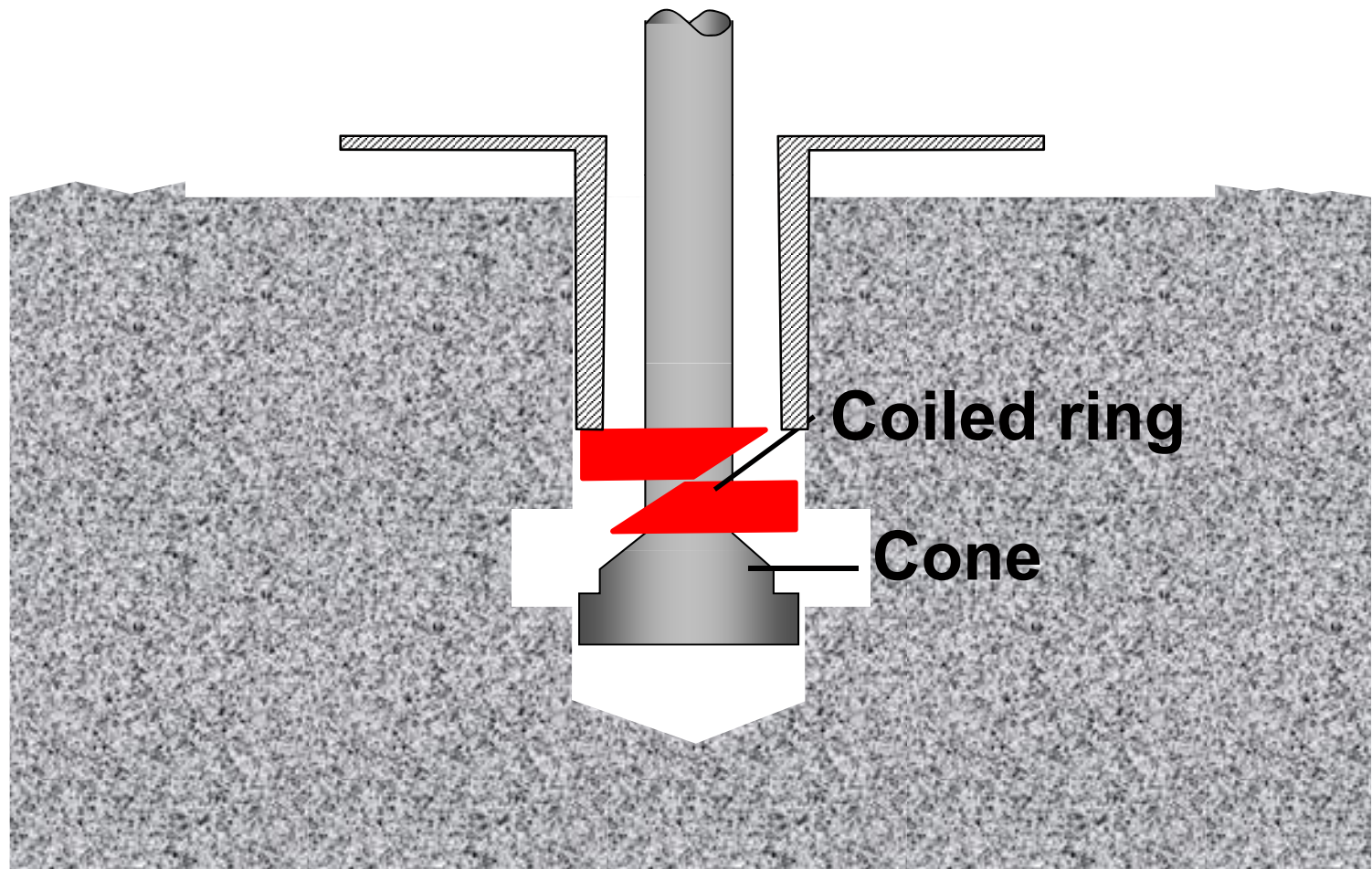

Ring Expansion Hardware

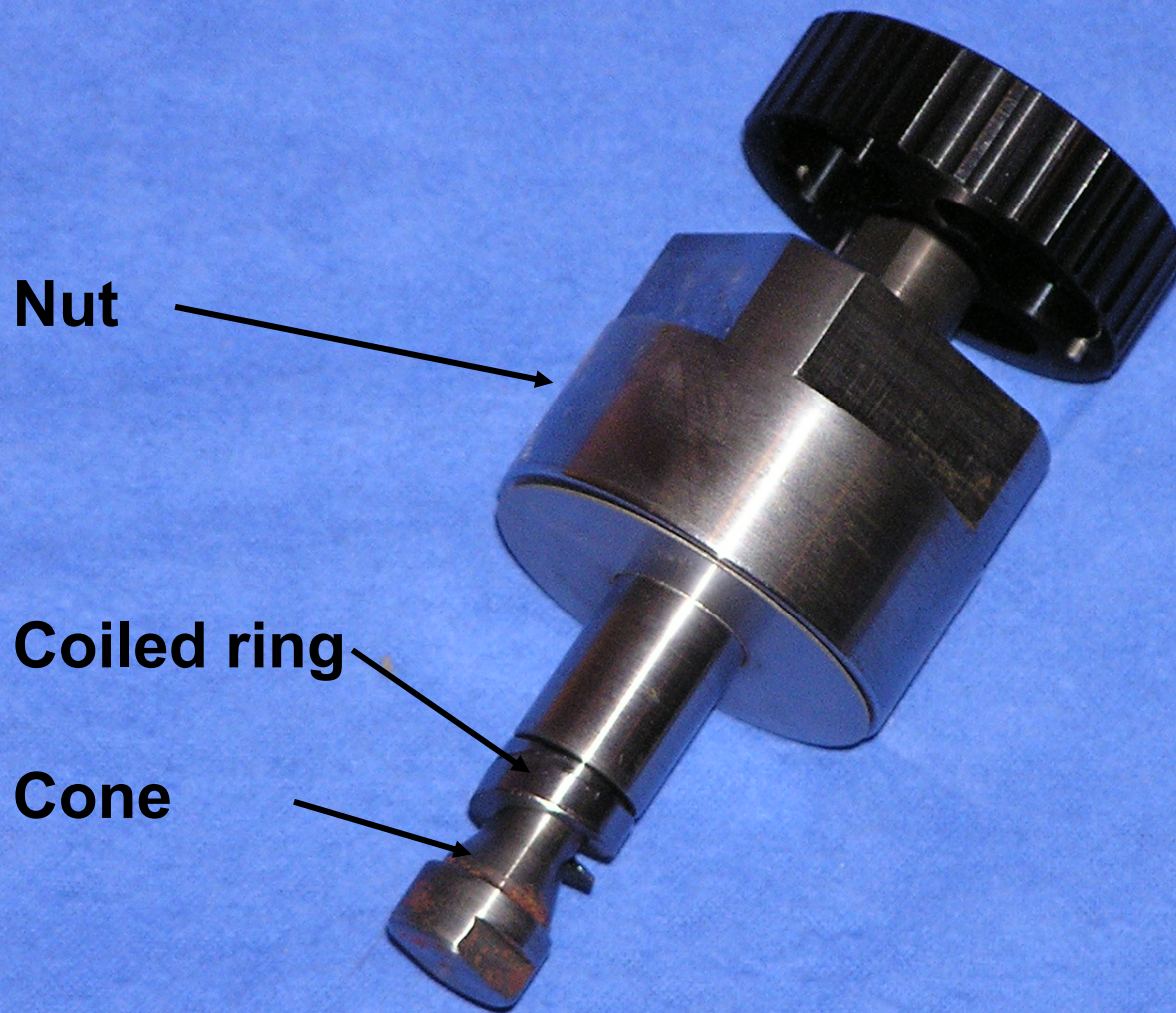

Expand Ring

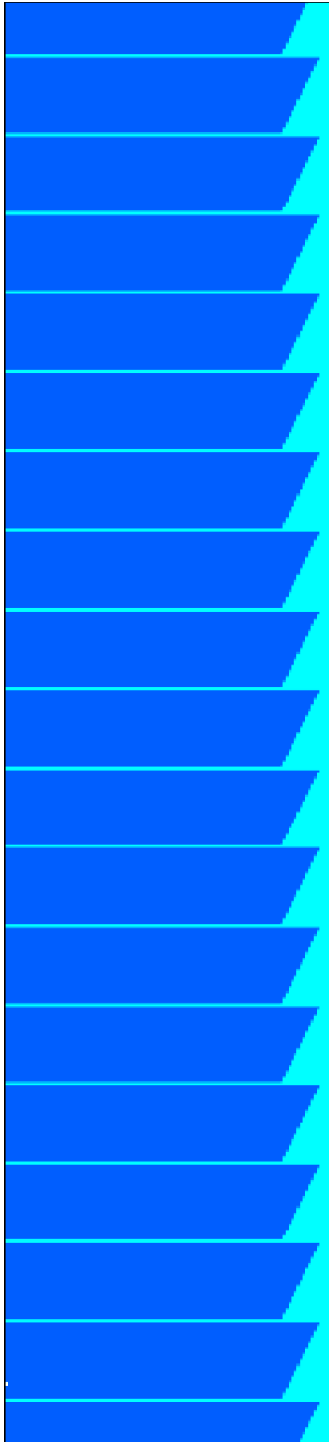
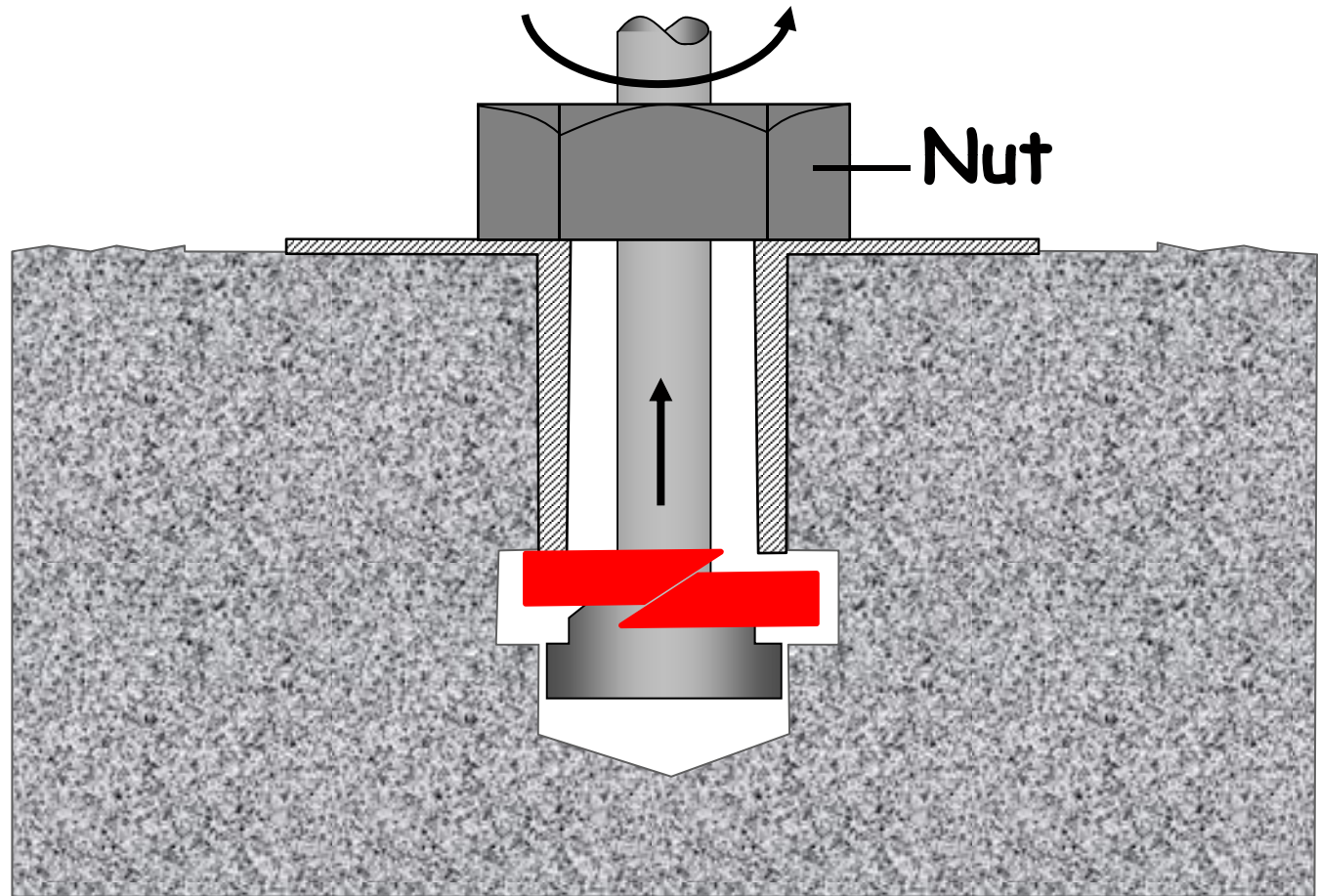

Expand Ring



Pullout the Expanded Ring

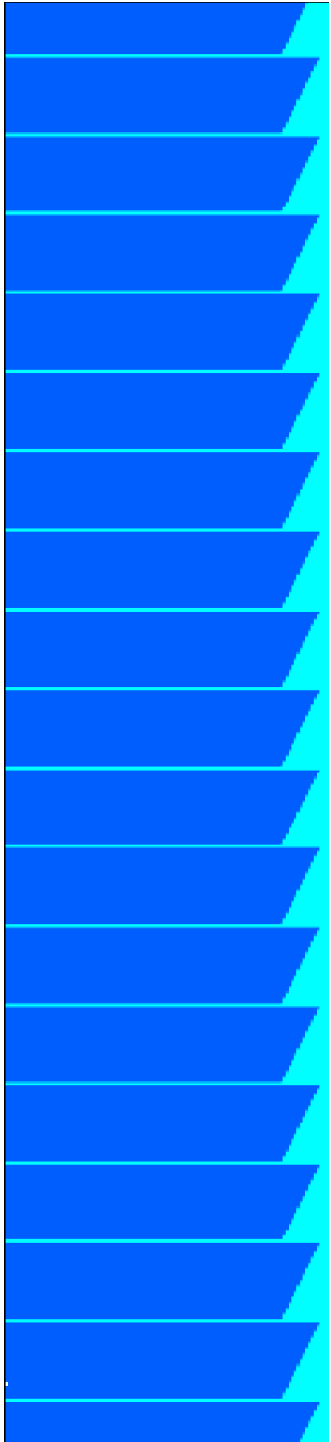
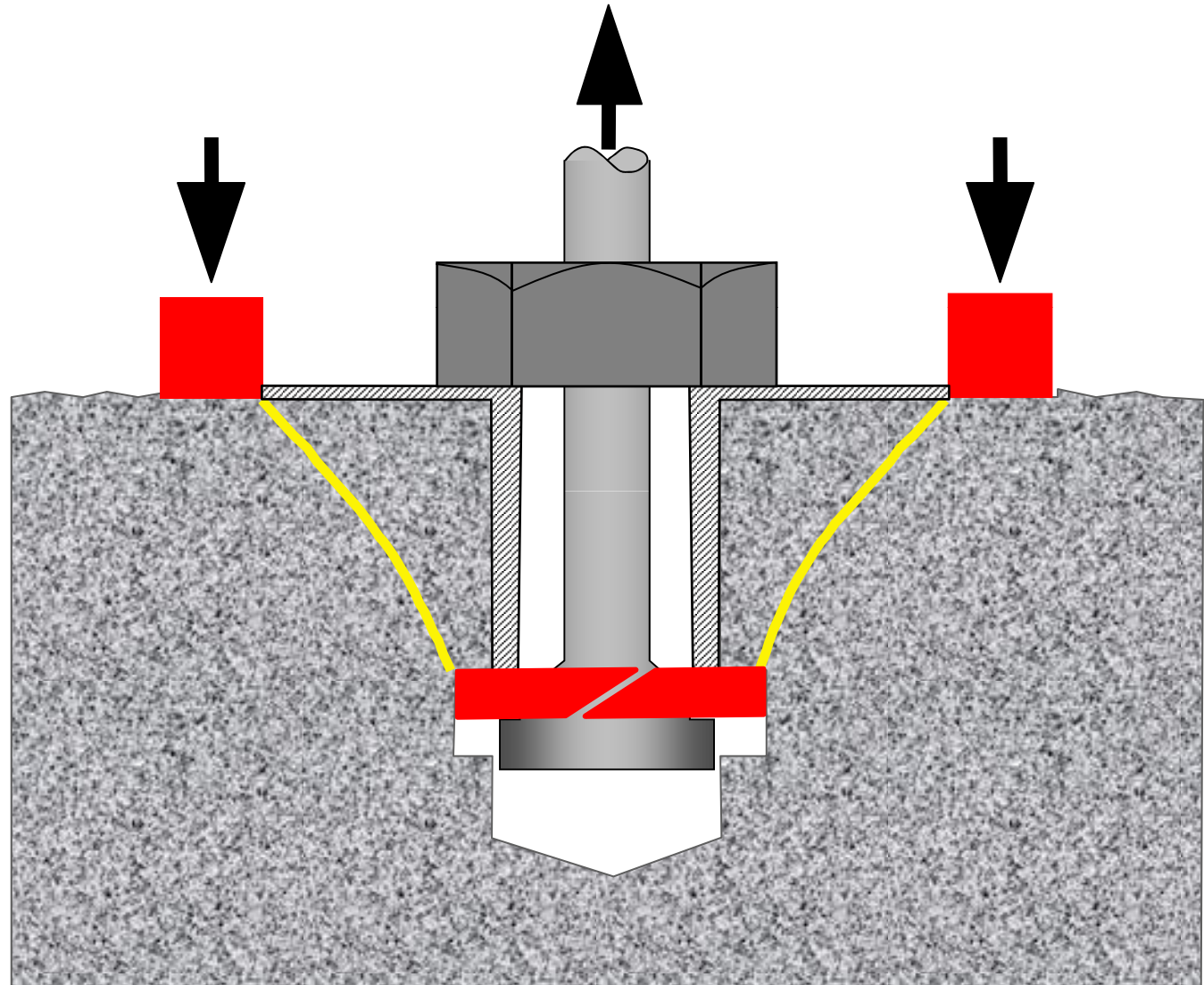

Apply
Pullout
Force



CAPO-Test vs LOK-Test

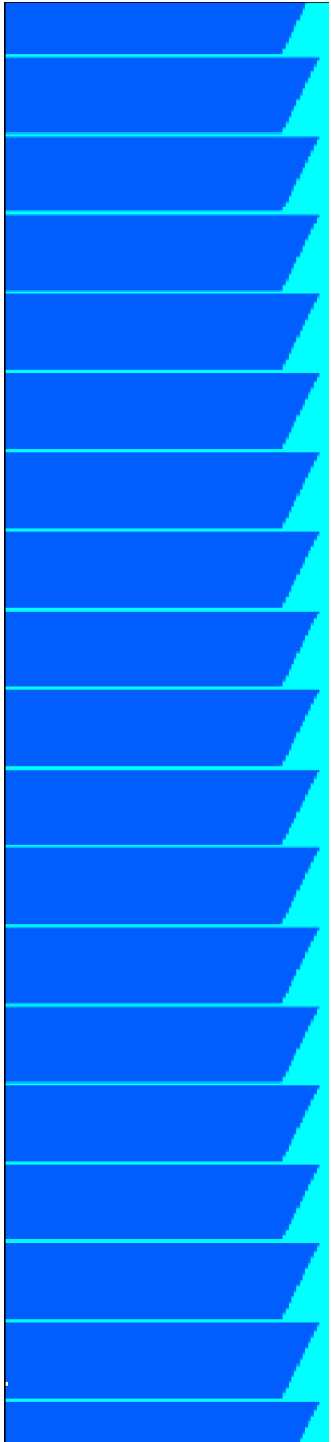
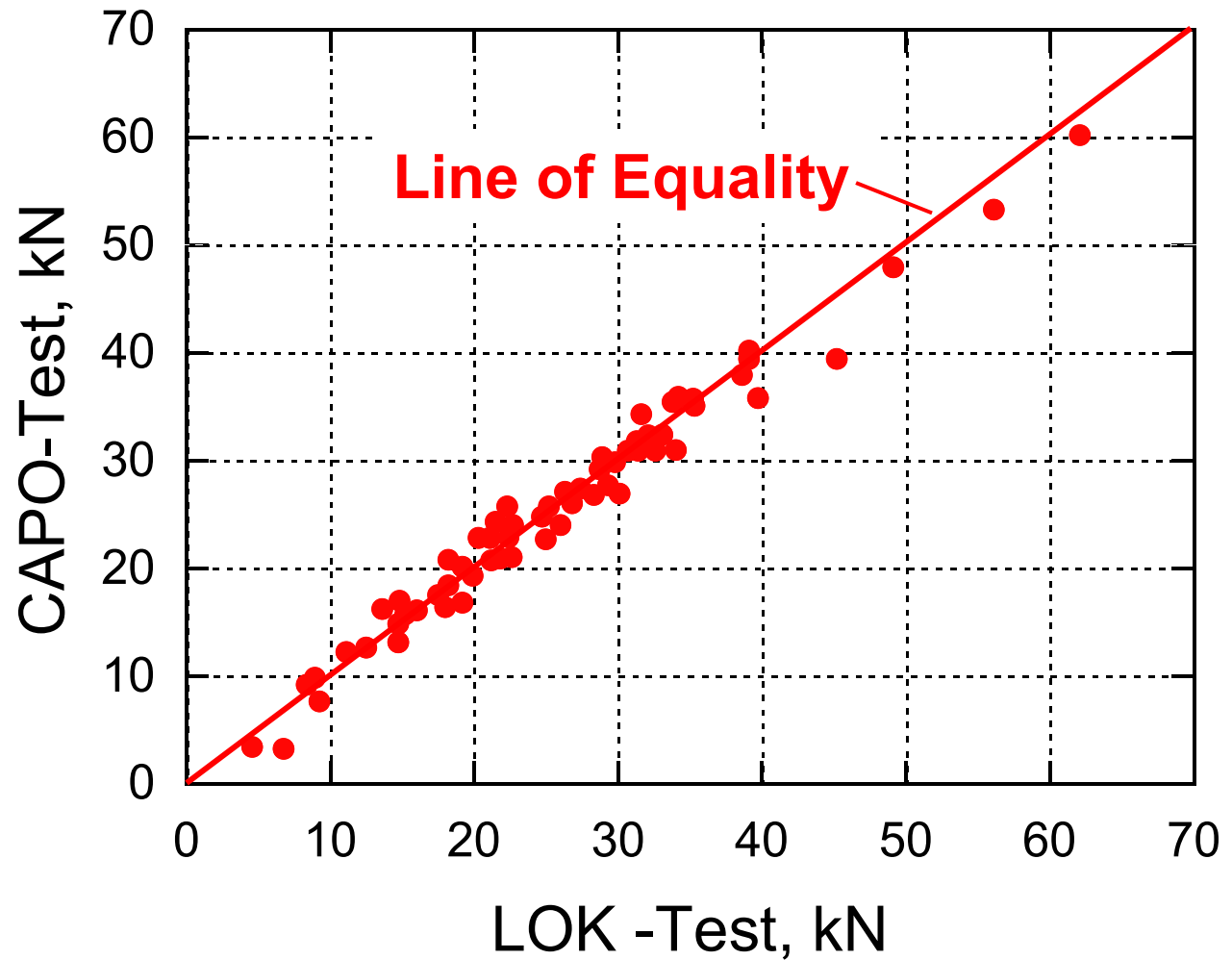



Pull-off Test ASTM C1583

Measure force required to pull off a metal disc bonded to concrete surface.



Pull-off Test

- Direct tensile strength test
- Evaluate condition of concrete surface before application of overlay or repair material
- Measure bond strength of overlay or surface repair materials

Pull-off Test

- Bond metal disc to surface
- Drill partial core
- Apply tensile force

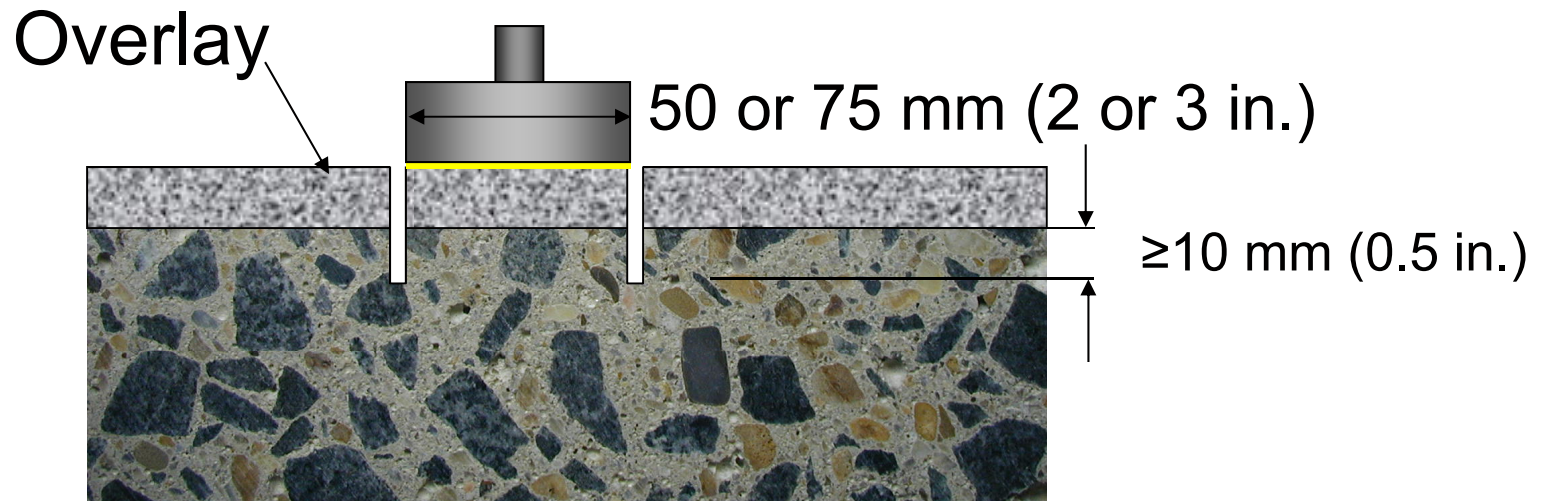

Pull-off Test

- Bond metal disc to surface
- Drill partial core
- Apply tensile force

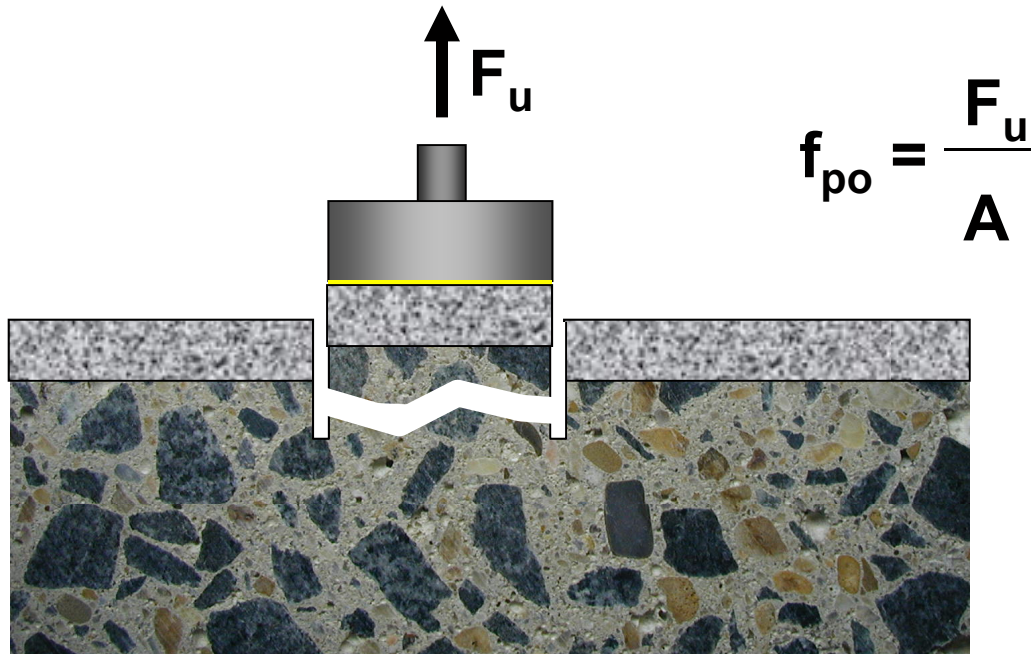

Schematic of Apparatus ASTM C1583

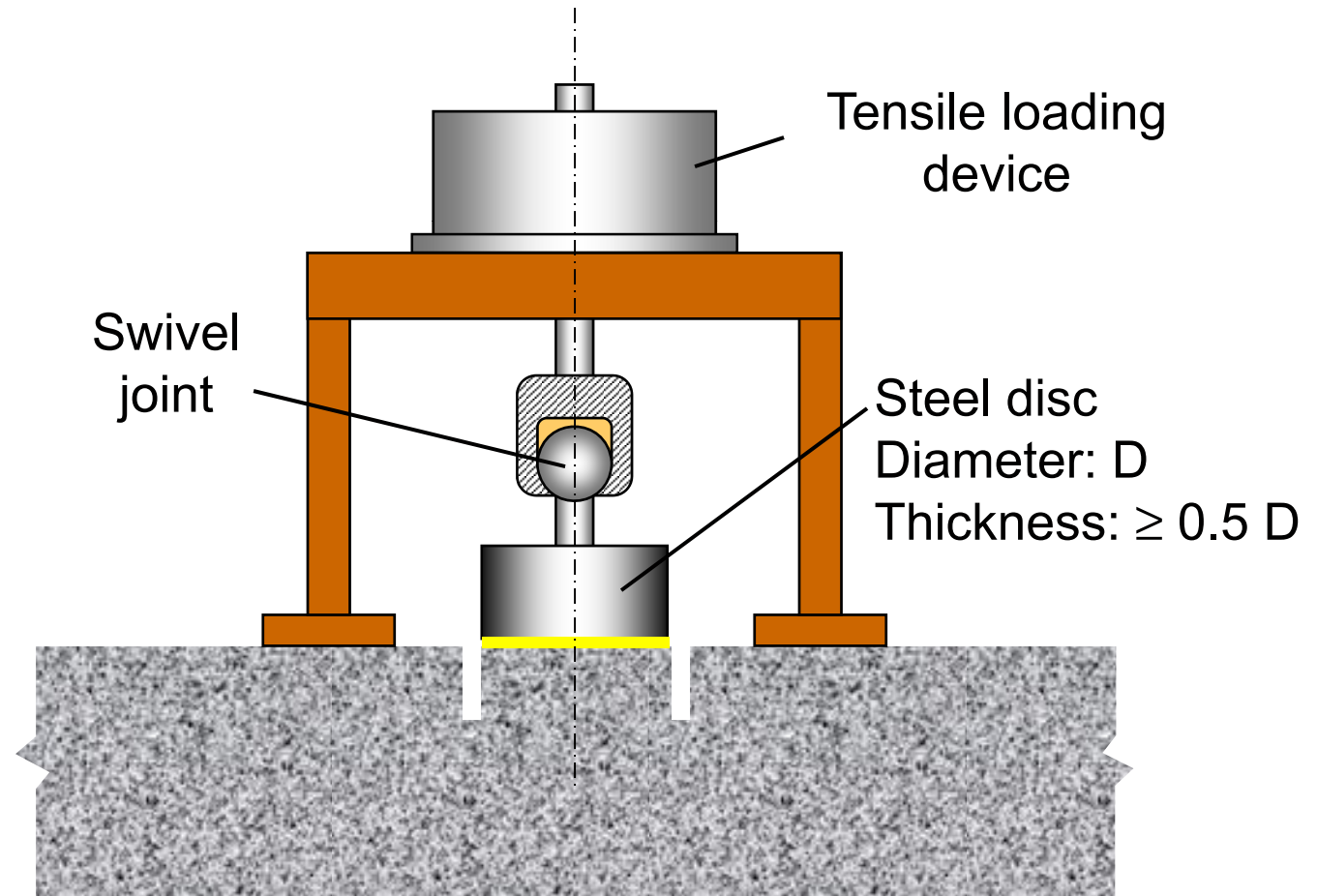

Pull-off Test Apparatus

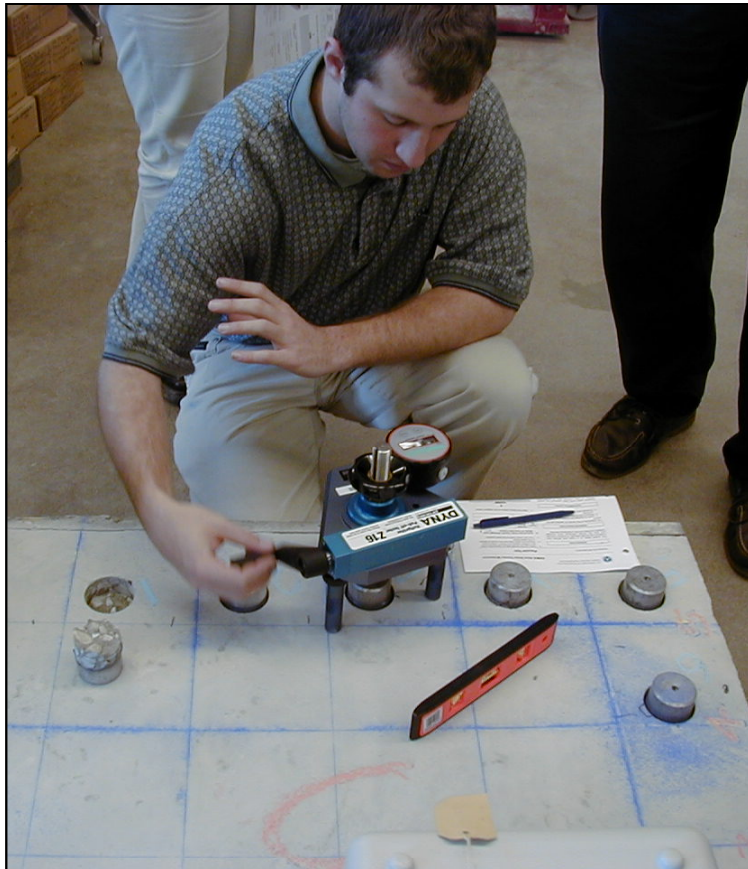

Proceq



Germann Instruments

Pull-off Test Failure Locations

- Interfacial bond failure (bond strength)

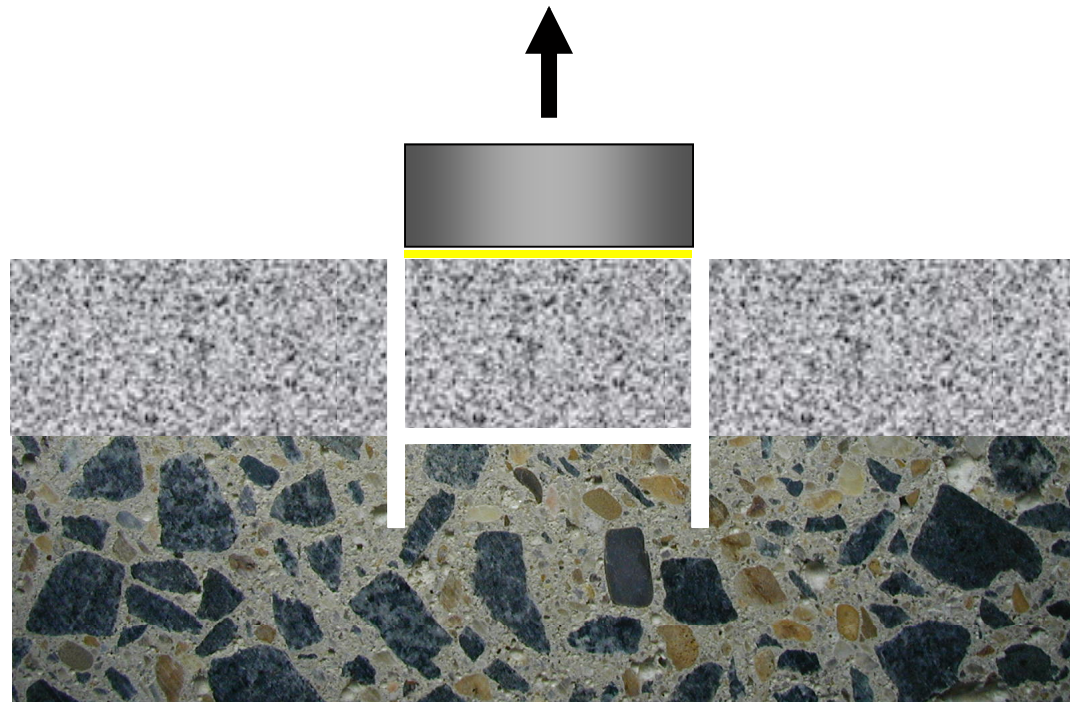

Pull-off Test Failure Locations

- Cohesive failure in the existing concrete (substrate strength)

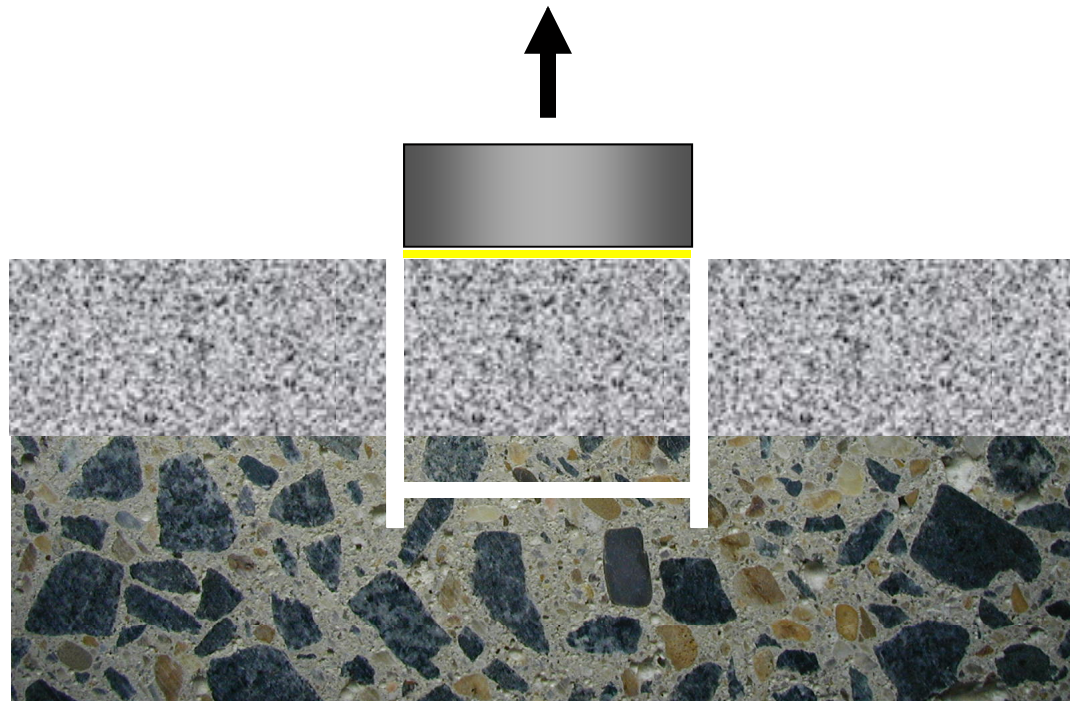

Pull-off Test Failure Locations

- Cohesive failure in the repair material

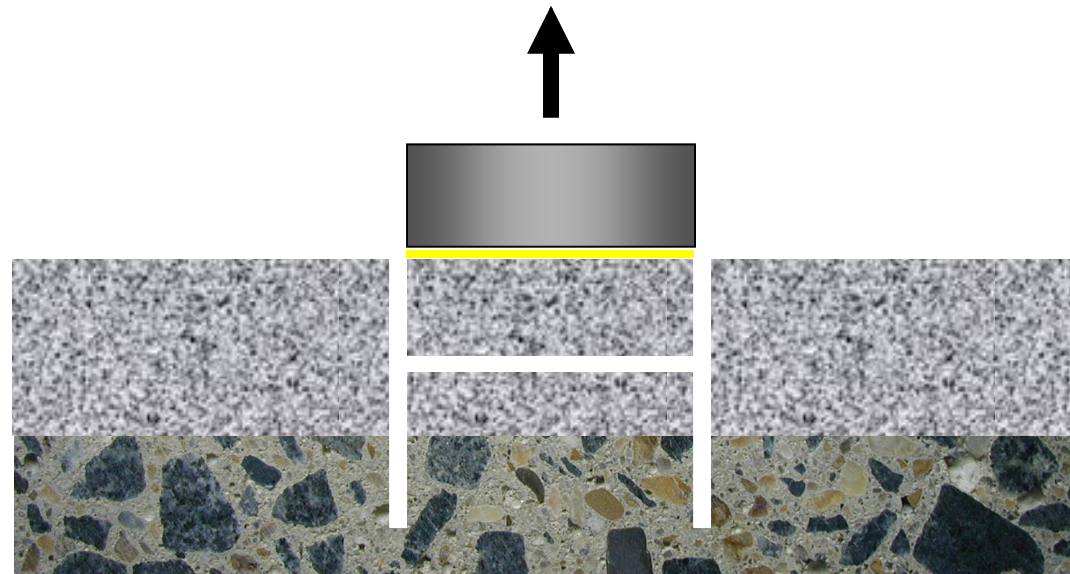

- Can not predict failure location
- Average the results for same failure locations

Pull-off Test Failure Locations

- Bond failure at the adhesive
- Inconclusive test—bond strength is at least failure stress

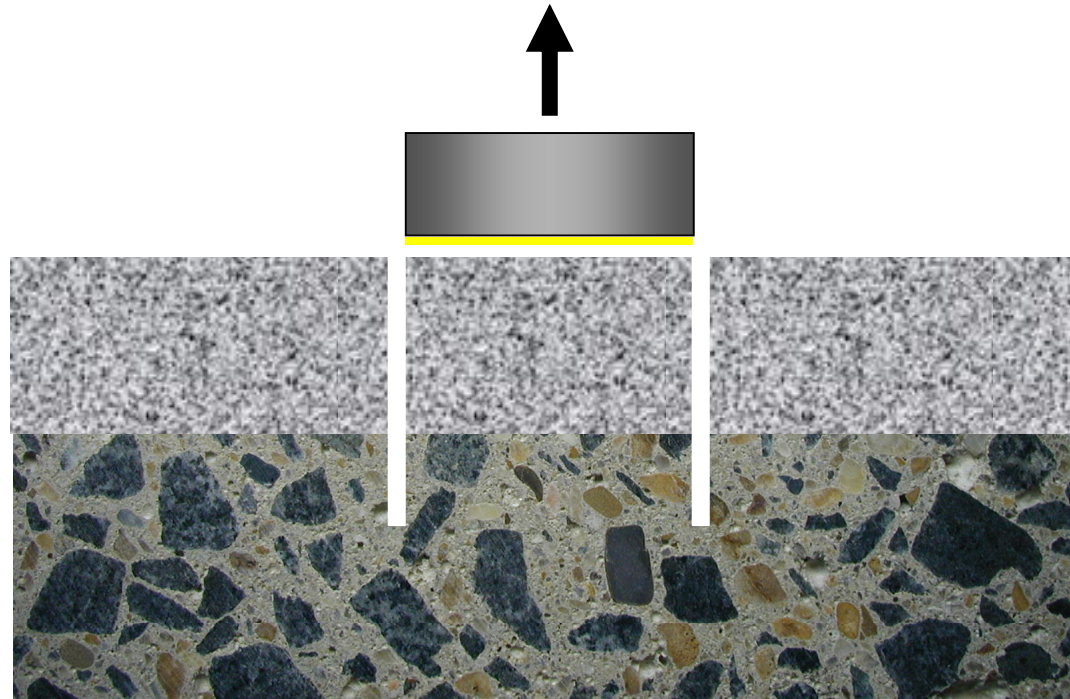

Evaluation of Surface Preparation Methods

- Surfaces to receive overlay or repair material are usually prepared to ensure good bonding
- Some repair methods can damage concrete and reduce the “apparent” bond strength

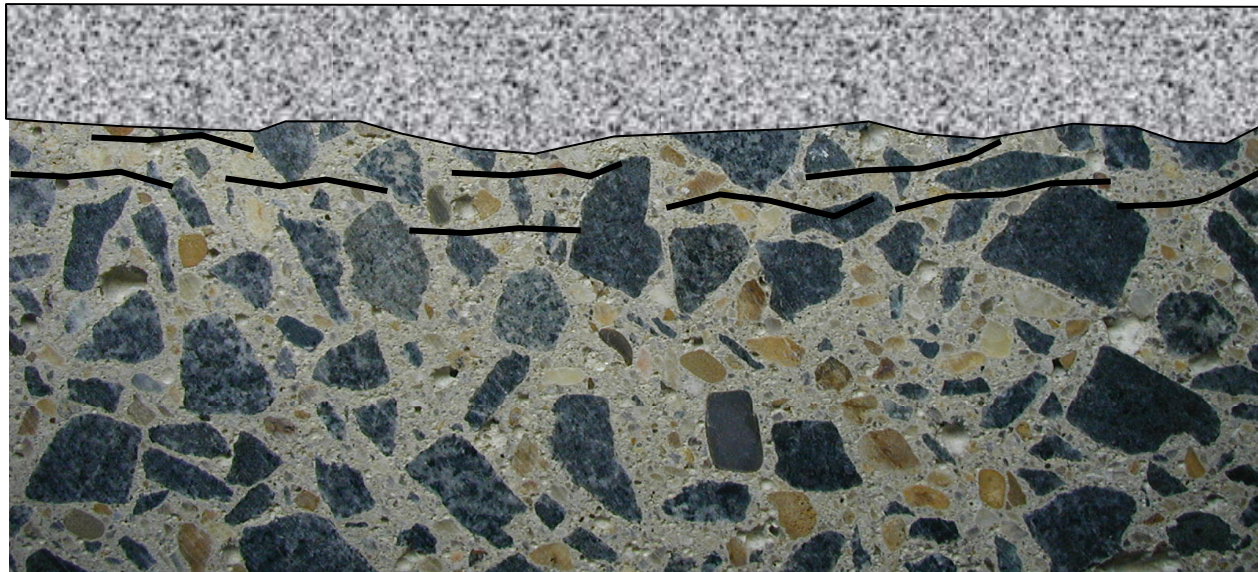

Evaluation of Surface Preparation Methods

- Test substrate before applying overlay
 - ◆ ACI 503R (Use of Epoxy Compounds with Concrete) recommends substrate pull-off strength > 175 psi (1.2 MPa)

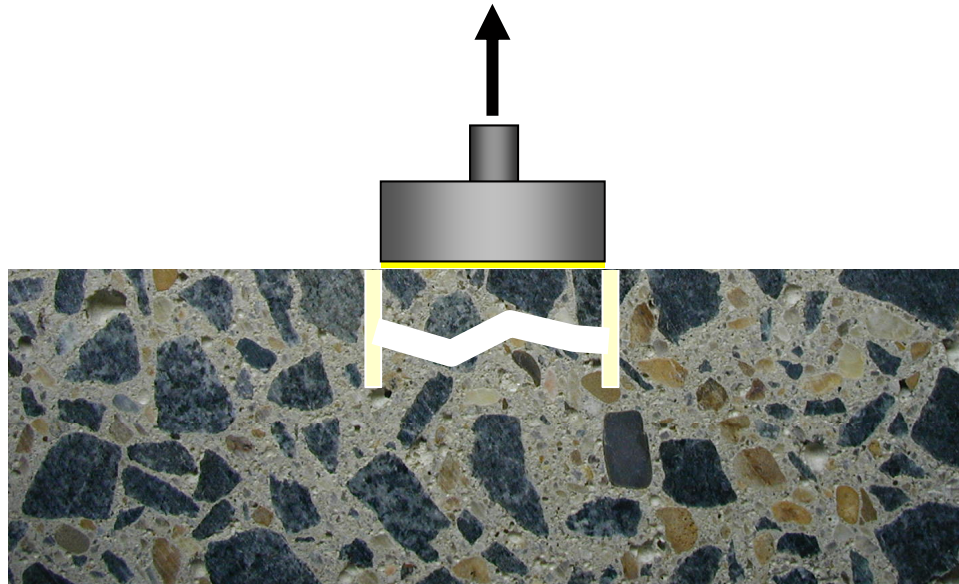

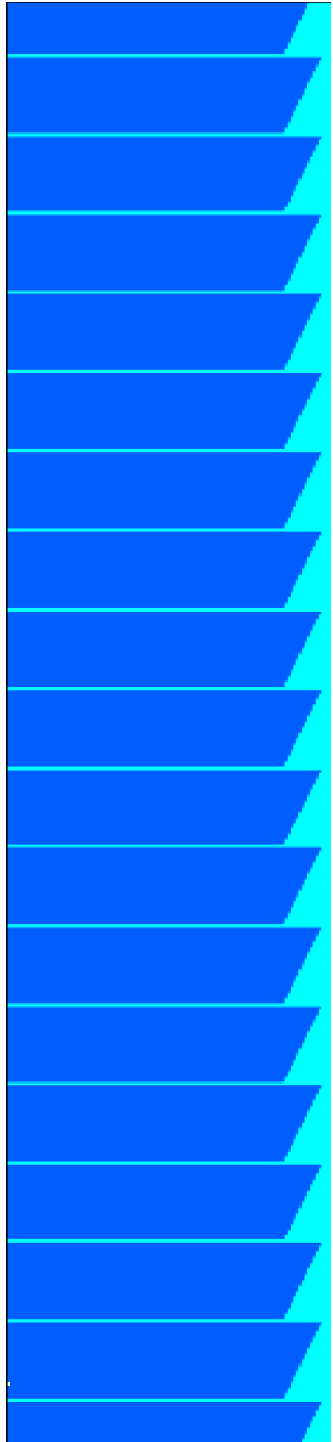

Stretch Break



Flaw Detection

- Voids (e.g., in tendon ducts)
- Honeycombing (poor consolidation)
- Delaminations
- Thickness of members
- Corrosion of reinforcement



Stress-Wave Methods

- A stress wave (sound) is easy to generate
 - ◆ Mechanical impact
 - ◆ Transducers
- Travel speed affected by elastic constants and density of concrete
- Stress wave traveling through a solid (such as concrete) is reflected at an air interface
- Monitoring the arrival of reflected stress wave allows us to “look” into concrete
 - ◆ Defects
 - ◆ Thickness



Outline

- Basic principles of stress wave propagation
 - ◆ Wave types
 - ◆ Reflection
- Ultrasonic pulse velocity
- Sounding (chain drag)
- Impact-echo method
- Impulse-response
- Ultrasonic-echo method

Stress Waves due to Impact

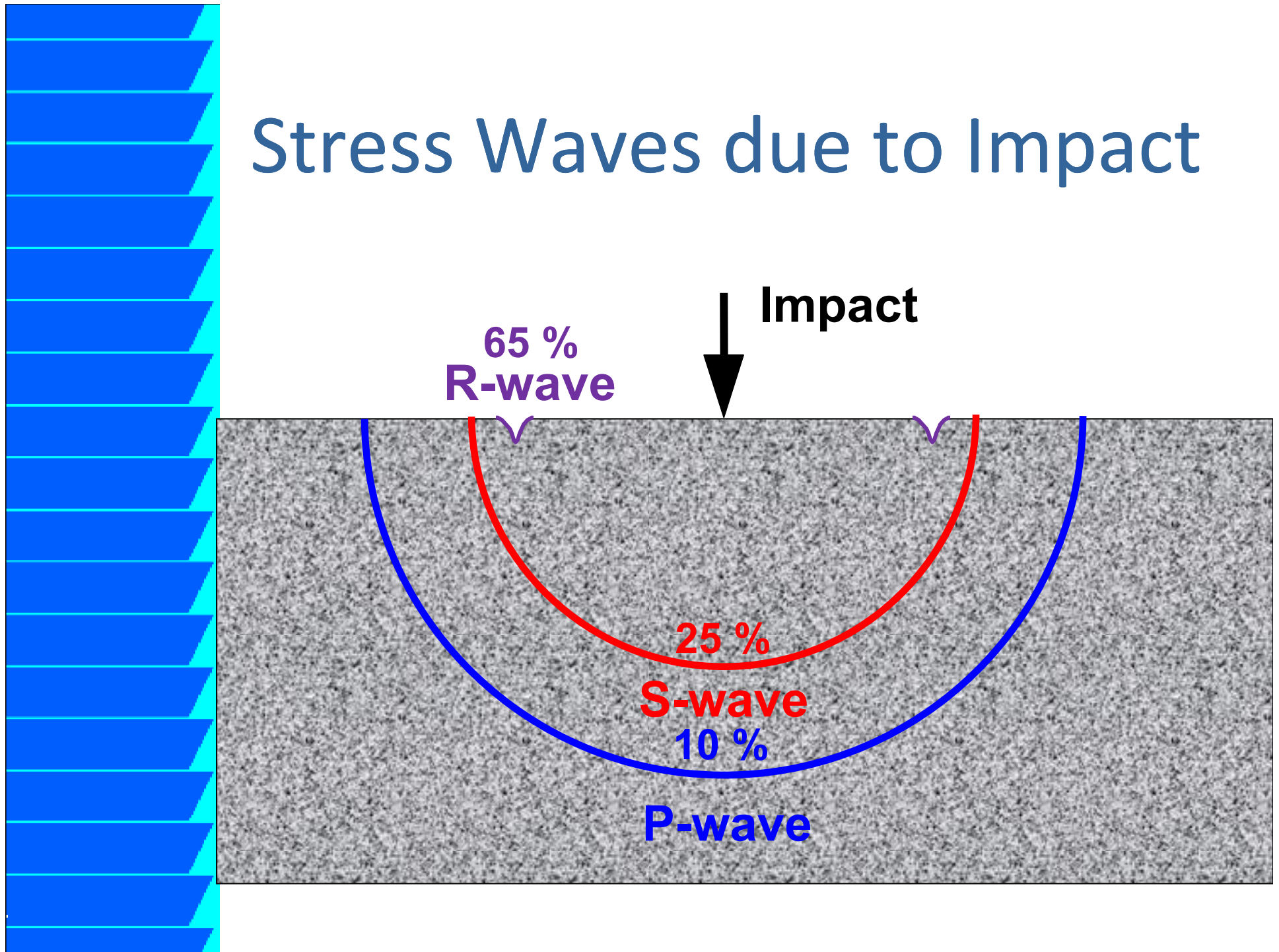



Wave Modes

- P-wave—associated with normal stress
- S-wave—associated with shear stress
- R-wave—combination of normal stress and shear stress
- [WebFiles\wavemotion.html](http://WebFiles/wavemotion.html)

Summary of Wave Modes

Particle Motion

Wave Speed

P-Wave

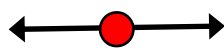

$$C_P = \sqrt{\frac{E(1-\nu)}{\rho(1+\nu)(1-2\nu)}}$$

S-Wave



$$C_S = \sqrt{\frac{G}{\rho}}$$

R-Wave

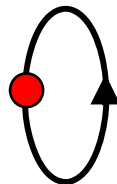

$$C_R = C_S \frac{0.87 + 1.2\nu}{1 + \nu}$$

Wave Propagation Direction 

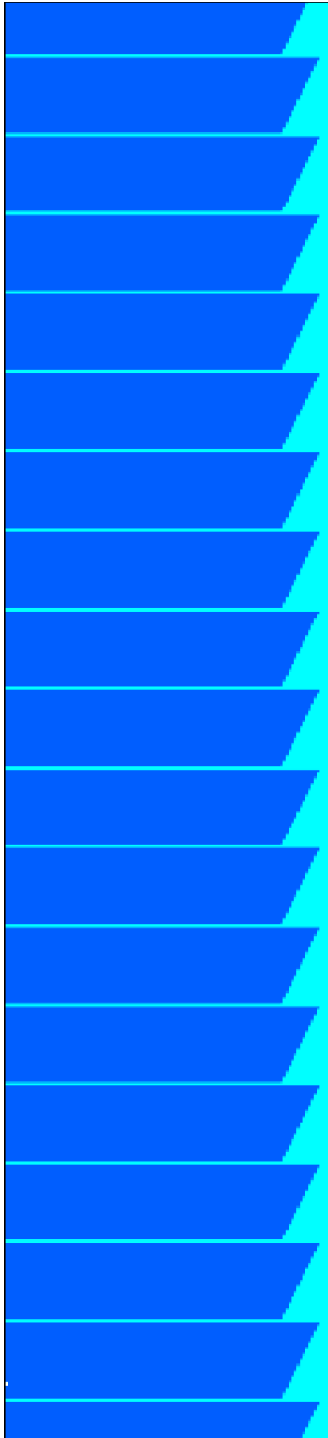



Relative Wave Speeds

($\nu = 0.2$)

P-Wave **$C_p = 1$**

S-Wave **$C_s = 0.62 C_p$**

R-Wave **$C_R = 0.56 C_p$**

Reflection and Refraction

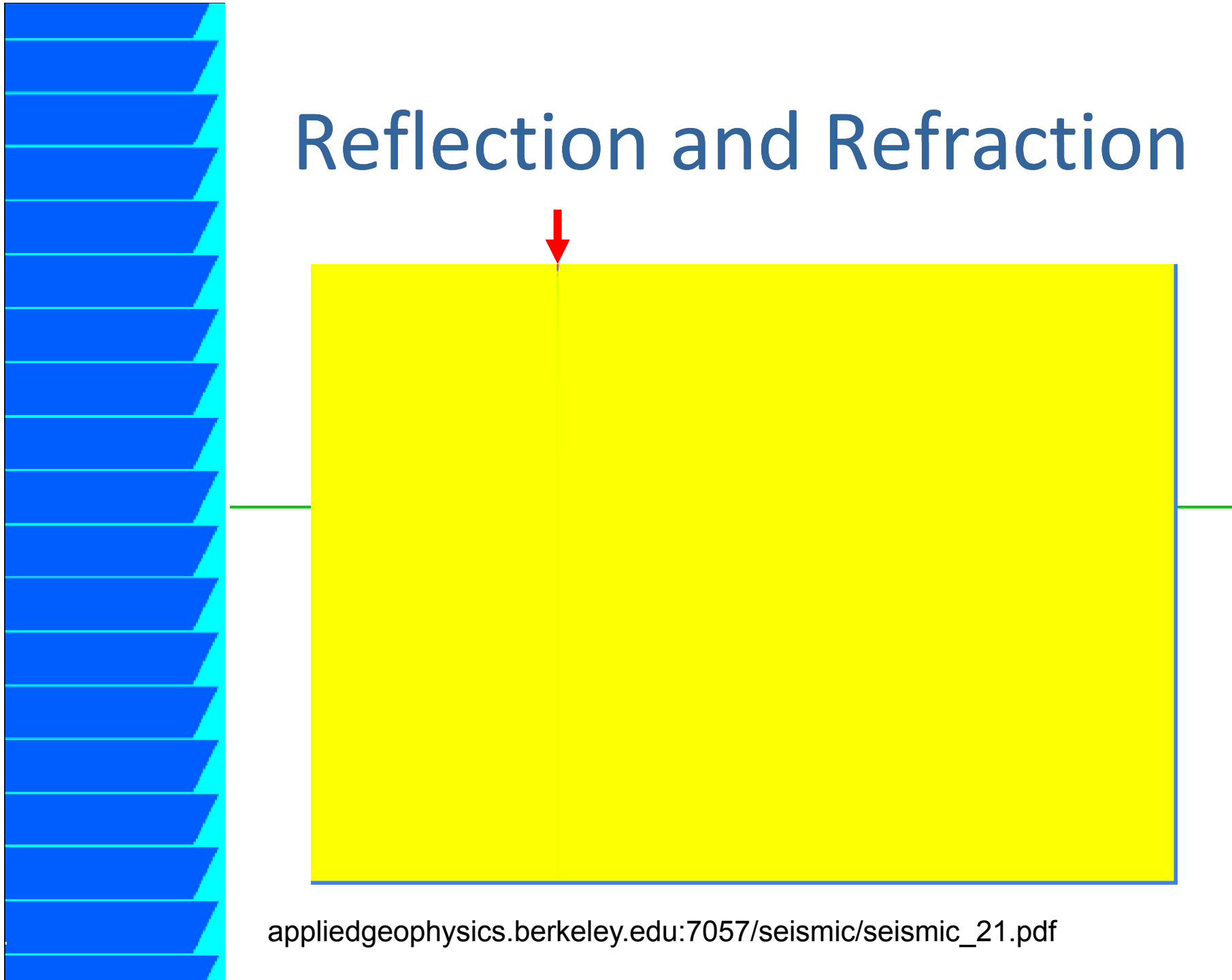



P-wave Reflection Coefficients (R)

Interface	R
Concrete-Air	-1.00
Concrete-Water	-0.71
Concrete-Steel	0.68

A negative value indicates that the stress changes sign when reflected: e.g., a compressive stress wave is reflected as a tensile stress wave.



Outline

- Basic principles
 - ◆ Wave types
 - ◆ Reflection
- Ultrasonic pulse velocity
- Sounding (chain drag)
- Impact-echo method
- Impulse-response method
- Ultrasonic-echo method

ASTM D4580 Practice for Measuring Delaminations

High Frequency
Ringing



Low Frequency
Rattle

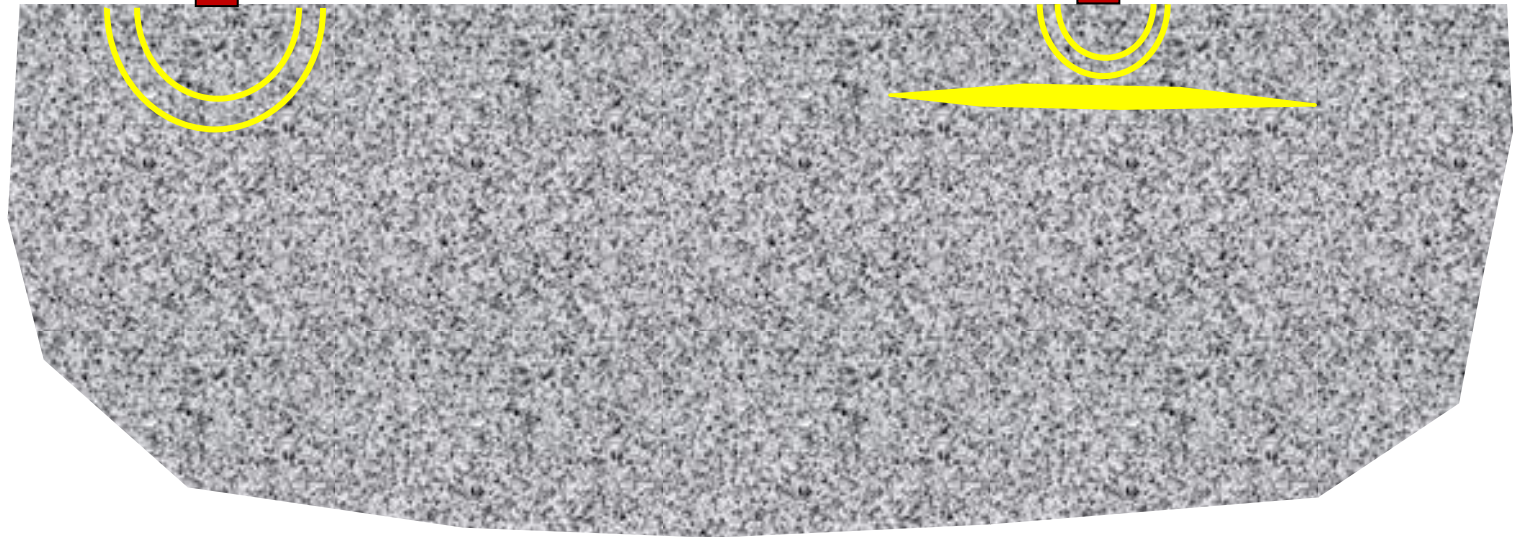
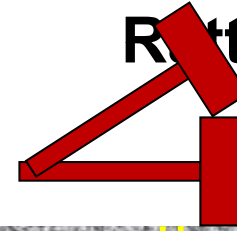

Sounding Methods

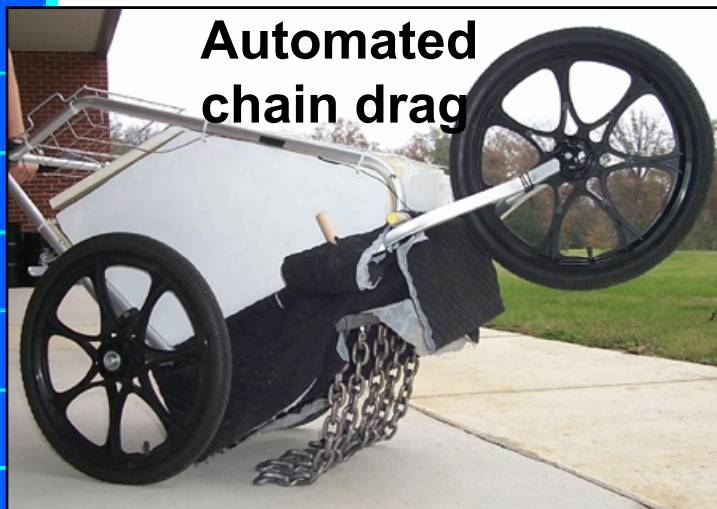

www.acoustics.org/press/146th/Costley.htm

www.soundingtech.com

Limitations

- Detection is difficult when:

Deep Defect

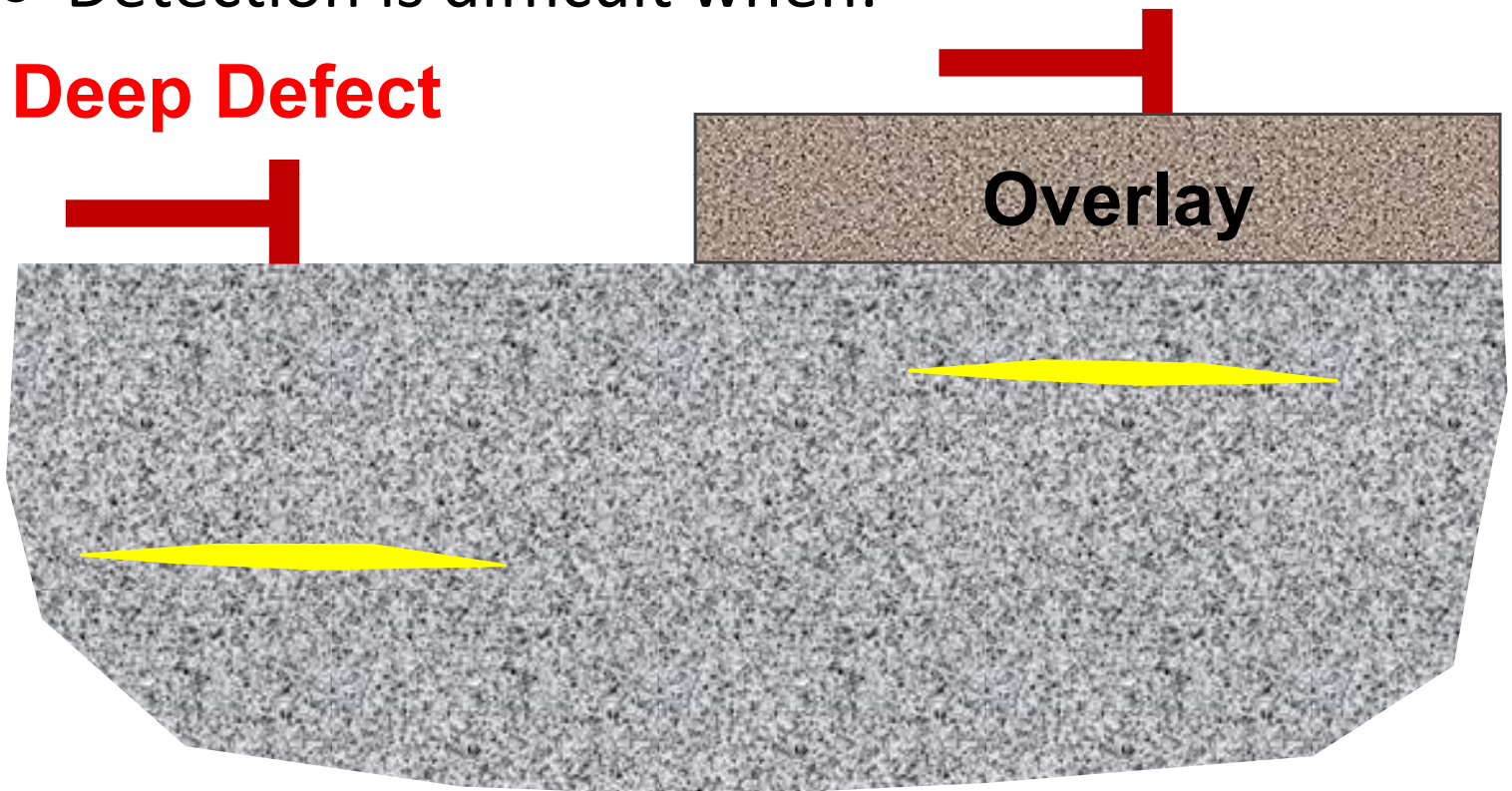

- Results are operator-dependent and may be affected by ambient noise



Impact Methods

- Impact-echo method
 - ◆ Depth of reflecting interface
- Impulse-response method
 - ◆ Comparative indication of mobility
- Spectral analysis of surface waves
 - ◆ Elastic constants of layered system

Impact-Echo Method

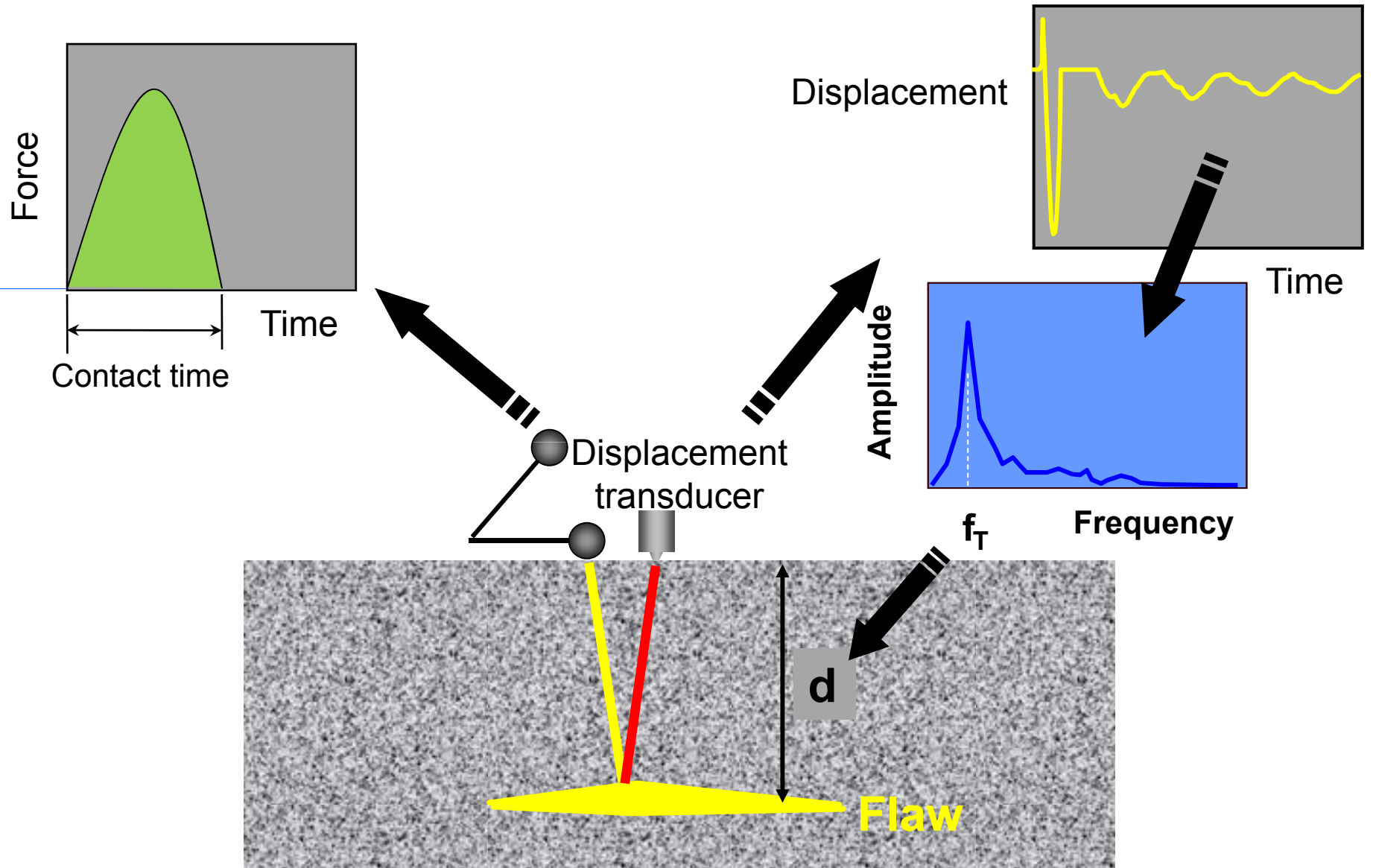

Field Testing System



Multiple Reflections of P-wave in a Plate

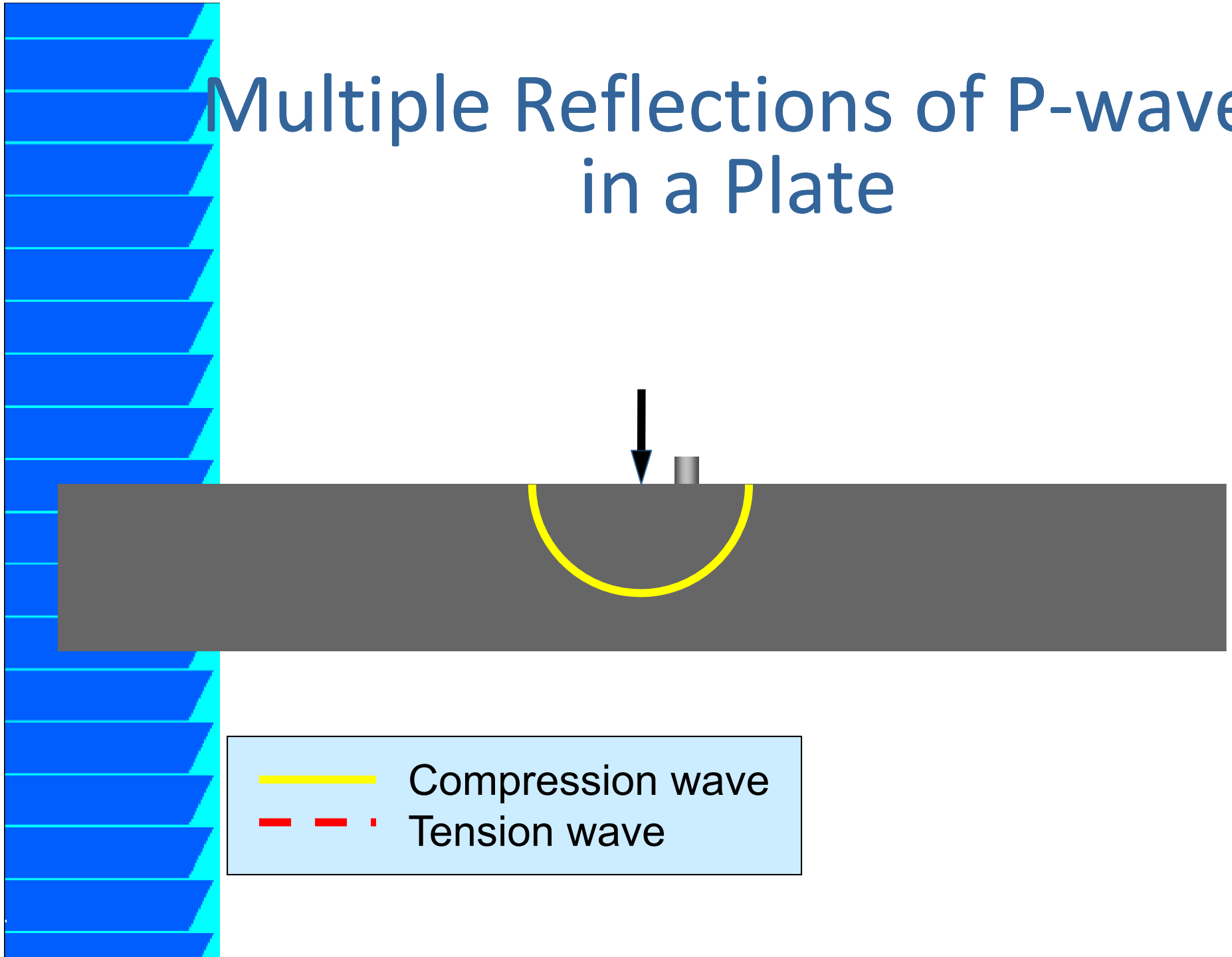

Multiple Reflections of P-wave in a Plate

Reflection from bottom

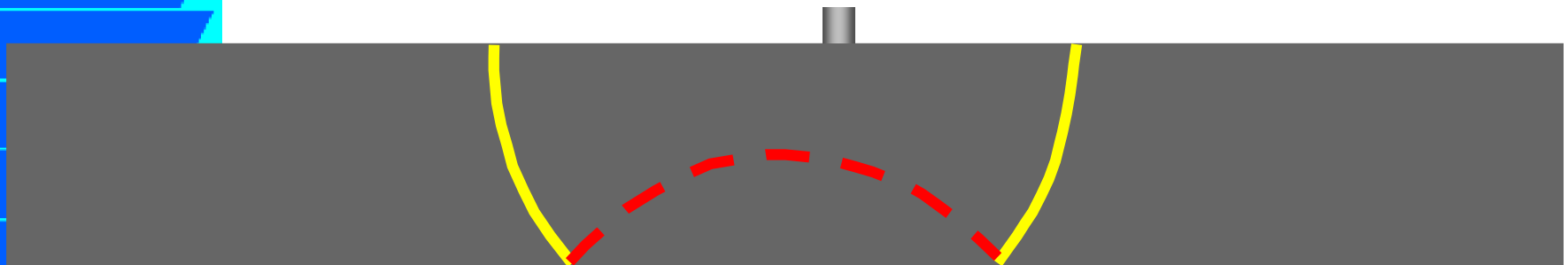

-  Compression wave
-  Tension wave

Multiple Reflections of P-wave in a Plate

First arrival

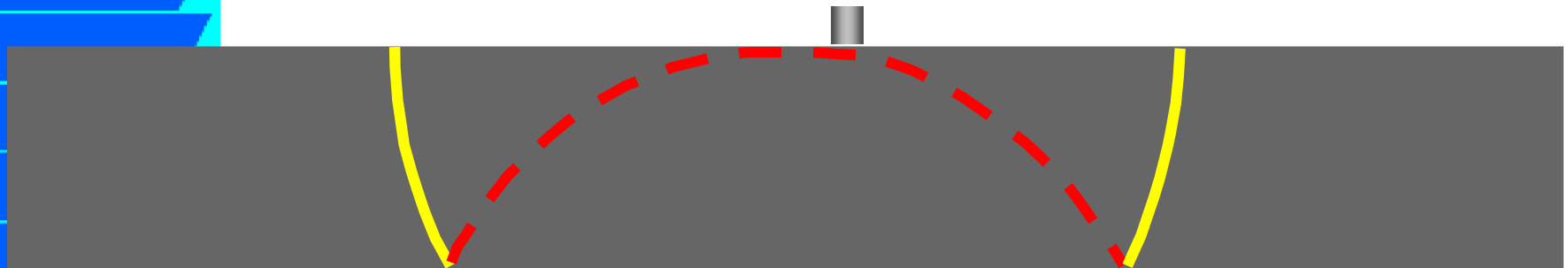

-  Compression wave
-  Tension wave

Multiple Reflections of P-wave in a Plate

Reflection from top and back to bottom

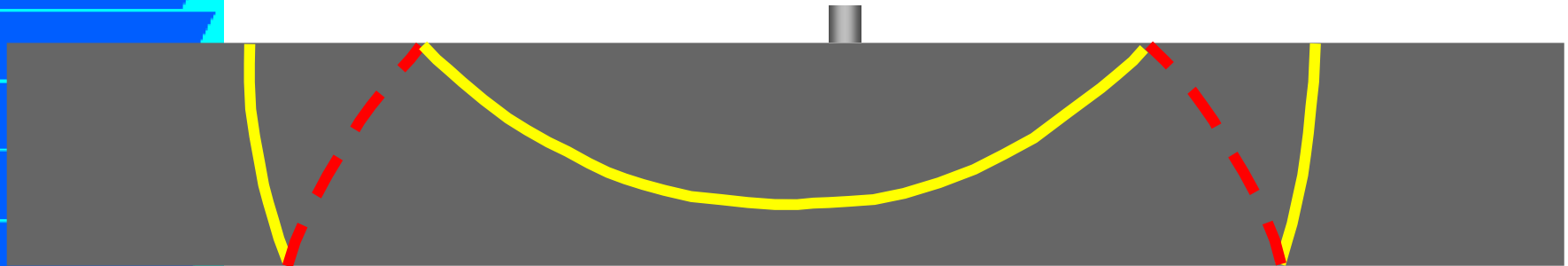

— Compression wave
- - - Tension wave

Multiple Reflections of P-wave in a Plate

2nd reflection from bottom

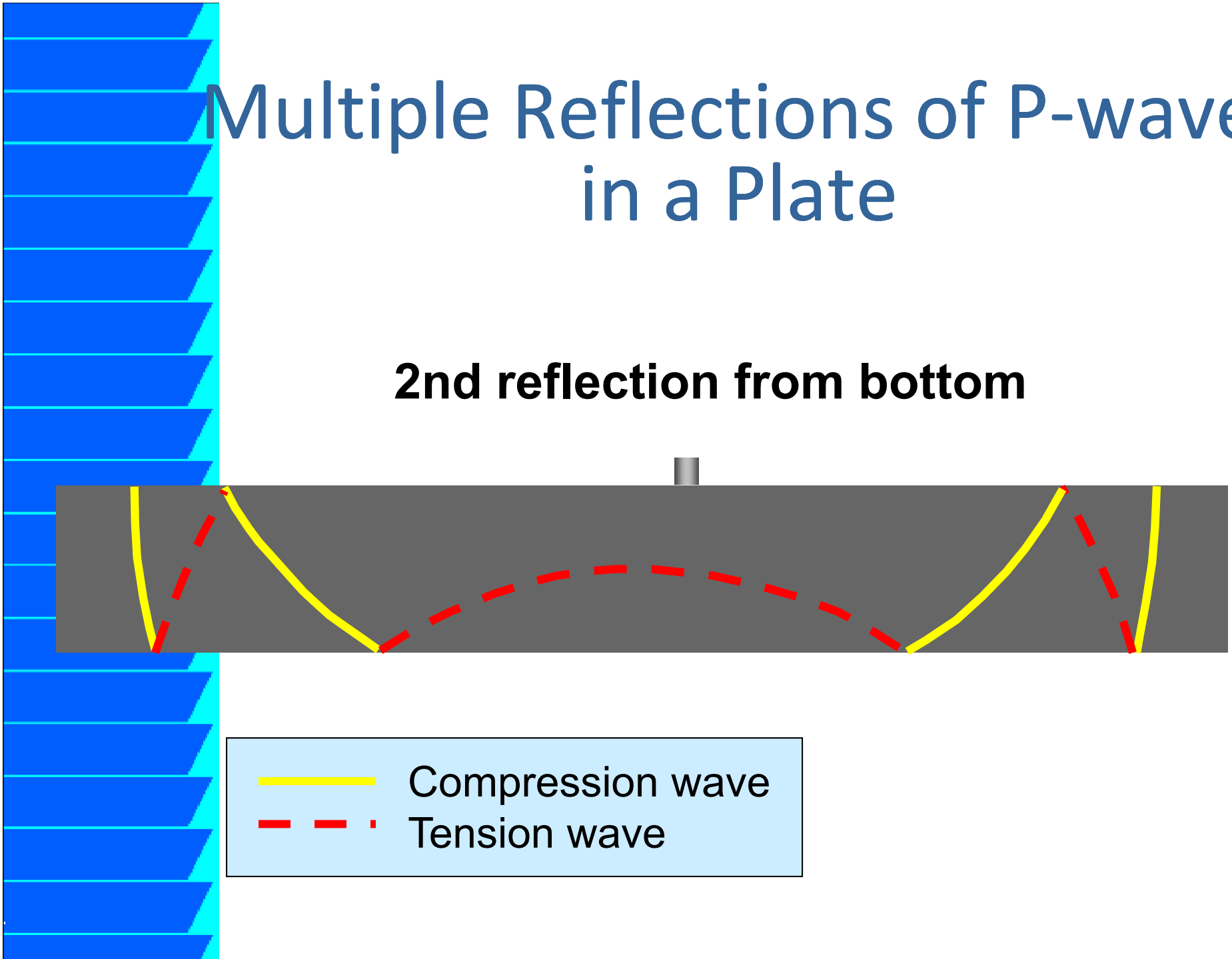

Multiple Reflections of P-wave in a Plate

Reflected wave arrives at top surface in a **periodic**
fashion

2nd arrival at top

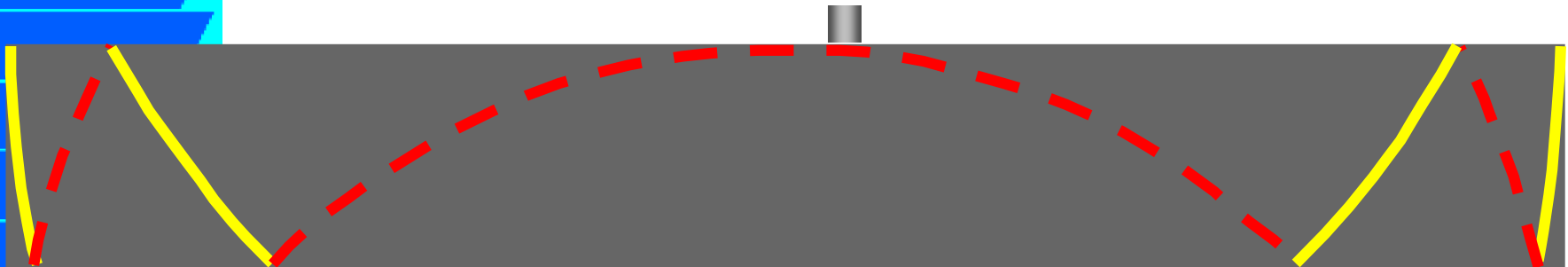

— Compression wave
- - - Tension wave

Surface Displacement Waveform

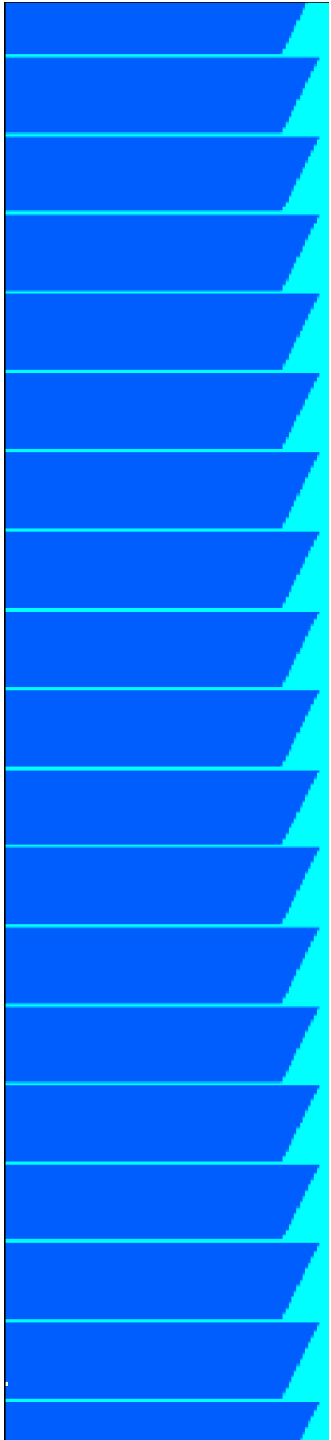
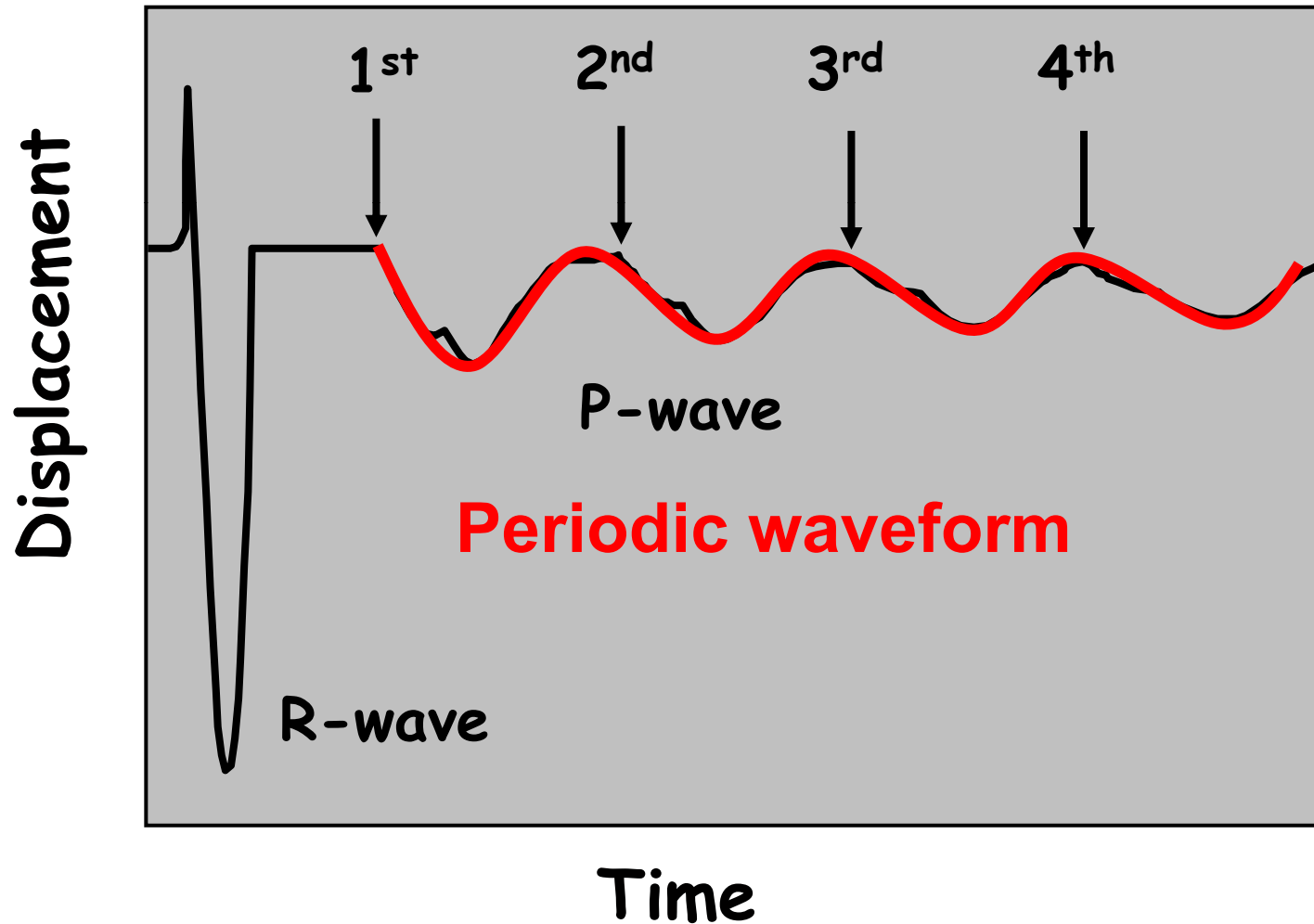

Frequency Analysis

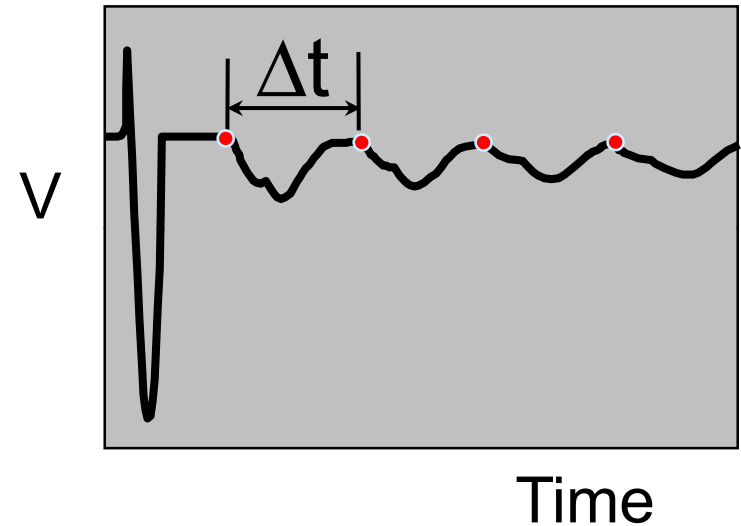
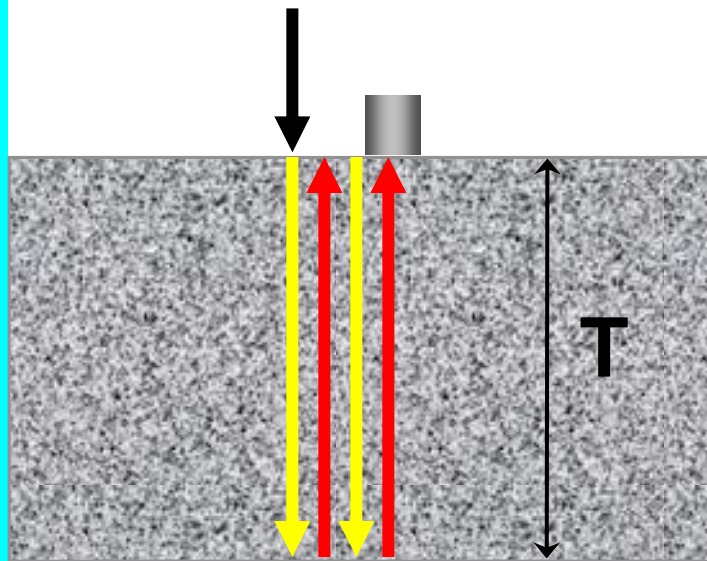

$$\Delta t = \frac{2T}{C_p} \quad f = \frac{1}{\Delta t} \quad \longrightarrow \quad T = \frac{C_p}{2f}$$

How do we determine f ?



Amplitude Spectrum

- By signal processing (FFT), waveform is converted into frequency domain to obtain amplitude spectrum
- Amplitude spectrum represents the amplitudes of the frequency components in the signal
- For a plate, the thickness frequency is the predominant peak in the spectrum

Examples

Solid Slab

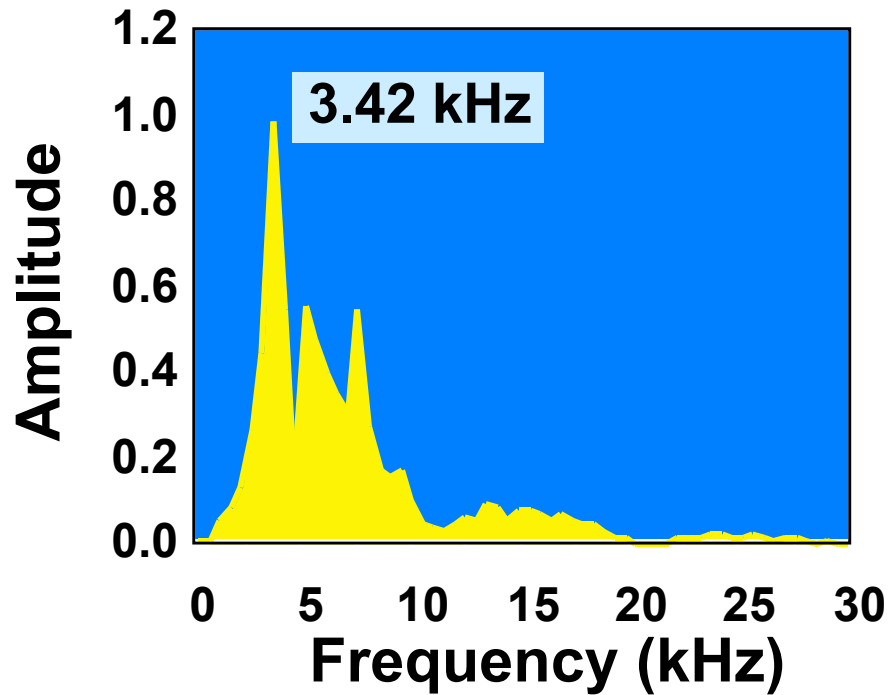
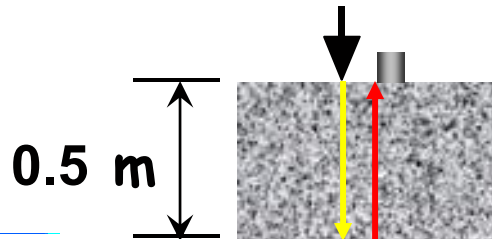

Void in Slab

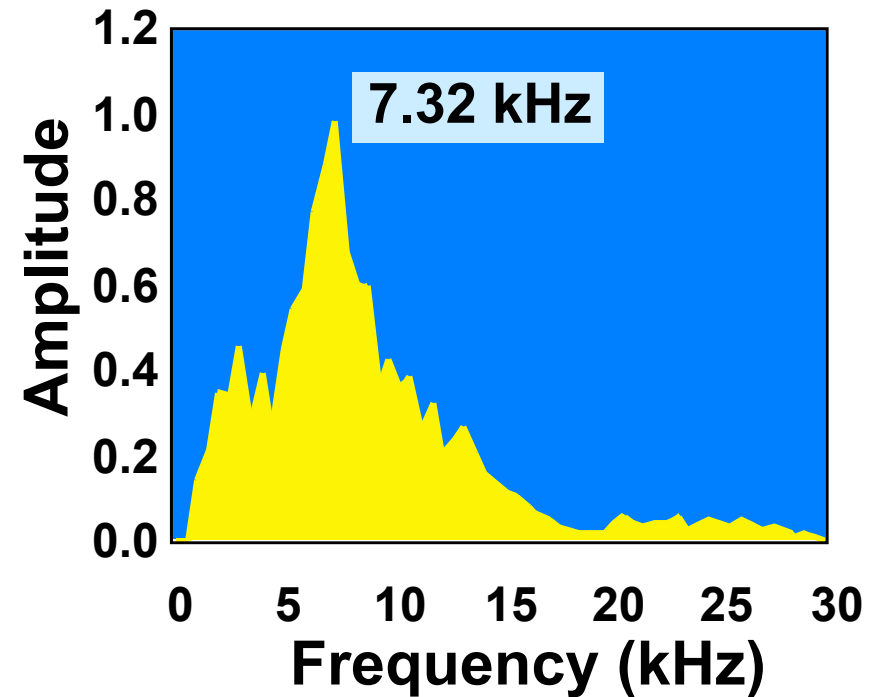
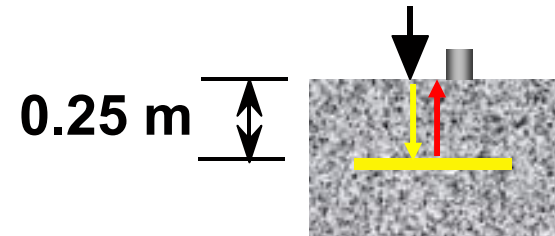



Applications

- Voids or honeycombing
- Delaminations (at reinforcement, asphalt/concrete interface, overlay, repair)
- Voids in grouted tendon ducts
- Bond “quality” –porosity at interface
- Thickness of plate-like structures (ASTM C1383)

ASTM C1383



Designation: C 1383 – 04

Standard Test Method for Measuring the P-Wave Speed of Concrete Plates Using the Impact-Echo Method

This standard is issued under the fixed designation C 1383; the number immediately following the designation indicates the year of original adoption or, in the case of revision, the year of last revision. A number in parentheses indicates the year of last reapproval. A superscript epsilon (ϵ) indicates an editorial change since the last revision or reapproval.

1. Scope*

1.1 This test method covers procedures for determining the thickness of concrete slabs, pavements, bridge decks, walls, or other plate-like structure using the impact-echo method.

1.2 The following two procedures are covered in this test method:

1.2.1 *Procedure A: P-Wave Speed Measurement*—This procedure measures the time it takes for the P-wave generated by a short-duration, point impact to travel between two transducers positioned a known distance apart along the surface of a structure. The P-wave speed is calculated by dividing the distance between the two transducers by the travel time.

1.2.2 *Procedure B: Impact-Echo Test*—This procedure measures the frequency at which the P-wave generated by a

**Procedure A:
Determine wave speed**

**Procedure B:
Thickness frequency**

3. Terminology

3.1 Definitions:

3.1.1 *acoustic impedance*—the product of P-wave speed and density that is used in computations of characteristics of stress wave reflection at boundaries.

3.1.2 *amplitude spectrum*—a plot of relative amplitude versus frequency that is obtained from the waveform using a Fourier transform technique.

3.1.3 *Fourier transform*—a numerical technique used to

Concrete
E 1316 Terminology for Nondestructive Examinations



Procedure A: Determine C_p

- Perform impact-echo test and measure thickness at corresponding point
- Surface measurement of P-wave: C_p^s
 - ◆ Travel time between two transducers

Hole Drilling Method

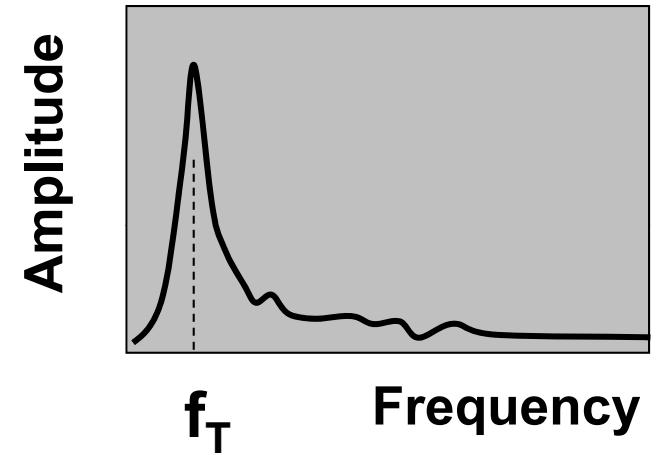
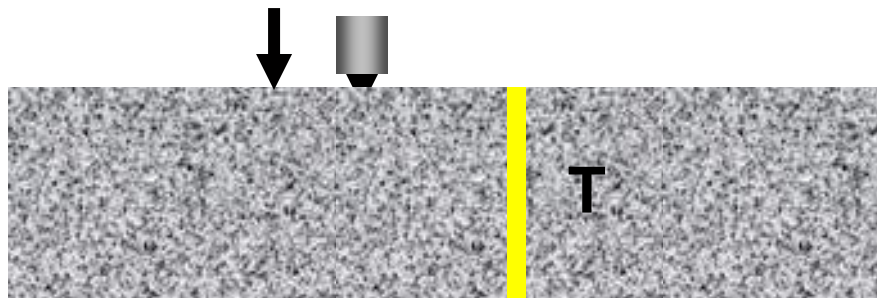

$$C_p = 2f_T T$$

Surface Measurement of P-Wave Speed

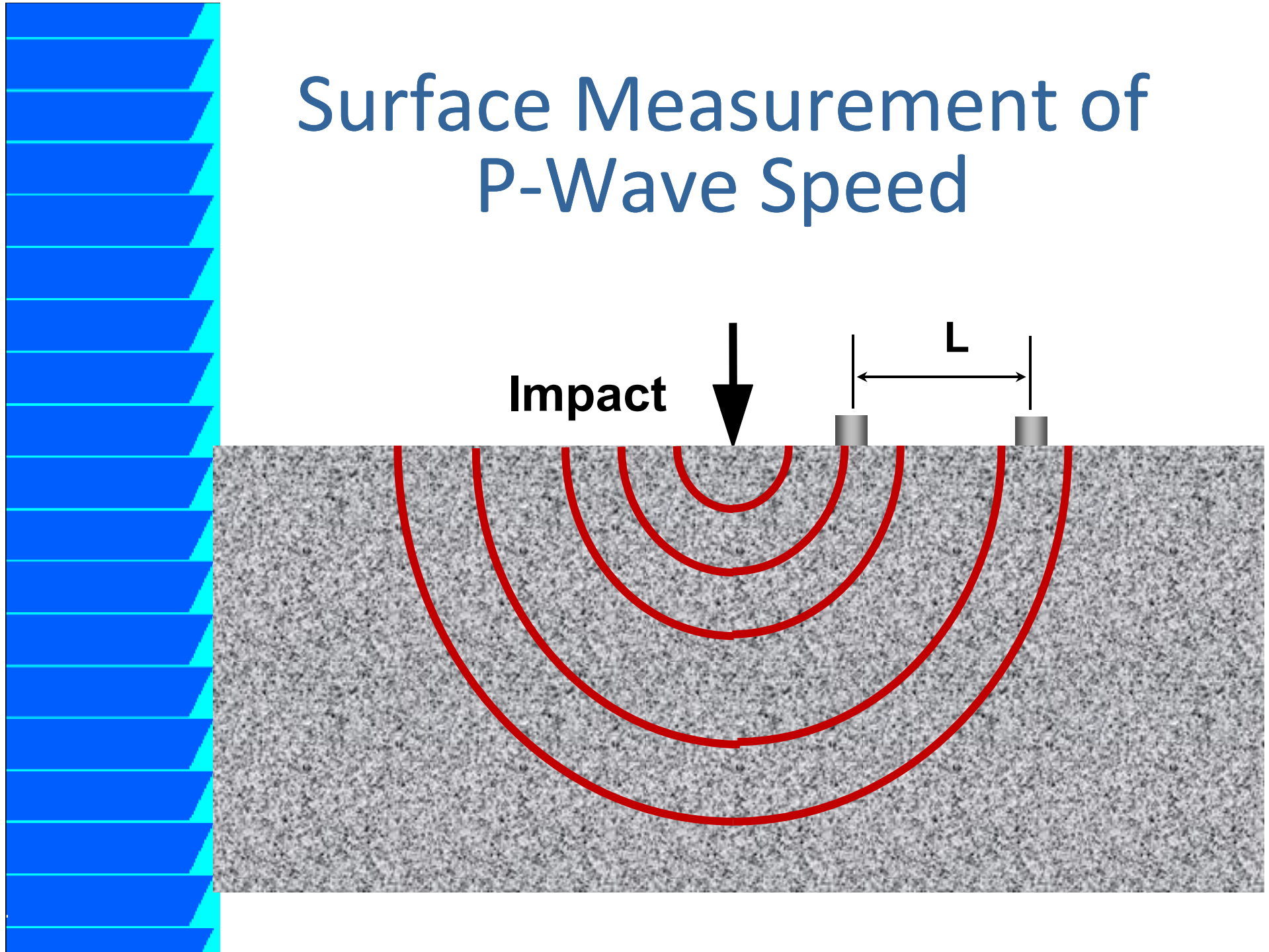

Surface Measurement of P-Wave Speed

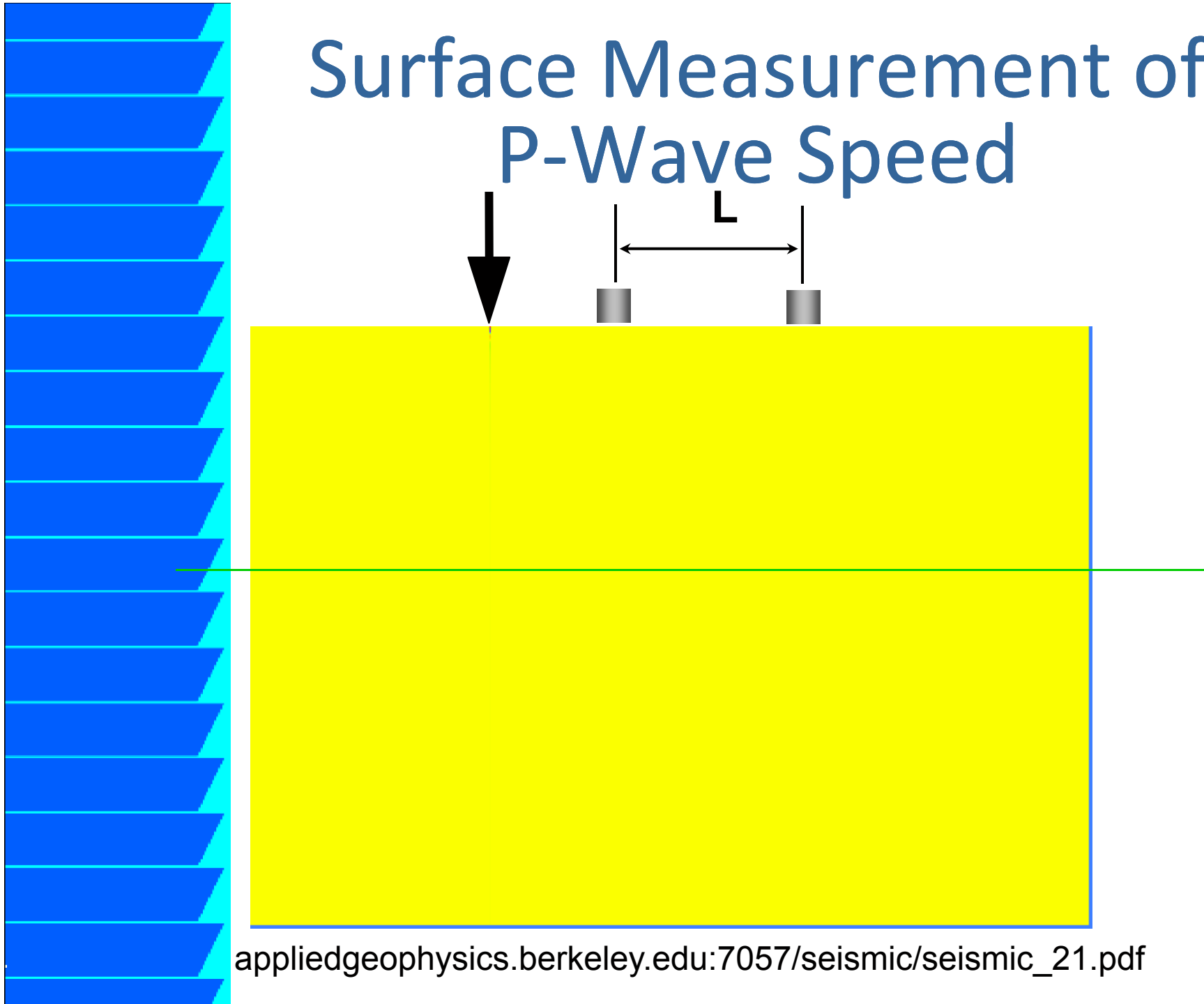

Surface Measurement

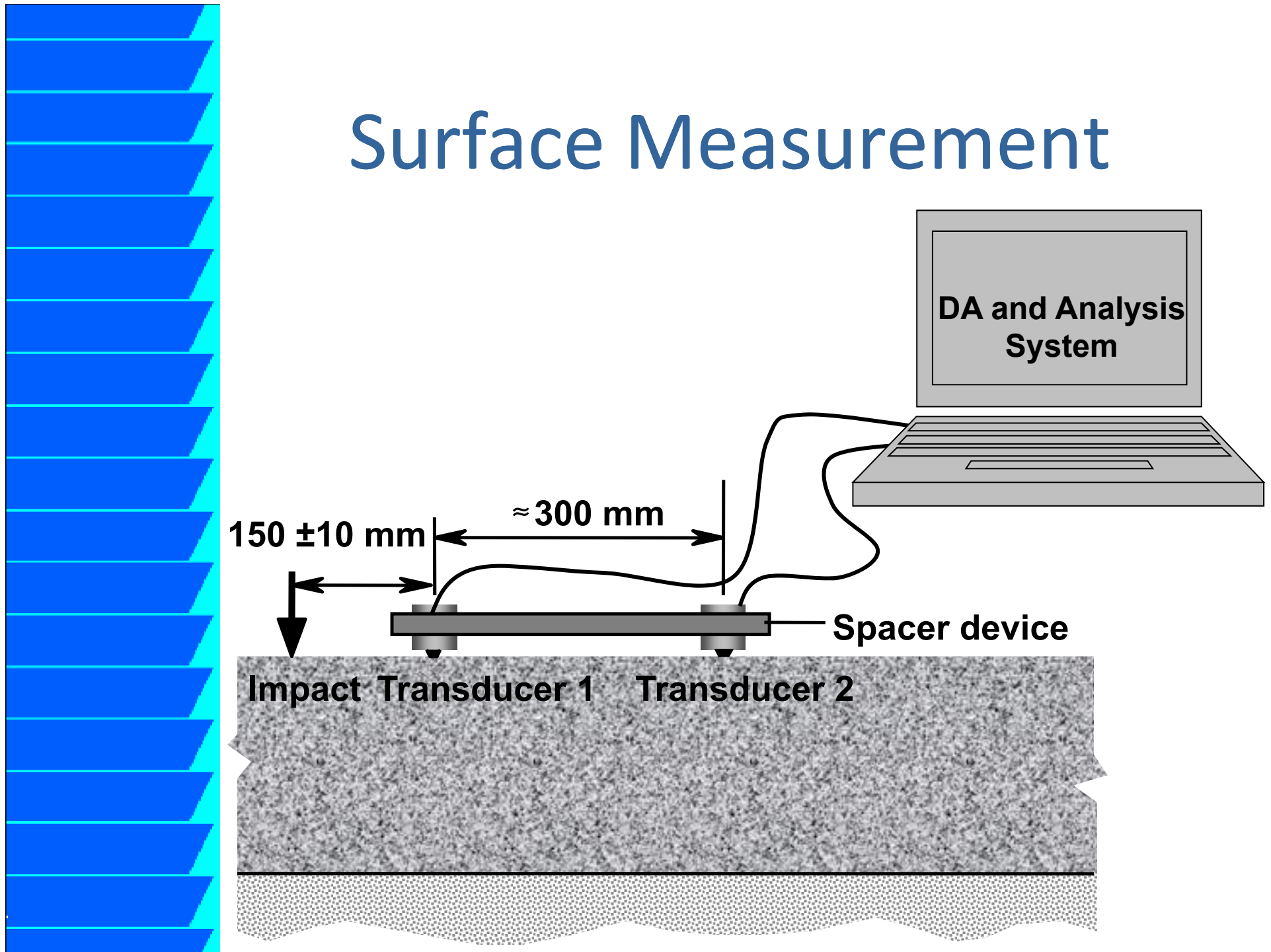



Impactor

Procedure B: Thickness Frequency

$$T = \frac{0.96 C_p^s}{2 f_T}$$

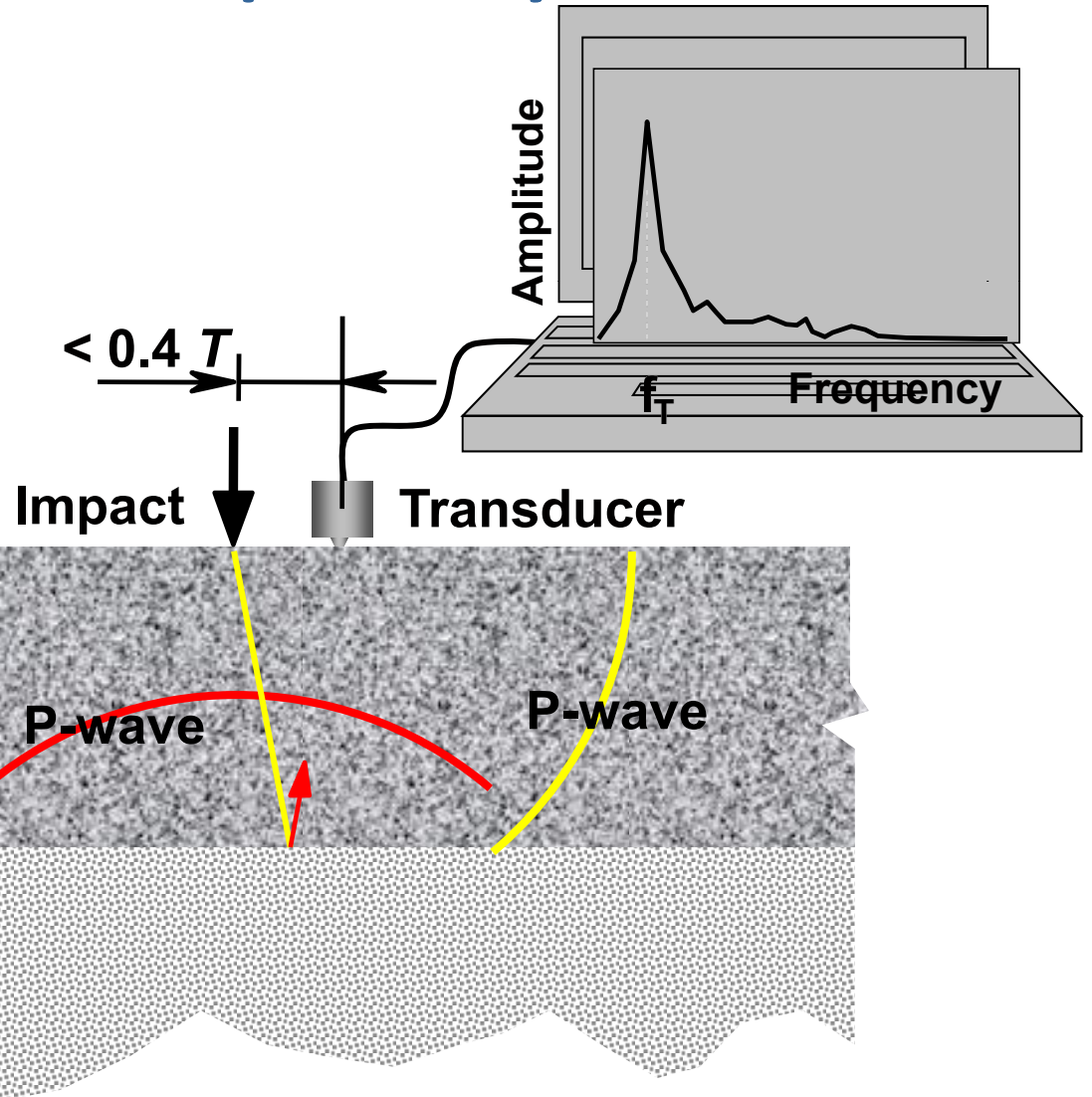



Impact-Echo Limitations

- Complexity
- Point-to-point testing
- Takes time to evaluate test surface
- Closely spaced testing required for “visualization” methods

New multi-sensor system based on ultrasonic-echo technique overcomes some of these limitations



Impulse-Response Method

- Originated as method to test deep foundations
- Requires measurement of impact force
- Signal processing examines the impact response per unit of applied force as a function of frequency
- Lower frequency than impact-echo

Impulse-Response for Shafts

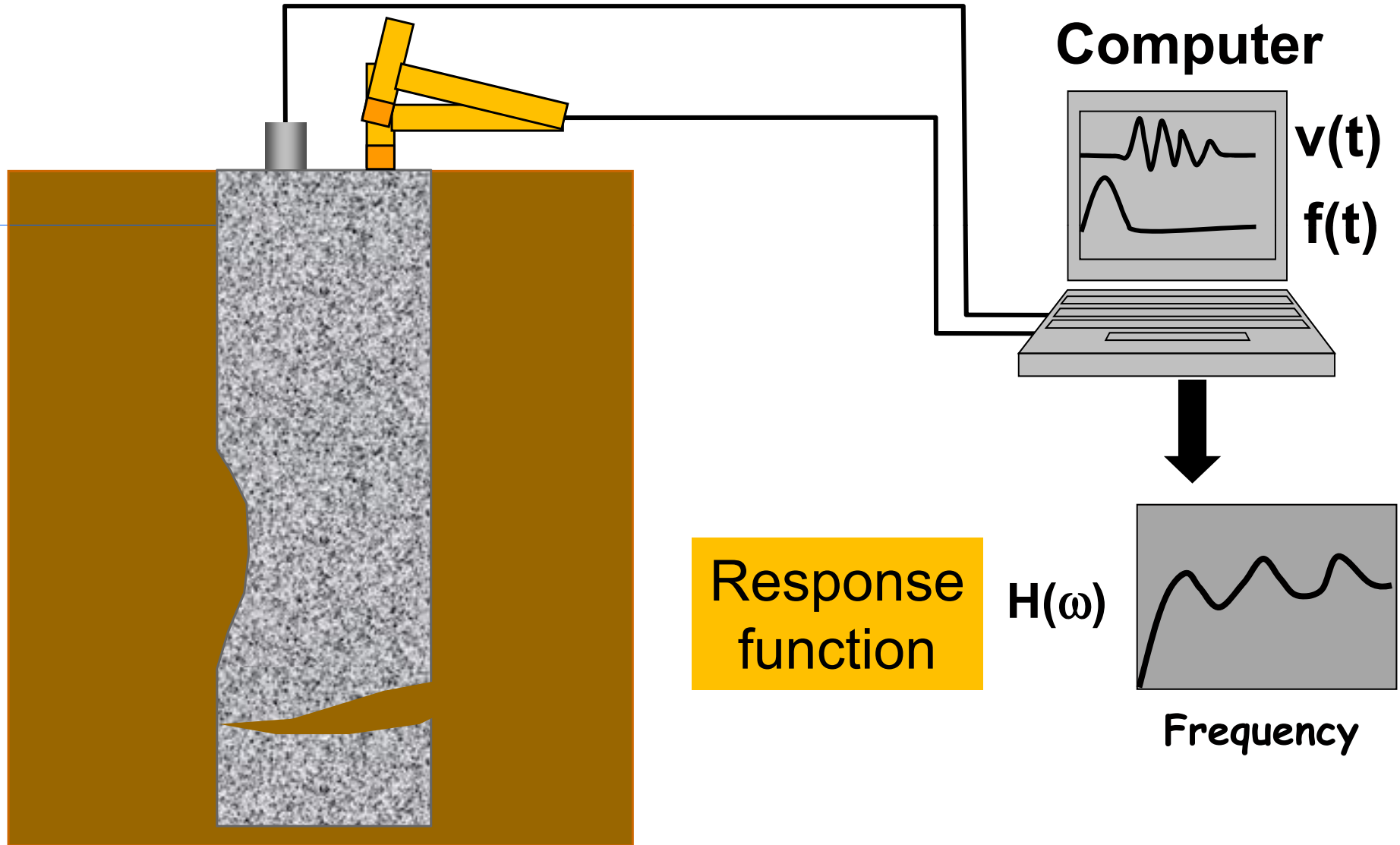

Impulse-Response Test System

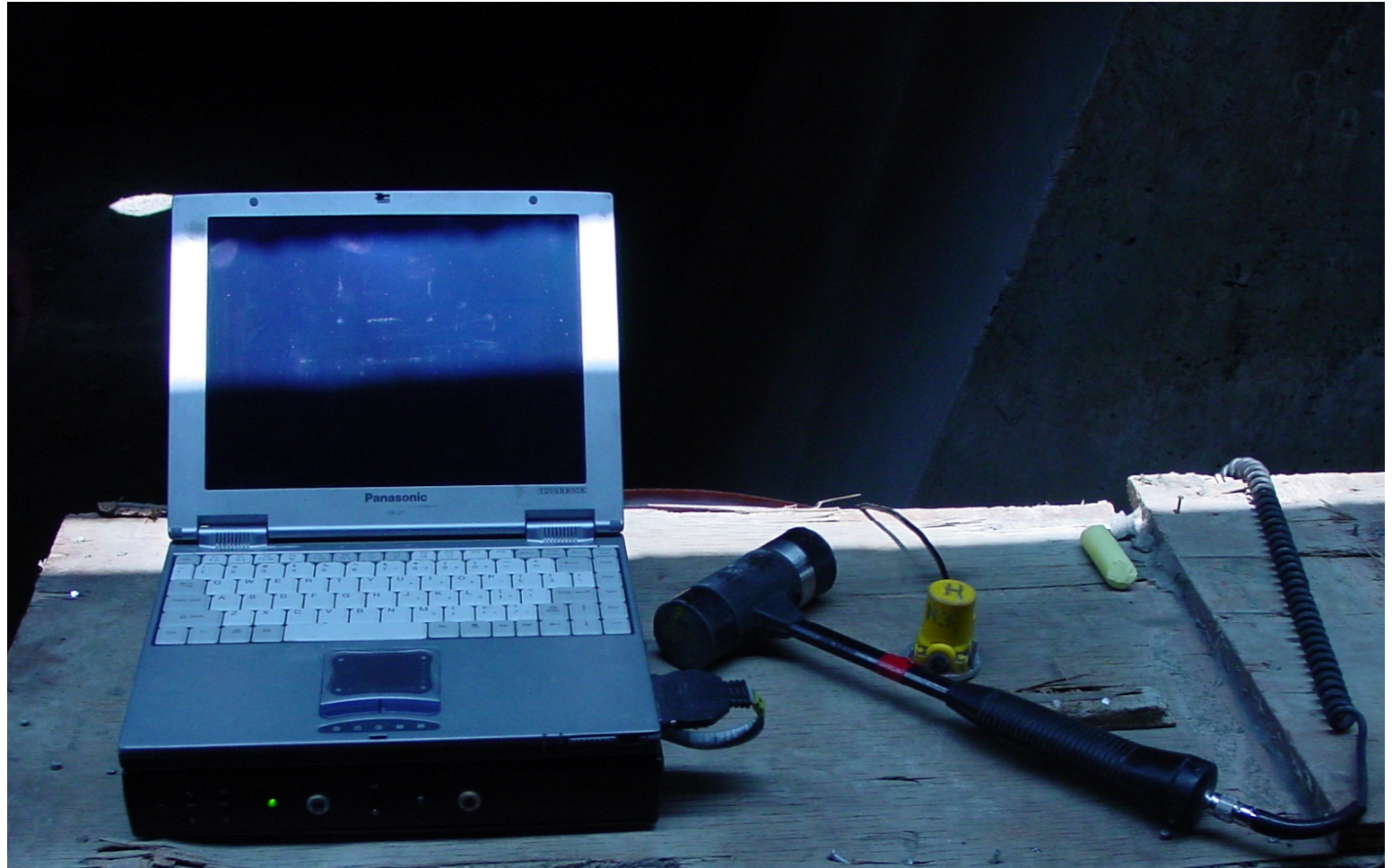



Transfer Functions

Measured Response	Transfer Function	Units
Displacement	Dynamic Compliance	L/F
Velocity	Mobility	(L/s)/F
Acceleration	Accelerance	(L/s ²)/F

Idealized Mobility Plot of Pile

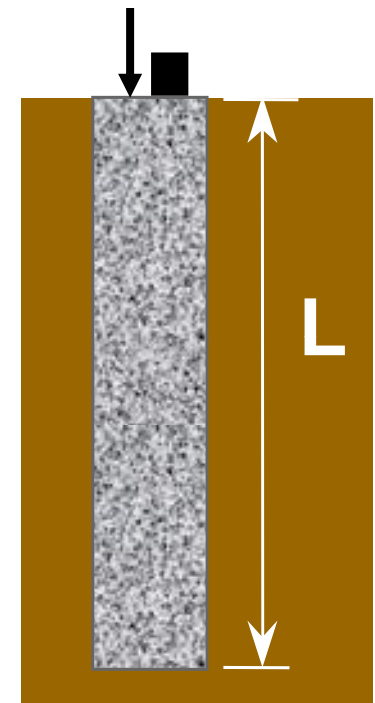
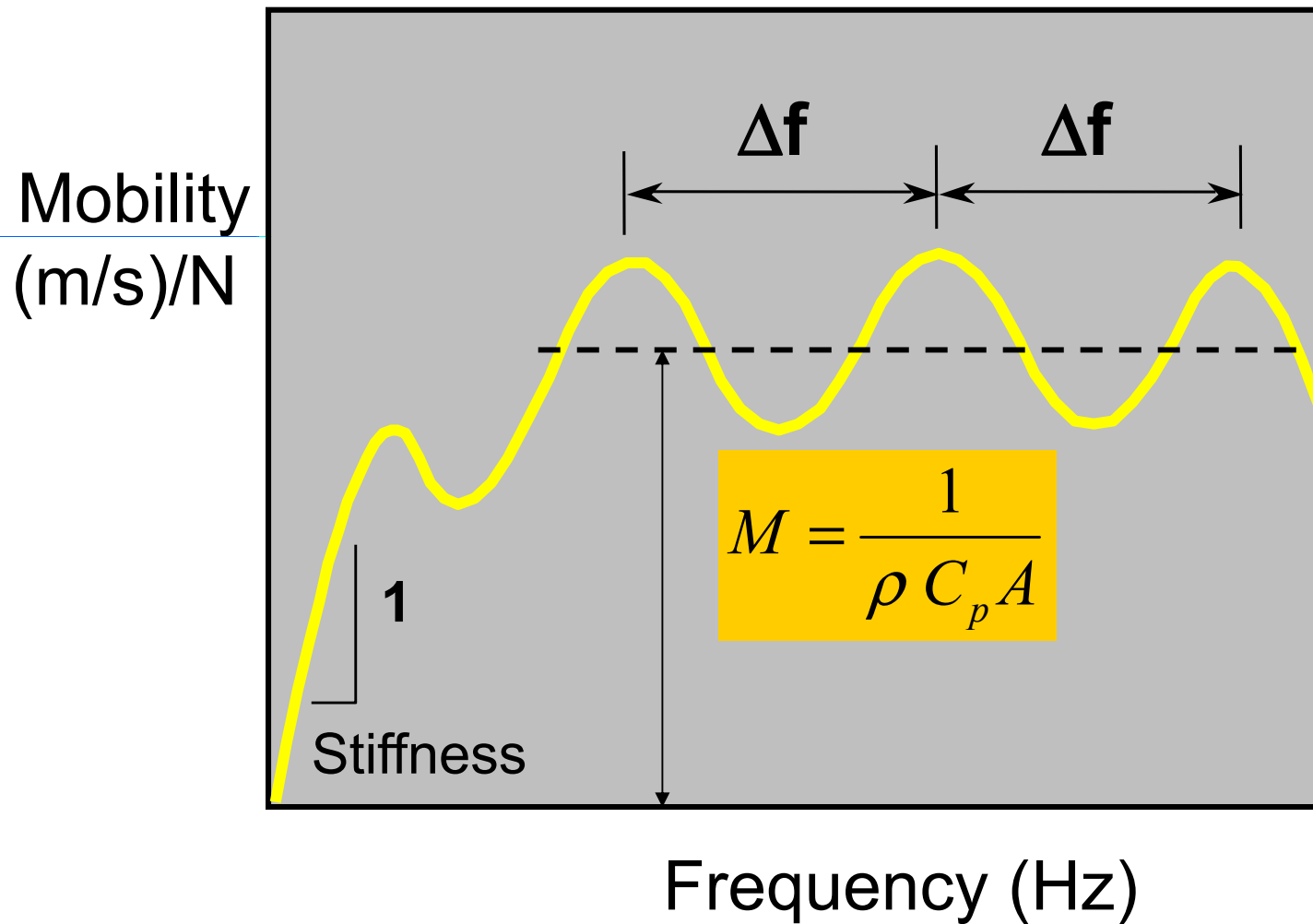

$$L = \frac{C_p}{2 \Delta f}$$



Application to Plates

- Impulse-response testing has its origin in the testing of drilled shafts and piles
- Recent work has demonstrated that it can also be used successfully to assess plate-like structures
- Comparative test to assess differences in response to impact force
 - ◆ Locate anomalous regions

Hammer and Geophone Position

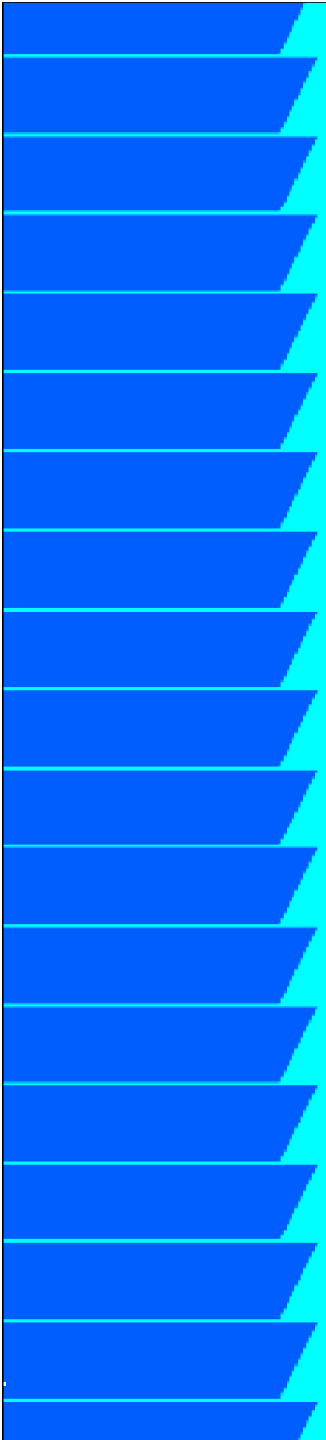
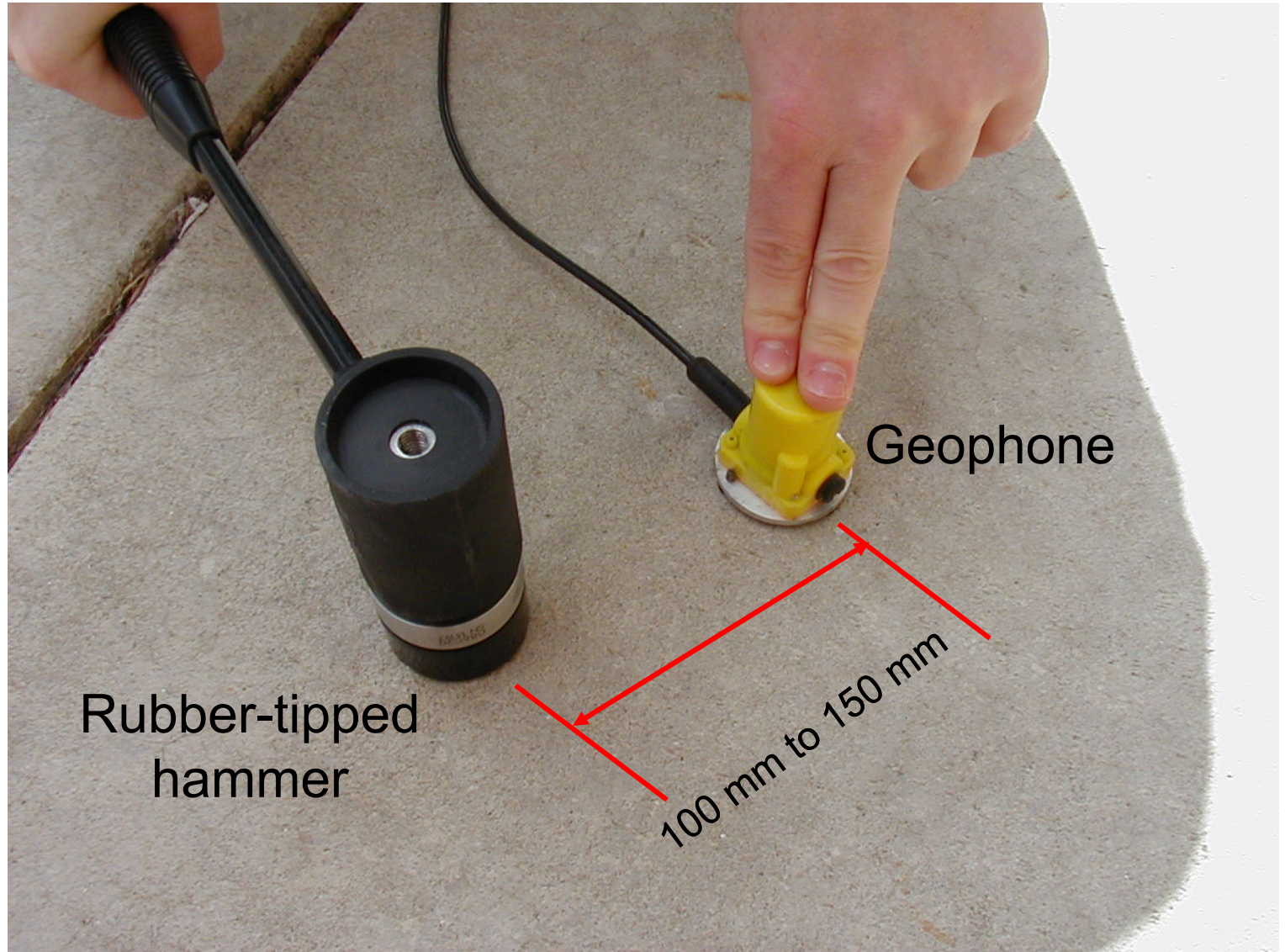



Impulse-Response Testing of Plate-like Structures

- Permits rapid screening of suspect structures
- Various features of mobility plot are used as indicators of conditions
 - ◆ Dynamic stiffness (initial slope 0 to 50 Hz)
 - ◆ Average mobility (100 to 800 Hz)
 - ◆ Slope of mobility vs. frequency
 - ◆ Ratio of low frequency peak mobility to mean mobility
- ASTM Standard under development

Example of I-R Test of Slab

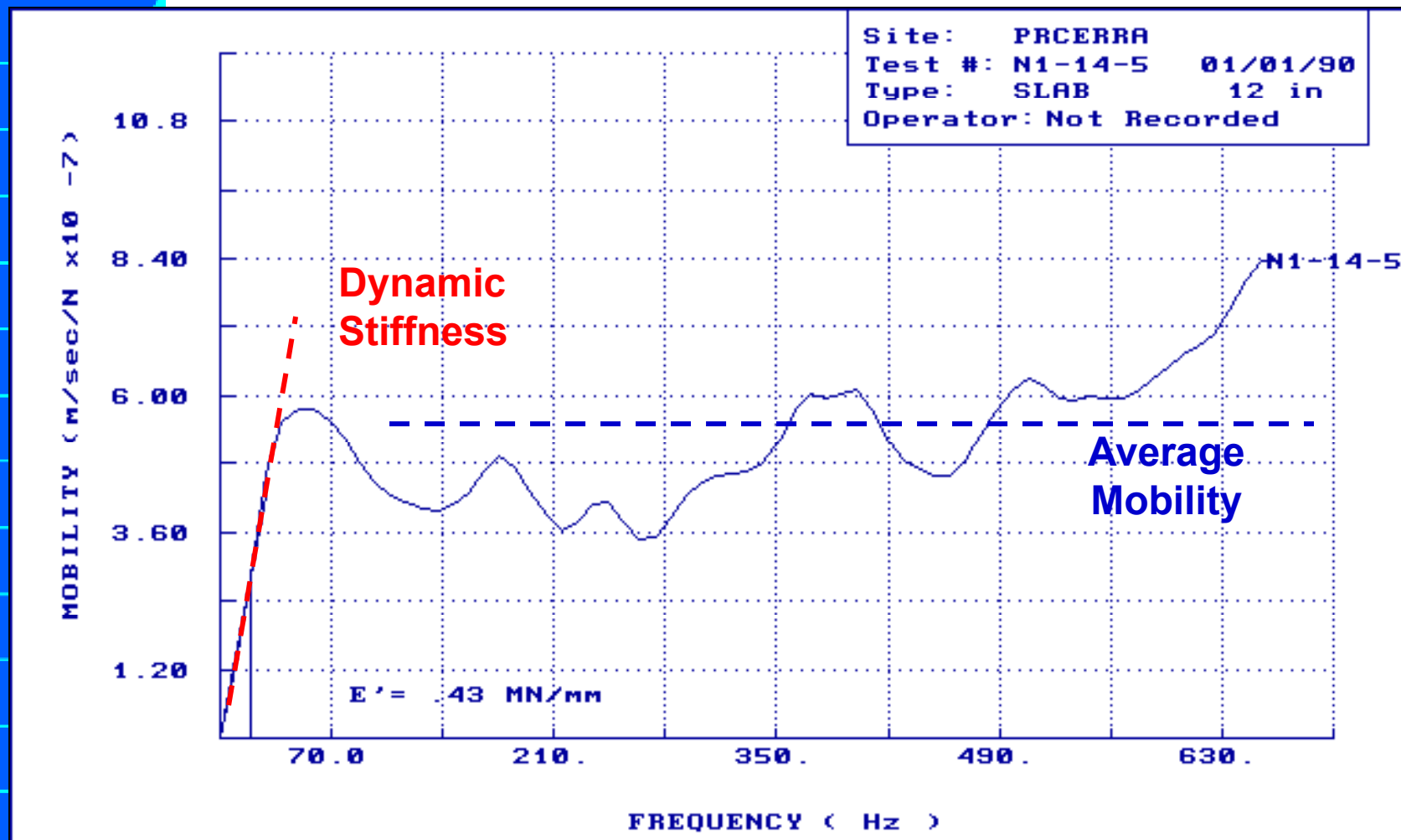



Average Mobility of Slab

- I-R test causes flexural vibration of slab within vicinity of impact
- Average mobility is affected by
 - ◆ Quality of the concrete (C_p)
 - ◆ Presence of internal voids
 - ◆ Plate thickness
 - ◆ Support conditions

Void Below Slab

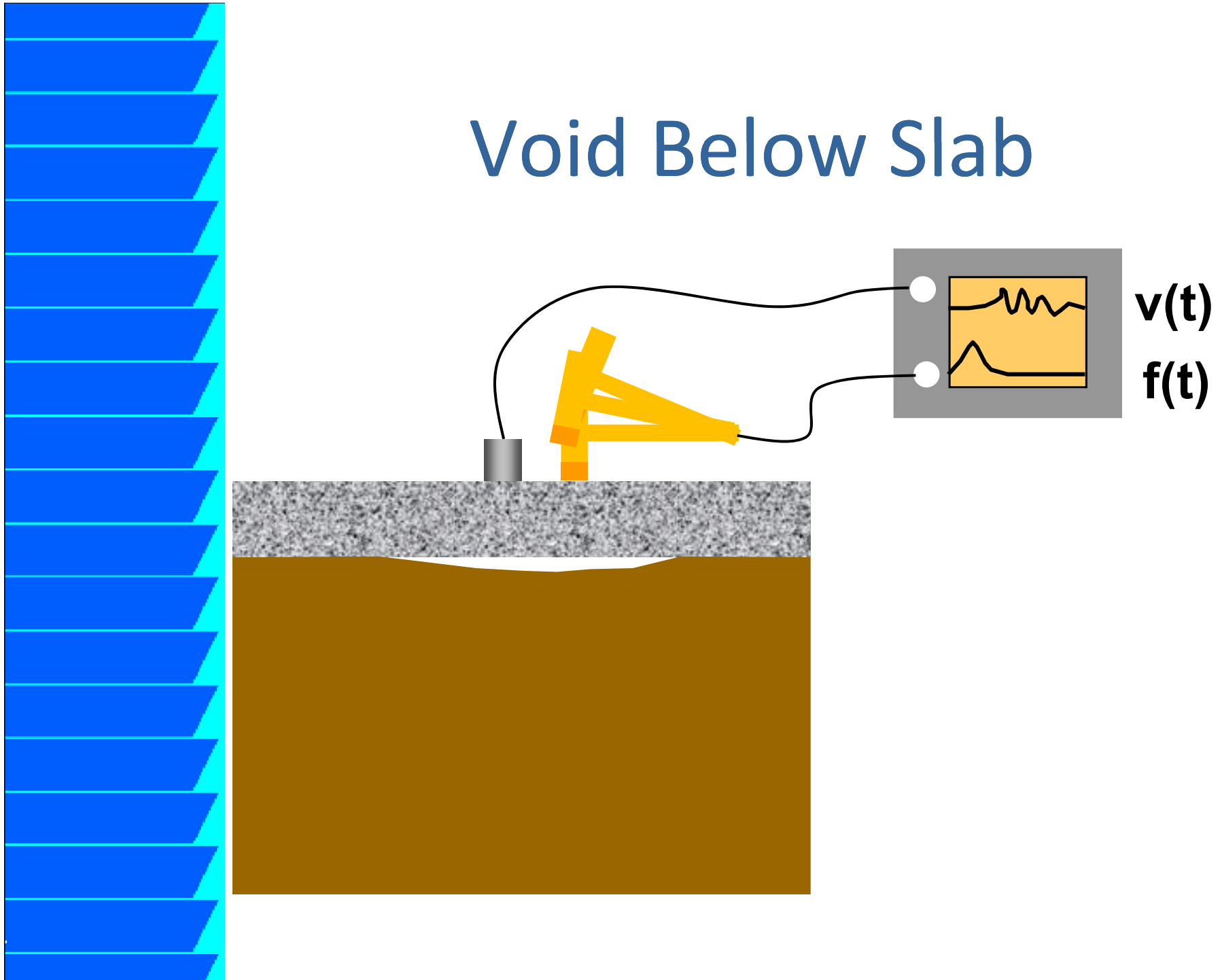

Void Below Slab

Low frequency flexural vibration

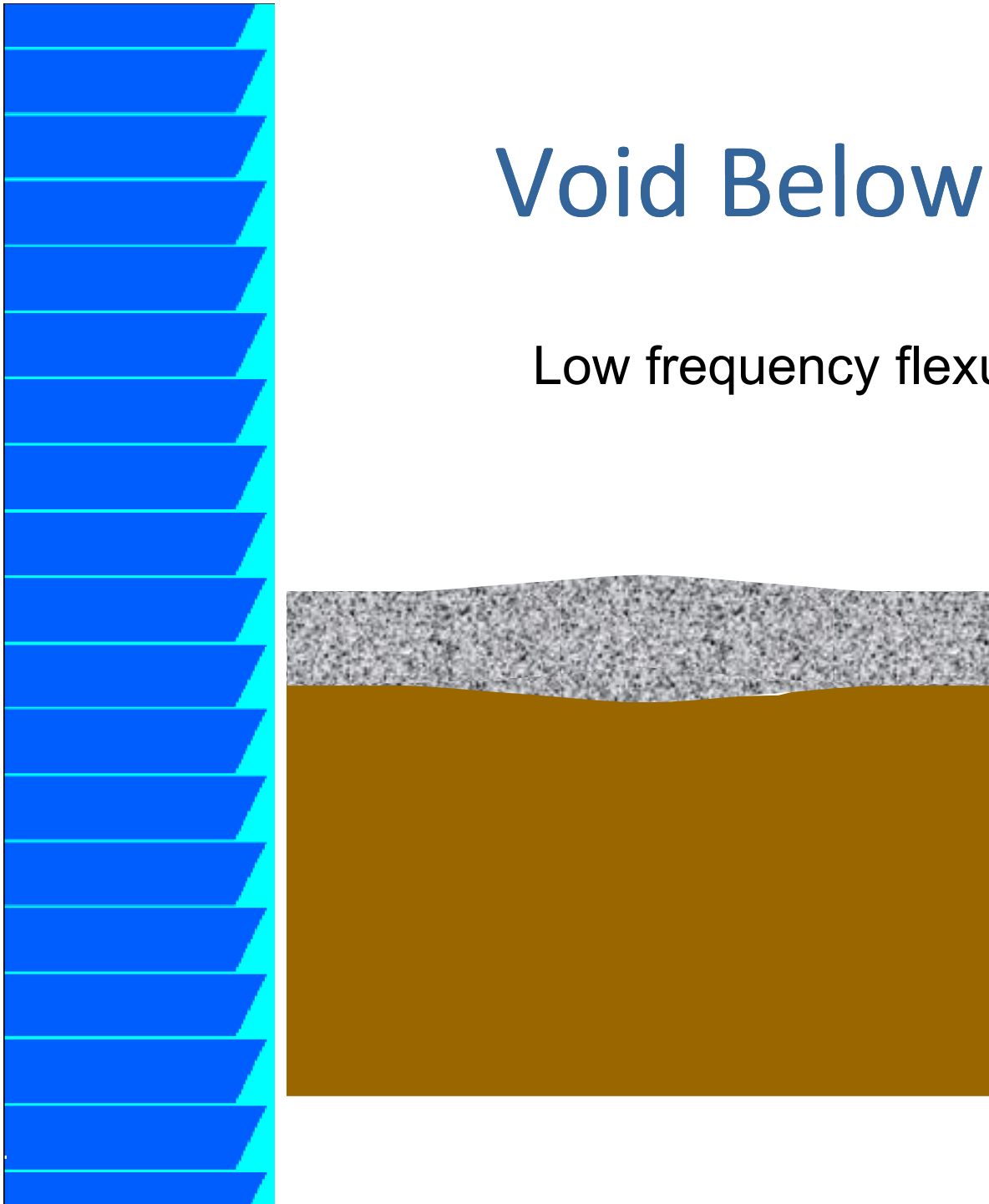

Void Below Slab: High Peak at Low Frequency

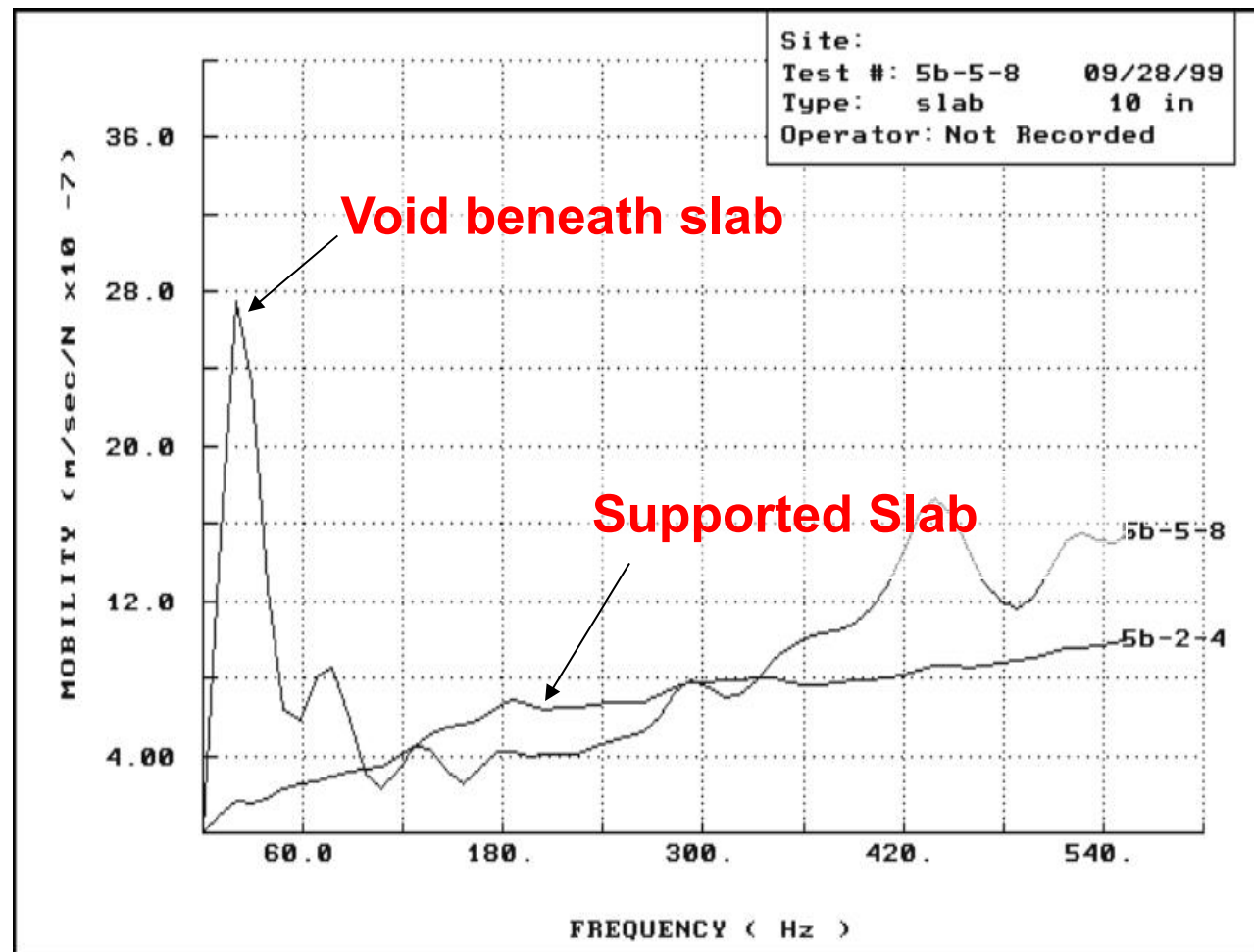



Mobility Slope

- Slope of best-fit line to mobility spectrum between 100 and 800 Hz
- A high mobility slope has been found to be indicative of poorly consolidated concrete

Mobility Slope

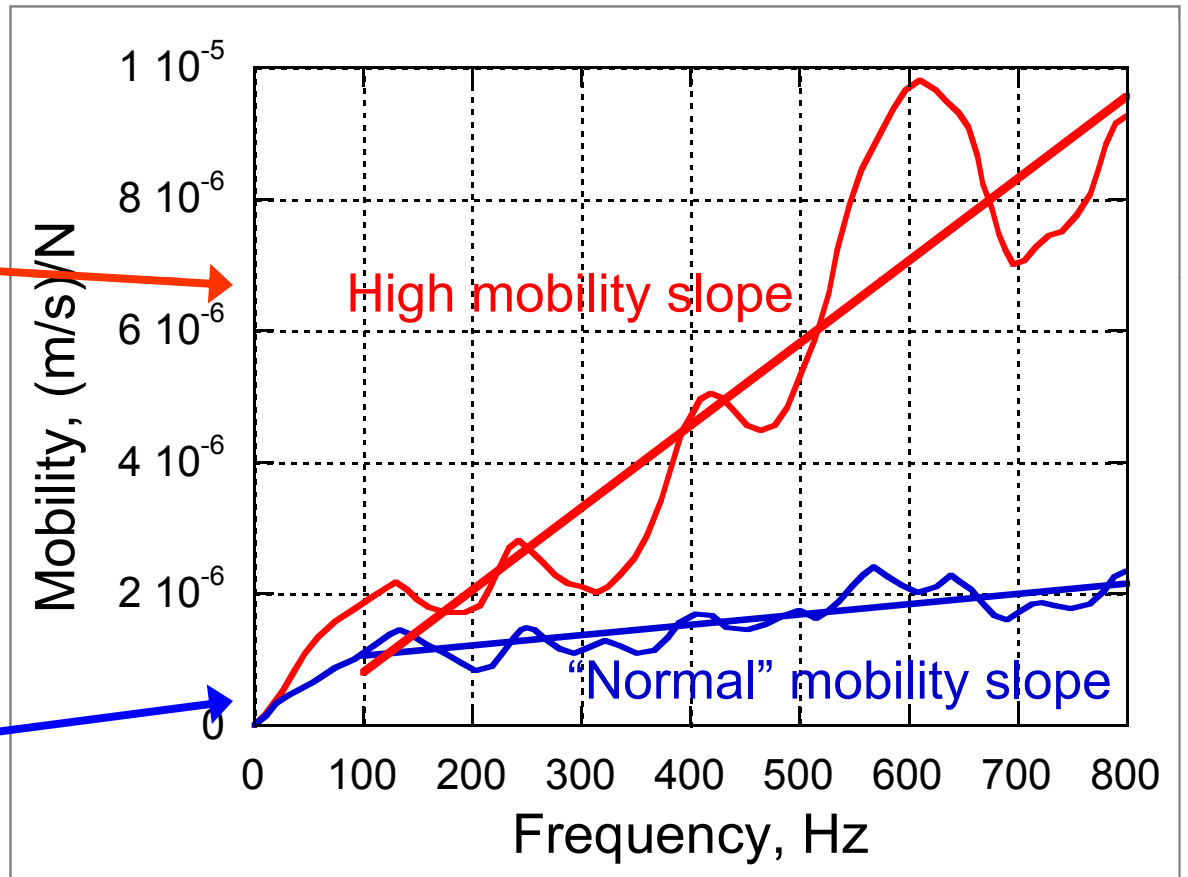
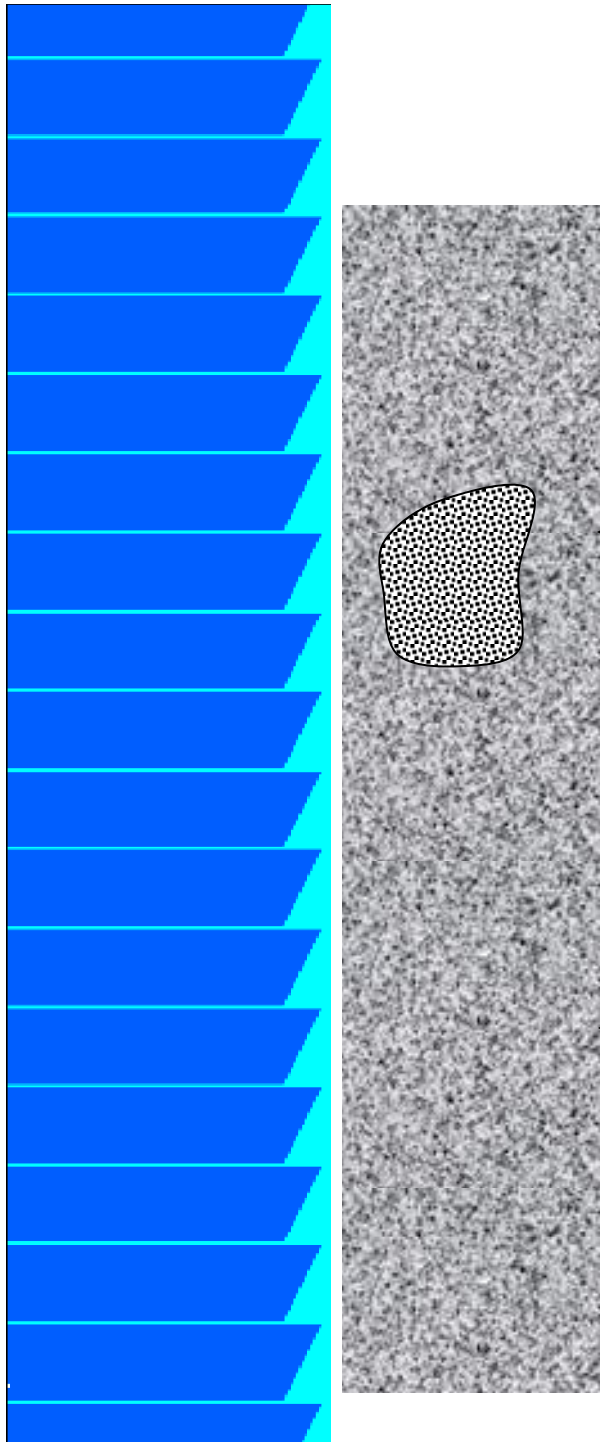



Applications

- Detecting voids beneath slabs-on-ground
- Detecting delaminations and honeycombing
- Detecting slab curling
- Evaluation of anchorage of exterior wall panels
- Location of areas of distributed cracking (F-T, ASR)
- Evaluation of load transfer at construction joints

Example

Contour plot of average mobility

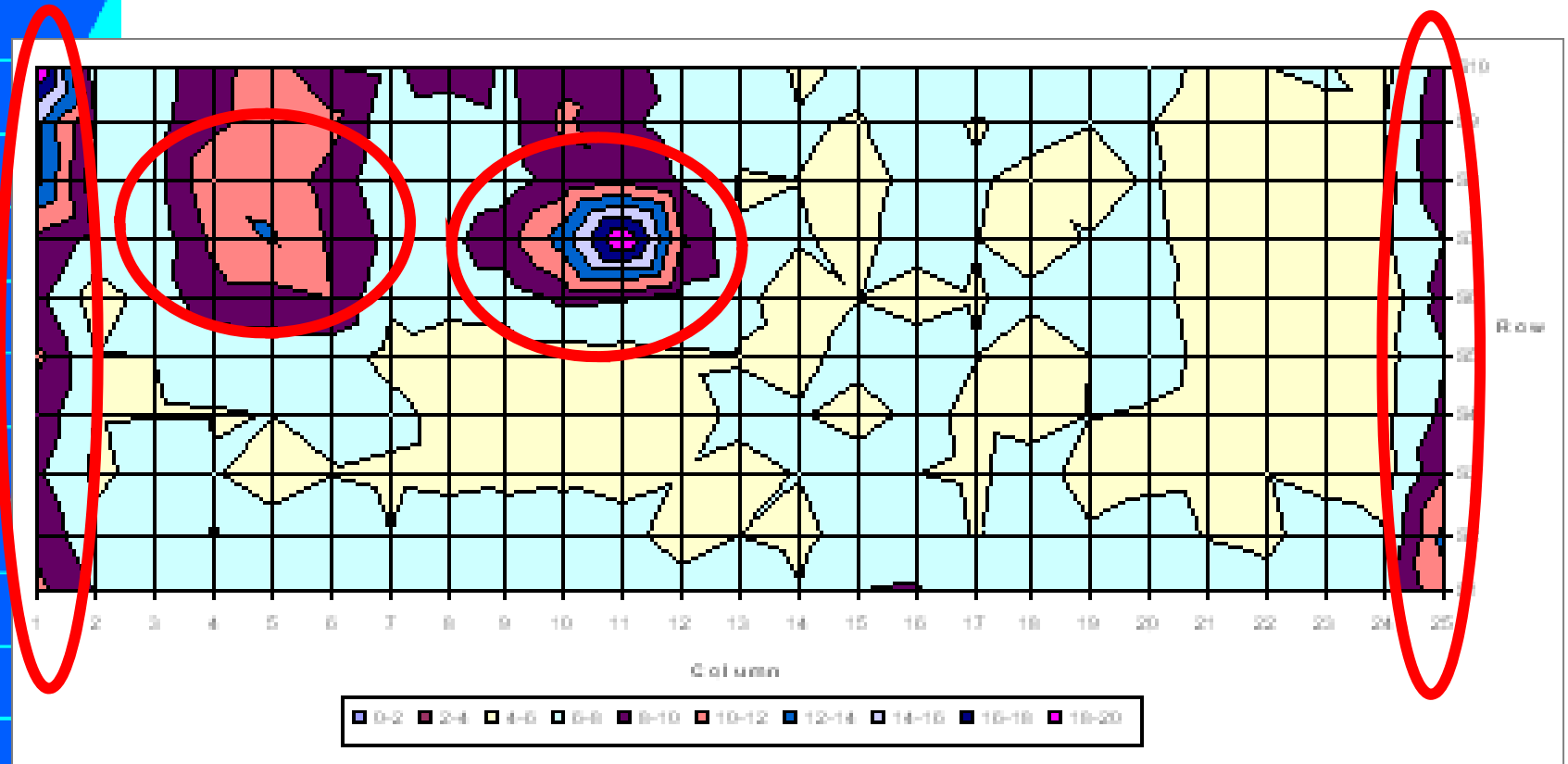

Ultrasonic Echo Methods

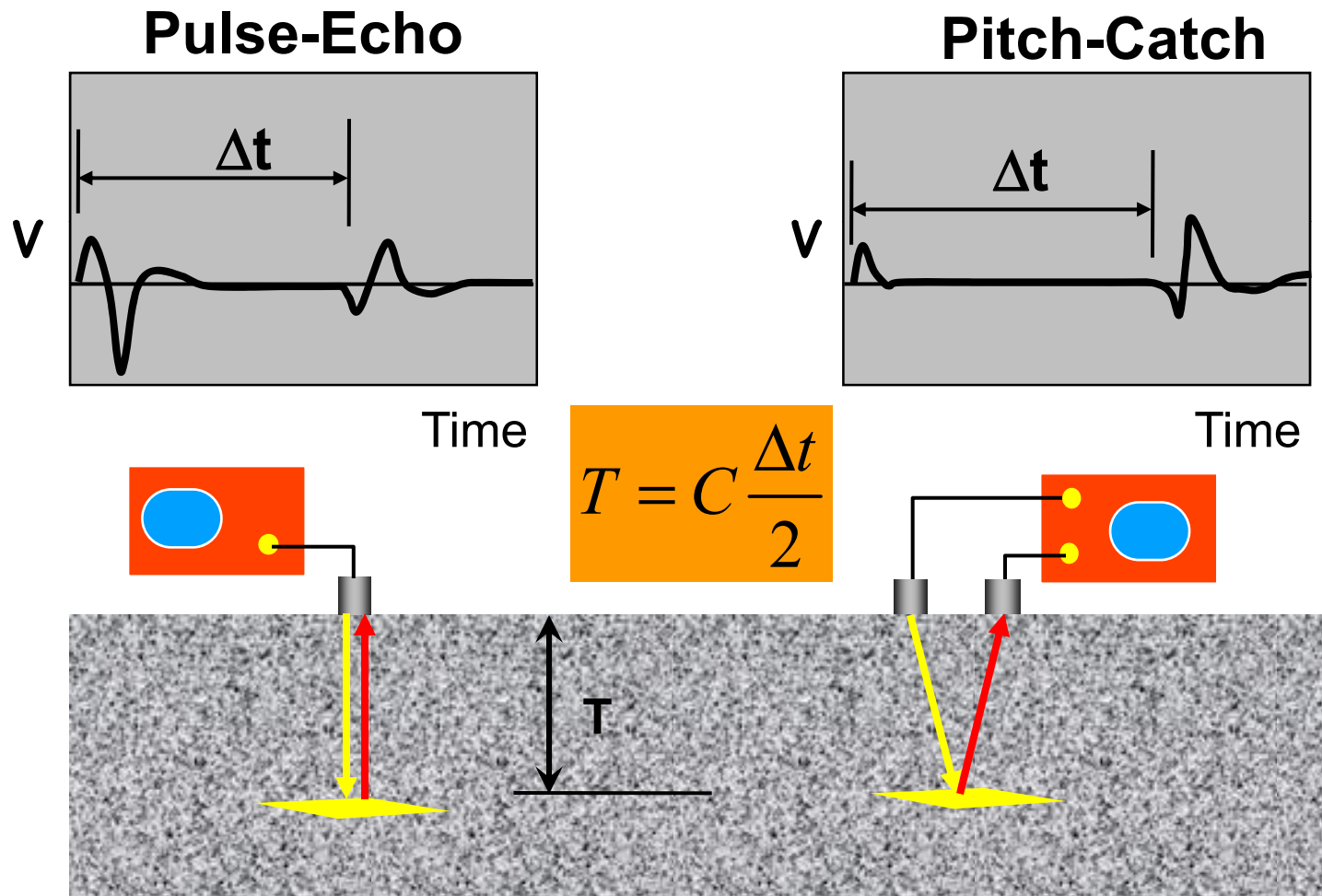



Ultrasonic-Echo Methods

- Limited success before the 1990s
- Developments since the 1990s
 - ◆ Low frequency (50 to 100 kHz), broadband, dry coupled, point transducers
 - Compressional and shear waves
 - ◆ Availability of computing power
 - Use of transducer arrays
 - Digital signal processing
 - Visualization methods

Pulse Shapes

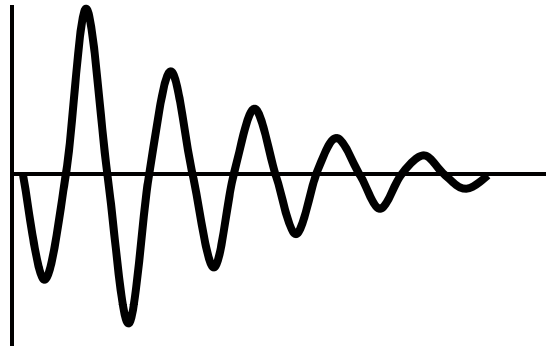

- Lightly damped or narrow band transducer (UPV)

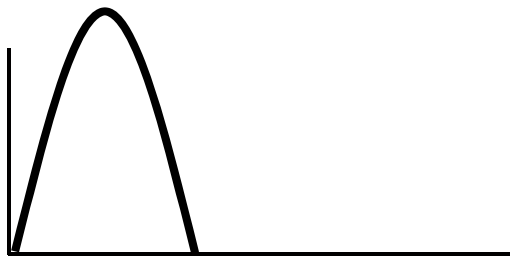

- Impact (I-E)

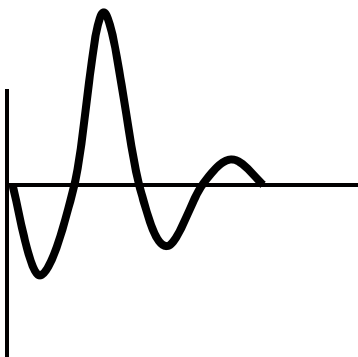

- Damped or broadband transducer (U-E)

Shear-Wave Phased Arrays



EyeCon
4 x 6

MIRA
4 x 10

MIRA

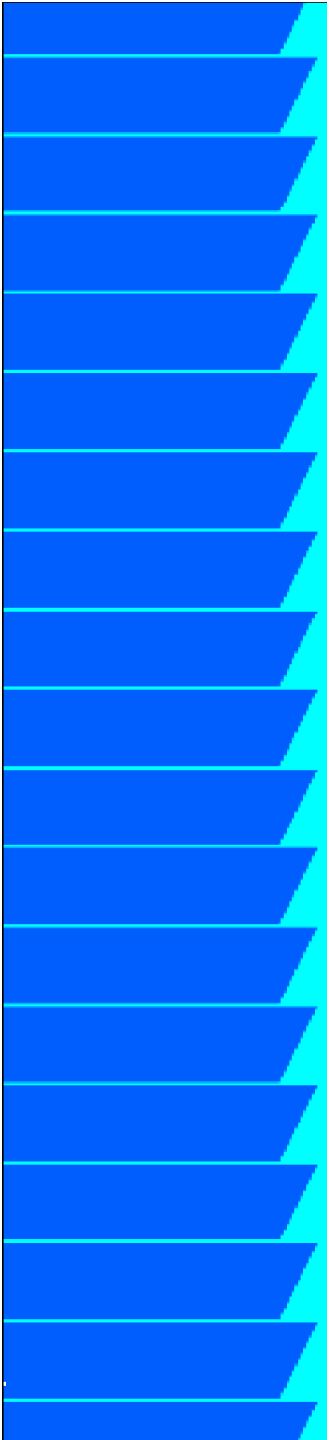

Transducer Array System

Multiple pitch-catch tests

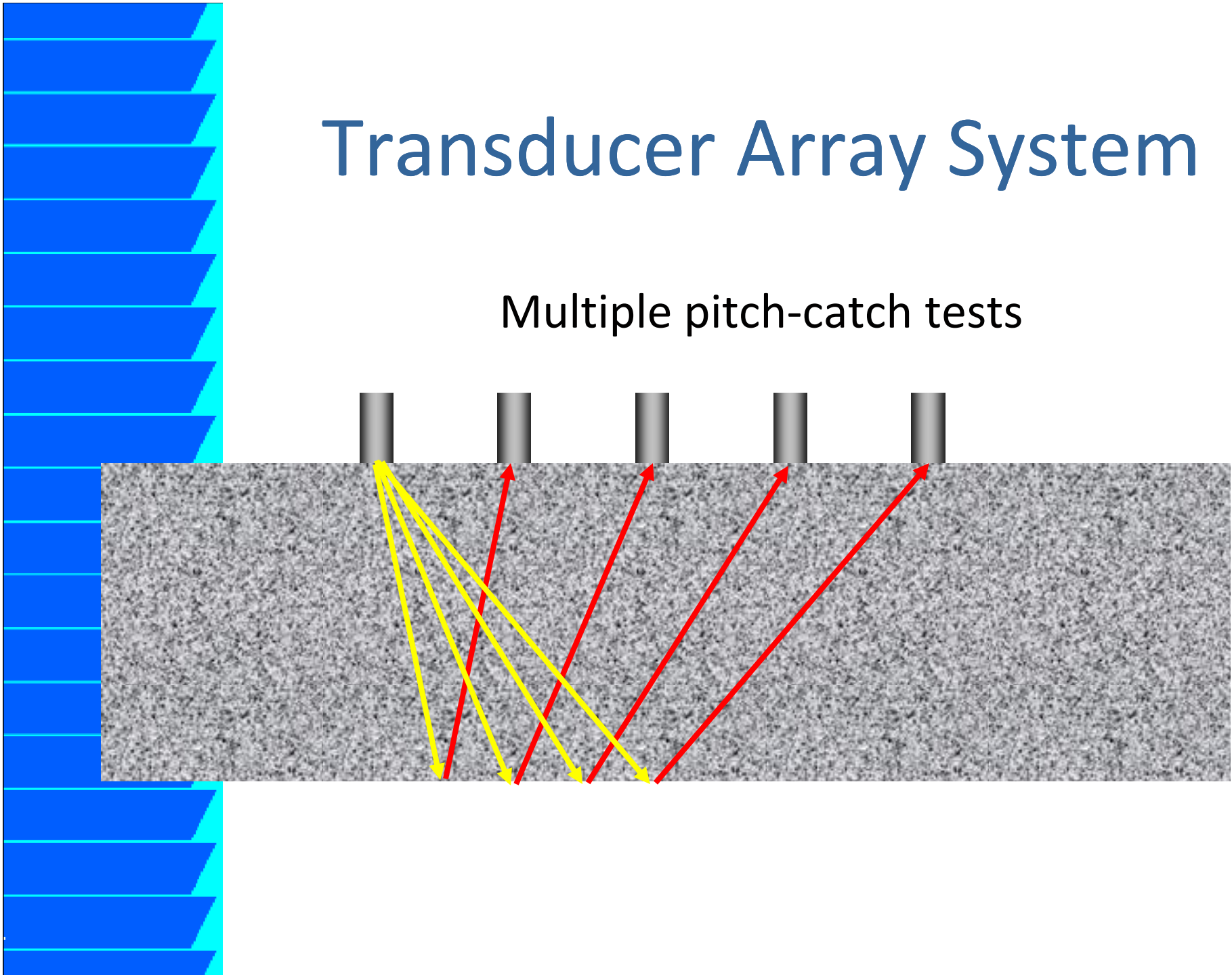

Transducer Array System

Transducers function as transmitters and receivers; results in multiple ray paths

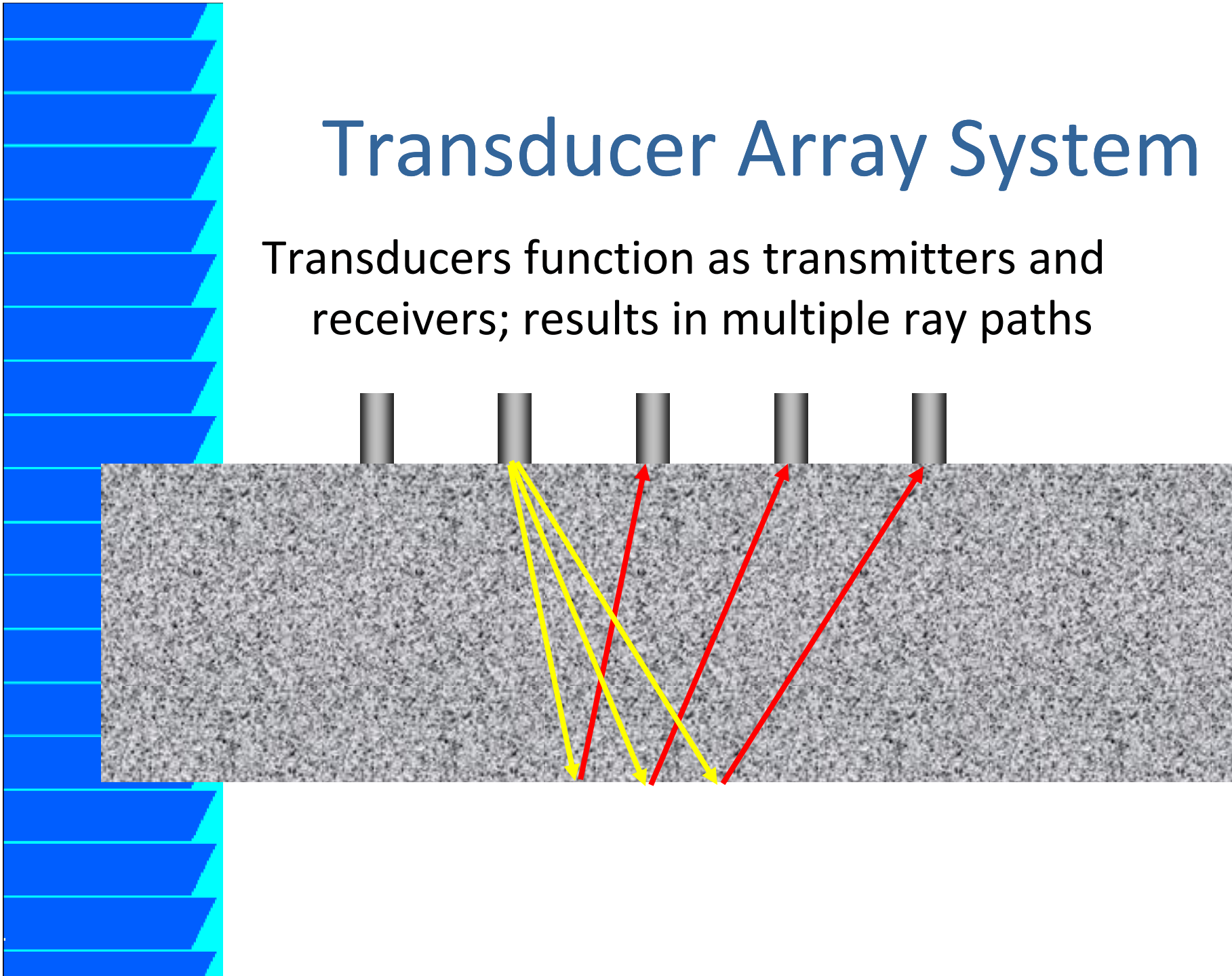

Detection Range

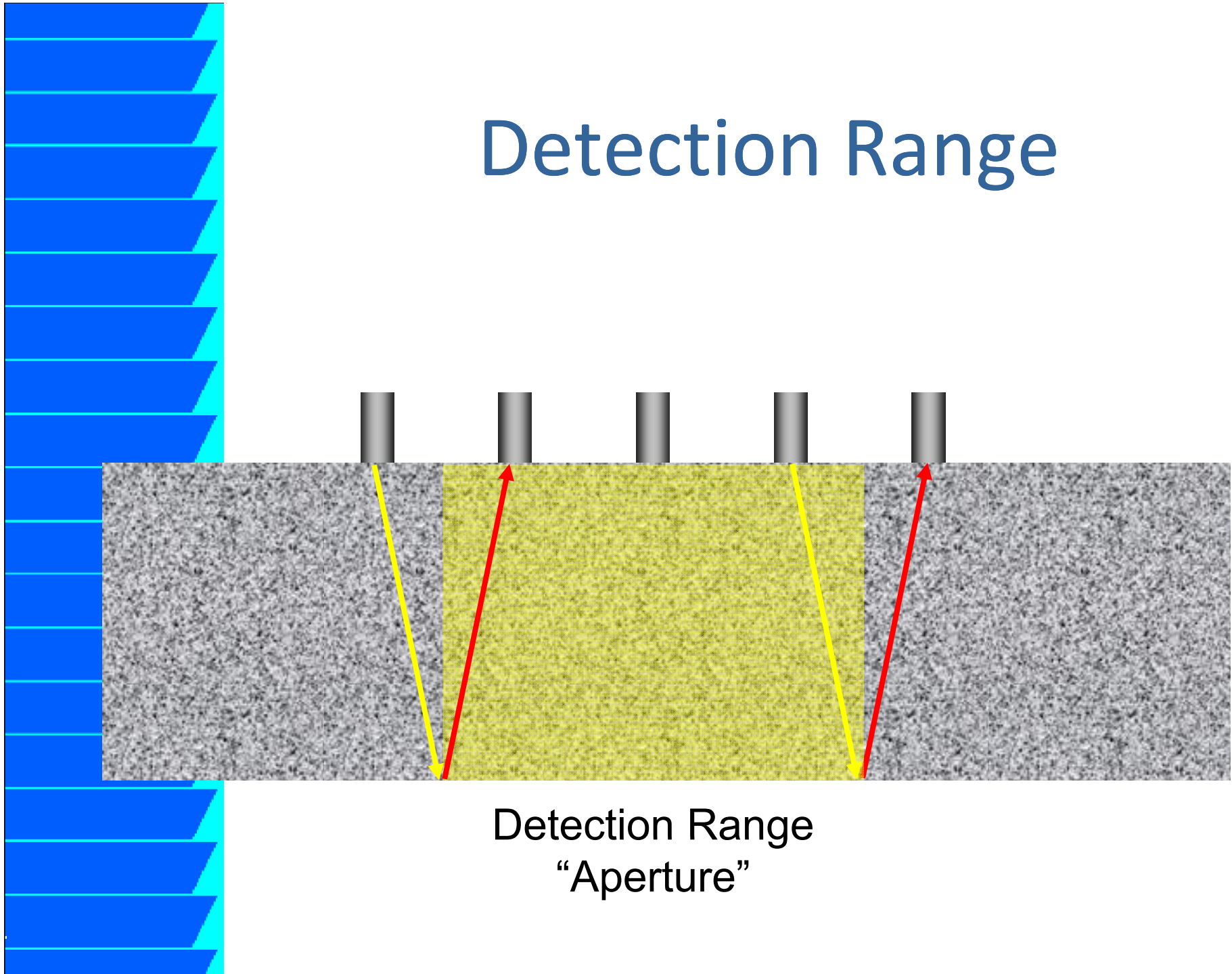

Depth Correction

Depth of reflector based on measured travel time

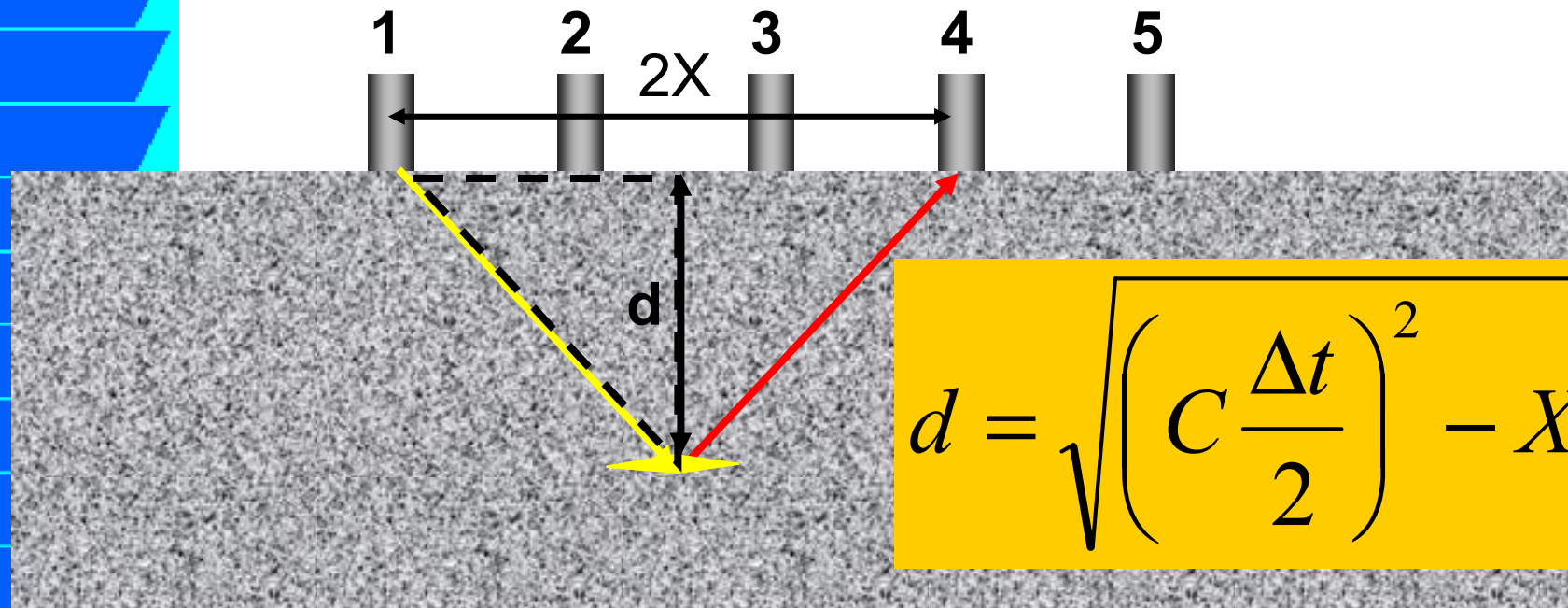

C = wave speed

Δt = total travel time

Transducer Array System

Presence of large reflecting interface results in detection by multiple sensors

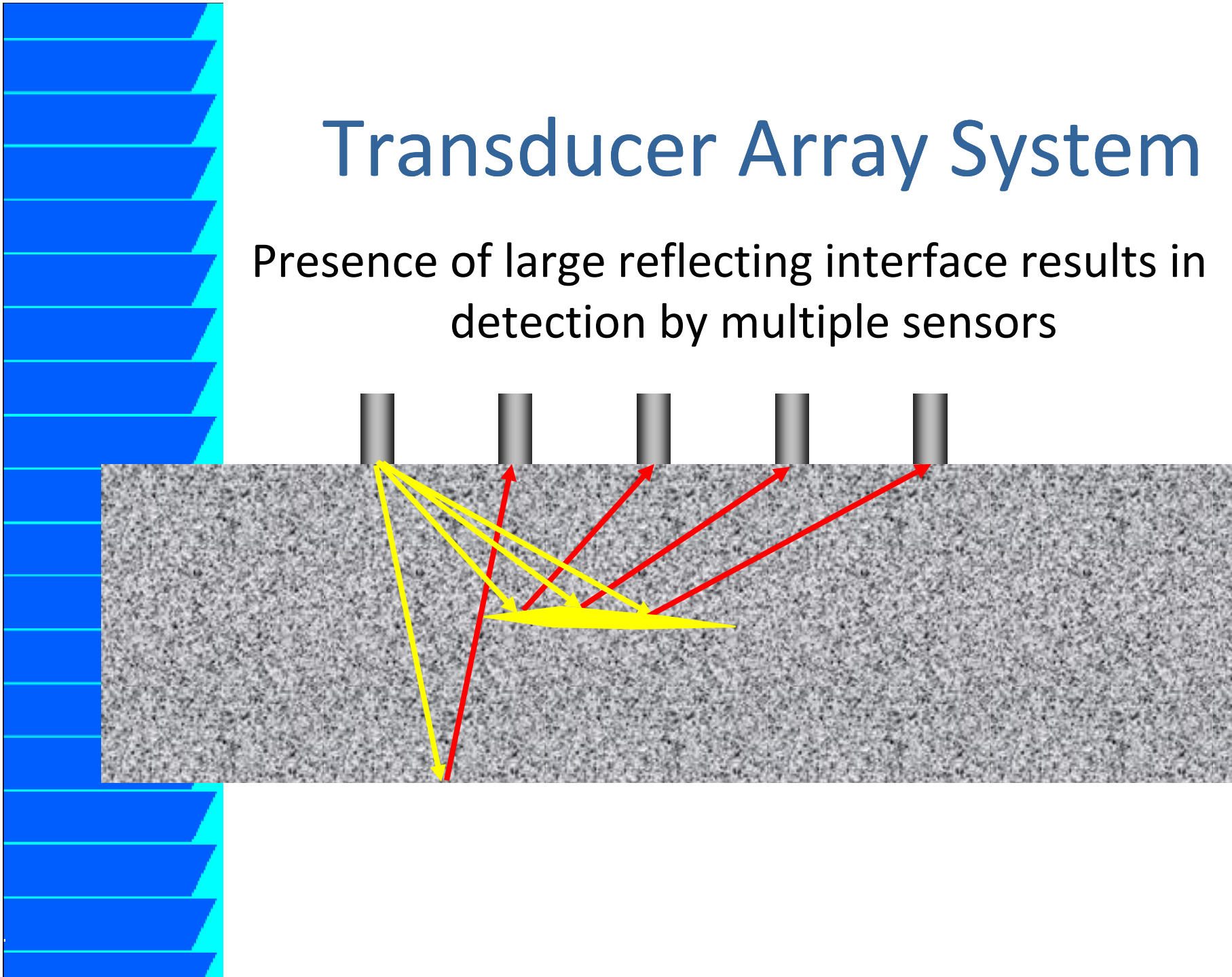

MIRA Antenna

- 4 x 10 transducer array
- $45 \times 4 = 180$ ray paths per scan
- Scan time = 0.35 s

PZT
Elements

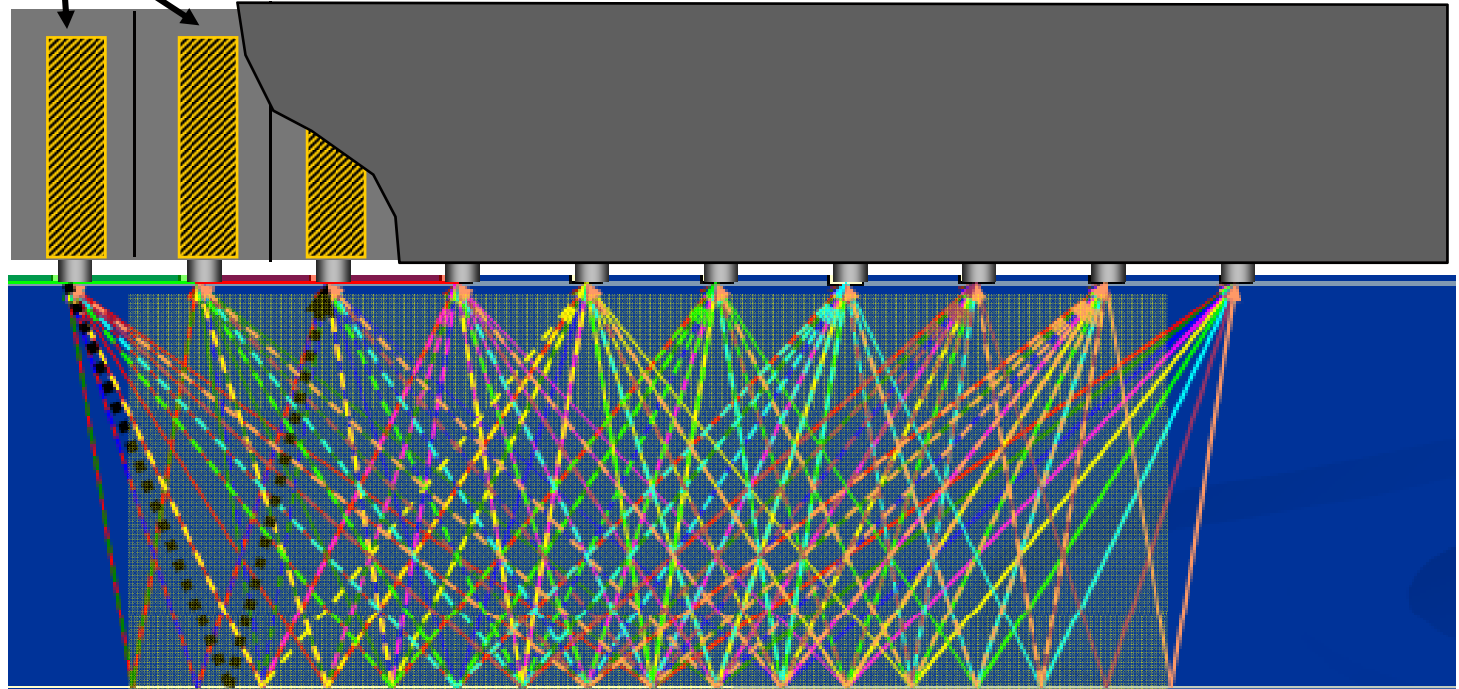

Scanning



2-D Scan

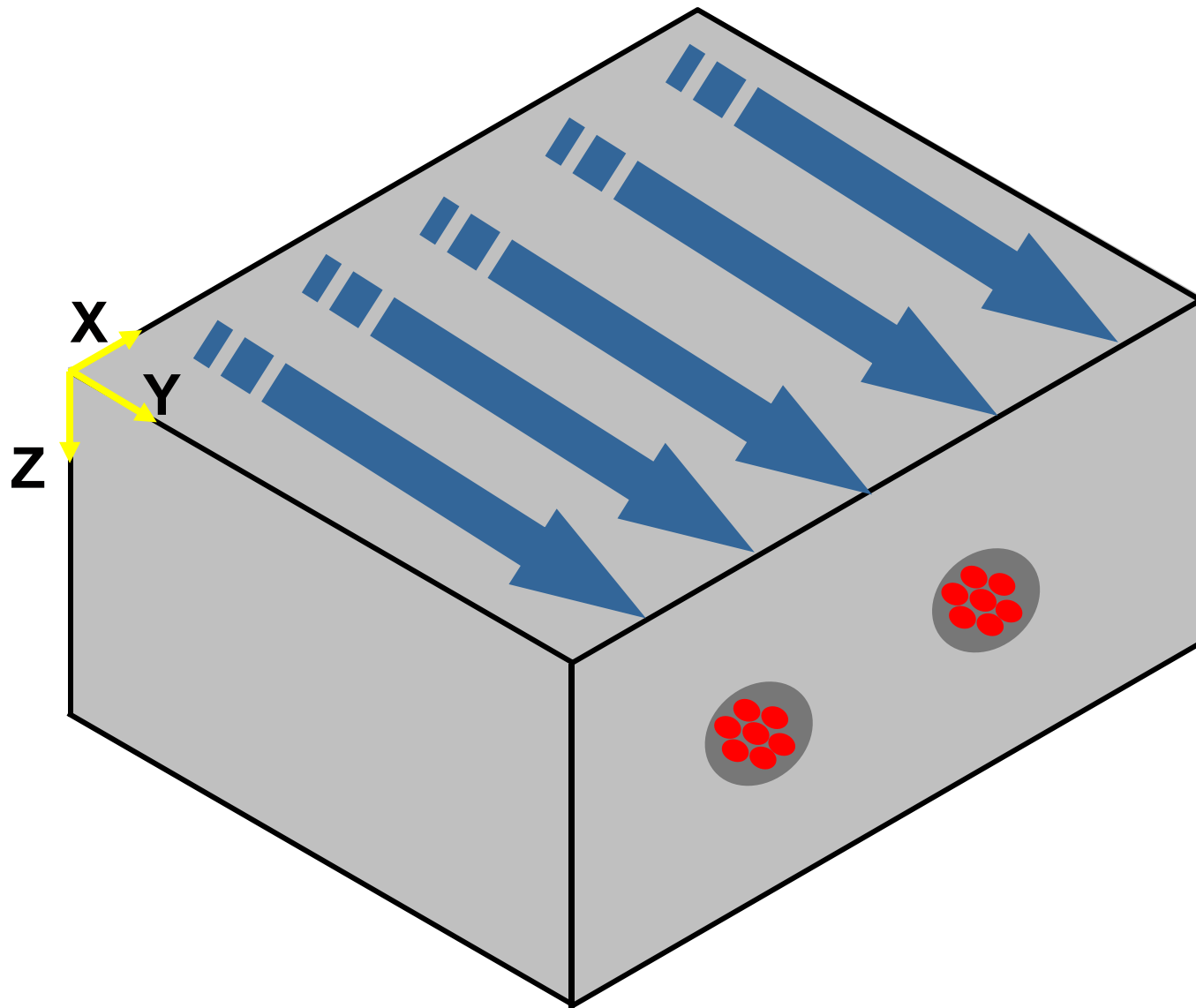
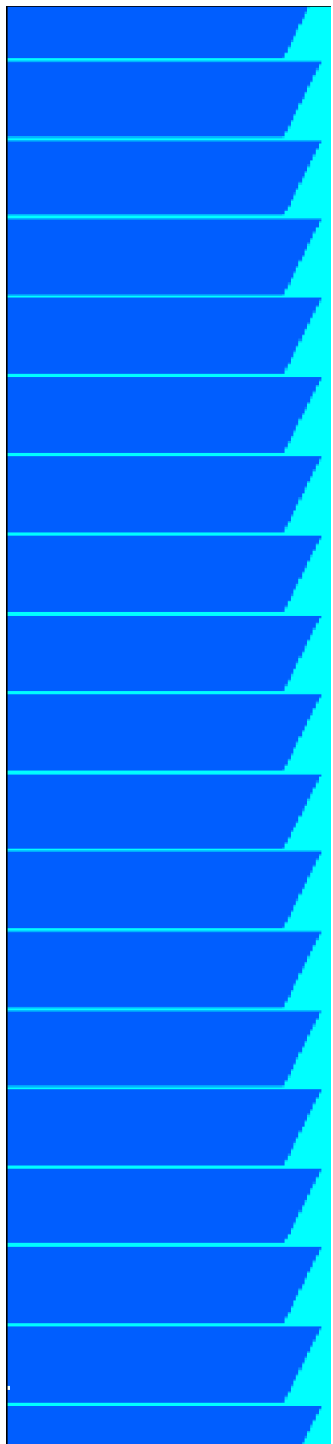



Synthetic Aperture Focusing Technique (SAFT)

- Times of flight obtained from 2-D scan with transducer array are used to reconstruct location of reflecting interfaces
- The result is a 3-D image of the internal reflectors
 - ◆ View in three image planes

Image Planes

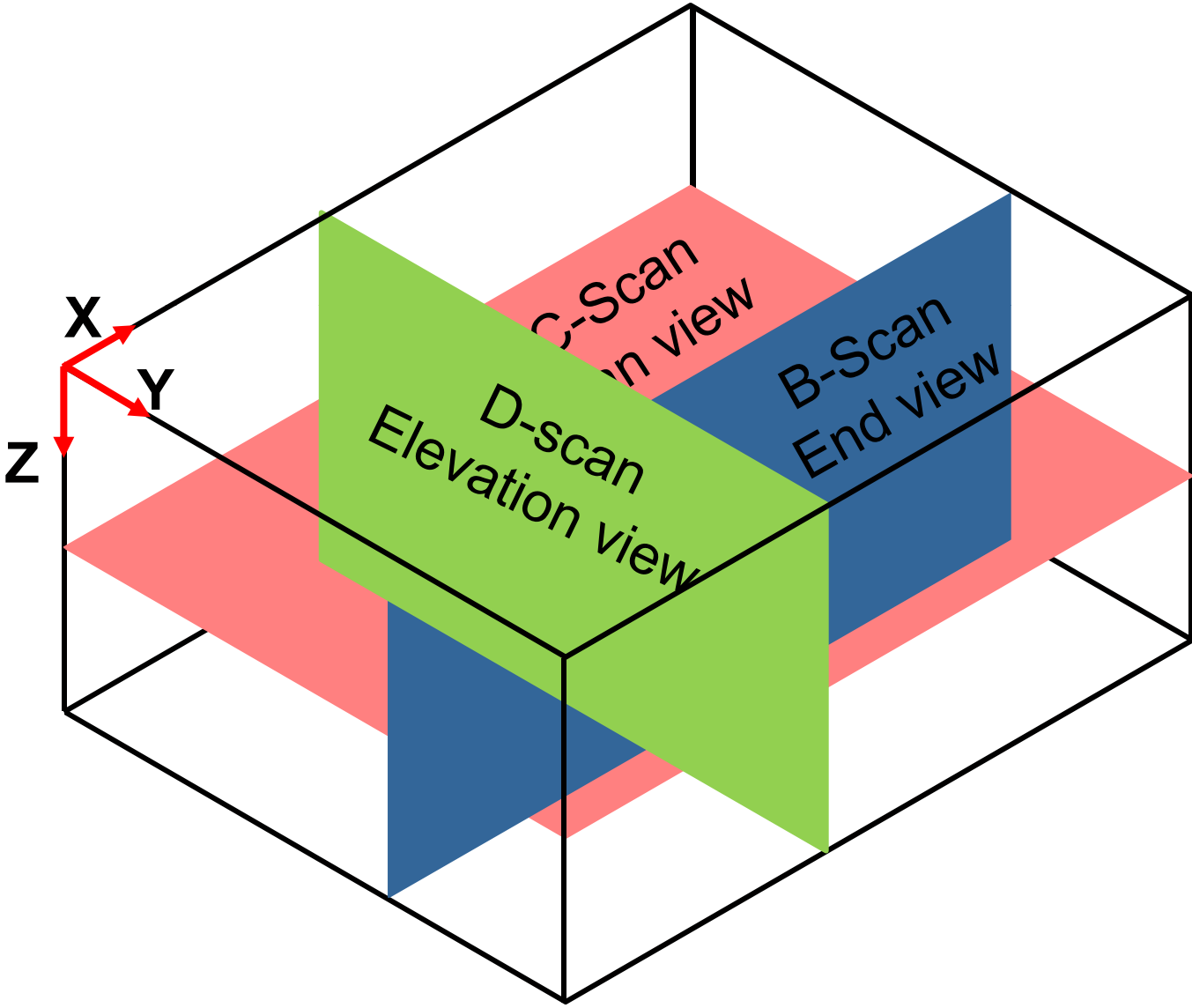
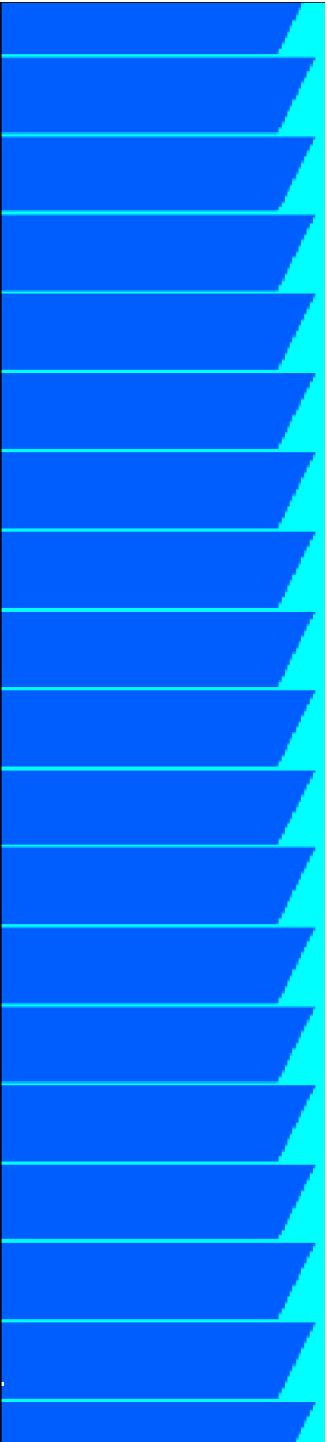

Example

0.8 m x 0.4 m x 0.4 m

$C_s = 2385$ m/s

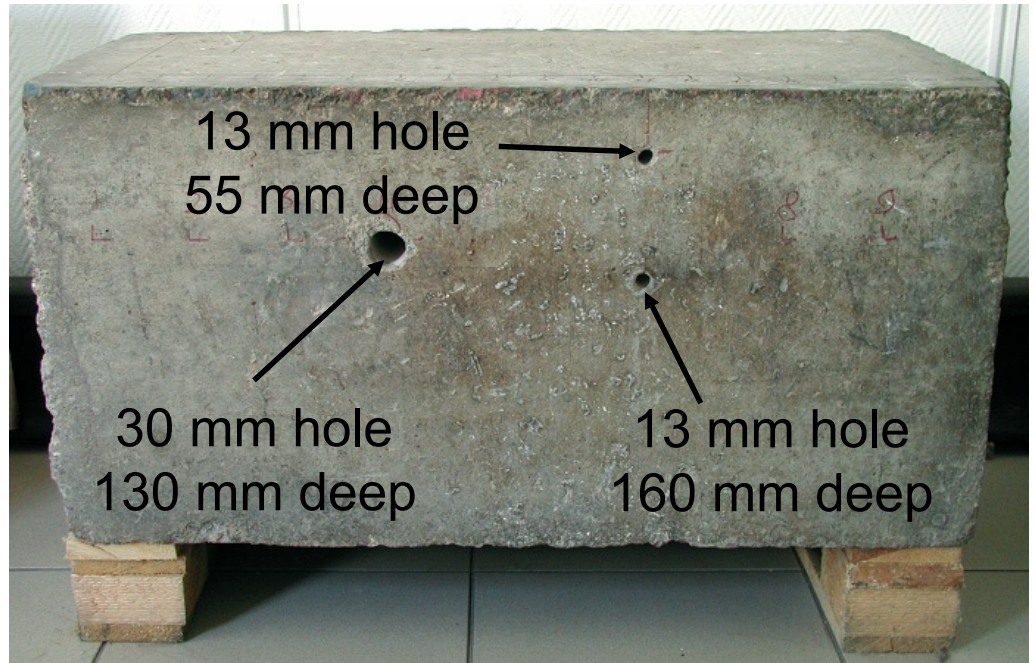

B-Scan

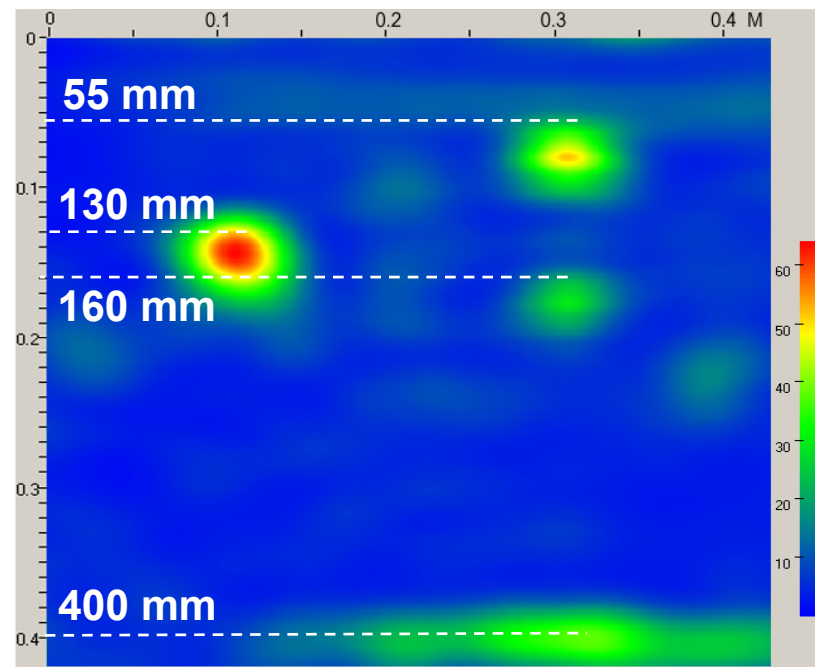
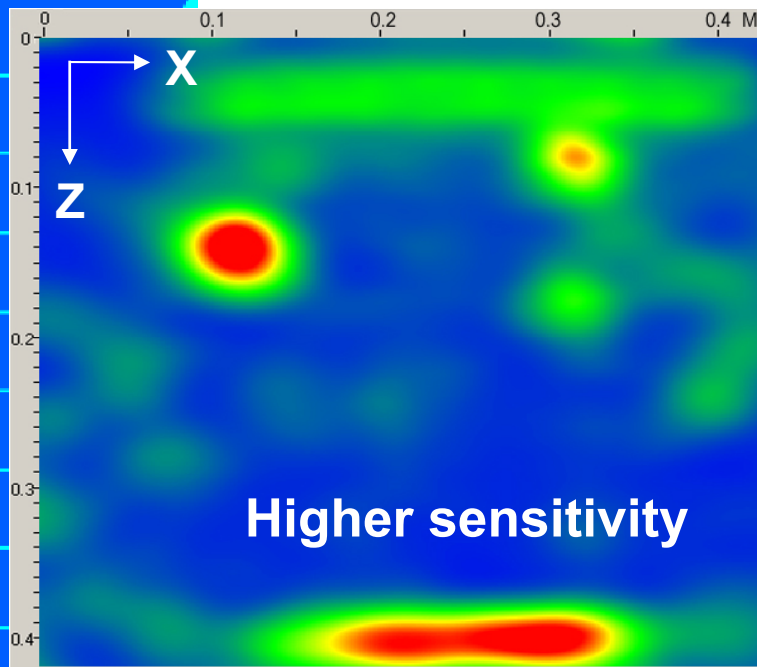

Grouted Tendon Duct

Duct diameter: 60 mm
Cover depth: 80 mm
Slab thickness: 300 mm

NOV 21 2006



D-Scan Elevation

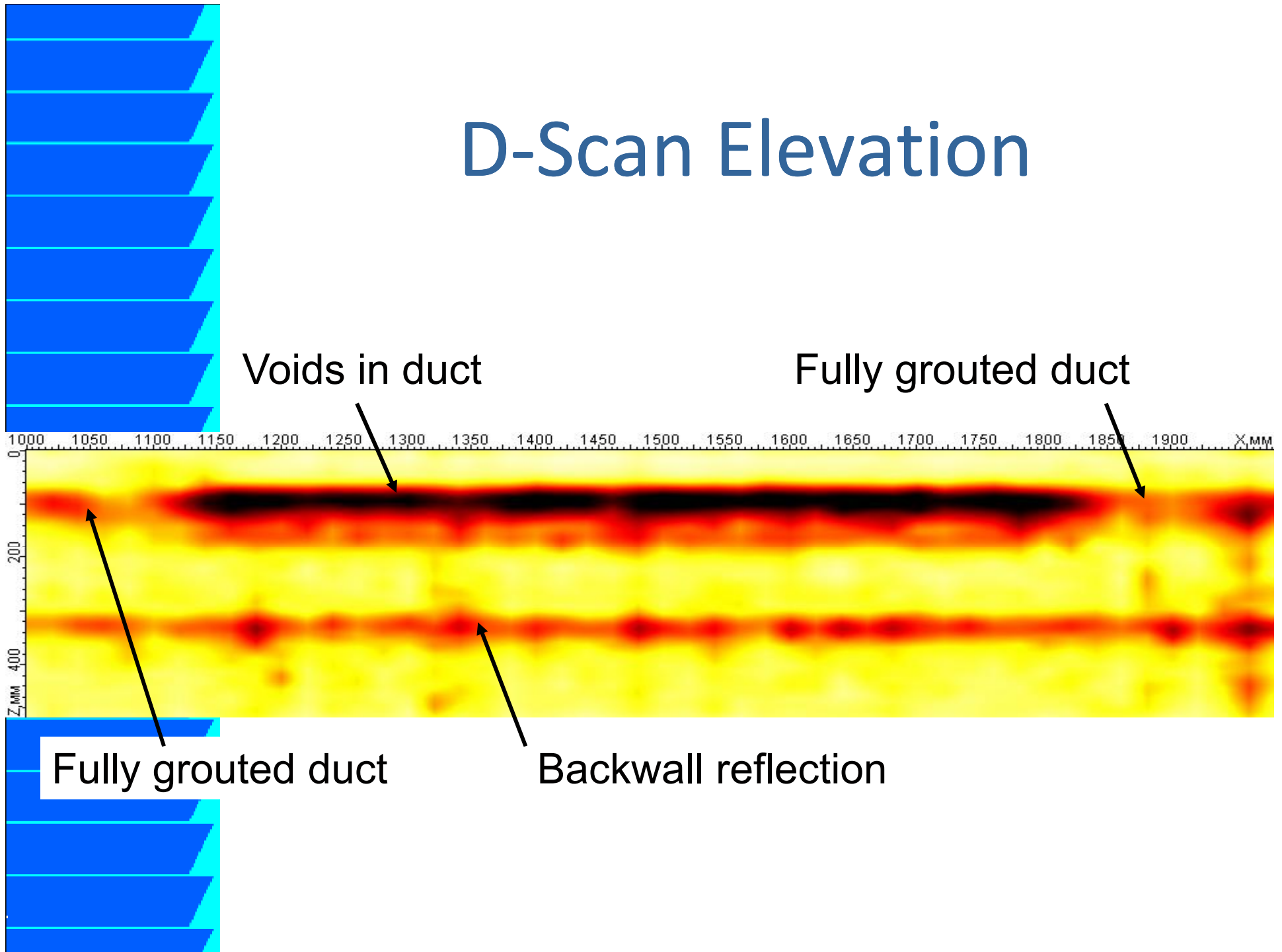



Stress-Wave Methods

- Ultrasonic pulse velocity
- Sounding (chain drag)
- Impact-echo method
- Impulse-response method
- Ultrasonic-echo method



Assessment of Reinforcement

- Location and size
 - ◆ Covermeters
 - ◆ Radar (location)
- Corrosion condition
 - ◆ Half-cell potential (likelihood of corrosion)
 - ◆ Polarization resistance (corrosion rate)
 - ◆ Concrete resistivity
 - ◆ Depth of carbonation
 - ◆ Chloride ion concentration

Reinforcement Corrosion

- Anodic and cathodic sites exist on bar
- Iron goes into solution at active sites (anode)
- Electrons travel through bar and iron ions travel through concrete
- Rust forms rust at cathode

Anodic Reaction:



Cathodic Reaction:

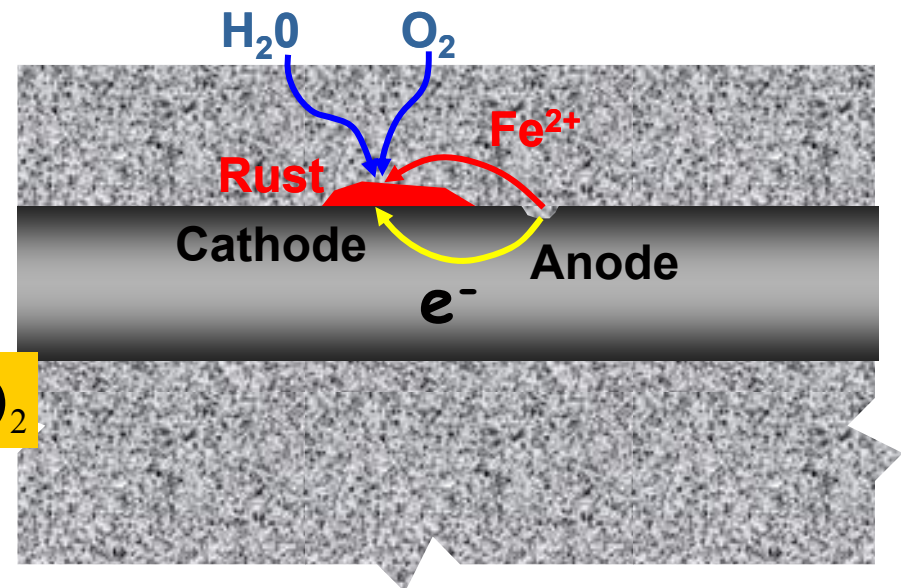
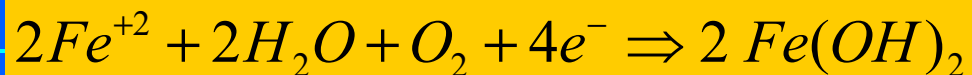



Half-Cell Potential Method

ASTM C876

- When bar is corroding, charge flow through concrete is associated with an electrical field
- Measure the electrical potential (voltage) of the field at the concrete surface
- Magnitude of the measured voltage, relative to a standard half-cell, is indicative of corrosion activity
- Higher voltage indicates **higher likelihood** of active corrosion

Potential Field

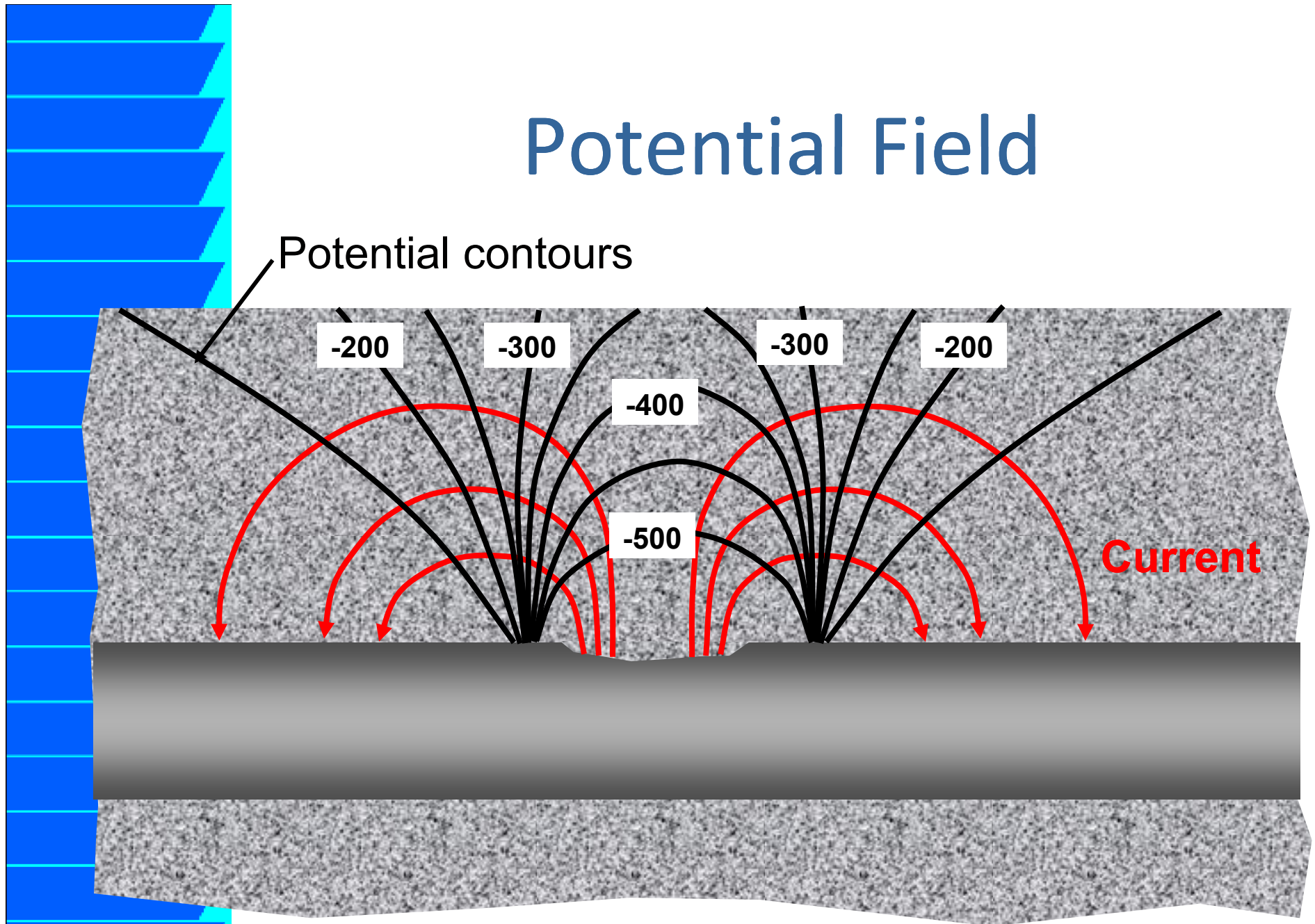

Elsner and Bohni, *ASTM STP 1065*, 1990

Half-Cell Potential Method ASTM C876

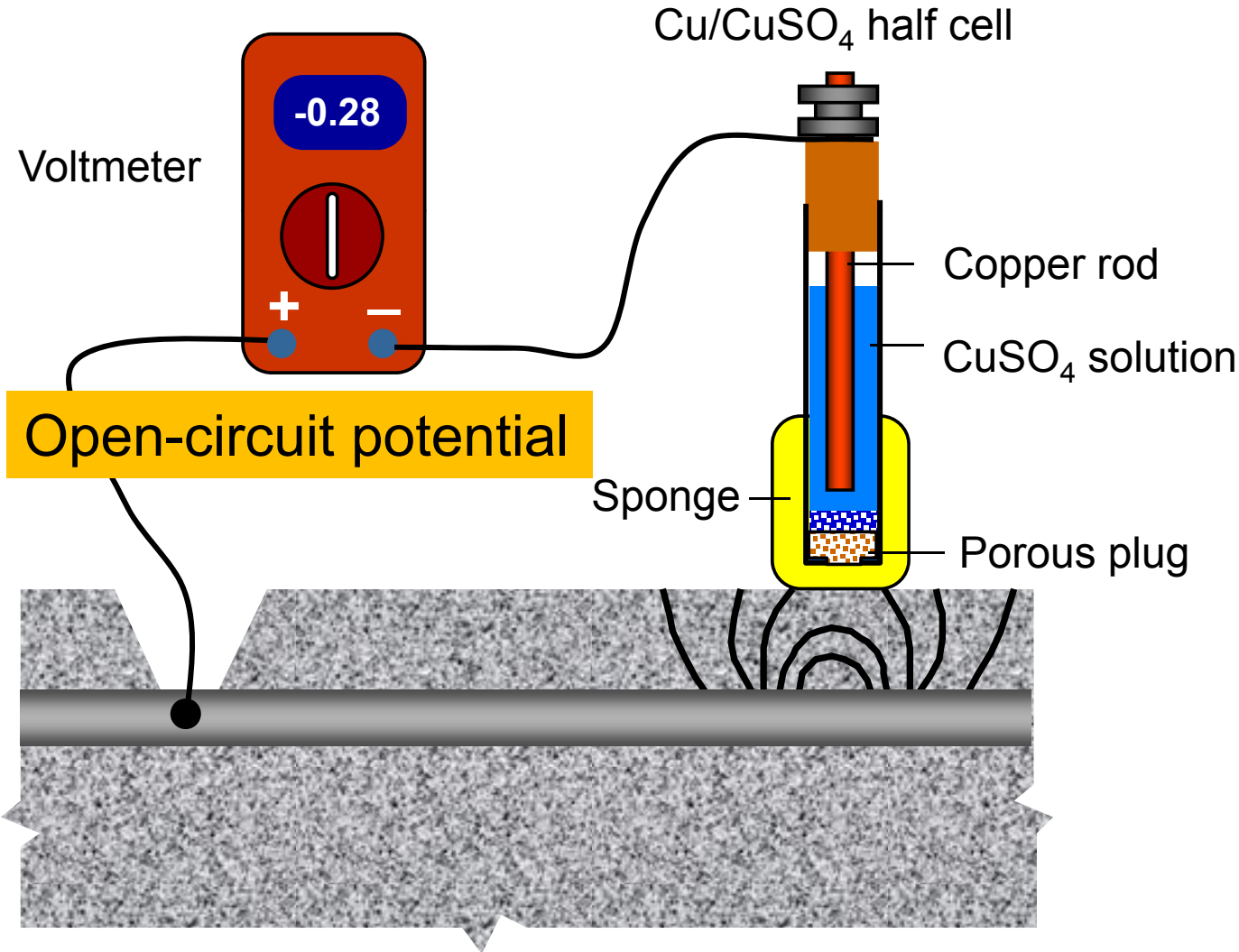

Example



Proceq SA

Half-Cell Potential Contour Plot

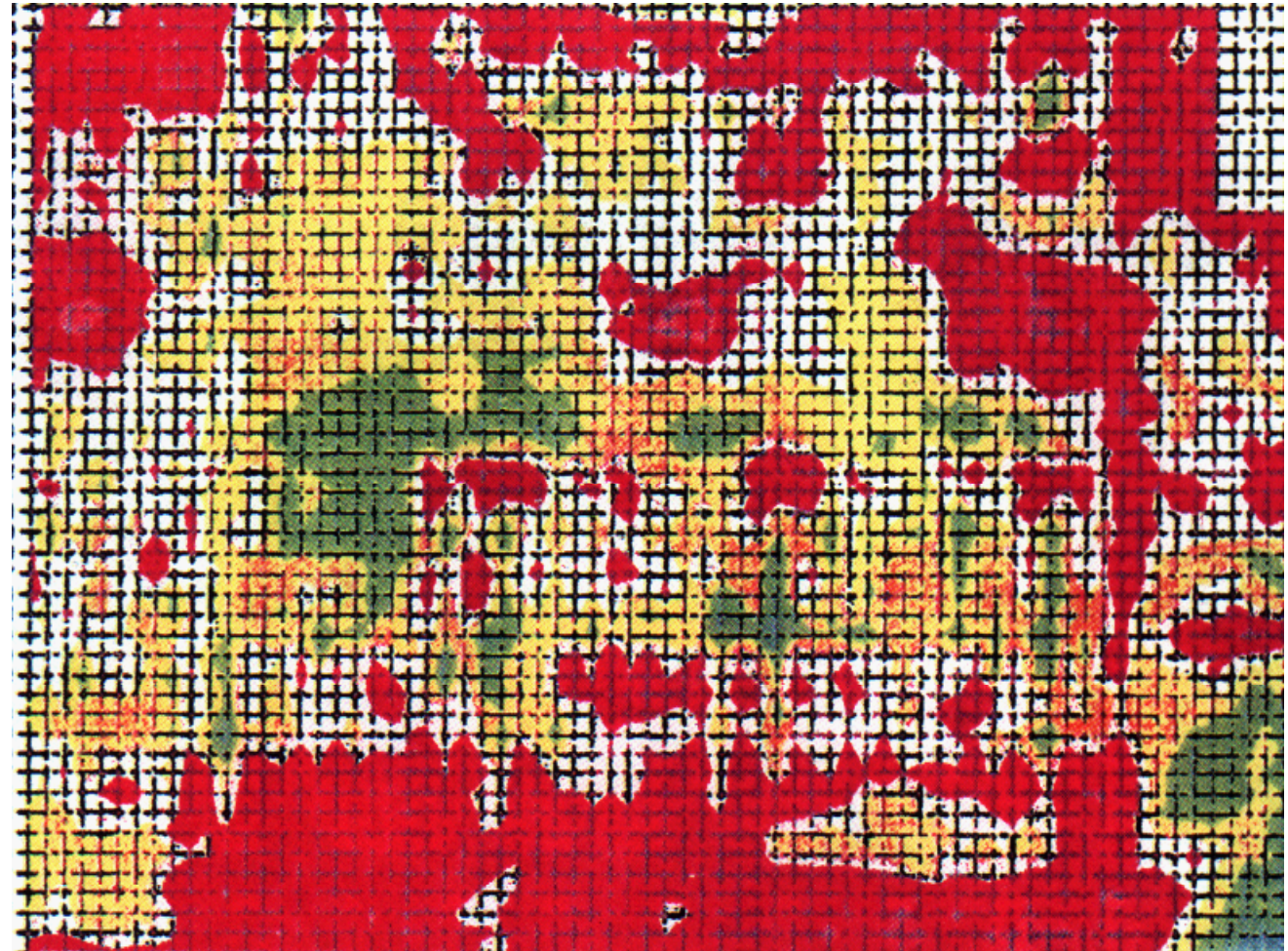
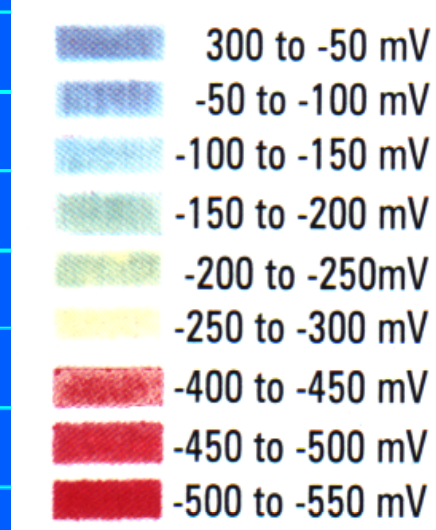

J. Woodhouse, "Quantifying the Invisible," *Concrete Repair Bulletin*,
July/August 1996



Considerations

- Concrete must be sufficiently moist
 - ◆ ASTM C876 provides criterion
- Provides only indication of **likelihood** of active corrosion
 - ◆ More positive than -200 mV: **corrosion unlikely**
 - ◆ More negative than -350 mV: **corrosion likely**
 - ◆ -200 to -350 mV: **???????**
- Other factors have to be considered (see ASTM C876)



Polarization Resistance

- **Half-cell potential** provides information on **likelihood** that corrosion is occurring
- **Polarization resistance** provides indication of **corrosion current** (or corrosion rate)
 - ◆ At the time of testing
 - ◆ Rate affected by in-place conditions (moisture, oxygen, temperature)



Polarization

- Change from the open-circuit potential as a result of passage of current
- A bar that is **actively corroding** will have **small change in potential** when **external current** is applied to the bar



Polarization Resistance Apparatus

- **Working electrode** - the reinforcing bar
- **Counter electrode** - provides current flow to bar
- **Reference electrode** – measure change in potential
- Polarization system
 - ◆ Current supply
 - ◆ Voltmeter
 - ◆ Ammeter
- Hardware and software to acquire and analyze data

Polarization Resistance 3LP

- Measure open circuit potential, E_o

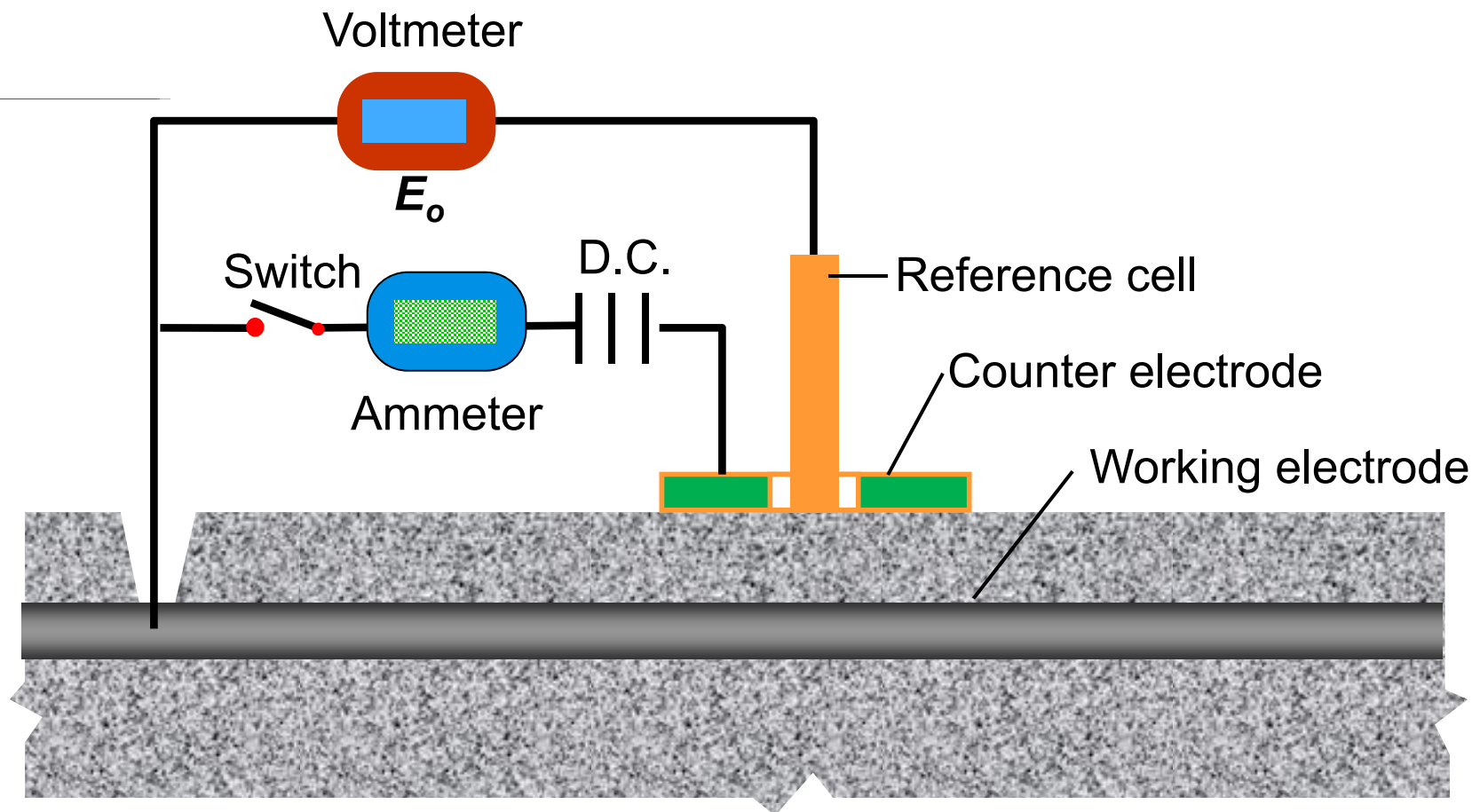

- Close switch and apply small current, I_p
- Measure change in voltage
- Increase current, and repeat measurement
- Divide current by area of bar that is polarized, i_p
- Plot voltage vs. current density

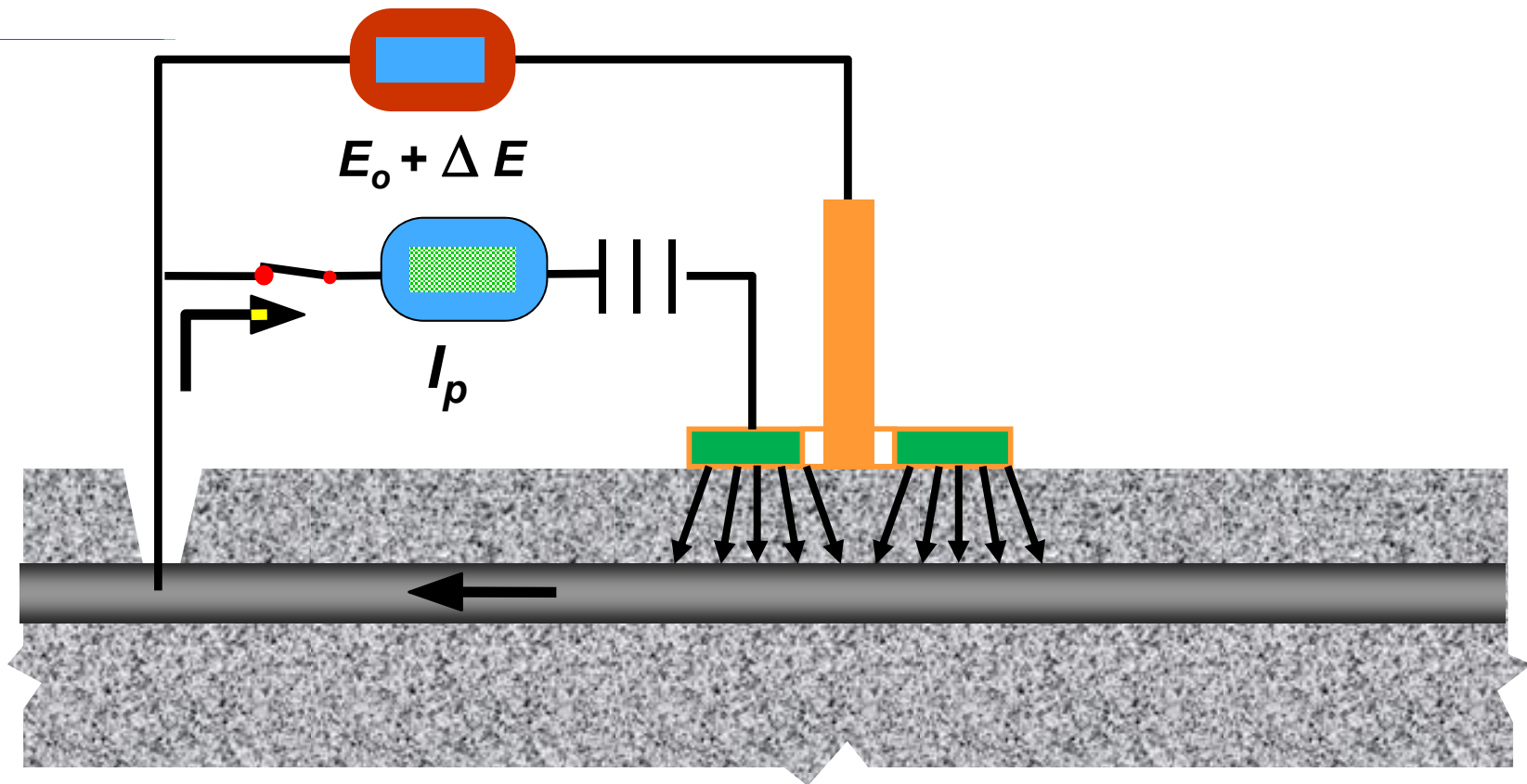

Polarization Resistance, R_p

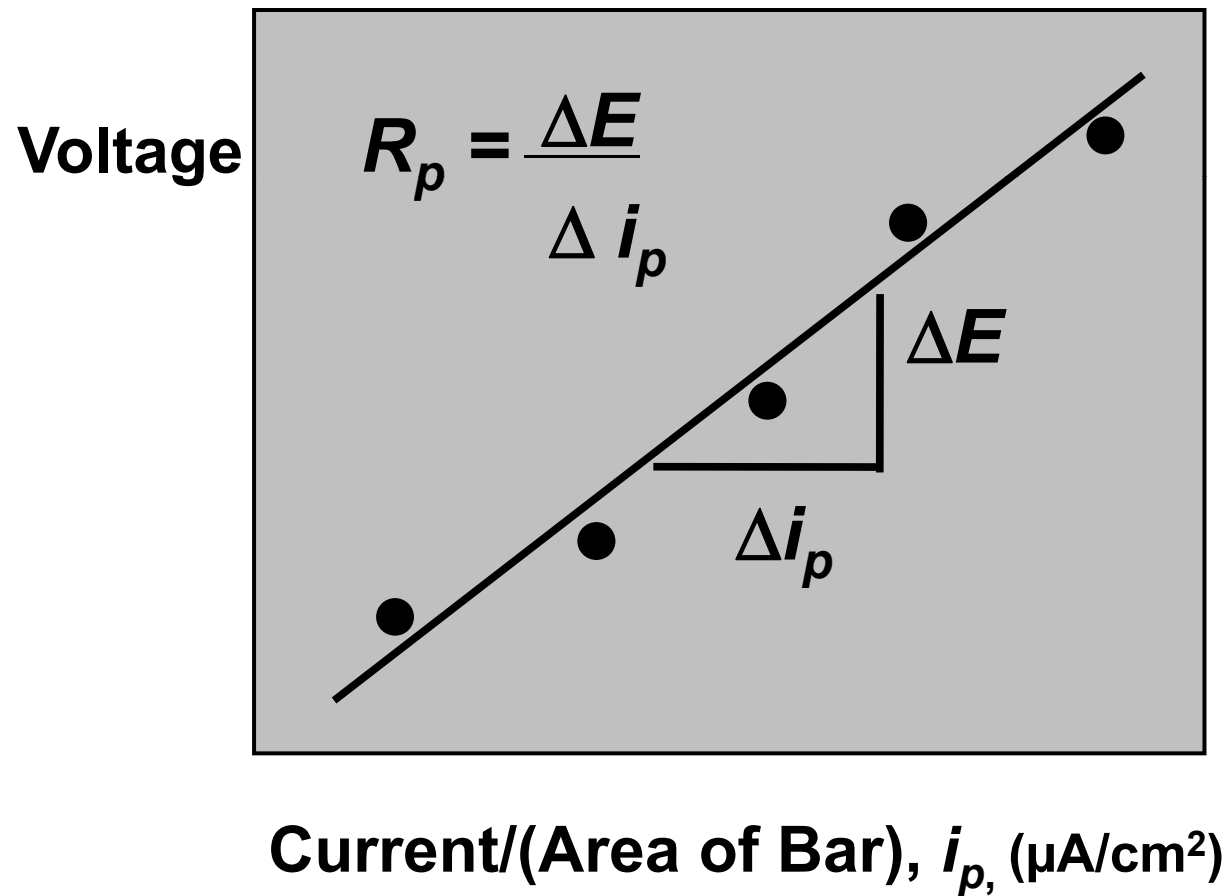



Corrosion Rate

- **Stern-Geary** corrosion rate relationship:

$$i_{corr} = \frac{B}{R_p} \text{ (}\mu\text{A/cm}^2\text{)}$$

$B = 25 \text{ to } 50 \text{ mV}$
(active less active)

- **Faraday' law** can be used to convert i_{corr} to uniform metal loss:

$$1 \mu\text{A/cm}^2 = 0.012 \text{ mm/y}$$



Guard Electrode

- Current density is based on area of bar that is polarized by applied current
- Area of steel that is polarized is not well known in 3LP method
- Use of outer (guard) electrode confines current to portion of bar below guard ring
- Results in more accurate measure of current density

Guard-Electrode Method

Confines current so that polarized area of bar is well defined

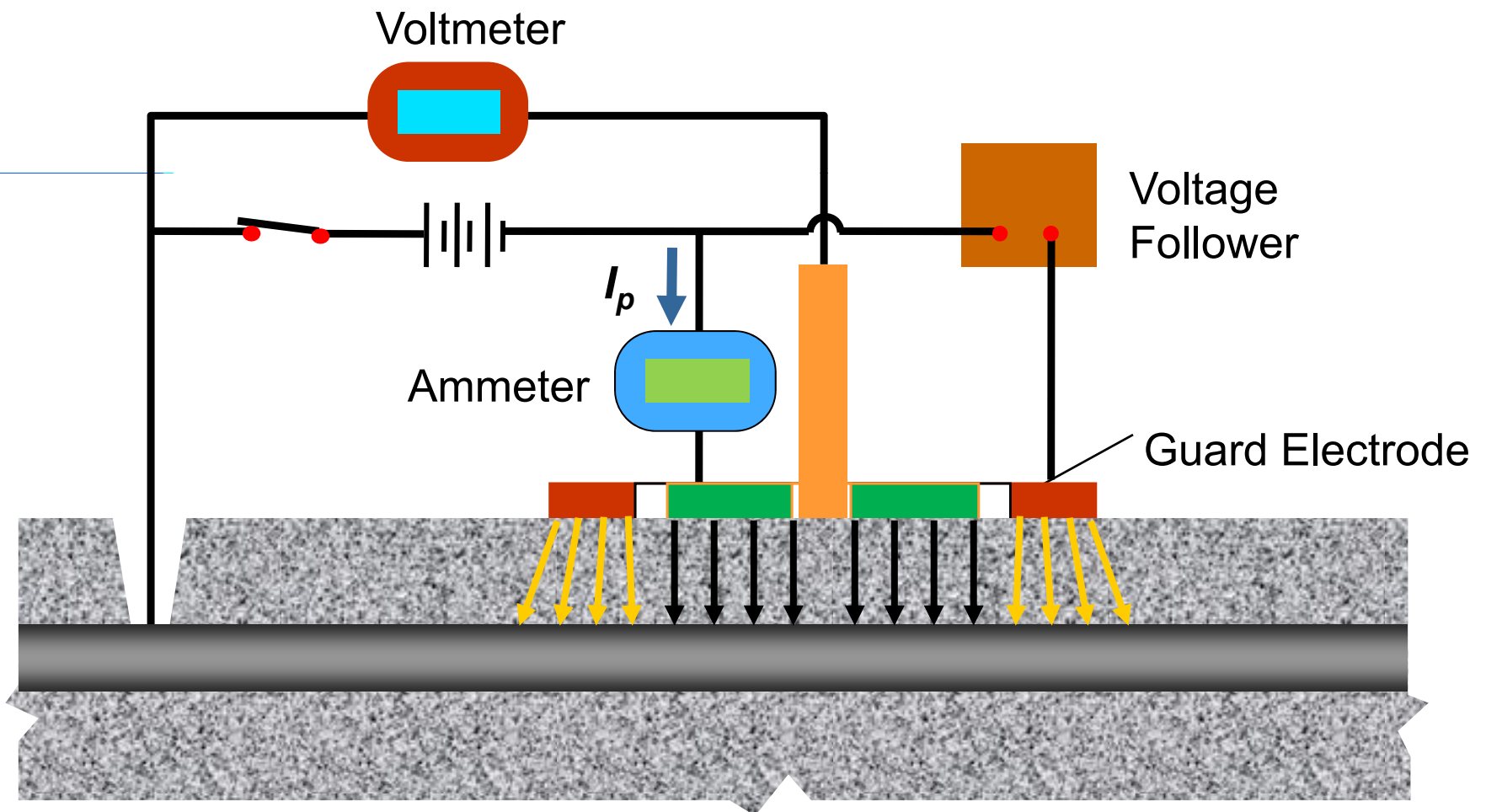

Example of Guard-Electrode



Computer

Guard Electrode
Counter Electrode

Resistivity Probe

James Instruments



Static vs. Pulse Methods

- The polarization resistance technique that has been discussed is time consuming; 3 to 5 min at each point
 - ◆ Voltage (or current) is increased in several steps
 - ◆ Equilibrium conditions need to be established at each step
- Pulsed methods allow faster measurement



Galvanic Pulse Method

- Apply constant current pulse (≈ 10 s)
- Guard electrode is used
- Monitor potential change of working electrode (bar)
- From recorded voltage history, evaluate polarization resistance, R_p , by regression analysis
 - ◆ Assumes Randles equivalent circuit to represent corrosion activity

Randles Equivalent Circuit

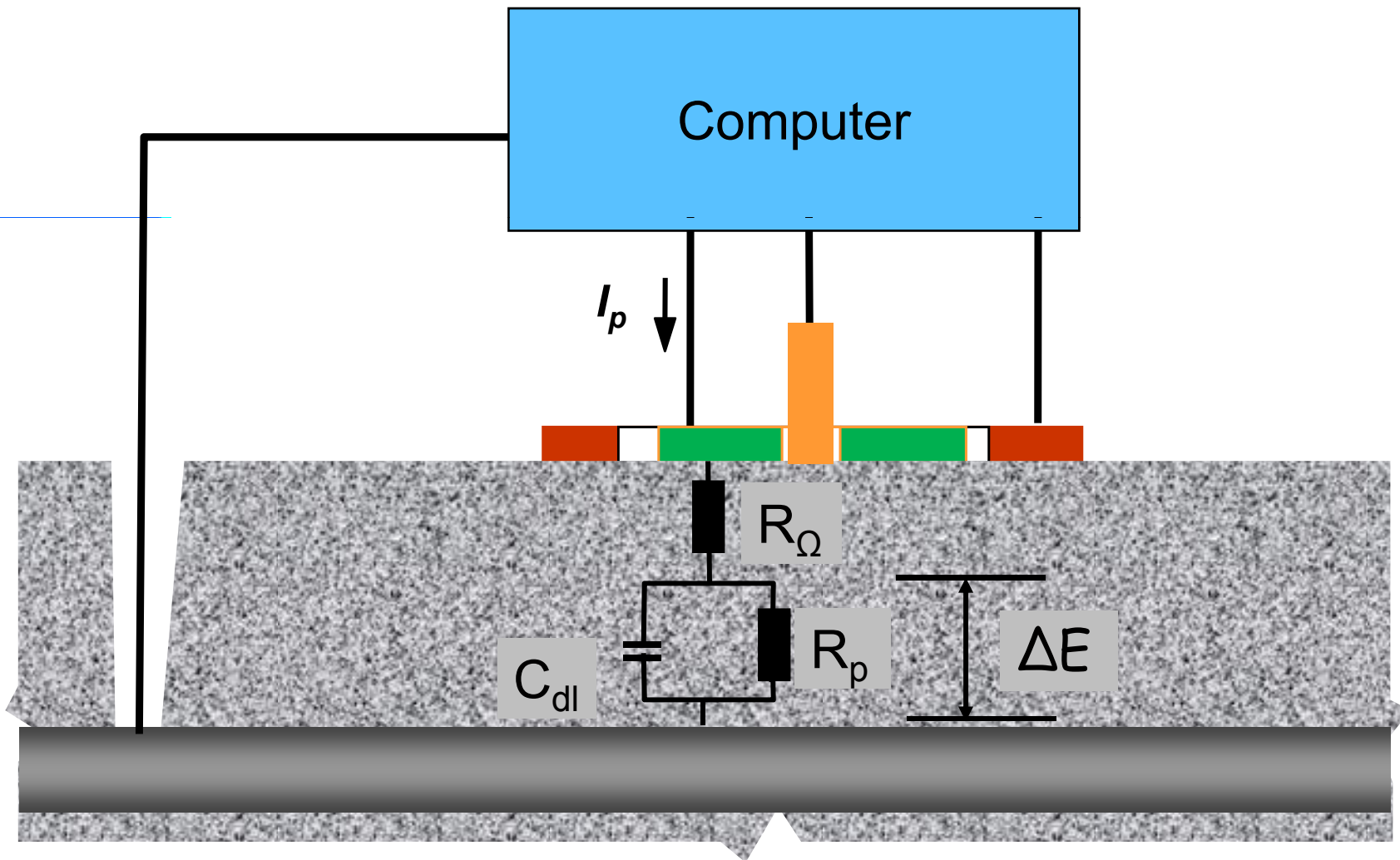

Voltage-Time Curve

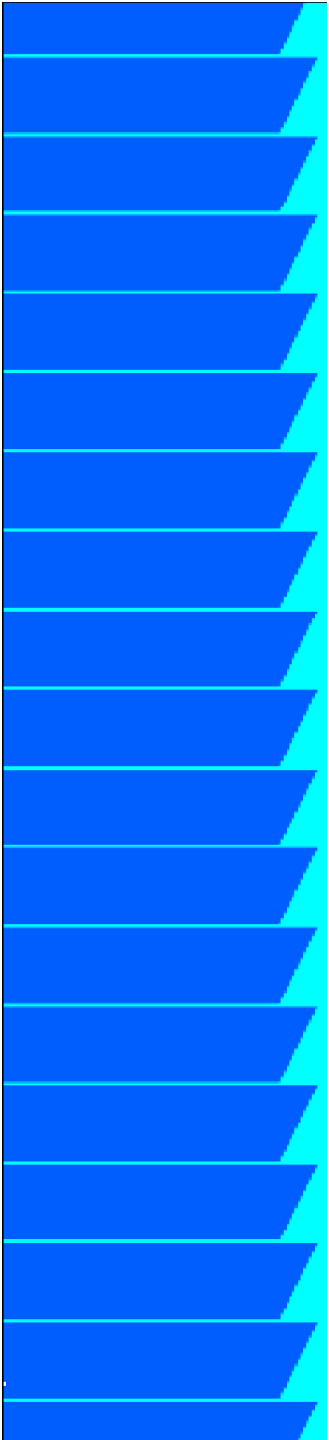
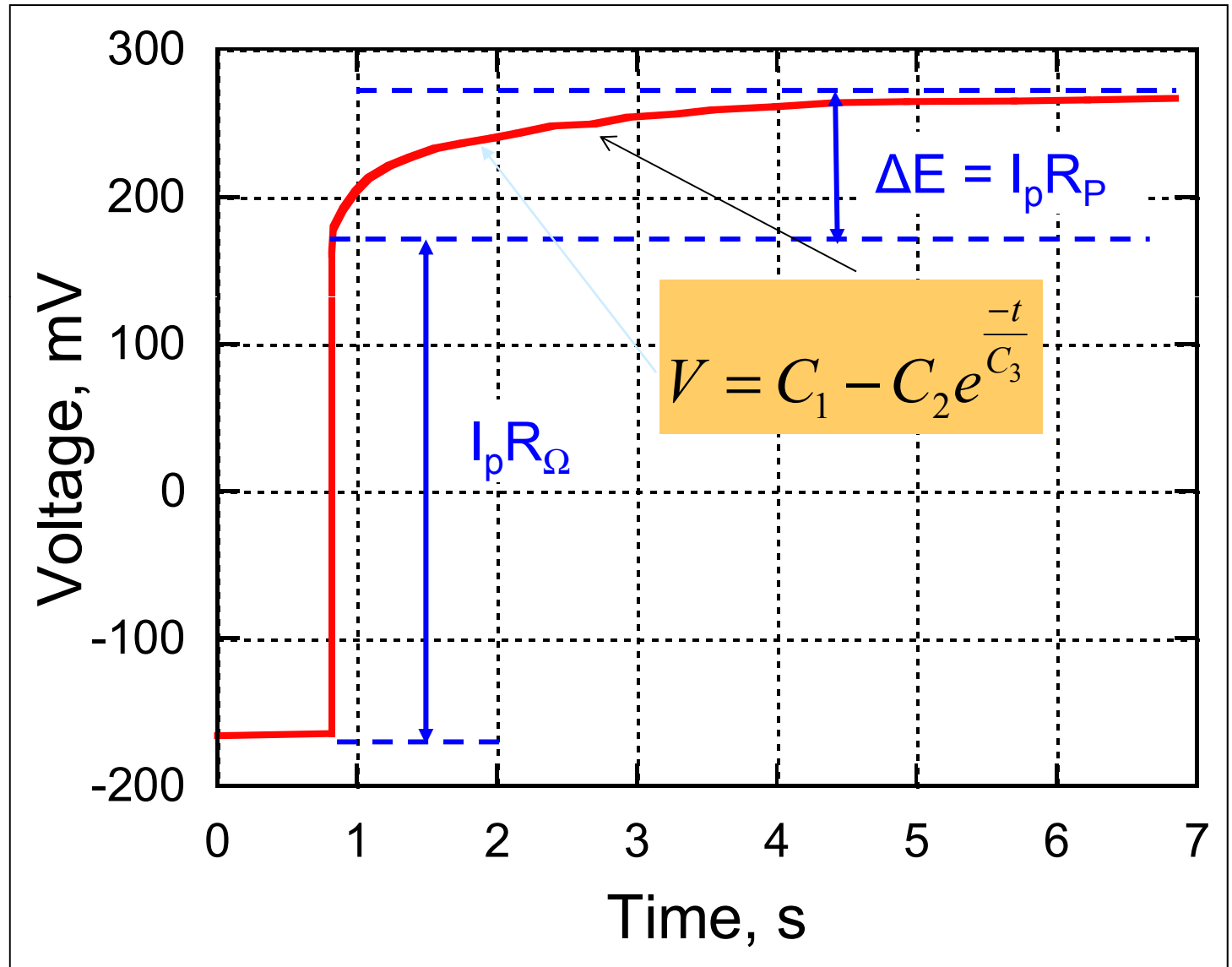



Instrumentation

- Several commercial instruments are based on the pulsed method
 - ◆ GalvaPulse
 - ◆ RapidCor
- Do not give the same readings, but will give same relative order of corrosion activity



GalvaPulse

- Based on galvanic-pulse method
- Integrates into one unit:
 - ◆ Half-cell potential
 - ◆ Resistance (not resistivity)
 - ◆ Polarization resistance
- Software for data analysis and 3-D displays

GalvaPulse

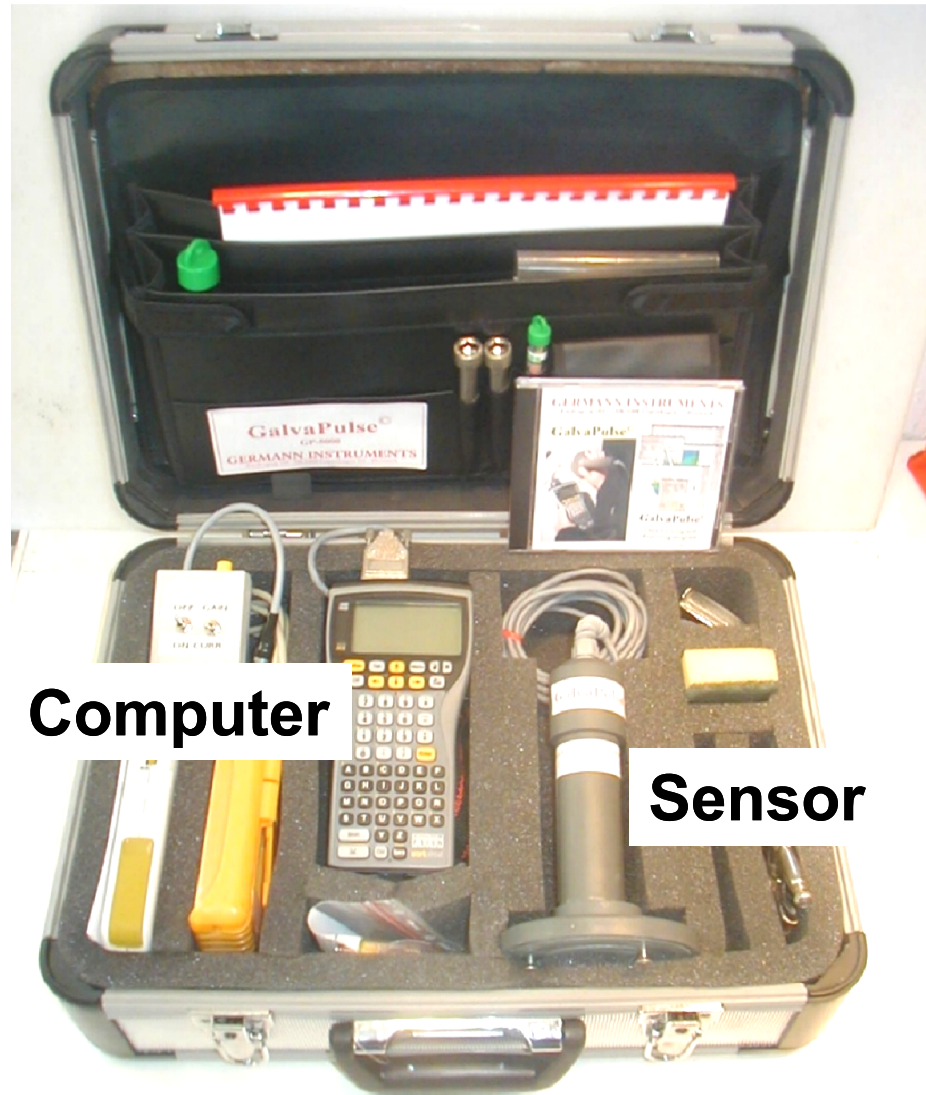

Computer

Sensor



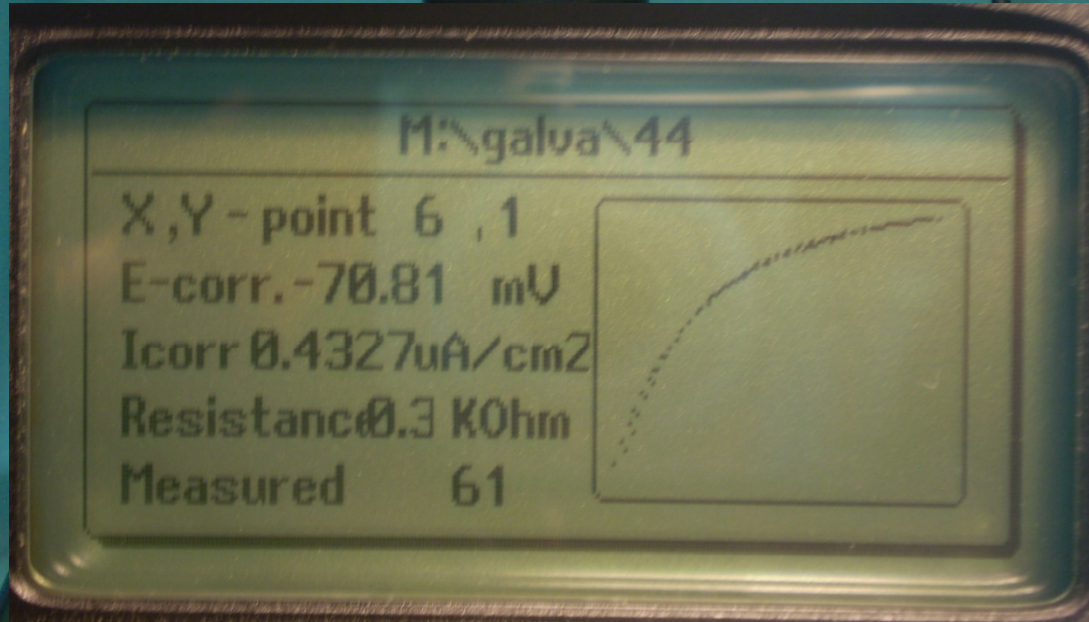

$i_{corr} = 0.43 \mu\text{A}/\text{cm}^2$
or 0.005 mm/year

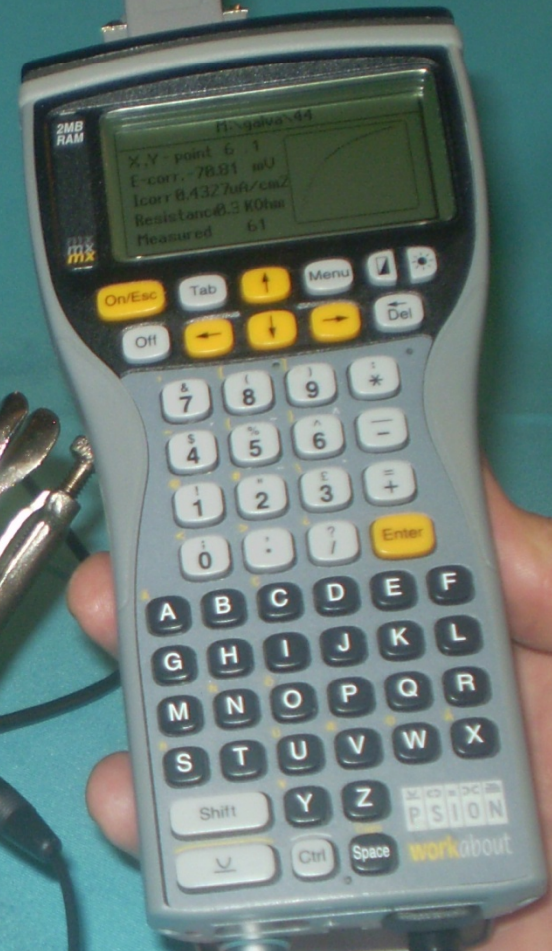

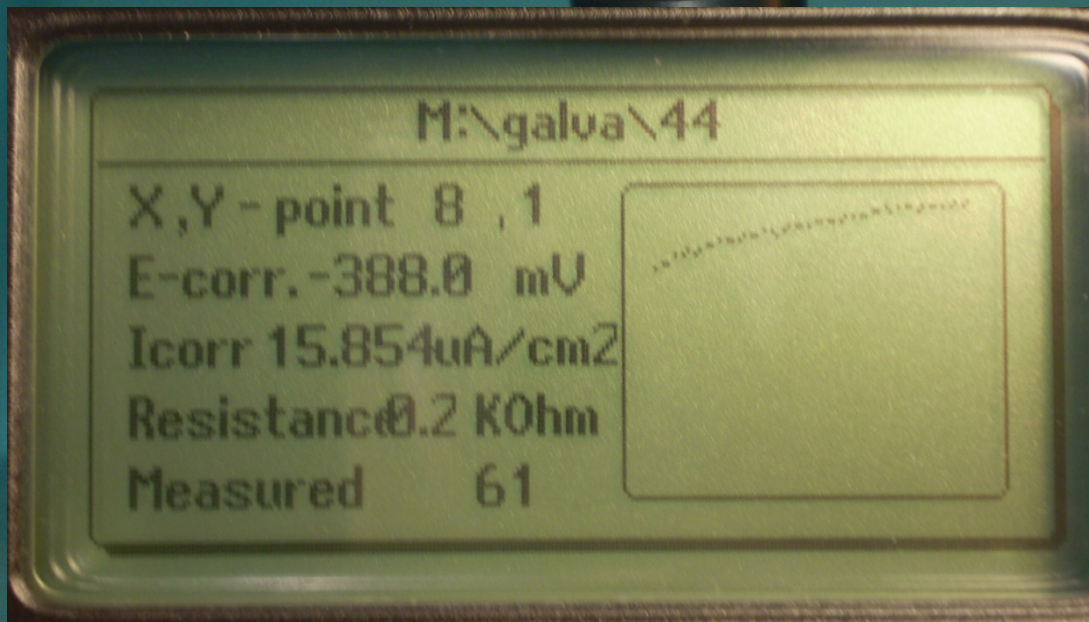

$i_{corr} = 15.9 \mu\text{A}/\text{cm}^2$
or 0.2 mm/year

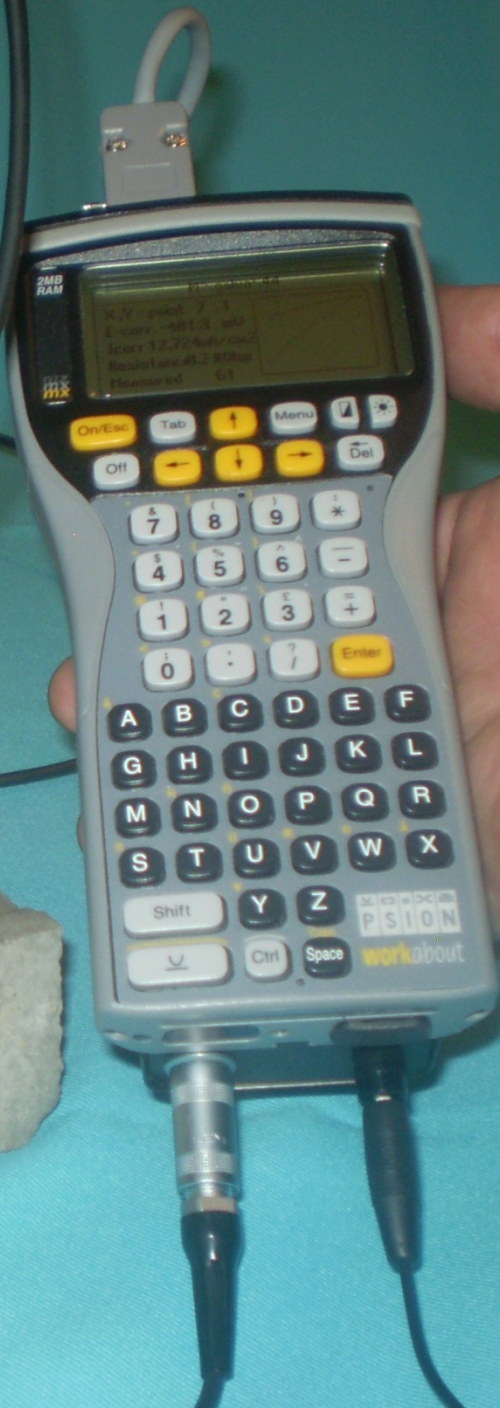



RapiCor

- Galvanic pulse method
- Rectangular probe with guard electrode
- Modulates polarization current based on corrosion activity
 - ◆ Higher current needed for higher corrosion rate
- Calculates concrete resistivity
 - ◆ Requires knowing cover thickness

RapiCor



Counter electrode

Reference electrode

Ag/AgCl

Guard electrode

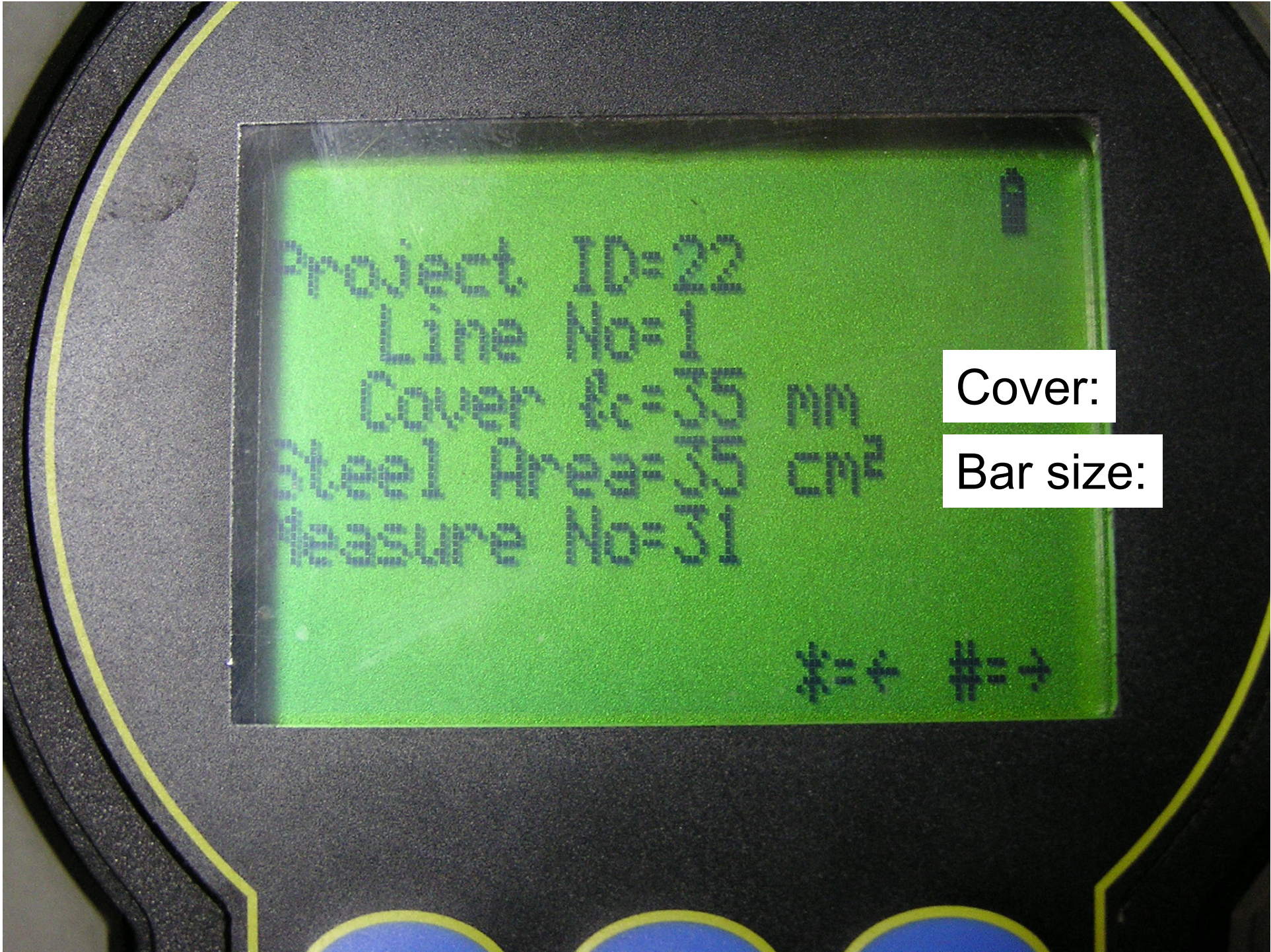

Cover:

Bar size:

Thickness loss:

Half-cell potential:

Resistivity:

Xcorr =
0.1 μm/yr
Ucorr =
-34 mV
R =
52 KΩcm
= 4



Summary

- Introduction to tools for in-place evaluation of concrete and steel reinforcement
 - ◆ Uniformity
 - ◆ Strength
 - ◆ Internal defects
 - ◆ Corrosion assessment
- Principles of methods have been stressed
- Not a training course on proper use of instruments



Tests for Uniformity

- Locate anomalous areas for closer examination
- Rebound hammer
 - ◆ Indicator of surface condition
 - ◆ Affected by texture, moisture content, carbonation
- Pulse velocity
 - ◆ Overall condition of concrete between transducers
 - ◆ Does not provide depth information



In-Place Strength

- Strength of drilled cores is reference method
- Pullout test
 - ◆ Sample more points without excessive damage
 - ◆ Good correlation with compressive strength
 - ◆ Evaluates outer 25 mm
- Pull-off test
 - ◆ Evaluate substrate preparation before repair
 - ◆ Evaluate bond strength of repair
 - ◆ Failure location depends on weakest link



Internal Defects

- Stress wave methods are inherently powerful because of complete reflection at air interface
- Impact-echo method
 - ◆ Point method; simple data processing
- Impulse-response method
 - ◆ Measures flexural response; comparative
- Ultrasonic-echo
 - ◆ Computer intensive; rapid; 3-D imaging



Corrosion Assessment

- Half-cell potential
 - ◆ Likelihood of active corrosion
- Polarization resistance
 - ◆ Indicator of corrosion rate at time of testing
 - ◆ Assumptions made to arrive at corrosion current density



Training

- Different levels of expertise are required
 - ◆ Rebound hammer → impact-echo
- Training is essential for proper use of these methods
 - ◆ No national programs
 - ◆ Manufacturers and “on the job”
- Flaw detection methods require experience for proper interpretation
 - ◆ Verification with invasive probing
- Corrosion assessment requires a corrosion expert

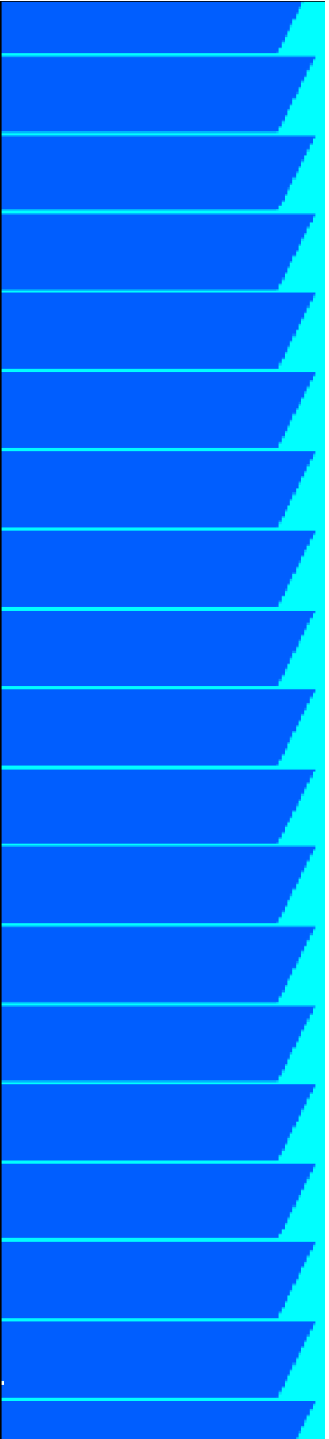

?