



Entergy Nuclear Operations, Inc.
Palisades Nuclear Plant
27780 Blue Star Memorial Highway
Covert, MI 49043
Tel 269 764 2000

Terry A. Davis
Regulatory Assurance Manager

PNP 2014-044

April 30, 2014

10 CFR 50.36a

U. S. Nuclear Regulatory Commission
ATTN: Document Control Desk
Washington, DC 20555-0001

Subject: 2013 Annual Radioactive Effluent Release and Waste Disposal Report

Palisades Nuclear Plant
Docket 50-255
License No. DPR-20

Big Rock Point
Dockets 50-155 and 72-043
License No. DPR-6

Dear Sir or Madam:

Attached are the Entergy Nuclear Operations, Inc. 2013 Annual Radioactive Effluent Release and Waste Disposal Reports for Palisades Nuclear Plant (PNP) and Big Rock Point (BRP) Independent Spent Fuel Storage Installation (ISFSI). These reports are submitted in accordance with 10 CFR 50.36a(a)(2).

Attachment 1 contains the report for PNP. Attachment 2 contains the report for the BRP ISFSI.

These reports provide a summary of the quantities of radioactive liquid and gaseous effluent releases and solid radioactive waste processed during the period of January 1, 2013, through December 31, 2013.

TE48
NM5526

This letter contains no new commitments and no revision to existing commitments.

Sincerely,

A handwritten signature in black ink, appearing to read 'TAD/bed', with a large, stylized initial 'T' and a long horizontal stroke.

TAD/bed

Attachment 1: Palisades Nuclear Plant 2013 Radioactive Effluent Release Report
Attachment 2: Big Rock Point Independent Spent Fuel Storage Installation 2013
Radioactive Effluent Release Report

CC Administrator, Region III, USNRC
Project Manager, Palisades, USNRC (w/o Attachments)
Resident Inspector, Palisades, USNRC
NRC NMSS Project Manager, USNRC (w/o Attachments)
American Nuclear Insurers (ANI)

Attachment 1
Palisades Nuclear Plant 2013 Radioactive Effluent Release Report

2013 Plant Operating History

Palisades Nuclear Plant (PNP) entered the reporting period on line on January 1, 2013, at nominal full power. PNP performed a planned shutdown on February 15, 2013, to address a leak in the component cooling water (CCW) heat exchanger and to repair the main generator motor operated disconnect, 26H5. The unit attained criticality on February 21, 2013, and returned to service on February 22, 2013. PNP performed a controlled shutdown on May 5, 2013, due to exceeding allowable leakage of the safety injection refueling water tank (T-58). The unit attained criticality on June 16, 2013, and returned to service on June 17, 2013. PNP was on line for the remainder of 2013. The unit generated 6,041,696 MWHrs of net electrical energy during 2013.

A. Gaseous Effluents

Tables 1A, "Gaseous Effluents – Summation of All Discharges," 1B, "Gaseous Effluents – Ground-Level Release – Batch Mode," and 1C, "Gaseous Effluents – Ground-Level Release – Continuous Mode," list and summarize gaseous effluents released during this reporting period.

B. Liquid Effluents

Tables 2A, "Liquid Effluents – Summation of All Discharges," 2B, "Liquid Effluents – Batch Mode," and 2C, "Liquid Effluents – Continuous Mode," list and summarize liquid effluents released during this reporting period.

C. Solid Waste Storage and Shipments

Table 3, "Low-Level Waste," summarizes solid radioactive waste shipped for processing or burial in 2013 for the following waste streams: resins, filters and evaporator bottoms, dry active waste, irradiated components and other waste.

D. Dose Assessments

Table 4, "Dose Assessments, 10 CFR Part 50, Appendix I," and Table 5, "EPA 40 CFR Part 190, Individual in the Unrestricted Area," list annual dose to the members of the public.

E. Supplemental Information

1. **Regulatory Limits**

a. Noble Gases

The air dose in unrestricted areas due to noble gas released in gaseous effluents shall be limited to the following:

- During the calendar quarter, to ≤ 5 mrad for gamma radiation and ≤ 10 mrad for beta radiation.
- During the calendar year, to ≤ 10 mrad gamma radiation and ≤ 20 mrad for beta radiation.

b. Iodines – Particulates

The dose to a member of the public from radioiodines, radioactive material in particulate form with half-lives greater than eight days, and radionuclides other than noble gas, e.g., tritium, in gaseous effluents released to unrestricted areas shall be limited to the following:

- During any calendar quarter, to ≤ 7.5 mrem to any organ
- During any calendar year, to ≤ 15 mrem to any organ

c. Liquid Effluents

The dose or dose commitment to an individual from radioactive material in liquid effluents released to unrestricted areas shall be limited to the following:

- During any calendar quarter to ≤ 1.5 mrem to the total body and ≤ 5 mrem to any organ.
- During any calendar quarter to ≤ 3 mrem to the total body and ≤ 10 mrem to any organ.

d. Total Dose

The dose or dose commitment to a real individual from all uranium fuel cycle sources is limited to ≤ 25 mrem to the total body or any organ (except the thyroid, which is limited to ≤ 75 mrem) over a period of 12 consecutive months.

2. Maximum Permissible Concentrations (Effluent Concentration Limits)

a. Gaseous Effluents

The dose rate due to radioactive material released in gaseous effluents from the site shall be limited to the following:

- For noble gases: ≤ 500 mrem/yr to the total body and ≤ 3000 mrem/yr to the skin.
- For all radioiodines and for all radioactive materials in particulate form with half-lives greater than eight days and for radionuclides other than noble gases: ≤ 1500 mrem/yr to any organ.

The above limits are provided to ensure that radioactive material discharged in gaseous effluents will not result in the exposure of an individual in an unrestricted area to annual average concentrations exceeding the limits of 10 CFR 20, Appendix B, Table 2, Column 1.

b. Liquid Effluents

The concentration of radioactive material released at any time from the site to unrestricted areas shall be limited to the concentrations specified in 10CFR20, Appendix B, Table 2, Column 2, for radionuclides other than dissolved or entrained noble gases. For dissolved or entrained noble gases, the concentration shall be limited to $2E-4$ $\mu\text{Ci/ml}$ total activity.

3. Average Energy

The average energy (\bar{E}) of the radionuclide mixture in releases of fission and activation gases as defined in Regulatory Guide 1.21, Appendix B, Section A.3 is not applicable because the limits used for gaseous releases are based on calculated dose to members of the public.

4. Measurements and Approximations of Total Radioactivity

- a. Fission and activation gases are sampled and then analyzed on a 4096 channel analyzer with a high purity germanium (HpGe) detector.
- b. Iodines are sampled and then analyzed on a 4096 channel analyzer with a HpGe detector.

- c. Particulates are sampled and then analyzed on a 4096 channel analyzer with a HpGe detector.
- d. Liquid effluents are sampled and then analyzed on a 4096 channel analyzer with a HpGe detector. Tritium analysis is performed using liquid scintillation. Fe-55, Sr-89, and Sr-90 analyses are performed by an offsite vendor. The vendor also analyzes for Ni-63 due to the evaluation of 10 CFR 61 sample results.

5. Batch Releases – 2013

For PNP, these totals are not indicative of actual release volumes due to PNP having two sets of tanks with different volumes in both the gaseous and liquid release systems that are utilized for batch releases. The number of batches performed in this section will fluctuate from year to year due to the utilization of the smaller and larger tanks in different frequencies. This information is better quantified in the tables contained later in this report.

a. Liquid

Number of batch releases for each quarter: 2 in the 1st quarter
 5 in the 2nd quarter
 2 in the 3rd quarter
 4 in the 4th quarter

Total time period for batch releases: 9859 minutes

Maximum time period for a batch release: 1458 minutes

Average time period for a batch release: 758 minutes

Minimum time period for a batch release: 70 minutes

Average stream flow during periods of release of effluent into a flowing stream: 64615 gpm

b. Gaseous

Number of batch releases for each quarter: 6 in the 1st quarter
 9 in the 2nd quarter
 4 in the 3rd quarter
 2 in the 4th quarter

Total time period for batch releases: 5883 minutes
 Maximum time period for a batch release: 1111 minutes
 Average time period for a batch release: 280 minutes
 Minimum time period for a batch release: 53 minutes

6. Abnormal Discharges

a. Liquid

Number of releases for each quarter			
1st Quarter	2nd Quarter	3rd Quarter	4th Quarter
<u>0</u>	<u>1 *</u>	<u>1 *</u>	<u>0</u>
Total activity released in Curies (Ci)			
1st Quarter	2nd Quarter	3rd Quarter	4th Quarter
<u>0</u>	<u>0.0166</u>	<u>0.844</u>	<u>0</u>

b. Gaseous

Number of releases for each quarter			
1st Quarter	2nd Quarter	3rd Quarter	4th Quarter
<u>0</u>	<u>0</u>	<u>0</u>	<u>0</u>
Total activity released in Curies (Ci)			
1st Quarter	2nd Quarter	3rd Quarter	4th Quarter
<u>0</u>	<u>0</u>	<u>0</u>	<u>0</u>

* - Discussions of these releases are in Section 14 - "Other"

7. Non-Routine Planned Discharges

None.

8. Radioactive Waste Treatment System Changes

None.

9. Annual Land Use Census Changes

The garden critical receptor has changed and is now located in the SSE sector at .69 miles. The residence critical receptor is unchanged in the SSE sector at 0.8 miles. The goats remain located to the ENE at 2.62 miles and are fed stored feed. During the 2013 land use census, it was identified that a new beef cattle receptor is located in the SE sector at 4.27 miles. There are no dairy cows located within five miles of the plant.

10. Effluent Monitoring System Inoperability

There were three effluent monitors that were out of service for greater than 30 days.

RIA-2320, steam generator blowdown vent monitor, was declared inoperable on November 6, 2012, due to indicating that it failed (CR-PLP-2012-7101). The pathway was not in service, but there was suspected valve leakage into the system so compensatory samples were being obtained as a conservative measure as if it were in service. The monitor was returned to service on April 15, 2013, under Work Order 333897.

RIA-2325, stack iodine/particulate monitor, was declared inoperable on August 13, 2013, due to failing to bring in the high alarm during performance of QR-22, "Process Monitor Function Checks – Quarterly" (CR-PLP-2013-3526). Compensatory sampling was initiated per DWR-10, "Stack Effluent Sampling and Calculation," and the Offsite Dose Calculation Manual (ODCM), and continued until RIA-2325 was returned to service. The monitor was returned to service on October 22, 2013, under Work Order 361036.

RIA-0631, condenser offgas monitor, was declared inoperable on November 5, 2013, due to failing to respond to a source check during performance of MR-14, "Process Monitor Function Checks – Monthly" (CR-PLP-2013-4778). Compensatory sampling was initiated per the ODCM. Troubleshooting remained in progress through the end of the year.

11. Offsite Dose Calculation Manual Changes

There was no revision to the ODCM during the report period.

12. Process Control Program Changes

None.

13. Errata/Corrections to Previous Reports

Supplemental Information section on Batch Release totals has been missing starting with the 2009 Annual Report. This page is a summation of total number of batch releases performed during the applicable year. For PNP, these totals are not indicative of actual release volumes due to PNP having two different sets of tanks with different volumes in both the gaseous and liquid release systems that are utilized for batch releases. The number of batches performed in this section will fluctuate from year to year due to the use of the smaller and larger tanks in different frequencies. This information is better quantified in the data tables contained in their respective reports.

This errata information was evaluated under CR-PLP-2013-2513, Corrective Action 7.

2009 Supplemental Information

Batch Releases

a. Liquid

Number of batch releases for each quarter: 10 in the 1st quarter
14 in the 2nd quarter
10 in the 3rd quarter
5 in the 4th quarter

Total time period for batch releases: 7787 minutes

Maximum time period for a batch release: 763 minutes

Average time period for a batch release: 211 minutes

Minimum time period for a batch release: 59 minutes

Average stream flow during periods of release of effluent into a flowing stream: 80000 gpm

b. Gaseous

Number of batch releases for each quarter: 14 in the 1st quarter
8 in the 2nd quarter
5 in the 3rd quarter
2 in the 4th quarter

Total time period for batch releases: 3244 minutes

Maximum time period for a batch release: 210 minutes

Average time period for a batch release: 112 minutes

Minimum time period for a batch release: 63 minutes

Abnormal Discharges

a. Liquid

Number of releases for each quarter

1st Quarter	2nd Quarter	3rd Quarter	4th Quarter
<u>0</u>	<u>0</u>	<u>0</u>	<u>0</u>

Total activity released in Curies (Ci)

1st Quarter	2nd Quarter	3rd Quarter	4th Quarter
<u>0</u>	<u>0</u>	<u>0</u>	<u>0</u>

b. Gaseous

Number of releases for each quarter

1st Quarter	2nd Quarter	3rd Quarter	4th Quarter
<u>0</u>	<u>0</u>	<u>0</u>	<u>0</u>

Total activity released in Curies (Ci)

1st Quarter	2nd Quarter	3rd Quarter	4th Quarter
<u>0</u>	<u>0</u>	<u>0</u>	<u>0</u>

2010 Supplemental Information

Batch Releases

a. Liquid

Number of batch releases for each quarter: 5 in the 1st quarter
3 in the 2nd quarter
11 in the 3rd quarter
6 in the 4th quarter

Total time period for batch releases: 14411 minutes

Maximum time period for a batch release: 1544 minutes

Average time period for a batch release: 576 minutes

Minimum time period for a batch release: 70 minutes

Average stream flow during periods of release of effluent into a flowing stream: 75520 gpm

b. Gaseous

Number of batch releases for each quarter: 4 in the 1st quarter
5 in the 2nd quarter
9 in the 3rd quarter
11 in the 4th quarter

Total time period for batch releases: 3431 minutes

Maximum time period for a batch release: 239 minutes

Average time period for a batch release: 118 minutes

Minimum time period for a batch release: 56 minutes

Abnormal Discharges

a. Liquid

Number of releases for each quarter

1st Quarter	2nd Quarter	3rd Quarter	4th Quarter
<u>0</u>	<u>0</u>	<u>0</u>	<u>0</u>

Total activity released in Curies (Ci)

1st Quarter	2nd Quarter	3rd Quarter	4th Quarter
<u>0</u>	<u>0</u>	<u>0</u>	<u>0</u>

b. Gaseous

Number of releases for each quarter

1st Quarter	2nd Quarter	3rd Quarter	4th Quarter
<u>0</u>	<u>0</u>	<u>0</u>	<u>0</u>

Total activity released in Curies (Ci)

1st Quarter	2nd Quarter	3rd Quarter	4th Quarter
<u>0</u>	<u>0</u>	<u>0</u>	<u>0</u>

2011 Supplemental Information

Batch Releases

a. Liquid

Number of batch releases for each quarter: 2 in the 1st quarter
3 in the 2nd quarter
4 in the 3rd quarter
6 in the 4th quarter

Total time period for batch releases: 12223 minutes

Maximum time period for a batch release: 1655 minutes

Average time period for a batch release: 815 minutes

Minimum time period for a batch release: 74 minutes

Average stream flow during periods of release of effluent into a flowing stream: 66667 gpm

b. Gaseous

Number of batch releases for each quarter: 7 in the 1st quarter
9 in the 2nd quarter
12 in the 3rd quarter
3 in the 4th quarter

Total time period for batch releases: 7491 minutes

Maximum time period for a batch release: 1314 minutes

Average time period for a batch release: 242 minutes

Minimum time period for a batch release: 53 minutes

Abnormal Discharges

a. Liquid

Number of releases for each quarter

1st Quarter	2nd Quarter	3rd Quarter	4th Quarter
<u>0</u>	<u>1</u>	<u>0</u>	<u>0</u>

Total activity released in Curies (Ci)

1st Quarter	2nd Quarter	3rd Quarter	4th Quarter
<u>0</u>	<u>3.66</u>	<u>0</u>	<u>0</u>

b. Gaseous

Number of releases for each quarter

1st Quarter	2nd Quarter	3rd Quarter	4th Quarter
<u>0</u>	<u>0</u>	<u>0</u>	<u>0</u>

Total activity released in Curies (Ci)

1st Quarter	2nd Quarter	3rd Quarter	4th Quarter
<u>0</u>	<u>0</u>	<u>0</u>	<u>0</u>

2012 Supplemental Information

Batch Releases

a. Liquid

Number of batch releases for each quarter: 8 in the 1st quarter
12 in the 2nd quarter
2 in the 3rd quarter
4 in the 4th quarter

Total time period for batch releases: 26279 minutes

Maximum time period for a batch release: 2700 minutes

Average time period for a batch release: 1011 minutes

Minimum time period for a batch release: 81 minutes

Average stream flow during periods of release of effluent into a flowing stream: 39996 gpm

b. Gaseous

Number of batch releases for each quarter: 6 in the 1st quarter
15 in the 2nd quarter
9 in the 3rd quarter
4 in the 4th quarter

Total time period for batch releases: 4201 minutes

Maximum time period for a batch release: 290 minutes

Average time period for a batch release: 124 minutes

Minimum time period for a batch release: 59 minutes

Abnormal Discharges

a. Liquid

Number of releases for each quarter			
1st Quarter	2nd Quarter	3rd Quarter	4th Quarter
<u>0</u>	<u>0</u>	<u>0</u>	<u>0</u>

Total activity released in Curies (Ci)			
1st Quarter	2nd Quarter	3rd Quarter	4th Quarter
<u>0</u>	<u>0</u>	<u>0</u>	<u>0</u>

b. Gaseous

Number of releases for each quarter			
1st Quarter	2nd Quarter	3rd Quarter	4th Quarter
<u>0</u>	<u>0</u>	<u>0</u>	<u>0</u>

Total activity released in Curies (Ci)			
1st Quarter	2nd Quarter	3rd Quarter	4th Quarter
<u>0</u>	<u>0</u>	<u>0</u>	<u>0</u>

14. Other

Groundwater Monitoring

PNP has 14 ground water monitoring wells (MW) strategically placed within the owner controlled area, to allow for detection of radioactive contamination of ground water due to leaks or spills from plant systems. PNP added 18 temporary wells (TW) in 2009, to determine the potential source of tritium in groundwater in the vicinity of MW-3. Tanks T-90, primary makeup tank, T-91, utility water storage tank, and associated underground piping between these tanks and the auxiliary building addition, are in this area.

Underground piping repairs to the T-90/T-91 overflow piping were completed in 2013 following sleeving of the second half of the underground piping to ensure system integrity. The first half of the piping was sleeved in 2011. During the process of repairing the piping in September 2013, a small amount of tritiated liquid was discharged from the pipe to the environment. Indications of this discharged liquid were evident in the November and December 2013 samples of TW-15 (peak on December 5, 2013, at 166,165 pci/L). TW-9, located nearest the site boundary and down-gradient of TW-15 showed a slight increase (December, 5, 2013, at 2,151 pci/L from < minimum detectable activity (MDA) on November 6, 2013) in tritium, due to this discharged liquid.

Tritium levels for 2013 in MW-3 remained less than MDA, which is down from 5,233 pCi/L in March 2012. The highest value in MW-2 was 702 pCi/L in May 2013. MW-11 exhibited five detectable readings in 2013, with the highest being 1,436 pCi/L in September 2013. Values of this magnitude may be attributed to precipitation recapture of tritium, as indicated in the PNP precipitation recapture study performed in 2011. The remaining monitoring wells showed no activity throughout the year. No radionuclides other than tritium have been detected in the groundwater.

Temporary well monitoring in 2013 indicated a possible continued leak from the T-90/91 overflow piping to the surrounding environment early in the year. This was documented in CR-PLP-2013-00304, and was repaired in the summer of 2013, by the additional sleeving of T-90/T-91 overflow piping. Tritium monitoring indicated positive results from the suspected piping leak site with a slow declining trend in the direction of underground hydrological flow. MW-3 and TW-9 are directly down-gradient from the elevated TW's. MW-3 showed no elevated tritium results in 2013, and TW-9 showed only a slight increase in tritium values associated with the repair operations.

The tritiated water discharged in 2011 and 2013 from repair activities to the T-90/T-91 overflow piping, were considered part of the same leak event first reported to the NRC in 2007, therefore, no additional reports were made for these leaks. After the leaks were repaired and reporting time had elapsed, the NRC questioned whether these events could have warranted additional reporting, due to the cause and effect nature associated with repair activities, even though they originated from the same leak location.

Monitoring of the groundwater tritium plume continues to assess repair effectiveness and follow the site hydrology data. Well locations are depicted in Figure 1.

Depth to Local Water Table – The depth is approximately eight to nine feet.

Classification of Subsurface Aquifers – Not used for drinking water.

Expected Movement/Mobility of Groundwater Plume – Westerly direction down-gradient toward Lake Michigan at approximately two feet per day.

Land Use Characteristics – PNP site property, water not used for drinking or irrigation.

NRC Notification, Date and contact Organization – The NRC was notified on December 10, 2007, by PNP.

Carbon-14

In 2010, PNP and other facilities participated in an EPRI task force to build a model to accurately estimate gaseous C-14 releases, given some key site-specific plant parameters (mass of the primary coolant, average thermal neutron cross section, rated MW, etc). This work was completed in November 2010. The estimates for C-14 were constructed using the aforementioned EPRI methodology contained with EPRI 1021106, "Estimation of Carbon-14 in Nuclear Power Plant Gaseous Effluents." Using the C-14 curie estimates, the annual dose to man was derived from guidance contained within Regulatory Guide 1.109. Because the dose contribution of C-14 from liquid radioactive waste is much less than that contributed by gaseous radioactive waste, evaluation of C-14 in liquid radioactive waste is not required.

Annual C-14 release PNP and subsequent doses for 2013:

Total Gaseous C-14 Released Curies =	7.43
Gaseous C-14 as CO2 Curies =	2.23
Effective Child TB Dose, C-14 mrem =	0.0345
Effective Child Bone Dose, C-14 mrem =	0.173

The quarterly curies released are provided in Table A-1B. Airborne doses due to C-14 are grouped under the category of Particulate, Iodine, and Tritium which are contained in Table A-4.

Safety Injection Refueling Water (SIRW) Tank

A plant shutdown was initiated on May 5, 2013, at 0127 hours, due to safety injection and refueling water (SIRW) tank leakage. With the increased leakage from the tank into the surrounding roofing material, "water bladders" had formed under the roofing material and were being monitored and routinely drained. Leak rate had increased to the point of potential water bladder rupture/overflow and allowed leakage onto the roof and into the roof drain system. SIRW tank leakage migrated primarily to the south roof drain, which is part of storm water drain system SW-2, with some small amount traveling to the west roof drain, which is part of storm water drain system SW-6.

NOTE: The east and west roof drains run to a common line which drains into a separate storm water drain system (SW-6) that discharges into the mixing basin, a monitored release path via RIA-1323, circulating water discharge radiation monitor, and was diluted by 40,000 gpm flow from the dilution water pumps P-40A/B.

On May 6, 2013, radioactive water was identified in storm water drain system, SW-2, located on the south side of the plant (CR-PLP-2013-2084). Radioactivity levels identified: Gamma Emitters: 1.49E-5 uCi/ml and Tritium: 4.27E-2 uCi/ml. This activity aligns with activity from samples collected from the SIRW roof south drain. The leakage into the south roof drain flowed (open pipe) onto the component cooling water (CCW) roof, where the water then ran down the CCW roof drain, which drains to the south storm water drain system (SW-2). Via field observation, it was determined that the outlet of this south storm water drain system constituted a potential unmonitored, undiluted pathway; however, the outlet of this storm water drain system was found completely plugged with sand and debris prior to reaching the beach.

Actions Taken:

- Water bladders were drained into the radiological controlled area (RCA) via an established collection/drainage system.

- Standing water was removed from the SIRW tank roof and the roof was decontaminated.
- SW-2 storm water drain lines were vacuumed out into radioactive material labeled drums.
- A bladder was installed into the storm water drain line prior to the last manhole.
- The CCW roof drain was flushed with clean water to storm water drain system SW-2.
- SW-2 flush water was sampled and pumped to the mixing basin for monitored release.
- Flushing of SW-2 was performed until below ODCM levels. Most sample points were less than minimum detectable.
- East and west roof drains were also flushed through to the mixing basin and monitored via the normal plant process (normal REMP sampling and monitoring).

On May 29, 2013, following a rain storm, the sand/debris plug separating the storm water drain system (SW-2) from the beach was dislodged. One sample of the beach within the immediate vicinity of the discharge identified tritium and additional isotopes just above the lower limit of detection, but below ODCM reporting requirements. The following day, split samples were obtained with the NRC at four different locations on the beach between the discharge and the lake. All sample results analyzed by PNP were non-detectable, with the exception of the sample closest to the storm water system drain outlet, which had low levels of Sb-125. This was validated with the NRC split sample.

Surveys were performed on the SW-2 outfall piping during September 2013. 10 CFR 50.75(g) paperwork is being processed to document the beach sediment contamination for decommissioning work.

A dose calculation was performed and determined that if the entire quantity of the leak, that was conservatively calculated (81.2 gallons), would have flowed to the SW-2 storm water drain system, and subsequently made it to Lake Michigan, then the dose to the public would be less than 0.1% of the federal limits. It is known that not all of the leakage made it to the lake since volume was removed from the SW-2 storm water drain system. The outlet of the SW-2 drain had been completely covered with sand/debris. The site cleaned the storm water system prior to the May 29, 2013, rain storm. There was no evidence that any liquid ever left the protected area boundary via an unmonitored release path prior to May 29, 2013. This makes the dose calculation very conservative. The Storm Water System is depicted in Figure 2.

FIGURE 1 GROUNDWATER MONITORING WELL LOCATIONS

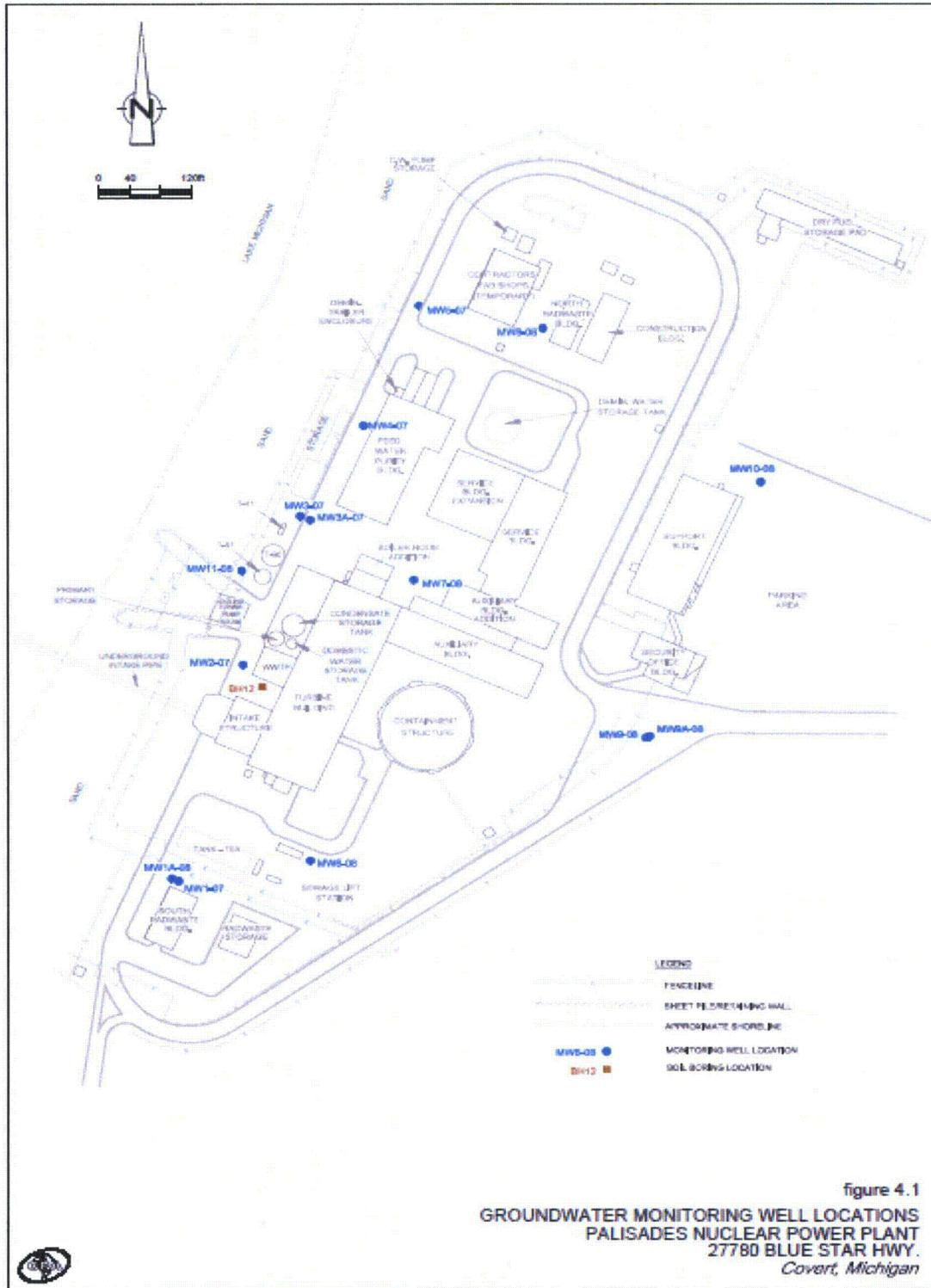

050625-03/02/GM-DE003 DEC 03/006

**FIGURE 2
DIAGRAM OF THE STORM WATER SYSTEM**

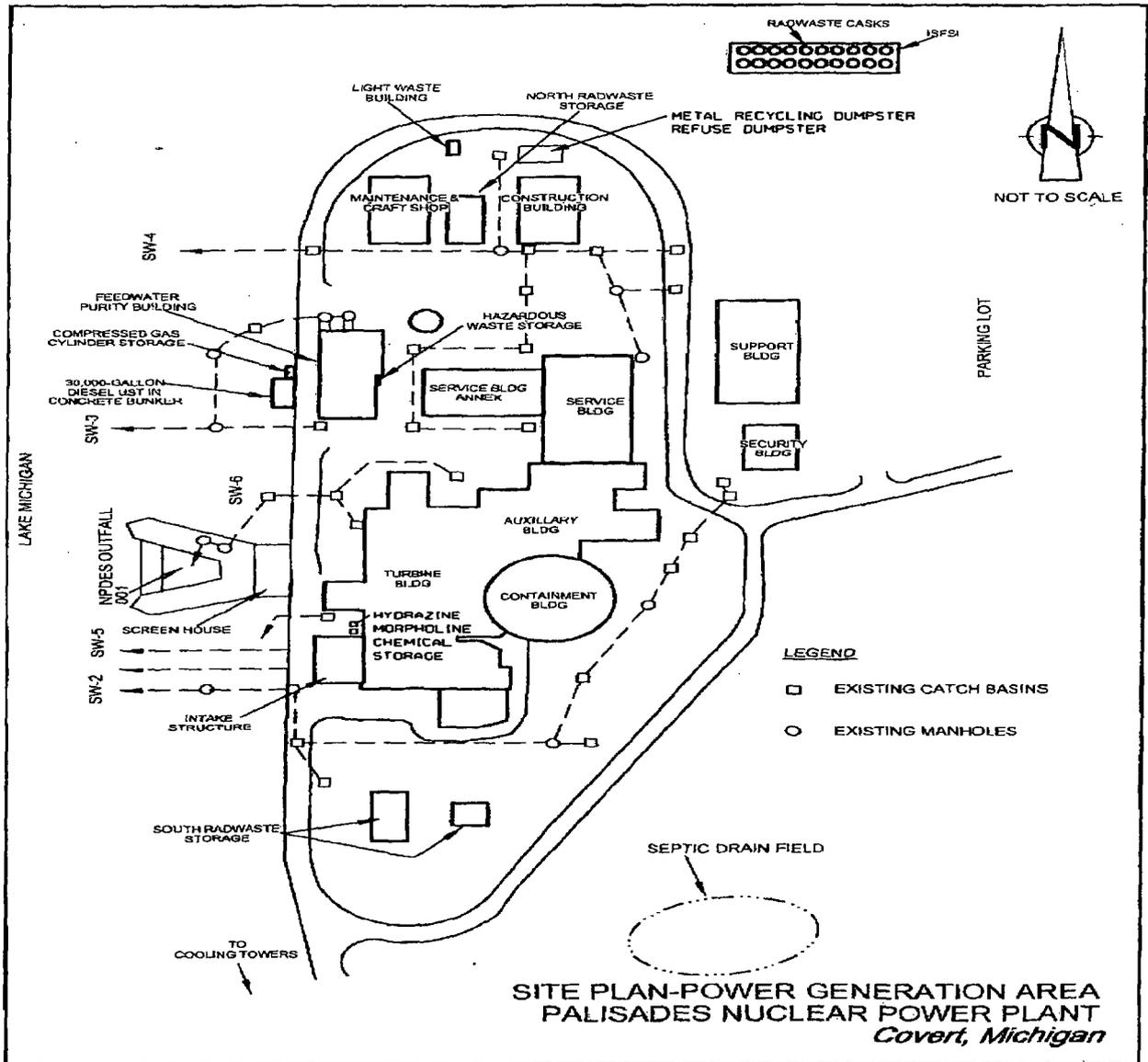

ATTACHMENT 1
Palisades - Table 1A
2013 Gaseous Effluents – Sum of All Releases

Summation of All Releases	Units	Quarter 1	Quarter 2	Quarter 3	Quarter 4	Total	Uncertainty (%)
Fission and Activation Gases	Ci	1.94E+00	4.01E-01	2.18E-02	6.50E-01	3.01E+00	4.47
Average Release Rate	μCi/s	2.49E-01	5.06E-02	2.52E-03	7.34E-02	9.54E-02	
% of Limit	%	1.14E-03	2.66E-04	3.12E-05	1.02E-03	6.12E-04	
Total I-131	Ci	6.28E-05	2.34E-05	4.95E-05	5.60E-05	1.92E-04	36.62
Average Release Rate	μCi/s	8.07E-06	2.98E-06	6.23E-06	7.05E-06	6.08E-06	
% of Limit	%	9.73E-08	3.59E-08	7.51E-08	8.49E-08	7.33E-08	
Particulates	Ci	0.00E+00	0.00E+00	0.00E+00	6.78E-08	6.78E-08	31.5
Average Release Rate	μCi/s	0.00E+00	0.00E+00	0.00E+00	4.22E-09	2.15E-09	
% of Limit	%	0.00E+00	0.00E+00	0.00E+00	2.04E-08	5.13E-09	
Tritium	Ci	3.26E+00	2.16E+00	1.21E+00	1.55E+00	8.19E+00	4.42
Average Release Rate	μCi/s	4.19E-01	2.75E-01	1.52E-01	1.96E-01	2.60E-01	
% of Limit	%	1.01E-03	6.63E-04	3.66E-04	4.71E-04	6.26E-04	
Gross Alpha	Ci	1.02E-06	ND	ND	ND	1.02E-06	14.9
C-14	Ci	1.98E+00	1.12E+00	2.17E+00	2.17E+00	7.44E+00	
Average Release Rate	μCi/s	2.55E-01	1.42E-01	2.73E-01	2.73E-01	2.36E-01	
% of Limit	%	2.05E-06	1.14E-06	2.19E-06	2.19E-06	1.90E-06	

ATTACHMENT 1
Palisades - Table 1B
2013 Gaseous Effluents – Ground Level Release, Batch Mode

Fission and Activation Gases	Units	Quarter 1	Quarter 2	Quarter 3	Quarter 4
Ar-41	Ci	ND	ND	ND	ND
Kr-85	Ci	ND	ND	ND	ND
Kr-85m	Ci	ND	ND	ND	ND
Kr-87	Ci	ND	ND	ND	ND
Kr-88	Ci	ND	ND	ND	ND
Xe-131m	Ci	7.69E-04	4.15E-03	ND	ND
Xe-133	Ci	1.20E+00	2.40E-01	2.58E-05	ND
Xe-133m	Ci	ND	1.34E-03	ND	ND
Xe-135	Ci	4.51E-02	3.42E-04	ND	ND
Xe-135m	Ci	ND	ND	ND	ND
Xe-138	Ci	ND	ND	ND	ND
Total	Ci	1.25E+00	2.46E-01	2.58E-05	0.00E+00

Iodines/Halogens	Units	Quarter 1	Quarter 2	Quarter 3	Quarter 4
I-131	Ci	1.99E-08	ND	ND	ND
I-132	Ci	ND	ND	ND	ND
I-133	Ci	ND	ND	ND	ND
I-134	Ci	ND	ND	ND	ND
I-135	Ci	ND	ND	ND	ND
Total	Ci	1.99E-08	0.00E+00	0.00E+00	0.00E+00

Particulates	Units	Quarter 1	Quarter 2	Quarter 3	Quarter 4
Co-58	Ci	ND	ND	ND	ND
Co-60	Ci	ND	ND	ND	ND
Na-24	Ci	ND	ND	ND	ND
Cr-51	Ci	ND	ND	ND	ND
Mn-56	Ci	ND	ND	ND	ND
Sr-92	Ci	ND	ND	ND	ND
Nb-95	Ci	ND	ND	ND	ND
Zr-95	Ci	ND	ND	ND	ND
Ag-110m	Ci	ND	ND	ND	ND
Total	Ci	0.00E+00	0.00E+00	0.00E+00	0.00E+00

Tritium	Ci	1.18E-01	1.12E-01	NA	NA
---------	----	----------	----------	----	----

Gross Alpha	Ci	5.109E-07	NA	NA	NA
-------------	----	-----------	----	----	----

C-14	Ci	NA	NA	NA	NA
------	----	----	----	----	----

ND = Measurements performed but no activity detected.

NA = Analysis not required and not performed

ATTACHMENT 1
Palisades - Table 1C
2013 Gaseous Effluents – Ground Level Release, Continuous Mode

Fission and Activation Gases	Units	Quarter 1	Quarter 2	Quarter 3	Quarter 4
Ar-41	Ci	1.19E-01	4.62E-02	5.39E-03	1.96E-01
Kr-85	Ci	ND	ND	ND	ND
Kr-85m	Ci	2.39E-02	2.52E-05	1.40E-04	8.28E-03
Kr-87	Ci	3.07E-03	5.71E-03	6.29E-04	2.93E-02
Kr-88	Ci	8.57E-02	7.59E-03	1.11E-03	2.61E-02
Xe-131m	Ci	ND	ND	ND	ND
Xe-133	Ci	1.79E-03	2.00E-02	8.57E-04	2.19E-02
Xe-133m	Ci	ND	ND	ND	ND
Xe-135	Ci	2.48E-01	2.54E-02	5.68E-03	1.18E-01
Xe-135m	Ci	7.70E-02	1.21E-02	2.42E-03	5.36E-02
Xe-137	Ci	2.39E-03	3.28E-03	1.80E-03	6.59E-02
Xe-138	Ci	1.26E-01	3.46E-02	3.79E-03	1.30E-01
Total	Ci	6.87E-01	1.55E-01	2.18E-02	6.50E-01

Iodines/Halogens	Units	Quarter 1	Quarter 2	Quarter 3	Quarter 4
I-131	Ci	6.27E-05	2.34E-05	4.95E-05	5.60E-05
I-132	Ci	ND	ND	ND	ND
I-133	Ci	4.49E-05	4.98E-05	7.86E-05	1.24E-04
I-135	Ci	ND	ND	ND	ND
Total	Ci	1.08E-04	7.32E-05	1.28E-04	1.80E-04

Particulates	Units	Quarter 1	Quarter 2	Quarter 3	Quarter 4
Co-58	Ci	ND	ND	ND	ND
Co-60	Ci	ND	ND	ND	3.36E-08
Mn-54	Ci	ND	ND	ND	ND
Cr-51	Ci	ND	ND	ND	ND
Co-57	Ci	ND	ND	ND	ND
Nb-95	Ci	ND	ND	ND	ND
Zr-95	Ci	ND	ND	ND	ND
Ag-110m	Ci	ND	ND	ND	ND
Sn-113	Ci	ND	ND	ND	ND
Sb-125	Ci	ND	ND	ND	ND
Cs-137	Ci	ND	ND	ND	3.43E-08
Ce-144	Ci	ND	ND	ND	ND
Total	Ci	0.00E+00	0.00E+00	0.00E+00	6.78E-08

Tritium	Ci	3.14E+00	2.05E+00	1.21E+00	1.55E+00
---------	----	----------	----------	----------	----------

Gross Alpha	Ci	5.11E-07	ND	ND	ND
-------------	----	----------	----	----	----

C-14	Ci	1.98E+00	1.12E+00	2.17E+00	2.17E+00
------	----	----------	----------	----------	----------

ND = Measurements performed but no activity detected.

ATTACHMENT 1
Palisades - Table 2A
2013 Liquid Effluents – Sum of All Releases

Summation of All Liquid Releases	Units	Quarter 1	Quarter 2	Quarter 3	Quarter 4	Total	Uncertainty (%)
Fission and Activation Products (excluding tritium, gases, and gross alpha)	Ci	4.47E-04	2.75E-03	1.47E-04	2.93E-03	6.27E-03	8.72
Average Concentration	µCi/ml	2.09E-11	8.90E-11	3.67E-12	7.50E-11	4.77E-11	
% of Limit	%	2.66E-04	1.62E-03	6.36E-05	1.17E-03	7.93E-04	
Tritium	Ci	1.25E+02	1.29E+02	6.21E+01	1.20E+02	4.36E+02	4.01
Average Concentration	µCi/ml	5.84E-06	4.18E-06	1.55E-06	3.06E-06	3.32E-06	
% of Limit	%	5.84E-01	4.18E-01	1.55E-01	3.06E-01	3.32E-01	
Dissolved and Entrained Gases	Ci	1.27E-04	0.00E+00	0.00E+00	3.32E-04	4.59E-04	13.20
Average Concentration	µCi/ml	5.95E-12	0.00E+00	0.00E+00	8.51E-12	3.49E-12	
% Of Limit	%	2.98E-06	0.00E+00	0.00E+00	4.26E-06	1.75E-06	
Gross Alpha	Ci	0.00E+00	0.00E+00	0.00E+00	0.00E+00	0.00E+00	0.00
Average Concentration	µCi/ml	0.00E+00	0.00E+00	0.00E+00	0.00E+00	0.00E+00	
Volume of Primary System Liquid Effluent (Before Dilution)	Liters	3.75E+05	6.28E+05	2.87E+05	5.79E+05	1.87E+06	
Dilution Water Used for Above	Liters	2.14E+10	3.10E+10	4.01E+10	3.90E+10	1.31E+11	
Volume of Secondary or Balance-of-Plant Liquid Effluent (e.g., low-activity or unprocessed) (Before Dilution)	Liters	8.06E+09	8.32E+09	8.27E+09	8.01E+09	3.27E+10	
Average Stream Flow	m ³ /s	2.75E+00	3.94E+00	5.05E+00	4.91E+00	4.16E+00	

Dilution flow rate (gal/qtr) = # of Dilution pumps running x days running/qtr x 4000 gpm/pump x min/day

ATTACHMENT 1
Palisades - Table 2B
2013 Liquid Effluents – Batch Mode

Fission and Activation Products	Units	Quarter 1	Quarter 2	Quarter 3	Quarter 4
Cr-51	Ci	ND	ND	ND	ND
Mn-54	Ci	ND	ND	ND	ND
Fe-55	Ci	2.10E-04	3.70E-04	4.22E-05	7.06E-04
Fe-59	Ci	ND	ND	ND	ND
Co-57	Ci	ND	ND	ND	ND
Co-58	Ci	ND	5.33E-04	9.53E-06	2.62E-04
Co-60	Ci	1.13E-04	1.20E-03	7.31E-05	1.06E-03
Sr-89	Ci	ND	ND	ND	ND
Sr-90	Ci	ND	ND	ND	ND
Nb-95	Ci	ND	ND	ND	ND
Ag-110m	Ci	9.97E-05	4.23E-04	ND	4.85E-04
Sn-113	Ci	ND	ND	ND	ND
Sb-124	Ci	ND	ND	ND	ND
Sb-125	Ci	ND	2.06E-05	ND	ND
I-131	Ci	ND	ND	ND	ND
I-133	Ci	ND	ND	ND	ND
I-135	Ci	ND	ND	ND	ND
Cs-134	Ci	ND	ND	ND	ND
Cs-137	Ci	ND	1.25E-06	ND	ND
Ni-63	Ci	2.43E-05	2.32E-04	2.25E-05	4.14E-04
Zn-65	Ci	ND	ND	ND	ND
Zr-95	Ci	ND	ND	ND	ND
La-140	Ci	ND	ND	ND	ND
Totals	Ci	4.47E-04	2.78E-03	1.47E-04	2.93E-03

Dissolved and Entrained Gases	Units	Quarter 1	Quarter 2	Quarter 3	Quarter 4
Kr-85	Ci	ND	ND	ND	ND
Xe-131m	Ci	ND	ND	ND	ND
Xe-133	Ci	1.27E-04	ND	ND	3.32E-04
Xe-133m	Ci	ND	ND	ND	ND
Xe-135	Ci	ND	ND	ND	ND
Totals		1.27E-04	0.00E+00	0.00E+00	3.32E-04

Tritium	Ci	1.25E+02	1.29E+02	6.20E+01	1.20E+02
---------	----	----------	----------	----------	----------

Gross Alpha	Ci	ND	ND	ND	ND

ND = None Detected

ATTACHMENT 1
Palisades - Table 2C
2013 Liquid Effluents – Continuous Mode

Fission and Activation Products	Units	Quarter 1	Quarter 2	Quarter 3	Quarter 4
Cr-51	Ci	ND	ND	ND	ND
Mn-54	Ci	ND	ND	ND	ND
Fe-55	Ci	ND	ND	ND	ND
Co-58	Ci	ND	ND	ND	ND
Co-60	Ci	ND	ND	ND	ND
Sr-89	Ci	ND	ND	ND	ND
Sr-90	Ci	ND	ND	ND	ND
Nb-95	Ci	ND	ND	ND	ND
Ag-110m	Ci	ND	ND	ND	ND
Sn-113	Ci	ND	ND	ND	ND
Sb-124	Ci	ND	ND	ND	ND
Sb-125	Ci	ND	ND	ND	ND
I-131	Ci	ND	ND	ND	ND
I-133	Ci	ND	ND	ND	ND
I-135	Ci	ND	ND	ND	ND
Cs-134	Ci	ND	ND	ND	ND
Cs-137	Ci	ND	ND	ND	ND
Ni-63	Ci	ND	ND	ND	ND
Totals	Ci	0.00E+00	0.00E+00	0.00E+00	0.00E+00

Dissolved and Entrained Gases	Units	Quarter 1	Quarter 2	Quarter 3	Quarter 4
Kr-85	Ci	ND	ND	ND	ND
Xe-133	Ci	ND	ND	ND	ND
Xe-133m	Ci	ND	ND	ND	ND
Xe-135	Ci	ND	ND	ND	ND
Xe-135m	Ci	ND	ND	ND	ND
Totals		0.00E+00	0.00E+00	0.00E+00	0.00E+00

Tritium	Ci	3.54E-02	1.44E-02	1.33E-02	1.26E-02
---------	----	----------	----------	----------	----------

Gross Alpha	Ci	ND	ND	ND	ND
-------------	----	----	----	----	----

ND = None Detected

**ATTACHMENT 1
Palisades - Table 3
2013 Low-Level Waste**

1. Solid waste shipped offsite for burial or disposal (not irradiated fuel)

1. Type of waste	Unit	Estimated amount	Est Total Error, %
a. Spent resin, filters, evaporator bottoms, etc.	m ³	1.66E+01	25
	Curies	7.26E+01	
b. Dry compressible waste, contaminated equipment, etc.	m ³	5.18E+02	25
	Curies	1.97E+00	
c. Irradiated components, control rods, etc.	m ³	0.00E+00	
	Curies	0.00E+00	
d. Other (describe) DAW / Metal Waste / Oil	m ³	2.84E+01	25
	Curies	1.67E-02	

2. Estimate of Major Nuclide composition (by type of waste), list nuclides as needed

a.	Co-60	38%	Mn-54	1%	Cs-134	9%
	Fe-55	3%	Co-58	2%		
	Cs-137	16%	Ag-110m	2%		
	Ni-63	26%	Sb-125	3%		
b.	Co-60	12%	Co-58	3%	Sb-125	6%
	Fe-55	35%	Ni-63	39%		
	Cs-137	2%	Nb-95	1%		
	Cr-51	1%	Ru-106	1%		
c.						
d.	H-3	1%	Co-58	36%	Ru-106	1%
	C-14	1%	Co-60	13%	Ag-110m	4%
	Cr-51	13%	Ni-63	7%	Sn-113	1%
	Mn-54	1%	Zr-95	5%	Sb-125	1%
	Fe-55	4%	Nb-95	10%	Cs-137	2%

**ATTACHMENT 1
Palisades - Table 3
2013 Low-Level Waste**

3. Solid waste disposition

Number of shipments	Mode of transportation	Destination
1	Truck	Kingston, Tn
19	Truck	Oakridge, Tn
2	Truck	Erwin, Tn

Irradiated fuel shipments (disposition)

Number of shipments	Mode of transportation	Destination
0		

**ATTACHMENT 1
Palisades - Table 4
2013 Dose Assessments, 10 CFR Part 50, Appendix I**

	Quarter 1	Quarter 2	Quarter 3	Quarter 4	Yearly
Liquid Effluent Dose Limit, Total Body	1.5 mrem	1.5 mrem	1.5 mrem	1.5 mrem	3 mrem
Total Body Dose	2.19E-04	3.15E-03	6.31E-05	5.24E-04	3.95E-03
% Of Limit	0.01%	0.21%	0.00%	0.03%	0.13%
Liquid Effluent Dose Limit, Any Organ	5 mrem	5 mrem	5 mrem	5 mrem	10 mrem
Organ Dose	2.22E-04	4.61E-03	6.39E-05	5.36E-04	5.44E-03
% of Limit	0.00%	0.09%	0.00%	0.01%	0.05%
Gaseous Effluent Dose Limit, Gamma Air	5 mrad	5 mrad	5 mrad	5 mrad	10 mrad
Gamma Air Dose	3.72E-04	8.30E-05	9.78E-06	3.15E-04	7.80E-04
% of Limit	0.01%	0.00%	0.00%	0.01%	0.01%
Gaseous Effluent Dose Limit, Beta Air	10 mrad	10 mrad	10 mrad	10 mrad	20 mrad
Beta Air Dose	2.59E-04	6.04E-05	6.51E-06	2.17E-04	5.43E-04
% of Limit	0.003%	0.001%	0.000%	0.002%	0.003%
Gaseous Effluent Dose Limit, Any Organ (Iodine, Tritium, Particulates with >8 day half-life)	7.5 mrem	7.5 mrem	7.5 mrem	7.5 mrem	15 mrem
Gaseous Effluent Organ Dose (Iodine, Tritium, Particulates with >8-Day half-life)	4.60E-02	2.59E-02	5.04E-02	5.04E-02	1.73E-01
% of Limit	0.61%	0.35%	0.67%	0.67%	1.15%

**Palisades - Table 5
2013 EPA 40 CFR Part 190, Individual in the Unrestricted Area**

	Whole Body	Thyroid	Any Other Organ
Dose Limit	25 mrem	75 mrem	25 mrem
Dose	9.79E-02	6.86E-03	5.44E-03
% of Limit	0.39%	0.01%	0.02%

ENCLOSURE 1

PALISADES NUCLEAR PLANT

OFFSITE DOSE CALCULATION MANUAL, REVISION 25

77 Pages Follow

PALISADES NUCLEAR PLANT
OFFSITE DOSE CALCULATION MANUAL

TITLE: OFFSITE DOSE CALCULATION MANUAL

Process Applicability Exclusion

DWFoster / 12/28/11
Procedure Sponsor Date

JJMiller / 12/15/11
Technical Reviewer Date

JHager / 12/15/11
User Reviewer Date

DHamilton / 12/19/11
General Manager Plant Operations Date

PALISADES NUCLEAR PLANT
OFFSITE DOSE CALCULATION MANUAL

Revision 25

Table of Contents

I.	GASEOUS EFFLUENTS	1
A.	ALARM/TRIP SETPOINT METHOD	1
	1. Allowable Concentration.....	2
	2. Monitor Response	3
B.	DOSE RATE CALCULATION.....	4
C.	GASEOUS RADWASTE TREATMENT SYSTEM OPERATION.....	19
	1. System Description	19
	2. Determination of Satisfactory Operation.....	19
D.	RELEASE RATE FOR OFFSITE EC	20
E.	PARTICULATE AND IODINE SAMPLING	20
F.	NOBLE GAS SAMPLING	21
G.	TRITIUM SAMPLING	21
H.	FIGURE – GASEOUS EFFLUENTS FLOW PATHS	22
II.	LIQUID EFFLUENTS	23
A.	CONCENTRATION	23
	1. Requirements.....	23
	2. Prerelease Analysis.....	23
	3. Effluent Concentration (EC) - Sum of the Ratios.....	24
B.	INSTRUMENT SETPOINTS.....	25
	1. Setpoint Determination	25
	2. Composite Samplers	25
	3. Post-Release Analysis	26
C.	DOSE	26
	1. RETS Requirement	26
	2. Release Analysis	26
D.	OPERABILITY OF LIQUID RADWASTE EQUIPMENT	30
E.	RELEASE RATE FOR OFFSITE EC (50 MREM/YR).....	30
F.	FIGURES	31

PALISADES NUCLEAR PLANT
OFFSITE DOSE CALCULATION MANUAL

Revision 25

Table of Contents

III.	URANIUM FUEL CYCLE DOSE	33
A.	SPECIFICATION.....	33
B.	ASSUMPTIONS	33
C.	DOSE CALCULATION	34
IV.	SOURCE REFERENCE DOCUMENTS	34
Attachment 1,	"Palisades Gaseous And Liquid Source Terms, Curies/Year"	
Attachment 2,	"Basic Radionuclide Data"	
Attachment 3,	"Dose Factors for Submersion in Noble Gases"	
Attachment 4,	"Stable Element Transfer Data"	
Attachment 5,	"Inhalation Dose Commitment Factors"	
Attachment 6,	"External Dose Factors for Standing on Contaminated Ground (DFG _i) (mrem/hr per pCi/m ²)"	
Attachment 7,	"Bioaccumulation Factors (μCi/gm per μCi/ml)"	
Attachment 8,	"Ingestion Dose Commitment Factors"	

PALISADES NUCLEAR PLANT
OFFSITE DOSE CALCULATION MANUAL

Revision 25

I. GASEOUS EFFLUENTS

A. ALARM/TRIP SETPOINT METHOD

Appendix A, Section III.B.1 requires that the dose rate due to radioactive materials released in gaseous effluents from the site to areas at and beyond the SITE BOUNDARY shall be limited to the following:

- For noble gases: Less than or equal to 500 mrems/yr to the total body and less than or equal to 3000 mrems/yr to the skin, and
- For iodine-131, for iodine-133, for tritium, and for all radionuclides in particulate form with half lives greater than 8 days: Less than or equal to 1500 mrems/yr to any organ.

Appendix A, Section III.A.1 requires gaseous effluent monitors to have alarm/trip setpoints to ensure that offsite concentrations, when averaged over 1 hour, will not be greater than Appendix A, Section III.B.1. This section of the ODCM describes the methodology that will be used to determine these setpoints.

The methodology for determining alarm/trip setpoints is divided into two major parts. The first consists of calculating an allowable concentration for the nuclide mixture to be released. The second consists of determining monitor response to this mixture in order to establish the physical settings on the monitors.

**PALISADES NUCLEAR PLANT
OFFSITE DOSE CALCULATION MANUAL**

Revision 25

1. Allowable Concentration

NOTE: If a batch release is made while a continuous release or another batch release is in progress, the sum of all values of R_k must be less than 10.0.

The total EC-fraction (R_k) for each release point will be calculated by the relationship defined by Note 4 of Appendix B, 10 CFR 20:

$$R_k = X/Q \times F \times \sum_i C_i/EC_i \leq 10.0 \quad (1.1)$$

where:

- C_i = Actual or measured concentration, at ambient temperature and pressure of nuclide i ($\mu\text{Ci/cc}$)
- EC_i = The EC of nuclide i from 10 CFR 20, Appendix B, Table 2
- $R_{(k)}$ = The total EC-fraction for release point k
- X/Q = Most conservative sector site boundary dispersion (sec/m^3) (listed in site procedure CH 6.41, Land Use Census)
- F = Release flow rate ($83,000 \text{ cfm} = 39.2 \text{ m}^3/\text{sec}$) for stack monitor considerations; variable for other monitors

PALISADES NUCLEAR PLANT
OFFSITE DOSE CALCULATION MANUAL

Revision 25

2. Monitor Response

Normal radioactivity releases consist mainly of well-decayed fission gases. Therefore, monitor response calibrations are performed to fission gas typical of normal releases (mainly Xe-133). Response of monitors used to define fission product release rates under accident conditions may vary from that of Xe-133, however. Monitor response for the two categories of monitor is determined as follows:

a. Normal Release (aged fission gasses)

Total gas concentration ($\mu\text{Ci/cc}$) at the monitor is calculated. The detector response to isotopic activities ($\text{cpm}/\mu\text{Ci/cc}$) is applied to determine cpm expected. The setting for monitor alarms is established at some factor (b) greater than 1 but less than $1/R_k$ (Equation 1.1) times the measured concentration (c):

$$s = b \times c \tag{1.2}$$

b. Accident Releases

Monitors are preset to alarm at or before precalculated offsite dose rates would be achieved under hypothetical accident conditions. These setpoints are established in accordance with Emergency Plan requirements for defining Emergency Action Levels and associated actions. Emergency Implementing Procedures contain monitor-specific curves or calibration constants for conversion between cpm and $\mu\text{Ci/cc}$ (or R/hr and $\mu\text{Ci/cc}$), depending on monitor type, for fission product mixtures as a function of mixture decay time.

When these monitors are utilized for other than accident conditions, either an appropriately decayed "accident" conversion curve may be used, or a decayed fission gas calibration factor may be applied. In these cases, setpoints are established as in 1.A above.

Setpoints of accident monitors (if set to monitor normal releases) are reset to the accident alarm settings at the end of normal release. Setpoints of other release monitors are maintained at the level used at the latest release (well below the level which would allow 10 times EC to be exceeded at the site boundary), or are reset to approximately three times background in order to detect leakage or inadvertent releases of low level gases.

PALISADES NUCLEAR PLANT
OFFSITE DOSE CALCULATION MANUAL

Revision 25

B. DOSE RATE CALCULATION

1. Dose rates are calculated for (1) noble gases and (2) iodines and particulates. Dose rates as defined in this section are based on 10 CFR 50 Appendix I limits of mrem per quarter and millirem per year. All dose pathways of major importance in the Palisades environs are considered. NRC Dose is the Effluent Dose Calculation software that supports LADTAP, GASPAR, and XOQDOQ which perform the actual dose calculations using the equations supplied here.
 - a. Equations and assumptions for calculating doses from noble gases are as follows:
 - 1) Assumptions
 - a) Doses to be calculated are the maximum offsite point in air, total body and skin.
 - b) Exposure pathway is submersion within a cloud of noble gases.
 - c) Noble gas radionuclide mix is based on the historically observed source term given in Attachment 2, plus additional nuclides.
 - d) Basic radionuclide data are given in Attachment 2.
 - e) All releases are treated as ground-level.
 - f) Meteorological data expressed as joint-frequency distribution of wind speed, wind direction, and atmospheric stability for the period resulting in X/Q's and D/Q's shown in site procedure CH 6.41, Land Use Census.
 - g) Raw meteorological data consists of wind speed and direction measurements at 10m and temperature measurements at 10m and 60m.
 - h) Dose is to be evaluated at the offsite exposure points where maximum concentrations are expected to exist (overland sector site boundaries), and nearest residents.

PALISADES NUCLEAR PLANT
OFFSITE DOSE CALCULATION MANUAL

Revision 25

- i) Potential maximum population (resident) exposure points are identified in site procedure CH 6.41, Land Use Census.
- j) A semi-infinite cloud model is used.
- k) Radioactive decay is considered for the plume.
- l) Building wake effects on effluent dispersion are considered.
- m) A sector-average dispersion equation is used.
- n) The wind speed classes that are used are as follows:

<u>Wind Speed</u> <u>Class Number</u>	<u>Range (m/s)</u>	<u>Midpoint (m/s)</u>
1	0.0-0.4	0.2
2	0.4-1.5	0.95
3	1.5-3.0	2.25
4	3.0-5.0	4.0
5	5.0-7.5	6.25
6	7.5-10.0	8.75
7	> 10.0	--

- o) The stability classes that will be used are the standard A through G classifications. The stability classes 1-7 will correspond to A=1, B=2, ..., G=7.
- p) Terrain effects are not considered.

PALISADES NUCLEAR PLANT
OFFSITE DOSE CALCULATION MANUAL

Revision 25

2) Equations

To calculate the dose for any one of the exposure points, the following equations are used.

For determining the air concentration of any radionuclide:

$$X_i = \sum_{j=1}^9 \sum_{k=1}^7 \left(\frac{2}{\pi} \right)^{1/2} \frac{f_{jk} Q_i p'}{\sum_{z=k} U_j (2\pi x/n)} \left[\exp \left(-\lambda_i \frac{x}{U_j} \right) \right] \quad (1.3)$$

where:

- X_i = Air concentration of radionuclide i, $\mu\text{Ci}/\text{m}^3$.
- f_{jk} = Joint relative frequency of occurrence of winds in wind speed class j, stability class k, blowing toward this exposure point, expressed as a fraction.
- Q_i = Average release rate of radionuclide i, $\mu\text{Ci}/\text{s}$.
- p = Fraction of radionuclide remaining in plume.
- $\sum_{z=k}$ = Vertical dispersion coefficient for stability class k (m).
- U_j = Midpoint value of wind speed class interval j, m/s.
- x = Downwind distance, m.
- n = Number of sectors, 16.
- λ_i = Radioactive decay coefficient of radionuclide i, s^{-1} .
- $2\pi x/n$ = Sector width at point of interest, m.

PALISADES NUCLEAR PLANT
OFFSITE DOSE CALCULATION MANUAL

Revision 25

For determining the total body dose rate:

$$D_{TB} = \sum_i X_i DFB_i \quad (1.4)$$

where:

D_{TB} = Total body dose rate, mrem/y.

X_i = Air concentration of radionuclide i , $\mu\text{Ci}/\text{m}^3$.

DFB_i = Total body dose factor due to gamma radiation, mrem/y per $\mu\text{Ci}/\text{m}^3$ (Attachment 3).

For determining the skin dose rate:

$$D_s = \sum_i X_i (DFS_i + 1.11 DFY_i) \quad (1.5)$$

where:

D_s = Skin dose rate, mrem/y.

X_i = Air concentration of radionuclide i , $\mu\text{Ci}/\text{m}^3$

DFS_i = Skin dose factor due to beta radiation, mrem/y per $\mu\text{Ci}/\text{m}^3$ (Attachment 3).

1.11 = The average ratio of tissue to air energy absorption coefficients, mrem/mrad.

DFY_i = Gamma-to-air dose factor for radionuclide i , mrad/y per $\mu\text{Ci}/\text{m}^3$ (Attachment 3).

For determining dose rate to a point in air:

$$D_a = \sum_i X_i (DFY_i \text{ or } DFB_i) \quad (1.6)$$

where:

D_a = Air dose rate, mrad/yr.

DFB_i = Air dose factor for beta radiation (Attachment 3).

PALISADES NUCLEAR PLANT
OFFSITE DOSE CALCULATION MANUAL

Revision 25

- b. Equations and assumptions for calculating doses from radioiodines and particulates are as follows:
- 1) Assumptions
 - a) Dose is to be calculated for the critical organ, thyroid, and the critical age groups (adult, teen, child, infant), infant (milk) and child (green, leafy vegetables).
 - b) Exposure pathways from iodines and particulates are milk ingestion, ground contamination, green leafy vegetables from home gardens, and inhalation.
 - c) The radioiodine and particulate mix is based on the historically observed source term given in Attachment 2.
 - d) Basic radionuclide data are given in Attachment 3.
 - e) All releases are treated as ground-level.
 - f) Mean annual average X/Q's are given in site procedure CH 6.41, Land Use Census.
 - g) Raw meteorological data for ground-level releases consist of wind speed and direction measurements at 10m and temperature measurements at 10m and 60m.
 - h) Dose is to be evaluated at the potential offsite exposure points where maximum doses to man are expected to exist.
 - i) Real cow, goat and garden locations are considered.
 - j) Potential maximum exposure points (site procedure CH 6.41, Land Use Census) considered are the nearest cow, goat, and home garden locations in each sector.
 - k) Terrain effects and open terrain recirculation factors are not considered.
 - l) Building wake effects on effluent dispersion are considered.
 - m) Plume depletion and radioactive decay are considered for air-concentration calculations.

PALISADES NUCLEAR PLANT
OFFSITE DOSE CALCULATION MANUAL

Revision 25

- n) Radioactive decay is considered for ground-concentration calculations.
- o) Deposition is calculated based on the curves given in Figure 1.2.
- p) Milk cows and goats obtain 100% of their food from pasture grass May through October of each year. Use default values of 0.58 for cows and 0.67 for goats for fraction of year on pasture.

2) Equations

To calculate the dose for any one of the potential maximum-exposure points, the following equations in Section 1.2.2 are used.

a) Inhalation

Equation for calculating air concentration, X_i is the same as in the Noble Gas Section (Equation 1.3).

For determining the organ dose rate:

$$D_i = 1 \times 10^6 \sum_i X_i DFI_i BR \quad (1.7)$$

where:

D_i = Organ dose rate due to inhalation, mrem/y.

X_i = Air concentration of radionuclide i , $\mu\text{Ci}/\text{m}^3$.

DFI_i = Inhalation dose factor, mrem/pCi (Attachment 5).

BR = Breathing rate 1400 m^3/y infant; 3700 m^3/y child; or 8000 m^3/y teen and adult.

1×10^6 = pCi/ μCi conversion factor.

PALISADES NUCLEAR PLANT
OFFSITE DOSE CALCULATION MANUAL

Revision 25

b) Ground Contamination

For determining the ground concentration of any nuclide;

$$G_i = 3.15 \times 10^7 \sum_{k=1}^7 \frac{f_k Q_i DR}{(2\pi x/n) \lambda_i} [1 - \exp(-\lambda_i t_b)] \quad (1.8)$$

where:

G_i = Ground concentration of radionuclide i , $\mu\text{Ci}/\text{m}^2$.

k = Stability class.

f_k = Joint relative frequency of occurrence of winds in stability class k blowing toward this exposure point, expressed as a fraction.

Q_i = Average release rate of radionuclide i , $\mu\text{Ci}/\text{s}$.

DR = Relative deposition rate, m^{-1} (Fig 1.2).

x = Downwind distance, m .

n = Number of sectors, 16.

$2\pi x/n$ = Sector width at point of interest, m .

λ_i = Radioactive decay coefficient of radionuclide i , y^{-1} .

t_b = Time for buildup of radionuclides on the ground, 15 y .

3.15×10^7 = s/y conversion factor.

**PALISADES NUCLEAR PLANT
OFFSITE DOSE CALCULATION MANUAL**

Revision 25

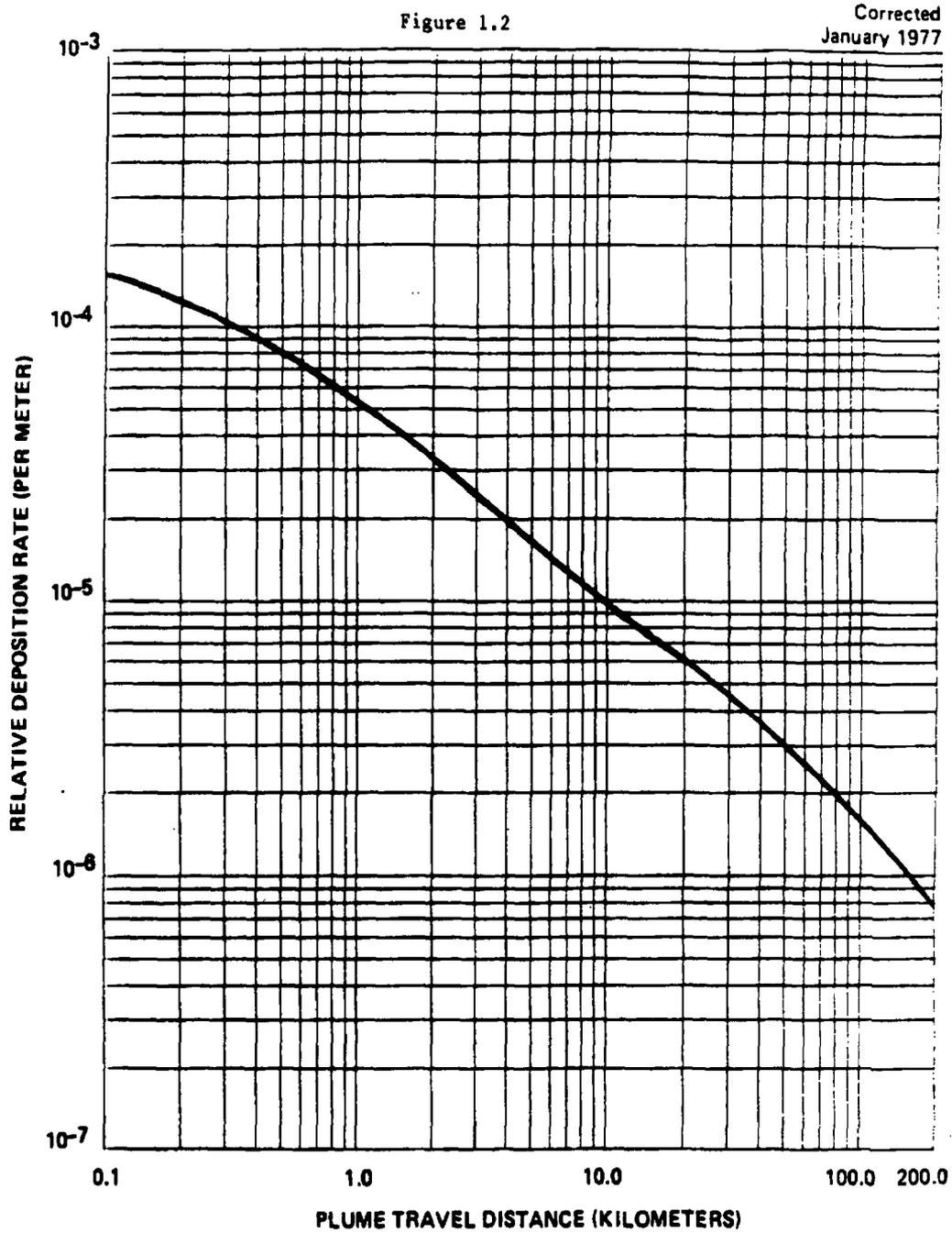

Figure 7. Relative Deposition for Ground Level Releases (All Atmospheric Stability Classes)

PALISADES NUCLEAR PLANT
OFFSITE DOSE CALCULATION MANUAL

Revision 25

For determining the total body or organ dose rate from ground contamination:

$$D_G = (8,760)(1 \times 10^6)(0.7) \sum_i G_i DFG_i \quad (1.9)$$

where:

D_G = Dose rate due to ground contamination, mrem/y.

G_i = Ground concentration of radionuclide i, $\mu\text{Ci}/\text{m}^2$.

DFG_i = Dose factor for standing on contaminated ground, mrem/h per pCi/m^2 (Attachment 6).

8,760 = Occupation time, h/y.

1×10^6 = $\text{pCi}/\mu\text{Ci}$ conversion factor.

0.7 = Shielding factor accounting for a distance of 1.0 meter above ordinary ground, dimensionless.

c) Milk and Vegetation Ingestion

For determining the concentration of any nuclide (except C-14 and H-3) in and on vegetation:

$$CV_i = 3,600 \sum_{k=1}^7 \frac{f_k Q_i DR}{(2\pi x/n)} \left(\frac{r[1 - \exp(-\lambda_{Ei} t_e)]}{Y_v \lambda_{Ei}} + \frac{B_{iv}[1 - \exp(-\lambda_i t_b)]}{P\lambda_i} \right) [\exp(-\lambda_i t_h)] \quad (1.10)$$

where:

CV_i = Concentration of radionuclide i in and on vegetation, $\mu\text{Ci}/\text{kg}$.

k = Stability class.

f_k = Frequency of this stability class and wind direction combination, expressed as a fraction.

PALISADES NUCLEAR PLANT
OFFSITE DOSE CALCULATION MANUAL

Revision 25

Q_i	=	Average release rate of radionuclide i , $\mu\text{Ci/s}$.
DR	=	Relative deposition rate, m^{-1} (Figure 1.2).
x	=	Downwind distance, m.
n	=	Number of sectors, 16.
$2\pi x/n$	=	Sector width at point of interest, m.
r	=	Fraction of deposited activity retained on vegetation (1.0 for iodines, 0.2 for particulates).
λ_{Ei}	=	Effective removal rate constant, $\lambda_{Ei} = \lambda_i + \lambda_w$, where λ_i is the radioactive decay coefficient, h^{-1} , and λ_w is a measure of physical loss by weathering ($\lambda_w = 0.0021 \text{ h}^{-1}$).
t_e	=	Period over which deposition occurs, 720 h.
Y_v	=	Agricultural yield, 0.7 kg/m^2 .
B_{iv}	=	Transfer factor from soil to vegetation of radionuclide i (Attachment 4).
λ_i	=	Radioactive decay coefficient of radionuclide i , h^{-1} .
t_b	=	Time for buildup of radionuclides on the ground, $1.31 \times 10^5 \text{ h}$ (15Y).
ρ	=	Effective surface density of soil, 240 kg/m^2 .
3,600	=	s/h conversion factor.
t_h	=	Holdup time between harvest and consumption of food (2,160 hours for stored food).

PALISADES NUCLEAR PLANT
OFFSITE DOSE CALCULATION MANUAL

Revision 25

For determining the concentration of C-14 in vegetation:

$$CV_{14} = 1 \times 10^3 X_{14} (0.11/0.16) \quad (1.11)$$

where:

CV_{14} = Concentration of C-14 in vegetation, $\mu\text{Ci}/\text{kg}$.

X_{14} = Air concentration of C-14, $\mu\text{Ci}/\text{m}^3$.

0.11 = Fraction of total Plant mass that is natural carbon.

0.16 = Concentration of natural carbon in the atmosphere, g/m^3 .

1×10^3 = g/kg conversion factor.

For determining the concentration of H-3 in vegetation:

$$CV_T = 1 \times 10^3 X_T (0.75)(0.5/H) \quad (1.12)$$

where:

CV_T = Concentration of H-3 in vegetation, $\mu\text{Ci}/\text{m}^3$.

X_T = Air concentration of H-3, $\mu\text{Ci}/\text{m}^3$.

0.75 = Fraction of total Plant mass that is water.

0.5 = Ratio of tritium concentration in Plant water to tritium concentration in atmospheric water.

H = Absolute humidity of the atmosphere, g/m^3 .

1×10^3 = g/kg conversion factor.

PALISADES NUCLEAR PLANT
OFFSITE DOSE CALCULATION MANUAL

Revision 25

For determining the concentration of any nuclide in cow's or goat's milk:

$$CM_i = CV_i FM_i Q_f \exp(-\lambda_i t_f) \quad (1.13)$$

where:

CM_i = Concentration of radionuclide i (including C-14 and H-3) in milk, $\mu\text{Ci/l}$.

CV_i = Concentration of radionuclide i in and on vegetation, $\mu\text{Ci/kg}$.

FM_i = Transfer factor from feed to milk for radionuclide i, d/l (Attachment 4).

Q_f = Amount of feed consumed by the milk animal per day, kg/d (cow, 50 kg/d or goat 6 kg/d).

Λ_i = Radioactive decay coefficient of radionuclide i, d^{-1} .

t_f = Transport time of activity from feed to milk to receptor, 2 days.

PALISADES NUCLEAR PLANT
OFFSITE DOSE CALCULATION MANUAL

Revision 25

For determining the organ dose rate from ingestion of green leafy vegetables and milk:

$$D = 1 \times 10^6 \sum_i CM_i DF_i UM \quad (1.14)$$

where:

D = Organ dose rate due to ingestion, mrem/y.

CM_i = Concentration of radionuclide i in vegetables or milk, μCi/kg (or liters).

DF_i = Ingestion dose factor, mrem/pCi (Attachment 8).

UM = Ingestion rate for milk, 330 l/y; for vegetables 26 kg/yr (child), no ingestion by infant.

1x10⁶ = pCi/μCi conversion factor.

d) Meat Ingestion (Beef)

To calculate the concentration of a nuclide in animal flesh:

$$C_{fi} = F_{fi} CV_i Q_{fi} \exp(-\lambda_i t_s) \quad (1.15)$$

where:

C_{fi} = Concentration of nuclide i in the animal flesh, pCi/kg.

F_{fi} = Fraction of animal's daily intake which appears in each kg of flesh, days/kg (Attachment 4).

CV_i = Concentration of radionuclide i in the animal's feed (Equation 1.10).

PALISADES NUCLEAR PLANT
OFFSITE DOSE CALCULATION MANUAL

Revision 25

Q_f = Amount of feed consumed by the cow per day, 50 kg/d.

t_s = Average time from slaughter to consumption, 20 days.

To determine the organ dose from ingestion of beef:

$$D^f = \sum_i C_{fi} D_{fi} U_f \quad (1.16)$$

where:

D_{fi} = Ingestion dose factor for age group, mrem/pCi (Attachment 8) for nuclide i.

U_f = Ingestion rate of meat for age group, kg/y (child-41, teen-65, adult-110).

e) Organ Dose Rates

For determining the total body and organ dose rate from iodines and particulates:

$$D = D_I + D_G + D_M + D_V + D_F \quad (1.17)$$

where:

D = Total organ dose rate, mrem/y.

D_I = Dose rate due to inhalation, mrem/y.

D_G = Dose rate due to ground contamination, mrem/y.

D_M = Dose rate due to milk ingestion, mrem/y.

D_V = Dose rate due to vegetable ingestion, mrem/y.

D_F = Dose rate due to beef ingestion, mrem/y.

PALISADES NUCLEAR PLANT
OFFSITE DOSE CALCULATION MANUAL

Revision 25

3) The maximum organ dose rate, maximum total body dose rate, and maximum skin dose rate calculated in the previous section (Sec I.B) are used to calculate design basis quantities as described in Section I.B.1.3.

c. Land Use Census

Appendix A, Sections J.3.b and J.3.c describe the requirements for an annual land use census. Changes will be effective on January 1 of the year following the year of the survey.

d. Gaseous Releases From the Steam Generator Blowdown Vent and Atmosphere Release Valves

Releases from the steam generator blowdown vent and atmospheric relief valves are difficult to quantify as there are no sampling capabilities on these steam release systems. However, neither system is a normal release path. The steam generator blowdown vent is normally routed to the main condenser and recirculated. Radioactive releases will be calculated by analyzing steam generator blowdown liquid and assuming that 100 percent of Noble Gases, 10 percent of the Iodines and 1 percent of the Particulates will be released to the environment in the steam phase. Volumes will be released to the environment in the steam phase. Volumes will be calculated using water balances or alternate means as available.

PALISADES NUCLEAR PLANT
OFFSITE DOSE CALCULATION MANUAL

Revision 25

C. GASEOUS RADWASTE TREATMENT SYSTEM OPERATION

The gaseous radwaste treatment system (GRTS) described below shall be maintained and operated to keep releases ALARA.

1. System Description

A flow diagram for the GRTS is given in Figure 1-1. The system consists of three waste-gas compressor packages, six gas decay tanks, and the associated piping, valves, and instrumentation. Gaseous wastes are received from the following: degassing of the reactor coolant and purging of the volume control tank prior to a cold shutdown and displacing of cover gases caused by liquid accumulation in the tanks connected to the vent header.

Design of the system precludes hydrogen explosion by means of ignition source elimination (diaphragm valves, low flow diaphragm compressors and system electrical grounding), and minimization of leakage outside the system. Explosive mixtures of hydrogen and oxygen have been demonstrated compatible with the system by operational experience.

2. Determination of Satisfactory Operation

Doses will be calculated for batch and continuous releases as described in Section I.B. These calculations will be used to ensure that the GRTS is operating as designed. Because the Plant was designed to collect and hold for decay a vast majority of the high level gases generated within the primary system, and because the operating history of the Plant has demonstrated the system's consistent performance well below Appendix I limits, no additional operability requirements are specified.

PALISADES NUCLEAR PLANT
OFFSITE DOSE CALCULATION MANUAL

Revision 25

D. RELEASE RATE FOR OFFSITE EC

10 CFR 20.1302 requires radioactive effluent releases to unrestricted areas be in concentrations less than the limits specified in Appendix B, Table 2 when averaged over a period not to exceed one year. (Note: there are no unrestricted areas anywhere within the site boundary as defined by Figure 1-1.) Concentrations at this level if inhaled or ingested continuously for one year will result in a dose of 50 mrem whole body except for submersion dose isotopes (gaseous tritium and noble gasses) which will result in a dose of 100 mrem whole body. 10 CFR 50.36a requires that the release of radioactive materials be kept as low as reasonably achievable. However, the section further states that the licensee is permitted the flexibility of operation, to assure a dependable source of power even under unusual operating conditions, to release quantities of material higher than a small percentage of 10 CFR 20.1302 limits but still within those limits. Appendix I to 10 CFR 50 provides the numerical guidelines on limiting conditions for operations to meet the as low as reasonably achievable requirement.

The GASPAR code has been run to determine the dose due to external radiation and inhalation. The source term used is listed in Attachment 2. The meteorology data is given in site procedure CH 6.41, Land Use Census. Dose using annual average meteorology, to the most limiting organ of the person assume to be residing at the site boundary with highest X/Q, is 2.15E-02 mrem (for one year). The release rate which would result in a dose rate equivalent to 50 mrem/year (using the more conservative total body limit) is the curies/year given in Attachment 2 multiplied by 50/2.15E-02 or 0.11 Ci/sec.

E. PARTICULATE AND IODINE SAMPLING

Particulate and iodine samples are obtained from the continuous sample stream pulled from the Plant stack. Samples typically are obtained to represent an integrated release from a gas batch (waste gas decay tank or Containment purge, for example), or a series of samples are obtained to follow the course of a release. In any event, sample intervals are weekly, at a minimum.

Because HEPA filters are present between most source inputs to the stack and the sample point, releases of particulates normally are significantly less than pre-release calculations indicate. This provides for conservatism in establishing setpoints and in estimation of pre-release dose calculations. However, for the sake of maintaining accurate release totals, monitor results (for gases) and sample results (for particulates and iodines) utilized rather than the pre-release estimates, for cumulative records.

PALISADES NUCLEAR PLANT
OFFSITE DOSE CALCULATION MANUAL

Revision 25

Gamma analytical results for particulate and halogen filters are combined for determination of total activity of particulates and halogens released. Sampling and analysis will be performed per Appendix A, Table B-1 requirements.

F. NOBLE GAS SAMPLING

Noble gases will be sampled from Waste Gas Decay Tanks prior to release and the Containment prior to purging. Analysis of these samples will be used for accountability of noble gases. Off gas will be sampled at least weekly and used to calculate monthly noble gas releases. Non-routine releases will be quantified from the stack noble gas monitor (RE 2326) which has a LLD of $1\text{E-}06 \mu\text{Ci/cc}$. Sampling and analysis will be performed per Appendix A, Table B-1 requirements.

G. TRITIUM SAMPLING

Tritium has a low dose consequence to the public because of low energy decay. The major contributors to tritium effluents are evaporation from the fuel pool and reactor cavity (when flooded). Because of the low dose impact, gaseous tritium sampling will not be required. Tritium effluents will be estimated using conservative evaporation rate calculations from the fuel pool and reactor cavity.

**PALISADES NUCLEAR PLANT
OFFSITE DOSE CALCULATION MANUAL**

Revision 25

H. FIGURE – GASEOUS EFFLUENTS FLOW PATHS

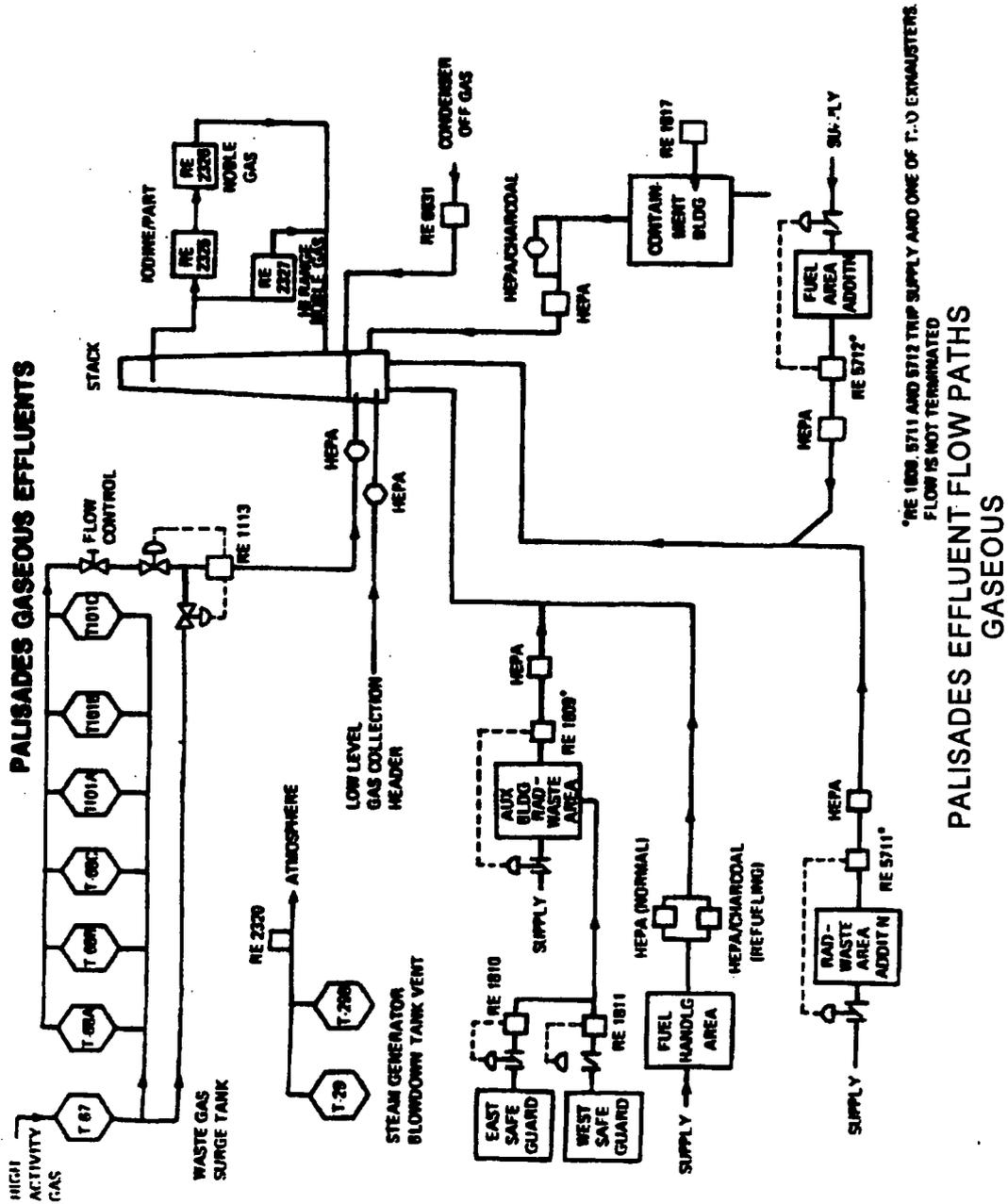

PALISADES NUCLEAR PLANT
OFFSITE DOSE CALCULATION MANUAL

Revision 25

II. LIQUID EFFLUENTS

A. CONCENTRATION

1. Requirements

Appendix A, Section III.G requires that the concentration of radioactive material released at any time from the site to unrestricted areas shall be limited to ten times the Effluent Concentration (EC) specified in 10 CFR 20, Appendix B, Table 2, Column 2 for nuclides other than dissolved or entrained noble gases. For dissolved or entrained noble gases, the concentration shall be limited to 2E-04 $\mu\text{Ci/ml}$ total activity. To ensure compliance, the following approach will be used for each release.

2. Prerelease Analysis

Most tanks will be recirculated through two volume changes prior to sampling for release to the environment to ensure that a representative sample is obtained. The appropriate recirculation time for those tanks too large to provide two volume changes will be the time that the suspended particulate concentration reaches steady state. Either a one-time test, or prior sampling data, may be used to determine appropriate recirculation time.

Prior to release, a grab sample will be analyzed for each release, and the concentration of each radionuclide determined.

$$C = \sum_{i=1}^n C_i \quad (2.1)$$

where:

C = Total concentration in the liquid effluent at the release point, $\mu\text{Ci/ml}$.

C_i = Concentration of a single radionuclide i , $\mu\text{Ci/ml}$.

PALISADES NUCLEAR PLANT
OFFSITE DOSE CALCULATION MANUAL

Revision 25

3. Effluent Concentration (EC) - Sum of the Ratios

The EC-Fraction (R_j) for each release point will be calculated by the relationship defined by Note 4 of Appendix B, 10 CFR 20:

$$R_j = \sum_i \frac{C_i}{EC_i} \leq 10.0 \quad (2.2)$$

where:

C_i = Effluent concentration of radionuclide i , $\mu\text{Ci/ml}$.

EC_i = The EC of radionuclide i , 10 CFR 20, Appendix B, Table 2, Column 2 - $\mu\text{Ci/ml}$.

R_j = The Total EC-Fraction for the release point.

The sum of the ratios at the discharge to the lake must be ≤ 10 due to the releases from any or all concurrent releases. The following relationship will assure this criterion is met:

$$f_1(R_1 - 1) + f_2(R_2 - 1) + f_3(R_3 - 1) \leq F \quad (2.3)$$

where:

f_1, f_2, f_3 = The effluent flow rate (gallons/minute) for the respective releases, determined by Plant personnel.

R_1, R_2, R_3 = The Total EC-Fractions for the respective releases as determined by Equation 2.2.

F = Minimum required dilution flow rate. Normally, a conservatively high dilution flow rate is used, that is, flow rate used = $(b_i)(F)$ where b_i is a conservative factor greater than 1.0.

PALISADES NUCLEAR PLANT
OFFSITE DOSE CALCULATION MANUAL

Revision 25

B. INSTRUMENT SETPOINTS

1. Setpoint Determination

Appendix A, Section III.F requires alarm setpoints for each liquid effluent monitor will be established using Plant instructions to ensure the requirements of Appendix A, Section III.G are not exceeded. Concentration, flow rate, dilution, principal gamma emitter, geometry, and detector efficiency are combined to give an equivalent setpoint in counts per minute (cpm). The identification number for each liquid effluent radiation detector is contained in Figure 2-2.

The respective alarm/trip setpoints at each release point will be set such that the sum of the ratios at each point, as calculated by Equation 2.2, will not be exceeded. The value of R is directly related to the total concentration calculated by Equation 2.1. An increase in the concentration would indicate an increase in the value of R. A large increase would cause the limits specified in Section 2.1.1 to be exceeded. The minimum alarm/trip setpoint value is equal to the release concentration, but for ease of operation it may be desired that the setpoint (S) be set above the effluent concentration (C) by the same factor (b) utilized in setting dilution flow. That is:

$$S = b \times C \quad (2.4)$$

Liquid effluent flow paths and release points are indicated in Figure 2.1.

2. Composite Samplers

Effluent pathways, Turbine Sump and Service Water, are equipped with continuous compositors to meet the requirements of Appendix A, Table D-1. These compositors are adjustable and normally set in a time mode and collect three to six samples hourly, 24 hours a day with a total collection of approximately one gallon per day. A representative sample is collected daily from the compositor and saved for the weekly, monthly, and quarterly analysis requirements of Appendix A, Table D-1. In the event that a compositor is not operational, effluent releases via this pathway may continue provided that grab samples are collected and analyzed for gross beta or gamma radioactivity at least once per 24 hours per Appendix A, Table C-1, Action 3.

PALISADES NUCLEAR PLANT
OFFSITE DOSE CALCULATION MANUAL

Revision 25

3. Post-Release Analysis

A post-release analysis will be done using actual release data to ensure that the limits specified in Section 1 were not exceeded.

A composite list on concentrations (C_i), by isotope, will be used with the actual liquid radwaste (f) and dilution (F) flow rates (or volumes) during the release. The data will be substituted into Equation 2.3 to demonstrate compliance with the limits in Section 1. This data and setpoints will be recorded in auditable records by Plant personnel.

C. DOSE

1. RETS Requirement

Appendix A, Section III.H.1 requires that the quantity of radionuclides released be limited such that the dose or dose commitment to an individual from radioactive materials in liquid effluents release to unrestricted areas from the reactor (see Figure 2-1) will not exceed:

- a. During any calendar quarter, 1.5 mrem to the total body and 5 mrem to any organ, and
- b. During any calendar year, 3 mrem to the total body and 10 mrem to any organ.

To ensure compliance, quantities of activity of each radionuclide released will be summed for each release and accumulated for each quarter as follows in Section 2.

2. Release Analysis

Dose calculations shall be performed for each batch release, and weekly for continuous releases unless documentation exists to demonstrate an activity below which dose limits of Section II.C.1 will not be exceeded.

a. Water Ingestion

The dose to an individual from ingestion of radioactivity from any source as described by the following equation:

$$D_j = \sum_{i=1}^i (DCF)_{ij} \times I_i \quad (2.5)$$

PALISADES NUCLEAR PLANT
OFFSITE DOSE CALCULATION MANUAL

Revision 25

where:

- D_j = Dose for the j^{th} organ from radionuclides releases, mrem.
 j = The organ of interest.
 $(DCF)_{ij}$ = Ingestion dose commitment factor for the j^{th} organ from the i^{th} radionuclide mrem/pCi, see Attachment 8.
 I_i = Activity ingested of the i^{th} radionuclide, pCi.

I_i is described by:

$$I_i = \frac{(A_i)(V)(365)}{(1000)(d)} (1E06) \quad (2.6)$$

where:

- 365 = Days per year.
 A_i = Annual activity released of i^{th} radionuclide, μCi .
 V = Average rate of water consumption (2000 ml/d - adult, 1400 ml/d - teen and child, 900 ml/d - infant, ICRP 23, p 358).
 d = Dilution water flow for year, ml.
1000 = Dispersion factor from discharge to nearest drinking water supply.
1E06 = Conversion μCi to pCi.

The dose equation then becomes:

$$D_j = \frac{(3.65E05)(V)}{d} \sum_{i=1}^i (DCF)_{ij} \times A_i \text{ mrem} \quad (2.7)$$

PALISADES NUCLEAR PLANT
OFFSITE DOSE CALCULATION MANUAL

Revision 25

b. Fish Ingestion

The dose to an individual from the consumption of fish is described by Equation 2.10. In this case, the activity ingested of the i^{th} radionuclide (I_i) is described by:

$$I_i = \frac{A_i B_i F (1E09)}{15d} = \text{pCi} \quad (2.8)$$

where:

A_i = Annual released of i^{th} radionuclide, μCi .

B_i = Fish concentration factor of i^{th} radionuclide
 $\frac{\mu\text{Ci/gm}}{\mu\text{Ci/ml}}$
 (see Attachment 7).

F = Amount of fish eaten per year (21 kg adult, 16 kg teen, 6.9 kg child, none infant).

15 = Dispersion factor from discharge to fish exposure point.

d = Dilution water flow for year, ml.

1E09 = Conversion of μCi , gm, and Kg to pCi. |

Substitution of Equation 2.8 into Equation 2.5 gives:

$$D_j = \frac{(6.7E07)F}{d} \sum_{i=1}^i A_i \times B_i \times \text{DCF}_i \text{ mrem} \quad (2.9)$$

**PALISADES NUCLEAR PLANT
OFFSITE DOSE CALCULATION MANUAL**

Revision 25

c. Annual Analysis

A complete analysis utilizing the NRC computer code LADTAP with the total source release will be done annually in conjunction with the annual environmental report. This analysis will provide estimates of dose to the total body and various organs in addition to the dose limiting organs considered in the method of Section 2. The following approach is utilized on LADTAP. The dose to the j^{th} organ from m radionuclides, D_j , is described by:

$$D_j = \sum_{i=1}^m D_{ij} \text{ mrem} \quad (2.10)$$

$$= \sum_{i=1}^m (\text{DCF})_{ij} \times I_j \text{ mrem} \quad (2.11)$$

where:

D_j = Dose to the j^{th} organ from the i^{th} radionuclide, mrem.

j = The organ of interest (bone, GI tract, thyroid, liver, kidney, lung, or total body).

$(\text{DCF})_{ij}$ = Adult ingestion dose commitment factor for the j^{th} organ from the i^{th} radionuclide, mrem/pCi (see Attachment 8).

I_i = Activity ingested of the i^{th} radionuclide, μCi .

I_i for water ingestion is described by:

$$I_i = \frac{A_i V_{\Gamma}}{v d} \mu\text{Ci} \quad (2.12)$$

and for fish ingestion I_i is described by:

$$I_i = \frac{A_i B_i F_{\Gamma}}{v d} \mu\text{Ci} \quad (2.13)$$

PALISADES NUCLEAR PLANT
OFFSITE DOSE CALCULATION MANUAL

Revision 25

where:

A_j = Activity release of j^{th} radionuclide during the year, μCi .

V = Average rate of water consumption (2000 ml/d).

Γ = Number of days during the year (365 d).

v = Dispersion factor from point of discharge to point of exposure.

d = Dilution water volume (ml).

B_i = Fish concentration factor of the i^{th} radionuclide,

Attachment 7, $\frac{\mu\text{Ci/gm}}{\mu\text{Ci/ml}}$

F = Amount of fish eaten per day (57.5 gm/d).

D. OPERABILITY OF LIQUID RADWASTE EQUIPMENT

The Palisades liquid radwaste system is designed to reduce the radioactive materials in liquid wastes prior to their discharge (through deep bed filtration and ion exchange) so that radioactivity in liquid effluent releases to unrestricted areas (see Figure 2-1) will not exceed the limits of Appendix A, III.H.1.

E. RELEASE RATE FOR OFFSITE EC (50 MREM/YR)

10 CFR 20.1302 requires radioactive effluent releases to unrestricted areas be less than the limits specified in Appendix B, Table 2 when averaged over a period not to exceed one year. Concentrations at this Effluent Concentration (EC) level, if ingested for one year, will result in a dose of 50 millirem to the total body. In addition, 10 CFR 50.36a requires that the release of radioactive materials be kept as low as is reasonably achievable. Appendix I to 10 CFR 50 provides the numerical guidelines on limiting conditions for operations to meet the as low as is reasonably achievable requirement.

The LADTAP code has been run to determine the dose due to drinking water at Plant discharge concentration (1,000 x nearest drinking water intake concentration). The nominal average source term used is given in Attachment 2. Dose to the most limiting organ of the person hypothetically drinking this water is 3.88E-03 mrem. This is only 0.13% of the more conservative 50 mrem/yr total body value.

**PALISADES NUCLEAR PLANT
OFFSITE DOSE CALCULATION MANUAL**

Revision 25

F. FIGURES

Figure 2-1

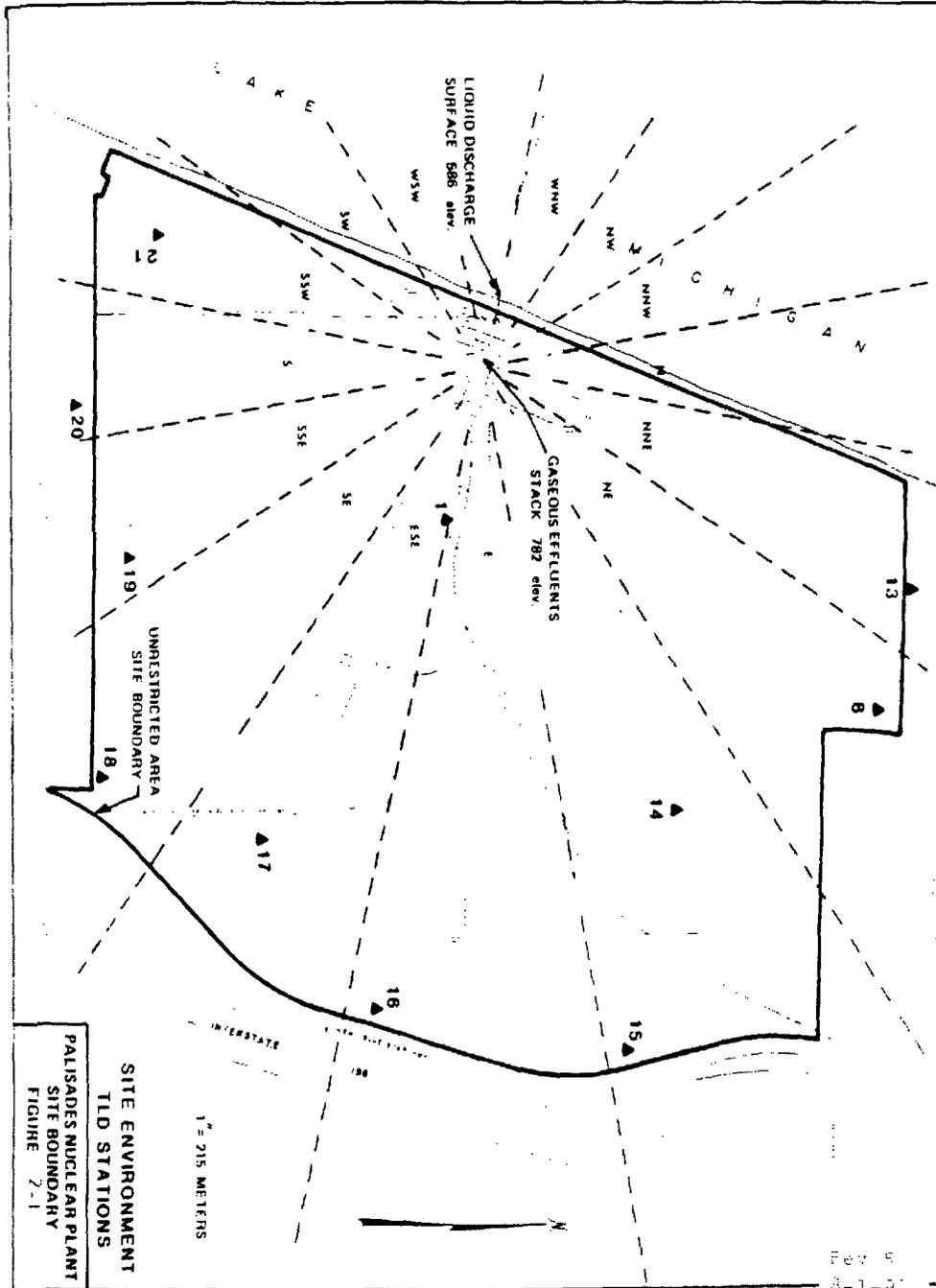

**PALISADES NUCLEAR PLANT
OFFSITE DOSE CALCULATION MANUAL**

Revision 25

Figure 2-2

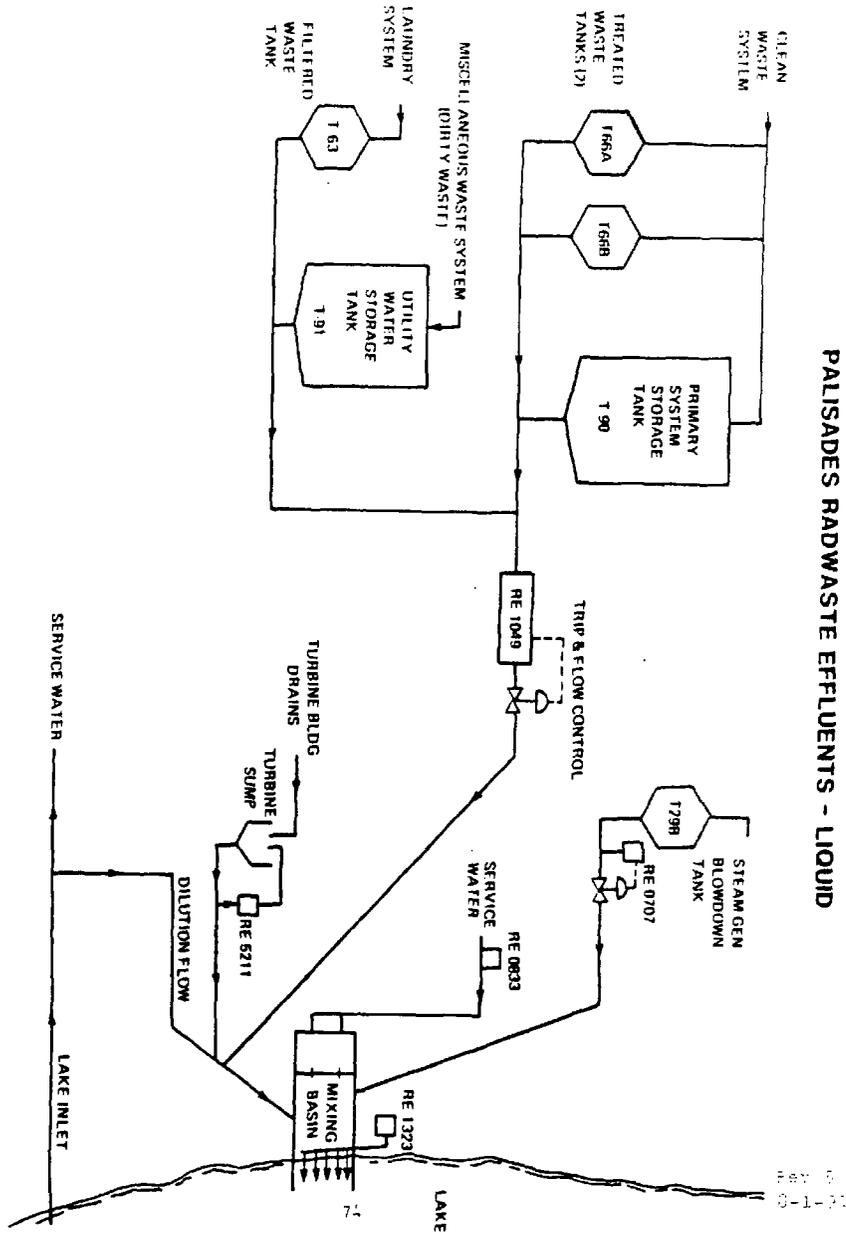

PALISADES NUCLEAR PLANT
OFFSITE DOSE CALCULATION MANUAL

Revision 25

III. URANIUM FUEL CYCLE DOSE

A. SPECIFICATION

In accordance with Appendix A, Section III.I.1, if either liquid or gaseous quarterly releases exceed the quantity which would cause offsite doses more than twice the limit of Appendix A, Sections III.C.1, III.D.1, or III.H.1, then the cumulative dose contributions from combined release plus direct radiation sources (from the reactor unit and radwaste storage tanks) shall be calculated. The dose is to be determined for the member of the public protected to be the most highly exposed to these combined sources.

B. ASSUMPTIONS

1. The full time resident determined to be maximally exposed individual (excluding infant) is assumed also to be a fisherman. This individual is assumed to drink water and ingest local fish at the rates specified in Sections II.C.2.1 and II.C.2.2.
2. Amount of shore line fishing (at accessible shoreline adjacent to site security fence) is conservatively assumed as 48 hours per quarter (average of approximately 1/2 hour per day each day of the quarter) for the second and third quarters of the year, 36 hours for the fourth quarter and 16 hours for the first quarter.

PALISADES NUCLEAR PLANT
OFFSITE DOSE CALCULATION MANUAL

Revision 25

C. DOSE CALCULATION

Maximum doses to the total body and internal organs of an individual shall be determined by use of LADTAP and GASPAP computer codes, and doses to like organs and total body summed. Added to this sum will be a mean dose rate, calculated or measured for the shoreline due to Plant present during the quarter in question, times the assumed fishing time.

$$D_{40} = D_G + D_L + (R_T)(T) \quad (2.15)$$

where:

D_{40} = 40 CFR 190 dose (mrem).

D_G = Limiting dose to an individual from gaseous source term (mrem).

D_L = Limiting dose to an individual from liquid source term (mrem).

R_T = Mean dose rate calculated to be applicable to Lake Michigan shoreline adjacent to Plant site (mrem/hr).

T = Assumed shoreline fishing time for the quarter in question (hours).

IV. SOURCE REFERENCE DOCUMENTS

1. Regulatory Guide 1.21, Measuring, Evaluating, and Reporting Radioactivity in Solid Wastes and Releases of Radioactive Materials in Liquid and Gaseous Effluents from Light-Water-Cooled Nuclear Power Plants, R1.
2. Regulatory Guide 1.109, Calculation of Annual Doses to Man from Routine Releases of Reactor Effluents for the Purpose of Evaluating Compliance with 10 CFR Part 50, Appendix I, R1.
3. NUREG-1301, Offsite Dose Calculation Manual Guidance: Standard Radiological Effluent Controls for Pressurized Water Reactors, April 91.
4. NUREG-0472, Standard Radiological Effluent Technical Specifications for Pressurized Water Reactors, R3.
5. NUREG/CR-4013, LADTAP II - Technical Reference and User Guide, April 86.
6. NUREG/CR-4653, GASPAP II - Technical Reference and User Guide, March 87.
7. CH 6.61, Revising the ODCM and ODCM Appendix A.

PALISADES GASEOUS AND LIQUID SOURCE TERMS, CURIES/YEAR (1)

<u>Nuclide</u>	<u>Gaseous(2)</u>	<u>Liquid(2)</u>
H-3	5.5	159
Kr-85	4.1	NA
Kr-85m	0.12	NA
Kr-87	8.4E-02	NA
Kr-88	2.1E-01	NA
Ar-41	3.1E-02	NA
Xe-131m	2.2	NA
Xe-133	1493	NA
Xe-133m	0.43	NA
Xe-135	1.11	NA
Xe-135m	0.3	NA
I-131	0.025	3.21E-03
I-132	2.91E-03	NA
I-133	6.5E-03	4.7E-05
I-134	4.8E-04	NA
I-135	1.84E-02	NA
Na-24	1.5E-06	NA
Cr-51	2.5E-04	3.9E-03
Mn-54	4.1E-04	7.8E-03
Co-57	2.1E-06	3.2E-05
Co-58	8.6E-04	2.9E-02
Fe-59	6.6E-06	4.1E-04
Co-60	1.1E-03	1.24E-02
Se-75	3.7E-06	NA
Nb-95	2.4E-05	4.53E-04
Zr-95	4.7E-06	1.79E-04
Mo-99	1.5E-07	NA
Ru-103	0.3E-07	0.1E-05
Sb-127	NA	3.5E-05
Cs-134	4.5E-05	0.7
Cs-136	NA	1.8E-06
Cs-137	2.6E-04	1.36E-02
Ba-140	2.8E-07	NA
La-140	7.5E-07	1.1E-04
Unidentified beta	3.9E-04	3.3E-03

(1) Data derived from taking the effluents released during July-December 1978 through January-June 1982 and dividing by 4.

(2) Nuclide values listed as NA have not been observed at detectable levels in these waste streams.

BASIC RADIONUCLIDE DATA

	<u>NUCLIDE</u>	<u>HALF-LIFE</u> (days)	<u>LAMBDA</u> (1/s)	<u>BETA¹</u> (MEV/DIS)	<u>GAMMA¹</u> (MEV/DIS)
1	Tritium	4.49E 03	1.79E-09	5.68E-03	0.0
2	C-14	2.09E 06	3.84E-12	4.95E-02	0.0
3	N-13	6.94E-03	1.16E-03	4.91E-01	1.02E 00
4	O-19	3.36E-04	2.39E-02	1.02E 00	1.05E 00
5	F-18	7.62E-02	1.05E-04	2.50E-01	1.02E 00
6	NA-24	6.33E-01	1.27E-05	5.55E-01	4.12E 00
7	P-32	1.43E 01	5.61E-07	6.95E-01	0.0
8	AR-41	7.63E-02	1.05E-04	4.64E-01	1.28E 00
9	CR-51	2.78E 01	2.89E-07	3.86E-03	3.28E-02
10	MN-54	3.03E 02	2.65E-08	3.80E-03	8.36E-01
11	MN-56	1.07E-01	7.50E-05	8.29E-01	1.69E 00
12	FE-59	4.50E 01	1.78E-07	1.18E-01	1.19E 00
13	CO-58	7.13E 01	1.12E-07	3.41E-02	9.78E-01
14	CO-60	1.92E 03	4.18E-09	9.68E-02	2.50E 00
15	ZN-69m	5.75E-01	1.39E-05	2.21E-02	4.16E-01
16	ZN-69	3.96E-02	2.03E-04	3.19E-01	0.0
17	BR-84	2.21E-02	3.63E-04	1.28E 00	1.77E 00
18	BR-85	2.08E-03	3.86E-03	1.04E 00	6.60E-02
19	KR-85m	1.83E-01	4.38E-05	2.53E-01	1.59E-01
20	KR-85	3.93E 03	2.04E-09	2.51E-01	2.21E-03
21	KR-87	5.28E-02	1.52E-04	1.32E 00	7.93E-01
22	KR-88	1.17E-01	6.86E-05	3.61E-01	1.96E 00
23	KR-89	2.21E-03	3.63E-03	1.36E 00	1.83E 00
24	RB-88	1.24E-02	6.47E-04	2.06E 00	6.26E-01
25	RB-89	1.07E-02	7.50E-04	1.01E 00	2.05E-00
26	SR-89	5.20E 01	1.54E-07	5.83E-01	8.45E-05
27	SR-90	1.03E 04	7.79E-10	1.96E-01	0.0
28	SR-91	4.03E-01	1.99E-05	6.50E-01	6.95E-01
29	SR-92	1.13E-01	7.10E-05	1.95E-01	1.34E 00
30	SR-93	5.56E-03	1.44E-03	9.20E-01	2.24E 00
31	Y-90	2.67E 00	3.00E-06	9.36E-01	0.0
32	Y-91m	3.47E-02	2.31E-04	2.73E-02	5.30E-01
33	Y-91	5.88E 01	1.36E-07	6.06E-01	3.61E-03
34	Y-92	1.47E-01	5.46E-05	1.44E 00	2.50E-01
35	Y-93	4.29E-01	1.87E-05	1.17E 00	8.94E-02
36	ZR-95	6.50E 01	1.23E-07	1.16E-01	7.35E-01
37	NB-95m	3.75E 00	2.14E-06	1.81E-01	6.06E-02
38	NB-95	3.50E 01	2.29E-07	4.44E-02	7.64E-01
39	MO-99	2.79E 00	2.87E-06	3.96E-01	1.50E-01
40	TC-99m	2.50E-01	3.21E-05	1.56E-02	1.26E-01

BASIC RADIONUCLIDE DATA

	<u>NUCLIDE</u>	<u>HALF-LIFE</u> (days)	<u>LAMBDA</u> (1/s)	<u>BETA¹</u> (MEV/DIS)	<u>GAMMA¹</u> (MEV/DIS)
41	TC-99	7.74E 07	1.04E-13	8.46E-02	0.0
42	TC-104	1.25E-02	6.42E-04	1.60E 00	1.95E 00
43	RU-106	3.67E 02	2.19E-08	1.01E-02	0.0
44	TE-132	3.24E 00	2.48E-06	1.00E-01	2.33E-01
45	I-129	6.21E 09	1.29E-15	5.43E-02	2.46E-02
46	I-131	8.05E 00	9.96E-07	1.94E-01	3.81E-01
47	I-132	9.58E-02	8.37E-05	4.89E-01	2.24E 00
48	I-133	8.75E-01	9.17E-06	4.08E-01	6.02E-01
49	I-134	3.61E-02	2.22E-04	6.16E-01	2.59E 00
50	I-135	2.79E-01	2.87E-05	3.68E-01	1.55E 00
51	XE-131m	1.18E 01	6.80E-07	1.43E-01	2.01E-02
52	XE-133m	2.26E 00	3.55E-06	1.90E-01	4.15E-02
53	XE-133	5.27E 00	1.52E-06	1.35E-01	4.60E-02
54	XE-135m	1.08E-02	7.43E-04	9.58E-02	4.32E-01
55	XE-135	3.83E-01	2.09E-05	3.17E-01	2.47E-01
56	XE-137	2.71E 03	2.96E-03	1.77E 00	1.88E-01
57	XE-138	9.84E-03	8.15E-04	6.65E-01	1.10E 00
58	CS-134	7.48E 02	1.07E-08	1.63E-01	1.55E 00
59	CS-135	1.10E 09	7.29E-15	5.63E-02	0.0
60	CS-136	1.30E 01	6.17E-07	1.37E-01	2.15E 00
61	CS-137	1.10E 04	7.29E-10	1.71E-01	5.97E-01
62	CS-138	2.24E-02	3.58E-04	1.20E 00	2.30E 00
63	BA-139	5.76E-02	1.39E-04	8.96E-01	3.53E-02
64	BA-140	1.28E 01	6.27E-07	3.15E-01	1.71E-01
65	LA-140	1.68E 00	4.77E-06	5.33E-01	2.31E 00
66	CE-144	2.84E 02	2.82E-08	9.13E-02	1.93E-02
67	PR-143	1.36E 01	5.90E-07	3.14E-01	0.0
68	PR-144	1.20E-02	6.68E-04	1.21E 00	3.18E 00

¹ Average energy per disintegration values were obtained from ICRP Publication No 38, Radionuclide Transformations: Energy and Intensity of Emissions 1983 and NUREG/CR-1413 (ORNL/NUREG-70), a Radionuclide Decay Data Base - Index and Summary Table, DC Kocher, May 1980.

DOSE FACTORS FOR SUBMERSION IN NOBLE GASES*

	Gamma body dose ¹	Gamma air dose ²	Beta skin dose ¹	Beta air dose ²
Kr-85m	1.17E3	1.23E3	1.46E3	1.97E3
Kr-85	1.61E1	1.72E1	1.34E3	1.95E3
Kr-87	5.92E3	6.17E3	9.73E3	1.03E4
Kr-88	1.47E4	1.52E4	2.37E3	2.93E3
Kr-89	1.66E4	1.73E4	1.01E4	1.06E4
Xe-131m	9.15E1	1.56E2	4.76E2	1.11E3
Xe-133m	2.51E2	3.27E2	9.94E2	1.48E3
Xe-133	2.94E2	3.53E2	3.06E2	1.05E3
Xe-135m	3.12E3	3.36E3	7.11E2	7.39E3
Xe-135	1.81E3	1.92E3	1.86E3	2.46E3
Xe-137	1.42E3	1.51E3	1.22E4	1.27E4
Xe-138	8.83E3	9.21E3	4.13E3	4.75E3
Ar-41	8.84E3	9.30E3	2.69E3	3.28E3

1. mrem/y per $\mu\text{Ci}/\text{m}^3$
2. mrad/y per $\mu\text{Ci}/\text{m}^3$

*Dose factors for exposure to a semi-infinite cloud of noble gases. Values were obtained from USNRC Regulatory Guide 1.109, Revision 1 (October 1977).

STABLE ELEMENT TRANSFER DATA

<u>ELEMENT</u>	<u>F_m - MILK (COW)</u> <u>(DAYS/L)</u>	<u>F_m - MILK (GOAT)</u> <u>(DAYS/L)</u>	<u>F_f - MEAT</u> <u>(DAYS/KG)</u>	<u>B_{iv}</u> <u>(VEG/SOIL)</u>
H	1.0E-02	1.7E-01	1.2E-02	4.8E-00
C	1.2E-02	1.0E-01	3.1E-02	5.5E-00
Na	4.0E-02	4.0E-02	3.0E-02	5.2E-02
P	2.5E-02	2.5E-01	4.6E-02	1.1E-00
Cr	2.2E-03	2.2E-03	2.4E-03	2.5E-04
Mn	2.5E-04	2.5E-04	8.0E-04	2.9E-02
Fe	1.2E-03	1.3E-04	4.0E-02	6.6E-04
Co	1.0E-03	1.0E-03	1.3E-02	9.4E-03
Ni	6.7E-03	6.7E-03	5.3E-02	1.9E-02
Cu	1.4E-02	1.3E-02	8.0E-03	1.2E-01
Zn	3.9E-02	3.9E-02	3.0E-02	4.0E-01
Rb	3.0E-02	3.0E-02	3.1E-02	1.3E-01
Sr	8.0E-04	1.4E-02	6.0E-04	1.7E-02
Y	1.0E-05	1.0E-05	4.6E-03	2.6E-03
Zr	5.0E-06	5.0E-06	3.4E-02	1.7E-04
Nb	2.5E-03	2.5E-03	2.8E-01	9.4E-03
Mo	7.5E-03	7.5E-03	8.0E-03	1.2E-01
Tc	2.5E-02	2.5E-02	4.0E-01	2.5E-01
Ru	1.0E-06	1.0E-06	4.0E-01	5.0E-02
Rh	1.0E-02	1.0E-02	1.5E-03	1.3E+01
Ag	5.0E-02	5.0E-02	1.7E-02	1.5E-01
Te	1.0E-03	1.0E-03	7.7E-02	1.3E-00
I	6.0E-03	6.0E-02	2.9E-03	2.0E-02
Cs	1.2E-02	3.0E-01	4.0E-03	1.0E-02
Ba	4.0E-04	4.0E-04	3.2E-03	5.0E-03
La	5.0E-06	5.0E-06	2.0E-04	2.5E-03
Ce	1.0E-04	1.0E-04	1.2E-03	2.5E-03
Pr	5.0E-06	5.0E-06	4.7E-03	2.5E-03
Nd	5.0E-06	5.0E-06	3.3E-03	2.4E-03
W	5.0E-04	5.0E-04	1.3E-03	1.8E-02
Np	5.0E-06	5.0E-06	2.0E-04	2.5E-03

INHALATION DOSE COMMITMENT FACTORS

INFANT INHALATION DOSE COMMITMENT FACTORS (MREM/50Y PER PCI INHALED IN FIRST YR)

ISOTOPE	BONE	LIVER	TOTAL BODY	THYROID	KIDNEY	LUNG	GI-LLI
H3*	0.	4.62E-07	4.62E-07	4.62E-07	4.62E-07	4.62E-07	4.62E-07
BE10	9.49E-04	1.25E-04	2.65E-05	0.	0.	1.49E-03	1.73E-05
C14	1.89E-05	3.79E-06	3.79E-06	3.79E-06	3.79E-06	3.79E-06	3.79E-06
N13	4.39E-08	4.39E-08	4.39E-08	4.39E-08	4.39E-08	4.39E-08	4.39E-08
F18	3.92E-06	0.	3.33E-07	0.	0.	0.	6.10E-07
NA22	7.37E-05	7.37E-05	7.37E-05	7.37E-05	7.37E-05	7.37E-05	7.37E-05
NA24	7.54E-06	7.54E-06	7.54E-06	7.54E-06	7.54E-06	7.54E-06	7.54E-06
P32	1.45E-03	8.03E-05	5.53E-05	0.	0.	0.	1.15E-05
AR39	0.	0.	0.	0.	0.	1.00E-08	0.
AR41	0.	0.	0.	0.	0.	3.14E-08	0.
CA41	7.48E-05	0.	8.16E-06	0.	0.	6.94E-02	2.96E-07
SC46	3.75E-04	5.41E-04	1.69E-04	0.	3.56E-04	0.	2.19E-05
CR51	0.	0.	6.39E-08	4.11E-08	9.45E-09	9.17E-06	2.55E-07
MN54	0.	1.81E-05	3.56E-06	0.	3.56E-06	7.14E-04	5.04E-06
MN56	0.	1.10E-09	1.58E-10	0.	7.86E-10	8.95E-06	5.12E-05
FE55	1.41E-05	8.39E-06	2.38E-06	0.	0.	6.21E-05	7.82E-07
FE59	9.69E-06	1.68E-05	6.77E-06	0.	0.	7.25E-04	1.77E-05
CO57	0.	4.65E-07	4.58E-07	0.	0.	2.71E-04	3.47E-06
CO58	0.	8.71E-07	1.30E-06	0.	0.	5.55E-04	7.95E-06
CO60	0.	5.73E-06	8.41E-06	0.	0.	3.22E-03	2.28E-05
NI59	1.81E-05	5.44E-06	3.10E-06	0.	0.	5.48E-05	6.34E-07
NI63	2.42E-04	1.46E-05	8.29E-06	0.	0.	1.49E-04	1.73E-06
NI65	1.71E-09	2.03E-10	8.79E-11	0.	0.	5.80E-06	3.58E-05
CU64	0.	1.34E-09	5.53E-10	0.	2.84E-09	6.64E-06	1.07E-05
ZN65	1.38E-05	4.47E-05	2.22E-05	0.	2.32E-05	4.62E-04	3.67E-05
ZN69M	8.98E-09	1.84E-08	1.67E-09	0.	7.45E-09	1.91E-05	2.92E-05
ZN69	3.85E-11	6.91E-11	5.13E-12	0.	2.87E-11	1.05E-06	9.44E-06
SE79	0.	2.25E-06	4.20E-07	0.	2.47E-06	2.99E-04	3.46E-06
BR82	0.	0.	9.49E-06	0.	0.	0.	0.
BR83	0.	0.	2.72E-07	0.	0.	0.	0.
BR84	0.	0.	2.86E-07	0.	0.	0.	0.
BR85	0.	0.	1.46E-08	0.	0.	0.	0.
KR83M	0.	0.	0.	0.	0.	2.50E-09	0.
KR85M	0.	0.	0.	0.	0.	1.31E-08	0.
KR85	0.	0.	0.	0.	0.	1.16E-08	0.
KR87	0.	0.	0.	0.	0.	6.59E-08	0.
KR88	0.	0.	0.	0.	0.	1.38E-07	0.
KR89	0.	0.	0.	0.	0.	8.67E-08	0.
RB86	0.	1.36E-04	6.30E-05	0.	0.	0.	2.17E-06
RB87	0.	7.11E-05	2.64E-05	0.	0.	0.	2.99E-07
RB88	0.	3.98E-07	2.05E-07	0.	0.	0.	2.42E-07
RB89	0.	2.29E-07	1.47E-07	0.	0.	0.	4.87E-08
SR89	2.84E-04	0.	8.15E-06	0.	0.	1.45E-03	4.57E-05
SR90	2.92E-02	0.	1.85E-03	0.	0.	8.03E-03	9.36E-05
SR91	6.83E-08	0.	2.47E-09	0.	0.	3.76E-05	5.24E-05
SR92	7.50E-09	0.	2.79E-10	0.	0.	1.70E-05	1.00E-04

*Includes a 50% increase to account for percutaneous transpiration.

INHALATION DOSE COMMITMENT FACTORS

INFANT INHALATION DOSE COMMITMENT FACTORS (MREM/50Y PER PCI INHALED IN FIRST YR)

ISOTOPE	BONE	LIVER	TOTAL BODY	THYROID	KIDNEY	LUNG	GI-LLI
Y90	2.35E-06	0.	6.30E-08	0.	0.	1.92E-04	7.43E-05
Y91M	2.91E-10	0.	9.90E-12	0.	0.	1.99E-06	1.68E-06
Y91	4.20E-04	0.	1.12E-05	0.	0.	1.75E-03	5.02E-05
Y92	1.17E-08	0.	3.29E-10	0.	0.	1.75E-05	9.04E-05
Y93	1.07E-07	0.	2.91E-09	0.	0.	5.46E-05	1.19E-04
ZR93	2.24E-04	9.51E-05	6.18E-05	0.	3.19E-04	1.37E-03	1.48E-05
ZR95	8.24E-05	1.99E-05	1.45E-05	0.	2.22E-05	1.25E-03	1.55E-05
ZR97	1.07E-07	1.83E-08	8.36E-09	0.	1.85E-08	7.88E-05	1.00E-04
NB93M	1.38E-04	3.59E-05	1.15E-05	0.	3.68E-05	2.09E-04	2.47E-06
NB95	1.12E-05	4.59E-06	2.70E-06	0.	3.37E-06	3.42E-04	9.05E-06
NB97	2.44E-10	5.21E-11	1.88E-11	0.	4.07E-11	2.37E-06	1.92E-05
MO93	0.	6.46E-06	2.22E-07	0.	1.54E-06	3.40E-04	3.76E-06
MO99	0.	1.18E-07	2.31E-08	0.	1.89E-07	9.63E-05	3.48E-05
TC99M	9.98E-13	2.06E-12	2.66E-11	0.	2.22E-11	5.79E-07	1.45E-06
TC99	2.09E-07	2.68E-07	8.85E-08	0.	2.49E-06	6.77E-04	7.82E-06
TC101	4.65E-14	5.88E-14	5.80E-13	0.	6.99E-13	4.17E-07	6.03E-07
RU103	1.44E-06	0.	4.85E-07	0.	3.03E-06	3.94E-04	1.15E-05
RU105	8.74E-10	0.	2.93E-10	0.	6.42E-10	1.12E-05	3.46E-05
RU106	6.20E-05	0.	7.77E-06	0.	7.61E-05	8.26E-03	1.17E-04
RH105	8.26E-09	5.41E-09	3.63E-09	0.	1.50E-08	2.08E-05	1.37E-05
PD107	0.	4.92E-07	4.11E-08	0.	2.75E-06	6.34E-05	7.33E-07
PD109	0.	3.92E-09	1.05E-09	0.	1.28E-08	1.68E-05	2.85E-05
AG110M	7.13E-06	5.16E-06	3.57E-06	0.	7.80E-06	2.62E-03	2.36E-05
AG111	3.75E-07	1.45E-07	7.75E-08	0.	3.05E-07	2.06E-04	3.02E-05
CD113M	0.	6.67E-04	2.64E-05	0.	5.80E-04	1.40E-03	1.65E-05
CD115M	0.	1.73E-04	6.19E-06	0.	9.41E-05	1.47E-03	5.02E-05
SN123	2.09E-04	4.21E-06	7.28E-06	4.27E-06	0.	2.22E-03	4.08E-05
SN125	1.01E-05	2.51E-07	6.00E-07	2.47E-07	0.	6.43E-04	7.26E-05
SN126	8.30E-04	1.44E-05	3.52E-05	3.84E-06	0.	4.93E-03	1.65E-05
SB124	2.71E-05	3.97E-07	8.56E-06	7.18E-08	0.	1.89E-03	4.22E-05
SB125	3.69E-05	3.41E-07	7.78E-06	4.45E-08	0.	1.17E-03	1.05E-05
SB126	3.08E-06	6.01E-08	1.11E-06	2.35E-08	0.	6.88E-04	5.33E-05
SB127	2.82E-07	5.04E-09	8.76E-08	3.60E-09	0.	1.54E-04	3.78E-05
TE125M	3.40E-06	1.42E-06	4.70E-07	1.16E-06	0.	3.19E-04	9.22E-06
TE127M	1.19E-05	4.93E-06	1.48E-06	3.48E-06	2.68E-05	9.37E-04	1.95E-05
TE127	1.59E-09	6.81E-10	3.49E-10	1.32E-09	3.47E-09	7.39E-06	1.74E-05
TE129M	1.01E-05	4.35E-06	1.59E-06	3.91E-06	2.27E-05	1.20E-03	4.93E-05
TE129	5.63E-11	2.48E-11	1.34E-11	4.82E-11	1.25E-10	2.14E-06	1.88E-05
TE131M	7.62E-08	3.93E-08	2.59E-08	6.38E-08	1.89E-07	1.42E-04	8.51E-05
TE131	1.24E-11	5.87E-12	3.57E-12	1.13E-11	2.85E-11	1.47E-06	5.87E-06
TE132	2.66E-07	1.69E-07	1.26E-07	1.99E-07	7.39E-07	2.43E-04	3.15E-05
TE133M	6.13E-11	3.59E-11	2.74E-11	5.52E-11	1.72E-10	3.92E-06	1.59E-05
TE134	3.18E-11	2.04E-11	1.68E-11	2.91E-11	9.59E-11	2.93E-06	2.53E-06
I129	2.16E-05	1.59E-05	1.16E-05	1.04E-02	1.88E-05	0.	2.12E-07
I130	4.54E-06	9.91E-06	3.98E-06	1.14E-03	1.09E-05	0.	1.42E-06
I131	2.71E-05	3.17E-05	1.40E-05	1.06E-02	3.70E-05	0.	7.56E-07

INHALATION DOSE COMMITMENT FACTORS

INFANT INHALATION DOSE COMMITMENT FACTORS (MREM/50Y PER PCI INHALED IN FIRST YR)

ISOTOPE	BONE	LIVER	TOTAL BODY	THYROID	KIDNEY	LUNG	GI-LLI
I132	1.21E-06	2.53E-06	8.99E-07	1.21E-04	2.82E-06	0.	1.36E-06
I133	9.46E-06	1.37E-05	4.00E-06	2.54E-03	1.60E-05	0.	1.54E-06
I134	6.58E-07	1.34E-06	4.75E-07	3.18E-05	1.49E-06	0.	9.21E-07
I135	2.76E-06	5.43E-06	1.98E-06	4.97E-04	6.05E-06	0.	1.31E-06
XE131M	0.	0.	0.	0.	0.	6.77E-09	0.
XE133M	0.	0.	0.	0.	0.	8.89E-09	0.
XE133	0.	0.	0.	0.	0.	7.41E-09	0.
XE135M	0.	0.	0.	0.	0.	8.05E-09	0.
XE135	0.	0.	0.	0.	0.	1.80E-08	0.
XE137	0.	0.	0.	0.	0.	8.30E-08	0.
XE138	0.	0.	0.	0.	0.	9.78E-08	0.
CS134M	1.32E-07	2.10E-07	1.11E-07	0.	8.50E-08	2.00E-08	1.16E-07
CS134	2.83E-04	5.02E-04	5.32E-05	0.	1.36E-04	5.69E-05	9.53E-07
CS135	1.00E-04	8.66E-05	4.73E-06	0.	2.58E-05	1.01E-05	2.18E-07
CS136	3.45E-05	9.61E-05	3.78E-05	0.	4.03E-05	8.40E-06	1.02E-06
CS137	3.92E-04	4.37E-04	3.25E-05	0.	1.23E-04	5.09E-05	9.53E-07
CS138	3.61E-07	5.58E-07	2.84E-07	0.	2.93E-07	4.67E-08	6.26E-07
CS139	2.32E-07	3.03E-07	1.22E-07	0.	1.65E-07	2.53E-08	1.33E-08
BA139	1.06E-09	7.03E-13	3.07E-11	0.	4.23E-13	4.25E-06	3.64E-05
BA140	4.00E-05	4.00E-08	2.07E-06	0.	9.59E-09	1.14E-03	2.74E-05
BA141	1.12E-10	7.70E-14	3.55E-12	0.	4.64E-14	2.12E-06	3.39E-06
BA142	2.84E-11	2.36E-14	1.40E-12	0.	1.36E-14	1.11E-06	4.95E-07
LA140	3.61E-07	1.43E-07	3.68E-08	0.	0.	1.20E-04	6.06E-05
LA141	4.85E-09	1.40E-09	2.45E-10	0.	0.	1.22E-05	5.96E-05
LA142	7.36E-10	2.69E-10	6.46E-11	0.	0.	5.87E-06	4.25E-05
CE141	1.98E-05	1.19E-05	1.42E-06	0.	3.75E-06	3.69E-04	1.54E-05
CE143	2.09E-07	1.38E-07	1.58E-08	0.	4.03E-08	8.30E-05	3.55E-05
CE144	2.28E-03	8.65E-04	1.26E-04	0.	3.84E-04	7.03E-03	1.06E-04
PR143	1.00E-05	3.74E-06	4.99E-07	0.	1.41E-06	3.09E-04	2.66E-05
PR144	3.42E-11	1.32E-11	1.72E-12	0.	4.80E-12	1.15E-06	3.06E-06
ND147	5.67E-06	5.81E-06	3.57E-07	0.	2.25E-06	2.30E-04	2.23E-05
PM147	3.91E-04	3.07E-05	1.56E-05	0.	4.93E-05	4.55E-04	5.75E-06
PM148M	5.00E-05	1.24E-05	9.94E-06	0.	1.45E-05	1.22E-03	3.37E-05
PM148	3.34E-06	4.82E-07	2.44E-07	0.	5.76E-07	3.20E-04	6.04E-05
PM149	3.10E-07	4.08E-08	1.78E-08	0.	4.96E-08	6.50E-05	3.01E-05
PM151	7.52E-08	1.10E-08	5.55E-09	0.	1.30E-08	3.25E-05	2.58E-05
SM151	3.38E-04	6.45E-05	1.63E-05	0.	5.24E-05	2.98E-04	3.46E-06
SM153	1.53E-07	1.18E-07	9.06E-09	0.	2.47E-08	3.70E-05	1.93E-05
EU152	7.83E-04	1.77E-04	1.72E-04	0.	5.94E-04	1.48E-03	9.88E-06
EU154	2.96E-03	3.46E-04	2.45E-04	0.	1.14E-03	3.05E-03	2.84E-05
EU155	5.97E-04	5.72E-05	3.46E-05	0.	1.58E-04	5.20E-04	5.19E-05
EU156	1.56E-05	9.59E-06	1.54E-06	0.	4.48E-06	6.12E-04	4.14E-05
TB160	1.12E-04	0.	1.40E-05	0.	3.20E-05	1.11E-03	2.14E-05
HO166M	1.45E-03	3.07E-04	2.51E-04	0.	4.22E-04	2.05E-03	1.65E-05
W181	4.86E-08	1.46E-08	1.67E-09	0.	0.	1.33E-05	2.63E-07
W185	1.57E-06	4.83E-07	5.58E-08	0.	0.	4.48E-04	1.12E-05
W187	9.26E-09	6.44E-09	2.23E-09	0.	0.	2.83E-05	2.54E-05

INHALATION DOSE COMMITMENT FACTORS

INFANT INHALATION DOSE COMMITMENT FACTORS (MREM/50Y PER PCI INHALED IN FIRST YR)

ISOTOPE	BONE	LIVER	TOTAL BODY	THYROID	KIDNEY	LUNG	GI-LLI
PB210	8.62E-02	2.02E-02	3.43E-03	0.	6.85E-02	1.76E-01	3.79E-05
BI210	0.	1.33E-05	1.18E-06	0.	1.03E-04	9.96E-03	3.27E-05
PO210	2.98E-03	5.63E-03	7.12E-04	0.	1.30E-02	2.40E-01	4.36E-05
RN222	0.	0.	0.	0.	0.	9.88E-06	0.
RA223	1.56E-03	2.26E-06	3.12E-04	0.	4.16E-05	2.25E-01	3.04E-04
RA224	1.77E-04	4.00E-07	3.54E-05	0.	7.30E-06	7.91E-02	3.42E-04
RA225	2.57E-03	2.88E-06	5.13E-04	0.	5.31E-05	2.57E-01	2.87E-04
RA226	2.48E-01	1.46E-05	2.05E-01	0.	2.94E-04	7.83E-01	3.05E-04
RA228	1.60E-01	7.61E-06	1.80E-01	0.	1.53E-04	1.09E-00	5.19E-05
AC225	3.69E-03	4.72E-03	2.48E-04	0.	3.49E-04	1.96E-01	2.71E-04
AC227	5.29E+00	8.76E-01	3.28E-01	0.	1.86E-01	1.62E+00	5.27E-05
TH227	1.82E-03	3.03E-05	5.24E-05	0.	1.13E-04	3.27E-01	3.53E-04
TH228	8.46E-01	1.10E-02	2.86E-02	0.	5.61E-02	4.65E+00	3.62E-04
TH229	1.34E+01	1.82E-01	6.62E-01	0.	8.99E-01	1.22E+01	3.29E-04
TH230	3.46E+00	1.79E-01	9.65E-02	0.	8.82E-01	2.18E+00	3.87E-05
TH232	3.86E+00	1.53E-01	2.29E-01	0.	7.54E-01	2.09E+00	3.29E-05
TH234	1.33E-05	7.17E-07	3.84E-07	0.	2.70E-06	1.62E-03	7.40E-05
PA231	9.10E+00	3.00E-01	3.62E-01	0.	1.62E+00	3.85E-01	4.61E-05
PA233	6.84E-06	1.32E-06	1.19E-06	0.	3.68E-06	2.19E-04	9.04E-06
U232	2.57E-01	0.	2.13E-02	0.	2.40E-02	1.49E+00	4.36E-05
U233	5.44E-02	0.	3.83E-03	0.	1.09E-02	3.56E-01	4.03E-05
U234	5.22E-02	0.	3.75E-03	0.	1.07E-02	3.49E-01	3.95E-05
U235	5.01E-02	0.	3.52E-03	0.	1.01E-02	3.28E-01	5.02E-05
U236	5.01E-02	0.	3.60E-03	0.	1.03E-02	3.35E-01	3.71E-05
U237	3.25E-07	0.	8.65E-08	0.	8.08E-07	9.13E-05	1.31E-05
U238	4.79E-02	0.	3.29E-03	0.	9.40E-03	3.06E-01	3.54E-05
NP237	3.03E+00	2.32E-01	1.26E-01	0.	7.69E-01	3.49E-01	5.10E-05
NP238	2.67E-06	6.73E-08	4.16E-08	0.	1.47E-07	9.19E-05	2.58E-05
NP239	2.65E-07	2.37E-08	1.34E-08	0.	4.73E-08	4.25E-05	1.78E-05
PU238	5.02E+00	6.33E-01	1.27E-01	0.	4.64E-01	9.03E-01	4.69E-05
PU239	5.50E+00	6.72E-01	1.34E-01	0.	4.95E-01	8.47E-01	4.28E-05
PU240	6.49E+00	6.71E-01	1.34E-01	0.	4.94E-01	8.47E-01	4.36E-05
PU241	1.55E-01	6.69E-03	3.11E-03	0.	1.15E-02	7.62E-04	8.97E-07
PU242	5.09E+00	6.47E-01	1.29E-01	0.	4.77E-01	8.15E-01	4.20E-05
PU244	5.95E+00	7.40E-01	1.48E-01	0.	5.46E-01	9.33E-01	6.26E-05
AM241	1.84E+00	8.44E-01	1.31E-01	0.	7.94E-01	4.06E-01	4.78E-05
AM242M	1.90E+00	8.24E-01	1.35E-01	0.	8.03E-01	1.64E-01	6.01E-05
AM243	1.82E+00	8.10E-01	1.27E-01	0.	7.72E-01	3.85E-01	5.60E-05
CM242	8.58E-02	7.44E-02	5.70E-03	0.	1.69E-02	2.97E-01	5.10E-05
CM243	1.73E+00	7.94E-01	1.06E-01	0.	3.91E-01	4.24E-01	5.02E-05
CM244	1.43E+00	7.04E-01	8.89E-02	0.	3.21E-01	4.08E-01	4.86E-05
CM245	2.26E+00	8.80E-01	1.36E-01	0.	5.23E-01	3.92E-01	4.53E-05
CM246	2.24E+00	8.79E-01	1.36E-01	0.	5.23E-01	3.99E-01	4.45E-05
CM247	2.18E+00	8.64E-01	1.33E-01	0.	5.15E-01	3.92E-01	5.85E-05
CM248	1.82E+01	7.12E+00	1.10E+00	0.	4.24E+00	3.23E+00	9.43E-04
CF252	4.26E+00	0.	1.01E-01	0.	0.	1.37E+00	1.85E-04

INHALATION DOSE COMMITMENT FACTORS

CHILD INHALATION DOSE COMMITMENT FACTORS (MREM/50Y PER PCI INHALED IN FIRST YR)

ISOTOPE	BONE	LIVER	TOTAL BODY	THYROID	KIDNEY	LUNG	GI-LLI
H3*	0.	3.04E-07	3.04E-07	3.04E-07	3.04E-07	3.04E-07	3.04E-07
BE10	8.43E-04	9.83E-05	2.12E-05	0.	0.	7.41E-04	1.72E-05
C14	9.70E-06	1.82E-06	1.82E-06	1.82E-06	1.82E-06	1.82E-06	1.82E-06
N13	2.33E-08	2.33E-08	2.33E-08	2.33E-08	2.33E-08	2.33E-08	2.33E-08
F18	1.88E-06	0.	1.85E-07	0.	0.	0.	3.37E-07
NA22	4.41E-05	4.41E-05	4.41E-05	4.41E-05	4.41E-05	4.41E-05	4.41E-05
NA24	4.35E-06	4.35E-06	4.35E-06	4.35E-06	4.35E-06	4.35E-06	4.35E-06
P32	7.04E-04	3.09E-05	2.67E-05	0.	0.	0.	1.14E-05
AR39	0.	0.	0.	0.	0.	4.89E-09	0.
AR41	0.	0.	0.	0.	0.	1.68E-08	0.
CA41	7.06E-05	0.	7.70E-06	0.	0.	7.21E-02	2.94E-07
SC46	1.97E-04	2.70E-04	1.04E-04	0.	2.39E-04	0.	2.45E-05
CR51	0.	0.	4.17E-08	2.31E-08	6.57E-09	4.59E-06	2.93E-07
MN54	0.	1.16E-05	2.57E-06	0.	2.71E-06	4.26E-04	6.19E-06
MN56	0.	4.48E-10	8.43E-11	0.	4.52E-10	3.55E-06	3.33E-05
FE55	1.28E-05	6.80E-06	2.10E-06	0.	0.	3.00E-05	7.75E-07
FE59	5.59E-06	9.04E-06	4.51E-06	0.	0.	3.43E-04	1.91E-05
CO57	0.	2.44E-07	2.88E-07	0.	0.	1.37E-04	3.58E-06
CO58	0.	4.79E-07	8.55E-07	0.	0.	2.99E-04	9.29E-06
CO60	0.	3.55E-06	6.12E-06	0.	0.	1.91E-03	2.60E-05
NI59	1.66E-05	4.67E-06	2.83E-06	0.	0.	2.73E-05	6.29E-07
NI63	2.22E-04	1.25E-05	7.56E-06	0.	0.	7.43E-05	1.71E-06
NI65	8.08E-10	7.99E-11	4.44E-11	0.	0.	2.21E-06	2.27E-05
CU64	0.	5.39E-10	2.90E-10	0.	1.63E-09	2.59E-06	9.92E-06
ZN65	1.15E-05	3.06E-05	1.90E-05	0.	1.93E-05	2.69E-04	4.41E-06
ZN69M	4.26E-09	7.28E-09	8.59E-10	0.	4.22E-09	7.36E-06	2.71E-05
ZN69	1.81E-11	2.61E-11	2.41E-12	0.	1.58E-11	3.84E-07	2.75E-06
SE79	0.	1.23E-06	2.60E-07	0.	1.71E-06	1.49E-04	3.43E-06
BR82	0.	0.	5.66E-06	0.	0.	0.	0.
BR83	0.	0.	1.28E-07	0.	0.	0.	0.
BR84	0.	0.	1.48E-07	0.	0.	0.	0.
BR85	0.	0.	6.84E-09	0.	0.	0.	0.
KR83M	0.	0.	0.	0.	0.	1.22E-09	0.
KR85M	0.	0.	0.	0.	0.	6.58E-09	0.
KR85	0.	0.	0.	0.	0.	5.66E-09	0.
KR87	0.	0.	0.	0.	0.	3.38E-08	0.
KR88	0.	0.	0.	0.	0.	6.99E-08	0.
KR89	0.	0.	0.	0.	0.	4.55E-08	0.
RB86	0.	5.36E-05	3.09E-05	0.	0.	0.	2.16E-06
RB87	0.	3.16E-05	1.37E-05	0.	0.	0.	2.96E-07
RB88	0.	1.52E-07	9.90E-08	0.	0.	0.	4.66E-09
RB89	0.	9.33E-08	7.83E-08	0.	0.	0.	5.11E-10
SR89	1.62E-04	0.	4.66E-06	0.	0.	5.83E-04	4.52E-05
SR90	2.73E-02	0.	1.74E-03	0.	0.	3.99E-03	9.28E-05
SR91	3.28E-08	0.	1.24E-09	0.	0.	1.44E-05	4.70E-05
SR92	3.54E-09	0.	1.42E-10	0.	0.	6.49E-06	6.55E-05

*Includes a 50% increase to account for percutaneous transpiration.

INHALATION DOSE COMMITMENT FACTORS

CHILD INHALATION DOSE COMMITMENT FACTORS (MREM/50Y PER PCI INHALED IN FIRST YR)

ISOTOPE	BONE	LIVER	TOTAL BODY	THYROID	KIDNEY	LUNG	GI-LLI
Y90	1.11E-06	0.	2.99E-08	0.	0.	7.07E-05	7.24E-05
Y91M	1.37E-10	0.	4.98E-12	0.	0.	7.60E-07	4.64E-07
Y91	2.47E-04	0.	6.59E-06	0.	0.	7.10E-04	4.97E-05
Y92	5.50E-09	0.	1.57E-10	0.	0.	6.46E-06	6.46E-05
Y93	5.04E-08	0.	1.38E-09	0.	0.	2.01E-05	1.05E-04
ZR93	2.07E-04	7.80E-05	5.55E-05	0.	3.00E-04	7.10E-04	1.47E-05
ZR95	5.13E-05	1.13E-05	1.00E-05	0.	1.61E-05	6.03E-04	1.65E-05
ZR97	5.07E-08	7.34E-09	4.32E-09	0.	1.05E-08	3.06E-05	9.49E-05
NB93M	1.27E-04	3.17E-05	1.04E-05	0.	3.44E-05	1.04E-04	2.45E-06
NB95	6.35E-06	2.48E-06	1.77E-06	0.	2.33E-06	1.66E-04	1.00E-05
NB97	1.16E-10	2.08E-11	9.74E-12	0.	2.31E-11	9.23E-07	7.52E-06
MO93	0.	3.76E-06	1.35E-07	0.	1.06E-06	1.70E-04	3.78E-06
MO99	0.	4.66E-08	1.15E-08	0.	1.06E-07	3.66E-05	3.42E-05
TC99M	4.81E-13	9.41E-13	1.56E-11	0.	1.37E-11	2.57E-07	1.30E-06
TC99	1.34E-07	1.49E-07	5.35E-08	0.	1.75E-06	3.37E-04	7.75E-06
TC101	2.19E-14	2.30E-14	2.91E-13	0.	3.92E-13	1.58E-07	4.41E-09
RU103	7.55E-07	0.	2.90E-07	0.	1.90E-06	1.79E-04	1.21E-05
RU105	4.13E-10	0.	1.50E-10	0.	3.63E-10	4.30E-06	2.69E-05
RU106	3.68E-05	0.	4.57E-06	0.	4.97E-05	3.87E-03	1.16E-04
RH105	3.91E-09	2.10E-09	1.79E-09	0.	8.39E-09	7.82E-06	1.33E-05
PD107	0.	2.65E-07	2.51E-08	0.	1.97E-06	3.16E-05	7.26E-07
PD109	0.	1.48E-09	4.95E-10	0.	7.06E-09	6.16E-06	2.59E-05
AG110M	4.56E-06	3.08E-06	2.47E-06	0.	5.74E-06	1.48E-03	2.71E-05
AG111	1.81E-07	5.68E-08	3.75E-08	0.	1.71E-07	7.73E-05	2.98E-05
CD113M	0.	4.93E-04	2.12E-05	0.	5.13E-04	6.94E-04	1.63E-05
CD115M	0.	7.88E-05	3.39E-06	0.	5.93E-05	5.86E-04	4.97E-05
SN123	1.29E-04	2.14E-06	4.19E-06	2.27E-06	0.	9.59E-04	4.05E-05
SN125	4.95E-06	9.94E-08	2.95E-07	1.03E-07	0.	2.43E-04	7.17E-05
SN126	6.23E-04	1.04E-05	2.36E-05	2.84E-06	0.	3.02E-03	1.63E-05
SB124	1.55E-05	2.00E-07	5.41E-06	3.41E-08	0.	8.76E-04	4.43E-05
SB125	2.66E-05	2.05E-07	5.59E-06	2.46E-08	0.	6.27E-04	1.09E-05
SB126	1.72E-06	2.62E-08	6.16E-07	1.00E-08	0.	2.86E-04	5.67E-05
SB127	1.36E-07	2.09E-09	4.70E-08	1.51E-09	0.	6.17E-05	3.82E-05
TE125M	1.82E-06	6.29E-07	2.47E-07	5.20E-07	0.	1.29E-04	9.13E-06
TE127M	6.72E-06	2.31E-06	8.16E-07	1.64E-06	1.72E-05	4.00E-04	1.93E-05
TE127	7.49E-10	2.57E-10	1.65E-10	5.30E-10	1.91E-09	2.71E-06	1.52E-05
TE129M	5.19E-06	1.85E-06	8.22E-07	1.71E-06	1.36E-05	4.76E-04	4.91E-05
TE129	2.64E-11	9.45E-12	6.44E-12	1.93E-11	6.94E-11	7.93E-07	6.89E-06
TE131M	3.63E-08	1.60E-08	1.37E-08	2.64E-08	1.08E-07	5.56E-05	8.32E-05
TE131	5.87E-12	2.28E-12	1.78E-12	4.59E-12	1.59E-11	5.55E-07	3.60E-07
TE132	1.30E-07	7.36E-08	7.12E-08	8.58E-08	4.79E-07	1.02E-04	3.72E-05
TE133M	2.93E-11	1.51E-11	1.50E-11	2.32E-11	1.01E-10	1.60E-06	4.77E-06
TE134	1.53E-11	8.81E-12	9.40E-12	1.24E-11	5.71E-11	1.23E-06	4.87E-07
I129	1.05E-05	6.40E-06	5.71E-06	4.28E-03	1.08E-05	0.	2.15E-07
I130	2.21E-06	4.43E-06	2.28E-06	4.99E-04	6.61E-06	0.	1.38E-06
I131	1.30E-05	1.30E-05	7.37E-06	4.39E-03	2.13E-05	0.	7.68E-07

INHALATION DOSE COMMITMENT FACTORS

CHILD INHALATION DOSE COMMITMENT FACTORS (MREM/50Y PER PCI INHALED IN FIRST YR)

ISOTOPE	BONE	LIVER	TOTAL BODY	THYROID	KIDNEY	LUNG	GI-LLI
I132	5.72E-07	1.10E-06	5.07E-07	5.23E-05	1.69E-06	0.	8.65E-07
I133	4.48E-06	5.49E-06	2.08E-06	1.04E-03	9.13E-06	0.	1.48E-06
I134	3.17E-07	5.84E-07	2.69E-07	1.37E-05	8.92E-07	0.	2.58E-07
I135	1.33E-06	2.36E-06	1.12E-06	2.14E-04	3.62E-06	0.	1.20E-06
XE131M	0.	0.	0.	0.	0.	3.30E-09	0.
XE133M	0.	0.	0.	0.	0.	4.36E-09	0.
XE133	0.	0.	0.	0.	0.	3.66E-09	0.
XE135M	0.	0.	0.	0.	0.	4.48E-09	0.
XE135	0.	0.	0.	0.	0.	9.09E-09	0.
XE137	0.	0.	0.	0.	0.	4.07E-08	0.
XE138	0.	0.	0.	0.	0.	5.17E-08	0.
CS134M	6.33E-08	8.92E-08	6.12E-08	0.	4.94E-08	8.35E-09	7.92E-08
CS134	1.76E-04	2.74E-04	6.07E-05	0.	8.93E-05	3.27E-05	1.04E-06
CS135	6.23E-05	4.13E-05	4.45E-06	0.	1.53E-05	5.22E-06	2.17E-07
CS136	1.76E-05	4.62E-05	3.14E-05	0.	2.58E-05	3.93E-06	1.13E-06
CS137	2.45E-04	2.23E-04	3.47E-05	0.	7.63E-05	2.81E-05	9.78E-07
CS138	1.71E-07	2.27E-07	1.50E-07	0.	1.68E-07	1.84E-08	7.29E-08
CS139	1.09E-07	1.15E-07	5.80E-08	0.	9.08E-08	9.36E-09	7.23E-12
BA139	4.98E-10	2.66E-13	1.45E-11	0.	2.33E-13	1.56E-06	1.56E-05
BA140	2.00E-05	1.75E-08	1.17E-06	0.	5.71E-09	4.71E-04	2.75E-05
BA141	5.29E-11	2.95E-14	1.72E-12	0.	2.56E-14	7.89E-07	7.44E-08
BA142	1.35E-11	9.73E-15	7.54E-13	0.	7.87E-15	4.44E-07	7.41E-10
LA140	1.74E-07	6.08E-08	2.04E-08	0.	0.	4.94E-05	6.10E-05
LA141	2.28E-09	5.31E-10	1.15E-10	0.	0.	4.48E-06	4.37E-05
LA142	3.50E-10	1.11E-10	3.49E-11	0.	0.	2.35E-06	2.05E-05
CE141	1.06E-05	5.28E-06	7.83E-07	0.	2.31E-06	1.47E-04	1.53E-05
CE143	9.89E-08	5.37E-08	7.77E-09	0.	2.26E-08	3.12E-05	3.44E-05
CE144	1.83E-03	5.72E-04	9.77E-05	0.	3.17E-04	3.23E-03	1.05E-04
PR143	4.99E-06	1.50E-06	2.47E-07	0.	8.11E-07	1.17E-04	2.63E-05
PR144	1.61E-11	4.99E-12	8.10E-13	0.	2.64E-12	4.23E-07	5.32E-08
ND147	2.92E-06	2.36E-06	1.84E-07	0.	1.30E-06	8.87E-05	2.22E-05
PM147	3.52E-04	2.52E-05	1.36E-05	0.	4.45E-05	2.20E-04	5.70E-06
PM148M	3.31E-05	6.55E-06	6.55E-06	0.	9.74E-06	5.72E-04	3.58E-05
PM148	1.61E-06	1.94E-07	1.25E-07	0.	3.30E-07	1.24E-04	6.01E-05
PM149	1.47E-07	1.56E-08	8.45E-09	0.	2.75E-08	2.40E-05	2.92E-05
PM151	3.57E-08	4.33E-09	2.82E-09	0.	7.35E-09	1.24E-05	2.50E-05
SM151	3.14E-04	4.75E-05	1.49E-05	0.	4.89E-05	1.48E-04	3.43E-06
SM153	7.24E-08	4.51E-08	4.35E-09	0.	1.37E-08	1.37E-05	1.87E-05
EU152	7.42E-04	1.37E-04	1.61E-04	0.	5.73E-04	9.00E-04	1.14E-05
EU154	2.74E-03	2.49E-04	2.27E-04	0.	1.09E-03	1.66E-03	2.98E-05
EU155	5.60E-04	4.05E-05	3.18E-05	0.	1.51E-04	2.79E-04	5.39E-05
EU156	7.89E-06	4.23E-06	8.75E-07	0.	2.72E-06	2.54E-04	4.24E-05
TB160	7.79E-05	0.	9.67E-06	0.	2.32E-05	5.34E-04	2.28E-05
HO166M	1.34E-03	2.81E-04	2.37E-04	0.	4.01E-04	1.13E-03	1.63E-05
W181	2.66E-08	6.52E-09	8.99E-10	0.	0.	5.71E-06	2.61E-07
W185	8.31E-07	2.08E-07	2.91E-08	0.	0.	1.86E-04	1.11E-05
W187	4.41E-09	2.61E-09	1.17E-09	0.	0.	1.11E-05	2.46E-05

INHALATION DOSE COMMITMENT FACTORS

CHILD INHALATION DOSE COMMITMENT FACTORS (MREM/50Y PER PCI INHALED IN FIRST YR)

ISOTOPE	BONE	LIVER	TOTAL BODY	THYROID	KIDNEY	LUNG	GI-LLI
PB210	8.03E-02	1.85E-02	3.18E-03	0.	6.31E-02	8.74E-02	3.75E-05
BI210	0.	5.11E-06	5.65E-07	0.	5.76E-05	3.70E-03	3.21E-05
PO210	1.70E-03	2.76E-03	4.09E-04	0.	8.85E-03	1.05E-01	4.32E-05
RN222	0.	0.	0.	0.	0.	4.82E-06	0.
RA223	7.69E-04	8.89E-07	1.54E-04	0.	2.36E-05	8.48E-02	3.00E-04
RA224	8.44E-05	1.53E-07	1.69E-05	0.	4.06E-06	2.92E-02	3.34E-04
RA225	1.28E-03	1.14E-06	2.56E-04	0.	3.02E-05	9.74E-02	2.84E-04
RA226	2.34E-01	7.66E-06	1.92E-01	0.	2.03E-04	3.90E-01	3.02E-04
RA228	1.49E-01	3.94E-06	1.68E-01	0.	1.04E-04	5.37E-01	5.14E-05
AC225	1.81E-03	1.87E-03	1.21E-04	0.	1.99E-04	7.37E-02	2.67E-04
AC227	4.96E+00	8.05E-01	3.07E-01	0.	1.77E-01	8.04E-01	5.22E-05
TH227	9.24E-04	1.26E-05	2.67E-05	0.	6.67E-05	1.26E-01	3.49E-04
TH228	8.06E-01	1.04E-02	2.72E-02	0.	5.41E-02	3.34E+00	3.59E-04
TH229	1.28E+01	1.76E-01	6.31E-01	0.	8.68E-01	1.04E+01	3.27E-04
TH230	3.30E+00	1.73E-01	9.20E-02	0.	8.52E-01	1.85E+00	3.84E-05
TH232	3.68E+00	1.47E-01	1.28E-01	0.	7.28E-01	1.77E+00	3.27E-05
TH234	6.94E-06	3.07E-07	2.00E-07	0.	1.62E-06	6.31E-04	7.32E-05
PA231	8.62E+00	2.86E-01	3.43E-01	0.	1.56E+00	1.92E-01	4.57E-05
PA233	4.14E-06	6.48E-07	7.25E-07	0.	2.38E-06	9.77E-05	8.95E-06
U232	2.19E-01	0.	1.56E-02	0.	1.67E-02	7.42E-01	4.33E-05
U233	4.64E-02	0.	2.82E-03	0.	7.62E-03	1.77E-01	4.00E-05
U234	4.46E-02	0.	2.76E-03	0.	7.47E-03	1.74E-01	3.92E-05
U235	4.27E-02	0.	2.59E-03	0.	7.01E-03	1.63E-01	4.98E-05
U236	4.27E-02	0.	2.65E-03	0.	7.16E-03	1.67E-01	3.67E-05
U237	1.57E-07	0.	4.17E-08	0.	4.53E-07	3.40E-05	1.29E-05
U238	4.09E-02	0.	2.42E-03	0.	6.55E-03	1.53E-01	3.51E-05
NP237	2.88E+00	2.21E-01	1.19E-01	0.	7.41E-01	1.74E-01	5.06E-05
NP238	1.26E-06	2.56E-08	1.97E-08	0.	8.16E-08	3.39E-05	2.50E-05
NP239	1.26E-07	9.04E-09	6.35E-09	0.	2.63E-08	1.57E-05	1.73E-05
PU238	4.77E+00	6.05E-01	1.21E-01	0.	4.47E-01	6.08E-01	4.65E-05
PU239	5.24E+00	6.44E-01	1.28E-01	0.	4.78E-01	5.72E-01	4.24E-05
PU240	5.23E+00	6.43E-01	1.27E-01	0.	4.77E-01	5.71E-01	4.33E-05
PU241	1.46E-01	6.33E-03	2.93E-03	0.	1.10E-02	5.06E-04	8.90E-07
PU242	4.85E+00	6.20E-01	1.23E-01	0.	4.60E-01	5.50E-01	4.16E-05
PU244	5.67E+00	7.10E-01	1.41E-01	0.	5.27E-01	6.30E-01	6.20E-05
AM241	1.74E+00	7.85E-01	1.24E-01	0.	7.63E-01	2.02E-01	4.73E-05
AM242M	1.79E+00	7.65E-01	1.27E-01	0.	7.71E-01	8.14E-02	5.96E-05
AM243	1.72E+00	7.53E-01	1.20E-01	0.	7.42E-01	1.92E-01	5.55E-05
CM242	6.33E-02	4.84E-02	4.20E-03	0.	1.34E-02	1.31E-01	5.06E-05
CM243	1.61E+00	7.33E-01	9.95E-02	0.	3.74E-01	2.10E-01	4.98E-05
CM244	1.33E+00	6.48E-01	8.31E-02	0.	3.06E-01	2.02E-01	4.82E-05
CM245	2.14E+00	8.16E-01	1.28E-01	0.	5.03E-01	1.95E-01	4.49E-05
CM246	2.13E+00	8.15E-01	1.28E-01	0.	5.03E-01	1.99E-01	4.41E-05
CM247	2.07E+00	8.02E-01	1.26E-01	0.	4.95E-01	1.95E-01	5.80E-05
CM248	1.72E+01	6.61E+00	1.04E+00	0.	4.08E+00	1.61E+00	9.35E-04
CF252	3.92E+00	0.	9.33E-02	0.	0.	6.62E-01	1.84E-04

INHALATION DOSE COMMITMENT FACTORS

TEEN INHALATION DOSE COMMITMENT FACTORS (MREM/50Y PER PCI INHALED IN FIRST YR)

ISOTOPE	BONE	LIVER	TOTAL BODY	THYROID	KIDNEY	LUNG	GI-LLI
H3*	0.	1.59E-07	1.59E-07	1.59E-07	1.59E-07	1.59E-07	1.59E-07
BE10	2.78E-04	4.33E-05	7.09E-06	0.	0.	3.84E-04	1.77E-05
C14	3.25E-06	6.09E-07	6.09E-07	6.09E-07	6.09E-07	6.09E-07	6.09E-07
N13	8.65E-09	8.65E-09	8.65E-09	8.65E-09	8.65E-09	8.65E-09	8.65E-09
F18	6.52E-07	0.	7.10E-08	0.	0.	0.	3.89E-08
NA22	1.76E-05	1.76E-05	1.76E-05	1.76E-05	1.76E-05	1.76E-05	1.76E-05
NA24	1.72E-06	1.72E-06	1.72E-06	1.72E-06	1.72E-06	1.72E-06	1.72E-06
P32	2.36E-04	1.37E-05	8.95E-06	0.	0.	0.	1.16E-05
AR39	0.	0.	0.	0.	0.	4.00E-09	0.
AR41	0.	0.	0.	0.	0.	1.44E-08	0.
CA41	4.05E-05	0.	4.38E-06	0.	0.	1.01E-01	3.03E-07
SC46	7.24E-05	1.41E-04	4.18E-05	0.	1.35E-04	0.	2.98E-05
CR51	0.	0.	1.69E-08	9.37E-09	3.84E-09	2.62E-06	3.75E-07
MN54	0.	6.39E-06	1.05E-06	0.	1.59E-06	2.48E-04	8.35E-06
MN56	0.	2.12E-10	3.15E-11	0.	2.24E-10	1.90E-06	7.18E-06
FE55	4.18E-06	2.98E-06	6.93E-07	0.	0.	1.55E-05	7.99E-07
FE59	1.99E-06	4.62E-06	1.79E-06	0.	0.	1.91E-04	2.23E-05
CO57	0.	1.18E-07	1.15E-07	0.	0.	7.33E-05	3.93E-06
CO58	0.	2.59E-07	3.47E-07	0.	0.	1.68E-04	1.19E-05
CO60	0.	1.89E-06	2.48E-06	0.	0.	1.09E-03	3.24E-05
NI59	5.44E-06	2.02E-06	9.24E-07	0.	0.	1.41E-05	6.48E-07
NI63	7.25E-05	5.43E-06	2.47E-06	0.	0.	3.84E-05	1.77E-06
NI65	2.73E-10	3.66E-11	1.59E-11	0.	0.	1.17E-06	4.59E-06
CU64	0.	2.54E-10	1.06E-10	0.	8.01E-10	1.39E-06	7.68E-06
ZN65	4.82E-06	1.67E-05	7.80E-06	0.	1.08E-05	1.55E-04	5.83E-06
ZN69M	1.44E-09	3.39E-09	3.11E-10	0.	2.06E-09	3.92E-06	2.14E-05
ZN69	6.04E-12	1.15E-11	8.07E-13	0.	7.53E-12	1.98E-07	3.56E-08
SE79	0.	5.43E-07	8.71E-08	0.	8.13E-07	7.71E-05	3.53E-06
BR82	0.	0.	2.28E-06	0.	0.	0.	0.
BR83	0.	0.	4.30E-08	0.	0.	0.	0.
BR84	0.	0.	5.41E-08	0.	0.	0.	0.
BR85	0.	0.	2.29E-09	0.	0.	0.	0.
KR83M	0.	0.	0.	0.	0.	9.97E-10	0.
KR85M	0.	0.	0.	0.	0.	5.46E-09	0.
KR85	0.	0.	0.	0.	0.	4.63E-09	0.
KR87	0.	0.	0.	0.	0.	2.82E-08	0.
KR88	0.	0.	0.	0.	0.	5.81E-08	0.
KR89	0.	0.	0.	0.	0.	3.85E-08	0.
RB86	0.	2.38E-05	1.05E-05	0.	0.	0.	2.21E-06
RB87	0.	1.40E-05	4.58E-06	0.	0.	0.	3.05E-07
RB88	0.	6.82E-08	3.40E-08	0.	0.	0.	3.65E-15
RB89	0.	4.40E-08	2.91E-08	0.	0.	0.	4.22E-17
SR89	5.43E-05	0.	1.56E-06	0.	0.	3.02E-04	4.64E-05
SR90	1.35E-02	0.	8.35E-04	0.	0.	2.06E-03	9.56E-05
SR91	1.10E-08	0.	4.39E-10	0.	0.	7.59E-06	3.24E-05
SR92	1.19E-09	0.	5.08E-11	0.	0.	3.43E-06	1.49E-05

*Includes a 50% increase to account for percutaneous transpiration.

INHALATION DOSE COMMITMENT FACTORS

TEEN INHALATION DOSE COMMITMENT FACTORS (MREM/50Y PER PCI INHALED IN FIRST YR)

ISOTOPE	BONE	LIVER	TOTAL BODY	THYROID	KIDNEY	LUNG	GI-LLI
Y90	3.73E-07	0.	1.00E-08	0.	0.	3.66E-05	6.99E-05
Y91M	4.63E-11	0.	1.77E-12	0.	0.	4.00E-07	3.77E-09
Y91	8.26E-05	0.	2.21E-06	0.	0.	3.67E-04	5.11E-05
Y92	1.84E-09	0.	5.36E-11	0.	0.	3.35E-06	2.06E-05
Y93	1.69E-08	0.	4.65E-10	0.	0.	1.04E-05	7.24E-05
ZR93	6.83E-05	3.38E-05	1.84E-05	0.	1.16E-04	3.67E-04	1.60E-05
ZR95	1.82E-05	5.73E-06	3.94E-06	0.	8.42E-06	3.36E-04	1.86E-05
ZR97	1.72E-08	3.40E-09	1.57E-09	0.	5.15E-09	1.62E-05	7.88E-05
NB93M	4.14E-05	1.36E-05	3.41E-06	0.	1.59E-05	5.36E-05	2.52E-06
NB95	2.32E-06	1.29E-06	7.08E-07	0.	1.25E-06	9.39E-05	1.21E-05
NB97	3.92E-11	9.72E-12	3.55E-12	0.	1.14E-11	4.91E-07	2.71E-07
MO93	0.	1.66E-06	4.52E-08	0.	5.06E-07	8.81E-05	3.99E-06
MO99	0.	2.11E-08	4.03E-09	0.	5.14E-08	1.92E-05	3.36E-05
TC99M	1.73E-13	4.83E-13	6.24E-12	0.	7.20E-12	1.44E-07	7.66E-07
TC99	4.48E-08	6.58E-08	1.79E-08	0.	8.35E-07	1.74E-04	7.99E-06
TC101	7.40E-15	1.05E-14	1.03E-13	0.	1.90E-13	8.34E-08	1.09E-16
RU103	2.63E-07	0.	1.12E-07	0.	9.29E-07	9.79E-05	1.36E-05
RU105	1.40E-10	0.	5.42E-11	0.	1.76E-10	2.27E-06	1.13E-05
RU106	1.23E-05	0.	1.55E-06	0.	2.38E-05	2.01E-03	1.20E-04
RH105	1.32E-09	9.48E-10	6.24E-10	0.	4.04E-09	4.09E-06	1.23E-05
PD107	0.	1.17E-07	8.39E-09	0.	9.39E-07	1.63E-05	7.49E-07
PD109	0.	6.56E-10	1.66E-10	0.	3.36E-09	3.19E-06	1.96E-05
AG110M	1.73E-06	1.64E-06	9.99E-07	0.	3.13E-06	8.44E-04	3.41E-05
AG111	6.07E-08	2.52E-08	1.26E-08	0.	8.17E-08	4.00E-05	3.00E-05
CD113M	0.	2.17E-04	7.10E-06	0.	2.43E-04	3.59E-04	1.68E-05
CD115M	0.	3.48E-05	1.14E-06	0.	2.82E-05	3.03E-04	5.10E-05
SN123	4.31E-05	9.44E-07	1.40E-06	7.55E-07	0.	4.96E-04	4.16E-05
SN125	1.66E-06	4.42E-08	9.99E-08	3.45E-08	0.	1.26E-04	7.29E-05
SN126	2.18E-04	5.39E-06	8.24E-06	1.42E-06	0.	1.72E-03	1.68E-05
SB124	5.38E-06	9.92E-08	2.10E-06	1.22E-08	0.	4.81E-04	4.98E-05
SB125	9.23E-06	1.01E-07	2.15E-06	8.80E-09	0.	3.42E-04	1.24E-05
SB126	6.19E-07	1.27E-08	2.23E-07	3.50E-09	0.	1.55E-04	6.01E-05
SB127	4.64E-08	9.92E-10	1.75E-08	5.21E-10	0.	3.31E-05	3.94E-05
TE125M	6.10E-07	2.80E-07	8.34E-08	1.75E-07	0.	6.70E-05	9.38E-06
TE127M	2.25E-06	1.02E-06	2.73E-07	5.48E-07	8.17E-06	2.07E-04	1.99E-05
TE127	2.51E-10	1.14E-10	5.52E-11	1.77E-10	9.10E-10	1.40E-06	1.01E-05
TE129M	1.74E-06	8.23E-07	2.81E-07	5.72E-07	6.49E-06	2.47E-04	5.06E-05
TE129	8.87E-12	4.22E-12	2.20E-12	6.48E-12	3.32E-11	4.12E-07	2.02E-07
TE131M	1.23E-08	7.51E-09	5.03E-09	9.06E-09	5.49E-08	2.97E-05	7.76E-05
TE131	1.97E-12	1.04E-12	6.30E-13	1.55E-12	7.72E-12	2.92E-07	1.89E-09
TE132	4.50E-08	3.63E-08	2.74E-08	3.07E-08	2.44E-07	5.61E-05	5.79E-05
TE133M	1.01E-11	7.33E-12	5.71E-12	8.18E-12	5.07E-11	8.71E-07	1.23E-07
TE134	5.31E-12	4.35E-12	3.64E-12	4.46E-12	2.91E-11	6.75E-07	1.37E-09
I129	3.53E-06	2.94E-06	4.90E-06	3.66E-03	5.26E-06	0.	2.29E-07
I130	7.80E-07	2.24E-06	8.96E-07	1.86E-04	3.44E-06	0.	1.14E-06
I131	4.43E-06	6.14E-06	3.30E-06	1.83E-03	1.05E-05	0.	8.11E-07

INHALATION DOSE COMMITMENT FACTORS

TEEN INHALATION DOSE COMMITMENT FACTORS (MREM/50Y PER PCI INHALED IN FIRST YR)

ISOTOPE	BONE	LIVER	TOTAL BODY	THYROID	KIDNEY	LUNG	GI-LLI
I132	1.99E-07	5.47E-07	1.97E-07	1.89E-05	8.65E-07	0.	1.59E-07
I133	1.52E-06	2.56E-06	7.78E-07	3.65E-04	4.49E-06	0.	1.29E-06
I134	1.11E-07	2.90E-07	1.05E-07	4.94E-06	4.58E-07	0.	2.55E-09
I135	4.62E-07	1.18E-06	4.36E-07	7.76E-05	1.86E-06	0.	8.69E-07
XE131M	0.	0.	0.	0.	0.	2.70E-09	0.
XE133M	0.	0.	0.	0.	0.	3.59E-09	0.
XE133	0.	0.	0.	0.	0.	2.99E-09	0.
XE135M	0.	0.	0.	0.	0.	3.88E-09	0.
XE135	0.	0.	0.	0.	0.	7.55E-09	0.
XE137	0.	0.	0.	0.	0.	3.33E-08	0.
XE138	0.	0.	0.	0.	0.	4.38E-08	0.
CS134M	2.20E-08	4.35E-08	2.35E-08	0.	2.54E-08	4.56E-09	2.02E-08
CS134	6.28E-05	1.41E-04	6.86E-05	0.	4.69E-05	1.83E-05	1.22E-06
CS135	2.08E-05	1.82E-05	4.47E-06	0.	7.30E-06	2.70E-06	2.23E-07
CS136	6.44E-06	2.42E-05	1.71E-05	0.	1.38E-05	2.22E-06	1.36E-06
CS137	8.38E-05	1.06E-04	3.89E-05	0.	3.80E-05	1.51E-05	1.06E-06
CS138	5.82E-08	1.07E-07	5.58E-08	0.	8.28E-08	9.84E-09	3.38E-11
CS139	3.65E-08	5.12E-08	1.97E-08	0.	4.34E-08	4.86E-09	1.66E-23
BA139	1.67E-10	1.18E-13	4.87E-12	0.	1.11E-13	8.08E-07	8.06E-07
BA140	6.84E-06	8.38E-09	4.40E-07	0.	2.85E-09	2.54E-04	2.86E-05
BA141	1.78E-11	1.32E-14	5.93E-13	0.	1.23E-14	4.11E-07	9.33E-14
BA142	4.62E-12	4.63E-15	2.84E-13	0.	3.92E-15	2.39E-07	5.99E-20
LA140	5.99E-08	2.95E-08	7.82E-09	0.	0.	2.68E-05	6.09E-05
LA141	7.63E-10	2.35E-10	3.87E-11	0.	0.	2.31E-06	1.54E-05
LA142	1.20E-10	5.31E-11	1.32E-11	0.	0.	1.27E-06	1.50E-06
CE141	3.55E-06	2.37E-06	2.71E-07	0.	1.11E-06	7.67E-05	1.58E-05
CE143	3.32E-08	2.42E-08	2.70E-09	0.	1.08E-08	1.63E-05	3.19E-05
CE144	6.11E-04	2.53E-04	3.28E-05	0.	1.51E-04	1.67E-03	1.08E-04
PR143	1.67E-06	6.64E-07	8.28E-08	0.	3.86E-07	6.04E-05	2.67E-05
PR144	5.37E-12	2.20E-12	2.72E-13	0.	1.26E-12	2.19E-07	2.94E-14
ND147	9.83E-07	1.07E-06	6.41E-08	0.	6.28E-07	4.65E-05	2.28E-05
PM147	1.15E-04	1.10E-05	4.50E-06	0.	2.10E-05	1.14E-04	5.87E-06
PM148M	1.32E-05	3.35E-06	2.62E-06	0.	5.07E-06	3.20E-04	4.10E-05
PM148	5.44E-07	8.88E-08	4.48E-08	0.	1.60E-07	6.52E-05	6.14E-05
PM149	4.91E-08	6.89E-09	2.84E-09	0.	1.31E-08	1.24E-05	2.79E-05
PM151	1.20E-08	1.99E-09	1.01E-09	0.	3.57E-09	6.56E-06	2.27E-05
SM151	1.07E-04	2.10E-05	4.86E-06	0.	2.27E-05	7.68E-05	3.53E-06
SM153	2.43E-08	2.01E-08	1.47E-09	0.	6.56E-09	7.11E-06	1.77E-05
EU152	2.96E-04	7.19E-05	6.30E-05	0.	3.34E-04	5.01E-04	1.35E-05
EU154	9.43E-04	1.23E-04	8.60E-05	0.	5.44E-04	9.12E-04	3.34E-05
EU155	2.00E-04	1.96E-05	1.21E-05	0.	7.65E-05	1.51E-03	5.97E-05
EU156	2.70E-06	2.03E-06	3.30E-07	0.	1.36E-06	1.37E-04	4.56E-05
TB160	3.04E-05	0.	3.79E-06	0.	1.20E-05	2.97E-04	2.60E-05
HO166M	4.40E-04	1.36E-04	9.87E-05	0.	2.00E-04	6.24E-04	1.68E-05
W181	8.90E-09	2.88E-09	3.01E-10	0.	0.	2.95E-06	2.69E-07
W185	2.78E-07	9.17E-08	9.73E-09	0.	0.	9.60E-05	1.14E-05
W187	1.50E-09	1.22E-09	4.29E-10	0.	0.	5.92E-06	2.21E-05

INHALATION DOSE COMMITMENT FACTORS

TEEN INHALATION DOSE COMMITMENT FACTORS (MREM/50Y PER PCI INHALED IN FIRST YR)

ISOTOPE	BONE	LIVER	TOTAL BODY	THYROID	KIDNEY	LUNG	GI-LLI
PB210	3.09E-02	8.28E-03	1.07E-03	0.	2.95E-02	4.52E-02	3.87E-05
BI210	0.	2.26E-06	1.89E-07	0.	2.74E-05	1.91E-03	3.19E-05
PO210	5.68E-04	1.22E-03	1.37E-04	0.	4.21E-03	5.41E-02	4.45E-05
RN222	0.	0.	0.	0.	0.	3.94E-06	0.
RA223	2.57E-04	3.93E-07	5.14E-05	0.	1.12E-05	4.39E-02	3.04E-04
RA224	2.83E-05	6.77E-08	5.65E-06	0.	1.93E-06	1.51E-02	3.29E-04
RA225	4.28E-04	5.04E-07	8.56E-05	0.	1.44E-05	5.04E-02	2.89E-04
RA226	1.33E-01	3.38E-06	9.87E-02	0.	9.67E-05	2.02E-01	3.11E-04
RA228	5.34E-02	1.74E-06	5.88E-02	0.	4.97E-05	2.78E-01	5.30E-05
AC225	6.04E-04	8.25E-04	4.06E-05	0.	9.47E-05	3.81E-02	2.70E-04
AC227	2.49E+00	3.69E-01	1.48E-01	0.	1.07E-01	4.16E-01	5.38E-05
TH227	3.09E-04	5.56E-06	8.93E-06	0.	3.18E-05	6.50E-02	3.57E-04
TH228	2.60E-01	4.37E-03	8.78E-03	0.	2.45E-02	1.69E+00	3.70E-04
TH229	9.06E+00	1.36E-01	4.45E-01	0.	6.67E-01	5.05E+00	3.36E-04
TH230	2.34E+00	1.34E-01	6.49E-02	0.	6.55E-01	8.98E-01	3.95E-05
TH232	2.61E+00	1.14E-01	9.21E-02	0.	5.60E-01	8.60E-01	3.36E-05
TH234	2.32E-06	1.35E-07	6.71E-08	0.	7.73E-07	3.26E-04	7.49E-05
PA231	5.32E+00	2.00E-01	2.07E-01	0.	1.12E+00	9.91E-02	4.71E-05
PA233	1.68E-06	3.24E-07	2.89E-07	0.	1.22E-06	5.39E-05	1.00E-05
U232	7.31E-02	0.	5.23E-03	0.	7.94E-03	3.84E-01	4.46E-05
U233	1.55E-02	0.	9.42E-04	0.	3.63E-03	9.18E-02	4.12E-05
U234	1.48E-02	0.	9.23E-04	0.	3.55E-03	8.99E-02	4.04E-05
U235	1.42E-02	0.	8.67E-04	0.	3.34E-03	8.44E-02	5.13E-05
U236	1.42E-02	0.	8.86E-04	0.	3.41E-03	8.62E-02	3.79E-05
U237	5.25E-08	0.	1.40E-08	0.	2.16E-07	1.76E-05	1.29E-05
U238	1.36E-02	0.	8.10E-04	0.	3.12E-03	7.89E-02	3.62E-05
NP237	1.77E+00	1.54E-01	7.21E-02	0.	5.35E-01	8.99E-02	5.22E-05
NP238	4.23E-07	1.13E-08	6.59E-09	0.	3.88E-08	1.75E-05	2.38E-05
NP239	4.23E-08	3.99E-09	2.21E-09	0.	1.25E-08	8.11E-06	1.65E-05
PU238	2.86E+00	4.06E-01	7.22E-02	0.	3.10E-01	3.12E-01	4.79E-05
PU239	3.31E+00	4.50E-01	8.05E-02	0.	3.44E-01	2.93E-01	4.37E-05
PU240	3.31E+00	4.49E-01	8.04E-02	0.	3.43E-01	2.93E-01	4.46E-05
PU241	6.97E-02	3.57E-03	1.40E-03	0.	6.47E-03	2.60E-04	9.17E-07
PU242	3.07E+00	4.33E-01	7.75E-02	0.	3.31E-01	2.82E-01	4.29E-05
PU244	3.59E+00	4.96E-01	8.88E-02	0.	3.79E-01	3.23E-01	6.39E-05
AM241	1.06E+00	4.07E-01	7.10E-02	0.	5.32E-01	1.05E-01	4.88E-05
AM242M	1.07E+00	3.93E-01	7.15E-02	0.	5.30E-01	4.21E-02	6.14E-05
AM243	1.06E+00	3.92E-01	6.95E-02	0.	5.21E-01	9.91E-02	5.72E-05
CM242	2.12E-02	2.14E-02	1.41E-03	0.	6.40E-03	6.76E-02	5.21E-05
CM243	8.45E-01	3.50E-01	5.00E-02	0.	2.34E-01	1.09E-01	5.13E-05
CM244	6.46E-01	3.03E-01	3.88E-02	0.	1.81E-01	1.05E-01	4.96E-05
CM245	1.32E+00	4.11E-01	7.53E-02	0.	3.52E-01	1.01E-01	4.63E-05
CM246	1.31E+00	4.11E-01	7.52E-02	0.	3.51E-01	1.03E-01	4.54E-05
CM247	1.28E+00	4.04E-01	7.41E-02	0.	3.46E-01	1.01E-01	5.97E-05
CM248	1.06E+01	3.33E+00	6.11E-01	0.	2.85E+00	8.32E-01	9.63E-04
CF252	1.29E+00	0.	3.07E-02	0.	0.	3.43E-01	1.89E-04

INHALATION DOSE COMMITMENT FACTORS

ADULT INHALATION DOSE COMMITMENT FACTORS (MREM/50Y PER PCI INHALED IN FIRST YR)

ISOTOPE	BONE	LIVER	TOTAL BODY	THYROID	KIDNEY	LUNG	GI-LLI
H3*	0.	1.58E-07	1.58E-07	1.58E-07	1.58E-07	1.58E-07	1.58E-07
BE10	1.98E-04	3.06E-05	4.96E-06	0.	0.	2.22E-04	1.67E-05
C14	2.27E-06	4.26E-07	4.26E-07	4.26E-07	4.26E-07	4.26E-07	4.26E-07
N13	6.27E-09	6.27E-09	6.27E-09	6.27E-09	6.27E-09	6.27E-09	6.27E-09
F18	4.71E-07	0.	5.19E-08	0.	0.	0.	9.24E-09
NA22	1.30E-05	1.30E-05	1.30E-05	1.30E-05	1.30E-05	1.30E-05	1.30E-05
NA24	1.28E-06	1.28E-06	1.28E-06	1.28E-06	1.28E-06	1.28E-06	1.28E-06
P32	1.65E-04	9.64E-06	6.26E-06	0.	0.	0.	1.08E-05
AR39	0.	0.	0.	0.	0.	2.08E-09	0.
AR41	0.	0.	0.	0.	0.	8.06E-09	0.
CA41	3.83E-05	0.	4.13E-06	0.	0.	3.83E-06	2.86E-07
SC46	5.51E-05	1.07E-04	3.11E-05	0.	9.99E-05	0.	3.23E-05
CR51	0.	0.	1.25E-08	7.44E-09	2.85E-09	1.80E-06	4.15E-07
MN54	0.	4.95E-06	7.87E-07	0.	1.23E-06	1.75E-04	9.67E-06
MN56	0.	1.55E-10	2.29E-11	0.	1.63E-10	1.18E-06	2.53E-06
FE55	3.07E-06	2.12E-06	4.93E-07	0.	0.	9.01E-06	7.54E-07
FE59	1.47E-06	3.47E-06	1.32E-06	0.	0.	1.27E-04	2.35E-05
CO57	0.	8.65E-08	8.39E-08	0.	0.	4.62E-05	3.93E-06
CO58	0.	1.98E-07	2.59E-07	0.	0.	1.16E-04	1.33E-05
CO60	0.	1.44E-06	1.85E-06	0.	0.	7.46E-04	3.56E-05
NI59	4.06E-06	1.46E-06	6.77E-07	0.	0.	8.20E-06	6.11E-07
NI63	5.40E-05	3.93E-06	1.81E-06	0.	0.	2.23E-05	1.67E-06
NI65	1.92E-10	2.62E-11	1.14E-11	0.	0.	7.00E-07	1.54E-06
CU64	0.	1.83E-10	7.69E-11	0.	5.78E-10	8.48E-07	6.12E-06
ZN65	4.05E-06	1.29E-05	5.82E-06	0.	8.62E-06	1.08E-04	6.68E-06
ZN69M	1.02E-09	2.45E-09	2.24E-10	0.	1.48E-09	2.38E-06	1.71E-05
ZN69	4.23E-12	8.14E-12	5.65E-13	0.	5.27E-12	1.15E-07	2.04E-09
SE79	0.	3.83E-07	6.09E-08	0.	5.69E-07	4.47E-05	3.33E-06
BR82	0.	0.	1.69E-06	0.	0.	0.	1.30E-06
BR83	0.	0.	3.01E-08	0.	0.	0.	2.90E-08
BR84	0.	0.	3.91E-08	0.	0.	0.	2.05E-13
BR85	0.	0.	1.60E-09	0.	0.	0.	0.
KR83M	0.	0.	0.	0.	0.	5.19E-10	0.
KR85M	0.	0.	0.	0.	0.	2.91E-09	0.
KR85	0.	0.	0.	0.	0.	2.41E-09	0.
KR87	0.	0.	0.	0.	0.	1.53E-08	0.
KR88	0.	0.	0.	0.	0.	3.13E-08	0.
KR89	0.	0.	0.	0.	0.	2.13E-08	0.
RB86	0.	1.69E-05	7.37E-06	0.	0.	0.	2.08E-06
RB87	0.	9.86E-06	3.21E-06	0.	0.	0.	2.88E-07
RB88	0.	4.84E-08	2.41E-08	0.	0.	0.	4.18E-19
RB89	0.	3.20E-08	2.12E-08	0.	0.	0.	1.16E-21
SR89	3.80E-05	0.	1.09E-06	0.	0.	1.75E-04	4.37E-05
SR90	1.24E-02	0.	7.62E-04	0.	0.	1.20E-03	9.02E-05
SR91	7.74E-09	0.	3.13E-10	0.	0.	4.56E-06	2.39E-05
SR92	8.43E-10	0.	3.64E-11	0.	0.	2.06E-06	5.38E-06

*Includes a 50% increase to account for percutaneous transpiration.

INHALATION DOSE COMMITMENT FACTORS

ADULT INHALATION DOSE COMMITMENT FACTORS (MREM/50Y PER PCI INHALED IN FIRST YR)

ISOTOPE	BONE	LIVER	TOTAL BODY	THYROID	KIDNEY	LUNG	GI-LLI
Y90	2.61E-07	0.	7.01E-09	0.	0.	2.12E-05	6.32E-05
Y91M	3.26E-11	0.	1.27E-12	0.	0.	2.40E-07	1.66E-10
Y91	5.78E-05	0.	1.55E-06	0.	0.	2.13E-04	4.81E-05
Y92	1.29E-09	0.	3.77E-11	0.	0.	1.96E-06	9.19E-06
Y93	1.18E-08	0.	3.26E-10	0.	0.	6.06E-06	5.27E-05
ZR93	5.22E-05	2.92E-06	1.37E-06	0.	1.11E-05	2.13E-05	1.51E-06
ZR95	1.34E-05	4.30E-06	2.91E-06	0.	6.77E-06	2.21E-04	1.88E-05
ZR97	1.21E-08	2.45E-09	1.13E-09	0.	3.71E-09	9.84E-06	6.54E-05
NB93M	3.10E-05	1.01E-05	2.49E-06	0.	1.16E-05	3.11E-05	2.38E-06
NB95	1.76E-06	9.77E-07	5.26E-07	0.	9.67E-07	6.31E-05	1.30E-05
NB97	2.78E-11	7.03E-12	2.56E-12	0.	8.18E-12	3.00E-07	3.02E-08
MO93	0.	1.17E-06	3.17E-08	0.	3.55E-07	5.11E-05	3.79E-06
MO99	0.	1.51E-08	2.87E-09	0.	3.64E-08	1.14E-05	3.10E-05
TC99M	1.29E-13	3.64E-13	4.63E-12	0.	5.52E-12	9.55E-08	5.20E-07
TC99	3.13E-08	4.64E-08	1.25E-08	0.	5.85E-07	1.01E-04	7.54E-06
TC101	5.22E-15	7.52E-15	7.38E-14	0.	1.35E-13	4.99E-08	1.36E-21
RU103	1.91E-07	0.	8.23E-08	0.	7.29E-07	6.31E-05	1.38E-05
RU105	9.88E-11	0.	3.89E-11	0.	1.27E-10	1.37E-06	6.02E-06
RU106	8.64E-06	0.	1.09E-06	0.	1.67E-05	1.17E-03	1.14E-04
RH105	9.24E-10	6.73E-10	4.43E-10	0.	2.86E-09	2.41E-06	1.09E-05
PD107	0.	8.27E-08	5.87E-09	0.	6.57E-07	9.47E-06	7.06E-07
PD109	0.	4.63E-10	1.16E-10	0.	2.35E-09	1.85E-06	1.52E-05
AG110M	1.35E-06	1.25E-06	7.43E-07	0.	2.46E-06	5.79E-04	3.78E-05
AG111	4.25E-08	1.78E-08	8.87E-09	0.	5.74E-08	2.33E-05	2.79E-05
CD113M	0.	1.54E-04	4.97E-06	0.	1.71E-04	2.08E-04	1.59E-05
CD115M	0.	2.46E-05	7.95E-07	0.	1.98E-05	1.76E-04	4.80E-05
SN123	3.02E-05	6.67E-07	9.82E-07	5.67E-07	0.	2.88E-04	3.92E-05
SN125	1.16E-06	3.12E-08	7.03E-08	2.59E-08	0.	7.37E-05	6.81E-05
SN126	1.58E-04	4.18E-06	6.00E-06	1.23E-06	0.	1.17E-03	1.59E-05
SB124	3.90E-06	7.36E-08	1.55E-06	9.44E-09	0.	3.10E-04	5.08E-05
SB125	6.67E-06	7.44E-08	1.58E-06	6.75E-09	0.	2.18E-04	1.26E-05
SB126	4.50E-07	9.13E-09	1.62E-07	2.75E-09	0.	9.57E-05	6.01E-05
SB127	3.30E-08	7.22E-10	1.27E-08	3.97E-10	0.	2.05E-05	3.77E-05
TE125M	4.27E-07	1.98E-07	5.84E-08	1.31E-07	1.55E-06	3.92E-05	8.83E-06
TE127M	1.58E-06	7.21E-07	1.96E-07	4.11E-07	5.72E-06	1.20E-04	1.87E-05
TE127	1.75E-10	8.03E-11	3.87E-11	1.32E-10	6.37E-10	8.14E-07	7.17E-06
TE129M	1.22E-06	5.84E-07	1.98E-07	4.30E-07	4.57E-06	1.45E-04	4.79E-05
TE129	6.22E-12	2.99E-12	1.55E-12	4.87E-12	2.34E-11	2.42E-07	1.96E-08
TE131M	8.74E-09	5.45E-09	3.63E-09	6.88E-09	3.86E-08	1.82E-05	6.95E-05
TE131	1.39E-12	7.44E-13	4.49E-13	1.17E-12	5.46E-12	1.74E-07	2.30E-09
TE132	3.25E-08	2.69E-08	2.02E-08	2.37E-08	1.82E-07	3.60E-05	6.37E-05
TE133M	7.24E-12	5.40E-12	4.17E-12	6.27E-12	3.74E-11	5.51E-07	5.49E-08
TE134	3.84E-12	3.22E-12	1.57E-12	3.44E-12	2.18E-11	4.343E-07	2.97E-11
I129	2.48E-06	2.11E-06	6.91E-06	5.54E-03	4.53E-06	0.	2.22E-07
I130	5.72E-07	1.68E-06	6.60E-07	1.42E-04	2.61E-06	0.	9.61E-07
I131	3.15E-06	4.47E-06	2.56E-06	1.49E-03	7.66E-06	0.	7.85E-07

INHALATION DOSE COMMITMENT FACTORS

ADULT INHALATION DOSE COMMITMENT FACTORS (MREM/50Y PER PCI INHALED IN FIRST YR)

ISOTOPE	BONE	LIVER	TOTAL BODY	THYROID	KIDNEY	LUNG	GI-LLI
I132	1.45E-07	4.07E-07	1.45E-07	1.43E-05	6.48E-07	0.	5.08E-08
I133	1.08E-06	1.85E-06	5.65E-07	2.69E-04	3.23E-06	0.	1.11E-06
I134	8.05E-08	2.16E-07	7.69E-08	3.73E-06	3.44E-07	0.	1.26E-10
I135	3.35E-07	8.73E-07	3.21E-07	5.60E-05	1.39E-06	0.	6.56E-07
XE131M	0.	0.	0.	0.	0.	1.40E-09	0.
XE133M	0.	0.	0.	0.	0.	1.89E-09	0.
XE133	0.	0.	0.	0.	0.	1.57E-09	0.
XE135M	0.	0.	0.	0.	0.	2.22E-09	0.
XE135	0.	0.	0.	0.	0.	4.05E-09	0.
XE137	0.	0.	0.	0.	0.	1.74E-08	0.
XE138	0.	0.	0.	0.	0.	2.44E-08	0.
CS134M	1.59E-08	3.20E-08	1.72E-08	0.	1.83E-08	2.93E-09	7.92E-09
CS134	4.66E-05	1.06E-04	9.10E-05	0.	3.59E-05	1.22E-05	1.30E-06
CS135	1.46E-05	1.29E-05	5.99E-06	0.	5.11E-06	1.57E-06	2.11E-07
CS136	4.88E-06	1.83E-05	1.38E-05	0.	1.07E-05	1.50E-06	1.46E-06
CS137	5.98E-05	7.76E-05	5.35E-05	0.	2.78E-05	9.40E-06	1.05E-06
CS138	4.14E-08	7.76E-08	4.05E-08	0.	6.00E-08	6.07E-09	2.33E-13
CS139	2.56E-08	3.63E-08	1.39E-08	0.	3.05E-08	2.84E-09	5.49E-31
BA139	1.17E-10	8.32E-14	3.42E-12	0.	7.78E-14	4.70E-07	1.12E-07
BA140	4.88E-06	6.13E-09	3.21E-07	0.	2.09E-09	1.59E-04	2.73E-05
BA141	1.25E-11	9.41E-15	4.20E-13	0.	8.75E-15	2.42E-07	1.45E-17
BA142	3.29E-12	3.38E-15	2.07E-13	0.	2.86E-15	1.49E-07	1.96E-26
LA140	4.30E-08	2.17E-08	5.73E-09	0.	0.	1.70E-05	5.73E-05
LA141	5.34E-10	1.66E-10	2.71E-11	0.	0.	1.35E-06	7.31E-06
LA142	8.54E-11	3.88E-11	9.65E-12	0.	0.	7.91E-07	2.64E-07
CE141	2.49E-06	1.69E-06	1.91E-07	0.	7.83E-07	4.52E-05	1.50E-05
CE143	2.33E-08	1.72E-08	1.91E-09	0.	7.60E-09	9.97E-06	2.83E-05
CE144	4.29E-04	1.79E-04	2.30E-05	0.	1.06E-04	9.72E-04	1.02E-04
PR143	1.17E-06	4.69E-07	5.80E-08	0.	2.70E-07	3.51E-05	2.50E-05
PR144	3.76E-12	1.56E-12	1.91E-13	0.	8.81E-13	1.27E-07	2.69E-18
ND147	6.59E-07	7.62E-07	4.56E-08	0.	4.45E-07	2.76E-05	2.16E-05
PM147	8.37E-05	7.87E-06	3.19E-06	0.	1.49E-05	6.60E-05	5.54E-06
PM148M	9.82E-06	2.54E-06	1.94E-06	0.	3.85E-06	2.14E-04	4.18E-05
PM148	3.84E-07	6.37E-08	3.20E-08	0.	1.20E-07	3.91E-05	5.80E-05
PM149	3.44E-08	4.87E-09	1.99E-09	0.	9.19E-09	7.21E-06	2.50E-05
PM151	8.50E-09	1.42E-09	7.21E-10	0.	2.55E-09	3.94E-06	2.00E-05
SM151	8.59E-05	1.48E-05	3.55E-06	0.	1.66E-05	4.45E-05	3.25E-06
SM153	1.70E-08	1.42E-08	1.04E-09	0.	4.59E-09	4.14E-06	1.58E-05
EU152	2.38E-04	5.41E-05	4.76E-05	0.	3.35E-04	3.43E-04	1.59E-05
EU154	7.40E-04	9.10E-05	6.48E-05	0.	4.36E-04	5.84E-04	3.40E-05
EU155	1.01E-04	1.43E-05	9.21E-06	0.	6.59E-05	9.46E-05	5.95E-06
EU156	1.93E-06	1.48E-06	2.40E-07	0.	9.95E-07	8.56E-05	4.50E-05
TB160	2.21E-05	0.	2.75E-06	0.	9.10E-06	1.92E-04	2.68E-05
HO166M	3.37E-04	1.05E-04	8.00E-05	0.	1.57E-04	3.94E-04	1.59E-05
W181	6.23E-09	2.03E-09	2.17E-10	0.	0.	1.71E-06	2.53E-07
W185	1.95E-07	6.47E-08	6.81E-09	0.	0.	5.57E-05	1.07E-05
W187	1.06E-09	8.85E-10	3.10E-10	0.	0.	3.63E-06	1.94E-05

INHALATION DOSE COMMITMENT FACTORS

ADULT INHALATION DOSE COMMITMENT FACTORS (MREM/50Y PER PCI INHALED IN FIRST YR)

ISOTOPE	BONE	LIVER	TOTAL BODY	THYROID	KIDNEY	LUNG	GI-LLI
PB210	2.64E-02	6.73E-03	8.37E-04	0.	2.12E-02	2.62E-02	3.65E-05
BI210	0.	1.59E-06	1.32E-07	0.	1.92E-05	1.11E-03	2.95E-05
PO210	3.97E-04	8.60E-04	9.58E-05	0.	2.95E-03	3.14E-02	4.19E-05
RN222	0.	0.	0.	0.	0.	2.05E-06	0.
RA223	1.80E-04	2.77E-07	3.60E-05	0.	7.85E-06	2.55E-02	2.84E-04
RA224	1.98E-05	4.78E-08	3.96E-06	0.	1.35E-06	8.77E-03	3.01E-04
RA225	3.00E-04	3.56E-07	5.99E-05	0.	1.01E-05	2.92E-02	2.71E-04
RA226	1.25E-01	2.39E-06	9.14E-02	0.	6.77E-05	1.17E-01	2.94E-04
RA228	4.41E-02	1.23E-06	4.78E-02	0.	3.48E-05	1.61E-01	5.00E-05
AC225	4.23E-04	5.82E-04	2.84E-05	0.	6.63E-05	2.21E-02	2.52E-04
AC227	2.30E+00	3.05E-01	1.36E-01	0.	9.82E-02	2.41E-01	5.08E-05
TH227	2.17E-04	3.92E-06	6.25E-06	0.	2.22E-05	3.77E-02	3.34E-04
TH226	2.00E-01	3.39E-03	6.77E-03	0.	1.89E-02	1.01E+00	3.49E-04
TH229	8.88E+00	1.33E-01	4.36E-01	0.	6.52E-01	3.49E+00	3.17E-04
TH230	2.29E+00	1.31E-01	6.36E-02	0.	6.40E-01	6.21E-01	3.73E-05
TH232	2.56E+00	1.12E-01	9.04E-02	0.	5.47E-01	5.96E-01	3.17E-05
TH234	1.63E-06	9.56E-08	4.70E-08	0.	5.41E-07	1.89E-04	7.03E-05
PA231	5.08E+00	1.91E-01	1.98E-01	0.	1.07E+00	5.75E-02	4.44E-05
PA233	1.21E-06	2.42E-07	2.09E-07	0.	9.15E-07	3.52E-05	1.02E-05
U232	5.14E-02	0.	3.66E-03	0.	5.56E-03	2.22E-01	4.21E-05
U233	1.09E-02	0.	6.60E-04	0.	2.54E-03	5.32E-02	3.89E-05
U234	1.04E-02	0.	6.46E-04	0.	2.49E-03	5.22E-02	3.81E-05
U235	1.00E-02	0.	6.07E-04	0.	2.34E-03	4.90E-02	4.84E-05
U236	1.00E-02	0.	6.20E-04	0.	2.39E-03	5.00E-02	3.57E-05
U237	3.67E-08	0.	9.77E-09	0.	1.51E-07	1.02E-05	1.20E-05
U238	9.58E-03	0.	5.67E-04	0.	2.18E-03	4.58E-02	3.41E-05
NP237	1.69E+00	1.47E-01	6.87E-02	0.	5.10E-01	5.22E-02	4.92E-05
NP238	2.96E-07	8.00E-09	4.61E-09	0.	2.72E-08	1.02E-05	2.13E-05
NP239	2.87E-08	2.82E-09	1.55E-09	0.	8.75E-09	4.70E-06	1.49E-05
PU238	2.74E+00	3.87E-01	6.90E-02	0.	2.96E-01	1.82E-01	4.52E-05
PU239	3.19E+00	4.31E-01	7.75E-02	0.	3.30E-01	1.72E-01	4.13E-05
PU240	3.18E+00	4.30E-01	7.73E-02	0.	3.29E-01	1.72E-01	4.21E-05
PU241	6.41E-02	3.28E-03	1.29E-03	0.	5.93E-03	1.52E-04	8.65E-07
PU242	2.95E+00	4.15E-01	7.46E-02	0.	3.17E-01	1.65E-01	4.05E-05
PU244	3.45E+00	4.76E-01	8.54E-02	0.	3.64E-01	1.89E-01	6.03E-05
AM241	1.01E+00	3.59E-01	6.71E-02	0.	5.04E-01	6.06E-02	4.60E-05
AM242M	1.02E+00	3.46E-01	6.73E-02	0.	5.01E-01	2.44E-02	5.79E-05
AM243	1.01E+00	3.47E-01	6.57E-02	0.	4.95E-01	5.75E-02	5.40E-05
CM242	1.48E-02	1.51E-02	9.84E-04	0.	4.48E-03	3.92E-02	4.91E-05
CM243	7.86E-01	2.97E-01	4.61E-02	0.	2.15E-01	6.31E-02	4.84E-05
CM244	5.90E-01	2.54E-01	3.51E-02	0.	1.64E-01	6.06E-02	4.68E-05
CM245	1.26E+00	3.59E-01	7.14E-02	0.	3.33E-01	5.85E-02	4.36E-05
CM246	1.25E+00	3.59E-01	7.13E-02	0.	3.33E-01	5.96E-02	4.29E-05
CM247	1.22E+00	3.53E-01	7.03E-02	0.	3.28E-01	5.85E-02	5.63E-05
CM248	1.01E+01	2.91E+00	5.79E-01	0.	2.70E+00	4.82E-01	9.09E-04
CF252	9.78E-01	0.	2.33E-02	0.	0.	1.99E-01	1.78E-04

EXTERNAL DOSE FACTORS FOR STANDING ON CONTAMINATED GROUND (DFG)
(mrem/hr per pCi/m²)

ELEMENT	TOTAL BODY	SKIN
H-3	0.0	0.0
C-14	0.0	0.0
Na-24	2.50E-08	2.90E-08
P-32	0.0	0.0
Cr-51	2.20E-10	2.60E-10
Mn-54	5.80E-09	6.80E-09
Mn-56	1.10E-08	1.30E-08
Fe-55	0.0	0.0
Fe-59	8.00E-09	9.40E-09
Co-58	7.00E-09	8.20E-09
Co-60	1.70E-08	2.00E-08
Ni-63	0.0	0.0
Ni-65	3.70E-09	4.30E-09
Cu-64	1.50E-09	1.70E-09
Zn-65	4.00E-09	4.60E-09
Zn-69	0.0	0.0
Br-83	6.40E-11	9.30E-11
Br-84	1.20E-08	1.40E-08
Br-85	0.0	0.0
Rb-86	6.30E-10	7.20E-10
Rb-88	3.50E-09	4.00E-09
Rb-89	1.50E-08	1.80E-08
Sr-89	5.60E-13	6.50E-13
Sr-91	7.10E-09	8.30E-09
Sr-92	9.00E-09	1.00E-08
Y-90	2.20E-12	2.60E-12
Y-91m	3.80E-09	4.40E-09
Y-91	2.40E-11	2.70E-11
Y-92	1.60E-09	1.90E-09
Y-93	5.70E-10	7.80E-10
Zr-95	5.00E-09	5.80E-09
Zr-97	5.50E-09	6.40E-09
Nb-95	5.10E-09	6.00E-09
Mo-99	1.90E-09	2.20E-09
Tc-99m	9.60E-10	1.10E-09
Tc-101	2.70E-09	3.00E-09

EXTERNAL DOSE FACTORS FOR STANDING ON CONTAMINATED GROUND (DFG)
(mrem/hr per pCi/m²)

ELEMENT	TOTAL BODY	SKIN
Ru-103	3.60E-09	4.20E-09
Ru-105	4.50E-09	5.10E-09
Ru-106	1.50E-09	1.80E-09
Ag-110m	1.80E-08	2.10E-08
Te-125m	3.50E-11	4.80E-11
Te-127m	1.10E-12	1.30E-12
Te-127	1.00E-11	1.10E-11
Te-129m	7.70E-10	9.00E-10
Te-129	7.10E-10	8.40E-10
Te-131m	8.40E-09	9.90E-09
Te-131	2.20E-09	2.60E-06
Te-132	1.70E-09	2.00E-09
I-130	1.40E-08	1.70E-08
I-131	2.80E-09	3.40E-09
I-132	1.70E-08	2.00E-08
I-133	3.70E-09	4.50E-09
I-134	1.60E-08	1.90E-08
I-135	1.20E-08	1.40E-08
Cs-134	1.20E-08	1.40E-08
Cs-136	1.50E-08	1.70E-08
Cs-137	4.20E-09	4.90E-09
Cs-138	2.10E-08	2.40E-08
Ba-139	2.40E-09	2.70E-09
Ba-140	2.10E-09	2.40E-09
Ba-141	4.30E-09	4.90E-09
Ba-142	7.90E-09	9.00E-09
La-140	1.50E-08	1.70E-08
La-142	1.50E-08	1.80E-08
Ce-141	5.50E-10	6.20E-10
Ce-143	2.20E-09	2.50E-09
Ce-144	3.20E-10	3.70E-10
Pr-143	0.0	0.0
Pr-144	2.00E-10	2.30E-10
Nd-147	1.00E-09	1.20E-09
W-187	3.10E-09	3.60E-09
Np-239	9.50E-10	1.10E-09

BIOACCUMULATION FACTORS
μCi/gm per μCi/ml

<u>ELEMENT</u>	<u>FRESHWATER FISH</u>
H	9.0E-01
C	4.6E 03
NA	1.0E 02
P	1.0E 05
CR	2.0E 02
MN	4.0E 02
FE	1.0E 02
CO	5.0E 01
NI	1.0E 02
CU	5.0E 01
ZN	2.0E 03
BR	4.2E 02
RB	2.0E 03
SR	3.0E 01
Y	2.5E 01
ZR	3.3E 00
NB	3.0E 04
MO	1.0E 01
TC	1.5E 01
RU	1.0E 01
RH	1.0E 01
TE	4.0E 02
I	1.5E 01
CS	2.0E 03
BA	4.0E 00
LA	2.5E 01
CE	1.0E 00
PR	2.5E 01
ND	2.5E 01
W	1.2E 03
NP	1.0E 01

INGESTION DOSE COMMITMENT FACTORS

INFANT INGESTION DOSE COMMITMENT FACTORS (MREM/50Y PER PCI INGESTED IN FIRST YR)

ISOTOPE	BONE	LIVER	TOTAL BODY	THYROID	KIDNEY	LUNG	GI-LLI
H3	0.	3.08E-07	3.08E-07	3.08E-07	3.08E-07	3.08E-07	3.083-07
BE10	1.71E-05	2.49E-06	5.16E-07	0.	1.64E-06	0.	2.78E-05
C14	2.37E-05	5.06E-06	5.06E-06	5.06E-06	5.06E-06	5.06E-06	5.06E-06
N13	5.85E-08	5.85E-08	5.85E-08	5.835E-08	5.85E-08	5.85E-08	5.85E-08
F18	5.19E-06	0.	4.43E-07	0.	0.	0.	1.22E-06
NA22	9.83E-05	9.83E-05	9.83E-05	9.83E-05	9.83E-05	9.83E-05	9.83E-05
NA24	1.01E-05	1.01E-05	1.01E-05	1.01E-05	1.01E-05	1.01E-05	1.01E-05
P32	1.70E-03	1.00E-04	6.59E-05	0.	0.	0.	2.30E-05
AR39	0.	0.	0.	0.	0.	0.	0.
AR41	0.	0.	0.	0.	0.	0.	0.
CA41	3.74E-04	0.	4.08E-05	0.	0.	0.	1.91E-07
SC46	3.75E-08	5.41E-08	1.69E-08	0.	3.56E-08	0.	3.53E-05
CR51	0.	0.	1.41E-08	9.20E-09	2.01E-09	1.79E-08	4.11E-07
MN54	0.	1.99E-05	4.51E-06	0.	4.41E-06	0.	7.31E-06
MN56	0.	8.18E-07	1.41E-07	0.	7.03E-07	0.	7.43E-05
FE55	1.39E-05	8.98E-06	2.40E-06	0.	0.	4.39E-06	1.14E-06
FE59	3.08E-05	5.38E-05	2.12E-05	0.	0.	1.59E-05	2.57E-05
CO57	0.	1.15E-06	1.87E-06	0.	0.	0.	3.92E-06
CO58	0.	3.60E-06	8.98E-06	0.	0.	0.	8.97E-06
CO60	0.	1.08E-05	2.55E-05	0.	0.	0.	2.57E-05
NI59	4.78E-05	1.45E-05	8.17E-06	0.	0.	0.	7.16E-07
NI63	6.34E-04	3.92E-05	2.20E-05	0.	0.	0.	1.95E-06
NI65	4.70E-06	5.32E-07	2.42E-07	0.	0.	0.	4.05E-05
CU64	0.	6.09E-07	2.82E-07	0.	1.03E-06	0.	1.25E-05
ZN65	1.84E-05	6.31E-05	2.91E-05	0.	3.06E-05	0.	5.33E-05
ZN69M	1.50E-06	3.06E-06	2.79E-07	0.	1.24E-06	0.	4.24E-05
ZN69	9.33E-08	1.68E-07	1.25E-08	0.	6.98E-08	0.	1.37E-05
SE79	0.	2.10E-05	3.90E-06	0.	2.43E-05	0.	5.58E-07
BR82	0.	0.	1.27E-05	0.	0.	0.	0.
BR83	0.	0.	3.63E-07	0.	0.	0.	0.
BR84	0.	0.	3.82E-07	0.	0.	0.	0.
BR85	0.	0.	1.94E-08	0.	0.	0.	0.
KR83M	0.	0.	0.	0.	0.	0.	0.
KR85M	0.	0.	0.	0.	0.	0.	0.
KR85	0.	0.	0.	0.	0.	0.	0.
KR87	0.	0.	0.	0.	0.	0.	0.
KR88	0.	0.	0.	0.	0.	0.	0.
KR89	0.	0.	0.	0.	0.	0.	0.
RB86	0.	1.70E-04	8.40E-05	0.	0.	0.	4.35E-06
RB87	0.	8.88E-05	3.52E-05	0.	0.	0.	5.98E-07
RB88	0.	4.98E-07	2.73E-07	0.	0.	0.	4.85E-07
RB89	0.	2.86E-07	1.97E-07	0.	0.	0.	9.74E-08
SR89	2.51E-03	0.	7.20E-05	0.	0.	0.	5.16E-05
SR90	1.85E-02	0.	4.71E-03	0.	0.	0.	2.31E-04
SR91	5.00E-05	0.	1.81E-06	0.	0.	0.	5.92E-05
SR92	1.92E-05	0.	7.13E-07	0.	0.	0.	2.07E-04

INGESTION DOSE COMMITMENT FACTORS

INFANT INGESTION DOSE COMMITMENT FACTORS (MREM/50Y PER PCI INGESTED IN FIRST YR)

ISOTOPE	BONE	LIVER	TOTAL BODY	THYROID	KIDNEY	LUNG	GI-LI
Y90	8.69E-08	0.	2.33E-09	0.	0.	0.	1.20E-04
Y91M	8.10E-10	0.	2.76E-11	0.	0.	0.	2.70E-06
Y91	1.13E-06	0.	3.01E-08	0.	0.	0.	8.10E-05
Y92	7.65E-09	0.	2.15E-10	0.	0.	0.	1.46E-04
Y93	2.43E-08	0.	6.62E-10	0.	0.	0.	1.92E-04
ZR93	1.93E-07	9.18E-08	5.54E-08	0.	2.71E-07	0.	2.39E-05
ZR95	2.06E-07	5.02E-08	3.56E-08	0.	5.41E-08	0.	2.50E-05
ZR97	1.48E-08	2.54E-09	1.16E-09	0.	2.56E-09	0.	1.62E-04
NB93M	1.23E-07	3.33E-08	1.04E-08	0.	3.25E-08	0.	3.98E-06
NB95	4.20E-08	1.73E-08	1.00E-08	0.	1.24E-08	0.	1.46E-05
NB97	4.59E-10	9.79E-11	3.53E-11	0.	7.65E-11	0.	3.09E-05
MO93	0.	5.65E-05	1.82E-06	0.	1.13E-05	0.	1.21E-06
MO99	0.	3.40E-05	6.63E-06	0.	5.08E-05	0.	1.12E-05
TC99M	1.92E-09	3.96E-09	5.10E-08	0.	4.26E-08	2.07E-09	1.15E-06
TC99	1.08E-06	1.46E-06	4.55E-07	0.	1.23E-05	1.42E-07	6.31E-06
TC101	2.27E-09	2.86E-09	2.83E-08	0.	3.40E-08	1.56E-09	4.86E-07
RU103	1.48E-06	0.	4.95E-07	0.	3.08E-06	0.	1.80E-05
RU105	1.36E-07	0.	4.58E-08	0.	1.00E-06	0.	5.41E-05
RU106	2.41E-05	0.	3.01E-06	0.	2.85E-05	0.	1.83E-04
RH105	1.09E-06	7.13E-07	4.79E-07	0.	1.98E-06	0.	1.77E-05
PD107	0.	1.19E-06	8.45E-08	0.	6.79E-06	0.	9.46E-07
PD109	0.	1.50E-06	3.62E-07	0.	5.51E-06	0.	3.68E-05
AG110M	9.96E-07	7.27E-07	4.81E-07	0.	1.04E-06	0.	3.77E-05
AG111	5.20E-07	2.02E-07	1.07E-07	0.	4.22E-07	0.	4.82E-05
CD113M	0.	1.77E-05	6.52E-07	0.	1.34E-05	0.	2.66E-05
CD115M	0.	1.42E-05	4.93E-07	0.	7.41E-06	0.	8.09E-05
SN123	2.49E-04	3.89E-06	6.50E-06	3.91E-06	0.	0.	6.58E-05
SN125	7.41E-05	1.38E-06	3.29E-06	1.36E-06	0.	0.	1.11E-04
SN126	5.53E-04	7.26E-06	1.80E-05	1.91E-06	0.	0.	2.52E-05
SB124	2.14E-05	3.15E-07	6.63E-06	5.68E-08	0.	1.34E-05	6.60E-05
SB125	1.23E-05	1.19E-07	2.53E-06	1.54E-08	0.	7.72E-06	1.64E-05
SB126	8.06E-06	1.58E-07	2.91E-06	6.19E-08	0.	5.07E-06	8.35E-05
SB127	2.23E-06	3.98E-08	6.90E-07	2.84E-08	0.	1.15E-06	5.91E-05
TE125M	2.33E-05	7.79E-06	3.15E-06	7.84E-06	0.	0.	1.11E-05
TE127M	5.85E-05	1.94E-05	7.08E-06	1.69E-05	1.44E-04	0.	2.36E-05
TE127	1.00E-06	3.35E-07	2.15E-07	8.14E-07	2.44E-06	0.	2.10E-05
TE129M	1.00E-04	3.43E-05	1.54E-05	3.84E-05	2.50E-04	0.	5.97E-05
TE129	2.84E-07	9.79E-08	6.63E-08	2.38E-07	7.07E-07	0.	2.27E-05
TE131M	1.52E-05	6.12E-06	5.05E-06	1.24E-05	4.21E-05	0.	1.03E-04
TE131	1.76E-07	6.50E-08	4.94E-08	1.57E-07	4.50E-07	0.	7.11E-06
TE132	2.08E-05	1.03E-05	9.61E-06	1.52E-05	6.44E-05	0.	3.81E-05
TE133M	3.91E-07	1.79E-07	1.71E-07	3.45E-07	1.22E-06	0.	1.93E-05
TE134	2.67E-07	1.34E-07	1.38E-07	2.39E-07	9.03E-07	0.	3.06E-06
I129	2.86E-05	2.12E-05	1.55E-05	1.36E-02	2.51E-05	0.	4.24E-07
I130	6.00E-06	1.32E-05	5.30E-06	1.48E-03	1.45E-05	0.	2.83E-06
I131	3.59E-05	4.23E-05	1.86E-05	1.39E-02	4.94E-05	0.	1.51E-06

INGESTION DOSE COMMITMENT FACTORS

INFANT INGESTION DOSE COMMITMENT FACTORS (MREM/50Y PER PCI INGESTED IN FIRST YR)

ISOTOPE	BONE	LIVER	TOTAL BODY	THYROID	KIDNEY	LUNG	GI-LLI
I132	1.66E-06	3.37E-06	1.20E-06	1.58E-04	3.76E-06	0.	2.73E-06
I133	1.25E-05	1.82E-05	5.33E-06	3.31E-03	2.14E-05	0.	3.08E-06
I134	8.69E-07	1.78E-06	6.33E-07	4.15E-05	1.99E-06	0.	1.84E-06
I135	3.64E-06	7.24E-06	2.64E-06	6.49E-04	8.07E-06	0.	2.62E-06
XE131M	0.	0.	0.	0.	0.	0.	0.
XE133M	0.	0.	0.	0.	0.	0.	0.
XE133	0.	0.	0.	0.	0.	0.	0.
XE135M	0.	0.	0.	0.	0.	0.	0.
XE135	0.	0.	0.	0.	0.	0.	0.
XE137	0.	0.	0.	0.	0.	0.	0.
XE138	0.	0.	0.	0.	0.	0.	0.
CS134M	1.76E-07	2.93E-07	1.48E-07	0.	1.13E-07	2.60E-08	2.32E-07
CS134	3.77E-04	7.03E-04	7.10E-05	0.	1.81E-04	7.42E-05	1.91E-06
CS135	1.33E-04	1.21E-04	6.30E-06	0.	3.44E-05	1.31E-05	4.37E-07
CS136	4.59E-05	1.35E-04	5.04E-05	0.	5.38E-05	1.10E-05	2.05E-06
CS137	5.22E-04	6.11E-04	4.33E-05	0.	1.64E-04	6.64E-05	1.91E-06
CS138	4.81E-07	7.82E-07	3.79E-07	0.	3.90E-07	6.09E-08	1.25E-06
CS139	3.10E-07	4.24E-07	1.62E-07	0.	2.19E-07	3.30E-08	2.66E-08
BA139	8.81E-07	5.84E-10	2.55E-08	0.	3.51E-10	3.54E-10	5.58E-05
BA140	1.71E-04	1.71E-07	8.81E-06	0.	4.06E-08	1.05E-07	4.20E-05
BA141	4.25E-07	2.91E-10	1.34E-08	0.	1.75E-10	1.77E-10	5.19E-06
BA142	1.84E-07	1.53E-10	9.06E-09	0.	8.81E-11	9.26E-11	7.59E-07
LA140	2.11E-08	8.32E-09	2.14E-09	0.	0.	0.	9.77E-05
LA141	2.89E-09	8.38E-10	1.46E-10	0.	0.	0.	9.61E-05
LA142	1.10E-09	4.04E-10	9.67E-11	0.	0.	0.	6.86E-05
CE141	7.87E-08	4.80E-08	5.65E-09	0.	1.48E-08	0.	2.48E-05
CE143	1.48E-08	9.82E-06	1.12E-09	0.	2.86E-09	0.	5.73E-05
CE144	2.98E-06	1.22E-06	1.67E-07	0.	4.93E-07	0.	1.71E-04
PR143	8.18E-08	3.04E-08	4.03E-09	0.	1.13E-08	0.	4.29E-05
PR144	2.74E-10	1.06E-10	1.38E-11	0.	3.84E-11	0.	4.93E-06
ND147	5.53E-08	5.68E-08	3.48E-09	0.	2.19E-08	0.	3.60E-05
PM147	3.88E-07	3.27E-08	1.59E-08	0.	4.88E-08	0.	9.27E-06
PM148M	1.65E-07	4.18E-08	3.28E-08	0.	4.80E-08	0.	5.443-05
PM148	6.32E-08	9.13E-09	4.60E-09	0.	1.09E-08	0.	9.74E-05
PM149	1.38E-08	1.81E-09	7.90E-10	0.	2.20E-09	0.	4.86E-05
PM151	6.18E-09	9.01E-10	4.56E-10	0.	1.07E-09	0.	4.17E-05
SM151	2.90E-07	6.67E-08	1.44E-08	0.	4.53E-08	0.	5.58E-06
SM153	7.72E-09	5.97E-09	4.58E-10	0.	1.25E-09	0.	3.12E-05
EU152	6.74E-07	1.79E-07	1.51E-07	0.	5.02E-07	0.	1.59E-05
EU154	2.64E-06	3.67E-07	2.20E-07	0.	9.95E-07	0.	4.58E-05
EU155	5.42E-07	6.25E-08	3.23E-08	0.	1.40E-07	0.	8.37E-05
EU156	1.14E-07	7.06E-08	1.12E-08	0.	3.26E-08	0.	6.67E-05
TB160	2.59E-07	0.	3.24E-08	0.	7.37E-08	0.	3.45E-05
HO166M	1.25E-06	2.69E-07	2.13E-07	0.	3.57E-07	0.	0.
W181	8.85E-08	2.72E-08	3.04E-09	0.	0.	0.	3.82E-07
W185	3.62E-06	1.13E-06	1.29E-07	0.	0.	0.	1.62E-05
W187	9.03E-07	6.28E-07	2.17E-07	0.	0.	0.	3.69E-05

INGESTION DOSE COMMITMENT FACTORS

INFANT INGESTION DOSE COMMITMENT FACTORS (MREM/50Y PER PCI INGESTED IN FIRST YR)

ISOTOPE	BONE	LIVER	TOTAL BODY	THYROID	KIDNEY	LUNG	GI-LLI
PB210	5.28E-02	1.42E-02	2.38E-03	0.	4.33E-02	0.	5.62E-05
BI210	4.16E-06	2.68E-05	3.58E-07	0.	2.08E-04	0.	5.27E-05
PO210	3.10E-03	5.93E-03	7.41E-04	0.	1.26E-02	0.	6.61E-05
RN222	0.	0.	0.	0.	0.	0.	0.
RA223	4.41E-02	6.42E-05	8.82E-03	0.	1.17E-03	0.	3.43E-04
RA224	1.46E-02	3.29E-05	2.91E-03	0.	6.00E-04	0.	3.86E-04
RA225	5.78E-02	6.42E-05	1.15E-02	0.	1.19E-03	0.	3.24E-04
RA226	6.20E-01	4.76E-05	5.14E-01	0.	8.71E-04	0.	3.44E-04
RA228	4.32E-01	2.58E-05	4.86E-01	0.	4.73E-04	0.	5.86E-05
AC225	3.92E-05	5.03E-05	2.63E-06	0.	3.69E-06	0.	4.36E-04
AC227	4.49E-03	7.67E-04	2.79E-04	0.	1.56E-04	0.	8.50E-05
TH227	1.20E-04	2.01E-06	3.45E-06	0.	7.41E-06	0.	5.70E-04
TH228	2.47E-03	3.38E-05	8.36E-05	0.	1.58E-04	0.	5.84E-04
TH229	1.48E-02	1.94E-04	7.29E-04	0.	9.29E-04	0.	5.31E-04
TH230	3.80E-03	1.90E-04	1.06E-04	0.	9.12E-04	0.	6.24E-05
TH232	4.24E-03	1.63E-04	1.65E-04	0.	7.79E-04	0.	5.31E-05
TH234	6.92E-07	3.77E-08	2.00E-08	0.	1.39E-07	0.	1.19E-04
PA231	7.57E-03	2.50E-04	3.02E-04	0.	1.34E-03	0.	7.44E-05
PA233	3.11E-08	6.09E-09	5.43E-09	0.	1.67E-08	0.	1.46E-05
U232	2.42E-02	0.	2.16E-03	0.	2.37E-03	0.	7.04E-05
U233	5.08E-03	0.	3.87E-04	0.	1.08E-03	0.	6.51E-05
U234	4.88E-03	0.	3.80E-04	0.	1.06E-03	0.	6.37E-05
U235	4.67E-03	0.	3.56E-04	0.	9.93E-04	0.	8.10E-05
U236	4.67E-03	0.	3.64E-04	0.	1.01E-03	0.	5.98E-05
U237	4.95E-07	0.	1.32E-07	0.	1.23E-06	0.	2.11E-05
U238	4.47E-03	0.	3.33E-04	0.	9.28E-04	0.	5.71E-05
NP237	2.53E-03	1.93E-04	1.05E-04	0.	6.34E-04	0.	8.23E-05
NP238	1.24E-07	3.12E-09	1.92E-09	0.	6.81E-09	0.	4.17E-05
NP239	1.11E-08	9.93E-10	5.61E-10	0.	1.98E-09	0.	2.87E-05
PU238	1.34E-03	1.69E-04	3.40E-05	0.	1.21E-04	0.	7.57E-05
PU239	1.45E-03	1.77E-04	3.54E-05	0.	1.28E-04	0.	6.91E-05
PU240	1.45E-03	1.77E-04	3.54E-05	0.	1.28E-04	0.	7.04E-05
PU241	4.38E-05	1.90E-06	8.82E-07	0.	3.17E-06	0.	1.45E-06
PU242	1.35E-03	1.70E-04	3.41E-05	0.	1.23E-04	0.	6.77E-05
PU244	1.57E-03	1.95E-04	3.91E-05	0.	1.41E-04	0.	1.01E-04
AM241	1.53E-03	7.18E-04	1.09E-04	0.	6.55E-04	0.	7.70E-05
AM242M	1.58E-03	7.02E-04	1.13E-04	0.	6.64E-04	0.	9.69E-05
AM243	1.51E-03	6.88E-04	1.06E-04	0.	6.36E-04	0.	9.03E-05
CM242	1.37E-04	1.24E-04	9.10E-06	0.	2.62E-05	0.	8.23E-05
CM243	1.45E-03	6.88E-04	8.98E-05	0.	3.27E-04	0.	8.10E-05
CM244	1.22E-03	6.16E-04	7.59E-05	0.	2.71E-04	0.	7.84E-05
CM245	1.88E-03	7.49E-04	1.13E-04	0.	4.32E-04	0.	7.30E-05
CM246	1.87E-03	7.49E-04	1.13E-04	0.	4.31E-04	0.	7.17E-05
CM247	1.82E-03	7.36E-04	1.11E-04	0.	4.24E-04	0.	9.43E-05
CM248	1.51E-02	6.07E-03	9.16E-04	0.	3.50E-03	0.	1.52E-03
CF252	1.24E-03	0.	2.95E-05	0	0.	0.	2.99E-04

INGESTION DOSE COMMITMENT FACTORS

CHILD INGESTION DOSE COMMITMENT FACTORS (MREM/50Y PER PCI INGESTED IN FIRST YR)

ISOTOPE	BONE	LIVER	TOTAL BODY	THYROID	KIDNEY	LUNG	GI-LLI
H3	0.	2.03E-07	2.03E-07	2.03E-07	2.03E-07	2.03E-07	2.03E-07
BE10	1.35E-05	1.57E-06	3.39E-07	0.	1.11E-06	0.	2.75E-05
C14	1.21E-05	2.42E-06	2.42E-06	2.42E-06	2.42E-06	2.42E-06	2.42E-06
N13	3.10E-08	3.10E-08	3.10E-08	3.10E-08	3.10E-08	3.10E-08	3.10E-08
F18	2.49E-06	0.	2.47E-07	0.	0.	0.	6.74E-07
NA22	5.88E-05	5.88E-05	5.88E-05	5.88E-05	5.88E-05	5.88E-05	5.88E-05
NA24	5.80E-06	5.80E-06	5.80E-06	5.80E-06	5.80E-06	5.80E-06	5.80E-06
P32	8.25E-04	3.86E-05	3.18E-05	0.	0.	0.	2.28E-05
AR39	0.	0.	0.	0.	0.	0.	0.
AR41	0.	0.	0.	0.	0.	0.	0.
CA41	3.47E-04	0.	3.79E-05	0.	0.	0.	1.90E-07
SC46	1.97E-08	2.70E-08	1.04E-08	0.	2.30E-08	0.	3.95E-05
CR51	0.	0.	8.90E-09	4.94E-09	1.35E-09	9.02E-09	4.72E-07
MN54	0.	1.07E-05	2.85E-06	0.	3.00E-06	0.	8.98E-06
MN56	0.	3.34E-07	7.54E-08	0.	4.04E-07	0.	4.84E-05
FE55	1.15E-05	6.10E-06	1.89E-06	0.	0.	3.45E-06	1.13E-06
FE59	1.65E-05	2.67E-05	1.33E-05	0.	0.	7.74E-06	2.78E-05
CO57	0.	4.93E-07	9.98E-07	0.	0.	0.	4.04E-06
CO58	0.	1.80E-06	5.51E-06	0.	0.	0.	1.05E-05
CO60	0.	5.29E-06	1.56E-05	0.	0.	0.	2.93E-05
NI59	4.02E-05	1.07E-05	6.82E-06	0.	0.	0.	7.10E-07
NI63	5.38E-04	2.88E-05	1.83E-05	0.	0.	0.	1.94E-06
NI65	2.22E-06	2.09E-07	1.22E-07	0.	0.	0.	2.56E-05
CU64	0.	2.45E-07	1.48E-07	0.	5.92E-07	0.	1.15E-05
ZN65	1.37E-05	3.65E-05	2.27E-05	0.	2.30E-05	0.	6.41E-06
ZN69M	7.10E-07	1.21E-06	1.43E-07	0.	7.03E-07	0.	3.94E-05
ZN69	4.38E-08	6.33E-08	5.85E-09	0.	3.84E-08	0.	3.99E-06
SE79	0.	8.43E-06	1.87E-06	0.	1.37E-05	0.	5.53E-07
BR82	0.	0.	7.55E-06	0.	0.	0.	0.
BR83	0.	0.	1.71E-07	0.	0.	0.	0.
BR84	0.	0.	1.98E-07	0.	0.	0.	0.
BR85	0.	0.	9.12E-09	0.	0.	0.	0.
KR83M	0.	0.	0.	0.	0.	0.	0.
KR85M	0.	0.	0.	0.	0.	0.	0.
KR85	0.	0.	0.	0.	0.	0.	0.
KR87	0.	0.	0.	0.	0.	0.	0.
KR88	0.	0.	0.	0.	0.	0.	0.
KR89	0.	0.	0.	0.	0.	0.	0.
RB86	0.	6.70E-05	4.12E-05	0.	0.	0.	4.31E-06
RB87	0.	3.95E-05	1.83E-05	0.	0.	0.	5.92E-07
RB88	0.	1.90E-07	1.32E-07	0.	0.	0.	9.32E-09
RB89	0.	1.17E-07	1.04E-07	0.	0.	0.	1.02E-09
SR89	1.32E-03	0.	3.77E-05	0.	0.	0.	5.11E-05
SR90	1.70E-02	0.	4.31E-03	0.	0.	0.	2.29E-04
SR91	2.40E-05	0.	9.06E-07	0.	0.	0.	5.30E-05
SR92	9.03E-06	0.	3.62E-07	0.	0.	0.	1.71E-04

INGESTION DOSE COMMITMENT FACTORS

CHILD INGESTION DOSE COMMITMENT FACTORS (MREM/50Y PER PCI INGESTED IN FIRST YR)

ISOTOPE	BONE	LIVER	TOTAL BODY	THYROID	KIDNEY	LUNG	GI-LLI
Y90	4.11E-08	0.	1.10E-09	0.	0.	0.	1.17E-04
Y91M	3.82E-10	0.	1.39E-11	0.	0.	0.	7.48E-07
Y91	6.02E-07	0.	1.61E-08	0.	0.	0.	8.02E-05
Y92	3.60E-09	0.	1.03E-10	0.	0.	0.	1.04E-04
Y93	1.14E-08	0.	3.13E-10	0.	0.	0.	1.70E-04
ZR93	1.67E-07	6.25E-08	4.45E-08	0.	2.42E-07	0.	2.37E-05
ZR95	1.16E-07	2.55E-08	2.27E-08	0.	3.65E-08	0.	2.66E-05
ZR97	6.99E-09	1.01E-09	5.96E-10	0.	1.45E-09	0.	1.53E-04
NB93M	1.05E-07	2.62E-08	8.61E-09	0.	2.83E-08	0.	3.95E-06
NB95	2.25E-08	8.76E-09	6.26E-09	0.	8.23E-09	0.	1.62E-05
NB97	2.17E-10	3.92E-11	1.83E-11	0.	4.35E-11	0.	1.21E-05
MO93	0.	2.41E-05	8.65E-07	0.	6.35E-06	0.	1.22E-06
MO99	0.	1.33E-05	3.29E-06	0.	2.84E-05	0.	1.10E-05
TC99M	9.23E-10	1.81E-09	3.00E-08	0.	2.63E-08	9.19E-10	1.03E-06
TC99	5.35E-07	5.96E-07	2.14E-07	0.	7.02E-06	5.27E-08	6.25E-06
TC101	1.07E-09	1.12E-09	1.42E-08	0.	1.91E-08	5.92E-10	3.56E-09
RU103	7.31E-07	0.	2.81E-07	0.	1.84E-06	0.	1.89E-05
RU105	6.45E-08	0.	2.34E-08	0.	5.67E-07	0.	4.21E-05
RU106	1.17E-05	0.	1.46E-06	0.	1.58E-05	0.	1.82E-04
RH105	5.14E-07	2.76E-07	2.36E-07	0.	1.10E-06	0.	1.71E-05
PD107	0.	4.72E-07	4.01E-08	0.	3.95E-06	0.	9.37E-07
PD109	0.	5.67E-07	1.70E-07	0.	3.04E-06	0.	3.35E-05
AG110M	5.39E-07	3.64E-07	2.91E-07	0.	6.78E-07	0.	4.33E-05
AG111	2.48E-07	7.76E-08	5.12E-08	0.	2.34E-07	0.	4.75E-05
CD113M	0.	1.02E-05	4.34E-07	0.	1.05E-05	0.	2.63E-05
CD115M	0.	5.89E-06	2.51E-07	0.	4.38E-06	0.	8.01E-05
SN123	1.33E-04	1.65E-06	3.24E-06	1.75E-06	0.	0.	6.52E-05
SN125	3.55E-05	5.35E-07	1.59E-06	5.55E-07	0.	0.	1.10E-04
SN126	3.33E-04	4.15E-06	9.46E-06	1.14E-06	0.	0.	2.50E-05
SB124	1.11E-05	1.44E-07	3.89E-06	2.45E-08	0.	6.16E-06	6.94E-05
SB125	7.16E-06	5.52E-08	1.50E-06	6.63E-09	0.	3.99E-06	1.71E-05
SB126	4.40E-06	6.73E-08	1.58E-06	2.58E-08	0.	2.10E-06	8.87E-05
SB127	1.06E-06	1.64E-08	3.68E-07	1.18E-08	0.	4.60E-07	5.97E-05
TE125M	1.14E-05	3.09E-06	1.52E-06	3.20E-06	0.	0.	1.10E-05
TE127M	2.89E-05	7.78E-06	3.43E-06	6.91E-06	8.24E-05	0.	2.34E-05
TE127	4.71E-07	1.27E-07	1.01E-07	3.26E-07	1.34E-06	0.	1.84E-05
TE129M	4.87E-05	1.36E-05	7.56E-06	1.57E-05	1.43E-04	0.	5.94E-05
TE129	1.34E-07	3.74E-08	3.18E-08	9.56E-08	3.92E-07	0.	8.34E-06
TE131M	7.20E-06	2.49E-06	2.65E-06	5.12E-06	2.41E-05	0.	1.01E-04
TE131	8.30E-08	2.53E-08	2.47E-08	6.35E-08	2.51E-07	0.	4.36E-07
TE132	1.01E-05	4.47E-06	5.40E-06	6.51E-06	4.15E-05	0.	4.50E-05
TE133M	1.87E-07	7.56E-08	9.37E-08	1.45E-07	7.18E-07	0.	5.77E-06
TE134	1.29E-07	5.80E-08	7.74E-08	1.02E-07	5.37E-07	0.	5.89E-07
I129	1.39E-05	8.53E-06	7.62E-06	5.58E-03	1.44E-05	0.	4.29E-07
I130	2.92E-06	5.90E-06	3.04E-06	6.50E-04	8.82E-06	0.	2.76E-06
I131	1.72E-05	1.73E-05	9.83E-06	5.72E-03	2.84E-05	0.	1.54E-06

INGESTION DOSE COMMITMENT FACTORS

CHILD INGESTION DOSE COMMITMENT FACTORS (MREM/50Y PER PCI INGESTED IN FIRST YR)

ISOTOPE	BONE	LIVER	TOTAL BODY	THYROID	KIDNEY	LUNG	GI-LLI
I132	8.00E-07	1.47E-06	6.76E-07	6.82E-05	2.25E-06	0.	1.73E-06
I133	5.92E-06	7.32E-06	2.77E-06	1.36E-03	1.22E-05	0.	2.95E-06
I134	4.19E-07	7.78E-07	3.58E-07	1.79E-05	1.19E-06	0.	5.16E-07
I135	1.75E-06	3.15E-06	1.49E-06	2.79E-04	4.83E-06	0.	2.40E-06
XE131M	0.	0.	0.	0.	0.	0.	0.
XE133M	0.	0.	0.	0.	0.	0.	0.
XE133	0.	0.	0.	0.	0.	0.	0.
XE135M	0.	0.	0.	0.	0.	0.	0.
XE135	0.	0.	0.	0.	0.	0.	0.
XE137	0.	0.	0.	0.	0.	0.	0.
XE138	0.	0.	0.	0.	0.	0.	0.
CS134M	8.44E-08	1.25E-07	8.16E-08	0.	6.59E-08	1.09E-08	1.58E-07
CS134	2.34E-04	3.84E-04	8.10E-05	0.	1.19E-04	4.27E-05	2.07E-06
CS135	8.30E-05	5.78E-05	5.93E-06	0.	2.04E-05	6.81E-06	4.33E-07
CS136	2.35E-05	6.46E-05	4.18E-05	0.	3.44E-05	5.13E-06	2.27E-06
CS137	3.27E-04	3.13E-04	4.62E-05	0.	1.02E-04	3.67E-05	1.96E-06
CS138	2.28E-07	3.17E-07	2.01E-07	0.	2.23E-07	2.40E-08	1.46E-07
CS139	1.45E-07	1.61E-07	7.74E-08	0.	1.21E-07	1.22E-08	1.45E-11
BA139	4.14E-07	2.21E-10	1.20E-08	0.	1.93E-10	1.30E-10	2.39E-05
BA140	8.31E-05	7.28E-08	4.85E-06	0.	2.37E-08	4.34E-08	4.21E-05
BA141	2.00E-07	1.12E-10	6.51E-09	0.	9.69E-11	6.58E-10	1.14E-07
BA142	8.74E-08	6.29E-11	4.88E-09	0.	5.09E-11	3.70E-11	1.14E-09
LA140	1.01E-08	3.53E-09	1.19E-09	0.	0.	0.	9.84E-05
LA141	1.35E-09	3.17E-10	6.88E-11	0.	0.	0.	7.05E-05
LA142	5.24E-10	1.67E-10	5.23E-11	0.	0.	0.	3.31E-05
CE141	3.97E-08	1.98E-08	2.94E-09	0.	8.68E-09	0.	2.47E-05
CE143	6.99E-09	3.79E-06	5.49E-10	0.	1.59E-09	0.	5.55E-05
CE144	2.08E-06	6.52E-07	1.11E-07	0.	3.61E-07	0.	1.70E-04
PR143	3.93E-08	1.18E-08	1.95E-09	0.	6.39E-09	0.	4.24E-05
PR144	1.29E-10	3.99E-11	6.49E-12	0.	2.11E-11	0.	8.59E-08
ND147	2.79E-08	2.26E-08	1.75E-09	0.	1.24E-08	0.	3.58E-05
PM147	3.18E-07	2.27E-08	1.22E-08	0.	4.01E-08	0.	9.19E-06
PM148M	1.03E-07	2.05E-08	2.05E-08	0.	3.04E-08	0.	5.78E-05
PM148	3.02E-08	3.63E-09	2.35E-09	0.	6.17E-09	0.	9.70E-05
PM149	6.49E-09	6.90E-10	3.74E-10	0.	1.22E-09	0.	4.71E-05
PM151	2.92E-09	3.55E-10	2.31E-10	0.	6.02E-10	0.	4.03E-05
SM151	2.56E-07	3.81E-08	1.20E-08	0.	3.94E-08	0.	5.53E-06
SM153	3.65E-09	2.27E-09	2.19E-10	0.	6.91E-10	0.	3.02E-05
EU152	6.15E-07	1.12E-07	1.33E-07	0.	4.73E-07	0.	1.84E-05
EU154	2.30E-06	2.07E-07	1.89E-07	0.	9.09E-07	0.	4.81E-05
EU155	4.82E-07	3.47E-08	2.72E-08	0.	1.30E-07	0.	8.69E-05
EU156	5.62E-08	3.01E-08	6.23E-09	0.	1.94E-08	0.	6.83E-05
TB160	1.66E-07	0.	2.06E-08	0.	4.94E-08	0.	3.68E-05
HO166M	1.08E-06	2.26E-07	1.91E-07	0.	3.22E-07	0.	0.
W181	4.23E-06	1.04E-08	1.43E-09	0.	0.	0.	3.79E-07
W185	1.73E-06	4.32E-07	6.05E-08	0.	0.	0.	1.61E-05
W187	4.29E-07	2.54E-07	1.14E-07	0.	0.	0.	3.57E-05

INGESTION DOSE COMMITMENT FACTORS

CHILD INGESTION DOSE COMMITMENT FACTORS (MREM/50Y PER PCI INGESTED IN FIRST YR)

ISOTOPE	BONE	LIVER	TOTAL BODY	THYROID	KIDNEY	LUNG	GI-LLI
PB210	4.75E-02	1.22E-02	2.09E-03	0.	3.67E-02	0.	5.57E-05
BI210	1.97E-06	1.02E-05	1.69E-07	0.	1.15E-04	0.	5.17E-05
PO210	1.52E-03	2.43E-03	3.67E-04	0.	7.56E-03	0.	6.55E-05
RN222	0.	0.	0.	0.	0.	0.	0.
RA223	2.12E-02	2.45E-05	4.24E-03	0.	6.50E-04	0.	3.38E-04
RA224	6.89E-03	1.25E-05	1.38E-03	0.	3.31E-04	0.	3.78E-04
RA225	2.80E-02	2.50E-05	5.59E-03	0.	6.62E-04	0.	3.21E-04
RA226	5.75E-01	1.84E-05	4.72E-01	0.	4.88E-04	0.	3.41E-04
RA228	3.85E-01	9.99E-06	4.32E-01	0.	2.65E-04	0.	5.81E-05
AC225	1.88E-05	1.94E-05	1.26E-06	0.	2.07E-06	0.	4.31E-04
AC227	4.12E-03	6.63E-04	2.55E-04	0.	1.46E-04	0.	8.43E-05
TH227	5.85E-05	7.96E-07	1.69E-06	0.	4.22E-06	0.	5.63E-04
TH228	2.07E-03	2.65E-05	7.00E-05	0.	1.38E-04	0.	5.79E-04
TH229	1.38E-02	1.81E-04	6.80E-04	0.	8.84E-04	0.	5.27E-04
TH230	3.55E-03	1.78E-04	9.91E-05	0.	8.67E-04	0.	6.19E-05
TH232	3.96E-03	1.52E-04	3.01E-04	0.	7.41E-04	0.	5.27E-05
TH234	3.42E-07	1.51E-08	9.88E-09	0.	8.01E-08	0.	1.18E-04
PA231	7.07E-03	2.34E-04	2.81E-04	0.	1.28E-03	0.	7.37E-05
PA233	1.81E-08	2.82E-09	3.16E-09	0.	1.04E-08	0.	1.44E-05
U232	1.76E-02	0.	1.26E-03	0.	1.34E-03	0.	6.98E-05
U233	3.72E-03	0.	2.25E-04	0.	6.10E-04	0.	6.45E-05
U234	3.57E-03	0.	2.21E-04	0.	5.98E-04	0.	6.32E-05
U235	3.42E-03	0.	2.07E-04	0.	5.61E-04	0.	8.03E-05
U236	3.42E-03	0.	2.12E-04	0.	5.73E-04	0.	5.92E-05
U237	2.36E-07	0.	6.27E-08	0.	6.81E-07	0.	2.08E-05
U238	3.27E-03	0.	1.94E-04	0.	5.24E-04	0.	5.66E-05
NP237	2.36E-03	1.81E-04	9.79E-05	0.	6.05E-04	0.	8.16E-05
NP238	5.83E-08	1.18E-09	9.08E-10	0.	3.76E-09	0.	4.04E-05
NP239	5.25E-09	3.77E-10	2.65E-10	0.	1.09E-09	0.	2.79E-05
PU238	1.25E-03	1.56E-04	3.16E-05	0.	1.15E-04	0.	7.50E-05
PU239	1.36E-03	1.65E-04	3.31E-05	0.	1.22E-04	0.	6.85E-05
PU240	1.36E-03	1.65E-04	3.31E-05	0.	1.22E-04	0.	6.98E-05
PU241	4.00E-05	1.72E-06	8.04E-07	0.	2.96E-06	0.	1.44E-06
PU242	1.26E-03	1.59E-04	3.19E-05	0.	1.17E-04	0.	6.71E-05
PU244	1.47E-03	1.82E-04	3.65E-05	0.	1.35E-04	0.	1.00E-04
AM241	1.43E-03	6.40E-04	1.02E-04	0.	6.23E-04	0.	7.64E-05
AM242M	1.47E-03	6.25E-04	1.04E-04	0.	6.30E-04	0.	9.61E-05
AM243	1.41E-03	6.14E-04	9.83E-05	0.	6.06E-04	0.	8.95E-05
CM242	8.80E-05	6.73E-05	5.84E-06	0.	1.87E-05	0.	8.16E-05
CM243	1.33E-03	6.03E-04	8.24E-05	0.	3.08E-04	0.	8.03E-05
CM244	1.11E-03	5.36E-04	6.93E-05	0.	2.54E-04	0.	7.77E-05
CM245	1.76E-03	6.64E-04	1.05E-04	0.	4.11E-04	0.	7.24E-05
CM246	1.74E-03	6.64E-04	1.05E-04	0.	4.10E-04	0.	7.11E-05
CM247	1.70E-03	6.53E-04	1.03E-04	0.	4.04E-04	0.	9.35E-05
CM248	1.41E-02	5.38E-03	8.52E-04	0.	3.33E-03	0.	1.51E-03
CF252	1.07E-03	0.	2.54E-05	0.	0.	0.	2.96E-04

INGESTION DOSE COMMITMENT FACTORS

TEEN INGESTION DOSE COMMITMENT FACTORS (MREM/50Y PER PCI INGESTED IN FIRST YR)

ISOTOPE	BONE	LIVER	TOTAL BODY	THYROID	KIDNEY	LUNG	GI-LLI
H3	0.	1.06E-07	1.06E-07	1.06E-07	1.06E-07	1.06E-07	1.06E-07
BE10	4.48E-06	6.94E-07	1.13E-07	0.	5.30E-07	0.	2.84E-05
C14	4.06E-06	8.12E-07	8.12E-07	8.12E-07	8.12E-07	8.12E-07	8.12E-07
N13	1.15E-08	1.15E-08	1.15E-08	1.15E-08	1.15E-08	1.15E-08	1.15E-08
F18	8.64E-07	0.	9.47E-08	0.	0.	0.	7.78E-08
NA22	2.34E-05	2.34E-05	2.34E-05	2.34E-05	2.34E-05	2.34E-05	2.34E-05
NA24	2.30E-06	2.30E-06	2.30E-06	2.30E-06	2.30E-06	2.30E-06	2.30E-06
P32	2.76E-04	1.71E-05	1.07E-05	0.	0.	0.	2.32E-05
AR39	0.	0.	0.	0.	0.	0.	0.
AR41	0.	0.	0.	0.	0.	0.	0.
CA41	1.97E-04	0.	2.13E-05	0.	0.	0.	1.95E-07
SC46	7.24E-09	1.41E-08	4.18E-09	0.	1.35E-08	0.	4.80E-05
CR51	0.	0.	3.60E-09	2.00E-09	7.89E-10	5.14E-09	6.05E-07
MN54	0.	5.90E-06	1.17E-06	0.	1.76E-06	0.	1.21E-05
MN56	0.	1.58E-07	2.81E-08	0.	2.00E-07	0.	1.04E-05
FE55	3.78E-06	2.68E-06	6.25E-07	0.	0.	1.70E-06	1.16E-06
FE59	5.87E-06	1.37E-05	5.29E-06	0.	0.	4.32E-06	3.24E-05
CO57	0.	2.38E-07	3.99E-07	0.	0.	0.	4.44E-06
CO58	0.	9.72E-07	2.24E-06	0.	0.	0.	1.34E-05
CO60	0.	2.81E-06	6.33E-06	0.	0.	0.	3.66E-05
NI59	1.32E-05	4.66E-06	2.24E-06	0.	0.	0.	7.31E-07
NI63	1.77E-04	1.25E-05	6.00E-06	0.	0.	0.	1.99E-06
NI65	7.49E-07	9.57E-08	4.36E-08	0.	0.	0.	5.193E-06
CU64	0.	1.15E-07	5.41E-08	0.	2.91E-07	0.	8.92E-06
ZN65	5.76E-06	2.00E-05	9.33E-06	0.	1.28E-05	0.	8.47E-06
ZN69M	2.40E-07	5.66E-07	5.19E-08	0.	3.44E-07	0.	3.11E-05
ZN69	1.47E-08	2.80E-08	1.96E-09	0.	1.83E-08	0.	5.16E-08
SE79	0.	3.73E-06	6.27E-07	0.	6.50E-06	0.	5.70E-07
BR82	0.	0.	3.04E-06	0.	0.	0.	0.
BR83	0.	0.	5.74E-08	0.	0.	0.	0.
BR84	0.	0.	7.22E-08	0.	0.	0.	0.
BR85	0.	0.	3.05E-09	0.	0.	0.	0.
KR83M	0.	0.	0.	0.	0.	0.	0.
KR85M	0.	0.	0.	0.	0.	0.	0.
KR85	0.	0.	0.	0.	0.	0.	0.
KR87	0.	0.	0.	0.	0.	0.	0.
KR88	0.	0.	0.	0.	0.	0.	0.
KR89	0.	0.	0.	0.	0.	0.	0.
RB86	0.	2.98E-05	1.40E-05	0.	0.	0.	4.41E-06
RB87	0.	1.75E-05	6.11E-06	0.	0.	0.	6.11E-07
RB88	0.	8.52E-08	4.54E-08	0.	0.	0.	7.30E-15
RB89	0.	5.50E-08	3.89E-08	0.	0.	0.	8.43E-17
SR89	4.40E-04	0.	1.26E-05	0.	0.	0.	5.24E-05
SR90	8.30E-03	0.	2.05E-03	0.	0.	0.	2.33E-04
SR91	8.07E-06	0.	3.21E-07	0.	0.	0.	3.66E-05
SR92	3.05E-06	0.	1.30E-07	0.	0.	0.	7.77E-05

INGESTION DOSE COMMITMENT FACTORS

TEEN INGESTION DOSE COMMITMENT FACTORS (MREM/50Y PER PCI INGESTED IN FIRST YR)

ISOTOPE	BONE	LIVER	TOTAL BODY	THYROID	KIDNEY	LUNG	GI-LLI
Y90	1.37E-08	0.	3.69E-10	0.	0.	0.	1.13E-04
Y91M	1.29E-10	0.	4.93E-12	0.	0.	0.	6.09E-09
Y91	2.01E-07	0.	5.39E-09	0.	0.	0.	8.24E-05
Y92	1.21E-09	0.	3.50E-11	0.	0.	0.	3.32E-05
Y93	3.83E-09	0.	1.05E-10	0.	0.	0.	1.17E-04
ZR93	5.53E-08	2.73E-08	1.49E-08	0.	9.65E-08	0.	2.58E-05
ZR95	4.12E-08	1.30E-08	8.94E-09	0.	1.91E-08	0.	3.00E-05
ZR97	2.37E-09	4.69E-10	2.16E-10	0.	7.11E-10	0.	1.27E-04
NB93M	3.44E-08	1.13E-08	2.83E-09	0.	1.32E-08	0.	4.07E-06
NB95	8.22E-09	4.56E-09	2.51E-09	0.	4.42E-09	0.	1.95E-05
NB97	7.37E-11	1.83E-11	6.68E-12	0.	2.14E-11	0.	4.37E-07
MO93	0.	1.06E-05	2.90E-07	0.	3.04E-06	0.	1.29E-06
MO99	0.	6.03E-06	1.15E-06	0.	1.38E-05	0.	1.08E-05
TC99M	3.32E-10	9.26E-10	1.20E-08	0.	1.38E-08	5.14E-10	6.08E-07
TC99	1.79E-07	2.63E-07	7.17E-08	0.	3.34E-06	2.72E-08	6.44E-06
TC101	3.60E-10	5.12E-10	5.03E-09	0.	9.26E-09	3.12E-10	8.75E-17
RU103	2.55E-07	0.	1.09E-07	0.	8.99E-07	0.	2.13E-05
RU105	2.18E-08	0.	8.46E-09	0.	2.75E-07	0.	1.76E-05
RU106	3.92E-06	0.	4.94E-07	0.	7.56E-06	0.	1.88E-04
RH105	1.73E-07	1.25E-07	8.20E-08	0.	5.31E-07	0.	1.59E-05
PD107	0.	2.08E-07	1.34E-08	0.	1.88E-06	0.	9.66E-07
PD109	0.	2.51E-07	5.70E-08	0.	1.45E-06	0.	2.53E-05
AG110M	2.05E-07	1.94E-07	1.18E-07	0.	3.70E-07	0.	5.45E-05
AG111	8.29E-08	3.44E-08	1.73E-08	0.	1.12E-07	0.	4.80E-05
CD113M	0.	4.51E-06	1.45E-07	0.	4.99E-06	0.	2.71E-05
CD115M	0.	2.60E-06	8.39E-08	0.	2.08E-06	0.	8.23E-05
SN123	4.44E-05	7.29E-07	1.08E-06	5.84E-07	0.	0.	6.71E-05
SN125	1.19E-05	2.37E-07	5.37E-07	1.86E-07	0.	0.	1.12E-04
SN126	1.16E-04	2.16E-06	3.30E-06	5.69E-07	0.	0.	2.58E-05
SB124	3.87E-06	7.13E-08	1.51E-06	8.78E-09	0.	3.38E-06	7.80E-05
SB125	2.48E-06	2.71E-08	5.80E-07	2.37E-09	0.	2.18E-06	1.93E-05
SB126	1.59E-06	3.25E-08	5.71E-07	8.99E-09	0.	1.14E-06	9.41E-05
SB127	3.63E-07	7.76E-09	1.37E-07	4.08E-09	0.	2.47E-07	6.16E-05
TE125M	3.83E-06	1.38E-06	5.12E-07	1.07E-06	0.	0.	1.13E-05
TE127M	9.67E-06	3.43E-06	1.15E-06	2.30E-06	3.92E-05	0.	2.41E-05
TE127	1.58E-07	5.60E-08	3.40E-08	1.09E-07	6.40E-07	0.	1.22E-05
TE129M	1.63E-05	6.05E-06	2.58E-06	5.26E-06	6.82E-05	0.	6.12E-05
TE129	4.48E-08	1.67E-08	1.09E-08	3.20E-08	1.88E-07	0.	2.45E-07
TE131M	2.44E-06	1.17E-06	9.76E-07	1.76E-06	1.22E-05	0.	9.39E-05
TE131	2.79E-08	1.15E-08	8.72E-09	2.15E-08	1.22E-07	0.	2.29E-09
TE132	3.49E-06	2.21E-06	2.08E-06	2.33E-06	2.12E-05	0.	7.00E-05
TE133M	6.44E-08	3.66E-08	3.56E-08	5.11E-08	3.62E-07	0.	1.48E-07
TE134	4.47E-08	2.87E-08	3.00E-08	3.67E-08	2.74E-07	0.	1.66E-09
I129	4.66E-06	3.92E-06	6.54E-06	4.77E-03	7.01E-06	0.	4.57E-07
I130	1.03E-06	2.98E-06	1.19E-06	2.43E-04	4.59E-06	0.	2.29E-06
I131	5.85E-06	8.19E-06	4.40E-06	2.39E-03	1.41E-05	0.	1.62E-06

INGESTION DOSE COMMITMENT FACTORS

TEEN INGESTION DOSE COMMITMENT FACTORS (MREM/50Y PER PCI INGESTED IN FIRST YR)

ISOTOPE	BONE	LIVER	TOTAL BODY	THYROID	KIDNEY	LUNG	GI-LLI
I132	2.79E-07	7.30E-07	2.62E-07	2.46E-05	1.15E-06	0.	3.18E-07
I133	2.01E-06	3.41E-06	1.04E-06	4.76E-04	5.98E-06	0.	2.58E-06
I134	1.46E-07	3.87E-07	1.39E-07	6.45E-06	6.10E-07	0.	5.10E-09
I135	6.10E-07	1.57E-06	5.82E-07	1.01E-04	2.48E-06	0.	1.74E-06
XE131M	0.	0.	0.	0.	0.	0.	0.
XE133M	0.	0.	0.	0.	0.	0.	0.
XE133	0.	0.	0.	0.	0.	0.	0.
XE135M	0.	0.	0.	0.	0.	0.	0.
XE135	0.	0.	0.	0.	0.	0.	0.
XE137	0.	0.	0.	0.	0.	0.	0.
XE138	0.	0.	0.	0.	0.	0.	0.
CS134M	2.94E-08	6.09E-08	3.13E-08	0.	3.39E-08	5.95E-09	4.05E-08
CS134	8.37E-05	1.97E-04	9.14E-05	0.	6.26E-05	2.39E-05	2.45E-06
CS135	2.78E-05	2.55E-05	5.96E-06	0.	9.73E-06	3.52E-06	4.46E-07
CS136	8.59E-06	3.38E-05	2.27E-05	0.	1.84E-05	2.90E-06	2.72E-06
CS137	1.12E-04	1.49E-04	5.19E-05	0.	5.07E-05	1.97E-05	2.12E-06
CS138	7.76E-08	1.49E-07	7.45E-08	0.	1.10E-07	1.28E-08	6.76E-11
CS139	4.87E-08	7.17E-08	2.63E-08	0.	5.79E-08	6.34E-09	3.33E-23
BA139	1.39E-07	9.78E-11	4.05E-09	0.	9.22E-11	6.74E-11	1.24E-06
BA140	2.84E-05	3.48E-08	1.83E-06	0.	1.18E-08	2.34E-08	4.38E-05
BA141	6.71E-08	5.01E-11	2.24E-09	0.	4.65E-11	3.43E-11	1.43E-13
BA142	2.99E-08	2.99E-11	1.84E-09	0.	2.53E-11	1.99E-11	9.18E-20
LA140	3.48E-09	1.71E-09	4.55E-10	0.	0.	0.	9.82E-05
LA141	4.55E-10	1.40E-10	2.31E-11	0.	0.	0.	2.48E-05
LA142	1.79E-10	7.95E-11	1.98E-11	0.	0.	0.	2.42E-06
CE141	1.33E-08	8.88E-09	1.02E-09	0.	4.18E-09	0.	2.54E-05
CE143	2.35E-09	1.71E-06	1.91E-10	0.	7.67E-10	0.	5.14E-05
CE144	6.96E-07	2.88E-07	3.74E-08	0.	1.72E-07	0.	1.75E-04
PR143	1.31E-08	5.23E-09	6.52E-10	0.	3.04E-09	0.	4.31E-05
PR144	4.30E-11	1.76E-11	2.18E-12	0.	1.01E-11	0.	4.74E-14
ND147	9.38E-09	1.02E-08	6.11E-10	0.	5.99E-09	0.	3.68E-05
PM147	1.05E-07	9.96E-09	4.06E-09	0.	1.90E-08	0.	9.47E-06
PM148M	4.14E-08	1.05E-08	8.21E-09	0.	1.59E-08	0.	6.61E-05
PM148	1.02E-08	1.66E-09	8.36E-10	0.	3.00E-09	0.	9.90E-05
PM149	2.17E-09	3.05E-10	1.25E-10	0.	5.81E-10	0.	4.49E-05
PM151	9.87E-10	1.63E-10	8.25E-11	0.	2.93E-10	0.	3.66E-05
SM151	8.73E-08	1.68E-08	3.94E-09	0.	1.84E-08	0.	5.70E-06
SM153	1.22E-09	1.01E-09	7.43E-11	0.	3.30E-10	0.	2.85E-05
EU152	2.45E-07	5.90E-08	5.20E-08	0.	2.74E-07	0.	2.17E-05
EU154	7.91E-07	1.02E-07	7.19E-08	0.	4.56E-07	0.	5.39E-05
EU155	1.74E-07	1.68E-08	1.04E-08	0.	6.57E-08	0.	9.63E-05
EU156	1.92E-08	1.44E-08	2.35E-09	0.	9.69E-09	0.	7.36E-05
TB160	6.47E-08	0.	8.07E-09	0.	2.56E-08	0.	4.19E-05
HO166M	3.57E-07	1.10E-07	7.96E-08	0.	1.61E-07	0.	0.
W181	1.42E-08	4.58E-09	4.79E-10	0.	0.	0.	3.90E-07
W185	5.79E-07	1.91E-07	2.02E-08	0.	0.	0.	1.65E-05
W187	1.46E-07	1.19E-07	4.17E-08	0.	0.	0.	3.22E-05

INGESTION DOSE COMMITMENT FACTORS

TEEN INGESTION DOSE COMMITMENT FACTORS (MREM/50Y PER PCI INGESTED IN FIRST YR)

ISOTOPE	BONE	LIVER	TOTAL BODY	THYROID	KIDNEY	LUNG	GI-LLI
PB210	1.81E-02	5.44E-03	7.01E-04	0.	1.72E-02	0.	5.74E-05
BI210	6.59E-07	4.51E-06	5.66E-08	0.	5.48E-05	0.	5.15E-05
PO210	6.09E-04	1.07E-03	1.23E-04	0.	3.60E-03	0.	6.75E-05
RN222	0.	0.	0.	0.	0.	0.	0.
RA223	7.11E-03	1.08E-05	1.42E-03	0.	3.10E-04	0.	3.43E-04
RA224	2.31E-03	5.52E-06	4.61E-04	0.	1.58E-04	0.	3.71E-04
RA225	9.37E-03	1.10E-05	1.87E-03	0.	3.15E-04	0.	3.27E-04
RA226	3.22E-01	8.13E-06	2.39E-01	0.	2.32E-04	0.	3.51E-04
RA228	1.37E-01	4.41E-06	1.51E-01	0.	1.26E-04	0.	5.98E-05
AC225	6.29E-06	8.59E-06	4.22E-07	0.	9.85E-07	0.	4.36E-04
AC227	2.05E-03	3.03E-04	1.22E-04	0.	8.81E-05	0.	8.68E-05
TH227	1.96E-05	3.52E-07	5.65E-07	0.	2.01E-06	0.	5.75E-04
TH228	6.80E-04	1.14E-05	2.30E-05	0.	6.41E-05	0.	5.97E-04
TH229	8.39E-03	1.26E-04	4.11E-04	0.	6.10E-04	0.	5.43E-04
TH230	2.16E-03	1.23E-04	6.00E-05	0.	5.99E-04	0.	6.38E-05
TH232	2.42E-03	1.05E-04	1.63E-04	0.	5.11E-04	0.	5.43E-05
TH234	1.14E-07	6.68E-09	3.31E-09	0.	3.81E-08	0.	1.21E-04
PA231	4.31E-03	1.62E-04	1.68E-04	0.	9.10E-04	0.	7.60E-05
PA233	7.33E-09	1.41E-09	1.26E-09	0.	5.32E-09	0.	1.61E-05
U232	5.89E-03	0.	4.21E-04	0.	6.38E-04	0.	7.19E-05
U233	1.24E-03	0.	7.54E-05	0.	2.90E-04	0.	6.65E-05
U234	1.19E-03	0.	7.39E-05	0.	2.85E-04	0.	6.51E-05
U235	1.14E-03	0.	6.94E-05	0.	2.67E-04	0.	8.28E-05
U236	1.14E-03	0.	7.09E-05	0.	2.73E-04	0.	6.11E-05
U237	7.89E-08	0.	2.10E-08	0.	3.24E-07	0.	2.09E-05
U238	1.09E-03	0.	6.49E-05	0.	2.50E-04	0.	5.83E-05
NP237	1.44E-03	1.25E-04	5.85E-05	0.	4.33E-04	0.	8.41E-05
NP238	1.95E-08	5.22E-10	3.04E-10	0.	1.79E-09	0.	3.83E-05
NP239	1.76E-09	1.66E-10	9.22E-11	0.	5.21E-10	0.	2.67E-05
PU238	7.21E-04	1.02E-04	1.82E-05	0.	7.80E-05	0.	7.73E-05
PU239	8.27E-04	1.12E-04	2.01E-05	0.	8.57E-05	0.	7.06E-05
PU240	8.26E-04	1.12E-04	2.01E-05	0.	8.56E-05	0.	7.19E-05
PU241	1.84E-05	9.42E-07	3.69E-07	0.	1.71E-06	0.	1.48E-06
PU242	7.66E-04	1.08E-04	1.94E-05	0.	8.25E-05	0.	6.92E-05
PU244	8.95E-04	1.23E-04	2.22E-05	0.	9.45E-05	0.	1.03E-04
AM241	8.62E-04	3.29E-04	5.75E-05	0.	4.31E-04	0.	7.87E-05
AM242M	8.70E-04	3.19E-04	5.80E-05	0.	4.30E-04	0.	9.90E-05
AM243	8.60E-04	3.17E-04	5.62E-05	0.	4.22E-04	0.	9.23E-05
CM242	2.94E-05	2.97E-05	1.95E-06	0.	8.89E-06	0.	8.40E-05
CM243	6.91E-04	2.86E-04	4.09E-05	0.	1.91E-04	0.	8.28E-05
CM244	5.32E-04	2.49E-04	3.19E-05	0.	1.49E-04	0.	8.00E-05
CM245	1.07E-03	3.33E-04	6.10E-05	0.	2.85E-04	0.	7.46E-05
CM246	1.06E-03	3.32E-04	6.09E-05	0.	2.84E-04	0.	7.33E-05
CM247	1.03E-03	3.27E-04	6.00E-05	0.	2.80E-04	0.	9.63E-05
CM248	8.60E-03	2.69E-03	4.95E-04	0.	2.31E-03	0.	1.55E-03
CR252	3.51E-04	0.	8.37E-06	0.	0.	0.	3.05E-04

INGESTION DOSE COMMITMENT FACTORS

ADULT INGESTION DOSE COMMITMENT FACTORS (MREM/50Y PER PCI INGESTED IN FIRST YR)

ISOTOPE	BONE	LIVER	TOTAL BODY	THYROID	KIDNEY	LUNG	GI-LLI
H3	0.	1.05E-07	1.05E-07	1.05E-07	1.05E-07	1.05E-07	1.05E-07
BE10	3.18E-06	4.91E-07	7.94E-08	0.	3.71E-07	0.	2.68E-05
C14	2.84E-06	5.68E-07	5.68E-07	5.68E-07	5.68E-07	5.68E-07	5.68E-07
N13	8.36E-09	8.36E-09	8.36E-09	8.36E-09	8.36E-09	8.36E-09	8.36E-09
F18	6.24E-07	0.	6.92E-08	0.	0.	0.	1.85E-08
NA22	1.74E-05	1.74E-05	1.74E-05	1.74E-05	1.74E-05	1.74E-05	1.74E-05
NA24	1.70E-06	1.70E-06	1.70E-06	1.70E-06	1.70E-06	1.70E-06	1.70E-06
P32	1.93E-04	1.20E-05	7.46E-06	0.	0.	0.	2.17E-05
AR39	0.	0.	0.	0.	0.	0.	0.
AR41	0.	0.	0.	0.	0.	0.	0.
CA41	1.83E-05	0.	2.00E-05	0.	0.	0.	1.84E-07
SC46	5.51E-09	1.07E-08	3.11E-09	0.	9.99E-09	0.	5.21E-05
CR51	0.	0.	2.66E-09	1.59E-09	5.86E-10	3.53E-09	6.69E-07
MN54	0.	4.57E-06	8.72E-07	0.	1.36E-06	0.	1.40E-05
MN56	0.	1.15E-07	2.04E-08	0.	1.46E-07	0.	3.67E-06
FE55	2.75E-06	1.90E-06	4.43E-07	0.	0.	1.06E-06	1.09E-06
FE59	4.34E-06	1.02E-05	3.91E-06	0.	0.	2.85E-06	3.40E-05
CO57	0.	1.75E-07	2.91E-07	0.	0.	0.	4.44E-06
CO58	0.	7.45E-07	1.67E-06	0.	0.	0.	1.51E-05
CO60	0.	2.14E-06	4.72E-06	0.	0.	0.	4.02E-05
NI59	9.76E-06	3.35E-06	1.63E-06	0.	0.	0.	6.90E-07
NI63	1.30E-04	9.01E-06	4.36E-06	0.	0.	0.	1.88E-06
NI65	5.28E-07	6.86E-08	3.13E-08	0.	0.	0.	1.74E-06
CU64	0.	8.33E-08	3.91E-08	0.	2.10E-07	0.	7.10E-06
ZN65	4.84E-06	1.54E-05	6.96E-06	0.	1.03E-05	0.	9.70E-06
ZN69M	1.70E-07	4.08E-07	3.73E-08	0.	2.47E-07	0.	2.49E-05
ZN69	1.03E-08	1.97E-08	1.37E-09	0.	1.28E-08	0.	2.96E-09
SE79	0.	2.63E-06	4.39E-07	0.	4.55E-06	0.	5.38E-07
BR82	0.	0.	2.26E-06	0.	0.	0.	2.59E-06
BR83	0.	0.	4.02E-08	0.	0.	0.	5.79E-08
BR84	0.	0.	5.21E-08	0.	0.	0.	4.09E-13
BR85	0.	0.	2.14E-09	0.	0.	0.	0.
KR83M	0.	0.	0.	0.	0.	0.	0.
KR85M	0.	0.	0.	0.	0.	0.	0.
KR85	0.	0.	0.	0.	0.	0.	0.
KR87	0.	0.	0.	0.	0.	0.	0.
KR88	0.	0.	0.	0.	0.	0.	0.
KR89	0.	0.	0.	0.	0.	0.	0.
RB86	0.	2.11E-05	9.83E-06	0.	0.	0.	4.16E-06
RB87	0.	1.23E-05	4.28E-06	0.	0.	0.	5.76E-07
RB88	0.	6.05E-08	3.21E-08	0.	0.	0.	8.36E-19
RB89	0.	4.01E-08	2.82E-08	0.	0.	0.	2.33E-21
SR89	3.08E-04	0.	8.84E-06	0.	0.	0.	4.94E-05
SR90	7.58E-03	0.	1.86E-03	0.	0.	0.	2.19E-04
SR91	5.67E-06	0.	2.29E-07	0.	0.	0.	2.70E-05
SR92	2.15E-06	0.	9.30E-08	0.	0.	0.	4.26E-05

INGESTION DOSE COMMITMENT FACTORS

ADULT INGESTION DOSE COMMITMENT FACTORS (MREM/50Y PER PCI INGESTED IN FIRST YR)

ISOTOPE	BONE	LIVER	TOTAL BODY	THYROID	KIDNEY	LUNG	GI-LLI
Y90	9.62E-09	0.	2.58E-10	0.	0.	0.	1.02E-04
Y91M	9.09E-11	0.	3.52E-12	0.	0.	0.	2.67E-10
Y91	1.41E-07	0.	3.77E-09	0.	0.	0.	7.76E-05
Y92	8.45E-10	0.	2.47E-11	0.	0.	0.	1.48E-05
Y93	2.68E-09	0.	7.40E-11	0.	0.	0.	8.50E-05
ZR93	4.18E-08	2.34E-09	1.09E-09	0.	8.87E-09	0.	2.43E-06
ZR95	3.04E-08	9.75E-09	6.60E-09	0.	1.53E-08	0.	3.09E-05
ZR97	1.68E-09	3.39E-10	1.55E-10	0.	5.12E-10	0.	1.05E-04
NB93M	2.55E-08	8.32E-09	2.05E-09	0.	9.57E-09	0.	3.84E-06
NB95	6.22E-09	3.46E-09	1.86E-09	0.	3.42E-09	0.	2.10E-05
NB97	5.22E-11	1.32E-11	4.82E-12	0.	1.54E-11	0.	4.87E-08
MO93	0.	7.51E-06	2.03E-07	0.	2.13E-06	0.	1.22E-06
MO99	0.	4.31E-06	8.20E-07	0.	9.76E-06	0.	9.99E-06
TC99M	2.47E-10	6.98E-10	8.89E-09	0.	1.06E-08	3.42E-10	4.13E-07
TC99	1.25E-07	1.86E-07	5.02E-08	0.	2.34E-06	1.58E-08	6.08E-06
TC101	2.54E-10	3.66E-10	3.59E-09	0.	6.59E-09	1.87E-10	1.10E-21
RU103	1.85E-07	0.	7.97E-08	0.	7.06E-07	0.	2.16E-05
RU105	1.54E-08	0.	6.08E-09	0.	1.99E-07	0.	9.42E-06
RU106	2.75E-06	0.	3.48E-07	0.	5.31E-06	0.	1.78E-04
RH105	1.21E-07	8.85E-08	5.83E-08	0.	3.76E-07	0.	1.41E-05
PD107	0.	1.47E-07	9.40E-09	0.	1.32E-06	0.	9.11E-07
PD109	0.	1.77E-07	3.99E-08	0.	1.01E-06	0.	1.96E-05
AG110M	1.60E-07	1.48E-07	8.79E-08	0.	2.91E-07	0.	6.04E-05
AG111	5.81E-08	2.43E-08	1.21E-08	0.	7.84E-08	0.	4.46E-05
CD113M	0.	3.18E-06	1.02E-07	0.	3.50E-06	0.	2.56E-05
CD115M	0.	1.84E-06	5.87E-08	0.	1.46E-06	0.	7.74E-05
SN123	3.11E-05	5.15E-07	7.59E-07	4.38E-07	0.	0.	6.33E-05
SN125	8.33E-06	1.68E-07	3.78E-07	1.39E-07	0.	0.	1.04E-04
SN126	8.45E-05	1.67E-06	2.40E-06	4.92E-07	0.	0.	2.43E-05
SB124	2.80E-06	5.29E-08	1.11E-06	6.79E-09	0.	2.18E-06	7.95E-05
SB125	1.79E-06	2.00E-08	4.26E-07	1.82E-09	0.	1.38E-06	1.97E-05
SB126	1.15E-06	2.34E-08	4.15E-07	7.04E-09	0.	7.05E-07	9.40E-05
SB127	2.58E-07	5.65E-09	9.90E-08	3.10E-09	0.	1.53E-07	5.90E-05
TE125M	2.68E-06	9.71E-07	3.59E-07	8.06E-07	1.09E-05	0.	1.07E-05
TE125M	6.77E-06	2.42E-06	8.25E-07	1.73E-06	2.75E-05	0.	2.27E-05
TE127	1.10E-07	3.95E-08	2.38E-08	8.15E-08	4.48E-07	0.	8.68E-06
TE129M	1.15E-05	4.29E-06	1.82E-06	3.95E-06	4.80E-05	0.	5.79E-05
TE129	3.14E-08	1.18E-08	7.65E-09	2.41E-08	1.32E-07	0.	2.37E-08
TE131M	1.73E-06	8.46E-07	7.05E-07	1.34E-06	8.57E-06	0.	8.40E-05
TE131	1.97E-08	8.23E-09	6.22E-09	1.62E-08	8.63E-08	0.	2.79E-09
TE132	2.52E-06	1.63E-06	1.53E-06	1.80E-06	1.57E-05	0.	7.71E-05
TE133M	4.62E-08	2.70E-08	2.60E-08	3.91E-08	2.67E-07	0.	6.64E-08
TE134	3.24E-08	2.12E-08	1.30E-08	2.83E-08	2.05E-07	0.	3.59E-11
I129	3.27E-06	2.81E-06	9.21E-06	7.23E-03	6.04E-06	0.	4.44E-07
I130	7.56E-07	2.23E-06	8.80E-07	1.89E-04	3.48E-06	0.	1.92E-06
I131	4.16E-06	5.95E-06	3.41E-06	1.95E-03	1.02E-05	0.	1.57E-06

INGESTION DOSE COMMITMENT FACTORS

ADULT INGESTION DOSE COMMITMENT FACTORS (MREM/50Y PER PCI INGESTED IN FIRST YR)

ISOTOPE	BONE	LIVER	TOTAL BODY	THYROID	KIDNEY	LUNG	GI-LLI
I132	2.03E-07	5.43E-07	1.90E-07	1.90E-05	8.65E-07	0.	1.02E-07
I133	1.42E-06	2.47E-06	7.53E-07	3.63E-04	4.31E-06	0.	2.22E-06
I134	1.06E-07	2.88E-07	1.03E-07	4.99E-06	4.58E-07	0.	2.51E-10
I135	4.43E-07	1.16E-06	4.28E-07	7.65E-05	1.86E-06	0.	1.31E-06
XE131M	0.	0.	0.	0.	0.	0.	0.
XE133M	0.	0.	0.	0.	0.	0.	0.
XE133	0.	0.	0.	0.	0.	0.	0.
XE135M	0.	0.	0.	0.	0.	0.	0.
XE135	0.	0.	0.	0.	0.	0.	0.
XE137	0.	0.	0.	0.	0.	0.	0.
XE138	0.	0.	0.	0.	0.	0.	0.
CS134M	2.13E-08	4.48E-08	2.29E-08	0.	2.43E-08	3.83E-09	1.58E-08
CS134	6.22E-05	1.48E-04	1.21E-04	0.	4.79E-05	1.59E-05	2.59E-06
CS135	1.95E-05	1.80E-05	7.99E-06	0.	6.81E-06	2.04E-06	4.21E-07
CS136	6.51E-06	2.57E-05	1.85E-05	0.	1.43E-05	1.96E-06	2.92E-06
CS137	7.97E-05	1.09E-04	7.14E-05	0.	3.70E-05	1.23E-05	2.11E-06
CS138	6.52E-08	1.09E-07	5.40E-08	0.	8.01E-08	7.91E-09	4.65E-13
CS139	3.41E-08	5.08E-08	1.85E-08	0.	4.07E-08	3.70E-09	1.10E-30
BA139	9.70E-08	6.91E-11	2.84E-09	0.	6.46E-11	3.92E-11	1.72E-07
BA140	2.03E-05	2.55E-08	1.33E-06	0.	8.67E-09	1.46E-08	4.18E-05
BA141	4.71E-08	3.56E-11	1.59E-09	0.	3.31E-11	2.02E-11	2.22E-17
BA142	2.13E-08	2.19E-11	1.34E-09	0.	1.85E-11	1.24E-11	3.00E-26
LA140	2.50E-09	1.26E-09	3.33E-10	0.	0.	0.	9.25E-05
LA141	3.19E-10	9.90E-11	1.62E-11	0.	0.	0.	1.18E-05
LA142	1.28E-10	5.82E-11	1.45E-11	0.	0.	0.	4.25E-07
CE141	9.36E-09	6.33E-09	7.18E-10	0.	2.94E-09	0.	2.42E-05
CE143	1.65E-09	1.22E-06	1.35E-10	0.	5.37E-10	0.	4.56E-05
CE144	4.88E-07	2.04E-07	2.62E-08	0.	1.21E-07	0.	1.65E-04
PR143	9.20E-09	3.69E-09	4.56E-10	0.	2.13E-09	0.	4.03E-05
PR144	3.01E-11	1.25E-11	1.53E-12	0.	7.05E-12	0.	4.33E-18
ND147	6.29E-09	7.27E-09	4.35E-10	0.	4.25E-09	0.	3.49E-05
PM147	7.54E-08	7.09E-09	2.87E-09	0.	1.34E-08	0.	8.93E-06
PM148M	3.07E-08	7.95E-09	6.08E-09	0.	1.20E-08	0.	6.74E-05
PM148	7.17E-09	1.19E-09	5.99E-10	0.	2.25E-09	0.	9.35E-05
PM149	1.52E-09	2.15E-10	8.78E-11	0.	4.06E-10	0.	4.03E-05
PM151	6.97E-10	1.17E-10	5.91E-11	0.	2.09E-10	0.	3.22E-05
SM151	6.90E-08	1.19E-08	2.85E-09	0.	1.33E-08	0.	5.25E-06
SM153	8.57E-10	7.15E-10	5.22E-11	0.	2.31E-10	0.	2.55E-05
EU152	1.95E-07	4.44E-08	3.90E-08	0.	2.75E-07	0.	2.56E-05
EU154	6.15E-07	7.56E-08	5.38E-08	0.	3.62E-07	0.	5.48E-05
EU155	8.60E-08	1.22E-08	7.87E-09	0.	5.63E-08	0.	9.60E-06
EU156	1.37E-08	1.06E-08	1.71E-09	0.	7.08E-09	0.	7.26E-05
TB160	4.70E-08	0.	5.86E-09	0.	1.94E-08	0.	4.33E-05
HO166M	2.70E-07	8.43E-08	6.40E-08	0.	1.26E-07	0.	0.
W181	9.91E-09	3.23E-09	3.46E-10	0.	0.	0.	3.68E-07
W185	4.05E-07	1.35E-07	1.42E-08	0.	0.	0.	1.56E-05
W187	1.03E-07	8.61E-08	3.01E-08	0.	0.	0.	2.82E-05

INGESTION DOSE COMMITMENT FACTORS

ADULT INGESTION DOSE COMMITMENT FACTORS (MREM/50Y PER PCI INGESTED IN FIRST YR)

ISOTOPE	BONE	LIVER	TOTAL BODY	THYROID	KIDNEY	LUNG	GI-LLI
PB210	1.53E-02	4.37E-03	5.44E-04	0.	1.23E-02	0.	5.42E-05
BI210	4.61E-07	3.18E-06	3.96E-08	0.	3.83E-05	0.	4.75E-05
PO210	3.56E-04	7.56E-04	8.59E-05	0.	2.52E-03	0.	6.36E-05
RN222	0.	0.	0.	0.	0.	0.	0.
RA223	4.97E-03	7.65E-06	9.94E-04	0.	2.17E-04	0.	3.21E-04
RA224	1.61E-03	3.90E-06	3.23E-04	0.	1.10E-04	0.	3.40E-04
RA225	6.56E-03	7.78E-06	1.31E-03	0.	2.21E-04	0.	3.06E-04
RA226	3.02E-01	5.74E-06	2.20E-01	0.	1.63E-04	0.	3.32E-04
RA228	1.12E-01	3.12E-06	1.21E-01	0.	8.83E-05	0.	5.64E-05
AC225	4.40E-06	6.06E-06	2.96E-07	0.	6.90E-07	0.	4.07E-04
AC227	1.87E-03	2.48E-04	1.11E-04	0.	8.00E-05	0.	8.19E-05
TH227	1.37E-05	2.48E-07	3.95E-07	0.	1.41E-06	0.	5.40E-04
TH228	4.96E-04	8.40E-06	1.68E-05	0.	4.67E-05	0.	5.63E-04
TH229	7.98E-03	1.19E-04	3.91E-04	0.	5.75E-04	0.	5.12E-04
TH230	2.06E-03	1.17E-04	5.70E-05	0.	5.65E-04	0.	6.02E-05
TH232	2.30E-03	1.00E-04	1.50E-04	0.	4.82E-04	0.	5.12E-05
TH234	8.01E-08	4.71E-09	2.31E-09	0.	2.67E-08	0.	1.13E-04
PA231	4.10E-03	1.54E-04	1.59E-04	0.	8.64E-04	0.	7.17E-05
PA233	5.26E-09	1.06E-09	9.12E-10	0.	3.99E-09	0.	1.64E-05
U232	4.13E-03	0.	2.95E-04	0.	4.47E-04	0.	6.78E-05
U233	8.71E-04	0.	5.28E-05	0.	2.03E-04	0.	6.27E-05
U234	8.36E-04	0.	5.17E-05	0.	1.99E-04	0.	6.14E-05
U235	8.01E-04	0.	4.86E-05	0.	1.87E-04	0.	7.81E-05
U236	8.01E-04	0.	4.96E-05	0.	1.91E-04	0.	5.76E-05
U237	5.52E-8	0.	1.47E-08	0.	2.27E-07	0.	1.94E-05
U238	7.67E-04	0.	4.54E-05	0.	1.75E-04	0.	5.50E-05
NP237	1.37E-03	1.19E-04	5.54E-05	0.	4.12E-04	0.	7.94E-05
NP238	1.37E-08	3.69E-10	2.13E-10	0.	1.25E-09	0.	3.43E-05
NP239	1.19E-09	1.17E-10	6.45E-11	0.	3.65E-10	0.	2.40E-05
PU238	6.80E-04	9.58E-05	1.71E-05	0.	7.32E-05	0.	7.30E-05
PU239	7.87E-04	1.06E-04	1.91E-05	0.	8.11E-05	0.	6.66E-05
PU240	7.85E-04	1.06E-04	1.91E-05	0.	8.10E-05	0.	6.78E-05
PU241	1.65E-05	8.44E-07	3.32E-07	0.	1.53E-06	0.	1.40E-06
PU242	7.29E-04	1.02E-04	1.84E-05	0.	7.81E-05	0.	6.53E-05
PU244	8.52E-04	1.17E-04	2.11E-05	0.	8.95E-05	0.	9.73E-05
AM241	8.19E-04	2.88E-04	5.41E-05	0.	4.07E-04	0.	7.42E-05
AM242M	8.24E-04	2.78E-04	5.43E-05	0.	4.05E-04	0.	9.34E-05
AM243	8.18E-04	2.78E-04	5.30E-05	0.	3.99E-04	0.	8.70E-05
CM242	2.06E-05	2.10E-05	1.37E-06	0.	6.22E-06	0.	7.92E-05
CM243	6.39E-04	2.41E-04	3.75E-05	0.	1.75E-04	0.	7.81E-05
CM244	4.83E-04	2.07E-04	2.87E-05	0.	1.34E-04	0.	7.55E-05
CM245	1.02E-03	2.87E-04	5.76E-05	0.	2.69E-04	0.	7.04E-05
CM246	1.01E-03	2.87E-04	5.75E-05	0.	2.68E-04	0.	6.91E-05
CM247	9.84E-04	2.83E-04	5.67E-05	0.	2.64E-04	0.	9.09E-05
CM248	8.18E-03	2.33E-03	4.67E-04	0.	2.18E-03	0.	1.47E-03
CF252	2.64E-04	0.	6.29E-06	0.	0.	0.	2.88E-04

ENCLOSURE 2
PALISADES NUCLEAR PLANT
JOINT FREQUENCY TABLES MET DATA

32 Pages Follow

SITE: Palisades

Hours at each Wind Speed and Direction

Period of Record: 1/1/13 - 3/31/13

Stability Class: A

Elevation: Speed: SP10M Direction: DIR10M Lapse: DT50M

Wind Direction	Wind Speed (MPH)						Total
	1-3	4-7	8-12	13-18	19-24	>24	
N			3				3
NNE							0
NE							0
ENE							0
E							0
ESE		1	2				3
SE	1						1
SSE	1	5	3	1			10
S		4	7	2			13
SSW		2					2
SW	1	3					4
WSW		14	2				16
W		2					2
WNW		7	4				11
NW		4	6	1			11
NNW			4	3			7
Total	3	42	31	7			83

Periods of Calm (hours): 0

Variable direction: 0

Hours of Missing Data: 0

Hours are not adjusted for Daylight Savings Time.

SITE: Palisades

Hours at each Wind Speed and Direction

Period of Record: 1/1/13 - 3/31/13

Stability Class: B

Elevation: Speed: SP10M Direction: DIR10M Lapse: DT50M

Wind Direction	Wind Speed (MPH)						Total
	1-3	4-7	8-12	13-18	19-24	>24	
N		1	3				4
NNE		1					1
NE		1					1
ENE							0
E		1		3			4
ESE			3				3
SE		2					2
SSE		1	2				3
S		3	2	1			6
SSW		3					3
SW			1				1
WSW		2	3				5
W		5					5
WNW		8	2	3			13
NW		7	7	2			16
NNW			8	1			9
Total	0	35	31	10	0	0	76

Periods of Calm (hours): 0

Variable direction: 0

Hours of Missing Data: 0

Hours are not adjusted for Daylight Savings Time.

SITE: Palisades

Hours at each Wind Speed and Direction

Period of Record: 1/1/13 - 3/31/13

Stability Class: C

Elevation: Speed: SP10M Direction: DIR10M Lapse: DT50M

Wind Direction	Wind Speed (MPH)						Total
	1-3	4-7	8-12	13-18	19-24	>24	
N			2				2
NNE		2	1	1			4
NE		1	1				2
ENE		1		2			3
E			1				1
ESE			2				2
SE		2	2	1	1		6
SSE		1	5	1			7
S	1	3	3				7
SSW			2				2
SW	1	1	4				6
WSW		2	4				6
W	1	4		1	2		8
WNW		5	6				11
NW		6	12	4			22
NNW		8	11	4			23
Total	3	36	56	14	3		112

Periods of Calm (hours): 0

Variable direction: 0

Hours of Missing Data: 0

Hours are not adjusted for Daylight Savings Time.

SITE: Palisades

Hours at each Wind Speed and Direction

Period of Record: 1/1/13 - 3/31/13

Stability Class: D

Elevation: Speed: SP10M Direction: DIR10M Lapse: DT50M

Wind Direction	Wind Speed (MPH)						Total
	1-3	4-7	8-12	13-18	19-24	>24	
N	2	19	45	1			67
NNE	2	36	19	2			59
NE	7	26	14	2			49
ENE		18	13	2			33
E	2	10	20	15	3		50
ESE	3	6	13	18			40
SE	1	20	37	31	3		92
SSE	5	27	36	19	5		92
S	2	23	14				39
SSW		12	10				22
SW	3	16	45	11			75
WSW	5	14	68	24			111
W	4	20	55	37	3		119
WNW	4	34	110	64	3		215
NW	5	49	143	64	1		262
NNW	7	21	67	19	2		116
Total	52	351	709	309	20		1441

Periods of Calm (hours): 3

Variable direction: 0

Hours of Missing Data: 0

Hours are not adjusted for Daylight Savings Time.

SITE: Palisades

Hours at each Wind Speed and Direction

Period of Record: 1/1/13 - 3/31/13

Stability Class: E

Elevation: Speed: SP10M Direction: DIR10M Lapse: DT50M

Wind Direction	Wind Speed (MPH)						Total
	1-3	4-7	8-12	13-18	19-24	>24	
N	1	4					5
NNE	3	8					11
NE	2	9	1				12
ENE	3	12	4				19
E	1	13	3	1			18
ESE	2	5	1	1			9
SE	2	17	18	4			41
SSE	3	23	28	13			67
S	3	41	18				62
SSW	2	13	9				24
SW	1	9	5	1			16
WSW		5	5	1			11
W		7	8				15
WNW	1	7	2				10
NW	2	9	1				12
NNW	1	6	1				8
Total	27	188	104	21			340

Periods of Calm (hours): 1

Variable direction: 0

Hours of Missing Data: 0

Hours are not adjusted for Daylight Savings Time.

SITE: Palisades

Hours at each Wind Speed and Direction

Period of Record: 1/1/13 - 3/31/13

Stability Class: F

Elevation: Speed: SP10M Direction: DIR10M Lapse: DT50M

Wind Direction	Wind Speed (MPH)						Total
	1-3	4-7	8-12	13-18	19-24	>24	
N	1	2					3
NNE							0
NE	2	1					3
ENE	1	5					6
E	2	1					3
ESE	4	3					7
SE	5	8					13
SSE		19	1				20
S	1	5					6
SSW	1	1	1				3
SW	1						1
WSW							0
W	1						1
WNW	1						1
NW	2						2
NNW							0
Total	22	45	2				69

Periods of Calm (hours): 1

Variable direction: 0

Hours of Missing Data: 0

Hours are not adjusted for Daylight Savings Time.

SITE: Palisades

Hours at each Wind Speed and Direction

Period of Record: 1/1/13 - 3/31/13

Stability Class: G

Elevation: Speed: SP10M Direction: DIR10M Lapse: DT50M

Wind Direction	Wind Speed (MPH)						Total
	1-3	4-7	8-12	13-18	19-24	>24	
N							0
NNE	1						1
NE							0
ENE							0
E	1						1
ESE	1	2					3
SE	2	8					10
SSE	1	8					9
S	2	6					8
SSW	1						1
SW							0
WSW							0
W	1						1
WNW							0
NW							0
NNW							0
Total	10	24					34

Periods of Calm (hours): 0

Variable direction: 0

Hours of Missing Data: 0

Hours are not adjusted for Daylight Savings Time.

SITE: Palisades

Hours at each Wind Speed and Direction

Period of Record: 1/1/13 - 3/31/13
Stability Class: All
Elevation: Speed: SP10M Direction: DIR10M Lapse: DT50M

Wind Direction	Wind Speed (MPH)						Total
	1-3	4-7	8-12	13-18	19-24	>24	
N	4	26	53	1			84
NNE	6	47	20	3			76
NE	11	38	16	2			67
ENE	4	36	17	4			61
E	6	25	24	19	3		77
ESE	10	17	21	19			67
SE	11	57	57	36	4		165
SSE	10	84	75	34	5		208
S	9	85	44	3			141
SSW	4	31	22				57
SW	7	29	55	12			103
WSW	5	37	82	25			149
W	7	38	63	38	5		151
WNW	6	61	124	67	3		261
NW	9	75	169	71	1		325
NNW	8	35	91	27	2		163
Total	117	721	933	361	23		2155

Periods of Calm (hours): 5
Variable direction: 0
Hours of Missing Data: 0

Hours are not adjusted for Daylight Savings Time.

SITE: Palisades

Hours at each Wind Speed and Direction

Period of Record: 4/1/13 - 6/30/13

Stability Class: A

Elevation: Speed: SP10M Direction: DIR10M Lapse: DT50M

Wind Direction	Wind Speed (MPH)						Total
	1-3	4-7	8-12	13-18	19-24	>24	
N		2	5				7
NNE	2	1	1				4
NE	2	3	1				6
ENE	1	6		1			8
E			3				3
ESE		3	5	5			13
SE	1	4	16	2	1		24
SSE		8	18	8	1		35
S		11	9				20
SSW		4	3				7
SW		6	6				12
WSW	4	16	12				32
W		23		3			26
WNW	4	31	6				41
NW	3	56	22	1			82
NNW	2	20	31	5			58
Total	19	194	138	25	2		378

Periods of Calm (hours): 0

Variable direction: 0

Hours of Missing Data: 0

Hours are not adjusted for Daylight Savings Time.

SITE: Palisades

Hours at each Wind Speed and Direction

Period of Record: 4/1/13 - 6/30/13

Stability Class: B

Elevation: Speed: SP10M Direction: DIR10M Lapse: DT50M

Wind Direction	Wind Speed (MPH)						Total
	1-3	4-7	8-12	13-18	19-24	>24	
N		2	2				4
NNE			1				1
NE		1	1				2
ENE	1	1	1				3
E			1				1
ESE		1		3			4
SE		2	8	3			13
SSE		1	5	1	1		8
S		2	4				6
SSW	2	2					4
SW		6	2				8
WSW		9					9
W		3	1	2			6
WNW	2	1	1				4
NW		12	7				19
NNW		6	7	1			14
Total	5	49	41	10	1	0	106

Periods of Calm (hours): 0

Variable direction: 0

Hours of Missing Data: 0

Hours are not adjusted for Daylight Savings Time.

SITE: Palisades

Hours at each Wind Speed and Direction

Period of Record: 4/1/13 - 6/30/13

Stability Class: C

Elevation: Speed: SP10M Direction: DIR10M Lapse: DT50M

Wind Direction	Wind Speed (MPH)						Total
	1-3	4-7	8-12	13-18	19-24	>24	
N		5	1				6
NNE		1					1
NE		2					2
ENE	1	1	1				3
E		1					1
ESE	1	2	3	2			8
SE		1	6	2			9
SSE		5	4	2	4		15
S		1	6				7
SSW		3					3
SW		3	2				5
WSW	1	4		2			7
W	1	2	1	2			6
WNW	1	1	2	1			5
NW	3	6	4				13
NNW		5	5	4			14
Total	8	43	35	15	4		105

Periods of Calm (hours): 0

Variable direction: 0

Hours of Missing Data: 0

Hours are not adjusted for Daylight Savings Time.

SITE: Palisades

Hours at each Wind Speed and Direction

Period of Record: 4/1/13 - 6/30/13

Stability Class: D

Elevation: Speed: SP10M Direction: DIR10M Lapse: DT50M

Wind Direction	Wind Speed (MPH)						Total
	1-3	4-7	8-12	13-18	19-24	>24	
N	2	17	5				24
NNE	2	9	4				15
NE	2	3	2				7
ENE	3	16	11	2			32
E	1	4	12	16	2		35
ESE	4	12	14	10	4		44
SE	1	10	34	25	5		75
SSE		20	32	8	2		62
S	3	24	11				38
SSW	3	10	1	1			15
SW	8	22	20				50
WSW	4	25	13	17			59
W	10	16	14	5			45
WNW	12	8	7	2			29
NW	7	25	10	9			51
NNW	3	49	29	18			99
Total	65	270	219	113	13		680

Periods of Calm (hours): 2

Variable direction: 0

Hours of Missing Data: 0

Hours are not adjusted for Daylight Savings Time.

SITE: Palisades

Hours at each Wind Speed and Direction

Period of Record: 4/1/13 - 6/30/13

Stability Class: E

Elevation: Speed: SP10M Direction: DIR10M Lapse: DT50M

Wind Direction	Wind Speed (MPH)						Total
	1-3	4-7	8-12	13-18	19-24	>24	
N	5	16	3				24
NNE	4	14	1				19
NE	5	15					20
ENE	2	10	3				15
E	9	11	9	5			34
ESE	6	20	13				39
SE	5	27	49	18	2		101
SSE	5	33	45	6	1		90
S	5	27	4				36
SSW	7	13	2				22
SW	3	30	6	5			44
WSW	3	16	5	1			25
W	11	9	1	1			22
WNW	8	1	1				10
NW	9	11					20
NNW	10	18	5				33
Total	97	271	147	36	3		554

Periods of Calm (hours): 0

Variable direction: 0

Hours of Missing Data: 0

Hours are not adjusted for Daylight Savings Time.

SITE: Palisades

Hours at each Wind Speed and Direction

Period of Record: 4/1/13 - 6/30/13

Stability Class: F

Elevation: Speed: SP10M Direction: DIR10M Lapse: DT50M

Wind Direction	Wind Speed (MPH)						Total
	1-3	4-7	8-12	13-18	19-24	>24	
N	2	7	1				10
NNE	1	3					4
NE	2	4					6
ENE	3	10					13
E	6	7	3				16
ESE	2	10	1				13
SE	1	10	8				19
SSE	5	22					27
S	6	17					23
SSW	3	4					7
SW	4	2					6
WSW	7						7
W	4	1					5
WNW	3						3
NW	4	1					5
NNW	3	6	1				10
Total	56	104	14				174

Periods of Calm (hours): 0

Variable direction: 0

Hours of Missing Data: 0

Hours are not adjusted for Daylight Savings Time.

SITE: Palisades

Hours at each Wind Speed and Direction

Period of Record: 4/1/13 - 6/30/13

Stability Class: G

Elevation: Speed: SP10M Direction: DIR10M Lapse: DT50M

Wind Direction	Wind Speed (MPH)						Total
	<u>1-3</u>	<u>4-7</u>	<u>8-12</u>	<u>13-18</u>	<u>19-24</u>	>24	
N	1	3					4
NNE	1	3					4
NE	3	1					4
ENE	5	12	3				20
E	5	13					18
ESE	5	10					15
SE	3	14	1				18
SSE	4	19	1				24
S	5	16					21
SSW	2	3					5
SW	5	1					6
WSW	2						2
W	4						4
WNW	2	2					4
NW	5						5
NNW	2	2					4
Total	54	99	5				158

Periods of Calm (hours): 1
Variable direction: 0
Hours of Missing Data: 0

Hours are not adjusted for Daylight Savings Time.

SITE: Palisades

Hours at each Wind Speed and Direction

Period of Record: 4/1/13 - 6/30/13

Stability Class: All

Elevation: Speed: SP10M Direction: DIR10M Lapse: DT50M

Wind Direction	Wind Speed (MPH)						Total
	1-3	4-7	8-12	13-18	19-24	>24	
N	10	52	17				79
NNE	10	31	7				48
NE	14	29	4				47
ENE	16	56	19	3			94
E	21	36	28	21	2		108
ESE	18	58	36	20	4		136
SE	11	68	122	50	8		259
SSE	14	108	105	25	9		261
S	19	98	34				151
SSW	17	39	6	1			63
SW	20	70	36	5			131
WSW	21	70	30	20			141
W	30	54	17	13			114
WNW	32	44	17	3			96
NW	31	111	43	10			195
NNW	20	106	78	28			232
Total	304	1030	599	199	23		2155

Periods of Calm (hours): 3
Variable direction: 0
Hours of Missing Data: 26

Hours are not adjusted for Daylight Savings Time.

SITE: Palisades

Hours at each Wind Speed and Direction

Period of Record: 7/1/13 - 9/30/13

Stability Class: A

Elevation: Speed: SP10M Direction: DIR10M Lapse: DT50M

Wind Direction	Wind Speed (MPH)						Total
	1-3	4-7	8-12	13-18	19-24	>24	
N		14	5				19
NNE		3					3
NE		4					4
ENE	1	13					14
E		10					10
ESE	2	12	13				27
SE	2	21	19				42
SSE		11	8				19
S	2	1					3
SSW	2	2					4
SW	2	10	4				16
WSW	4	24					28
W	4	20					24
WNW	5	25					30
NW	2	48	2				52
NNW	1	69	34	3			107
Total	27	287	85	3			402

Periods of Calm (hours): 0

Variable direction: 0

Hours of Missing Data: 0

Hours are not adjusted for Daylight Savings Time.

SITE: Palisades

Hours at each Wind Speed and Direction

Period of Record: 7/1/13 - 9/30/13

Stability Class: B

Elevation: Speed: SP10M Direction: DIR10M Lapse: DT50M

Wind Direction	Wind Speed (MPH)						Total
	1-3	4-7	8-12	13-18	19-24	>24	
N		1	1				2
NNE	1	2					3
NE		2	1				3
ENE		2					2
E							0
ESE		3					3
SE		5	2				7
SSE		2	1				3
S		3					3
SSW		1					1
SW		11	6				17
WSW		6	1				7
W	2	6					8
WNW	2	2	1				5
NW	2	6	1				9
NNW		11	3				14
Total	7	63	17	0	0	0	87

Periods of Calm (hours): 0

Variable direction: 0

Hours of Missing Data: 0

Hours are not adjusted for Daylight Savings Time.

SITE: Palisades

Hours at each Wind Speed and Direction

Period of Record: 7/1/13 - 9/30/13

Stability Class: C

Elevation: Speed: SP10M Direction: DIR10M Lapse: DT50M

Wind Direction	Wind Speed (MPH)						Total
	1-3	4-7	8-12	13-18	19-24	>24	
N		2	3				5
NNE		3					3
NE							0
ENE			2				2
E		1					1
ESE		3	1	1			5
SE		2	3				5
SSE	1	3					4
S		1					1
SSW	1	1					2
SW	1	22	1				24
WSW	2	7					9
W	2	3					5
WNW	2	4					6
NW	3	3					6
NNW		11	3	1			15
Total	12	66	13	2			93

Periods of Calm (hours): 0

Variable direction: 0

Hours of Missing Data: 0

Hours are not adjusted for Daylight Savings Time.

SITE: Palisades

Hours at each Wind Speed and Direction

Period of Record: 7/1/13 - 9/30/13

Stability Class: D

Elevation: Speed: SP10M Direction: DIR10M Lapse: DT50M

Wind Direction	Wind Speed (MPH)						Total
	1-3	4-7	8-12	13-18	19-24	>24	
N	4	21	7				32
NNE	2	13	2				17
NE	2	8					10
ENE	2	9	2	1			14
E	2	11	2				15
ESE	1	9	8				18
SE	4	13	12				29
SSE	2	21	7				30
S	9	8					17
SSW	2	14					16
SW	14	55	16				85
WSW	17	14					31
W	11	10	4				25
WNW	3	9	3				15
NW	14	17	7				38
NNW	3	56	23	1			83
Total	92	288	93	2			475

Periods of Calm (hours): 0

Variable direction: 0

Hours of Missing Data: 0

Hours are not adjusted for Daylight Savings Time.

SITE: Palisades

Hours at each Wind Speed and Direction

Period of Record: 7/1/13 - 9/30/13

Stability Class: E

Elevation: Speed: SP10M Direction: DIR10M Lapse: DT50M

Wind Direction	Wind Speed (MPH)						Total
	1-3	4-7	8-12	13-18	19-24	>24	
N	17	58	6				81
NNE	8	12	1				21
NE	14	2	1				17
ENE	9	19	1				29
E	8	11	1				20
ESE	6	23	3				32
SE	10	16	20				46
SSE	6	24	10	1			41
S	23	31					54
SSW	6	14					20
SW	11	37	38				86
WSW	7	30	4				41
W	8	15	3				26
WNW	2	10	1				13
NW	8	5	1				14
NNW	13	34	3				50
Total	156	341	93	1			591

Periods of Calm (hours): 2

Variable direction: 0

Hours of Missing Data: 0

Hours are not adjusted for Daylight Savings Time.

SITE: Palisades

Hours at each Wind Speed and Direction

Period of Record: 7/1/13 - 9/30/13

Stability Class: F

Elevation: Speed: SP10M Direction: DIR10M Lapse:DT50M

Wind Direction	Wind Speed (MPH)						Total
	1-3	4-7	8-12	13-18	19-24	>24	
N	8	10					18
NNE	9	5					14
NE	10	3					13
ENE	12	17					29
E	5	10					15
ESE	6	18	1				25
SE	8	24	5				37
SSE	14	22	1				37
S	23	21					44
SSW	9	15					24
SW	4	2					6
WSW	2						2
W	2						2
WNW							0
NW	3						3
NNW	7						7
Total	122	147	7				276

Periods of Calm (hours): 2

Variable direction: 0

Hours of Missing Data: 0

Hours are not adjusted for Daylight Savings Time.

SITE: Palisades

Hours at each Wind Speed and Direction

Period of Record: 7/1/13 - 9/30/13

Stability Class: G

Elevation: Speed: SP10M Direction: DIR10M Lapse: DT50M

Wind Speed (MPH)

<u>Wind Direction</u>	<u>1-3</u>	<u>4-7</u>	<u>8-12</u>	<u>13-18</u>	<u>19-24</u>	<u>>24</u>	<u>Total</u>
N	3	1					4
NNE							0
NE	8	3					11
ENE	8	8					16
E	5	22					27
ESE	12	30					42
SE	2	37					39
SSE	14	45					59
S	13	54					67
SSW	2	10					12
SW	1	1					2
WSW							0
W							0
WNW							0
NW							0
NNW							0
Total	68	211					279

Periods of Calm (hours): 0

Variable direction: 0

Hours of Missing Data: 0

Hours are not adjusted for Daylight Savings Time.

SITE: Palisades

Hours at each Wind Speed and Direction

Period of Record: 7/1/13 - 9/30/13

Stability Class: All

Elevation: Speed: SP10M Direction: DIR10M Lapse: DT50M

Wind Direction	Wind Speed (MPH)						Total
	1-3	4-7	8-12	13-18	19-24	>24	
N	32	107	22				161
NNE	20	38	3				61
NE	34	22	2				58
ENE	32	68	5	1			106
E	20	65	3				88
ESE	27	98	26	1			152
SE	26	118	61				205
SSE	37	128	27	1			193
S	70	119					189
SSW	22	57					79
SW	33	138	65				236
WSW	32	81	5				118
W	29	54	7				90
WNW	14	50	5				69
NW	32	79	11				122
NNW	24	181	66	5			276
Total	484	1403	308	8			2203

Periods of Calm (hours): 4

Variable direction: 0

Hours of Missing Data: 1

Hours are not adjusted for Daylight Savings Time.

SITE: Palisades

Hours at each Wind Speed and Direction

Period of Record: 10/1/13 - 12/31/13

Stability Class: A

Elevation: Speed: SP10M Direction: DIR10M Lapse: DT50M

Wind Direction	Wind Speed (MPH)						Total
	1-3	4-7	8-12	13-18	19-24	>24	
N	1						1
NNE							0
NE	1						1
ENE		3					3
E		2	1				3
ESE		3	1				4
SE		6	4				10
SSE		7	4				11
S	1	5	3				9
SSW		3					3
SW	1	6					7
WSW		2	5				7
W		6	1				7
WNW	1	2					3
NW	2	10	5				17
NNW		3					3
Total	7	58	24				89

Periods of Calm (hours): 0

Variable direction: 0

Hours of Missing Data: 0

Hours are not adjusted for Daylight Savings Time.

SITE: Palisades

Hours at each Wind Speed and Direction

Period of Record: 10/1/13 - 12/31/13
Stability Class: B
Elevation: Speed: SP10M Direction: DIR10M Lapse: DT50M

Wind Direction	Wind Speed (MPH)						Total
	1-3	4-7	8-12	13-18	19-24	>24	
N							0
NNE		1					1
NE							0
ENE		1					1
E			2				2
ESE			1				1
SE	2	1	1	1			5
SSE	1	4	1	2			8
S	2	2	1				5
SSW		5					5
SW		3	2				5
WSW		5	4				9
W		5	1		1		7
WNW		3	2				5
NW		2	5				7
NNW		5					5
Total	5	37	20	3	1	0	66

Periods of Calm (hours): 0
Variable direction: 0
Hours of Missing Data: 0

Hours are not adjusted for Daylight Savings Time.

SITE: Palisades

Hours at each Wind Speed and Direction

Period of Record: 10/1/13 - 12/31/13

Stability Class: C

Elevation: Speed: SP10M Direction: DIR10M Lapse: DT50M

Wind Direction	Wind Speed (MPH)						Total
	1-3	4-7	8-12	13-18	19-24	>24	
N							0
NNE							0
NE		1					1
ENE		3					3
E		1					1
ESE			2				2
SE	1	3	9	1			14
SSE		6	4	3			13
S		9	2				11
SSW		2	4				6
SW	1	7	2				10
WSW		5	2				7
W	1	4	3				8
WNW	1	4					5
NW			1				1
NNW		2	1	1			4
Total	4	47	30	5			86

Periods of Calm (hours): 0

Variable direction: 0

Hours of Missing Data: 0

Hours are not adjusted for Daylight Savings Time.

SITE: Palisades

Hours at each Wind Speed and Direction

Period of Record: 10/1/13 - 12/31/13
Stability Class: D
Elevation: Speed: SP10M Direction: DIR10M Lapse: DT50M

Wind Direction	Wind Speed (MPH)						Total
	1-3	4-7	8-12	13-18	19-24	>24	
N	2	5	7	1			15
NNE	2	12	7				21
NE	5	14					19
ENE	5	17	8				30
E	4	10	10	6			30
ESE	3	10	8	12			33
SE	1	22	45	11			79
SSE	2	50	62	22	1		137
S	3	71	10				84
SSW	3	36	11				50
SW	6	24	27	8			65
WSW	2	10	58	6			76
W	3	34	129	42	3		211
WNW	1	23	130	22			176
NW		42	106	19			167
NNW	1	28	39	41	1		110
Total	43	408	657	190	5		1303

Periods of Calm (hours): 2
Variable direction: 0
Hours of Missing Data: 13

Hours are not adjusted for Daylight Savings Time.

SITE: Palisades

Hours at each Wind Speed and Direction

Period of Record: 10/1/13 - 12/31/13
Stability Class: E
Elevation: Speed: SP10M Direction: DIR10M Lapse: DT50M

Wind Direction	Wind Speed (MPH)						Total
	1-3	4-7	8-12	13-18	19-24	>24	
N	1	10					11
NNE	2	12	1				15
NE	4	3					7
ENE	2	8	1				11
E	2	11	6				19
ESE	3	21	4				28
SE	4	35	20				59
SSE	2	79	21				102
S	6	48	7				61
SSW	2	29	16				47
SW		17	24	1			42
WSW	1	7	5				13
W	2	13	9				24
WNW	1	10	3				14
NW	4	6	8				18
NNW	1	7	3				11
Total	37	316	128	1			482

Periods of Calm (hours): 1
Variable direction: 0
Hours of Missing Data: 0

Hours are not adjusted for Daylight Savings Time.

SITE: Palisades

Hours at each Wind Speed and Direction

Period of Record: 10/1/13 - 12/31/13
Stability Class: F
Elevation: Speed: SP10M Direction: DIR10M Lapse: DT50M

Wind Direction	Wind Speed (MPH)						Total
	1-3	4-7	8-12	13-18	19-24	>24	
N	1	2					3
NNE		1					1
NE		4					4
ENE		1					1
E		3					3
ESE	2	3	2				7
SE	1	18	3				22
SSE	3	20	10				33
S	2	15					17
SSW		3					3
SW		2					2
WSW							0
W							0
WNW							0
NW							0
NNW	2						2
Total	11	72	15				98

Periods of Calm (hours): 0
Variable direction: 0
Hours of Missing Data: 0

Hours are not adjusted for Daylight Savings Time.

SITE: Palisades

Hours at each Wind Speed and Direction

Period of Record: 10/1/13 - 12/31/13
Stability Class: G
Elevation: Speed: SP10M Direction: DIR10M Lapse: DT50M

Wind Direction	Wind Speed (MPH)						Total
	<u>1-3</u>	<u>4-7</u>	<u>8-12</u>	<u>13-18</u>	<u>19-24</u>	>24	
N							0
NNE		1					1
NE		2					2
ENE	2	5					7
E	2	2					4
ESE		7	1				8
SE		30					30
SSE		13	1				14
S		2					2
SSW							0
SW							0
WSW							0
W							0
WNW							0
NW							0
NNW							0
Total	4	62	2				68

Periods of Calm (hours): 0
Variable direction: 0
Hours of Missing Data: 0

Hours are not adjusted for Daylight Savings Time.

SITE: Palisades

Hours at each Wind Speed and Direction

Period of Record: 10/1/13 - 12/31/13
Stability Class: All
Elevation: Speed: SP10M Direction: DIR10M Lapse: DT50M

Wind Direction	Wind Speed (MPH)						Total
	1-3	4-7	8-12	13-18	19-24	>24	
N	5	17	7	1			30
NNE	4	27	8				39
NE	10	24					34
ENE	9	38	9				56
E	8	29	19	6			62
ESE	8	44	19	12			83
SE	9	115	82	13			219
SSE	8	179	103	27	1		318
S	14	152	23				189
SSW	5	78	31				114
SW	8	59	55	9			131
WSW	3	29	74	6			112
W	6	62	143	42	4		257
WNW	4	42	135	22			203
NW	6	60	125	19			210
NNW	4	45	43	42	1		135
Total	111	1000	876	199	6		2192

Periods of Calm (hours): 3
Variable direction: 0
Hours of Missing Data: 13

Hours are not adjusted for Daylight Savings Time.

ATTACHMENT 2
BIG ROCK POINT INDEPENDENT SPENT FUEL STORAGE INSTALLATION
2013 RADIOACTIVE EFFLUENT RELEASE REPORT

This report provides information relating to radioactive effluent releases and solid radioactive waste disposal at Big Rock Point (BRP) for the year 2013. The report format is detailed in the BRP Offsite Dose Calculation Manual (ODCM). Effluent releases from BRP are controlled by the Defueled Technical Specifications and the ODCM requirements. The ODCM was not revised in 2013.

2013 Operating History

On January 8, 2007, the Nuclear Regulatory Commission (NRC) approved release of the former BRP nuclear plant property for unrestricted use in accordance with the BRP License Termination Plan¹. On April 11, 2007, the license for BRP, DPR-06, was transferred to Entergy Nuclear Operations, Inc.

During 2013, normal independent spent fuel storage installation (ISFSI) operations continued. There were no operational activities that generated any solid radioactive waste.

Liquid and gaseous effluent monitoring is no longer conducted as the former BRP nuclear plant property has been released from the license. Short-lived radionuclides, including iodine and noble gas, are neither expected nor reported.

1. Supplemental Information

A. Batch Releases

There were no batch releases of gaseous or liquid effluents during 2013. All batch releases of radioactive liquids as described in the ODCM ceased in 2004.

B. Abnormal Releases

There were no abnormal releases from BRP during 2013.

C. Radioactive Effluent Monitoring Instrumentation

BRP ODCM currently specifies required actions when less than the minimum number of radioactive effluent monitoring instrument channels are operable. The ODCM also specifies these actions be taken when installed effluent monitoring systems are removed from service for decommissioning.

All plant-installed liquid and gaseous radioactive effluent monitoring instrument channels have been permanently removed and dismantled.

¹ Letter from the USNRC dated January 8, 2007, "Release of Land from Part 50 License for Unrestricted Use"

2. Gaseous Effluents

Although there were no gaseous effluents released during 2013, Table 2 provides a summary of all gaseous radioactive effluent monitoring conducted during the reporting period as required by the ODCM.

3. Liquid Effluents

There were no liquid effluent batch releases during 2013. Table 3 lists and summarizes liquid effluent releases in accordance with the ODCM.

4. Solid Waste

There was no solid radioactive waste generated or shipped during 2013.

5. Summary of Radiological Impact on Man

The ODCM specifies that the annual effluent release report provide potential dose calculations based on measured effluent to liquid and gaseous pathways, if estimates of dose exceed one millirem to an organ or total body of any individual or more than one person-rem to the population within 50 miles. During 2013, there were no releases. Therefore, no calculations were required.

6. Offsite Dose Calculation Manual

The ODCM describes the radiological release requirements for the BRP site. There were no revisions to the ODCM in 2013.

7. Process Control Program (PCP)

The Process Control Program (PCP) describes solid waste processing and disposal methods utilized at the BRP site. The PCP was not revised during 2013.

TABLE 1
Big Rock Point
Batch Releases
 January 1, 2013 to December 31, 2013

A. GASEOUS

B. LIQUID	Units	1ST QTR	2ND QTR	3RD QTR	4TH QTR
Number of Releases		N/A	N/A	N/A	N/A
Total Release Time	Minutes	N/A	N/A	N/A	N/A
Maximum Release Time	Minutes	N/A	N/A	N/A	N/A
Average Release Time	Minutes	N/A	N/A	N/A	N/A
Minimum Release Time	Minutes	N/A	N/A	N/A	N/A

TABLE 2
Big Rock Point
Gaseous Effluent Releases
 January 1, 2013 to December 31, 2013

A. FISSION AND ACTIVATION GASES	Units	1ST QTR	2ND QTR	3RD QTR	4TH QTR	Est Total Error %
1. Total release	Ci	N/A	N/A	N/A	N/A	N/A
2. Average release rate for period	µCi/sec	N/A	N/A	N/A	N/A	
3. Percent of annual avg EC	%	N/A	N/A	N/A	N/A	

B. IODINES	Units	1ST QTR	2ND QTR	3RD QTR	4TH QTR	Est Total Error %
1. Total iodine	Ci	N/A	N/A	N/A	N/A	N/A
2. Average release rate for period	µCi/sec	N/A	N/A	N/A	N/A	
3. Percent of annual avg EC	%	N/A	N/A	N/A	N/A	

C. PARTICULATES	Units	1ST QTR	2ND QTR	3RD QTR	4TH QTR	Est Total Error %
1. Particulates with half-life >8 day	Ci	N/A	N/A	N/A	N/A	N/A
2. Average release rate for period	µCi/sec	N/A	N/A	N/A	N/A	
3. Percent of annual avg EC	%	N/A	N/A	N/A	N/A	
4. Gross alpha radioactivity	Ci	N/A	N/A	N/A	N/A	

D. TRITIUM	Units	1ST QTR	2ND QTR	3RD QTR	4TH QTR	Est Total Error %
1. Total Release	Ci	N/A	N/A	N/A	N/A	N/A
2. Average release rate for period	µCi/sec	N/A	N/A	N/A	N/A	
3. Percent of annual avg EC	%	N/A	N/A	N/A	N/A	

E. WHOLE BODY DOSE	Units	1ST QTR	2ND QTR	3RD QTR	4TH QTR	Est Total Error %
1. Beta Air dose at Site Boundary due to Noble Gases (ODCM Section 1, 1.3.2 a (1) (2))	mrad	N/A	N/A	N/A	N/A	N/A
2. Percent limit	%	N/A	N/A	N/A	N/A	
3. Gamma Air dose at Site Boundary due to Noble Gas (ODCM Section 1, 1.3.2 a (1) (2))	mrad	N/A	N/A	N/A	N/A	
4. Percent limit	%	N/A	N/A	N/A	N/A	

F. ORGAN DOSE (ODCM Section 1, 1.3.2b (1) (2))	Units	1ST QTR	2ND QTR	3RD QTR	4TH QTR	Est Total Error %
1. Maximum organ dose to public based on Critical Receptors (child bone)	mrem	N/A	N/A	N/A	N/A	N/A
2. Percent of limit (7.5 mrem/quarter)	%	N/A	N/A	N/A	N/A	

TABLE 2
Big Rock Point
Gaseous Effluent Releases
 January 1, 2013 to December 31, 2013

1. FISSION GASES	Units	1ST QTR	2ND QTR	3RD QTR	4TH QTR
Krypton-85m	Ci	N/A	N/A	N/A	N/A
Krypton-87	Ci	N/A	N/A	N/A	N/A
Krypton-88	Ci	N/A	N/A	N/A	N/A
Xenon-133	Ci	N/A	N/A	N/A	N/A
Xenon-133m	Ci	N/A	N/A	N/A	N/A
Xenon-135	Ci	N/A	N/A	N/A	N/A
Xenon-135m	Ci	N/A	N/A	N/A	N/A
Xenon-138	Ci	N/A	N/A	N/A	N/A
Total for Period	Ci	N/A	N/A	N/A	N/A

2. IODINES					
Iodine-131	Ci	N/A	N/A	N/A	N/A
Iodine-132	Ci	N/A	N/A	N/A	N/A
Iodine-133	Ci	N/A	N/A	N/A	N/A
Iodine-134	Ci	N/A	N/A	N/A	N/A
Iodine-135	Ci	N/A	N/A	N/A	N/A
Total for Period	Ci	N/A	N/A	N/A	N/A

TABLE 2
Big Rock Point
Gaseous Effluent Releases
January 1, 2013 to December 31, 2013

3. PARTICULATES*	Units	1ST QTR	2ND QTR	3RD QTR	4TH QTR
Chromium-51	Ci	N/A	N/A	N/A	N/A
Manganese-54	Ci	N/A	N/A	N/A	N/A
Cobalt-58	Ci	N/A	N/A	N/A	N/A
Iron-59	Ci	N/A	N/A	N/A	N/A
Cobalt-60	Ci	N/A	N/A	N/A	N/A
Zinc-65	Ci	N/A	N/A	N/A	N/A
Silver-110m	Ci	N/A	N/A	N/A	N/A
Cesium-134	Ci	N/A	N/A	N/A	N/A
Cesium-137	Ci	N/A	N/A	N/A	N/A
Barium-140	Ci	N/A	N/A	N/A	N/A
Europium-152	Ci	N/A	N/A	N/A	N/A
Strontium-89	Ci	N/A	N/A	N/A	N/A
Strontium-90	Ci	N/A	N/A	N/A	N/A
Net unidentified beta	Ci	N/A	N/A	N/A	N/A
Total	Ci	N/A	N/A	N/A	N/A

* Particulates with half-life >8 days

TABLE 3
Big Rock Point
Liquid Effluent Releases
 January 1, 2013 to December 31, 2013

A. FISSION AND ACTIVATION PRODUCTS	Units	1ST QTR	2ND QTR	3RD QTR	4TH QTR	Est Total Error %
1. Total release (not including tritium, gases, alpha)	Ci	N/A	N/A	N/A	N/A	N/A
2. Average diluted concentration during period	µCi/ml	N/A	N/A	N/A	N/A	
3. Percent of EC	%	N/A	N/A	N/A	N/A	

B. TRITIUM	Units	1ST QTR	2ND QTR	3RD QTR	4TH QTR	Est Total Error %
1. Total release	Ci	N/A	N/A	N/A	N/A	N/A
2. Average diluted concentration during period	µCi/ml	N/A	N/A	N/A	N/A	
3. Percent of EC	%	N/A	N/A	N/A	N/A	

C. DISSOLVED AND ENTRAINED GASES	Units	1ST QTR	2ND QTR	3RD QTR	4TH QTR	Est Total Error %
1. Total release	Ci	N/A	N/A	N/A	N/A	N/A
2. Average diluted concentration during period	µCi/ml	N/A	N/A	N/A	N/A	
3. Percent of EC	%	N/A	N/A	N/A	N/A	

D. GROSS ALPHA RADIOACTIVITY	Units	1ST QTR	2ND QTR	3RD QTR	4TH QTR
	Ci	N/A	N/A	N/A	N/A

E. VOLUME OF WASTE RELEASED (Prior to dilution)	Units	1ST QTR	2ND QTR	3RD QTR	4TH QTR
	Liters	N/A	N/A	N/A	N/A

F. VOLUME OF DILUTION WATER USED DURING PERIOD	Units	1ST QTR	2ND QTR	3RD QTR	4TH QTR
	Liters	N/A	N/A	N/A	N/A

G. MAXIMUM DOSE COMMITMENT WHOLEBODY	Units	1ST QTR	2ND QTR	3RD QTR	4TH QTR
	mrem	N/A	N/A	N/A	N/A
Percent of ODCM Section 1, 2.3.2 a (1.5 mrem)	%	N/A	N/A	N/A	N/A

H. MAXIMUM DOSE COMMITMENT – ORGAN	Units	1ST QTR	2ND QTR	3RD QTR	4TH QTR
	Mrem	N/A	N/A	N/A	N/A
Percent of ODCM Section 1, 2.3.2 b (3.0 mrem)	%	N/A	N/A	N/A	N/A

TABLE 3
Big Rock Point
Liquid Effluent Releases
January 1, 2013 to December 31, 2013

1. NUCLIDES RELEASED	Units	1ST QTR	2ND QTR	3RD QTR	4TH QTR
Chromium-51	Ci	--	--	--	--
Manganese 54	Ci	--	--	--	--
Cobalt-58	Ci	--	--	--	--
Iron-59	Ci	--	--	--	--
Cobalt-60	Ci	--	--	--	--
Zinc-65	Ci	--	--	--	--
Strontium-89	Ci	--	--	--	--
Strontium-90	Ci	--	--	--	--
Molybdenum-99	Ci	--	--	--	--
Silver-110m	Ci	--	--	--	--
Iodine-131	Ci	--	--	--	--
Cesium-134	Ci	--	--	--	--
Cesium-137	Ci	--	--	--	--
Antimony-125	Ci	--	--	--	--
Tin-113	Ci	--	--	--	--
Net Unidentified Beta	Ci	--	--	--	--
Fission & Activation Product Total	Ci	--	--	--	--
Xenon-133	Ci	--	--	--	--
Tritium	Ci	--	--	--	--
Grand Total	Ci	--	--	--	--