

Draft Waste Incidental to Reprocessing Evaluation for Vitrified Low-Activity Waste Disposed Onsite at the Hanford Site, Washington

Prepared for the U.S. Department of Energy
Assistant Secretary for Environmental Management



**P.O. Box 450
Richland, Washington 99352**

Draft Waste Incidental to Reprocessing Evaluation for Vitrified Low-Activity Waste Disposed Onsite at the Hanford Site, Washington

Date Published
April 2020

Prepared for the U.S. Department of Energy
Assistant Secretary for Environmental Management

Office of River Protection

P.O. Box 450
Richland, Washington 99352

APPROVED

By Lynn M. Ayers at 11:10 am, Apr 23, 2020

Release Approval

Date

TRADEMARK DISCLAIMER

Reference herein to any specific commercial product, process, or service by tradename, trademark, manufacturer, or otherwise, does not necessarily constitute or imply its endorsement, recommendation, or favoring by the United States Government or any agency thereof or its contractors or subcontractors.

This report has been reproduced from the best available copy.

Printed in the United States of America



Draft
Waste Incidental to Reprocessing
Evaluation
For
Vitrified Low-Activity Waste
Disposed Onsite at the
Hanford Site, Washington

Office of River Protection
U.S. Department of Energy

April 2020

This page intentionally left blank.

TABLE OF CONTENTS

| | | |
|-------|--|------|
| 1.0 | INTRODUCTION | 1-1 |
| 1.1 | PURPOSE AND WASTE INCIDENTAL TO REPROCESSING CRITERIA | 1-3 |
| 1.2 | SCOPE | 1-3 |
| 1.3 | BACKGROUND AND OVERVIEW OF DIRECT-FEED LOW- ACTIVITY WASTE APPROACH..... | 1-4 |
| 1.4 | CONSULTATION AND OPPORTUNITY FOR PUBLIC REVIEW..... | 1-6 |
| 1.5 | ORGANIZATION OF THIS DRAFT WIR EVALUATION | 1-7 |
| 2.0 | BACKGROUND | 2-1 |
| 2.1 | HANFORD HISTORY | 2-1 |
| 2.2 | HANFORD SITE AND INTEGRATED DISPOSAL FACILITY CHARACTERISTICS | 2-2 |
| 2.2.1 | Hanford Site | 2-2 |
| 2.2.2 | Meteorology and Climatology | 2-6 |
| 2.2.3 | Geology, Seismology, and Volcanology | 2-14 |
| 2.2.4 | Hanford Site Geologic Framework | 2-24 |
| 2.2.5 | Integrated Disposal Facility Geologic Framework | 2-29 |
| 2.2.6 | Hydrology | 2-33 |
| 2.2.7 | Groundwater | 2-38 |
| 2.3 | RADIOACTIVITY IN THE UNDERGROUND WASTE STORAGE TANKS | 2-46 |
| 2.4 | TANK WASTE RETRIEVAL, TREATMENT, AND DISPOSAL PLAN | 2-49 |
| 2.5 | HANFORD TANK WASTE TREATMENT AND IMMOBILIZATION PLANT..... | 2-51 |
| 2.5.1 | Background..... | 2-51 |
| 2.5.2 | Tank 241-AP-106..... | 2-60 |
| 2.5.3 | The Low-Activity Waste Vitrification Facility..... | 2-62 |
| 2.5.4 | Estimated Volume and Characteristics of the Vitrified Low-Activity Waste..... | 2-63 |
| 2.6 | THE INTEGRATED DISPOSAL FACILITY | 2-64 |

| | | |
|-------|--|------|
| 3.0 | WASTE DETERMINATION CRITERIA | 3-1 |
| 4.0 | THE WASTE WILL BE PROCESSED TO REMOVE KEY RADIONUCLIDES TO THE MAXIMUM EXTENT THAT IS TECHNICALLY AND ECONOMICALLY PRACTICAL | 4-1 |
| 4.1 | KEY RADIONUCLIDES..... | 4-1 |
| 4.1.1 | Introduction..... | 4-1 |
| 4.1.2 | U.S. Department of Energy Guidance on Identification of Key Radionuclides..... | 4-2 |
| 4.1.3 | U.S. Nuclear Regulatory Commission 10 CFR 61.55 Requirements | 4-2 |
| 4.1.4 | Radionuclides Important to the Integrated Disposal Facility Performance Assessment | 4-3 |
| 4.1.5 | Inadvertent Intruder Performance Measure | 4-4 |
| 4.1.6 | Summary of Key Radionuclides in the Vitrified Low-Activity Waste.... | 4-4 |
| 4.2 | REMOVAL TO THE MAXIMUM EXTENT TECHNICALLY AND ECONOMICALLY PRACTICAL | 4-6 |
| 4.2.1 | Introduction..... | 4-6 |
| 4.2.2 | Technical Practicality Assessment..... | 4-7 |
| 4.2.3 | Economic Practicality Assessment | 4-15 |
| 4.3 | CONCLUSIONS ON KEY RADIONUCLIDE REMOVAL | 4-18 |
| 5.0 | THE WASTE WILL BE MANAGED TO MEET SAFETY REQUIREMENTS COMPARABLE TO THE PERFORMANCE OBJECTIVES OF 10 CFR Part 61, SUBPART C..... | 5-1 |
| 5.1 | INTRODUCTION | 5-1 |
| 5.2 | U.S. DEPARTMENT OF ENERGY SAFETY REQUIREMENTS | 5-1 |
| 5.2.1 | General Safety Requirement..... | 5-4 |
| 5.2.2 | Protection of the General Population from Releases of Radioactivity | 5-5 |
| 5.2.3 | Estimated Impact of Disposal at Integrated Disposal Facility..... | 5-10 |
| 5.2.4 | Protection of Individuals from Inadvertent Intrusion | 5-14 |
| 5.2.5 | Protection of Individuals During Operations..... | 5-17 |
| 5.2.6 | Air Emissions Limit for Individual Member of the Public [NRC 10 CFR 20.1101(d); DOE O 458.1, Admin Chg 3]..... | 5-20 |
| 5.2.7 | Total Effective Dose Equivalent Limit for Adult Workers [NRC 10 CFR 20.1201(a)(1)(i); DOE 10 CFR 835.202(a)(1)]..... | 5-21 |
| 5.2.8 | Any Individual Organ or Tissue Dose Limit for Adult Workers [NRC 10 CFR 20.1201(a)(1)(ii); DOE 10 CFR 835.202(a)(2)] | 5-21 |
| 5.2.9 | Annual Dose Limit to the Lens of the Eye for Adult Workers [NRC 10 CFR 20.1201(a)(2)(i); DOE 10 CFR 835.202(a)(3)]..... | 5-22 |

| | | |
|--------|---|------|
| 5.2.10 | Annual Dose Limit to the Skin of the Whole Body and to the Skin of the Extremities for Adult Workers [NRC 10 CFR 20.1201(a)(2)(ii); DOE 10 CFR 835.202(a)(4)] | 5-22 |
| 5.2.11 | Dose Equivalent to an Embryo/Fetus [NRC 10 CFR 20.1208(a); DOE 10 CFR 835.206(a)] | 5-22 |
| 5.2.12 | Total Effective Dose Equivalent Limit for Individual Members of the Public [NRC 10 CFR 20.1301(a)(1); DOE O 458.1, Admin Chg 3] | 5-23 |
| 5.2.13 | Dose Limits for Individual Members of the Public in Unrestricted Areas [NRC 10 CFR 20.1301(a)(2); DOE 10 CFR 835.602 and 603] .. | 5-23 |
| 5.2.14 | Dose Limits for Individual Members of the Public in Controlled Areas [NRC 10 CFR 20.1301(b); DOE 10 CFR 835.208] | 5-24 |
| 5.2.15 | As Low As Reasonably Achievable (NRC 10 CFR 20.1003; DOE 10 CFR 835.2)..... | 5-24 |
| 5.2.16 | Conclusion for Radiation Protection..... | 5-26 |
| 5.3 | STABILITY OF THE DISPOSAL SITE AFTER CLOSURE..... | 5-27 |
| 5.4 | INTEGRATED DISPOSAL FACILITY POST-CLOSURE ALARA..... | 5-29 |
| 5.5 | INTEGRATED DISPOSAL FACILITY PERFORMANCE ASSESSMENT MAINTENANCE | 5-29 |
| 6.0 | THE WASTE DOES NOT EXCEED CLASS C CONCENTRATION LIMITS AND WILL BE MANAGED IN ACCORDANCE WITH U.S. DEPARTMENT OF ENERGY REQUIREMENTS AS LOW-LEVEL WASTE | 6-1 |
| 6.1 | SOLID PHYSICAL FORMS..... | 6-1 |
| 6.1.1 | Vitrified Glass..... | 6-1 |
| 6.2 | RADIONUCLIDE CONCENTRATION LESS THAN CLASS C LIMITS | 6-2 |
| 6.2.1 | Class C Limit Requirements | 6-2 |
| 6.3 | CONCLUSIONS ON SOLID PHYSICAL FORM AND CLASS C | 6-5 |
| 7.0 | CONCLUSION..... | 7-1 |
| 8.0 | REFERENCES | 8-1 |

FIGURES

| | |
|--|------|
| Figure 1-1. Hanford Site Map..... | 1-4 |
| Figure 2-1. U.S. Department of Energy’s Hanford Site and Surrounding Area..... | 2-3 |
| Figure 2-2. Key Facilities in the 200 East and 200 West Areas of the Hanford Site. | 2-5 |
| Figure 2-3. Generalized Land Use of the Hanford Site and Adjacent Areas..... | 2-7 |
| Figure 2-4. Hanford Meteorological Monitoring Network Wind Roses in 2010 at the 9.1-meter (30-foot) Level..... | 2-9 |
| Figure 2-5. Hanford Meteorological Monitoring Network Wind Roses from 1982 to 2006 at the 9.1-meter (30-foot) Level..... | 2-13 |
| Figure 2-6. Geologic Elements of the Pasco Basin Portion of the Columbia Basin, Washington. | 2-16 |
| Figure 2-7. Geologic Setting of the Columbia Basin and Pasco Basin. | 2-17 |
| Figure 2-8. Historical Earthquake Activity of the Columbia Basin, Washington, and Surrounding Areas. | 2-20 |
| Figure 2-9. Map Showing the Location of Earthquakes Detected Since 1969 near the Integrated Disposal Facility Site..... | 2-21 |
| Figure 2-10. Earthquake Swarm Areas Near the Hanford Site..... | 2-22 |
| Figure 2-11. Geologic Structures of the Pasco Basin and Vicinity. | 2-25 |
| Figure 2-12. Geologic and Geomorphic Map of the 200 Areas and Vicinity..... | 2-26 |
| Figure 2-13. Surface Water Features including Rivers, Ponds, Major Springs, and Ephemeral Streams on the Hanford Site, Washington..... | 2-34 |
| Figure 2-14. Probable Maximum Flood Area on the Hanford Site as Determined by the Upper Limit of Precipitation and Maximum Runoff. | 2-37 |
| Figure 2-15. Probable Maximum Flood Area in Cold Creek Area, Hanford Site Delineated Using the U.S. Army Corps of Engineers’ HEC-2 Water Surface Profiles Model. | 2-39 |
| Figure 2-16. Central Plateau Groundwater Contaminant Plumes in 2015 and Remediation. .. | 2-42 |
| Figure 2-17. 200 East Area Groundwater Contaminant Plumes in 2015. | 2-43 |
| Figure 2-18. 200-PO Well Locations..... | 2-45 |
| Figure 2-19. Hanford Site Map Showing Different Areas..... | 2-49 |
| Figure 2-20. Hanford Site Components in the Direct-Feed Low-Activity Waste Approach. .. | 2-52 |
| Figure 2-21. Process Flowsheet for Direct-Feed Low-Activity Waste Operations. | 2-55 |
| Figure 2-22. Tank-Side Cesium Removal Location East of 241-AP Tank Farm..... | 2-58 |
| Figure 2-23. Tank-Side Cesium Removal System Concept Diagram. | 2-59 |
| Figure 2-24. Simplified Tank 241-AP-106 Repurposing Strategy. | 2-61 |

| | |
|---|------|
| Figure 2-25. Vitrified Low-Activity Waste Container. | 2-63 |
| Figure 4-1. Tank Waste Form Volumes and Estimated Total Activity in the Underground Waste Tanks. | 4-8 |
| Figure 4-2. Tank-Side Cesium Removal System..... | 4-10 |
| Figure 5-1. General Process Used to Ensure Performance Objectives Are Achieved..... | 5-3 |
| Figure 5-2. Radon-222 Flux vs. Time After Integrated Disposal Facility Closure. | 5-8 |
| Figure 5-3. All-Pathways Dose vs. Time After Integrated Disposal Facility Closure. | 5-10 |
| Figure 5-4. Groundwater Pathway Dose by Isotope..... | 5-11 |
| Figure 5-5. Statistical Stability Analysis – Comparison of Realizations to the Mean and 50 th Percentile Groundwater Pathway Dose. | 5-12 |
| Figure 5-6. Uncertainty Analysis – Comparison of Realizations for the Groundwater Pathway Dose. | 5-13 |
| Figure 5-7. Uncertainty Analysis – Comparison of Mean Annual Groundwater Pathway for Different Waste Streams. | 5-14 |
| Figure 5-8. Well Driller Dose vs. Time After First Receipt at Integrated Disposal Facility.... | 5-15 |
| Figure 5-9. Rural Pasture Dose vs. Time After First Receipt at Integrated Disposal Facility.. | 5-16 |

TABLES

| | |
|--|------|
| Table 2-1. Monthly and Average Annual Temperatures at Hanford Meteorological Station since 2000 (°C). | 2-10 |
| Table 2-2. Monthly and Average Annual Precipitation at Hanford Meteorological Station since 2000 (cm). | 2-11 |
| Table 2-3. Estimated Total Radioactivity in 177 Underground Waste Tanks (Ci). | 2-48 |
| Table 2-4. Currently Planned Sequence of Direct-Feed Low-Activity Waste Campaigns. (2 sheets) | 2-56 |
| Table 4-1. Long-Lived Radionuclides. | 4-2 |
| Table 4-2. Short-Lived Radionuclides..... | 4-3 |
| Table 4-3. Key Radionuclides. (2 sheets) | 4-4 |
| Table 4-4. Direct-Feed Low-Activity Waste Campaign Cesium Decontamination Factors. ... | 4-11 |
| Table 4-5. Percentages of Total Curies Removed by Tank-Side Cesium Removal Operation. | 4-13 |
| Table 4-6. Percentages of Cesium-137 Removed by Tank-Side Cesium Removal in Direct-Feed Low-Activity Waste Campaigns..... | 4-14 |
| Table 4-7. Summary of Costs for Technically Practical Radionuclide Removal Technology Options..... | 4-16 |

| | |
|---|------|
| Table 4-8. Comparison of DFLAW Pretreatment Approaches | 4-17 |
| Table 5-1. Integrated Disposal Facility Performance Assessment Acute and Chronic Inadvertent Intruder Scenarios..... | 5-4 |
| Table 5-2. Integrated Disposal Facility Estimated Peak Dose Following an Inadvertent Intrusion. | 5-17 |
| Table 5-3. Crosswalk Between Applicable 10 CFR Part 20 Standards and U.S. Department of Energy Requirements. | 5-19 |
| Table 6-1. Summary of Vitrified Low-Activity Waste Glass Sum of Fractions for each Direct-Feed Low-Activity Waste Campaign..... | 6-3 |
| Table 6-2. Direct-Feed Low-Activity Waste Vitrified Low-Activity Waste Glass Maximum Sum of Fractions for 10 CFR 61.55 Table 1 Radionuclides. | 6-4 |
| Table 6-3. Direct-Feed Low-Activity Waste Vitrified Low-Activity Waste Glass Maximum Sum of Fractions for 10 CFR 61.55 Table 2 Radionuclides. | 6-5 |

LIST OF APPENDICES

- A COMPARISON OF U.S. DEPARTMENT OF ENERGY AND U.S. NUCLEAR REGULATORY COMMISSION LOW-LEVEL WASTE DISPOSAL PERFORMANCE OBJECTIVES AND PERFORMANCE MEASURES
- B COMPARABILITY OF U.S. DEPARTMENT OF ENERGY AND U.S. NUCLEAR REGULATORY COMMISSION DOSE STANDARDS DURING OPERATIONS
- C CONSIDERATION OF THE CRITERIA IN SECTION 3116 OF THE RONALD W. REAGAN NATIONAL DEFENSE AUTHORIZATION ACT FOR FISCAL YEAR 2005
- D U.S. NUCLEAR REGULATORY COMMISSION AND HANFORD INTERACTION HISTORY
- E REPURPOSING OF DOUBLE-SHELL TANK 241-AP-106 AS LOW-ACTIVITY WASTE FEED TANK
- F COMPARISON OF LOW-ACTIVITY WASTE PRETREATMENT SYSTEM PRIOR APPROACH AND DIRECT-FEED LOW-ACTIVITY WASTE APPROACH TO FILTRATION

ABBREVIATIONS AND ACRONYMS

| | |
|---------|--|
| AEA | <i>Atomic Energy Act of 1954</i> |
| ALARA | as low as reasonably achievable |
| Am | americium |
| Ba | barium |
| BBI | Best-Basis Inventory |
| bgs | below ground surface |
| BPP | Bismuth Phosphate Process |
| CA | composite analysis |
| CCU | Cold Creek Unit |
| CERCLA | <i>Comprehensive Environmental Response, Compensation, and Liability Act</i> |
| CFR | <i>Code of Federal Regulations</i> |
| Chg | change |
| CHPRC | CH2M HILL Plateau Remediation Company |
| Cm | curium |
| CNWRA | Center for Nuclear Waste Regulatory Analyses |
| Co | cobalt |
| COPC | constituent of potential concern |
| CRBG | Columbia River Basalt Group |
| Cs | cesium |
| CST | crystalline silicotitanate |
| DEF | dead-end filter |
| DF | decontamination factor |
| DFLAW | Direct-Feed Low-Activity Waste |
| DOE | U.S. Department of Energy |
| DOE G | DOE Guide |
| DOE-HQ | U.S. Department of Energy-Headquarters |
| DOE M | DOE Manual |
| DOE O | DOE Order |
| DST | double-shell tank |
| Ecology | State of Washington Department of Ecology |
| EMF | Effluent Management Facility |
| EPA | U.S. Environmental Protection Agency |
| ERDF | Environmental Restoration Disposal Facility |
| ETF | Effluent Treatment Facility |
| FFTF | Fast Flux Test Facility |
| H | hydrogen |
| HD | high density |
| HDW | Hanford Defined Wastes |

| | |
|--------|---|
| HEPA | high-efficiency particulate air |
| HFFACO | <i>Hanford Federal Facility Agreement and Consent Order</i> |
| HLW | high-level radioactive waste |
| HMS | Hanford Meteorological Station |
| I | iodine |
| IDF | Integrated Disposal Facility |
| ILAW | immobilized low-activity waste (synonymous with VLAW) |
| IX | ion exchange |
| LAW | low-activity waste or Low-Activity Waste Vitrification Facility |
| LAWPS | Low-Activity Waste Pretreatment System |
| LDR | Land Disposal Restrictions |
| LERF | Liquid Effluent Retention Facility |
| LFRG | Low-Level Waste Disposal Facility Federal Review Group |
| LLW | low-level radioactive waste |
| MCL | maximum contaminant level |
| MLLW | mixed low-level radioactive waste |
| MMI | Modified Mercalli Intensity |
| Ni | nickel |
| Np | neptunium |
| NRC | U.S. Nuclear Regulatory Commission |
| OU | operable unit |
| ORP | DOE Office of River Protection |
| PA | Performance Assessment |
| PCB | polychlorinated biphenyl |
| PFP | Plutonium Finishing Plant |
| PNNL | Pacific Northwest National Laboratory |
| PTF | Pretreatment Facility |
| Pu | plutonium |
| PUREX | plutonium uranium extraction |
| RBA | radiological buffer area |
| RCRA | <i>Resource Conservation and Recovery Act of 1976</i> |
| REDOX | reduction and oxidation [process] |
| RL | DOE Richland Operations Office |
| Rn | radon |
| SBS | submerged bed scrubber |
| SDWA | <i>Safe Drinking Water Act of 1974</i> |
| SNF | spent nuclear fuel |
| Sr | strontium |
| sRF | spherical resorcinol-formaldehyde |
| SST | single-shell tank |
| SSW | secondary solid waste |

| | |
|-----------|--|
| TBR | WHC-SD-WM-TI-699, <i>Technical Basis for Classification of Low-Activity Waste Fraction from Hanford Site Tanks</i> |
| Tc | technetium |
| TC&WM EIS | Tank Closure and Waste Management Environmental Impact Statement |
| TED | total effective dose |
| TFPT | Tank Farms Pretreatment |
| TPA | Tri-Party Agreement |
| TRU | Transuranic |
| TRUEX | transuranic extraction (process) |
| TSCR | Tank-Side Cesium Removal |
| U | uranium |
| U.S. | United States |
| VLAW | vitrified low-activity waste (synonymous with ILAW) |
| WAC | <i>Washington Administrative Code</i> |
| WESP | wet electrostatic precipitator |
| WIR | Waste Incidental to Reprocessing |
| WMA | Waste Management Area |
| WTP | Hanford Tank Waste Treatment and Immobilization Plant; Waste Treatment Plant |
| Y | yttrium |

UNITS

| | |
|--------------------|---------------------------------|
| % | percent |
| μ | micron |
| μg | microgram |
| $^{\circ}\text{C}$ | degrees Celsius |
| $^{\circ}\text{F}$ | degrees Fahrenheit |
| Bq | becquerel |
| Ci | curie |
| cm | centimeter, 10^{-2} meter |
| cm^3 | cubic centimeter |
| d | day |
| ft | foot or feet |
| ft^2 | square foot |
| ft^3 | cubic foot |
| g | gram [mass] |
| g | gravitational acceleration |
| gal | gallon |
| gpm | gallons per minute |
| h | hour |
| in. | inch |
| kg | kilogram, 10^3 grams |
| kgal | kilogallons |
| km | kilometer |
| L | liter |
| m | meter |
| Ma | million years ago |
| m/m | meter per meter |
| m^2 | square meter |
| m^3 | cubic meter |
| MCi | million curies, 10^6 curie |
| mg | milligram, 10^{-3} grams |
| Mgal | million gallons, 10^6 gallon |
| mi | mile |
| mi^2 | square mile |
| millirem | 10^{-3} rem |
| mL | milliliter |
| mrem | millirem |
| mSv | millisievert, 10^{-3} Sievert |
| MT | metric ton |
| nCi | nanocuries, 10^{-9} curie |

| | |
|-----|-----------------------------|
| pCi | picocurie, 10^{-12} curie |
| psi | pounds per square inch |
| R | Roentgen |
| rem | Roentgen equivalent man |
| s | second |
| Sv | sievert |
| wt% | weight percent |
| yr | year |

EXECUTIVE SUMMARY

This *Draft Waste Incidental to Reprocessing Evaluation for Vitrified Low-Activity Waste Disposed Onsite at the Hanford Site, Washington* (Draft WIR Evaluation) addresses approximately 23.5 million gallons (Mgal) of separated, pretreated and vitrified low-activity waste (VLAW), from underground tanks at the Hanford Site in Washington. Specifically, this Draft WIR Evaluation assesses whether the VLAW meets the waste-incidental-to-reprocessing (WIR) criteria set forth in DOE M 435.1-1, *Radioactive Waste Management Manual*, Chapter II.B.(2)(a), and therefore is waste incidental to reprocessing of spent nuclear fuel, is not high-level radioactive waste and may be managed as low-level radioactive waste. This Draft WIR Evaluation and its references demonstrate that the criteria in DOE M 435.1-1 will be met.

The applicable DOE M 435.1-1 criteria are, in relevant part, that the wastes:

1. “Have been processed, or will be processed, to remove key radionuclides to the maximum extent that is technically and economically practical; and
2. Will be managed to meet safety requirements comparable to the performance objectives set out in 10 CFR Part 61, Subpart C, Performance Objectives; and
3. Are to be managed, pursuant to DOE’s authority under the Atomic Energy Act of 1954, as amended, and in accordance with the provisions of Chapter IV of this Manual, provided the waste will be incorporated in a solid physical form at a concentration that does not exceed the applicable concentration limits for Class C low-level waste as set out in 10 CFR 61.55, *Waste Classification*[.]”

The Hanford Site currently stores radioactive waste in underground storage tanks. The waste was generated, in part, by the prior reprocessing of spent nuclear fuel during the Manhattan Project and Cold War eras, for defense-related nuclear research, development and weapons-production activities.

Hanford’s current mission focuses on the cleanup and remediation of those wastes and ultimate closure of the Site. As part of that mission, the U.S. Department of Energy (DOE) is retrieving waste from the Hanford tanks, and has decided to separate the tank waste into a low-activity waste stream and a high-level radioactive waste stream.

For the low-activity tank waste at issue in this Draft WIR Evaluation, DOE plans to use the direct-feed low-activity waste (DFLAW) approach. The DFLAW approach is a two-phased approach that will separate and pretreat supernate (essentially the upper-most layer of tank waste that contains low concentrations of long-lived radionuclides) from some of the Hanford tanks, to generate a low-activity waste (LAW) stream.

For Phase 1, the DFLAW approach will entail the following: in-tank settling; separation (removal by decanting) of the supernate (including dissolved saltcake and interstitial liquids); filtration and then cesium removal using ion exchange columns in a tank-side cesium removal

(TSCR) unit.¹ For Phase 2, DOE plans to treat additional supernate (including dissolved saltcake and interstitial liquids) using the same processes, and will deploy either an additional TSCR unit or a filtration and cesium removal facility.

The DFLAW approach is expected to remove more than 99% of the cesium, and also remove other key radionuclides. Thus, the DFLAW approach will satisfy the first criterion in DOE M 435.1-1, Chapter II.B.(2)(a).

After pretreatment, the low-activity waste (LAW) stream will be sent by transfer lines to the Low-Activity Waste Vitrification Facility at the Hanford Site, where it will be vitrified (immobilized in borosilicate glass) beginning no later than December 31, 2023. Approximately 13,500 containers of vitrified waste will be produced using the DFLAW approach. DOE plans to dispose of the pretreated and vitrified LAW in the onsite Integrated Disposal Facility (IDF), a land disposal facility at the Hanford Site for mixed low-level radioactive waste.

Disposal of the VLAW in the IDF will meet the DOE safety requirements for low-level radioactive waste disposal and the comparable U.S. Nuclear Regulatory Commission (NRC) performance objectives at 10 CFR Part 61, Subpart C, consistent with the second criterion in DOE M 435.1-1, Chapter II.B.(2)(a). For example, the IDF performance assessment base case (which also includes other waste) within 1,000 years post-closure shows an all-pathways, annual dose to a member of the public of approximately 0.19 millirem, which is well below the 25 millirem performance objective.

In addition, the vitrified LAW will be in a solid physical form. The VLAW will not exceed the concentration limits for Class C low-level radioactive waste, as shown in this Draft WIR Evaluation. Thus, the VLAW will meet the third criterion in DOE M 435.1-1, Chapter II.B.(2)(a).

DOE is consulting with the NRC concerning this Draft WIR Evaluation. DOE is also making this Draft WIR Evaluation available for comments by States, Tribal Nations, stakeholders and the public. After consideration of NRC consultative comments and comments from States, Tribal Nations, stakeholders and the public, DOE plans to prepare a final WIR evaluation. Based on the final WIR evaluation, DOE may, in the future, determine (in a WIR Determination) whether the pretreated and vitrified LAW is waste incidental to reprocessing, is not high-level radioactive waste, and may be managed (disposed of) as low-level radioactive waste.

¹ For the applicable double-shell tanks, which are tanks that have full secondary containment, the process is as explained above. For the applicable single-shell tanks (tanks which do not have full secondary containment), the tank waste has previously settled and the supernate has been removed; dissolved saltcake (including interstitial liquids) from these single-shell tanks will be used in the DFLAW approach.

1.0 INTRODUCTION

Section Purpose

The purpose of this section is to provide introductory information that lays the foundation for detailed discussions in later sections.

Section Contents

This section describes the purpose and scope of this draft evaluation, provides background information concerning the Hanford Site, identifies the technical requirements on which this draft evaluation is based, and outlines the contents of the rest of the draft evaluation.

Key Points

- This *Draft Waste Incidental to Reprocessing Evaluation for Vitrified Low-Activity Waste Disposed Onsite at the Hanford Site, Washington* (Draft WIR Evaluation) concerns approximately 23.5 million gallons (Mgal) of separated, pretreated and vitrified low-activity waste (VLAW), from underground tanks at the Hanford Site in the State of Washington.²
- Specifically, this Draft WIR Evaluation assesses whether the VLAW is incidental to reprocessing³ of spent nuclear fuel,⁴ is not high-level radioactive waste (HLW),⁵ and may be managed as low-level radioactive waste (LLW),⁶ under the waste-incident-to-reprocessing (WIR) criteria in Chapter II.B(2)(a) of the U.S. Department of Energy (DOE) M 435.1-1, *Radioactive Waste Management Manual*. As demonstrated in this Draft WIR Evaluation and its references, the pretreated and solidified VLAW will satisfy the criteria in DOE M 435.1-1.
- The Hanford Site currently stores radioactive waste in underground storage tanks. The waste was generated, in part, by the prior reprocessing of spent nuclear fuel during the Manhattan Project and Cold War eras, for defense-related nuclear research, development and weapons-production activities.

² The volumes and quantities in this Draft WIR Evaluation are estimates under current DOE plans, and should not be viewed as limits.

³ DOE guidance describes reprocessing as “those actions necessary to separate fissile elements (U-235, Pu-239, U-233, and Pu-241) and/or transuranium elements (e.g., Np, Pu, Am, Cm, Bk) from other materials (e.g., fission products, activated metals, cladding) contained in spent nuclear fuel for the purposes of recovering desired materials.” DOE G 435.1-1, *Implementation Guide for Use with DOE M 435.1-1*, at p. II-5. That Guide goes on to explain that decladding and other head-end processes are not part of reprocessing; Id, at II-6.

⁴ The term “spent nuclear fuel” is defined in DOE M 435.1-1 in relevant part as: “Fuel that has been withdrawn from a nuclear reactor following irradiation, the constituent elements of which have not been separated by reprocessing.”

⁵ “High-level radioactive waste” is defined in Section 2(12) of the *Nuclear Waste Policy Act of 1982*, as amended (42 USC 10101 et seq.) as: “(A) the highly radioactive material resulting from the reprocessing of spent nuclear fuel, including liquid waste produced directly in reprocessing and any solid material derived from such liquid waste that contains fission products in sufficient concentrations; and (B) other highly radioactive material that the Commission, consistent with existing law, determines by rule requires permanent isolation.” Section 11.dd of the *Atomic Energy Act of 1954*, as amended (42 USC 2011, et seq.) and Section 2(10) of the *Waste Isolation Pilot Plant Land Withdrawal Act*, as amended (P.L. 102-579) incorporate the above definition.

⁶ Low-level radioactive waste is essentially defined in relevant part in Section 2(9) of the *Low-Level Radioactive Waste Policy Amendments Act of 1985*, as amended (42 USC 2021b, et seq.), as “radioactive material that ... is not high-level radioactive waste, spent nuclear fuel, or byproduct material (as defined in ... the Atomic Energy Act of 1954)[.]” Section 2(16) of the *Nuclear Waste Policy Act of 1982*, as amended (42 USC 10101, et seq.) and DOE M 435.1-1, similarly define low-level radioactive waste in relevant part as radioactive waste that “is not high-level radioactive waste, spent nuclear fuel, transuranic waste, or byproduct material[.]”

- Hanford’s current mission focuses on the cleanup and remediation of those wastes and ultimate closure of the Site. As part of this mission, DOE is retrieving waste from the Hanford tanks, and has decided to separate the tank waste into low-activity and high-level waste streams.⁷ This Draft WIR Evaluation concerns the low-activity waste stream from some of the Hanford tanks.⁸
- For the low-activity waste at issue in this Draft WIR Evaluation, DOE plans to use the direct-feed low-activity waste (DFLAW) approach.⁹ The DFLAW approach is a two-phased approach that will separate and pretreat supernate (including dissolved saltcake and interstitial liquid)¹⁰ from some of the Hanford tanks, to generate a low-activity waste stream.
- For Phase 1, the DFLAW approach will entail the following: in-tank settling; separation (removal by decanting) of the supernate (including dissolved saltcake and interstitial liquids); filtration and then cesium removal using ion exchange columns in a tank-side cesium removal unit.¹¹ For Phase 2, DOE plans to treat additional supernate (including dissolved saltcake and interstitial liquids) using the same processes, with either an additional tank-side cesium removal unit or a filtration and cesium removal facility.
- After pretreatment, the low-activity waste (LAW) will be moved by transfer lines to the Low-Activity Waste Vitrification Facility at the Hanford Site, where it will be vitrified (immobilized in borosilicate glass)¹² beginning no later than December 31, 2023.
- DOE plans to dispose of the pretreated and vitrified LAW as mixed LLW¹³ at the Hanford Integrated Disposal Facility, a land disposal facility at the Hanford Site for mixed low-level radioactive waste.
- DOE is consulting with the U.S. Nuclear Regulatory Commission concerning this Draft WIR Evaluation. DOE is also making this Draft WIR Evaluation available for comment by States, Tribal Nations, stakeholders and the public.
- After consultation with the U.S. Nuclear Regulatory Commission and consideration of comments from States, Tribal Nations, stakeholders and the public, DOE plans to prepare a final WIR Evaluation.

⁷ See 78 FR 75913, “Record of Decision: Final Tank Closure and Waste Management Environmental Impact Statement for the Hanford Site, Richland, Washington.”

⁸ DOE has not made decisions concerning the potential path forward for other low-activity tank waste at the Hanford Site. See 78 FR 75913.

⁹ See 84 FR 424, “Amended Record of Decision for the Direct-Feed Low-Activity Waste Approach at the Hanford Site, Washington.”

¹⁰ The waste in the Hanford tanks generally consists of three phases: supernate, saltcake, and sludge. Some entrained gas can also exist in the solid (saltcake and sludge) phases. The supernate is liquid remaining above the solid material that was formed by precipitation of sludge and saltcake in the tanks. The supernate represents most of the volume of the tank waste, whereas the sludge consists of a lower volume, but contains most of the long-lived radionuclides, which may persist in the environment and may be harmful to humans if ingested or inhaled. See Tank Waste Retrieval, Processing, and On-site Disposal at Three Department of Energy Sites: Final Report (National Academy of Sciences 2006).

¹¹ For the applicable double-shell tanks (DSTs), which are tanks that have full secondary containment, the process is as explained above. For the applicable single-shell tanks (SSTs, tanks which do not have full secondary containment), the tank waste has previously settled and the supernate has been removed; dissolved saltcake (including interstitial liquids) from these SSTs will be used in the DFLAW approach.

¹² Vitrification is the process of blending the waste with glass-forming materials and heating it to 2,100 °F. The mixture is poured into containers to cool and solidify. This Draft WIR Evaluation uses the term vitrified low activity waste (VLAW) which is also commonly called immobilized low activity waste (ILAW). Reference documents may use ILAW and as such is synonymous with VLAW.

¹³ Mixed waste has both a radioactive component and a hazardous waste component as defined under the *Resource Conservation and Recovery Act of 1976* (RCRA). For convenience in this Draft WIR Evaluation, the mixed LLW is hereinafter referred to simply as LLW.

- Based on the final WIR Evaluation, DOE may determine (in a future WIR Determination) whether the VLAW is incidental to reprocessing, is not HLW, and may be managed (disposed of) as LLW.

1.1 PURPOSE AND WASTE INCIDENTAL TO REPROCESSING CRITERIA

The purpose of this Draft WIR Evaluation is to assess whether the pretreated and vitrified low-activity waste (VLAW) from Hanford tanks will meet the criteria set forth in DOE M 435.1-1, *Radioactive Waste Management Manual*, Chapter II.B.(2)(a). Based on a final WIR Evaluation, DOE may determine (in a future WIR Determination) whether the VLAW is incidental to reprocessing, is not high-level radioactive waste (HLW) and may be managed (disposed of) as low-level radioactive waste (LLW).

Waste-Incidental-to-Reprocessing (WIR) Evaluation Method Criteria

DOE M 435.1-1, Chapter II.B.(2)(a), provides, in relevant part, that wastes are incidental to reprocessing, are not HLW, and may be managed as LLW if an evaluation shows that the wastes:

1. Have been processed, or will be processed, to remove key radionuclides to the maximum extent that is technically and economically practical; and
2. Will be managed to meet safety requirements comparable to the performance objectives set out in 10 CFR Part 61, Subpart C, Performance Objectives; and
3. Are to be managed, pursuant to DOE's authority under the Atomic Energy Act of 1954, as amended, and in accordance with the provisions of Chapter IV of this Manual, provided the waste will be incorporated in a solid physical form at a concentration that does not exceed the applicable concentration limits for Class C low-level waste as set out in 10 CFR 61.55, Waste Classification.¹⁴

Although the WIR criteria in DOE M 435.1-1 are generally similar to the provisions in Section 3116(a) of the *Ronald W. Reagan National Defense Authorization Act for Fiscal Year 2005* (Public Law 108-375), that Act only applies to waste remaining in South Carolina and Idaho. Nevertheless, as a matter of policy, DOE has considered the Section 3116(a)(1) criteria for perspective and general consistency. This matter is addressed in detail in Appendix C.

1.2 SCOPE

This Draft WIR Evaluation addresses only the Hanford VLAW described in this Draft WIR Evaluation. This Draft WIR Evaluation does not address other wastes, equipment, facilities, systems, or supplemental LAW treatment. This Draft WIR Evaluation is premised on the facts,

¹⁴ This provision in DOE M 435.1 also includes the following language: "or will meet alternative requirements for waste classification and characterization as DOE may authorize." DOE is not using or relying upon this language in this Draft WIR Evaluation.

assumptions and analyses contained or referenced herein. Accordingly, a potential WIR Determination, made in reliance on the final WIR Evaluation, can only cover situations consistent with the facts, assumptions and analysis therein.

1.3 BACKGROUND AND OVERVIEW OF DIRECT-FEED LOW-ACTIVITY WASTE APPROACH

This background discussion is based primarily on DOE/EIS-0391, *Final Tank Closure and Waste Management Environmental Impact Statement for the Hanford Site, Richland, Washington* (TC&WM EIS) and PNNL-13605, *A Short History of Hanford Waste Generation, Storage, and Release*, unless otherwise noted.

The Hanford Site is located in southeastern Washington State along the Columbia River. Figure 1-1 shows the layout of the Site.

Figure 1-1. Hanford Site Map.

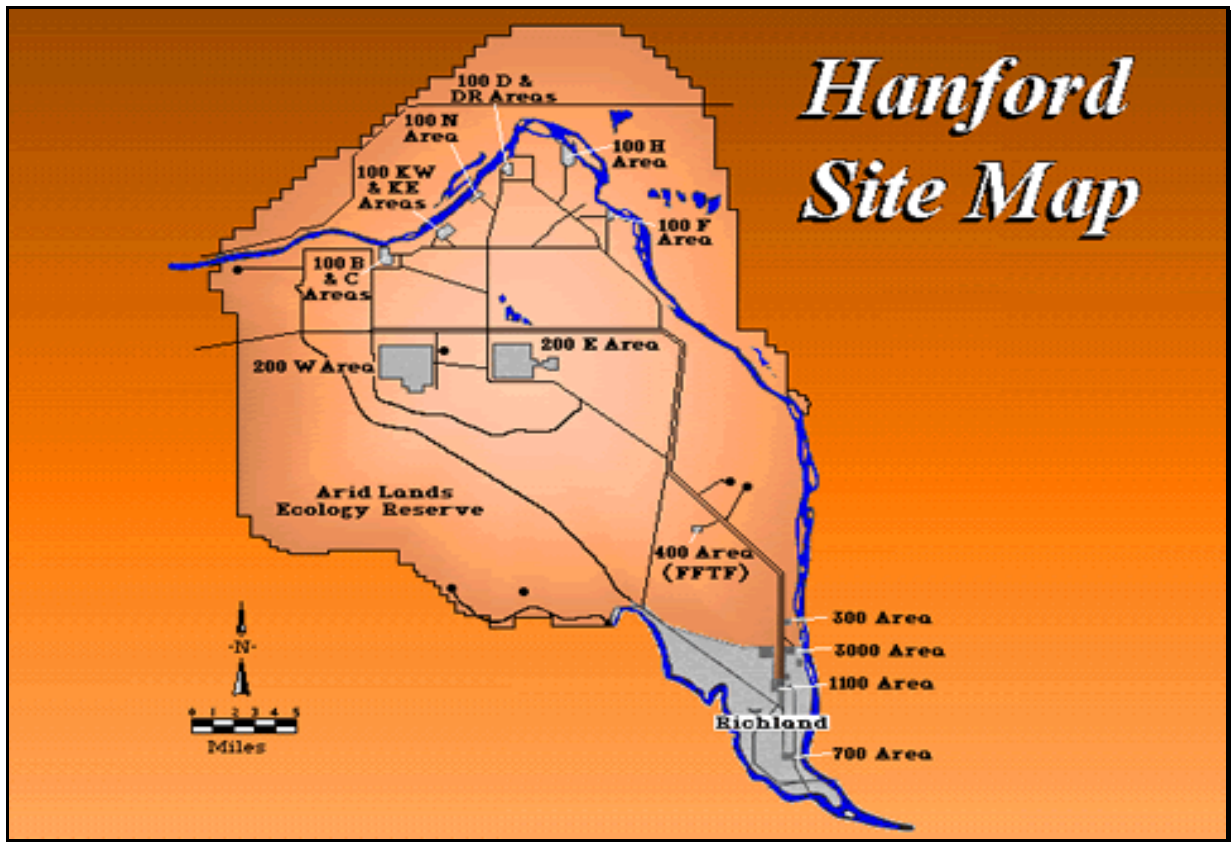

FFTF = Fast Flux Test Facility

During World War II, the U.S. Government established the Hanford Site as part of the Manhattan Project. The Site's mission focused primarily on production of plutonium for defense purposes and defense-related research and development during the Manhattan Project and Cold War eras. The plutonium production complex eventually included nine nuclear reactors and

five processing plants. The last reactor was shut down in 1987, and the last reprocessing plant closed in 1990.

The reprocessing plants separated the plutonium in spent nuclear fuel (SNF) and irradiated targets¹⁵ from unwanted radionuclides and chemicals,¹⁶ using various chemical precipitation and solvent extraction techniques. Five processing plants were built in the 200 Area. Starting in late 1944 and 1945, T and B Plants used a bismuth phosphate batch processing technology (BPP) to recover plutonium from uranium metal fuel. This batch processing technology relied on multiple, highly-selective chemical precipitation processes to separate and purify plutonium.

As the higher-efficiency solvent extraction technologies REDOX (Reduction and Oxidation) and then PUREX (Plutonium and Uranium Extraction) became available in the 1950s, the BPP recovery operations were terminated. The fifth processing plant (U Plant) did not reprocess SNF, but was used to recover uranium that the BPP discharged as tank waste.

Fuel reprocessing from 1944 to 1989 at the Hanford Site resulted in radioactive waste. Approximately 525 Mgal of the waste was reduced by evaporation to approximately 54.1 Mgal¹⁷ which was stored in 177 underground storage tanks. Of the 177 tanks, 149 are carbon steel single-shell tanks (SSTs)¹⁸ that were built between 1943 and 1964. The remaining 28 are carbon steel double-shell tanks (DSTs) and were built between 1968 and 1986.

The present Hanford Site mission focuses on cleanup and remediation. Today, nearly all liquid waste resides in the higher-integrity DSTs. Progress is being made in retrieving waste from the SSTs and transferring their waste to DSTs.

DOE previously decided to separate the tank wastes into LAW and HLW streams, and to vitrify some of the LAW and all of the HLW in the Hanford Tank Waste Treatment and Immobilization Plant (WTP).¹⁹ Thereafter, DOE decided to use the direct-feed low-activity waste (DFLAW) approach for some of the LAW stream (84 FR 424, “Amended Record of Decision for the Direct-Feed Low-Activity Waste Approach at the Hanford Site, Washington”).

¹⁵ Such targets were irradiated to produce isotopes for medical and other purposes.

¹⁶ It was recognized early on that Hanford’s liquid waste from reprocessing had lower heat and radioactivity (e.g., fission product content) than wastes from commercial reprocessing. The Atomic Energy Commission noted in 1970 that the tank wastes at Hanford and Savannah River “...differ materially in radioactivity level, heat output and chemical composition from wastes produced by licensed fuel reprocessing plants planned or under construction. For example, the Savannah River and Hanford wastes have been chemically neutralized, contain large volumes of non-fission product materials, and have heat and radioactivity outputs many times lower than the licensed plant wastes” (35 FR 17530, “Licensing of Production and Utilization Facilities”).

¹⁷ The total tank waste volume will increase and decrease over time as waste is retrieved and/or water is evaporated or added during operations, e.g., sluicing to retrieve tank waste.

¹⁸ Single-shell tanks do not have secondary containment. Double-shell tanks have full secondary containment (essentially a tank within a tank).

¹⁹ DOE/EIS-0391, *Final Tank Closure and Waste Management Environmental Impact Statement for the Hanford Site, Richland, Washington* (TC&WM EIS) evaluated alternative approaches to treatment and management of the Hanford wastes, including those currently stored in the tanks. 78 FR 75913, “Record of Decision: Final Tank Closure and Waste Management Environmental Impact Statement for the Hanford Site, Richland, Washington” selected DOE’s Alternative 2B, without technetium removal and with no decision regarding supplemental LAW treatment. This alternative involves separation of tank wastes into low-activity and high-level waste streams.

Under the DFLAW approach, DOE plans to use a sequenced, two-phase approach that will separate and pretreat supernate from some of the Hanford tanks into a LAW stream. Phase 1 of the DFLAW approach entails the following: in-tank settling; separation (removal by decanting) of the supernate (including dissolved saltcake and interstitial liquids); filtration and then cesium removal, using ion exchange (IX) columns in a tank-side cesium removal (TSCR) unit. For Phase 2, DOE plans to treat additional supernate (including dissolved saltcake and interstitial liquids) using the same processes, with either an additional TSCR unit or a filtration and cesium removal facility. DOE plans to vitrify the LAW treated by the DFLAW approach at the LAW Vitrification Facility at the WTP.

The containers of vitrified LAW will be disposed of at the Hanford Site Integrated Disposal Facility (IDF) in the 200 East Area of the Hanford Site. The IDF is a land disposal facility for mixed LLW. The IDF is authorized by DOE pursuant to its authority under the *Atomic Energy Act of 1954* (AEA) as amended²⁰ and permitted by the State of Washington Department of Ecology (Ecology) pursuant to the *Resource Conservation and Recovery Act of 1976* (RCRA)²¹ and the Washington State *Hazardous Waste Management Act of 1976* as amended (*Revised Code of Washington* 70.105, “Hazardous Waste Management”) for dangerous waste.

The *Hanford Federal Facility Agreement and Consent Order* (HFFACO) (Ecology et al. 1989) that was signed by DOE, Ecology, and the U.S. Environmental Protection Agency (EPA) on May 15, 1989, is an enforceable agreement that requires DOE to clean up and dispose of radioactive and hazardous waste at the Hanford Site and close facilities that have been used to treat, store, or dispose of such waste. A Consent Decree, amended in 2016, requires the WTP LAW Vitrification Facility hot commissioning to be complete by December 31, 2023 (Amended Consent Decree in Case No. 2:08-CV-05085-RMP [March 11, 2016]). “LAW Vitrification Facility Hot Commissioning Complete” means the point at which the LAW Vitrification Facility has demonstrated its ability to produce vitrified LAW (glass) of acceptable quality. See *id.*

1.4 CONSULTATION AND OPPORTUNITY FOR PUBLIC REVIEW

DOE is consulting with the U.S. Nuclear Regulatory Commission (NRC) concerning this Draft WIR Evaluation.²² In addition, DOE is making this Draft WIR Evaluation available for comments by States, Tribal Nations, stakeholders and the public.

DOE plans to issue a final WIR Evaluation following consultation with the NRC and after consideration of comments from the States, Tribal Nations, stakeholders and the public. Based on the final WIR Evaluation, DOE may determine (in a future WIR Determination) whether the

²⁰ *Atomic Energy Act of 1954*, as amended, 42 USC 2901 *et seq.*

²¹ *Resource Conservation and Recovery Act of 1976*, 42 USC 6901 *et seq.*

²² DOE previously consulted with the NRC under analogous criteria, set forth in a March 2, 1993 letter from R. Bernero, NRC to J. Lytle, DOE (Bernero 1993), that were the precursor to the WIR criteria in Chapter II.B.(2)(a) of DOE M 435.1-1. In 1997, NRC preliminarily found that it was in provisional agreement with DOE that the LAW was incidental to reprocessing and not HLW subject to NRC licensing jurisdiction, but that preliminary information available at the time was not sufficient to make an absolute determination (“Classification of Hanford Low-Activity Waste Fraction” [NRC 1997]). This interaction is discussed further in Appendix D.

VLAW meets the criteria in DOE M 435.1-1, is not HLW, and is to be managed (and disposed of) as LLW.

1.5 ORGANIZATION OF THIS DRAFT WIR EVALUATION

Information in the remainder of this Draft WIR Evaluation is presented as follows.

Section 2 describes the background of the Hanford Site, Hanford Site characteristics, the DFLAW approach, the LAW Vitrification Facility at the Hanford WTP, and the characteristics of the VLAW.

Section 3 describes DOE M 435.1-1 criteria.

Section 4 describes how key radionuclides will be removed from the waste to the maximum extent technically and economically practical.

Section 5 describes how the waste will be managed to meet safety requirements comparable to NRC performance objectives in Title 10, *Code of Federal Regulations* (CFR), Part 61, “Licensing Requirements for Land Disposal of Radioactive Waste”, Subpart C – Performance Objectives.

Section 6 explains that the VLAW will be in a solid physical form and that radionuclide concentrations in the VLAW will not exceed the Class C concentration limits.

Section 7 presents preliminary conclusions for this Draft WIR Evaluation.

Section 8 identifies the references cited in this Draft WIR Evaluation.

Appendix A compares DOE and NRC LLW disposal performance objectives and performance measures.

Appendix B compares applicable DOE dose standards and the similar NRC dose standards during operations and discusses their comparability.

Appendix C discusses the criteria in Section 3116 of the *Ronald W. Reagan National Defense Authorization Act for Fiscal Year 2005*.

Appendix D provides a discussion of events leading to the 1997 NRC interaction and includes the letter from the NRC, in which NRC provisionally agreed that the LAW was incidental to reprocessing.

Appendix E provides the steps to prepare tank 241-AP-106 (AP-106) as the Interim Storage LAW Tank.

Appendix F provides the comparison of the Low Activity Waste Pretreatment System (LAWPS) prior approach and the DFLAW approach to filtration.

2.0 BACKGROUND

Section Purpose

The purpose of this section is to provide background information to support the discussions in the sections that follow. This section describes the Hanford Site and its history, discusses the River Protection Project, describes the WTP, describes the DFLAW approach, describes the characteristics of the VLAW, and describes the IDF at Hanford.

Key Points

- The River Protection Project mission is to retrieve and treat Hanford's tank waste and close the tank farms.
- The 54.1 Mgal of wastes in the underground waste storage tanks contain 139 MCi of radioactivity decayed to July 1, 2017, with over 97% of this amount from ^{137}Cs and ^{90}Sr and their equilibrium daughter products ($^{137\text{m}}\text{Ba}$ and ^{90}Y) (inventories from Best-Basis Inventory database).
- Under current DOE plans, the DFLAW approach will pretreat tank waste (supernate, including dissolved saltcake and interstitial liquids) from some of the Hanford tanks into LAW, which will be transferred to the LAW Vitrification Facility at the WTP.
- The LAW Vitrification Facility at WTP will use two large melters to vitrify approximately 23.5 Mgal of LAW in borosilicate glass and pour the vitrified LAW into containers, where the VLAW will cool and harden.
- In the DFLAW approach, approximately 13,500 containers of VLAW (glass) will be produced.
- The containers of VLAW will be disposed of at the Hanford Site IDF, located in the 200 East Area at the Hanford Site.

2.1 HANFORD HISTORY

This brief history was compiled primarily from the TC&WM EIS (DOE/EIS-0391) and PNNL-13605.

The Hanford Site is located in southeastern Washington State along the Columbia River (<https://www.hanford.gov/page.cfm/HanfordHistory>). Hanford's mission included defense-related nuclear research, development, and nuclear weapons production activities from the early 1940s to 1989. Afterwards, Hanford's mission has been to provide environmental remediation of the radioactive and hazardous wastes from prior plutonium production.

In 1943, the War Department began the process of recruiting workers to build nuclear reactors and the reprocessing facilities required to extract plutonium for nuclear weapons. The first nuclear reactor (B Reactor) and the first processing plant (T Plant) were completed and operating

in late 1944. Between 1943 and 1963, nine reactors were built in the 100 Area along the shore of the Columbia River. The reactors differed in size and power level.

The four reprocessing plants in the 200 Area processed the irradiated slugs from the reactors to recover the plutonium produced during reactor operation. The irradiated slugs were cooled in water pools and then treated through chemical separation in the reprocessing plants. The irradiated slugs were dissolved and the plutonium was separated from the remaining uranium, fission products, and transuranic elements.

From the mid-1960s through 1971, the older reactors were shut down leaving only N Reactor operating on the Site. This dual-purpose reactor continued its mission of producing plutonium and electricity until 1987.

Hanford reprocessed irradiated uranium and generated several hundred thousand metric tons of chemical and radioactive waste during its production period. This waste included HLW, transuranic waste, LLW, mixed low-level radioactive waste (MLLW – waste that contains both a radioactive component and a hazardous waste component), and nonradioactive hazardous waste, as defined under RCRA. Hanford tank waste is considered to be mixed waste that is regulated under both RCRA and the AEA.

2.2 HANFORD SITE AND INTEGRATED DISPOSAL FACILITY CHARACTERISTICS

Hanford Site characteristics are excerpted from the IDF performance assessment (PA), RPP-RPT-59958, *Performance Assessment for the Integrated Disposal Facility, Hanford Site, Washington*. See the IDF PA for additional information and complete references.

2.2.1 Hanford Site

2.2.1.1 Location of Hanford Site

The Hanford Site encompasses ~1,517 km² (~586 mi²) in Benton, Franklin, and Grant Counties, located in south-central Washington State (Figure 2-1) within the semi-arid Pasco Basin of the Columbia Plateau. Nearby towns are Richland (40 km [25 mi] to the southeast) and Yakima (80 km [50 mi] to the west), with the nearby major metropolitan areas being Spokane (201 km [125 mi] to the northeast), Seattle (241 km [150 mi] to the northwest) and Portland, Oregon (~400 km [~250 mi] downstream on the Columbia River). The Hanford Site stretches ~48 km (~30 mi) north to south and ~38 km (~24 mi) east to west, immediately north-northwest of the confluence of the Yakima and Columbia Rivers, the Cities of Kennewick, Pasco, and Richland (the Tri-Cities), and the City of West Richland.

Figure 2-1. U.S. Department of Energy's Hanford Site and Surrounding Area.

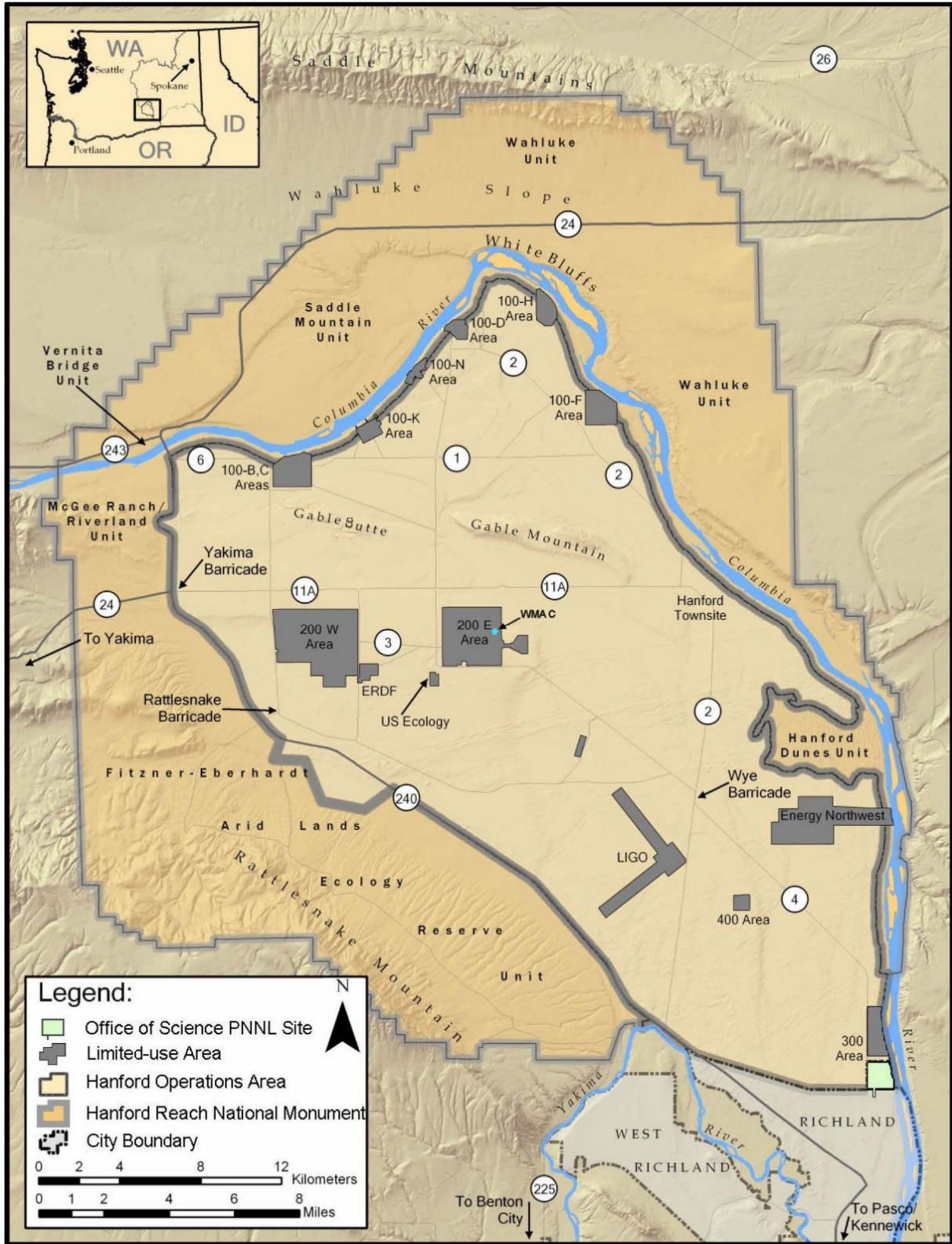

ERDF = Environmental Restoration Disposal Facility
 LIGO = Laser Interferometer Gravitational Wave Observatory

PNNL = Pacific Northwest National Laboratory
 WMA = Waste Management Area

The Columbia River flows eastward through the northern part of the Hanford Site and then turns south, forming part of the eastern Site boundary. This section of the river is known as the Hanford Reach and is a free-flowing section of the Columbia River, ~82 km (~51 mi) long. It is named after a large northward bend in the river's otherwise southbound course. It is the only section of the Columbia River in the U.S. that is neither tidal nor part of a reservoir. The following seven dams are upstream of the Hanford Site and are listed from closest to furthest from Hanford: Priest Rapids, Wanapum, Rocky Island, Rocky Reach, Wells, Chief Joseph, and Grand Coulee. Other important rivers near the Hanford Site are the Yakima River to the south and southwest and the Snake River to the east. The Cascade Mountains, which are ~160 km (100 mi) to the west, have an important effect on the climate of the area.

The Yakima River runs near the southern boundary of the Hanford Site, joining the Columbia River at the City of Richland. Rattlesnake Mountain, Yakima Ridge, and Umtanum Ridge form the southwestern and western boundaries of the Site, and Saddle Mountain forms its northern boundary. The plateau of the central portion of the Hanford Site is punctuated by two small east-west ridges, Gable Butte and Gable Mountain. Lands adjoining the Hanford Site to the west, north, and east are principally range and agricultural areas.

The location of the tank farms in the 200 East and 200 West Areas on the Central Plateau of the Hanford Site are illustrated in Figure 2-1. The IDF is located in the southern portion of the 200 East Area of the Central Plateau of the Hanford Site (Figure 2-2). The initial phase of the facility was constructed in 2005. Future expansion plans for the cells in the current configuration extend the facility towards the south.

2.2.1.2 Hanford Site Description

The Hanford Site is a relatively undeveloped area of shrub-steppe (a drought-resistant, shrub and grassland ecosystem) that contains a rich diversity of plant and animal species. This area has been protected from disturbance, except for fire, over the past 60 years. This protection has allowed plant species and communities that have been displaced by agriculture and development in other parts of the Columbia Basin to thrive at the Hanford Site.

In the past, the Hanford Site was a U.S. Government defense materials production site that included nuclear reactor operation, uranium and plutonium processing, storage and processing of SNF, and management of radioactive and hazardous chemical wastes. The current mission at Hanford includes managing waste products, cleaning up the Site, researching new ideas and technologies for waste disposal and cleanup, and reducing the size of the Site. Present Hanford programs are diversified and include the management of radioactive waste, cleanup of waste sites and soil and groundwater contaminated by past waste releases, stabilization and storage of SNF, research into renewable energy and waste disposal technologies, and cleanup of contamination.

Figure 2-2. Key Facilities in the 200 East and 200 West Areas of the Hanford Site.

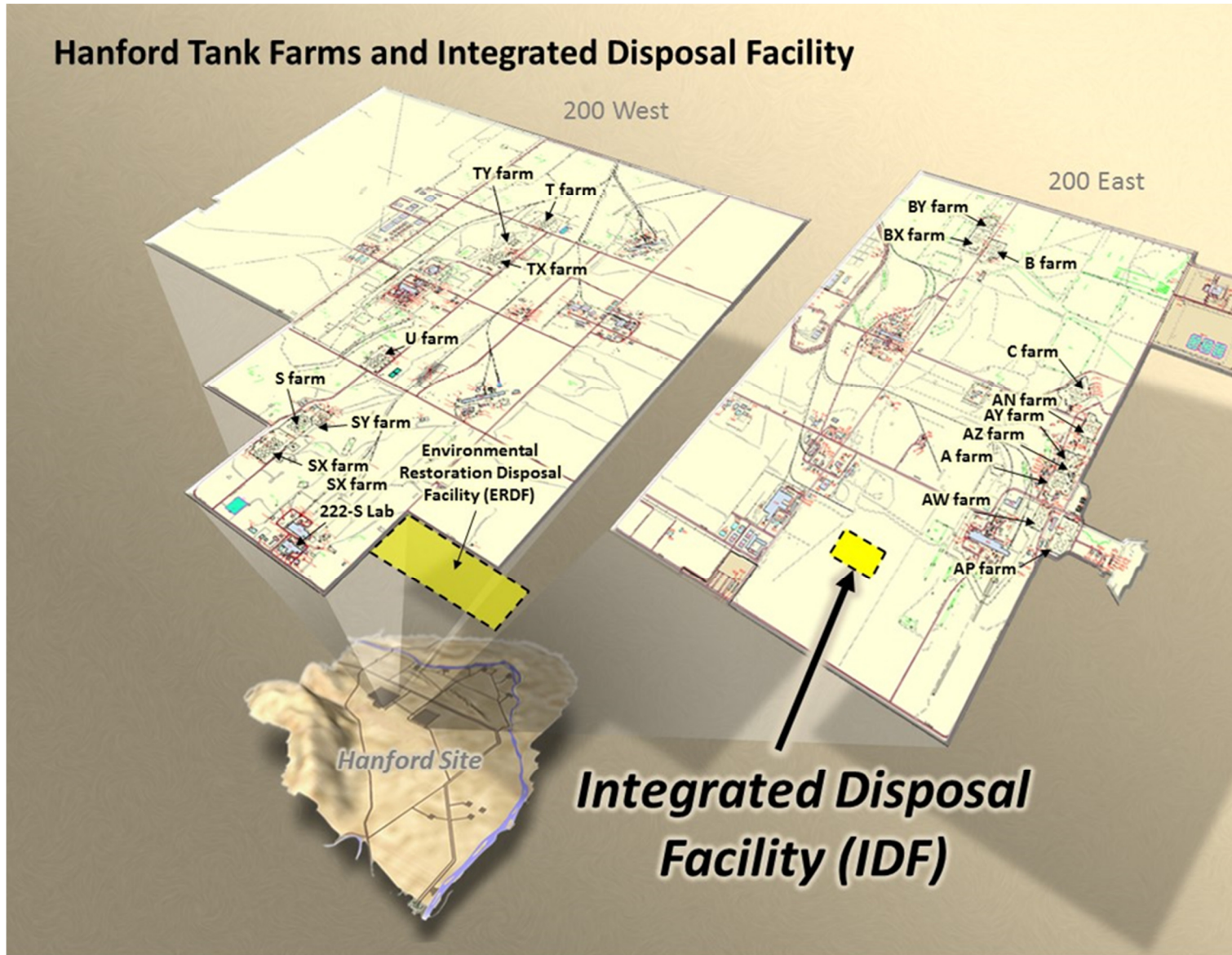

The Hanford Site is owned and used primarily by DOE, but portions of it are owned, leased, or administered by other U.S. Government agencies. Public access to the Site is limited to travel on the Route 4 and Route 10 access roads as far as the Wye Barricade, State Routes 24 and 240, and the Columbia River. By restriction of access, the public is shielded from portions of the Site formerly used for the production of nuclear materials and currently used for waste storage and disposal. Only ~6% of the land area has been disturbed and is actively used, leaving mostly vacant land with widely scattered facilities. Figure 2-3 shows the generalized land use at Hanford.

In June 2000, a Presidential proclamation established the 78,914-hectare (195,000-acre) Hanford Reach National Monument to protect the nation's only un-impounded stretch of the Columbia River above Bonneville Dam and the largest remnant of the shrub-steppe ecosystem that once blanketed the Columbia River Basin. In 2003, DOE and the U.S. Fish and Wildlife Service began management of the monument. The U.S. Fish and Wildlife Service administered three major management units of the monument totaling ~668 km² (~258 mi²). These included (1) the Fitzner/Eberhardt Arid Lands Ecology Reserve Unit, a 310-km² (120-mi²) tract of land in the southwestern portion of the Hanford Site; (2) the Saddle Mountain Unit, a 129-km² (50-mi²) tract of land located north-northwest of the Columbia River and generally south and east of State Highway 24; and (3) the Wahluke Unit, a 225-km² (87-mi²) tract of land located north and east of both the Columbia River and the Saddle Mountain Unit.

DOE anticipates that the Hanford Site will remain in Federal ownership for the foreseeable future (DOE/RL-2001-41, *Sitewide Institutional Controls Plan for Hanford CERCLA Response Actions and RCRA Corrective Actions*). In the event that any of the Hanford Site land areas are transferred to an outside entity, the Institutional Controls that will remain in place on transfer of the land will be conveyed using the appropriate mechanism at the time of the transfer.

2.2.2 Meteorology and Climatology

The climate of the Pasco Basin, where the Hanford Site is located, can be classified as either mid-latitude semiarid or mid-latitude desert, depending on which climatological classification system is being used. Large diurnal temperature variations are common, resulting from intense solar heating and night-time cooling. Summers are warm and dry with abundant sunshine. Daytime high temperatures in June, July, and August can exceed 40 °C (104 °F). Winters are cool with occasional precipitation that makes up ~44% of the yearly total. During the winter, outbreaks of cold air associated with modified arctic air masses can reach the area and cause temperatures to drop below -18 °C (0.4 °F). Overcast skies and fog occur during the fall and winter months.

The region's climate is greatly influenced by the Pacific Ocean and the Cascade Mountain Range to the west, and other mountain ranges to the north and east. The Pacific Ocean moderates temperatures throughout the Pacific Northwest, and the Cascade Range generates a rain shadow that limits rain and snowfall in the eastern half of Washington State. The Cascade Range also serves as a source of cold air drainage, which has a considerable effect on the wind regime on the Hanford Site. Mountain ranges to the north and east of the region shield the area from the severe winter storms and frigid air masses that move southward across Canada.

Figure 2-3. Generalized Land Use of the Hanford Site and Adjacent Areas.

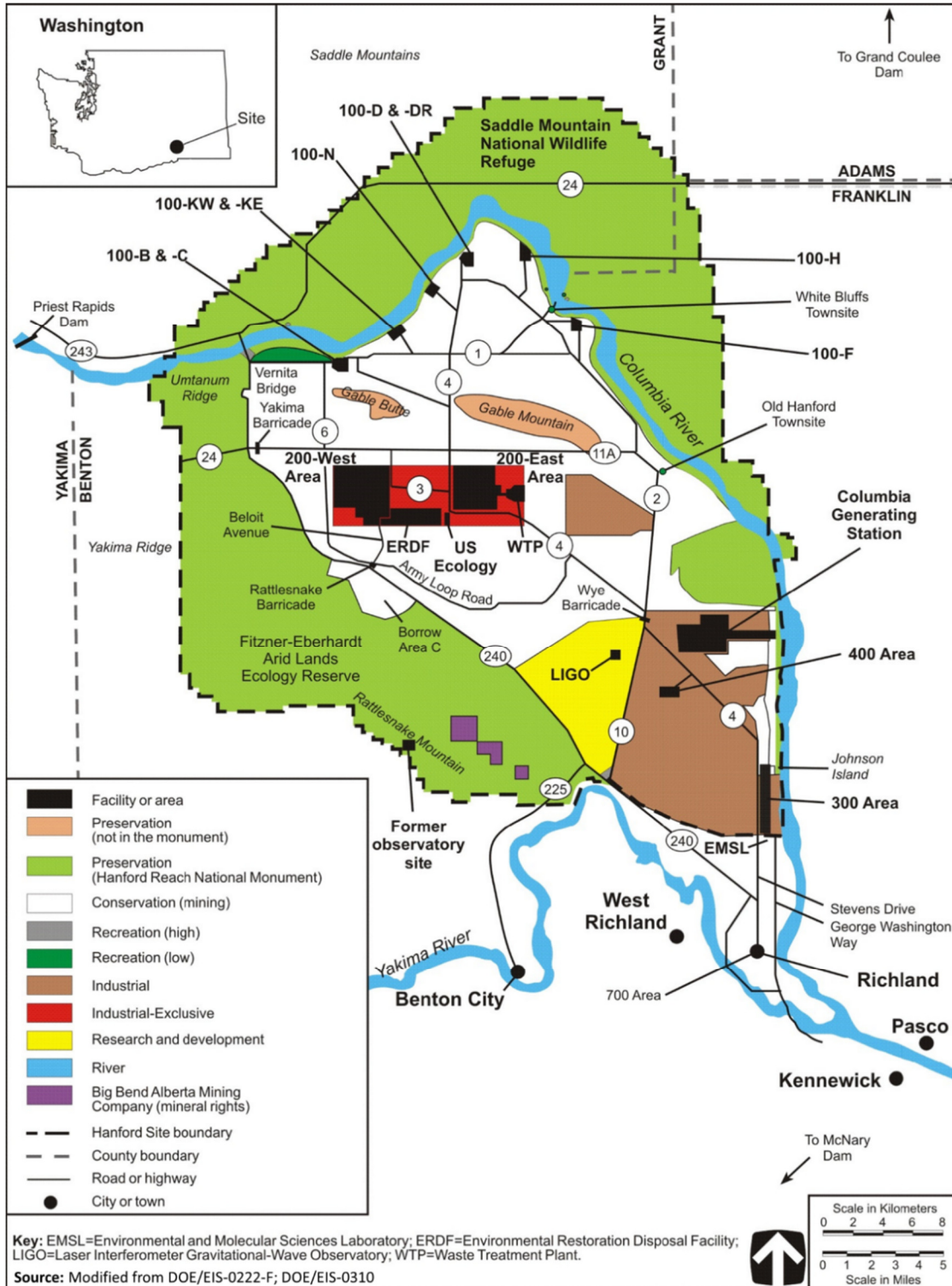

References:
 DOE/EIS-0222-F, *Final Hanford Comprehensive Land-Use Plan Environmental Impact Statement*.
 DOE/EIS-0310, *Final Programmatic Environmental Impact Statement for Accomplishing Expanded Civilian Nuclear Energy Research and Development and Isotope Production Missions in the United States, Including the Role of the Fast Flux Test Facility*.

2.2.2.1 Current Climatological Data

Climatological data for the Hanford Site are compiled at the Hanford Meteorological Station (HMS), which is located on the Central Plateau, just outside the northeast corner of the 200 West Area and ~4 km (~2.5 mi) west of the 200 East Area. To characterize meteorological differences accurately across the Hanford Site, the HMS operates a network that currently contains 30 monitoring stations (Figure 2-4). Data are collected and processed at each station, and information is transmitted to the HMS every 15 minutes. This monitoring network has been in full operation since the early 1980s. Data from the HMS capture the general climatic conditions for the region and describe the specific climate of the Central Plateau. Meteorological measurements have been made at the HMS since late 1944. Before the HMS was established, local meteorological observations were made at the old Hanford town site (1912 through late 1943) and in Richland (1943 to 1944). Meteorological data collected at the HMS are representative of conditions at the IDF.

2.2.2.2 Temperature and Humidity

From 1945 through 2010, the record maximum temperature was 45 °C (113.0 °F) recorded in August 1961, July 2002, and July 2006. The record minimum temperature was -30.6 °C (-23.1 °F) in February 1950. Normal monthly average temperatures ranged from a low of -0.2 °C (31.6 °F) in December to a high of 24.6 °C (76.3 °F) in July. During winter, the highest monthly average temperature at the HMS was 6.9 °C (44.4 °F) in February 1991, and the record lowest was -11.1 °C (12.0 °F) in January 1950. During summer, the record maximum monthly average temperature was 27.9 °C (82.2 °F) in July 1985, and the record minimum was 17.2 °C (63.0 °F) in June 1953. Table 2-1 provides the average monthly temperatures for the last 13 years along with average annual temperature. The bottom two rows provide the average annual temperature from 1947 to 2013, and the normal temperature which is a 30-year average from 1980 to 2010. The normal annual relative humidity at the HMS is 54%. Humidity is highest during winter, averaging ~76%, and lowest during summer, averaging ~36%.

2.2.2.3 Precipitation

Average annual precipitation at the HMS is 17 cm (6.7 in.). During 1995, the wettest year on record, 31.3 cm (12.3 in.) of precipitation was measured; during 1976, the driest year, only 7.6 cm (3 in.) was measured. The wettest season on record was the winter of 1996-1997 with 14.1 cm (5.6 in.) of precipitation; the driest season was the summer of 1973, when only 0.1 cm (0.04 in.) of precipitation was measured. Most precipitation occurs during the late autumn and winter, with more than half of the annual amount occurring from November through February. Days with greater than 1.3 cm (0.51 in.) precipitation occur on average less than one time each year. Table 2-2 provides the monthly and average annual precipitation at HMS since 2000. The bottom two lines provide the average yearly precipitation since 1947 and normal precipitation, which is a 30-year average from 1980 to 2010.

Average snowfall ranges from 0.25 cm (0.1 in.) during October to a maximum of 13.2 cm (5.2 in.) during December and decreases to 1.3 cm (0.5 in.) during March. The record monthly snowfall of 59.4 cm (23.4 in.) occurred during January 1950. The seasonal record snowfall of 142.5 cm (56.1 in.) occurred during the winter of 1992-1993. Snowfall accounts for ~38% of all precipitation from December through February.

Figure 2-4. Hanford Meteorological Monitoring Network Wind Roses in 2010 at the 9.1-meter (30-foot) Level.

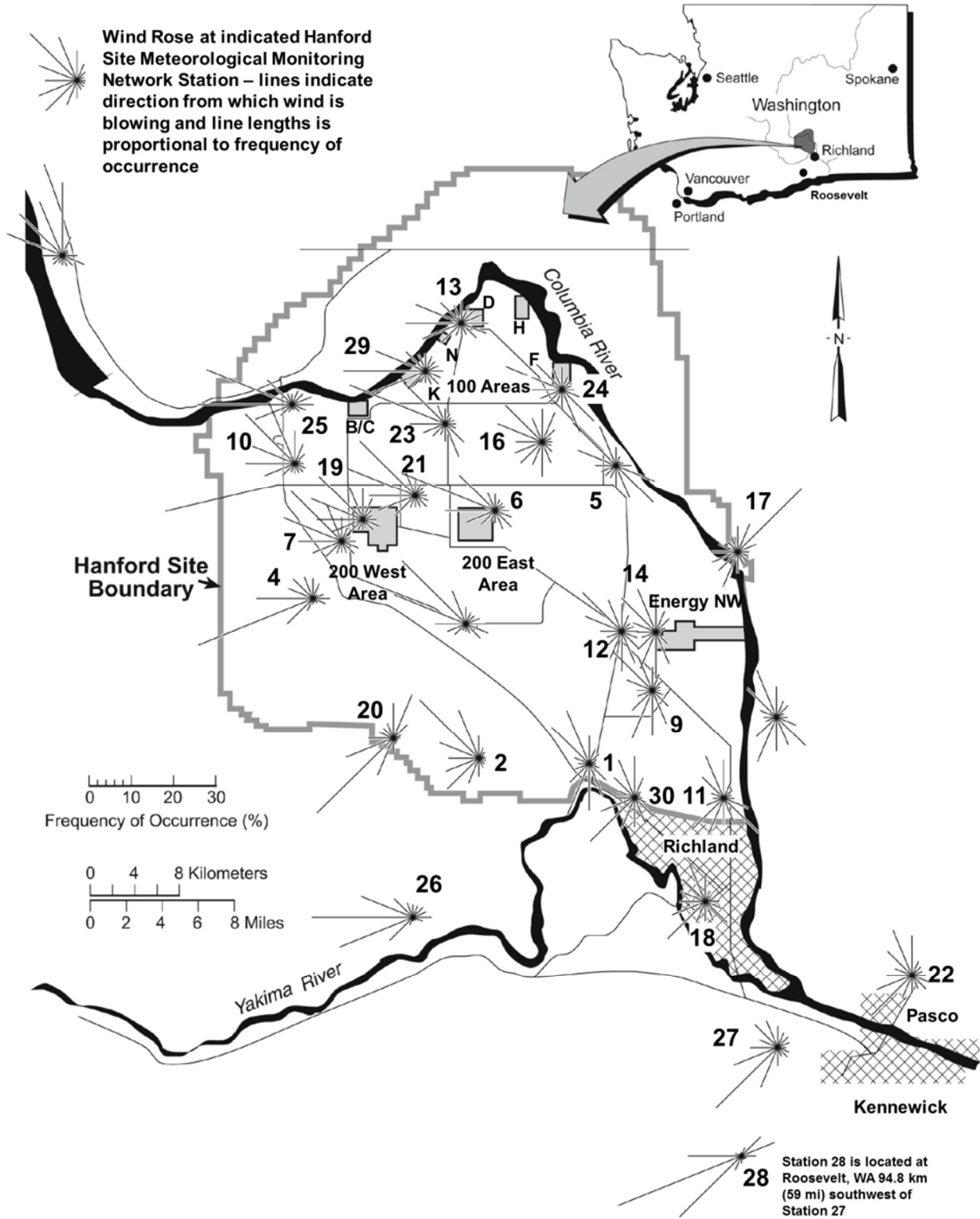

Table 2-1. Monthly and Average Annual Temperatures at Hanford Meteorological Station since 2000 (°C).

| YEAR | JAN | FEB | MAR | APR | MAY | JUN | JUL | AUG | SEP | OCT | NOV | DEC | ANNUAL |
|-------------|------------|------------|------------|------------|------------|------------|------------|------------|------------|------------|------------|------------|---------------|
| 2000 | 0.5 | 3.7 | 7.1 | 13.0 | 16.2 | 21.1 | 24.2 | 23.3 | 17.6 | 11.2 | 1.1 | -1.2 | 11.4 |
| 2001 | 0.8 | 2.1 | 8.2 | 10.8 | 17.6 | 19.2 | 24.4 | 25.4 | 20.6 | 11.9 | 6.0 | 1.6 | 12.4 |
| 2002 | 3.1 | 3.6 | 5.8 | 11.8 | 15.6 | 22.0 | 26.4 | 24.2 | 19.1 | 10.2 | 5.0 | 2.9 | 12.4 |
| 2003 | 3.3 | 4.4 | 9.4 | 11.2 | 16.2 | 22.5 | 26.8 | 24.7 | 20.7 | 14.1 | 3.2 | 0.5 | 13.1 |
| 2004 | -1.6 | 2.8 | 9.8 | 12.7 | 16.4 | 21.3 | 26.4 | 25.5 | 18.3 | 12.5 | 4.3 | 2.2 | 12.6 |
| 2005 | -1.1 | 3.2 | 9.4 | 12.0 | 17.9 | 20.3 | 25.3 | 24.8 | 18.4 | 12.4 | 3.5 | -2.6 | 11.9 |
| 2006 | 3.6 | 2.3 | 7.2 | 11.2 | 17.0 | 21.3 | 26.7 | 23.8 | 19.3 | 11.3 | 4.4 | -1.7 | 12.2 |
| 2007 | -1.8 | 3.2 | 8.6 | 11.3 | 17.3 | 20.3 | 27.2 | 23.3 | 18.7 | 10.8 | 4.0 | 0.4 | 11.9 |
| 2008 | -2.7 | 4.8 | 6.3 | 9.3 | 17.6 | 20.1 | 25.1 | 23.7 | 18.9 | 11.3 | 5.7 | -3.9 | 11.3 |
| 2009 | -0.7 | 1.7 | 5.5 | 10.9 | 16.8 | 21.9 | 26.5 | 24.6 | 20.2 | 10.1 | 5.0 | -4.1 | 11.6 |
| 2010 | 3.3 | 5.6 | 8.3 | 11.8 | 14.4 | 19.4 | 24.8 | 23.7 | 18.8 | 12.3 | 2.6 | 0.9 | 12.2 |
| 2011 | 0.9 | 1.7 | 6.7 | 9.1 | 14.0 | 19.4 | 23.0 | 24.7 | 20.8 | 12.3 | 3.6 | -0.7 | 11.3 |
| 2012 | 0.2 | 3.2 | 7.6 | 12.7 | 16.2 | 18.9 | 25.6 | 25.4 | 19.7 | 11.6 | 5.6 | 2.4 | 12.4 |
| 2013 | -1.2 | 3.9 | 7.9 | 12.0 | 17.3 | 21.0 | 27.1 | 25.4 | 20.7 | 11.4 | 3.6 | -2.8 | 12.2 |
| AVERAGE | -0.4 | 3.2 | 7.4 | 11.6 | 16.6 | 20.7 | 24.9 | 24.0 | 19.1 | 11.7 | 4.5 | 0.1 | 11.9 |
| NORMAL* | 0.8 | 3.4 | 8.1 | 11.9 | 16.7 | 20.9 | 25.1 | 24.3 | 19.1 | 11.7 | 4.7 | -0.5 | 12.2 |

* Normal is a 30-year average from 1980 to 2010.

Table 2-2. Monthly and Average Annual Precipitation at Hanford Meteorological Station since 2000 (cm).

| YEAR | JAN | FEB | MAR | APR | MAY | JUN | JUL | AUG | SEP | OCT | NOV | DEC | ANNUAL |
|----------------|------------|------------|------------|------------|------------|------------|------------|------------|------------|------------|------------|------------|---------------|
| 2000 | 2.77 | 2.84 | 2.39 | 1.45 | 1.96 | 0.64 | 1.17 | Trace | 1.42 | 1.45 | 2.74 | 1.70 | 20.52 |
| 2001 | 0.74 | 1.07 | 1.70 | 2.11 | 0.20 | 3.23 | 0.13 | 0.20 | 0.33 | 0.94 | 4.24 | 2.03 | 16.92 |
| 2002 | 1.07 | 1.70 | 0.48 | 0.74 | 0.41 | 1.65 | 0.41 | 0.03 | Trace | 0.30 | 0.97 | 5.99 | 13.74 |
| 2003 | 4.75 | 2.08 | 0.66 | 5.66 | 0.20 | Trace | 0.00 | 1.17 | 0.61 | 0.18 | 0.38 | 4.98 | 20.68 |
| 2004 | 5.38 | 2.34 | 0.91 | 0.53 | 2.26 | 2.08 | 0.08 | 2.41 | 0.36 | 2.18 | 0.74 | 0.94 | 20.22 |
| 2005 | 2.36 | 0.10 | 0.79 | 0.66 | 2.01 | 0.15 | 0.23 | 0.15 | 1.68 | 0.74 | 2.26 | 5.11 | 16.23 |
| 2006 | 3.00 | 1.04 | 0.61 | 3.30 | 1.45 | 3.38 | Trace | Trace | 0.53 | 1.93 | 1.80 | 4.45 | 21.49 |
| 2007 | 0.36 | 1.93 | 1.88 | 0.66 | 0.76 | 1.14 | 0.18 | 0.81 | 1.45 | 0.53 | 2.87 | 1.35 | 13.92 |
| 2008 | 3.25 | 1.40 | 0.51 | 0.20 | 1.42 | 0.99 | Trace | 1.22 | 0.10 | 0.56 | 1.88 | 2.41 | 13.94 |
| 2009 | 2.92 | 1.63 | 2.03 | 0.99 | 0.46 | 0.41 | Trace | 0.10 | 0.15 | 1.98 | 1.42 | 1.80 | 13.89 |
| 2010 | 3.15 | 1.42 | 0.51 | 1.50 | 3.38 | 2.92 | 1.17 | 0.33 | 2.41 | 1.57 | 2.90 | 4.62 | 25.88 |
| 2011 | 1.35 | 0.08 | 2.21 | 0.64 | 3.10 | 0.99 | 0.30 | Trace | 0.13 | 1.96 | 0.30 | 0.25 | 11.30 |
| 2012 | 2.77 | 1.70 | 1.63 | 1.55 | 0.56 | 3.84 | 0.38 | Trace | 0.08 | 1.05 | 0.80 | 1.41 | 8.18 |
| 2013 | 0.41 | 0.23 | 0.99 | 0.76 | 4.06 | 3.45 | 0.03 | 0.61 | 1.07 | 0.97 | 0.91 | 0.18 | 13.67 |
| AVERAGE | 2.36 | 1.57 | 1.27 | 1.19 | 1.37 | 1.42 | 0.51 | 0.58 | 0.76 | 1.37 | 2.18 | 2.62 | 17.22 |
| NORMAL* | 2.39 | 1.78 | 1.45 | 1.40 | 1.30 | 1.30 | 0.58 | 0.46 | 0.79 | 1.24 | 2.41 | 3.05 | 18.14 |

* Normal is a 30-year average from 1980 to 2010.

2.2.2.4 Wind

On the Hanford Site, the prevailing wind direction is from the northwest all year long. The secondary wind direction is from the southwest. Summaries of wind directions indicate that winds from the northwestern quadrant occur most often during winter and summer. During spring and fall, the frequency of southwesterly winds increases, with a corresponding decrease in the northwesterly flow. Monthly average wind speeds are lowest during winter months, averaging ~3 m/s (~7 mi/hr), and highest during summer, averaging ~4 m/s (~9 mi/hr). Wind speeds well above average are usually associated with southwesterly winds. However, summertime drainage winds are generally northwesterly and frequently exceed 13 m/s (29 mi/hr). These winds are most prevalent over the northern portion of the Hanford Site. Figure 2-4 shows the 2010 wind roses (i.e., diagrams showing direction and frequencies of wind) measured at a height of 9 m (30 ft) for the 30 meteorological monitoring stations located at and around the Hanford Site. Figure 2-5 provides wind roses for the same stations from 1982 to 2006.

The annual average wind speed for meteorological records kept from years 1945 to 2004 is calculated to be ~3.4 m/s (7.6 mi/hr) at 15.2 m (50 ft) above the ground. During 2010, the average wind speed was 3.6 m/s (8.1 mi/hr), which was 0.2 m/s (0.4 mi/hr) above normal.

2.2.2.5 Severe Weather

Concerns about severe weather usually center on hurricanes, tornadoes, and thunderstorms. Fortunately, the occurrence of hurricanes and tornadoes is infrequent and their scale is generally small in the northwestern portion of the United States. According to the records of the HMS and the National Severe Storms Forecast Center database, only 24 separate tornadoes have occurred between 1916 and 1994 within 160 km (99 mi) of the Hanford Site. Only one of these tornadoes was observed within the boundaries of the Hanford Site itself (at the extreme western edge), and no damage resulted. The estimated probability of a tornado striking a point at the Hanford Site is 9.6×10^{-6} /yr. Hurricanes do not reach the interior of the Pacific Northwest.

Severe winds are associated with thunderstorms or the passage of strong cold fronts. The average occurrence of thunderstorms near the HMS is 10 per year. They are most frequent during the summer; however, they have occurred in every month. High-speed winds at the Site are more commonly associated with strong cold frontal passages. In rare cases, intense low-pressure systems can generate winds of near-hurricane force. The greatest peak wind gust was 130 km/hr (81 mi/hr), recorded at 15 m (49 ft) above ground level at the HMS. Extrapolations based on 35 years of observation indicate a return period of ~200 years for a peak gust in excess of 145 km/hr (90 mi/hr) at 15 m (49 ft) above ground level.

Figure 2-5. Hanford Meteorological Monitoring Network Wind Roses from 1982 to 2006 at the 9.1-meter (30-foot) Level.

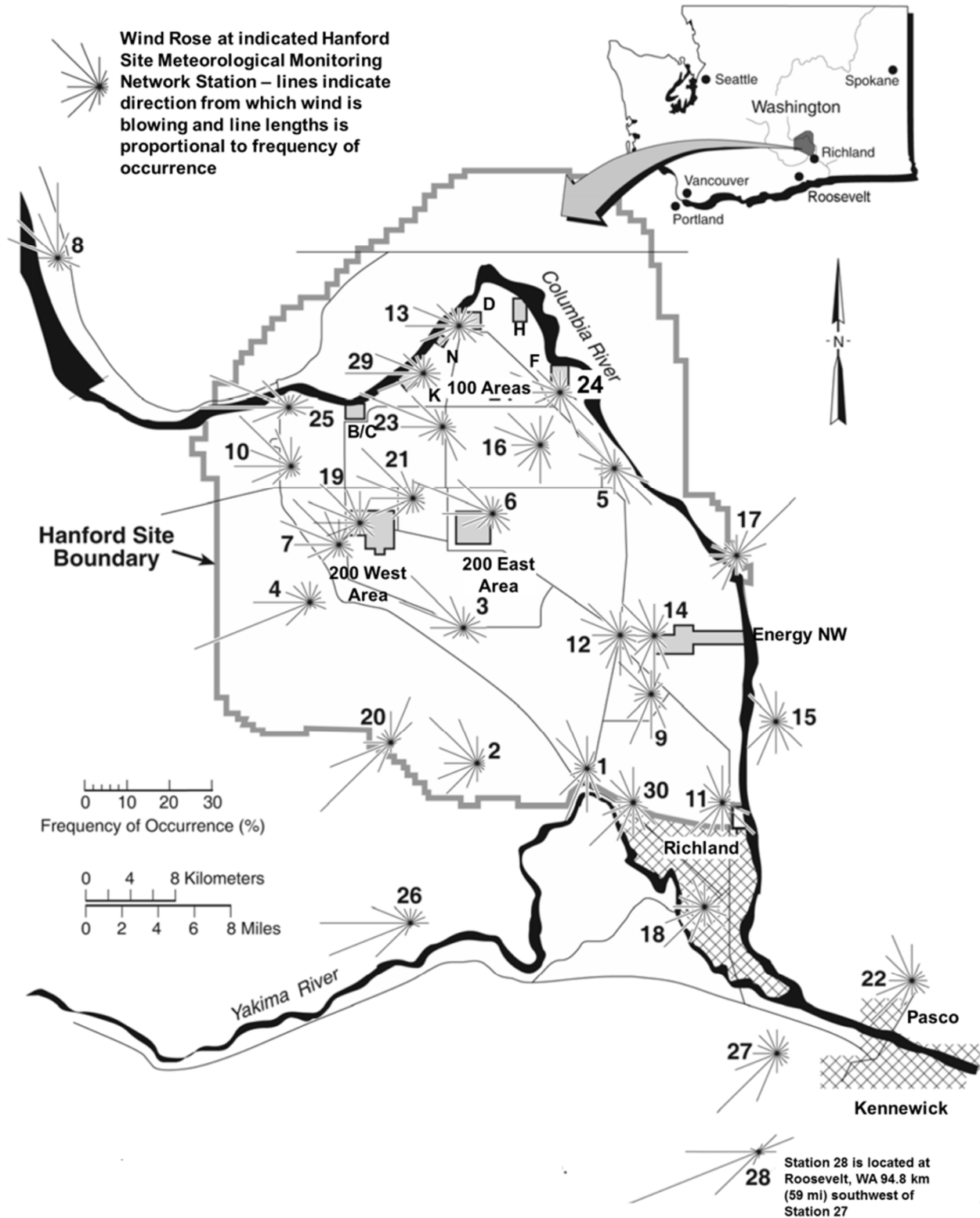

2.2.3 Geology, Seismology, and Volcanology

Since the Hanford Site started operating in the early 1940s, a large volume of information on the geology, seismology, and volcanology of the Site has been collected and evaluated. Over the last several years, the following data packages have been prepared to describe the geology of the Hanford Site in general and in detail around the IDF.

- DOE/RL-2002-39, *Standardized Stratigraphic Nomenclature for Post-Ringold-Formation Sediments Within the Central Pasco Basin*, Rev. 0. Released in 2002.
- PNNL-14586, *Geologic Data Package for 2005 Integrated Disposal Facility Performance Assessment*, Rev. 1. Released August 2005. Provides information on the geologic setting of the IDF and vicinity.
- PNNL-15237, *Geology of the Integrated Disposal Facility Trench*. Released June 2005. Provides information on the geologic setting of the IDF and vicinity.
- PNNL-17913, *Hydrogeology of the Hanford Site Central Plateau – A Status Report for the 200 West Area*, Rev. 1. Released August 2009. Provides information on the geologic setting of the Central Plateau where the IDF is located.
- SGW-48478, *Interpretation and Integration of Seismic Data in the Gable Gap*, Rev. 1. Released in 2012.
- ECF-HANFORD-13-0029, *Development of the Hanford South Geologic Framework Model, Hanford Site, Washington Fiscal Year 2016 Update*, Rev. 4. Released January 2017. Provides data and information related to the most current Geologic Framework Model (Hanford South) of the area.

Most of the geologic data were collected by (or used by) several projects between about 1980 and the present. Those projects include the Basalt Waste Isolation Project, the Skagit Hanford Nuclear Project, the Washington Public Power Supply System safety analysis, several PAs, and numerous regulatory-driven geologic and hydrologic characterizations, assessments, and monitoring projects.

The technical aspects of all of these projects, and thus the data, interpretations of the data, and conclusions, have been reviewed by one or more regulatory agencies and stakeholder groups including the NRC, the National Academy of Science, the Defense Nuclear Facilities Safety Board, the EPA, the U.S. Geological Survey, the Washington State Departments of Ecology and Health, the Oregon Department of Energy, and the Yakama, Nez Perce, and Wanapum Indian Nations and the Confederated Tribes of the Umatilla Reservation. The high level of oversight has helped ensure a rigorous understanding of bounding geologic, seismic, and volcanic risks.

This section provides a summary of the data, highlighting those aspects that are important to developing the conceptual model describing transport of contaminants away from the IDF to a

potential receptor. Section 2.2.3 focuses on the regional geologic framework and the associated larger-scale processes such as seismology and volcanism. Section 2.2.4 focuses on the Hanford Site geologic framework. Section 2.2.5 focuses on the geologic framework near the IDF.

2.2.3.1 Regional Geologic Framework

The Hanford Site lies within the Columbia Plateau (Figure 2-6), a broad plain situated between the Cascade Range to the west and the Rocky Mountains to the east, and is underlain by the Miocene Columbia River Basalt Group (CRBG) (Figure 2-7). The northern Oregon and Washington portion of the Columbia Plateau is often called the Columbia Basin because it forms a lowland surrounded on all sides by mountains. The low-relief plains of the Central Plains physiographic region and anticlinal ridges of the Yakima Folds region dominate the physiographic setting of the Hanford Site. In the central and western parts of the Columbia Basin and Pasco Basin where the Hanford Site is located, the basalt is underlain predominantly by Tertiary continental sedimentary rocks and overlain by late Tertiary and Quaternary fluvial and glacio-fluvial deposits. All these were folded and faulted during the Cenozoic Era to form the current landscape of the region.

The Columbia Basin is a structurally and topographically low area surrounded by mountains ranging in age from the late Mesozoic to Quaternary (Figure 2-6). The Columbia Basin is composed of two fundamental sub-provinces, the Palouse Slope and the Yakima Fold Belt (Figure 2-7). The Palouse Slope is a stable, undeformed area overlying the old continental craton that dips westward toward the Hanford Site. The Yakima Fold Belt is a series of anticlinal ridges and synclinal valleys in the western and central parts of the Columbia Basin. The edge of the old continental craton lies at the junction of these two structural sub-provinces and is currently marked by the Ice Harbor dike swarm of the CRBG east of the Hanford Site. The Blue Mountains sub-province of the Columbia River flood-basalt province is a northeast trending anticlinorium that extends 250 km from the Oregon Cascades to Idaho and forms the southern border of the Columbia Basin and the southern part of the Columbia Plateau.

2.2.3.2 Volcanology and Lava Flows

Two types of volcanic hazards have affected the Hanford Site in the past 20 million years. The hazards were (1) continental flood basalt volcanism that produced the CRBG and (2) volcanism associated with the Cascade Range. Several volcanoes in the Cascade Range are currently considered to be active, but activity associated with flood basalt volcanism has ceased.

The flood basalt volcanism that produced the CRBG occurred between 17 and 6 million years ago. Most of the lava was extruded during the first 2 to 2.5 million years of the 11-million-year volcanic episode. Volcanic activity has not recurred during the last 6 million years, suggesting that the tectonic processes that created the episode have ceased. The recurrence of CRBG volcanism is not considered to be a credible volcanic hazard.

Figure 2-6. Geologic Elements of the Pasco Basin Portion of the Columbia Basin, Washington.

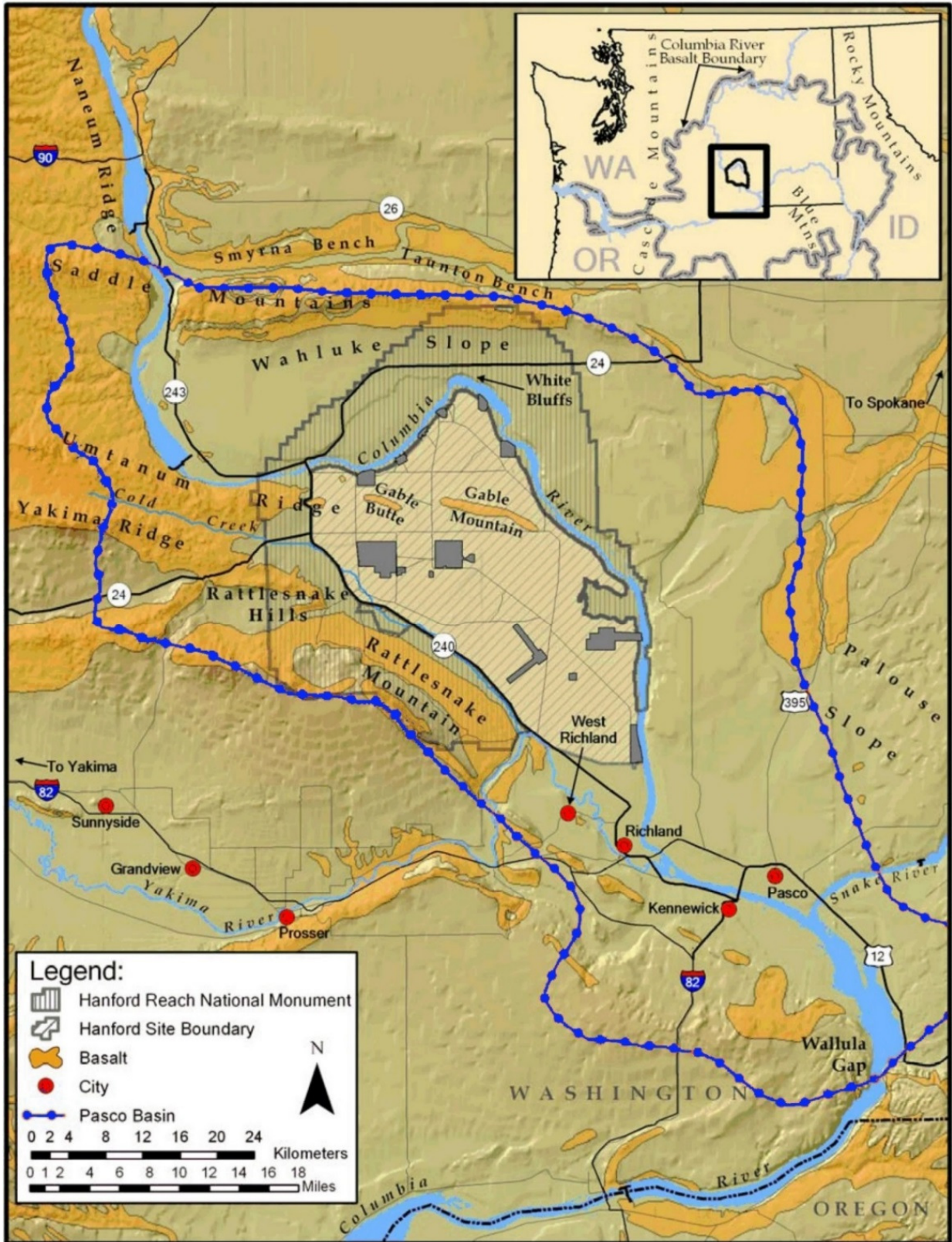
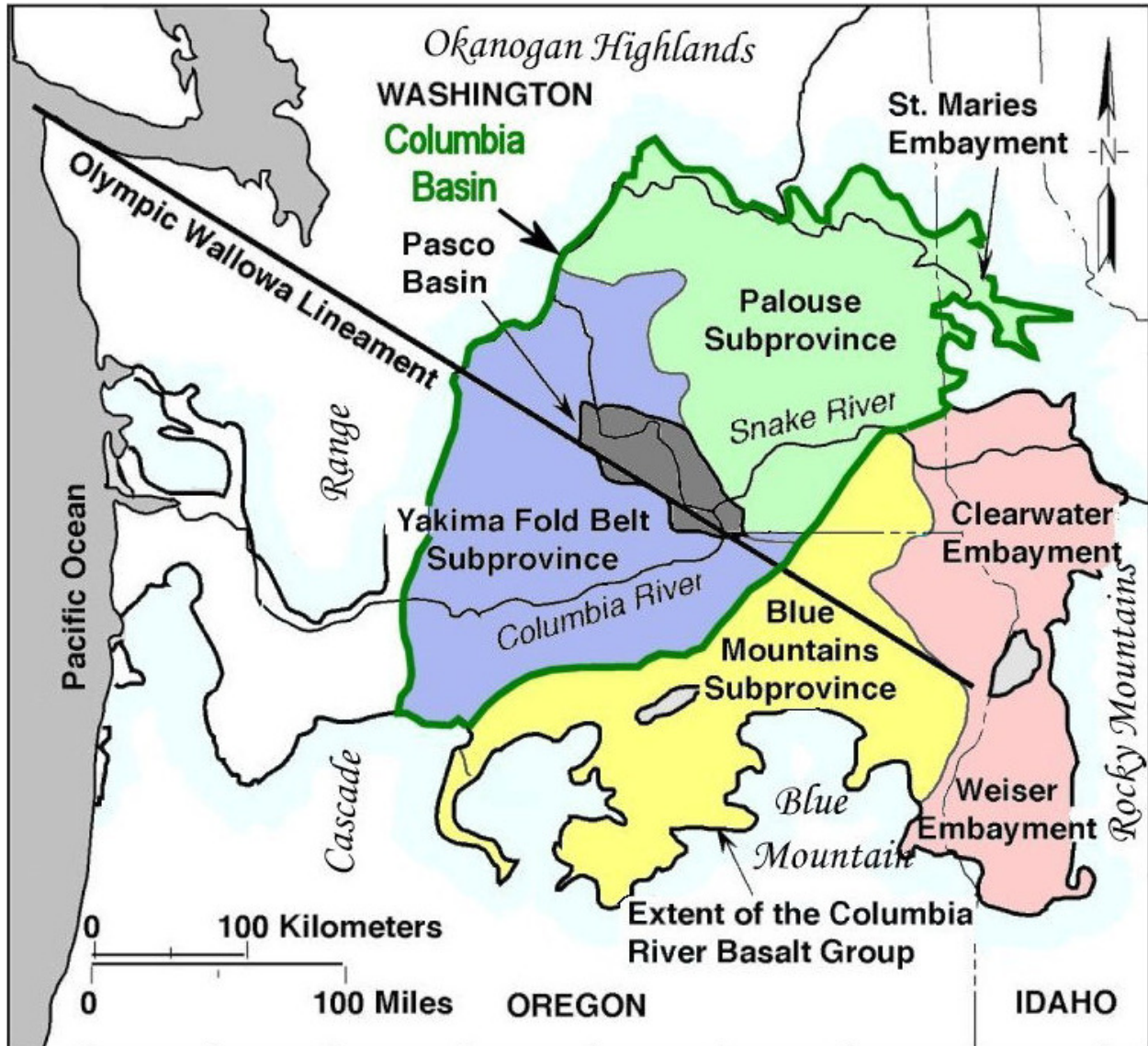

Figure 2-7. Geologic Setting of the Columbia Basin and Pasco Basin.



Volcanism in the Cascade Range was active throughout the Pleistocene Epoch and has remained active through the Holocene Epoch. The eruption history of the current Holocene Epoch best characterizes the most likely types of activity in the next 100 years. Many of the volcanoes have been active in the last 10,000 years, including Mount Mazama (Crater Lake) and Mount Hood in Oregon; and Mount Saint Helens, Mount Adams, and Mount Rainier in Washington. The Hanford Site is 150 km (~93 mi) from Mount Adams, 175 km (109 mi) from Mount Rainier, and 200 km (124 mi) from Mount Saint Helens, the three closest active volcanoes. At these distances, the deposition of tephra (ash) is the only potential hazard. Mount Saint Helens has been considerably more active throughout the Holocene Epoch than Mount Rainier or Mount Adams, which is the least active of the three. The Hanford Site is sufficiently distant from the Cascade Range volcanoes that hazards from lava flows, pyroclastic flows and surges, landslides, lahars, and ballistic projectiles are below a probability of concern.

Under the Hanford Site, basaltic lava deposits (CRBG) are over 4 km (13,000 ft) thick, spreading over portions of Idaho, Oregon, and Washington. The Columbia Basin encloses the CRBG. A depression in the lower part of the Columbia Basin is referred to as the Pasco Basin (Figure 2-7). The Pasco Basin is bounded by the Saddle Mountains to the north, Naneum Ridge to the west, Rattlesnake Hills to the south, and the Palouse Slope to the east; generally, the area north of where the Snake River flows into the Columbia River. Geographically, the ridges surrounding the Hanford Site and vicinity define the Pasco Basin, which contains Ringold Formation sediment from the ancestral Columbia River and sediment deposited by the Ice Age floods.

2.2.3.3 Crustal Folding

During and after the eruption of the lava flows, the Earth's tectonic forces buckled and folded the basalt in the western Columbia Basin into generally east-west trending, long, narrow ridges (anticlines), and intervening valleys (synclines). Collectively, this is identified as the Yakima Fold Belt.

2.2.3.4 Ancestral Columbia River Deposits

The ancestral Columbia River repeatedly changed its course over the past 15 million years, depositing gravel, sand, silt, and clay. Uplifting basalt ridges diverted the course of the Columbia River from a southerly direction (toward Goldendale) to an easterly direction (toward Wallula Gap) and left behind the Ringold Formation. Later regional uplift associated with the Cascade Mountains caused the river to cut through its own earlier deposits (the Ringold Formation) exposing the White Bluffs. Within the Hanford Reach, the Columbia River continues to erode the White Bluffs. Groundwater seepage from irrigation along the bluffs makes them unstable. Consequently, the White Bluffs are landsliding and sloughing into the Columbia River along much of the shoreline.

2.2.3.5 Ice Age Floods

During the Pleistocene, cataclysmic floods inundated the Pasco Basin several times when ice dams failed on the Clark Fork River that created glacial Lake Missoula with the most recent occurring 18,000 to 13,000 years ago. Current interpretations suggest as many as 40 flooding events occurred as ice dams holding back glacial Lake Missoula repeatedly formed and broke. In addition to larger major flood episodes, there were probably numerous smaller individual flood events. Deciphering the history of cataclysmic flooding in the Pasco Basin is complicated, not only because of floods from multiple sources but also because the paths of Missoula floodwaters migrated and changed course with the advance and retreat of the Cordilleran Ice Sheet.

Along with sedimentological evidence for cataclysmic flooding in the Pasco Basin, high-water marks and faint strandlines occur along the basin margins. Temporary lakes were created when flood waters were hydraulically dammed, resulting in the formation of the short-lived Lake Lewis behind Wallula Gap. High-water mark elevations for Lake Lewis, inferred from ice-rafted erratics on ridges, range from 370 to 385 m (1,214 to 1,263 ft) above sea level.

The sediment deposited by the cataclysmic flood waters has been informally called the Hanford formation because the best exposures and most complete deposits are found there. The coarse-grained flood facies is generally confined to relatively narrow tracts within or near flood channel ways. The plane-laminated sand facies, on the other hand, occurs as a broad sheet over most of the central basin.

2.2.3.6 Seismology

The historic record of earthquakes in the Pacific Northwest dates from about 1840. The early part of this record is based on newspaper reports of human perception of shaking and structural damage as classified using the Modified Mercalli Intensity (MMI) scale; the early record is probably incomplete because the region was sparsely populated. The historical record appears to be complete since 1905 for MMI V and since 1890 for MMI VI. Seismograph networks did not start providing earthquake locations and magnitudes of earthquakes in the Pacific Northwest until about 1960. A comprehensive network of seismic stations that provides accurate locating information for most earthquakes of magnitude greater than 2.5 on the Richter scale was installed in eastern Washington during 1969. Currently, measured seismic activity for the Hanford Site is reported quarterly and annually. Figure 2-8 provides summaries of known events at and around the Hanford Site between 1890 and 2005. In addition, an online database of seismic activity is maintained by Pacific Northwest Seismic Services (<https://pnsn.org/earthquakes>). A query of the database with a focus on a rectangular area around the Hanford Site 200 East and 200 West Areas indicates up to 78 earthquakes have been recorded in the vicinity of the IDF with a magnitude between -0.8 and 2.8.

Figure 2-9 provides a summary of known events near the IDF site since 1969 and shows the properties of the two largest recorded events in the vicinity (under 4 mi) of the IDF.

Three horizontal layers of stratigraphy related to seismicity exist at the Hanford Site and vicinity including the CRBG, the pre-basalt sediments, and the crystalline basement. About 75% of Hanford Site earthquake events originate in the CRBG layer. The pre-basalt sedimentary layer has been the origin of 8% of the events, and the crystalline basement has been the origin of 17% of these events.

The most frequent seismic occurrences at the Hanford Site are earthquake swarms (Figure 2-10) that consist of multiple small-energy events that fall within a small energy range and are constrained temporally (weeks to months) and spatially (5 to 10 km [3 to 6 mi] in length). Swarms tend to reoccur in particular locations, ~90% of individual earthquakes are at Richter scale magnitudes of 2 or less, and 70% to 80% of them occur at depths less than 4 km (2.5 mi) below ground surface (bgs).

Figure 2-8. Historical Earthquake Activity of the Columbia Basin, Washington, and Surrounding Areas.

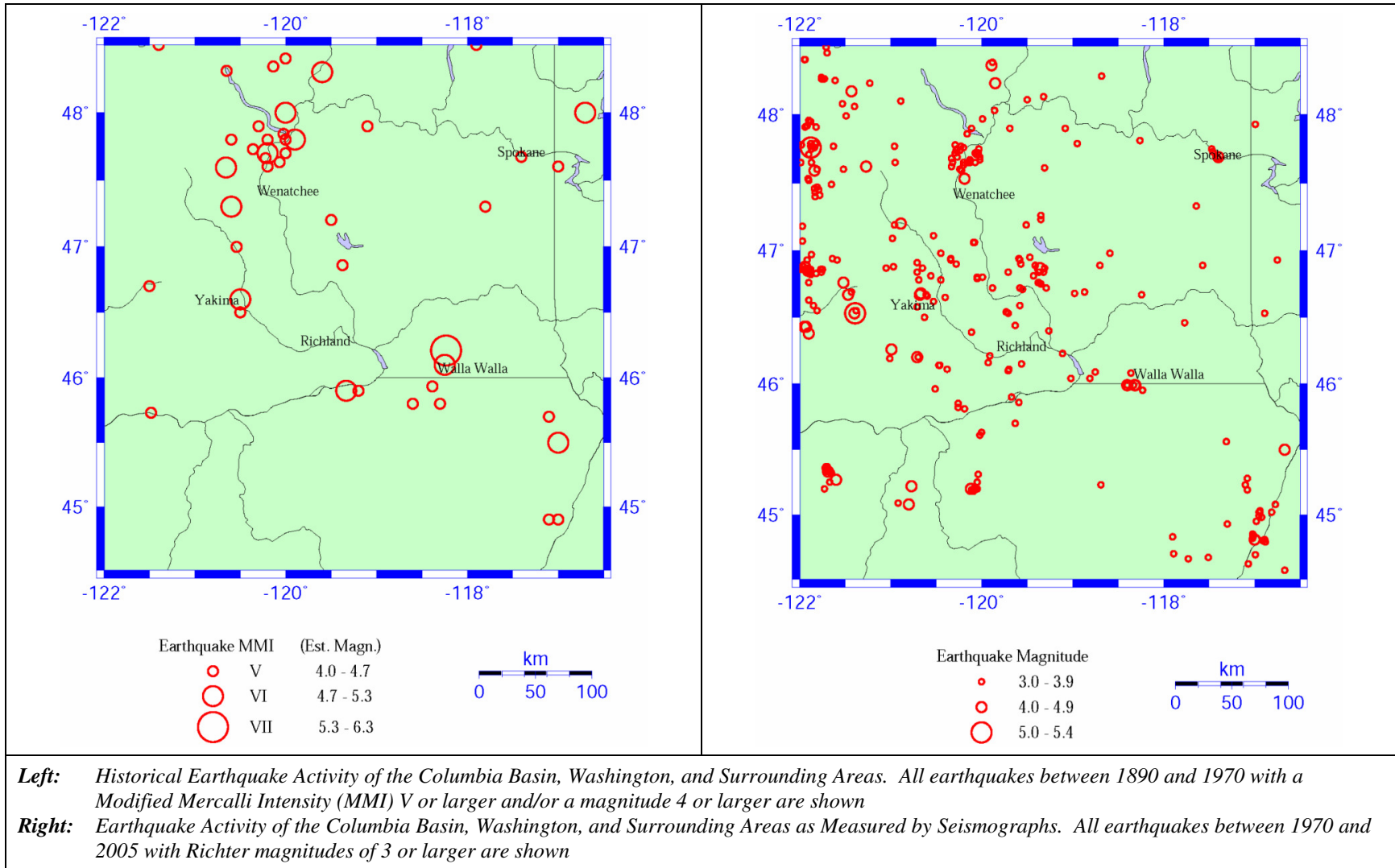
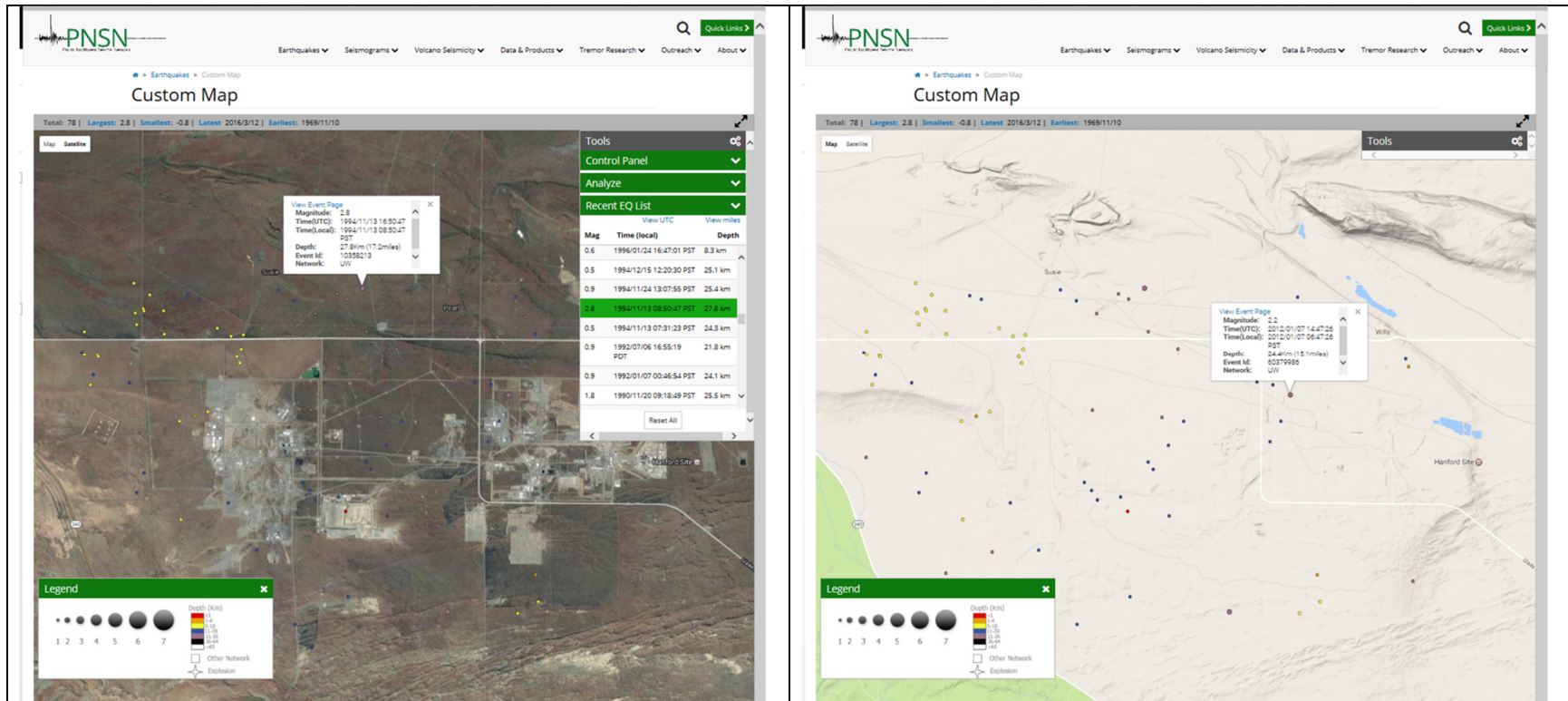
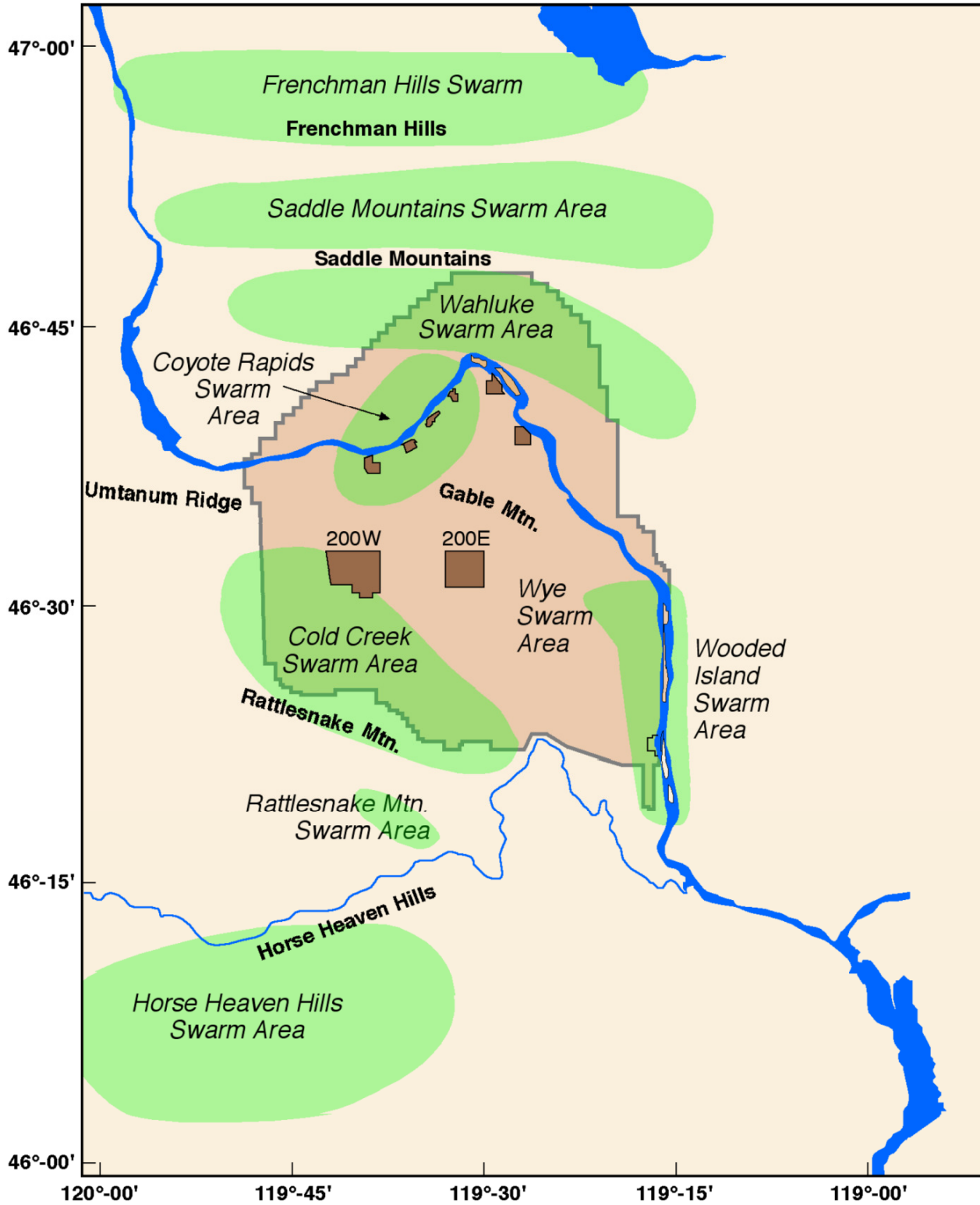

Figure 2-9. Map Showing the Location of Earthquakes Detected Since 1969 near the Integrated Disposal Facility Site.



Satellite (left) and Map (right) projection of seismic events in the vicinity of the Integrated Disposal Facility. Colors indicate depth, size indicates magnitude.

Figure 2-10. Earthquake Swarm Areas Near the Hanford Site.



Larger isolated earthquakes also occur nearby. The largest single event earthquake recorded near the Hanford 200 Area occurred in Milton-Freewater, Oregon, located ~113 km (70 mi) away in 1936 at a Richter magnitude of 5.75 and a maximum MMI of VII. The two next largest nearby earthquakes occurred north of the Hanford Site in 1917 and 1973 near Othello, Washington, ~48 km (30 mi) north of the 200 Areas with magnitudes above 4 on the Richter scale and MMI of V. The 1973 earthquake occurred ~1 km (0.6 mi) bgs. Since 1973, 80 small earthquakes (2.5 to 4.3 magnitudes) have been recorded within a radius of 90 km (56 mi) of the Hanford Site Central Plateau, the closest being a magnitude 3.3 event with the epicenter 8 km (5 mi) north of the 200 Areas. Earthquake depths vary for isolated events and have been estimated as deep as 30 km (~19 mi).

Greater magnitude earthquakes have been recorded at greater distances from the Hanford Site at the edges of the Columbia Plateau, along the coastal subduction zones to the west and in the Rocky Mountains to the east. The Columbia Plateau, which is made up of thick and extensive sequences of flood basalt layers in the Columbia River Group, extends well beyond the Hanford Site covering parts of eastern Washington, eastern Oregon, and Idaho. Notable events in these areas are the 2001 “Nisqually earthquake” in the Puget Sound (6.8 magnitude), an approximate magnitude 6.8 to 7.4 earthquake in north-central Washington in 1872 near Lake Chelan, the 1959 Hebgen Lake earthquake (7.5 magnitude) in western Montana, and the 1983 Borah Peak earthquake in eastern Idaho (7.3 magnitude).

The gross pattern of seismic activity around the Hanford Site is consistent with our understanding of regional tectonic characteristics of the Northwest. That is, the flood basalts form a large and relatively competent block of rock that is surrounded by numerous complex zones of active faults where large-scale stresses, imposed primarily by the ongoing subduction of the Pacific and Juan de Fuca Plates underneath the North American Plate, are mostly relieved. Consequently, relatively minimal stress relief occurs in the Columbia Plateau and earthquake energy is correspondingly small. This means that potential ground motion that accompanies these earthquakes is also relatively small.

Relative movement is commonly quantified as some fraction of gravitational acceleration (g) and has been usually correlated with earthquake magnitude. For the range of earthquake magnitudes suggested by data summarized above for the Hanford Site (<3 to 6), peak accelerations between <0.0017 and 0.18 g are proposed. The associated range of motion is generally imperceptible compared to clearly-felt movement that can result in minimal building damage. A probabilistic seismic hazard analysis estimated that a 0.1-g horizontal acceleration would occur every 500 years and a 0.2-g acceleration would occur every 2,500 years.

2.2.3.7 Subsurface Subsidence

Field and laboratory geotechnical studies that have been completed at Hanford reveal that there are no areas of potential surface or subsurface subsidence, uplift, or collapse at the Hanford Site, with the minor exceptions of the Cold Creek and Wye Barricade depressions, neither of which are close to the IDF. With the exception of the loose superficial wind-deposited silt and sand in some locations, the in-place soils are competent and form good foundations.

2.2.4 Hanford Site Geologic Framework

The previous section provided the regional geologic framework. This section provides a summary of the geologic structure and stratigraphy unique to the Hanford Site. Section 2.2.4.1 provides a detailed description of the geologic framework near the IDF.

2.2.4.1 Geologic Structure

The Cold Creek syncline (Figure 2-11) lies between the Umtanum Ridge-Gable Mountain uplift and the Yakima Ridge uplift and is an asymmetric and relatively flat-bottomed structure. The Cold Creek syncline began developing during the eruption of the CRBG and has continued to subside since that time. The 200 Areas lie on the northern flank, and the bedrock dips gently (approximately 5°) to the south. The deepest parts of the Cold Creek syncline, the Wye Barricade depression and the Cold Creek depression, are ~12 km (~7.5 mi) southeast of the 200 Areas and southwest of the 200 West Area, respectively (Figure 2-12).

The Wahluke syncline north of Gable Mountain is the principal structural unit that contains the 100 Areas. The Wahluke syncline is an asymmetric and relatively flat-bottomed structure similar to the Cold Creek syncline. The northern limb dips gently (approximately 5°) to the south. The steepest limb is adjacent to the Umtanum Ridge-Gable Mountain structure.

The 200 East Area is located on the eastern part of the Cold Creek bar, which is along the northern flank of the Cold Creek syncline (Figure 2-12). Another deep structural low, the Wye Barricade depression, developed along the Cold Creek syncline southeast of the 200 East Area. The May Junction fault is a normal fault that marks the western boundary of the depression.

The 200 East Area sits at the southern end of a series of secondary doubly-plunging anticlines and synclines that are associated with the Umtanum Ridge-Gable Mountain anticlinal structure. Waste Management Areas (WMAs) A-AX, B-BX-BY, and C in the 200 East Area lie near the southern flank of the closest secondary anticline. A fault was recently detected during drilling of seismic test boreholes at the WTP. The fault caused some displacement in the Pomona Basalt that lies beneath the Elephant Mountain Member but is not thought to have caused any displacement in younger basalts or overlying sediments.

2.2.4.2 Stratigraphy

The principal rocks exposed at the surface of the surrounding ridges are the CRBG and intercalated sedimentary rocks of the Ellensburg Formation. In the low-lying basins and valleys, these are overlain by younger sedimentary rocks of the Ringold Formation, Cold Creek Unit (CCU), and the Pleistocene cataclysmic flood deposits of the Hanford formation.

Columbia River Basalt Group and Ellensburg Formation: The Elephant Mountain Member is the uppermost basalt flow beneath the 200 Areas and much of the Hanford Site. Where folds and faults have formed basalt ridges, other flows from the Saddle Mountains, Wanapum, and Grande Ronde Formations are exposed.

Figure 2-11. Geologic Structures of the Pasco Basin and Vicinity.

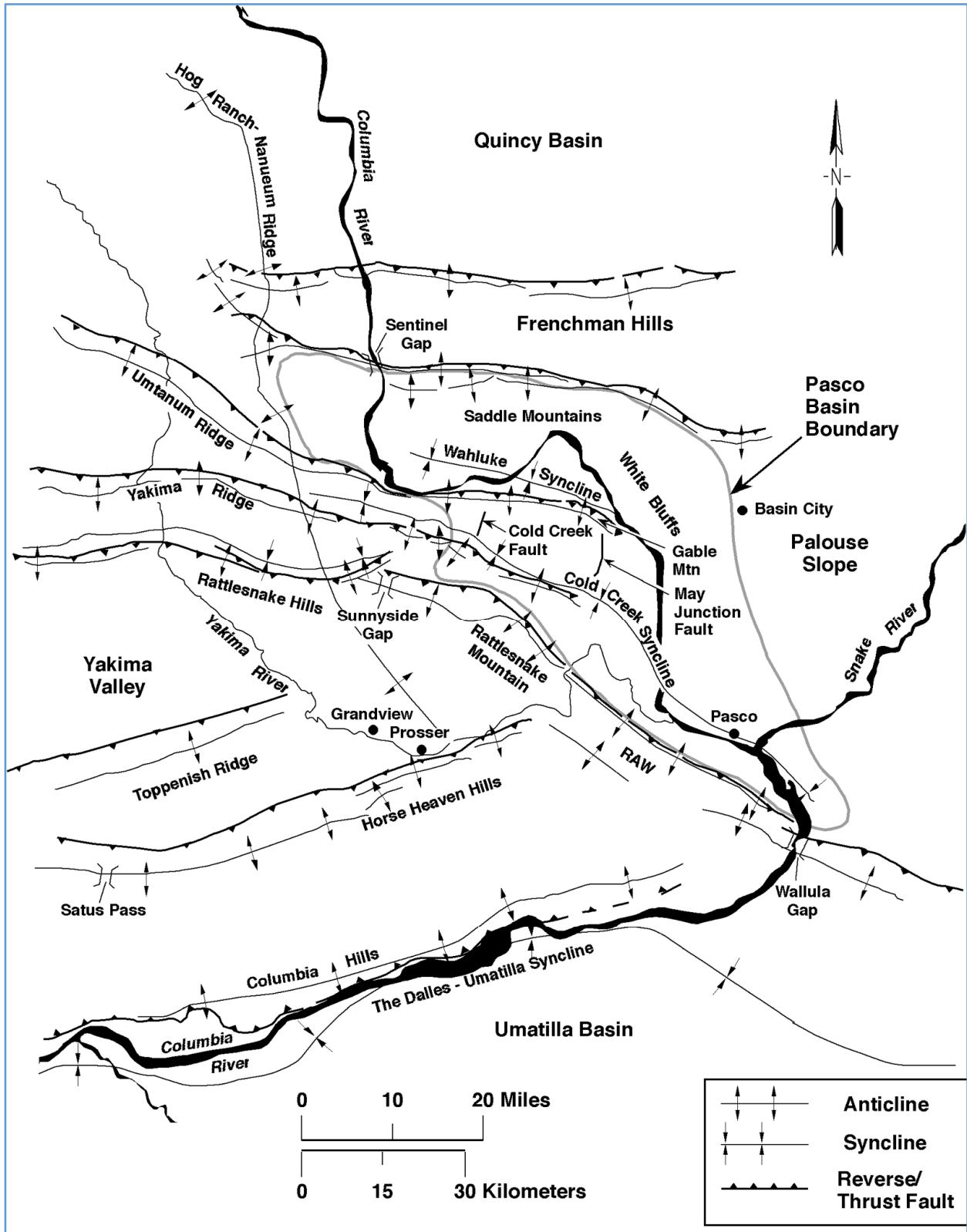
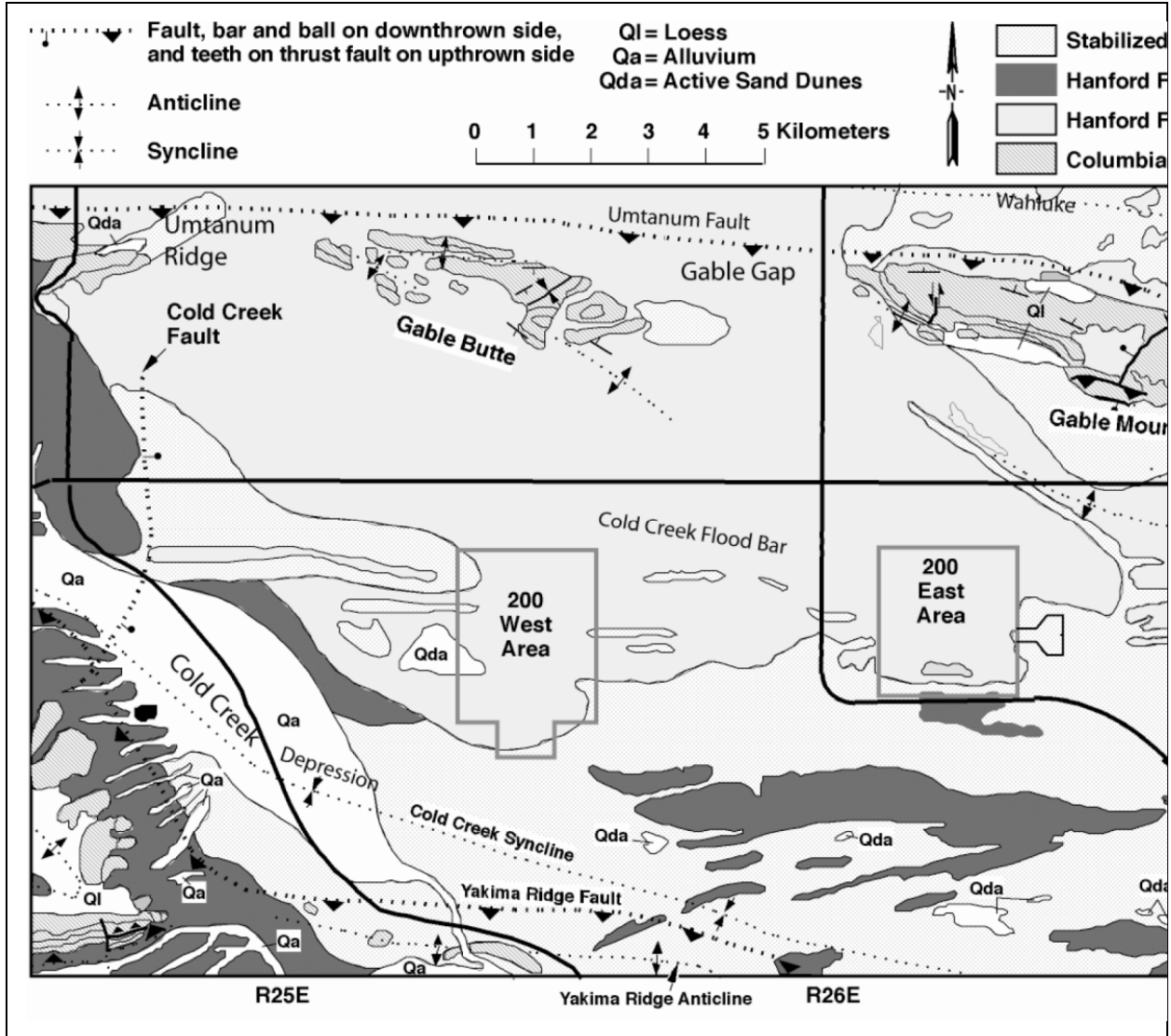

Figure 2-12. Geologic and Geomorphic Map of the 200 Areas and Vicinity.



The Ellensburg Formation is intercalated with and overlies the CRBG in the Pasco Basin and includes epiclastic and volcanoclastic sedimentary rocks. The upper Ellensburg Formation consists of sand and gravel marking mainstream deposits and sand, silt, and clay overbank deposits that are sandwiched between basalt flows. Along with the more permeable basalt flow bottoms and flow tops, these sediments form the uppermost confined basalt aquifer system beneath the Hanford Site. The upper, younger Ellensburg Formation interbedded with the Saddle Mountains Basalt reflects changes in river courses, with sediments from the Columbia River becoming dominant as developing anticlinal ridges pushed the Columbia River east and basalt flows pushed the Clearwater-Salmon system to the south. Relatively few boreholes in the 200 Areas penetrate the Ellensburg Formation. Those boreholes that do penetrate the Ellensburg Formation generally find tuffaceous siltstones and sandstones, with conglomerates marking ancient main river channels.

The uppermost basalt flow beneath the Central Plateau is the Elephant Mountain Member. The top of basalt surface dips to the southwest beneath the 200 West Area and to the south-southwest beneath the 200 East Area. Low-amplitude secondary folds such as the one to the northeast of the 200 East Area may occur throughout the area and have probably not been fully identified. Between the 200 East Area and Gable Gap to the north, the Elephant Mountain has been eroded to expose underlying basalt flows. There is also a suspected window eroded through the Elephant Mountain near the northeast corner of the 200 East Area.

Post-Columbia River Basalt Sediments: The Hanford Site and tank farms are situated on a sequence of Ringold Formation, CCU, and Hanford formation sediments overlying the CRBG. The upper Miocene to middle Pliocene record of the Columbia River system in the Columbia Basin is represented by the upper Ellensburg and Ringold Formations. Except for local deposits (e.g., the CCU), there is a hiatus (erosion or lack of sedimentation) in the stratigraphic record between the end of the Ringold Formation deposition (3.4 Ma) and the beginning of Pleistocene (1.6 Ma) time.

Ringold Formation: The Ringold Formation at the Hanford Site is up to 185 m (607 ft) thick in the deepest part of the Cold Creek syncline south of the 200 West Area and 170 m (558 ft) thick in the western Wahluke syncline near the 100 B Area. The Ringold Formation pinches out against the Gable Mountain, Yakima Ridge, Saddle Mountains, and Rattlesnake Mountain anticlines. It is largely absent in the northern and northeastern parts of the 200 East Area. It consists of semi-indurated clay, silt, pedogenically-altered sediment, fine- to coarse-grained sand, and granule to cobble gravel. Ringold Formation strata typically are below the water table on the Hanford Site, and the textural variations influence groundwater flow.

In the Pasco Basin, the lower half of the Ringold Formation, the member of Wooded Island, is the main unconfined aquifer under the Hanford Site and contains five separate stratigraphic intervals dominated by the fluvial gravel facies. These gravels, designated units A, B, C, D, and E, are separated by intervals containing deposits typical of the overbank and lacustrine facies. In the 200 Areas, only fluvial gravel units A and E occur. Between these two gravel units in many places is the lowermost of the fine-grained sequences, designated the lower mud sequence. Fluvial gravel units A and E correspond to the lower basal and middle Ringold Formation units, respectively.

The upper part of the Ringold Formation, informally called the member of Taylor Flat, consists of the sequence of fluvial sands, overbank deposits, and lacustrine sediments overlying unit E. The fluvial sand facies is the principal facies of the upper part under the tank farms at the Hanford Site.

Cold Creek Unit: The CCU includes all material underlying the Hanford formation, overlying the Ringold Formation in the vicinity of the 200 West Area, and may extend over most of the central Pasco Basin. The CCU distinguishes itself from the Hanford and Ringold formations because it was formed when the Ringold Formation was eroding and relatively little was being deposited at the Hanford Site. This subunit is found locally in the Cold Creek syncline in the subsurface.

The CCU is laterally discontinuous and overlies the tilted and truncated Ringold Formation in an unconformable relationship in the western Cold Creek syncline in the vicinity of the 200 West Area. To the east, the pre-Missoula gravels replace the calcrete and silt-dominated subunits of the CCU. The CCU appears to be correlative to other side stream alluvial, eolian, and pedogenic deposits found near the base of the ridges bounding the Pasco Basin on the north, west, and south. These sedimentary deposits are inferred to have a late Pliocene to early Pleistocene age on the basis of stratigraphic position and magnetic polarity of interfingering loess units.

Distribution of the CCU depends in part on erosion and weathering of the underlying Ringold Formation and post-depositional erosion by the Ice Age floods. The thickness of the Cold Creek deposit ranges from 0 to 20 m (0 to 66 ft). Locally the CCU contains very hard rock that formed as precipitation evaporated and left behind minerals forming what geologists call caliche or hardpan. This layer can influence contaminant migration by slowing its rate of downward movement and potentially diverting contaminants laterally. However, CCU as described above is largely absent from the 200 East Area.

Hanford Formation: The Hanford formation is the informal name given to all glacio-fluvial deposits from cataclysmic Ice Age floods found in the Pasco Basin. Sources for floodwaters included glacial Lake Missoula, and ice-margin lakes that formed around the margins of the Columbia Plateau and Lake Bonneville. On average, interglacial conditions lasting ~50,000 years have been separated by major glacial advances, also averaging ~50,000 years. To date, Ice Age flood deposits from only four of the major glacial events that occurred between 1 million and 13,000 years ago are identified within the Pasco Basin. Evidence to support the other major glacial cycles in the Pasco Basin either are masked or have been destroyed by subsequent Ice Age floods.

When the Ice Age floodwaters entered the Pasco Basin, they quickly became impounded behind Wallula Gap, which was too restrictive for the volume of water involved. Floodwaters formed temporary lakes with shorelines up to 381 m (1,250 ft) in elevation. The lakes lasted not more than a few days. The deposits that were left after the floodwater receded, known as the Hanford formation, blanket low-lying areas over most of the Hanford Site. These Ice Age floods created Cold Creek bar, a giant, streamlined deposit of gravel, sand, and silt that extends for 19.3 km (12 mi) downstream of Umtanum Ridge. Gravel-dominated deposits, laid down under the strongest flood currents, are generally restricted to the north side of the bar. At the south end of the bar, where flood currents were gentler, interbedded sand and silt deposits were laid down. In between these two areas deposits of predominantly sand accumulated, which includes the area beneath 241-C Tank Farm.

The Hanford formation consists of mostly unconsolidated sediments that cover grain sizes from pebble to boulder gravel, fine- to coarse-grained sand, silty sand, and silt. The formation is further subdivided into gravel-, sand-, and silt-dominated facies, which transition into one another laterally with distance from the main, high-energy, flood channels. Beneath much of the Hanford Site, the Hanford formation has been locally subdivided into several informal subunits. The Hanford formation is subdivided in the 200 East and West Areas into three basic units: H1, H2, and H3. H1 is described as consisting of a gravel facies-dominated interval in the upper part of the formation throughout much of the 200 East and West Areas. Unit H2 is

described as a predominantly sand facies-dominated unit, which increases in predominance within the formation from north to south across the same area. The H3 unit is generally described as a mixed sand and gravel facies unit found comprising the lower part of the formation in much of the 200 East Area, and possibly locally in the 200 West Area.

Furthermore, five paleochannels (A through E) were identified running through the Central Plateau that are filled with coarse-grained, highly-permeable flood deposits of the Hanford formation. These paleochannels may have initially formed during Ringold time, and if so, were further deepened during cataclysmic flooding which removed all Ringold-age deposits from the channel. Paleochannel D, which has a remnant of Ringold Formation along its east side, might be an example of a Ringold-age channel that was cut deeper during Ice Age flooding. Paleochannel D runs from the northwest corner through to the southeast corner of 200 East Area.

Holocene Surficial Deposits: Holocene surficial deposits consist of silt, sand, and gravel that form a thin layer across much of the Hanford Site. These sediments were deposited by a combination of eolian and alluvial processes.

2.2.4.3 Clastic Dikes

Clastic dikes are found in the Hanford formation and locally in other sedimentary units. Clastic dikes are vertical to sub-horizontal fissures filled by multiple layers of unconsolidated sand, silt, clay, and minor gravel aligned parallel to sub-parallel to dike walls. Clastic dikes range in vertical extent from 0.3 m to 55 m (1 ft to 180 ft). In cross-section, clastic dikes range from 1 millimeter to 1.8 m (0.04 in. to 5.91 ft) in thickness, and in a plan view, clastic dikes extend up to 100 m (328 ft) along strike. Clastic dikes form a branching pattern, that in a plan view forms polygons many feet across. Where the dikes intersect the ground surface, a feature known as patterned ground is observed. Patterned ground features are most abundant when Hanford formation sand-dominated and silt-dominated facies are at or near ground surface. The clastic dikes identified during construction of the IDF are discussed in Section 2.2.6.

2.2.5 Integrated Disposal Facility Geologic Framework

This section presents the geologic framework representation in the area around the IDF. This section focuses on the framework representation of the more significant hydrostratigraphic units that affect fate and transport of contaminants in the vadose zone beneath the IDF and the alluvial aquifer beneath and downgradient of the IDF.

2.2.5.1 Hydrostratigraphy and Geologic Features at the Integrated Disposal Facility

Several boreholes have been drilled around the IDF over the past 20 years to characterize the vadose zone and upper portion of the alluvial aquifer near the IDF, with a focus on characterizing the lithologic characteristics of the Hanford formation. The Hanford formation near the IDF consists of an upper, predominantly sandy sequence and a lower predominantly gravel sequence, referred to as the H2 unit and H3 unit respectively in subsequent investigations. The water table indications on these figures are based on the observed depth to water identified when the holes were drilled, i.e., 1994 to 2005 time frame. The hydrostratigraphic units encountered in the boreholes around the IDF are summarized below.

Columbia River Basalt Group. The youngest lava flows of the CRBG at the 200 East Area are those of the 10.5-million-year old Elephant Mountain Member. The Elephant Mountain Member underlies the entire 200 East Area and forms the base of the unconfined aquifer. No erosional windows are known or suspected to occur in the IDF site area. The top of the CRBG ranges between 280 ft above sea level across the northern boundary of the IDF site to approximately 200 ft above sea level across the southern boundary of the IDF site.

Ringold Formation. The Ringold Formation consists of fluvial and lacustrine sediments deposited by the ancestral Columbia and Clearwater-Salmon river systems between ~3.4 and 8.5 million years ago. The Ringold consists of five separate fluvial gravels (conglomerate) units in the Hanford area designated (from bottom to top) as units A, B/D, C, and E. Fine-grained deposits typical of overbank and lacustrine environments separate the gravel units. The lowermost of the fine-grained sequences is designated the lower mud unit. Only gravel Units A and E are present beneath the 200 East Area.

Because few boreholes penetrate much of the entire Ringold Formation at the IDF site, data are limited. The Ringold Formation reaches a maximum thickness of 285 ft (87 m) on the west side of the IDF site and thins eastward. The deepest unit encountered is the lower gravel, Unit A. Lying above Unit A is the lower mud and overlying the lower mud is an upper gravel, Unit E. The upper Ringold (sand and silt of the member of Taylor Flat) is not present at the IDF site but is present east of the site.

Ringold Unit A overlies the CRBG and underlies the lower mud. Only three boreholes fully penetrated Unit A in the study area. Unit A is 19 m (61 ft) thick on the west side of the IDF site but pinches out to the northeast. Unit A is sandy gravel consisting of both felsic and basaltic rocks. There are occasional yellow to white interbedded sand and silt with silt and clay lenses. Although the entire unit appears to be partially cemented, the zone produced abundant water in borehole 299-E17-21.

Ringold Lower Mud overlies the Ringold Unit A. A maximum of 19 m (61 ft) of the lower mud was encountered at the IDF site. The uppermost part (1.2 m [~4 ft]) consists of a yellow sandy to silty mud. The silty mud grades downward into 10 m (~34 ft) of blue mud with zones of silt to slightly silty mud. The blue mud, in turn, grades down into 7 m (23 ft) of brown silty mud with organic rich zones and occasional wood fragments. The lower mud, like Unit A, is absent in the center of the IDF site.

Ringold Unit E overlies the lower mud and underlies the Hanford formation. Unit E is as much as 15 m (50 ft) of sandy gravel to gravelly sand with scattered large pebbles and cobbles up to 10 in. in size. The gravel consists of both felsic and basaltic clasts, which are well rounded with a sand matrix supporting the cobbles and pebbles. Cementation of this unit ranges between slight and moderate. The upper contact of Unit E is not easily identified at the IDF site. In the western part of the study area, unconsolidated gravels of the Hanford formation directly overlay the Ringold Unit E gravels, making exact placement of the contact difficult. In the central and northeast part of the area, Unit E is interpreted to have been eroded. Unconsolidated gravels and sands typical of the Hanford formation replace them.

Upper Ringold (Member of Taylor Flat). The upper Ringold is not present at the IDF site but has been tentatively identified in the southeast corner of 200 East Area in borehole 299-E37-47A. These sediments pinch out or were eroded before reaching the IDF site.

Unconformity at Top of Ringold Formation. The surface of the Ringold Formation is irregular in the IDF site area. A northwest-southeast trending erosional channel is centered along the northeast portion of the site. The deepest portion near boreholes 299-E24-7 and 299-E24-21 is in the northern portion of the IDF site. This trough is interpreted to be a smaller part of a much larger trough under the 200 East Area resulting from scouring by the Missoula floods or post-Ringold fluvial incision prior to the Missoula floods.

Hanford Formation. The Hanford formation is as much as 380 ft (116 m) thick in and around the IDF site. It thickens in the erosional channel cut into the Ringold Formation and thins to the southwest along the margin of the trough. The Hanford formation reaches its greatest thickness along a northwest-southeast trending trough under the eastern part of the IDF site. The Hanford formation consists of poorly-sorted pebble to cobble gravel and fine- to coarse-grained sand, with lesser amounts of interstitial and interbedded silt and clay. The characteristics of the Hanford gravel (H3) and sand (H2) sequence observed from the IDF boreholes are described below.

Basal Gravel Sequence. The lowermost part of the Hanford formation encountered in the IDF site consists of the gravel-dominated facies. At the northeast end of the IDF site, the Hanford gravel sequence is over 33 m (109 ft) thick in borehole 299-E24-21 and thins to the southwest (88 ft [27 m] thick in borehole 299-E17-21). The lower gravel decreases in elevation across the IDF site. Drill core and cuttings from these boreholes indicate that the unit is clast-supported pebble- to cobble-gravel with minor amounts of sand in the matrix. The cobbles and pebbles are almost exclusively basalt with no cementation. The gravel is interpreted to be Missoula flood gravels deposited in the erosional channel carved into the underlying Ringold Formation. The southwest part of the IDF site lies atop the western margin of this channel.

Sand-Dominated Sequence. The upper portion of the Hanford formation ranges from 82 to 86 m (270 to 283 ft) of fine- to coarse-grained sand with minor amounts of silt and clay and some gravelly sands. The texture of the sand-dominated facies changes across the IDF site reflecting a higher-energy environment for the floodwater to the northeast and east part of the site. The percentage of gravel and sand increase from the west (borehole 299-E19-1) to the northeast (borehole 299-E24-4). The percentage of sand in borehole 299-E19-1 is around 85% but the percentage of sand increases to over 90% at the expense of silt and mud in boreholes 299-E18-4, 299-E24-7 and 299-E24-21. Borehole 299-E24-4 lies northeast of the IDF site and lies in the main part of the channel where there is a decrease in the sand content and an increase in the gravel content.

Paleosols. Three paleosols (soils) were identified in the sand-dominated facies core and one gravel unit beneath the IDF. The paleosol horizons represent quiet time intervals when no sediments were deposited and soil development took place. They are interpreted to represent periods of non-deposition between Missoula flood depositions. The paleosols have abrupt upper

contacts and less well-defined lower contacts. The paleosols are typically 4 to 6 in. thick, bioturbated, a lighter color than the surrounding sediments, and slightly higher moisture content.

Eolian Unit. Holocene surficial deposits consist of silt, sand, and gravel that form a veneer less than 4.9 m (16 ft) thick atop much of the Hanford Site. These sediments were deposited by wind and local flood processes. The eolian unit is composed of fine- to coarse-grained sands with abundant silt, as layers and as material mixed with the sand. Eolian deposits cover the southern part of the new IDF disposal site. Borehole 299-E17-21 was sited on a stabilized sand dune.

Soils. The following soils are found in the IDF area.

- **Burbank Loamy Sand.** This soil is dark-colored, coarse-texture soil underlain by gravel. Surface soil is usually ~40 cm (16 in.) thick but can be up to 76 cm (30 in.) thick. Gravel content of the subsoil ranges from 20 to 80%.
- **Ephrata Sandy Loam.** The surface is dark colored and subsoil is dark grayish-brown medium-texture soil underlain by gravelly material, which may continue for many feet.
- **Quincy Sand (formerly Rupert Sand).** This soil is brown to grayish-brown coarse sand grading to dark grayish-brown at about 90 cm (35 in.). Rupert sand developed under grass, sagebrush, and hopsage in coarse sandy alluvial deposits that were mantled by wind-blown sand.

Clastic Dikes. Clastic dikes are vertical to subvertical sedimentary structures that cross cut normal sedimentary layering. Clastic dikes typically occur in swarms and occur as regularly-shaped polygonal patterns, irregularly-shaped polygonal patterns, preexisting fissure fillings, and random occurrences. Dikes in irregular-shaped polygon networks generally are crosscutting in both plane and cross-section, resulting in extensive segmentation of the dikes. In general, a clastic dike is composed of an outer skin of clay with coarser infilling material. Clay linings are commonly 0.03 mm to 1.0 mm thick, but linings up to about 10 mm are known. The width of individual infilling layers range from as little as 0.01 mm to more than 30 cm and their length can vary from about 0.2 m to more than 20 m. Infilling sediments are typically poor- to well-sorted sand, but may contain clay, silt, and gravel.

A clastic dike was encountered during the drilling of well 299-17-24 between 155.5 ft and 157.5 ft. Two clastic dikes were mapped in the IDF trench. One clastic dike crosses the trench from the south wall to the north wall and nearly bisects the IDF trench. This clastic dike is ~1.2 m (4 ft) wide and trends approximately 35 degrees east of north. The second clastic dike is exposed along the west wall and trends approximately 70 degrees west of north. Both dikes exposed in the excavation are sheeted dikes composed of layers of sand segments bounded by layers of silt/clay. These dikes mainly cross cut the stratigraphic units exposed in the trench, except locally where the dikes trend parallel to the bedding forming sill-like features.

The north-south clastic dike exposed in the trench was mapped on the south and north walls and the floor of the trench. The dike is nearly vertical and its base is not exposed. The width remains nearly the same along its mapped length (~1.2 m [4 ft]), varying by less than 0.1 m

(0.5 ft). The primary clastic dike is composed of eight to nine segments on the north wall and five to six segments on the south wall. A segment is defined as silty sand to coarse sand bounded by clay margins or skins. The interior segments of the clastic dike are composed of sand having a brown color but the exterior segment on both sides is composed of dominantly black basaltic sand. Overall, the sand component of the dike is compacted to partly-cemented sand. This results in the dike being more resistant than the surrounding sediment in the trench. When rain or snow fell in the trench during the time the trench was being mapped, the clastic dike remained relatively dry compared to the host sediment. This suggested that the dike had a much lower permeability than the host sediment, probably due to the cement. The vertical trace of the clastic dike up the walls of the trench is broken by sill-like deflections. This generally occurs where the nature of the host sediment changes (e.g., textural change from fine to coarse). For example, on the south wall the clastic dike is deflected about 1 m (3 ft) to the west at the contact between units Qh1 and Qh2.

The west-wall clastic dike is exposed only along the west wall and cannot be traced more than several meters east along the IDF trench floor. It does not intersect the north wall-south wall clastic dike. Two branches of this clastic dike intersect the main dike. The southernmost clastic dike branch trends 35 degrees east of north and the northernmost clastic dike branch trends about 45 degrees east of north but intersects the main dike ~3 m (10 ft) higher up the trench wall. A second deflection of the clastic dike occurs ~3 m (10 ft) higher than the first deflection. The deflection is to the north following the clastic dike from the floor of the trench to the top of the trench. At this deflection, the clastic dike appears to feed a sill that can be traced along the west wall and part of the north wall. The clastic dike can be traced upward to the eolian sediments. Near the floor of the trench the clastic dike is ~1.2 m (4 ft) wide and narrows slightly upward. The primary clastic dike is composed of six segments. Like the north-south clastic dike, the interior segments of the clastic dike are composed of brown sand but the exterior segment on both sides is composed of dominantly basaltic sand. Mapping relations suggest that the exterior basaltic sand is the youngest portion of the dike. Unlike the north-south clastic dike, this clastic dike appears to originate in the sediment exposed along the floor of the trench. The clastic dike can be traced ~4 m (13 ft) out onto the floor of the trench but it then appears to end. The surface of the floor in the western part of the trench has many irregular clastic dikes that can be traced less than a meter. In addition, the sediment layers appear to be irregular as if the sediment had rapidly dewatered and the sediment backfilled the void space.

2.2.6 Hydrology

This section presents the summary of the hydrology/hydrogeology (water and soil characteristics) of the Hanford Site, focusing on surface water, recharge, characteristics of the unsaturated zone or vadose zone and the saturated zone or groundwater. Due to waste disposal operations at the Hanford Site, the hydrology of the Site has been studied and monitored in detail. Therefore, the information presented in this section will primarily be a summarization of previous work highlighting those characteristics that affect the IDF PA.

2.2.6.1 Surface Water

Surface water at the Hanford Site includes the Columbia River, Columbia Riverbank seepage, springs, and ponds. Intermittent surface streams, such as Cold Creek, may also contain water

after large precipitation or snowmelt events. In addition, the Yakima River flows along a short section of the southern boundary of the Hanford Site (Figure 2-13), and there is surface water associated with irrigation east and north of the Site.

Figure 2-13. Surface Water Features including Rivers, Ponds, Major Springs, and Ephemeral Streams on the Hanford Site, Washington.

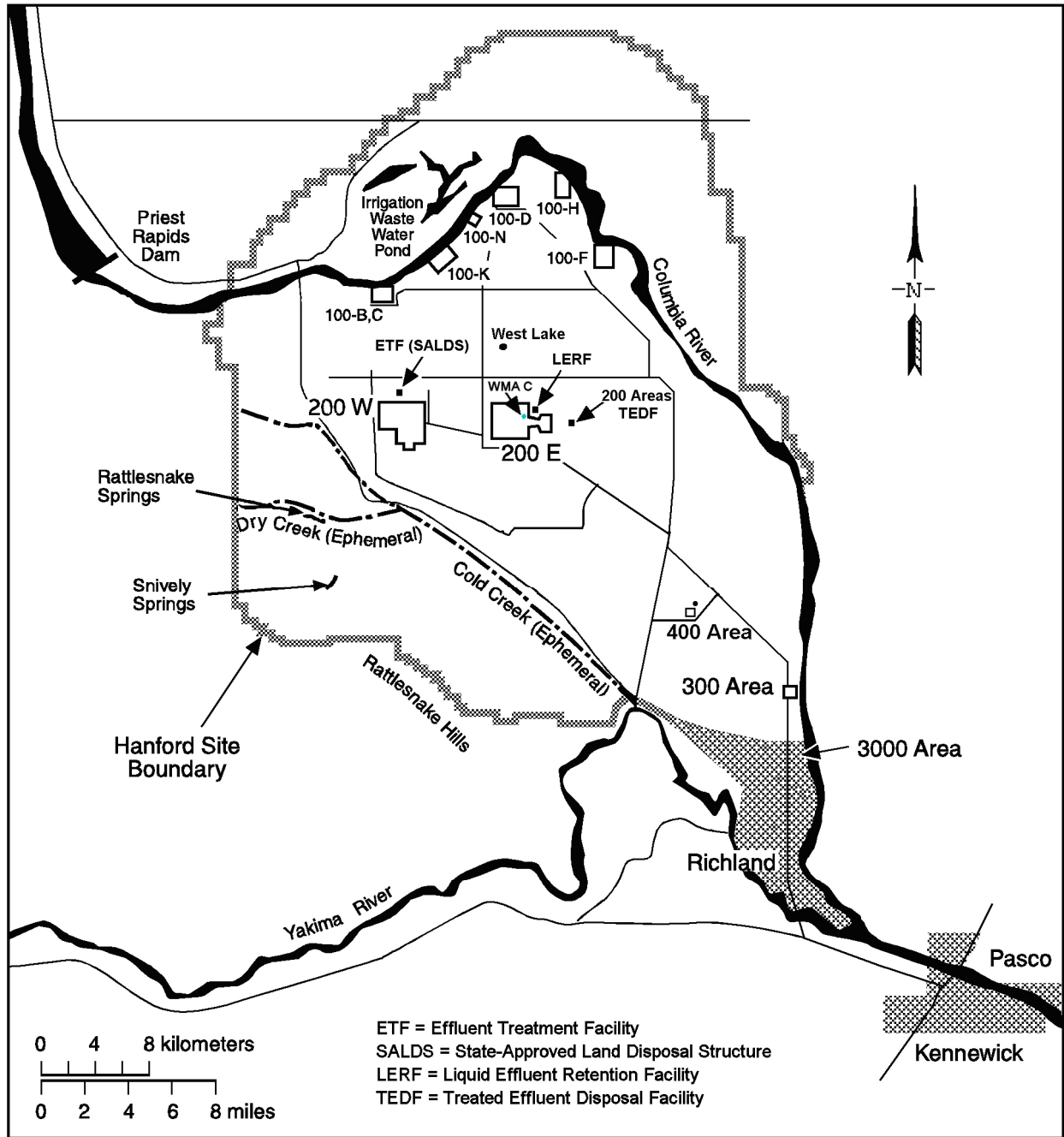

S9508017.4

2.2.6.2 Columbia River

The Columbia River is the second largest river in the contiguous United States in terms of total flow and is the dominant surface-water body on the Hanford Site. The original selection of the Hanford Site for plutonium production and processing was based, in part, on the occurrence of abundant water provided by the Columbia River. The existence of the Hanford Site has precluded development of this section of the river. The IDF is located ~11.2 km (7 mi) from the Columbia River.

The Columbia River originates in the mountains of eastern British Columbia, Canada, and drains an area of ~680,000 km² (262,480 mi²) en route to the Pacific Ocean. Columbia River flow at the U.S. Geological Survey gauging station, located just west of the Hanford Site boundary (located downstream of Priest Rapids Dam), has been measured during a 90-year period from 1917 to 2007. Daily average flows during this period ranged from 570 to 19,540 m³/s (20,000 to 690,000 ft³/s). The lowest and highest flows occurred before the construction of upstream dams. During the 10-year period from 1997 through 2006, the average flow rate was ~3,300 m³/s (116,500 ft³/s). The river elevation is ~121 m (396 ft) near the 100 B and C areas and ~105 m (343 ft) at the 300 Area.

The Columbia River flows through the northern part and along the eastern border of the Hanford Site with these areas of the Hanford Site draining into the Columbia River. Except for the Columbia River estuary, the only unimpounded stretch of the river in the United States is the Hanford Reach, which extends from Priest Rapids Dam (located upstream of the Site) downstream ~82 km (51 mi) to the northern upstream extent of Lake Wallula (formed by McNary Dam), which begins above Richland. The Hanford Reach of the Columbia River was recently incorporated into the land area established as the Hanford Reach National Monument.

Flows in the Hanford Reach are directly affected by releases from Priest Rapids Dam; however, Priest Rapids operates as a run-of-the-river dam rather than a storage dam. Flows are controlled to generate power and promote salmon egg and embryo survival. Several drains and intakes are also present along the Hanford Reach, including irrigation outfalls from the Columbia Basin Irrigation Project, intakes at the Columbia Generating Station operated by Energy Northwest, and Hanford Site intakes for onsite water use.

The State of Washington has promulgated water quality standards for the Columbia River (*Washington Administrative Code* [WAC] 173-201A, "Water Quality Standards for Surface Waters of the State of Washington"). The Hanford Reach of the Columbia River has been designated as Class A (Excellent). This designation requires that the water be usable for substantially all needs, including drinking water, recreation, and wildlife. The DOE has conducted routine water-quality monitoring of the Columbia River since 1958.

2.2.6.2.1 Yakima River

The Yakima River, which follows a small length of the southwest boundary of the Hanford Site, has much lower flows than the Columbia River. The average flow, based on nearly 72 years of daily flow records, is ~100 m³/s (3,530 ft³/s), with an average monthly maximum of ~500 m³/s (17,550 ft³/s), and minimum of 4.7 m³/s (165 ft³/s). The Yakima River System drains surface runoff from approximately one-third of the Hanford Site. Contaminant plumes in groundwater

that originate from the Hanford Site do not reach the Yakima River and, because the elevation of the river surface is higher than the adjacent water table (based on well water-level measurements), groundwater is expected to flow from the Yakima River into the aquifer underlying the Site rather than from the aquifer into the river.

2.2.6.2.2 Springs and Streams

Springs are found on the slopes of Rattlesnake Hills (Figure 2-13) along the western edge of the Site. An alkaline spring is located at the east end of Umtanum Ridge. Rattlesnake and Snively Springs form small surface streams (Figure 2-13). Water is discharged from Rattlesnake Springs and flows in Dry Creek for ~2.6 km (1.6 mi) before disappearing into the ground. Cold Creek and its tributary, Dry Creek, are ephemeral streams within the Yakima River drainage system in the southwestern portion of the Site. These streams drain areas to the west of the Site and cross the southwestern part of the Site toward the Yakima River. When surface flow occurs, it infiltrates rapidly and disappears into the surface sediments in the western part of the Site. The quality of water in these springs and streams varies depending on the source; they are upgradient of Hanford waste and plumes of contaminated groundwater found on the Hanford Site.

2.2.6.2.3 Flooding

Columbia River flow is regulated by three upstream dams in Canada and by seven upstream dams in the United States. The Hanford Reach, ~80 km (50 mi) long, extends from Priest Rapids Dam to just north of the 300 Area. Flow through the Hanford Reach fluctuates significantly and is controlled at Priest Rapids Dam. The three dams with the largest reservoirs upstream from the Hanford Site are the Mica and Hugh Keenleyside Dams in Canada and the Grand Coulee Dam in the United States. The controlled flow of the Columbia River caused by these dams results in a lower flood hazard for high-probability floods (e.g., 100-year floods); however, dam-failure scenarios are significant potential contributors that result in high flood flows.

The probable maximum flood for the Columbia River downstream of Priest Rapids Dam has been calculated to be 40,000 m³/s (1.4 million ft³/s) (Figure 2-14) and is greater than the 500-year flood. This flood would inundate parts of the 100 Area adjacent to the Columbia River, but the central portion of the Hanford Site would remain unaffected. The U.S. Army Corps of Engineers has derived the Standard Project Flood with both regulated and unregulated peak discharges given for the Columbia River downstream of Priest Rapids Dam. The regulated Standard Project Flood for this part of the river is given as 15,200 m³/s (536,800 ft³/s) and the 100-year regulated flood is given as 12,400 m³/s (438,000 ft³/s). Impacts to the Hanford Site are negligible and would be less than the probable maximum flood.

Figure 2-14. Probable Maximum Flood Area on the Hanford Site as Determined by the Upper Limit of Precipitation and Maximum Runoff.

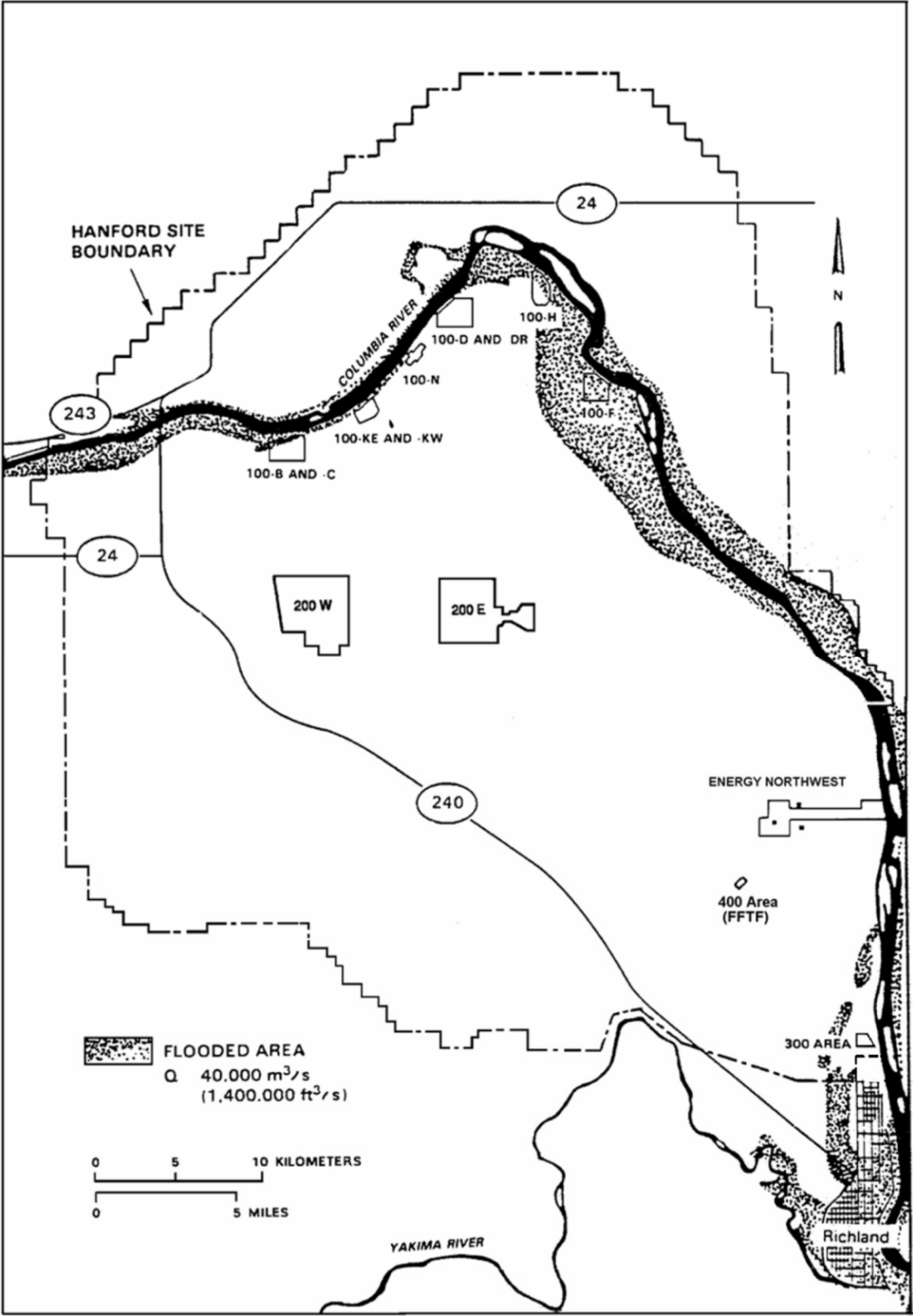

FFTF = Fast Flux Test Facility

The U.S. Army Corps of Engineers evaluated a number of scenarios on the effects of failures of Grand Coulee Dam, assuming flow conditions on the order of 11,325 m³/s (400,000 ft³/s). The discharge resulting from a 50% breach at the outfall of Grand Coulee Dam was determined to be 595,000 m³/s (21 million ft³/s). In addition to the areas inundated by the probable maximum flood, the remainder of the 100 Area, the 300 Area, and nearly all of Richland would be flooded as shown in Figure 2-14. No determinations were made for breaches greater than 50% of Grand Coulee Dam, for failures of dams upstream, or for associated failures downstream of Grand Coulee. The 50% breach scenario was believed to represent the largest realistically-conceivable flow resulting from either a natural or human-induced breach. It was also assumed that a scenario such as the 50% breach would occur only as the result of direct explosive detonation, and not because of a natural event such as an earthquake.

A flood scenario of a 50% breach of Grand Coulee Dam results in a flood level of ~143.3 m (470 ft) above mean sea level at Columbia River mile 365; this low point is the closest flood route to the 200 Areas Plateau. River mile 365 is ~45.7 m (150 ft) below the ground surface of the lowest elevation tank farm. The 50% breach of the Grand Coulee Dam would not impact the 200 East and 200 West areas or the land within the 600 Area (i.e., between the 200 East and 200 West areas) occupied by tank farm facilities. Therefore, this scenario bounds all other Columbia River flood scenarios.

The Yakima River is ~19.3 km (12 mi) south of and greater than 61 m (200 ft) in elevation below the 200 East and 200 West areas. The Yakima River is not a flood hazard for the tank farm facilities. During 1980, a flood risk analysis of Cold Creek was conducted as part of the characterization of a basaltic geologic repository for HLW. In lieu of 100- and 500-year floodplain studies, a probable maximum flood evaluation was performed based on a large rainfall or combined rainfall/snowmelt event in the Cold Creek and Dry Creek watershed (Figure 2-15). The probable maximum flood discharge rate for the lower Cold Creek Valley was 2,265 m³/s (80,000 ft³/s) compared to 564 m³/s (19,900 ft³/s) for the 100-year flood. Modeling indicated that State Route 240, along the Hanford Site's southwestern and western areas, would not be usable. Based on this information, flooding of the IDF would not be a credible scenario.

2.2.7 Groundwater

This section describes the relevant characteristics of the groundwater hydrology, which has been studied and monitored in detail because of the waste disposal operations at the site. The hydrology characteristics of the Hanford Site are important to the definition of potential pathways for the IDF contaminants to the public and the estimation of the magnitudes of the environmental impacts. Evaluating this pathway requires information about the types of aquifers, depth to the water table, and regional flow paths toward surface water discharge points.

The discussion focuses on the geohydrology of the 200 Areas but also includes information on the Hanford Site in general, highlighting those aspects that were important to the modeling of the post-closure performance.

Figure 2-15. Probable Maximum Flood Area in Cold Creek Area, Hanford Site Delineated Using the U.S. Army Corps of Engineers' HEC-2 Water Surface Profiles Model.

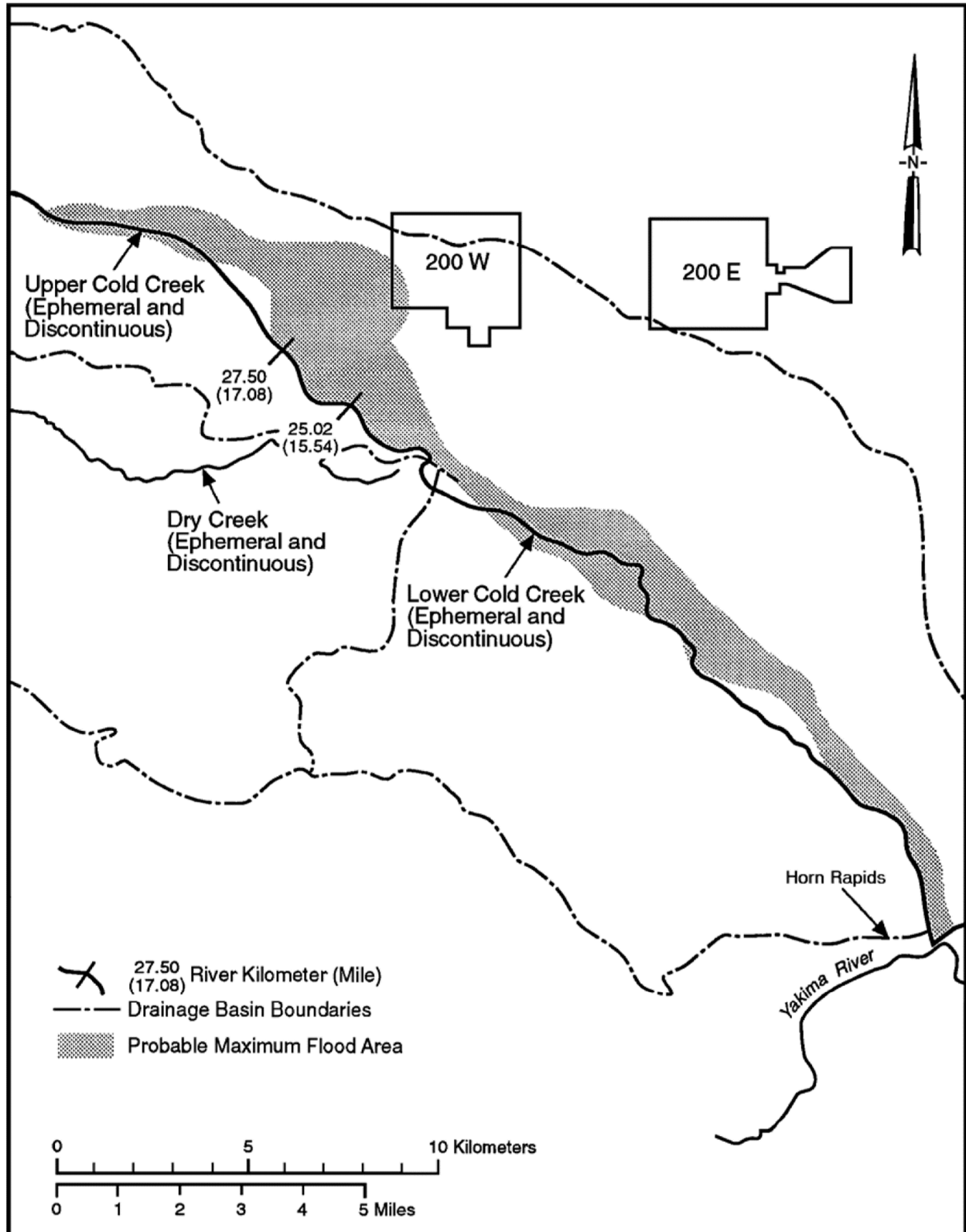

Groundwater beneath the Hanford Site is found in both an upper unconfined aquifer system and deeper basalt-confined aquifers. The unconfined aquifer system is also referred to as the suprabasalt aquifer system because it is within the sediments that overlie the basalt bedrock. Portions of the suprabasalt aquifer system are locally confined. However, because the entire suprabasalt aquifer system is interconnected on a site-wide scale, it is referred to in this report as the Hanford unconfined aquifer system.

2.2.7.1 Existing Groundwater Contamination

Note: Information concerning existing groundwater contamination is provided for additional background, and is not within the scope of this Draft WIR Evaluation.

When the Hanford Site was operating, spent fuel reprocessing, isotope recovery operations, and associated waste management activities occurred within the 200 East and 200 West Areas located in the central portion of the Site. Waste disposal within the 200 Areas began with startup of plutonium-separation operations in late 1944. Three separations processes were used. The earliest was the bismuth-phosphate process, which was used between 1944 and 1956 at T Plant in the 200 West Area (200-ZP groundwater interest area), and between 1945 and 1952 at B Plant in the 200 East Area (200-BP). The REDOX process was used between 1952 and 1967 at the REDOX Plant in the 200 West Area (200-UP). Finally, the PUREX process was used from 1956 to 1972, and again from 1983 to 1989 at the PUREX Plant in the 200 East Area (200-PO).

Beginning in 1949, the product from the separations plants was further processed at the Plutonium Finishing Plant (PFP) (200-ZP), which operated until 1989. Other chemical processes performed in the 200 Areas included uranium recovery, using the tributyl phosphate process at U Plant (200-UP) between 1952 and 1957, and radionuclide recovery by various methods at B Plant (200-BP) between 1963 and 1983. Each chemical processing facility generated multiple waste streams and used multiple waste sites for waste management and disposal.

Additionally, the 200 Areas contain seven SST WMAs: A-AX, B-BX-BY, and C within the 200 East Area and S-SX, T, TX-TY, and U within the 200 West Area. Unplanned releases (UPRs) (e.g., tank liner leaks or releases from cascade lines or spare ports) have contaminated the vadose zone and some of this contamination has migrated downward to the groundwater. Migration through the vadose zone may have been facilitated in the past by additions of water from various sources, most notably nearby wastewater ditches and cribs, water supply pipeline leaks, and rainfall/snowmelt runoff events. Nitrate, chromium and ⁹⁹Tc from many of the tank farms, as well as uranium specifically from WMA B-BX-BY, form substantial groundwater plumes. These plumes generally are expanding in areal extent and exhibit increasing constituent concentrations indicating that contaminants continue to enter the groundwater from the vadose zone.

The intentional disposal of waste streams to ponds, ditches, and cribs, combined with the UPRs from the WMAs, has resulted in a complex mixture of soil and groundwater contamination that complicates the process of interpreting specific contaminant sources for specific plumes.

Groundwater monitoring is/has been performed on a regular basis to evaluate levels of contamination, movement of groundwater plumes, and changes to the unconfined/confined

aquifers. Each year an annual groundwater monitoring report is issued. This annual report provides monitoring results required by DOE; for RCRA treatment, storage and disposal units; and for *Comprehensive Environmental Response, Compensation, and Liability Act* (CERCLA) groundwater operable units (OUs).

The annual report divides the Central Plateau into four geographical groundwater interest areas (200-BP-5, 200-PO-1, 200-UP-1, and 200-ZP-1). These groundwater interest areas encompass groundwater contamination from the 200 East and 200 West Areas and regions into which this contamination has migrated beyond the Central Plateau (Figure 2-16). The IDF falls within the 200-PO-1 OU.

Groundwater contaminant plumes of ^3H , nitrate, and ^{129}I formed when the waste discharged to ponds and cribs reached the aquifer. These contaminants form regional plumes originating on the Central Plateau (Figure 2-16). The ^3H and nitrate plumes have decreased in area over the years due to radioactive decay (^3H only) and dispersion; the area of ^{129}I has remained stable. A large carbon tetrachloride plume originated in the 200 West Area. Other groundwater contaminants in the Central Plateau include ^{99}Tc , uranium, ^{90}Sr , trichloroethene, cyanide, and other dangerous waste constituents.

The unconfined aquifer within the 200 East Area boundary is the primary aquifer impacted by past waste disposal operations and is associated with the suprabasalt sediment of the Ringold Formation, CCU, and Hanford formation. The greatest concentration/activity of nitrate, ^{99}Tc , and uranium is in the 200-BP-5 OU area within the northwest portion of the 200 East Area, also referred to as the B Complex (e.g., 241-B-BX-BY single-shell underground storage tank area “Waste Management Area B-BX-BY” and adjacent liquid waste sites) (Figure 2-17). These plumes extend both to the northwest and southeast within an ancestral Columbia River paleochannel that incised semi-consolidated gravels and cohesive fluvial-lacustrine Ringold deposits.

The IDF resides within the 200-PO groundwater operable unit at Hanford. Monitoring of the wells near the IDF have been undertaken. Wells selected for monitoring are shown in Figure 2-18. Monitoring for the 200-PO interest area is implemented through the CERCLA sampling and analysis plan. The sampling plan describes sampling of two upgradient wells (299-E18-1 and 299-E24-24) and five downgradient wells (299-E17-22, 299-E17-23, 299-E17-25, 299-E17-26, and 299-E24-21) semiannually for gross alpha, gross beta, ^{129}I , and ^{99}Tc . In addition, the IDF is currently monitored as part of a detection monitoring program. Since the IDF is not yet operational, the current monitoring objective is to collect baseline groundwater information. The results of that monitoring are summarized below.

Based on the current southeasterly groundwater flow direction, the monitoring network configuration includes one upgradient well (299-E24-24), two cross-gradient wells (299-E18-1 and 299-E24-21), and four downgradient wells (299-E17-22, 299-E17-23, 299-E17-25, and 299-E17-26) (Figure 2-18). Gross alpha was detected in wells 299-E18-1, 299-E17-22, 299-E17-23, 299-E17-26, and 299-E24-21 at concentrations ranging from 2.62 pCi/L at 299-E18-1 to 10.7 pCi/L at 299-E24-21. Gross alpha concentrations intermittently spiked in wells 299-E24-21 (10.7 pCi/L) and 299-E17-22 (11.1 pCi/L) during 2014 and 2015. Gross beta

was detected in each of the monitored wells at concentrations ranging from 5.56 pCi/L (299-E18-1) to 48 pCi/L (299-E24-21). The gross beta concentration correlates with changes in ⁹⁹Tc concentration. Iodine-129 concentrations were nondetectable in all wells except 299-E17-22 (0.56 pCi/L). Technetium-99 concentrations ranged from nondetectable (299-E18-1) to 51.5 pCi/L (299-E24-21).

Figure 2-16. Central Plateau Groundwater Contaminant Plumes in 2015 and Remediation.

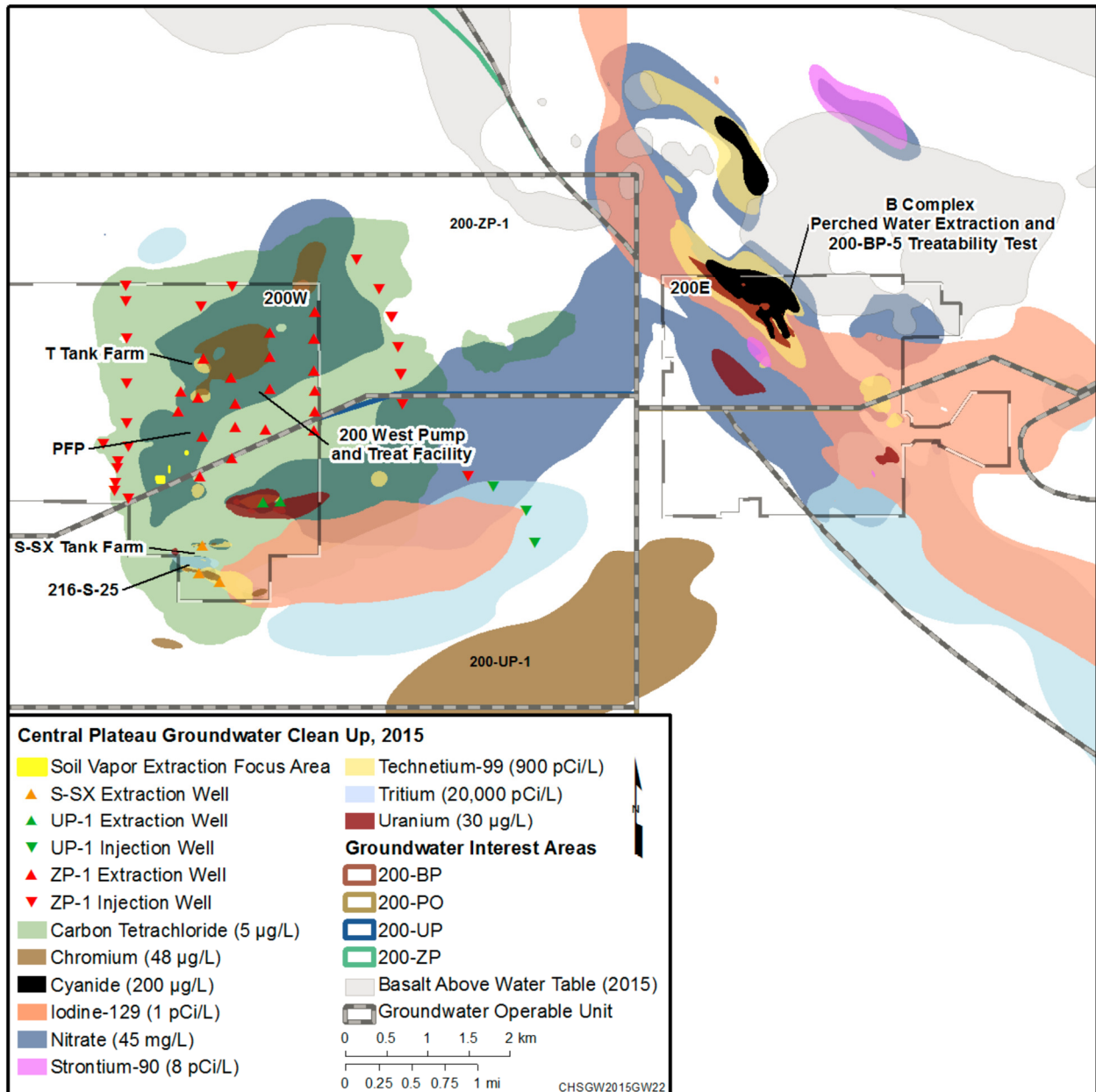

PFP = Plutonium Finishing Plant

Figure 2-17. 200 East Area Groundwater Contaminant Plumes in 2015.

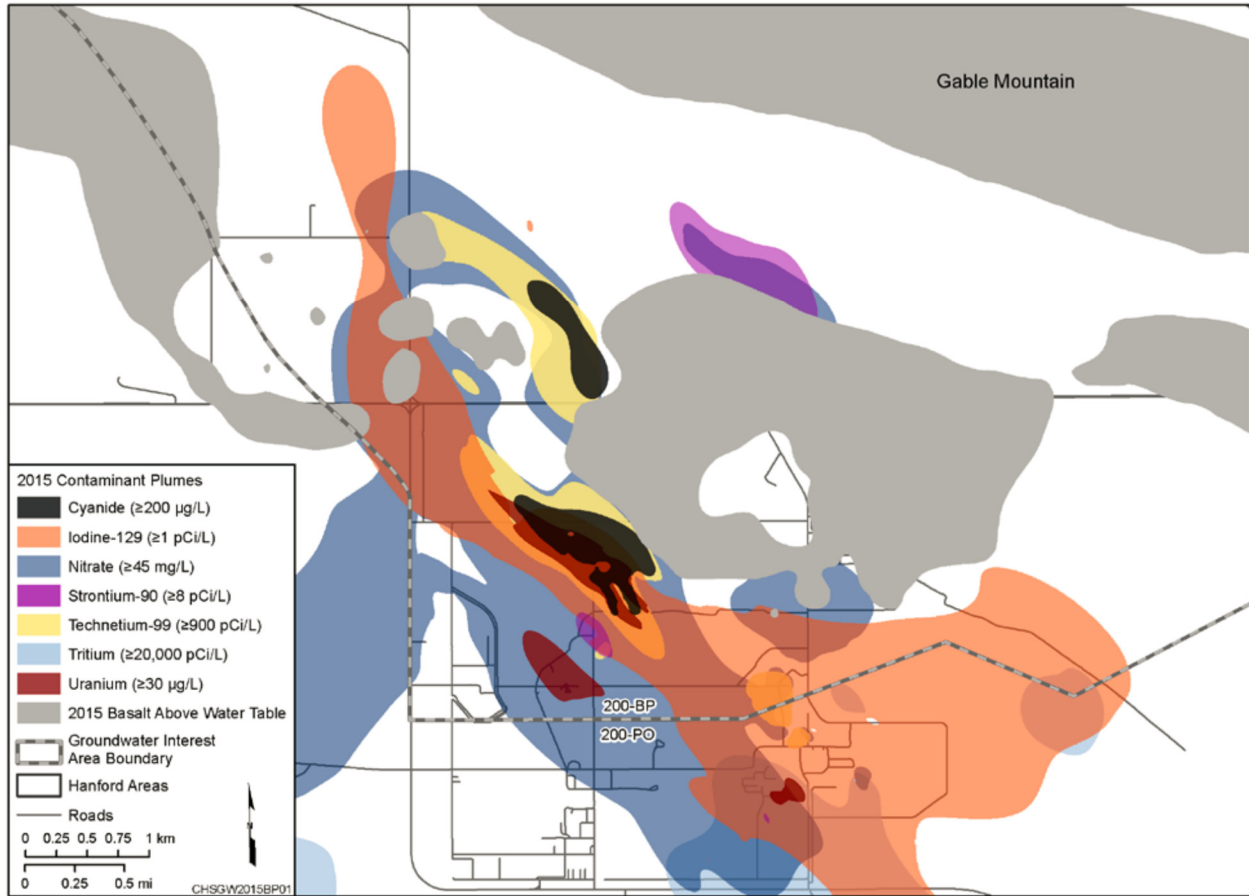

Beginning in 2008, data collection efforts were undertaken to improve the accuracy of the water-level measurements so that the groundwater flow direction beneath the PUREX Cribs and the nearby IDF could be evaluated in greater detail. Trend surface analysis of water-level measurements from June 2008 through March 2011 indicated an average hydraulic gradient magnitude of 2.2×10^{-5} ($\pm 0.3 \times 10^{-5}$) m/m with an east-northeast direction (64 [± 12] degrees azimuth). Measurements between June 2011 and December 2012 indicated an average hydraulic gradient magnitude of 2.4×10^{-5} ($\pm 0.2 \times 10^{-5}$) m/m with an eastern flow direction (95 [± 5] degrees azimuth). The low-gradient network water-level data for 2013 and 2014 indicated a southeast flow direction near the IDF. The low-gradient network water-level data for 2015 indicates an east-southeast flow direction with an average gradient of 3.8×10^{-6} m/m. The groundwater flow velocity is estimated to range from 0.002 to 0.003 m/d (0.007 to 0.01 ft/d). This estimate assumes that the hydraulic conductivity of the unconfined aquifer is between 68 to 75 m/day, the effective porosity is 0.1 and the gradient is 3.8×10^{-6} m/m. The hydraulic conductivity estimate is based on slug tests conducted in two boreholes near the IDF. This test method has been noted to provide only minimum estimates of the hydraulic conductivity in a very small volume of the aquifer around the borehole and these estimates are not representative of larger-scale hydraulic conductivity that is more appropriate for defining flow rates in the saturated Hanford gravels near the IDF. Below is a summary description for existing

groundwater contamination in the 200-PO groundwater interest area for the IDF for the following contaminants:

- Tritium
- ^{129}I
- Nitrate
- ^{99}Tc
- Uranium.

Tritium

Tritium contamination in groundwater is found at a concentration greater than the 20,000 pCi/L *Safe Drinking Water Act of 1974* (SDWA) maximum contaminant level (MCL) in a large plume within 200-PO from the 200 East Area to the Columbia River. The highest current and historical concentrations have been detected near the PUREX Cribs and Trenches, which were the major sources of this contaminant. The ^3H plume continues to be present in groundwater downgradient of the source with a portion of the plume discharging into the Columbia River to the east (Figure 2-16). Decreasing concentrations and attenuation of the plume in the area is due to dispersion and radioactive decay of ^3H , but concentrations near the PUREX Cribs and Trenches remain up to 25 times the SDWA MCL of 20,000 pCi/L and have been relatively stable since 2000.

Iodine-129

Iodine-129 concentrations detected in 200 Area wells in 2015 ranged from nondetectable to 10.1 pCi/L. The National Primary Drinking Water Standard for Iodine-129, which is a beta particle emitter, is 4 millirem/year (40 CFR 141.66, “Maximum contaminant levels for radionuclides”). U.S. EPA reports that an ^{129}I concentration equal to 1.0 pCi/L yields 4 mrem/yr to the total body or to any critical organ (EPA 815-R-02-001, *Radionuclides in Drinking Water: A Small Entity Compliance Guide*). The DOE-derived concentration that yields an annual effective dose of 4 mrem is 13.2 pCi/L (derived from DOE-STD-1196-2011, *DOE Standard, Derived Concentration Technical Standard*, Table 5). The highest concentrations in 2015 were detected near the PUREX Cribs and Trenches, 216-A-29 Ditch, B Pond, and WMA A-AX. In 2015, the highest concentrations of ^{129}I were detected in wells 699-43-45 (10.1 pCi/L), 299-E17-19 (7.57 pCi/L), 299-E17-14 (7.49 pCi/L), and 299-E26-4 (5.94 pCi/L). The highest concentrations of ^{129}I detected in 2015 sampling conducted in the far-field area occurred at wells 699-32-22A (5.46 pCi/L) and 699-41-23 (3.98 pCi/L).

Figure 2-18. 200-PO Well Locations

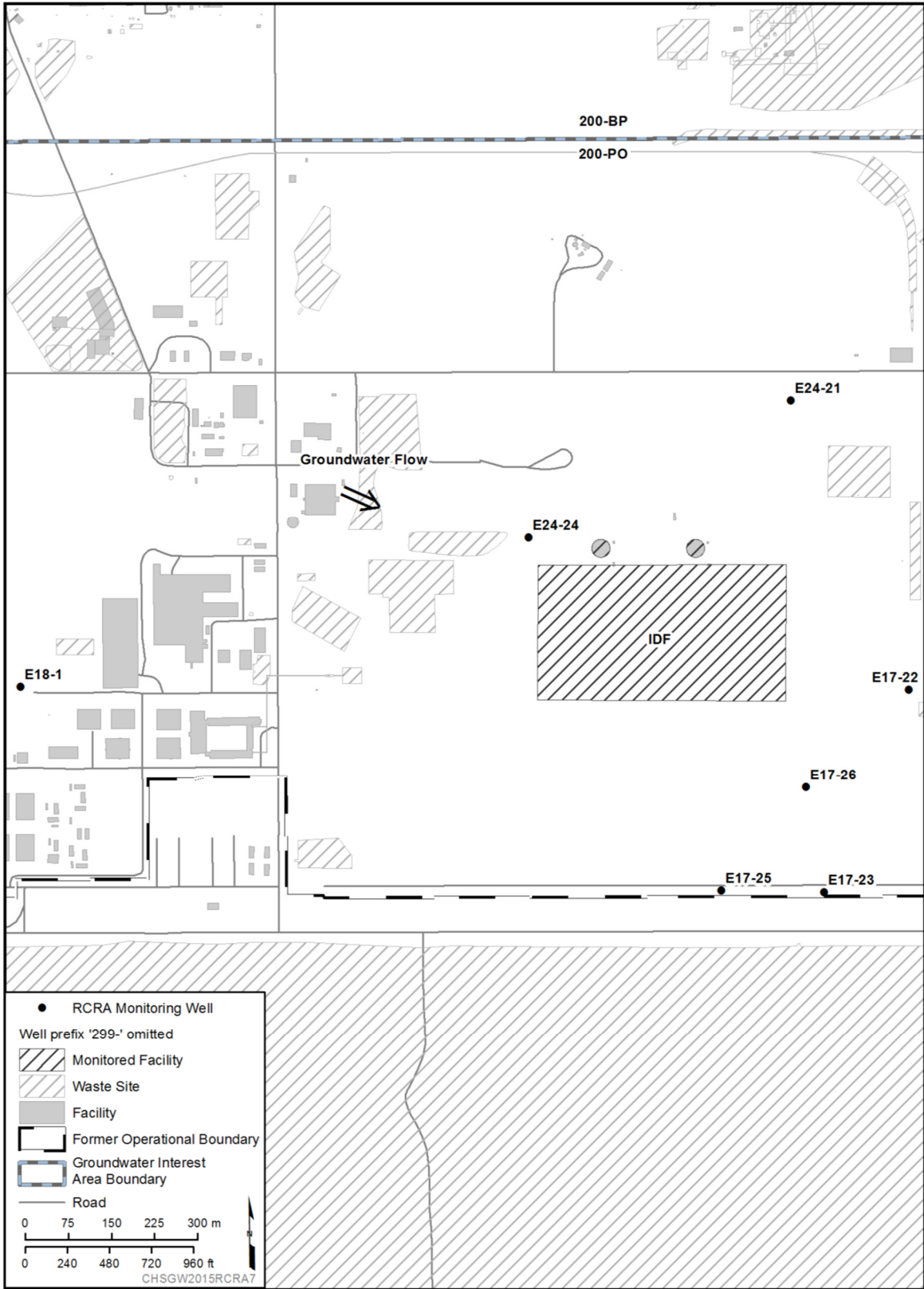

RCRA = Resource Conservation and Recovery Act of 1976

Nitrate

Nitrate has historically been detected in an area of 200-PO near the PUREX Cribs and Trenches. The National Primary Drinking Water Standard for nitrate is 10 mg Nitrogen / L (40 CFR 141.23, “Inorganic chemical sampling and analytical requirements”), which is equivalent to 44.3 mg NO₃ /L. Based on samples collected during 2015, the highest nitrate concentrations in 200-PO were 139 mg/L at well 299-E17-19 (located downgradient of the 216 A 10 Crib) and 131 mg/L from well 299-E17-14 (located downgradient of the 216-A-36B Crib). Some of the wells near the PUREX Cribs, including 299-E24-16, 299-E17-19, 299-E17-1, 299-E17-18 (near the 216-A-10 and 216-A-36B Cribs), 299-E25-17, 299-E25-18, and 299-E25-20 (near the 216-A-37-1 Crib), have exhibited increasing nitrate concentrations since early 2000. Changes in the nitrate plume configuration and concentration trending at individual wells indicate that nitrate is slowly migrating to the southeast, consistent with the flow direction calculated from trend surface analyses of the low-gradient network water-level measurements. The maximum nitrate concentration detected near the IDF in 2015 was 61.5 mg/L in well 299-E17-22. The wells that monitor the IDF site are within the regional 200 East Area nitrate plume.

Technetium-99

Technetium-99 has historically been detected in a small area in the 200-PO near-field region around WMA A-AX. This plume appears to have sources both in WMA C (in 200-BP) and in WMA A-AX (in 200-PO). WMA A-AX is hydraulically downgradient of WMA C. Concentrations greater than the 900 pCi/L SDWA MCL have been detected in groundwater near WMA A-AX since 2003. The interpolated 2015 boundary of the 900 pCi/L concentration extends from WMA C to the southeast toward the upgradient portion of WMA A-AX, as defined by wells 299-E24-22 (2,570 pCi/L) and 299-E24-33 (1,128 pCi/L).

Uranium

Uranium has been identified historically as a relatively small plume near the PUREX Cribs and Trenches in the near-field area and adjacent to the 618-10 Burial Ground. In 2015, concentrations of uranium above the 30 µg/L SDWA MCL were detected in two wells: well 299-E25-36, at an average concentration of 42.4 µg/L, compared to 57.1 µg/L in 2014; and well 299-E24-23 at a concentration of 35.3 µg/L, compared to 39.5 µg/L in 2014. Well 299-E24-23 is located adjacent to the 216-A-4 Crib south of PUREX. Uranium remains somewhat mobile in groundwater at 200-PO, and the concentration changes observed are consistent with continued slow migration of uranium away from source areas.

2.3 RADIOACTIVITY IN THE UNDERGROUND WASTE STORAGE TANKS

The Hanford underground storage tanks (SSTs and DSTs) received radioactive waste from sources other than the four facilities used to reprocess SNF to recover uranium and plutonium (WHC-MR-0132, *A History of the 200 Area Tank Farms*), including:

- U Plant, which recovered uranium from BPP metal wastes from 1952 through 1957

- N Reactor
- Various research activities and targeted isotopes separation campaigns
- 300 Area facilities
- Various facility decommissioning activities.

Hanford maintains the tank waste radionuclide inventory in a database known as the Best-Basis Inventory (BBI). This inventory includes 46 radionuclides. Inventories are provided for each tank using waste sample data and process history modeling and are updated quarterly. Table 2-3 shows the total radionuclide inventory of the tank farms using the BBI estimates available in July 2017.²³

The BBI was developed to use the best available information to estimate inventories of chemicals and radionuclides of the underground waste tank contents (RPP-7625, *Guidelines for Updating Best-Basis Inventory*, Appendix A). It establishes the inventory of the underground waste storage tanks at Hanford by using sample data, process knowledge, surveillance data, and waste stream composition information from the Hanford Defined Waste (HDW) computer model (LA-UR-96-3860, *Hanford Tank Chemical and Radionuclide Inventories: HDW Model Rev. 4*). The BBI is documented in the Tank Waste Information Network System maintained by the Pacific Northwest National Laboratory (PNNL) and can be found on this publicly-available webpage, <https://twins.labworks.org/twinsdata/Forms/About.aspx>.

The inventory estimates in Table 2-3 for ¹³⁷Cs and ⁹⁰Sr would have been much higher had not significant amounts of these radionuclides been selectively removed previously. From 1967 to 1985, these radionuclides were recovered from tank waste to reduce curie load to make room for new tank waste. When produced, these capsules contained about 130 MCi of radioactive cesium and strontium. These are kept in water-filled pools in the Waste Encapsulation and Storage Facility adjoining B Plant in the 200 Area (PNNL-13605), and will be moved to dry storage. As of June 2017, DOE estimates the capsules had decayed to 46 MCi (83 FR 23270, “Amended Record of Decision for the Management of Cesium and Strontium Capsules at the Hanford Site, Richland, Washington”).²⁴

²³ Note that this information uses the BBI estimate current in July 2017 with a decay date of July 1, 2017. For ILAW, the IDF PA uses the BBI estimate current in November 2014 with a decay date of January 1, 2008.

²⁴ These cesium and strontium capsules are outside the scope of this Draft WIR Evaluation.

Table 2-3. Estimated Total Radioactivity in 177 Underground Waste Tanks (Ci).

| Nuclides | Supernate | Saltcake | Sludge | Total |
|-------------------------------|-----------------|-----------------|-----------------|-----------------|
| ³ H | 2.35E+02 | 8.10E+02 | 4.38E+02 | 1.48E+03 |
| ¹⁴ C | 8.32E+01 | 3.81E+02 | 4.10E+01 | 5.05E+02 |
| ⁶⁰ Co | 9.99E+01 | 3.72E+02 | 6.07E+02 | 1.08E+03 |
| ⁵⁹ Ni | 1.17E+02 | 1.10E+03 | 2.53E+02 | 1.47E+03 |
| ⁶³ Ni | 7.58E+03 | 9.44E+04 | 2.18E+04 | 1.24E+05 |
| ⁹⁰ Sr | 4.07E+05 | 2.42E+06 | 3.45E+07 | 3.74E+07 |
| ⁹⁴ Nb ^a | not available | not available | not available | not available |
| ⁹⁹ Tc | 1.07E+04 | 1.31E+04 | 1.84E+03 | 2.56E+04 |
| ¹²⁶ Sn | 1.68E+02 | 1.81E+02 | 2.78E+01 | 3.77E+02 |
| ¹²⁹ I | 1.31E+01 | 1.29E+01 | 3.22E+00 | 2.93E+01 |
| ¹³⁷ Cs | 1.72E+07 | 1.09E+07 | 3.39E+06 | 3.15E+07 |
| ²²⁹ Th | 8.55E-02 | 6.68E-03 | 1.17E+00 | 1.27E+00 |
| ²³³ U | 1.26E+00 | 1.43E+02 | 4.43E+02 | 5.87E+02 |
| ²³⁴ U | 6.83E-01 | 3.37E+01 | 1.91E+02 | 2.26E+02 |
| ²³⁸ U | 5.48E-01 | 3.03E+01 | 1.75E+02 | 2.06E+02 |
| ²³⁷ Np | 4.82E+00 | 5.47E+01 | 4.91E+01 | 1.09E+02 |
| ²³⁸ Pu | 5.18E+01 | 3.57E+02 | 1.90E+03 | 2.31E+03 |
| ²³⁹ Pu | 2.13E+02 | 1.06E+04 | 3.29E+04 | 4.37E+04 |
| ²⁴⁰ Pu | 5.32E+01 | 2.27E+03 | 7.27E+03 | 9.58E+03 |
| ²⁴¹ Pu | 4.75E+02 | 9.32E+03 | 3.94E+04 | 4.92E+04 |
| ²⁴² Pu | 4.57E-02 | 1.55E-01 | 6.56E-01 | 8.57E-01 |
| ²⁴¹ Am | 2.27E+03 | 2.09E+04 | 1.11E+05 | 1.34E+05 |
| ²⁴³ Am | 1.49E+00 | 1.20E+01 | 5.23E+01 | 6.57E+01 |
| ²⁴² Cm | 9.48E+00 | 1.87E+01 | 9.04E+01 | 1.19E+02 |
| ²⁴³ Cm | 2.32E+00 | 5.12E-01 | 8.55E+00 | 1.14E+01 |
| ²⁴⁴ Cm | 4.51E+01 | 9.80E+00 | 1.63E+02 | 2.18E+02 |
| Others ^b | 1.70E+07 | 1.38E+07 | 3.94E+07 | 7.02E+07 |
| Totals | 3.47E+07 | 2.72E+07 | 7.76E+07 | 1.39E+08 |

Source: From BBI available in Tank Waste Information Network System as of July 2017 with radionuclides decayed to July 1, 2017, with values rounded to three significant figures.

^a The BBI does not include tank inventory information for ⁹⁴Nb as a standard analyte.

^b ¹³⁷Cs and ⁹⁰Sr equilibrium decay daughter products (^{137m}Ba and ⁹⁰Y, respectively) are included in the "Others" radionuclides, even though they are not included in 10 CFR 61.55, "Waste Classification," Table 2 because radiological impacts associated with the equilibrium daughters were considered when the U.S. Nuclear Regulatory Commission determined the parent concentration limits.

2.4 TANK WASTE RETRIEVAL, TREATMENT, AND DISPOSAL PLAN

The DOE Office of River Protection (ORP) is responsible for retrieval, treatment, and closure of the tanks in the 200 East and 200 West Areas on the Hanford Site as shown in Figure 2-19.

Figure 2-19. Hanford Site Map Showing Different Areas.

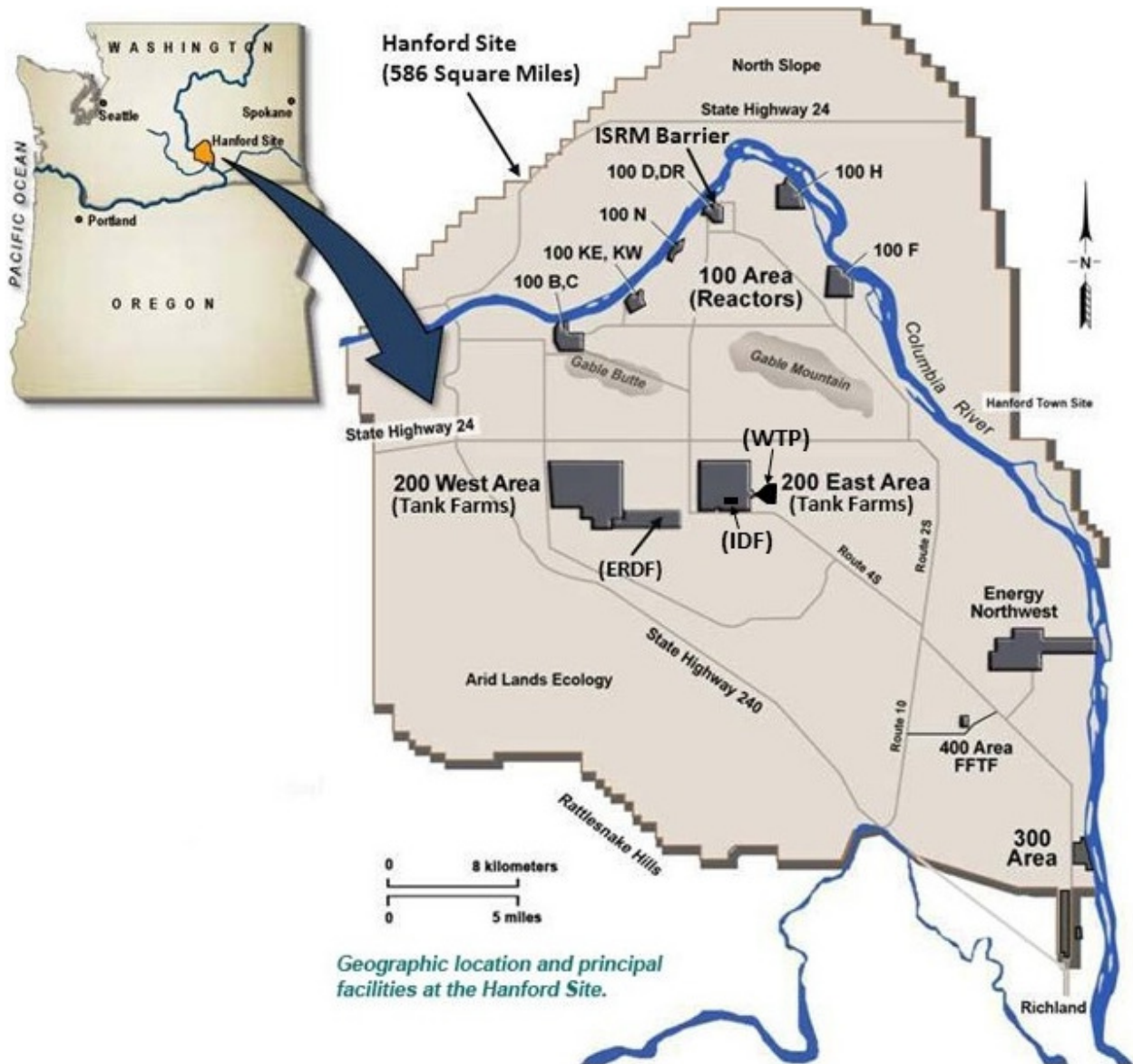

ERDF = Environmental Restoration Disposal Facility

FFTF = Fast Flux Test Facility

IDF = Integrated Disposal Facility

ISRSM = In Situ Redox Manipulation

WTP = Hanford Tank Waste Treatment and Immobilization Plant

ORP-11242, *River Protection Project System Plan*, (presently revision 8) describes the processes for retrieving and treating the tank waste and closing the 177 underground waste tanks in place. This plan describes, as a baseline case, a program for achieving the mission of the River Protection Project. The baseline case provides a technical basis for project planning, including

budgets and schedules. The ORP updates the *River Protection Project System Plan* from time to time so it can serve as a living document that reflects the latest expectations for completion of tank waste retrieval, treatment, and disposal.

The *River Protection Project System Plan* outlines the strategy for achieving the project mission as follows:

- Retrieving the waste from SSTs to DSTs and delivering the waste to the WTP
- Constructing and operating the WTP, which includes the Pretreatment Facility, LAW Vitrification Facility, HLW Vitrification Facility, Analytical Laboratory, and the Balance of Facilities
- DFLAW to the LAW Vitrification Facility as part of a phased startup
- Developing and deploying supplemental treatment capability to safely treat the remainder of the LAW not vitrified by the LAW Vitrification Facility²⁵
- Developing and deploying supplemental capability for separating solids and soluble cesium as needed
- Developing and deploying treatment and packaging capability for potential transuranic tank waste, followed by interim storage at the Central Waste Complex pending determination of the final disposal pathway
- Deploying interim storage capacity for the vitrified high-level waste pending determination of the final disposal pathway
- Disposing of packaged VLAW onsite at the Integrated Disposal Facility
- Closing the SST and DST farms, ancillary facilities, and associated waste management and treatment facilities
- Sequencing the River Protection Project mission around resolution of technical and programmatic uncertainties
- Upgrading the tank farms to provide a steady, well-balanced feed to the WTP
- Investigating trade-offs of the required amount and type of supplemental treatment and pretreatment and the amount of vitrified high-level waste and VLAW.

²⁵ As stated in DOE's Record of Decision for the *Tank Closure and Waste Management Environmental Impact Statement*, DOE does not have a preferred alternative regarding supplemental treatment for LAW; DOE believes it is beneficial to study further the potential cost, safety, and environmental performance of supplemental treatment technologies. See 78 FR 75913 at 75916.

2.5 HANFORD TANK WASTE TREATMENT AND IMMOBILIZATION PLANT

The process descriptions of the WTP and its facilities are based primarily on information from Appendix E of the TC&WM EIS (DOE/EIS-0391), and DOE/EIS-0391-SA-02, *Supplement Analysis of the Final Tank Closure and Waste Management Environmental Impact Statement for the Hanford Site, Richland, Washington*, unless otherwise noted.

2.5.1 Background

The purpose of the WTP is to treat waste retrieved from underground tanks to prepare it for permanent disposal. The WTP is located at the center of the Hanford Site adjacent to the 200 East Area near the underground waste tanks. The WTP site occupies 65 acres and includes four major nuclear facilities: Pretreatment Facility (PTF), HLW Vitrification Facility, LAW Vitrification Facility, and Analytical Laboratory (LAB). There are also 22 support facilities collectively referred to as the Balance of Facilities.

Construction of WTP began in 2002, with completion initially scheduled for 2011. However, technical challenges and other issues related to design and construction of the complex plant have led to delays. Due to these technical issues with the PTF and HLW Vitrification Facilities, only the LAW Vitrification Facility, LAB, and Balance of Facilities are near completion.

To begin treating waste as soon as practicable, DOE has developed a sequenced approach that will treat LAW first, starting no later than 2023. The sequenced approach, which DOE refers to as DFLAW, will pretreat and send the LAW waste stream from the tank farms directly to the LAW Vitrification Facility for immobilization. Figure 2-20 shows the Hanford Site facilities that are part of the DFLAW approach.

2.5.1.1 Direct Feed Low-Activity Waste Summary

The DFLAW approach will be implemented in two phases. Both phases begin with in-tank settling and separation (removal by decanting) of the supernate (including dissolved saltcake and interstitial liquids) from the wastes in the applicable tanks.²⁶ Phase 1 of DFLAW involves processing tank supernate through the TSCR unit. Phase 2 of DFLAW pretreatment will use either an additional TSCR unit or a filtration and cesium removal facility. An estimated total volume of 23.5M gallons of the LAW generated using the DFLAW approach is planned to be immobilized in glass by vitrification. The total number of VLAW containers produced during DFLAW will be approximately 13,500.

2.5.1.2 Direct-Feed Low-Activity Waste Facilities

This subsection was adapted from DOE/EIS-0391-SA-02, unless otherwise noted. To accomplish DFLAW, DOE plans to complete construction of the following facilities: the Effluent Management Facility (EMF), a cesium removal system (initially a TSCR unit followed by either an additional TSCR unit or construction and use of a filtration and cesium removal facility), necessary transfer lines, and an IX Column Storage Pad. The facilities will all be

²⁶ This is the primary method to separate out (remove) the long-lived insoluble radionuclides for the DFLAW approach.

located in the 200 East Area, which over the past several decades has been a heavily-impacted and highly-disturbed industrial area.

Figure 2-20. Hanford Site Components in the Direct-Feed Low-Activity Waste Approach.

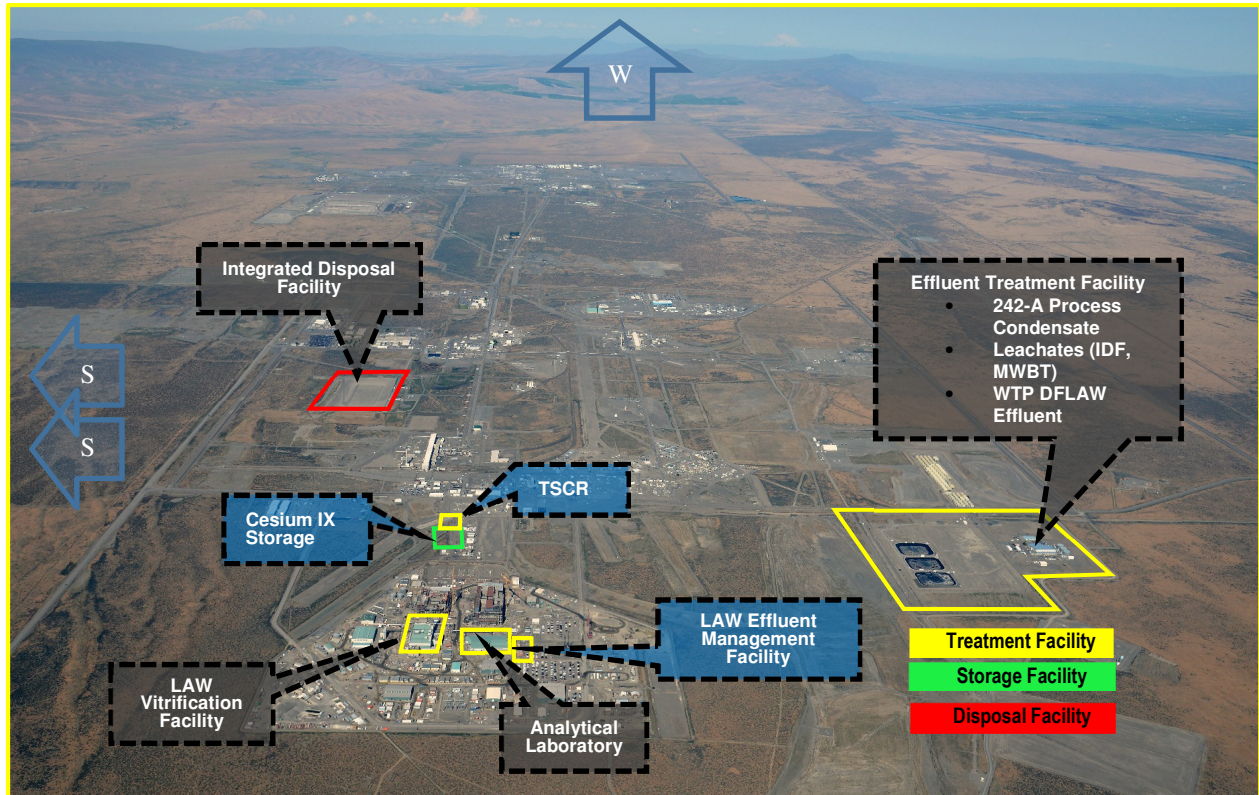

- | | |
|--|---|
| DFLAW = Direct-Feed Low-Activity Waste | MWBT = mixed waste burial trench |
| IDF = Integrated Disposal Facility | TSCR = Tank-Side Cesium Removal |
| IX = ion exchange | WTP = Hanford Tank Waste Treatment and Immobilization Plant |
| LAW = Low-Activity Waste | |

Both Phase 1 and Phase 2 of DFLAW pretreatment will filter and pretreat the supernate (including dissolved saltcake and interstitial liquids). Although the supernate is expected to contain very little solid material, DFLAW pretreatment will include filtration²⁷ (to remove solids) and IX columns (primarily to remove cesium). DOE plans to sample and control the feed to the cesium removal system to prevent the introduction of waste streams that will not meet the LAW Vitrification Facility waste acceptance criteria. Figure 2-20 shows the location of the DFLAW facilities.

The pretreated waste will be transferred to the LAW Vitrification Facility through a new transfer line, which will tie into an existing line. The LAW Vitrification Facility will immobilize the waste by combining it with glass formers that will be turned into molten glass and then poured

²⁷ The filter will remove solid particles which may contain insoluble key radionuclides. The filter will also remove suspended solids that potentially contain fissile particles, to meet the LAW Vitrification Facility waste acceptance criteria, which is premised on Design Safety Analysis requirements to prevent criticality.

into steel containers, where it will cool and solidify. The containers will be transported by truck to the IDF.

2.5.1.3 Direct-Feed Low-Activity Waste Feed Delivery and Feed Preparation

The campaigns planned for DFLAW operations are nominally 1 Mgal²⁸ of supernate per campaign, that originate from:

- a) supernate waste currently in DSTs,
- b) supernate derived from recently-retrieved SST saltcake,
- c) supernate derived from TSCR process returns, and
- d) supernate derived from remediated Waste Group A DSTs.²⁹

For SSTs covered by the DFLAW approach, the tank waste has previously settled and the supernate has been removed into DSTs. The SST saltcake will be re-dissolved with water or supernate into a liquid fraction and will include interstitial liquid trapped within the saltcake crystalline matrix. The re-dissolved saltcake and interstitial liquid from the applicable SSTs for each DFLAW campaign will be transferred to the DST system.

Once in the DST system, waste will be decanted (separated and removed) from the undissolved solids (saltcake and sludge layers). Decanting is the process of pumping only the liquid fraction from the tank without disturbing the solids. The bulk of the key radionuclides such as strontium, uranium, and the transuranic constituents (neptunium, plutonium isotopes, americium, and curium) are contained in the water-insoluble fraction (i.e., solids) of the tank wastes. The bulk of the ¹³⁷Cs, ⁹⁹Tc, ¹²⁹I, ¹⁴C, and ³H is contained in the soluble fraction of the tank waste. Additional settling/decanting will occur during campaign assembly and qualification process. The settle/decant separations process ensures that the majority of the longer-lived, key radionuclides present in the solids are separated from, and not included in, the LAW feed to TSCR.

As shown in Figure 2-21, four DSTs in 241-AP Tank Farm (AP Farm) will be dedicated to TSCR and the DFLAW system. These DSTs will be used to prepare, stage, characterize, and feed pretreated tank supernate to the LAW Vitrification Facility in compliance with 24590-WTP-ICD-MG-01-030, *ICD-30 – Interface Control Document for Direct Feed LAW Feed*. These four tanks will be used for the following purposes:

- 241-AP-105 – Staging and characterization tank
- 241-AP-107 – DFLAW feed tank
- 241-AP-106 – Interim pretreated LAW storage tank
- 241-AP-108 – Plant wash and flush liquids receipt tank.

²⁸ Some campaigns will be slightly more than 1 Mgal and some will be slightly less than 1 Mgal.

²⁹ Waste Group A DSTs are tanks that, due to waste composition and quantities, have the potential for a spontaneous buoyant displacement gas release event. A listing of these tanks is in Table 5-3 of RPP-10006, Rev. 17, *Methodology and Calculations for the Assignment of Waste Groups for the Large Underground Waste Storage Tanks at the Hanford Site*.

Concentrate from the EMF will be recycled to the LAW Vitrification Facility as feed³⁰ and the condensate from the EMF will be routed to the Liquid Effluent Retention Facility (LERF) for treatment in the Effluent Treatment Facility (ETF). Solids removed during filter and IX column flushes will be returned to the tank farms (tank 241-AP-108 [AP-108]), while spent IX columns loaded with cesium will be sent to the permitted interim storage pad.

Each DFLAW campaign will be adjusted to 5 or 6 molar sodium (typically, diluted with water),³¹ homogenized, and prepared in the staging and characterization tank (241-AP-105 [AP-105]). Thereafter, the waste will be transferred (decanted) to tank 241-AP-107 (AP-107), the DFLAW feed tank, where it will be allowed to mix prior to being sampled and qualified against the limits in the waste acceptance criteria for TSCR per ICD-30. After treatment through the TSCR system, the treated feed will accumulate in tank AP-106 awaiting batch transfer to the LAW Vitrification Facility.

Campaign 1 is already prepared and is stored in the DFLAW feed tank (tank AP-107). Constituent concentrations have already been screened against all the waste acceptance requirements of ICD-30. The screening results are summarized in RPP-RPT-57991, *River Protection Project Integrated Flowsheet*.

³⁰ Tank 241-AP-102 may receive filtered EMF feed when the EMF is off-line but melter (vitrification) operations continue.

³¹ This adjustment will be needed to meet the waste acceptance criteria for TSCR, since the majority of supernate waste in the 200 East Area DSTs at the start of DFLAW operations has been concentrated beyond 6 molar sodium by the 242-A Evaporator.

Figure 2-21. Process Flowsheet for Direct-Feed Low-Activity Waste Operations.

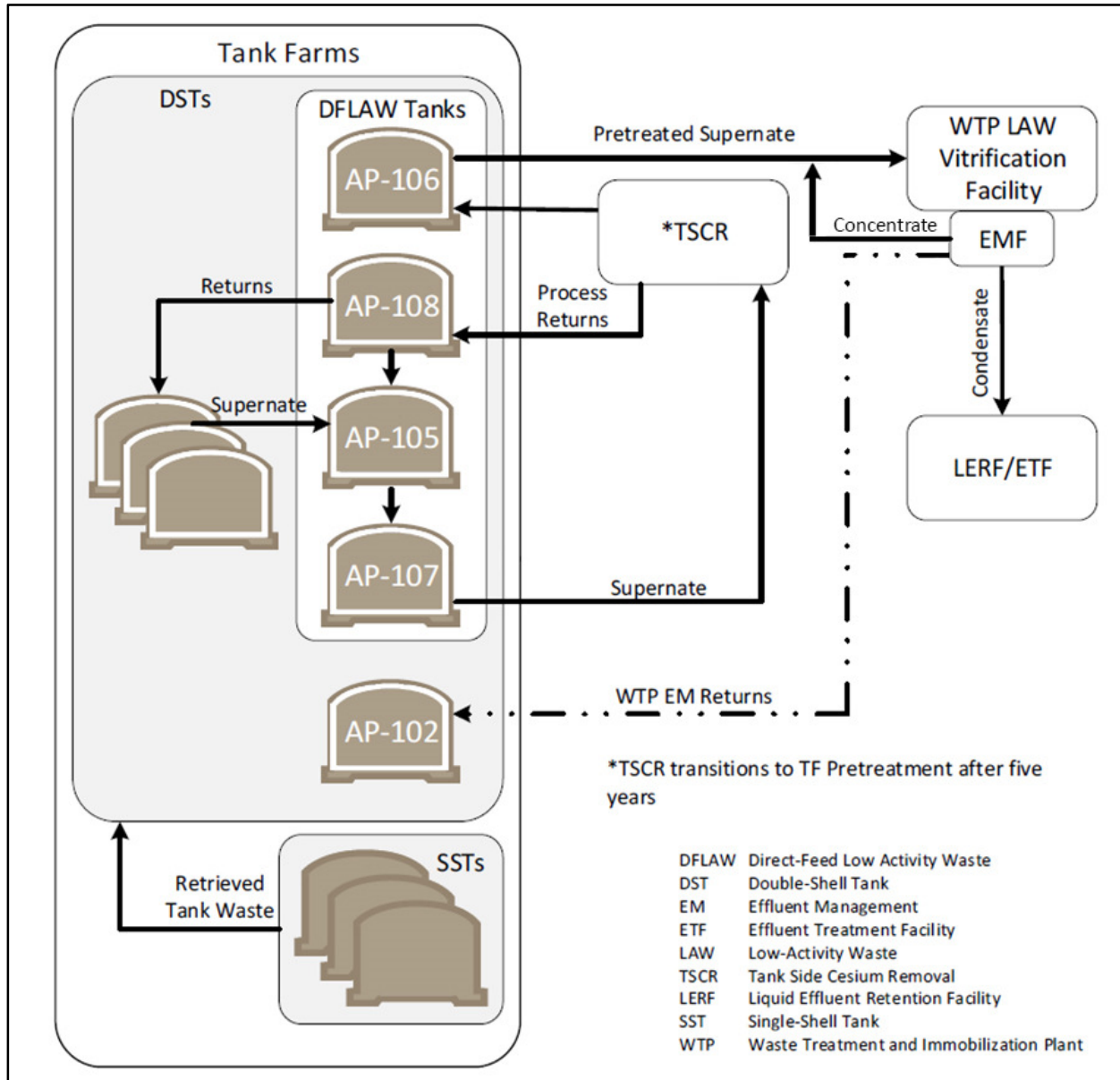

Source: RPP-40149-VOL2, *Integrated Waste Feed Delivery Plan: Volume 2 – Campaign Plan*.

Note: Tanks 241-AP-105 through 241-AP-108 do not contain sludge (HNF-EP-0182, *Waste Tank Summary Report for Month Ending June 30, 2019, Rev. 378*).

Campaign 2 will be prepared in tank AP-105, by decanting some of the current inventory and then adjusting the feed to meet the target sodium molarity using water.

After the first three campaigns, the DFLAW campaigns will include supernate from SSTs. The SST supernate will be derived from dissolved SST saltcake and interstitial liquids. The SST saltcake will be dissolved using water or supernate.³²

Figure 2-21 shows the flowsheet representation of the tank waste processing during DFLAW campaigns. Table 2-4 describes the currently planned sequence of DFLAW campaigns.

Operation of the TSCR system will generate two kinds of process returns: filter backflush containing captured solids and IX column flush. Both will be routed to tank AP-108, a DST, and pretreated in subsequent TSCR campaigns (see Table 2-4). A total of approximately 24.5 Mgal (including filter backflush and IX column flush) will be processed through the TSCR system; due to process returns, molarity adjustment and other operations, approximately 23.5 MGal of pretreated LAW will be vitrified (immobilized in glass) in the LAW Vitrification Facility. (RPP-40149-VOL2, *Integrated Waste Feed Delivery Plan: Volume 2 – Campaign Plan*, Rev. 05A.

Table 2-4. Currently Planned Sequence of Direct-Feed Low-Activity Waste Campaigns. (2 sheets)

| DFLAW Campaign | Original Source Tanks^c (Bolded tanks are DSTs, non-bolded are SSTs) | Staging to AP-107 (start date) | Delivery to TSCR/TFPT (start date) | Delivered to TSCR/TFPT (gal) |
|-----------------------|---|---|---|---|
| 1 | AP-107 | N/A | 3/24/2021 | 938,927 |
| 2 | AP-105 | 11/22/2021 | 11/27/2021 | 988,586 |
| 3 | AP-101, AP-105 | 8/18/2022 | 8/23/2022 | 1,028,778 |
| 4 | AP-101, AZ-102, AX-103, AX-102 | 3/21/2023 | 3/26/2023 | 1,059,501 |
| 5 | AW-102, AP-105, AP-104, AP-101 | 11/6/2023 | 11/11/2023 | 887,409 |
| 6 | AP-108, AW-102, AP-105, AP-106 | 5/14/2024 | 5/19/2024 | 865,227 |
| 7 | A-101, AP-108, AP-101, AX-101, A-102... | 11/13/2024 | 11/18/2024 | 1,065,002 |
| 8 | AY-101, AP-108, AN-101, A-101... | 6/18/2025 | 6/23/2025 | 908,368 |
| 9 | AW-105, AX-101, AP-108, AW-102... | 12/30/2025 | 1/14/2026 | 1,009,284 |
| 10 ^a | AX-101, AN-104, AP-108, AW-102... | 7/27/2026 | 8/1/2026 | 1,002,448 |
| 11 | AN-104, A-103, AP-106, AW-105... | 12/16/2026 | 12/21/2026 | 908,152 |
| 12 | AN-103, A-103, SY-101, AN-104... | 5/4/2027 | 5/9/2027 | 1,064,983 |
| 13 | AP-103, AP-104, AN-103, AW-103 | 11/3/2027 | 11/8/2027 | 934,687 |
| 14 | S-105, S-109, SY-103, AP-103, AN-104... | 4/11/2028 | 4/26/2028 | 771,488 |
| 15 | AN-105, S-109, S-105, SY-103 | 8/31/2028 | 9/4/2028 | 1,064,984 |
| 16 | S-109, AN-105, S-105, S-102 | 2/16/2029 | 3/3/2029 | 917,412 |

³² Supernate use will minimize the addition of water or chemicals (e.g., sodium hydroxide).

**Table 2-4. Currently Planned Sequence of Direct-Feed Low-Activity Waste Campaigns.
(2 sheets)**

| DFLAW Campaign | Original Source Tanks^c (Bolded tanks are DSTs, non-bolded are SSTs) | Staging to AP-107 (start date) | Delivery to TSCR/TFPT (start date) | Delivered to TSCR/TFPT (gal) |
|--------------------------|---|---|---|---|
| 17 | S-109, AN-105 , S-105, SY-103 , AN-104 | 7/21/2029 | 7/26/2029 | 849,812 |
| 18 | AP-103 , AW-103 , AY-101 , AX-101... | 12/10/2029 | 12/15/2029 | 967,779 |
| 19 | S-103, AP-103 , S-109, AW-103 , AY-101 ... | 5/21/2030 | 5/26/2030 | 992,323 |
| 20 | SX-106, AW-101 , S-106, AN-105 , S-103... | 11/5/2030 | 11/10/2030 | 948,484 |
| 21 | AW-101 , AN-105 , SX-106, S-103, S-106... | 4/15/2031 | 4/20/2031 | 950,762 |
| 22 | AW-106 , S-106, AN-105 , AW-101 , S-103... | 9/26/2031 | 10/1/2031 | 971,187 |
| 23 | AW-106 , SX-102, S-108, S-106 | 3/13/2032 | 3/18/2032 | 1,036,712 |
| 24 | S-108, SX-106, SX-102, S-103, AW-106 ... | 9/6/2032 | 9/11/2032 | 841,358 |
| 25 | AN-103 , S-108, SX-106, AW-106 ... | 1/28/2033 | 2/2/2033 | 770,290 |
| 26 | AN-103 , S-108, SX-105, AW-106 ... | 6/18/2033 | 6/22/2033 | 804,492 |
| Total^b | | — | — | 24.5 Mgal |

Source: From RPP-40149-VOL2 Rev 05A, *Integrated Waste Feed Delivery Plan: Volume 2 – Campaign Plan*.

^a Campaign 10 is initial feed to TFPT.

^b Total is for Campaigns 1 to 26 only. Total includes filter backflush and IX column flush. Due to process returns, molarity adjustments and other operations, processing 24.5 Mgal in DFLAW results in approximately 23.5 Mgal that will be transferred to the LAW Vitrification Facility.

^c Original source tanks with more than 1% of campaign; ... indicates additional minor source tanks

DFLAW = direct-feed low-activity waste
DST = double-shell tank

N/A = not applicable
SST = single-shell tank

TFPT = tank farms pretreatment
TSCR = tank side cesium removal

2.5.1.4 Effluent Management Facility

The EMF has a footprint of approximately 32,000 ft² and is being constructed within the 65 acres of the WTP complex.³³ It houses tanks, an evaporator, and process piping systems required to manage effluent from the LAW and LAB facilities. The concentrated effluent from its evaporator will be sent to the LAW Vitrification Facility for vitrification.

The EMF includes an evaporator that will be used to reduce the amount of liquid effluent from the LAW Vitrification Facility's radioactive liquid waste disposal system, the LAB's radioactive liquid waste disposal system, and the caustic scrubber effluent from the LAW Vitrification Facility's secondary offgas/vessel vent process system.

³³ EMF information is included as additional background information, to describe its use to recycle LAW Vitrification Facility effluent. The EMF is outside the scope of this Draft WIR Evaluation.

2.5.1.5 Filtration and Cesium Removal System

Phase 1 of the DFLAW approach will use a single TSCR unit, followed in Phase 2 by either an additional TSCR unit or a filtration and cesium removal facility to provide the necessary throughput to support full operation of the LAW Vitrification Facility. The cesium removal system for DFLAW (both Phase 1 and Phase 2) will use non-elutable³⁴ IX columns that permanently bind the cesium to the IX media.³⁵

The TSCR system will be a modular, skid-mounted unit located just east of AP Tank Farm (see Figure 2-22), designed to receive tank supernatant waste, use filters to remove residual suspended solids, and treat the tank supernatant waste by removing radioactive cesium using an IX subsystem.

Figure 2-22. Tank-Side Cesium Removal Location East of 241-AP Tank Farm.

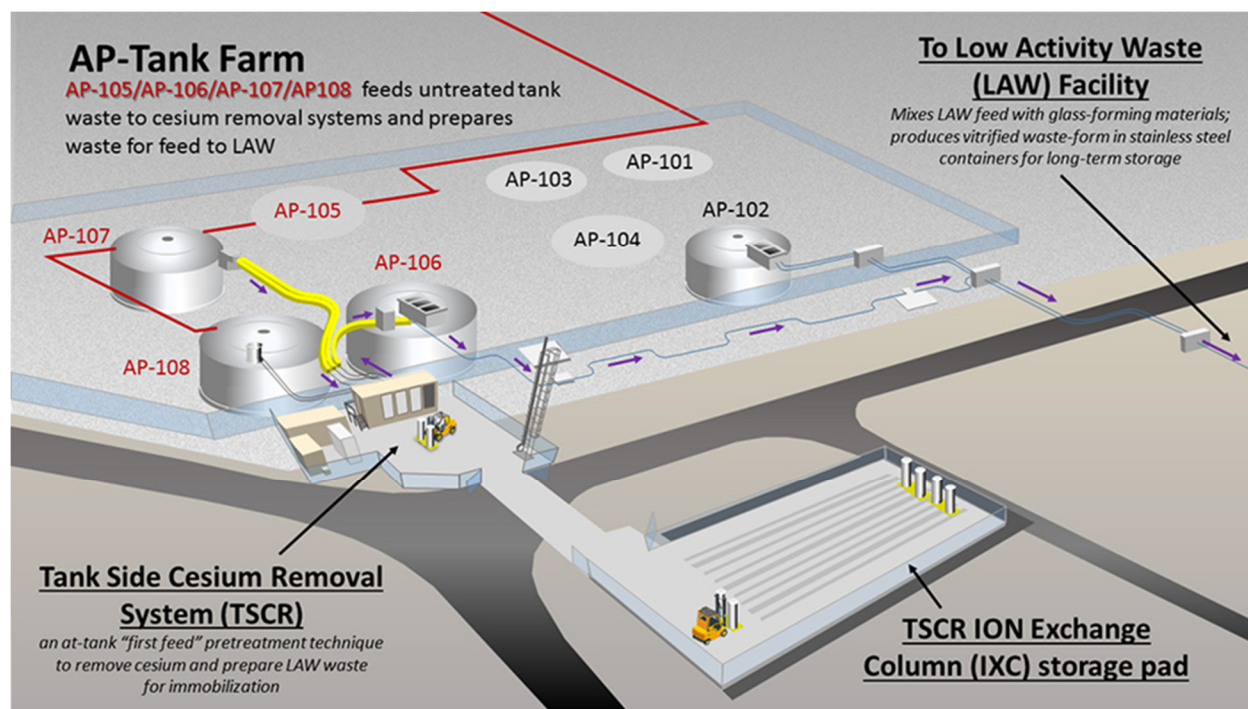

³⁴ Non-elutable resin refers to non-reusable resin that permanently captures the radionuclides. Elutable resin is a re-usable resin that is designed to be flushed with a suitable chemical to release the radionuclides from the resin, thereby allowing re-use of the resin.

³⁵ DOE previously planned to use spherical resorcinol-formaldehyde (sRF) resin in the LAWPS approach. DOE decided to use crystalline silicotitanate (CST) resin for the DFLAW approach (84 FR 424, "Amended Record of Decision for the Direct Feed Low-Activity Waste Approach at the Hanford Site, Washington"). Both IX media (sRF and CST) function in the same way – the cesium is removed selectively by the media while the liquid flows past the engineered media. Cesium removal tests performed at the Hanford Site 222-S Laboratory demonstrated that the CST media was successful in removing greater than 99.9% of ¹³⁷Cs (SESC-EN-RPT-005, *Hanford Complexant Concentrate Cesium Removal Using Crystalline Silicotitanate*; SESC-EN-RPT-006, *Hanford Salt Cake Cesium Removal Using Crystalline Silicotitanate*).

The TSCR system (see Figure 2-23) will consist of filtration and cesium IX unit process operations located inside of a process enclosure, approximately the size of an intermodal shipping container (i.e., 35 ft × 10 ft × 14 ft).

Figure 2-23. Tank-Side Cesium Removal System Concept Diagram.

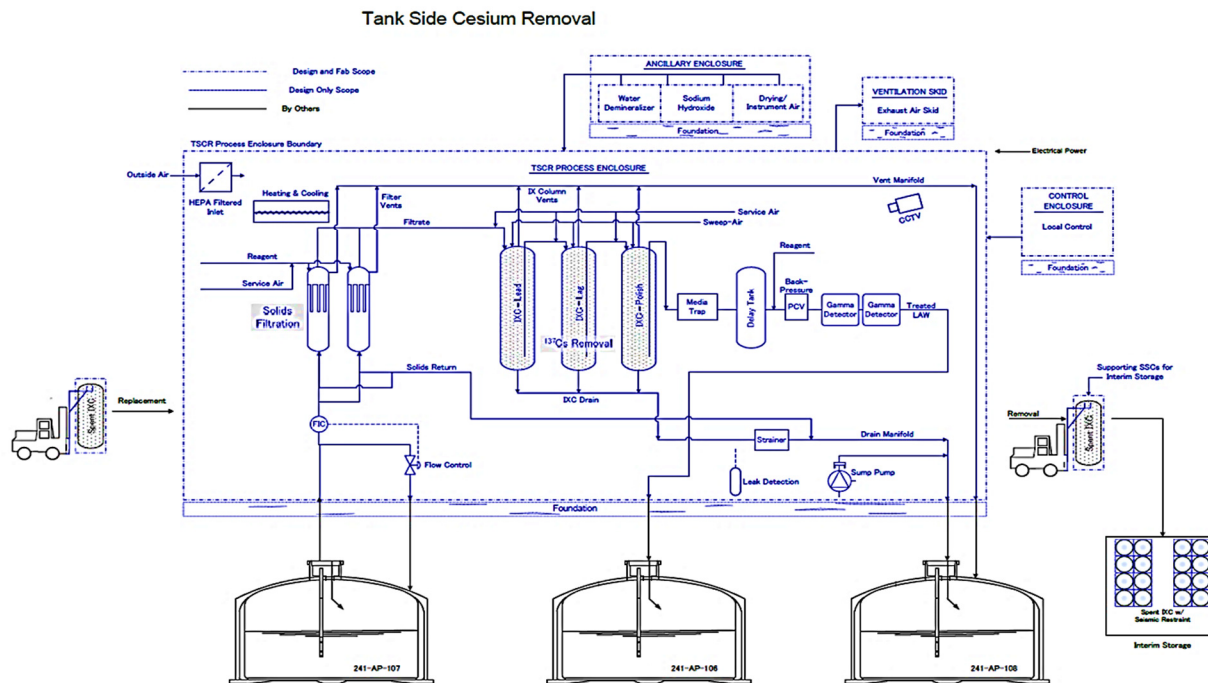

Source: *Tank Side Cesium Removal Demonstration Project*, 2019, https://www.hanford.gov/files.cfm/HAB_TSCR_03-13-19-scs_AJZ.PDF

Waste feed will be delivered from tank AP-107 to the TSCR process enclosure interface via a transfer pump and hose-in-hose transfer lines. The TSCR unit will contain three IX columns. When one or more of the IX columns becomes fully loaded with cesium, the spent columns will be taken out of service, dewatered, dried, and replaced.³⁶ The throughput of a single TSCR unit is approximately 5 gallons per minute. Each of the IX columns used with the TSCR unit will be approximately 10 ft tall with a 34-inch outside diameter, a media volume of 157.5 gallons, and a maximum cesium-137 loading of about 141,000 Ci [RPP-CALC-62497, *Tank Side Cesium Removal (TSCR) IXC-150 Sizing*].³⁷

³⁶ The dewatering of the loaded IX columns will entail displacing the liquid waste remaining in the IX column with caustic solution followed by a water rinse. The caustic and water flush will be returned to an AP Farm DST (AP-108). Although outside the scope of this Draft WIR Evaluation, each spent column then will be air-dried following flushing. The drying process is expected to consist of draining an IX column and then pushing roughly 30 ft³ per minute of dry air through each IX column. Air and liquids generated during the drying process will be managed with other DFLAW effluents to ensure that there are no inadvertent releases to the environment. The loaded columns will be placed on a permitted IX column storage pad.

³⁷ The IXC-150 design loading limit is 141,600 Ci of Cs-137. At full operation of a single TSCR, DOE expects that, on average, two loaded columns may be generated each month. Therefore, DOE estimates that approximately 120 IX columns may be generated from five years of operation of a single TSCR unit in Phase 1.

The process effluents (returns) from the TSCR system will be sent to an AP Farm DST (AP-108) through hose-in-hose transfer lines. Pretreated waste, with insoluble radionuclides and cesium removed, will be stored in another AP Farm DST (AP-106) and pumped in batches through buried transfer lines to the LAW Vitrification Facility for immobilization.

Under Phase 2 of the DFLAW, DOE anticipates adding another TSCR unit to provide the necessary throughput to support full operation of the LAW Vitrification Facility, or constructing and using a filtration and cesium removal facility to meet the WTP LAW Vitrification Facility throughput (10 gallons per minute). If used, the second TSCR unit is expected to be located adjacent to the existing Phase 1 TSCR and operate in the same manner as the first.

As currently envisioned for the site, a filtration and cesium removal facility (if used) may have a footprint of approximately 20,000 ft² and be located immediately south of AP Farm and southwest of the Phase 1 TSCR unit (see Figure 2-20). The filtration and cesium removal facility is expected to be a cast-in-place concrete and steel facility designed to receive tank supernatant waste from the DST system, filter out suspended solids, and treat the tank supernatant waste by removing radioactive cesium using an IX subsystem. The filtration and cesium removal facility will include pre-filtration and cesium IX subsystem operations located inside of a main process building.

Waste feed will be delivered from a DST to the process enclosure interface via a transfer pump and an encased waste transfer line. The pre-filtration subsystem will consist of a filter unit that could be back-flushed and/or chemically cleaned to remove fouling. Filter flush solution consisting of back-pulsed waste with solids removed from the filter will be sent back to an AP Farm DST. The LAW feed, with the cesium removed, will then be transferred to another AP Farm DST via a dedicated waste transfer line. From the AP Farm DST, the waste will be fed to the LAW Vitrification Facility for immobilization.

If a filtration and cesium removal facility is used, the main process building may contain three IX columns. When fully loaded, an IX column will be taken out of service, dewatered, dried, and replaced, as described above for the TSCR IX column.³⁸ The pretreated LAW will flow to a designated AP Farm DST, be sampled periodically to confirm that it meets the waste acceptance criteria for the LAW Vitrification Facility, and then pumped in batches through a buried transfer line to the LAW Vitrification Facility for vitrification. Each of the IX columns used with the filtration and cesium removal facility may be larger than those used with the TSCR unit (approximately 12 ft tall with a 38-in. outside diameter) and may have a cesium load range from approximately 100,000 Ci to a maximum loading of about 300,000 Ci. At full operation of the filtration and cesium removal facility, DOE expects that, on average, two loaded columns may be generated each month.

2.5.2 Tank 241-AP-106

To support the start of TSCR operations using the DFLAW approach, tank AP-106 is being repurposed to make it suitable for interim storage of pretreated LAW feed, before the pretreated LAW feed is transferred in batches to the LAW Vitrification Facility. Prior to repurposing,

³⁸ The loaded columns will be placed on the IX Column Storage Pad.

tank AP-106 stored supernatant waste that did not meet the waste acceptance criteria of the LAW Vitrification Facility.

The waste from tank AP-106 is undergoing a series of processing steps to repurpose the tank, in order to serve as the pretreated LAW storage tank (Figure 2-24). This process began by first pumping out as much of the supernate as possible, followed by a number of bulk dilution and decanting steps to reduce the ^{137}Cs in the tank.

Figure 2-24. Simplified Tank 241-AP-106 Repurposing Strategy.

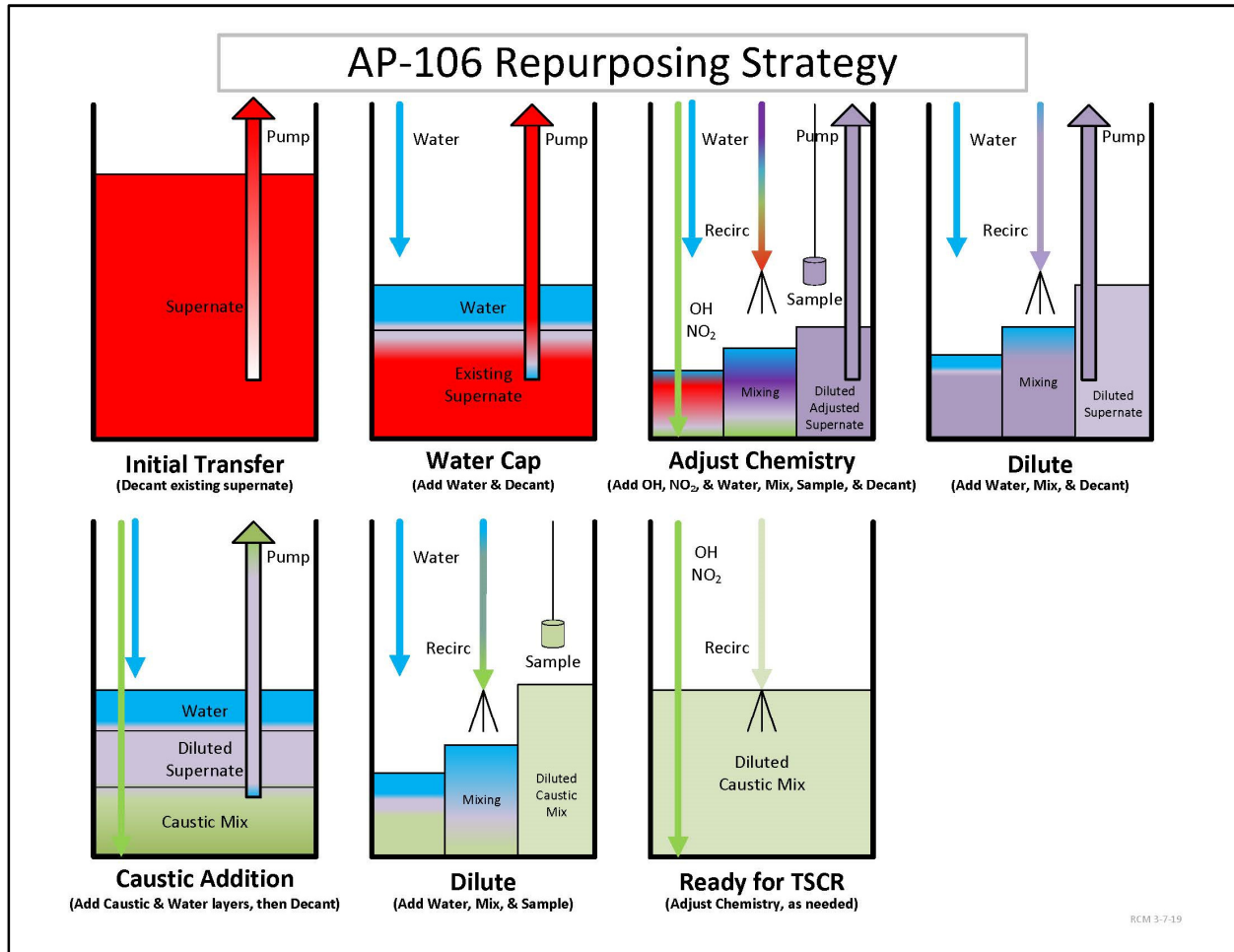

TSCR = Tank-Side Cesium Removal

The next steps included injection of a caustic solution, followed by more water additions and dilution steps. Process samples have been obtained to determine the effectiveness of this process. Process steps may be adjusted as needed based on the mixing behavior observed.

The final steps of the process will include a water addition and waste recirculation, followed by sampling and analysis to confirm that the waste, once mixed with pretreated waste from the first phase of TSCR operations, will comply with LAW Vitrification Facility waste feed acceptance requirements. Detailed information on the repurposing process can be found within Appendix E

based on RPP-PLAN-62353, *Tank 241-AP-106 Cs-137 Removal for Repurposing Process Control Plan*.

2.5.3 The Low-Activity Waste Vitrification Facility

The LAW Vitrification Facility has two melters (TC&WM EIS [DOE/EIS-0391] Appendix E). Each melter system includes feed-preparation vessels; the large-capacity, joule-heated, locally-shielded, ceramic melter; a VLAW product container filling system; and an offgas treatment system. Each LAW melter is approximately 20 ft wide by 30 ft long by 16 ft high, and weighs approximately 300 tons when empty.

LAW feed from the EMF and TSCR will be sent by a transfer line to the melter feed preparation vessels, where glass formers will be added and blended to form a uniform batch for the vitrification melter. The melter feed, in the form of agitated slurry, will be fed continuously to the LAW melters. The feed will enter the melter from the top above the melt pool. The melt pool will be maintained at a temperature of approximately 1,050 to 1,150 °C (1,900 to 2,100 °F). Air bubblers will be used to agitate the glass pool to improve heat transfer and thereby increase the glass production rate.

The nonvolatile components will undergo chemical reactions and form oxides or other compounds that dissolve in the molten glass pool. Water and volatile components present in the liquid feed will evaporate or decompose. The volatile components will be drawn off through the melter offgas treatment system, go through a submerged bed scrubber (SBS) and Wet Electrostatic Precipitator (WESP). The LAW melter offgas system consists of two stages of high-efficiency particulate air (HEPA) filters for the purpose of removing radioactive particulates from the offgas, in order to achieve compliance with both environmental and occupational dose limits. Downstream of the HEPA filters are two carbon adsorber beds filled with granular activated carbon media.³⁹ By design, the purpose of these beds is to remove mercury, halides, and acid gases as well as ¹²⁹I.

The liquid condensate from the SBS and WESP, which will contain volatile key radionuclides (including ⁹⁹Tc and ¹²⁹I) from the melter, will be transferred to the EMF. The EMF design includes flexibility to route the EMF evaporator concentrate (also referred to as EMF evaporator bottoms) as follows: 1) recycle back to the LAW Vitrification Facility for blending with incoming DFLAW feed; 2) return back to the Hanford tank farms DSTs; and 3) purge via a tanker truck load-out station (RPP-RPT-58971, *Effluent Management Facility Evaporator Concentrate – Purge Alternatives Evaluation*). The EMF evaporator condensate will be sent to the ETF for further treatment prior to disposal.⁴⁰

³⁹ The HEPA filters and carbon bed adsorbers are not included in waste (VLAW) addressed by this Draft WIR Evaluation.

⁴⁰ Although not within the scope of this Draft WIR Evaluation, the ETF, located in the 200 East Area, treats wastewater from Hanford cleanup work. Prior to treatment, the wastewater is stored in the LERF basins. These basins are located adjacent to ETF. The liquid effluent resulting from the treatment process is discharged to a State-approved land disposal site. The removed solids will be incorporated into a cementitious waste form and disposed of at the IDF.

The molten glass will be moved from the melter by an airlift system into the VLAW containers, which are illustrated in Figure 2-25. Suitable dry inert filler, such as glass or sand, will be added on top of the VLAW in the container if necessary, to ensure that it is at least 90% full to meet WAC Dangerous Waste Regulation 173-303-665, “Landfills,” subsection (12) “Special requirements for containers” and to meet DOE M 435.1-1 Chapter IV.G.(1)(d)1. requirement that “[v]oid spaces within the waste ... shall be reduced to the extent practical.” The container will be sealed and cooled. The cooled containers of VLAW will then be transported to the IDF for disposal (24590-WTP-PL-RT-03-001, *ILAW Product Compliance Plan*.)

Figure 2-25. Vitrified Low-Activity Waste Container.

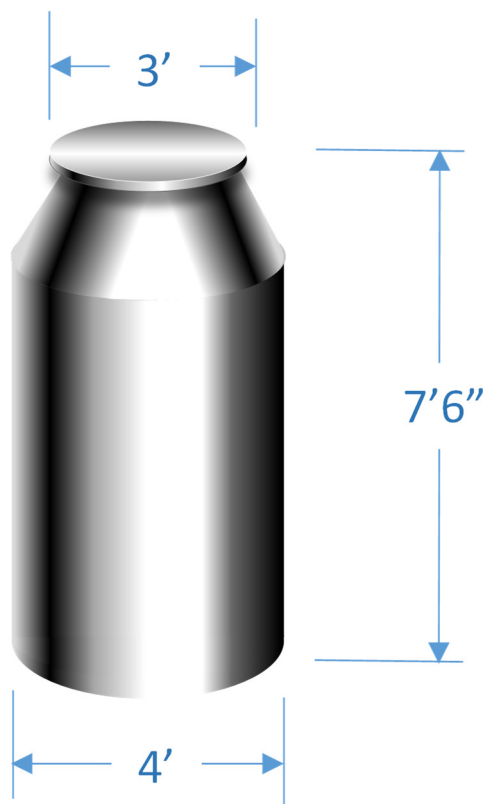

2.5.4 Estimated Volume and Characteristics of the Vitrified Low-Activity Waste

The total quantity of VLAW containers produced using the DFLAW approach will be approximately 13,500 containers. This is a portion (about 10%) of the total evaluated by RPP-RPT-59958 (hereinafter referred to as the IDF PA).

The key WTP contractual requirements⁴¹ for the VLAW and its container are:

- A waste form consisting of borosilicate glass inside a cylindrical container

⁴¹ DOE 2019 WTP Contract No. DE-AC27-01RV14136, Section C, Statement of Work, <https://www.hanford.gov/page.cfm/DOE-ORPPPrimeContracts/BNICContract>

- An average bulk density of approximately 2.58 g/cm³ (kg/L) at 20 °C
- Each container must be at least 90% filled with glass and inert filler
- The concentration of ¹³⁷Cs must be less than 0.3 Ci/m³
- The concentration of ⁹⁰Sr must be less than 20 Ci/m³
- Overall radionuclide concentrations must be less than or equal to Title 10, CFR, Part 61, Subpart D—Technical Requirements for Land Disposal Facilities, §61.55, “Waste classification” (10 CFR 61.55) Class C limits
- Dose rates on the external surface of the waste packages less than 500 mrem/hr
- Fully loaded containers must be closed and capped.

2.6 THE INTEGRATED DISPOSAL FACILITY

DOE currently plans to dispose of the VLAW generated by the DFLAW approach in the onsite IDF (RPP-15833, *System Specification for the Integrated Disposal Facility*). The IDF is a land disposal facility with enough capacity for the DFLAW VLAW addressed in this Draft WIR Evaluation.⁴² Figure 2-26 shows the IDF.

The IDF consists of a single landfill having expandable cells 1 and 2. One cell of the landfill is permitted and the other cell is expected to be permitted as a RCRA-compliant landfill system by the State of Washington for the hazardous wastes. The entire landfill is authorized by DOE for radiological constituents.

The IDF final size will be 555 m long by 446 m wide and 14 m deep (1,820 ft long by 1,463 ft wide and 46 ft deep), with a currently-planned capacity of 900,000 m³ (1.18 million yd³) of LLW and MLLW (WA7 89000 8967, *Hanford Facility Resource Conservation and Recovery Act Permit, Dangerous Waste Portion Revision 8C for the Treatment, Storage, and Disposal of Dangerous Waste*, “Part III, Operating Unit 11 Integrated Disposal Facility Fact Sheet”). The IDF cells include a double liner, a leachate collection and removal system, and a leak detection system. The liner system complies with RCRA requirements for hazardous waste landfills.

At final closure, the IDF will be: covered with a closure cap designed and constructed to provide long-term minimization of migration of liquids through the closed landfill; function with minimum maintenance; promote drainage and minimize erosion or abrasion of the cover; accommodate settling and subsidence so that the cover’s integrity is maintained; and have a

⁴² The PA for the IDF assumed all LAW would be vitrified; DOE has not made any decision on supplemental LAW treatment.

permeability less than or equal to the permeability of any bottom liner system or natural subsoils present (Section 3.2.4.1 of the IDF PA).

Figure 2-26. Integrated Disposal Facility Cells 1 and 2.



3.0 WASTE DETERMINATION CRITERIA

Section Purpose

The purpose of this section is to describe the criteria applicable to this Draft WIR Evaluation.

Section Contents

This section provides brief background information on DOE criteria that apply to this Draft WIR Evaluation.

Key Points

Applicable criteria appear in DOE M 435.1-1, *Radioactive Waste Management Manual*.

This Draft WIR Evaluation assesses whether the VLAW will meet the criteria in Chapter II.B.(2)(a) of DOE M 435.1-1, for determining that the VLAW is incidental to reprocessing, is not HLW and may be managed as LLW.

This Draft WIR Evaluation was prepared in accordance with DOE M 435.1-1 following guidance in DOE G 435.1-1, *Implementation Guide for use with DOE M 435.1-1*.

The criteria for a WIR evaluation in Chapter II.B.(2)(a) of DOE M 435.1-1 are, in relevant part, that the wastes:

1. “Have been processed, or will be processed, to remove key radionuclides to the maximum extent that is technically and economically practical; and
2. Will be managed to meet safety requirements comparable to the performance objectives set out in 10 CFR Part 61, Subpart C, *Performance Objectives*; and
3. Are to be managed, pursuant to DOE’s authority under the *Atomic Energy Act of 1954*, as amended, and in accordance with the provisions of Chapter IV of this Manual, provided the waste will be incorporated in a solid physical form at a concentration that does not exceed the applicable concentration limits for Class C low-level waste as set out in 10 CFR 61.55, *Waste Classification*[.]”^{43, 44}

⁴³ This provision in DOE M 435.1 also includes the following language: “or will meet alternative requirements for waste classification and characterization as DOE may authorize.” DOE is not using or relying upon this language in this Draft WIR Evaluation.

⁴⁴ Class C concentration limits refer to the NRC classification system for LLW in 10 CFR 61.55. Section 6 of this Draft WIR Evaluation describes these limits and demonstrates that the VLAW (glass) will not exceed the concentration limits for Class C LLW.

DOE also considered applicable guidance in DOE G 435.1-1 in preparing this Draft WIR Evaluation.

As will be demonstrated in the next three sections of this Draft WIR Evaluation, this Draft WIR Evaluation shows that the VLAW meets the applicable criteria in Chapter II.B.(2)(a) of DOE M 435.1-1, and may be managed and disposed of as LLW.

4.0 THE WASTE WILL BE PROCESSED TO REMOVE KEY RADIONUCLIDES TO THE MAXIMUM EXTENT THAT IS TECHNICALLY AND ECONOMICALLY PRACTICAL

Section Purpose

The purpose of this section is to identify key radionuclides and evaluate whether key radionuclides will be removed to the maximum extent that is technically and economically practical.

Key Point

The key radionuclides are those radionuclides listed in Tables 1 and 2 of 10 CFR 61.55, and those radionuclides that are important to meeting the performance objectives and performance measures for disposal of LLW in the IDF.

4.1 KEY RADIONUCLIDES

This section begins with a brief introduction that describes the various factors considered, provides additional information on these factors, discusses their relevance to key radionuclide identification, and concludes with the identification of key radionuclides for this Draft WIR Evaluation, using a risk-informed approach.

4.1.1 Introduction

Identification of the key radionuclides in the VLAW includes consideration of the following information:

- DOE G 435.1-1 guidance on identification of key radionuclides
- NRC requirements for classification of radioactive waste for near-surface disposal that appear in 10 CFR 61.55
- Radionuclides known to be present in the Hanford tank wastes
- Radionuclides of importance in the IDF PA.

Consideration of this information will ensure that those radionuclides present in the VLAW that could contribute significantly to radiological risks to workers, the public, or the environment are identified and taken into account.

4.1.2 U.S. Department of Energy Guidance on Identification of Key Radionuclides

The DOE’s guidance on identification of key radionuclides is provided in Chapter II.B page II-22 of DOE G 435.1-1, with the applicable portion reading as follows:

“... it is generally understood that [the term] key radionuclides applies to those radionuclides that are controlled by concentration limits in 10 CFR 61.55. Specifically these are: long-lived radionuclides, C-14, Ni-59, Nb-94, Tc-99, I-129, Pu-241, Cm-242, and alpha emitting transuranic nuclides with half-lives greater than five years and; short-lived radionuclides, H-3, Co-60, Ni-63, Sr-90, and Cs-137. In addition, key radionuclides are those that are important to satisfying the performance objectives of 10 CFR Part 61, Subpart C [for near-surface radioactive waste disposal facilities].”

Key radionuclides identified in this Draft WIR Evaluation consider radionuclides in Tables 1 and 2 in 10 CFR 61.55. This Draft WIR Evaluation also considers radionuclides important to meeting requirements comparable to the performance objectives in 10 CFR Part 61, Subpart C, specifically those radionuclides of importance identified in the IDF PA (RPP-RPT-59958).

4.1.3 U.S. Nuclear Regulatory Commission 10 CFR 61.55 Requirements

The radionuclides listed in the guidance found in DOE G 435.1-1 appear in 10 CFR 61.55 in the form of two tables, which are reproduced here as Table 4-1 and Table 4-2. The concentrations given in these tables are used for LLW classification purposes. LLW classification is determined by concentrations of long-lived radionuclides, by concentrations of short-lived radionuclides, or by both in those cases where the waste contains both types of radionuclides using a sum of fractions approach.

Table 4-1. Long-Lived Radionuclides.

| Radionuclides | Concentration |
|---|------------------------|
| ¹⁴ C | 8 Ci/m ³ |
| ¹⁴ C in activated metal | 80 Ci/m ³ |
| ⁵⁹ Ni in activated metal | 220 Ci/m ³ |
| ⁹⁴ Nb in activated metal | 0.2 Ci/m ³ |
| ⁹⁹ Tc | 3 Ci/m ³ |
| ¹²⁹ I | 0.08 Ci/m ³ |
| Alpha Emitting Transuranic nuclides with half-life greater than 5 years | 100 nCi/g |
| ²⁴¹ Pu | 3,500 nCi/g |
| ²⁴² Cm | 20,000 nCi/g |

Reproduced Table 1 of 10 CFR 61.55, “Waste classification.”

The waste is Class A if the concentration does not exceed 0.1 times the values in Table 4-1.

Table 4-2. Short-Lived Radionuclides.

| Radionuclides | Concentration (Ci/m ³) | | |
|--|------------------------------------|-----------------------|-----------------------|
| | Column 1 (Class A) | Column 2 (Class B) | Column 3 (Class C) |
| Total of all radionuclides with less than 5 year half-life | 700 | * | * |
| ³ H | 40 | * | * |
| ⁶⁰ Co | 700 | * | * |
| ⁶³ Ni | 3.5 | 70 | 700 |
| ⁶³ Ni in activated metal | 35 | 700 | 7,000 |
| ⁹⁰ Sr | 0.04 | 150 | 7,000 |
| ¹³⁷ Cs | 1 | 44 | 4,600 |

Source: Reproduced Table 2 of 10 CFR 61.55, "Waste classification."

*There are no limits established for these radionuclides in Class B or C wastes. Practical considerations such as the effects of external radiation and internal heat generation on transportation, handling, and disposal will limit the concentrations for these wastes. These wastes shall be Class B unless the concentrations of other nuclides in the table determine the waste to be Class C independent of these nuclides.

4.1.4 Radionuclides Important to the Integrated Disposal Facility Performance Assessment

DOE G 435.1-1 indicates that one criterion for determining key radionuclides in waste is their importance in satisfying safety requirements comparable to the performance objectives of 10 CFR Part 61, Subpart C for the waste disposal facility. Key radionuclides are summarized below based on the results from the IDF PA analysis for the representative member of the public and the inadvertent intruder for both the 1,000-year compliance period and 10,000-year post-closure period. Note that the details of the performance objectives are further described in Section 5.0 of this Draft WIR Evaluation.

4.1.4.1 All-Pathways Dose Performance Objective

The IDF PA analysis shows that the air pathway is the principal contributor to the all-pathways dose for the representative member of the public during the 1,000-year post-closure compliance period. Iodine-129 is the predominant contributor to dose from the air pathway during the 1,000-year post-closure compliance period and the projected dose is about 0.19 mrem/yr, which is a factor of 50 below the 10 mrem/yr air pathway performance objective and a factor of 130 below the 25 mrem/yr all-pathways performance objective. There is no contribution to dose from the groundwater pathway during the 1,000-year post-closure compliance period.

The projected dose during the 1,000- to 10,000-year post-closure period is dominated by the release and transport of the mobile radionuclides, ⁹⁹Tc and ¹²⁹I, in the groundwater pathway, primarily from other waste. Both radionuclides contribute to the peak dose. However, the peak all-pathways, base case dose during the 1,000 to 10,000-year-post-closure period is less than 2

mrem/yr, a factor of 10 less than the 25 mrem/yr performance objective applicable during the compliance period.

4.1.5 Inadvertent Intruder Performance Measure

The highest acute dose and chronic dose to a hypothetical human intruder occur immediately following the assumed loss of institutional controls. Due to radionuclide decay, doses following an inadvertent intrusion decrease when intrusions occur later in time. The earliest time assumed for the loss of institutional controls is 100 years after closure of the IDF, but longer durations of institutional controls are also evaluated in the dose calculations in the IDF PA. The intruder dose calculations also demonstrate that, for a fixed intruder time, the acute and chronic doses following an inadvertent intrusion are directly proportional to the inventory that is intercepted by the intrusion. For the inventory considered by the PA, the projected acute dose to the well driller that intrudes into the facility 100 years after closure is 9.3 mrem, which is well below the performance measure of 500 mrem. The projected chronic dose to the hypothetical human intruder 100 years after IDF closure under the rural pasture resident scenario is 43.3 mrem/yr, which is also well below the performance measure of 100 mrem/yr. The key radionuclides most important to the rural pasture scenario due to inadvertent intrusion are ¹³⁷Cs, ³H and ⁹⁰Sr.

The highest dose (both acute and chronic) based on assumed inadvertent intrusion occurs immediately following the intrusion and the dose subsequently decreases due to radionuclide decay of short-lived radionuclides. Therefore, the dose to the hypothetical human intruder during the post-1,000-year sensitivity period is lower than the dose to the hypothetical human intruder during the 1,000-year period after IDF closure.

4.1.6 Summary of Key Radionuclides in the Vitrified Low-Activity Waste

Based on consideration of the factors discussed above, all radionuclides listed in Tables 1 and 2 of 10 CFR 61.55, with the exception of ⁹⁴Nb, are considered to be key radionuclides for the purposes of this Draft WIR Evaluation. Some are of lesser importance due to their low concentrations in the waste, their small dose conversion factors, short half-life, or both. Table 4-3 lists these radionuclides.

Table 4-3. Key Radionuclides. (2 sheets)

| Radionuclide | 10 CFR 61.55 Long-Lived Radionuclides | 10 CFR 61.55 Short-Lived Radionuclides | Radionuclides Important in the IDF PA ^a |
|-------------------------------|---------------------------------------|--|--|
| ³ H ^b | — | X | — |
| ¹⁴ C ^b | X | — | — |
| ⁶⁰ Co | — | X | — |
| ⁵⁹ Ni | X | — | — |
| ⁶³ Ni | — | X | — |
| ⁶⁴ Nb ^c | X | — | — |
| ⁹⁰ Sr | — | X | X |

Table 4-3. Key Radionuclides. (2 sheets)

| Radionuclide | 10 CFR 61.55 Long-Lived Radionuclides | 10 CFR 61.55 Short-Lived Radionuclides | Radionuclides Important in the IDF PA^a |
|--------------------------------|--|---|--|
| ⁹⁹ Tc ^d | X | — | X |
| ¹²⁹ I ^d | X | — | X |
| ¹³⁷ Cs | — | X | X |
| ²²⁸ Rn | — | — | X |
| ²²⁹ Th | — | — | X |
| ²³² Th | — | — | X |
| ²³⁴ U | — | — | X |
| ²³⁸ U | — | — | X |
| ²³⁷ Np ^e | X | — | X |
| ²³⁸ Pu ^e | X | — | — |
| ²³⁹ Pu ^e | X | — | — |
| ²⁴⁰ Pu ^e | X | — | — |
| ²⁴¹ Pu | X | — | — |
| ²⁴² Pu ^e | X | — | — |
| ²⁴¹ Am ^e | X | — | — |
| ²⁴³ Am | X | — | — |
| ²⁴² Cm | X | — | — |
| ²⁴³ Cm ^e | X | — | — |
| ²⁴⁴ Cm ^e | X | — | — |

^a The IDF PA (RPP-RPT-59958, *Performance Assessment for the Integrated Disposal Facility, Hanford Site, Washington*) encompasses other waste in addition to the vitrified low-activity waste (VLAW) addressed by this *Draft Waste Incidental to Reprocessing Evaluation for Vitrified Low-Activity Waste Disposed Onsite at the Hanford Site, Washington*.

^b ³H and ¹⁴C are listed in 10 CFR 61.55, “Waste classification” and are contained in Hanford tank waste, but are not present in the vitrified LAW. These isotopes partition into secondary solid waste during vitrification (IDF PA Rev 01A, Table 3-27).

^c ⁹⁴Nb is a key radionuclide identified in 10 CFR 61.55 that is not applicable to Hanford tank waste. The total amount of ⁹⁴Nb created from 1944 to 1989 in all Hanford reactors is about 0.1 Ci. ⁹⁴Nb is primarily produced in reactors from activation of natural niobium in stainless steel and Inconel, neither of which were used at Hanford in the fuels that were reprocessed. Therefore, ⁹⁴Nb is not a key radionuclide in vitrified LAW (RPP-13489, *Activity of Fuel Batches Processed Through Hanford Separations Plants, 1944 Through 1989*, Table H-1).

^d ⁹⁹Tc and ¹²⁹I are listed in 10 CFR 61.55, “Waste classification” and are contained in Hanford tank waste. The LAW Vitrification Facility is designed to maximize the capture of these radionuclides in the vitrified waste form. The LAW Vitrification Facility offgas system is designed to recycle and/or capture that portion of volatile radionuclides (including ⁹⁹Tc and ¹²⁹I) which are not vitrified (see Section 2.5.3).

^e Alpha-emitting transuranic radionuclides with half-life greater than five years (Table 4.2 of NUREG-0945, 1982, *Final Environmental Impact Statement on 10 CFR Part 61, “Licensing Requirements for Land Disposal of Radioactive Waste”*: Summary and Main Report).

4.2 REMOVAL TO THE MAXIMUM EXTENT TECHNICALLY AND ECONOMICALLY PRACTICAL

4.2.1 Introduction

In evaluating whether key radionuclides will be removed to the maximum extent that is “technically and economically practical,” DOE has considered the guidance in DOE G 435.1-1 as well as the plain meaning of the phrase “technically and economically practical.” This Draft WIR Evaluation also reflects a risk-based approach, consistent with NRC guidance (NUREG-1854, *NRC Staff Guidance for Activities Related to U.S. Department of Energy Waste Determinations – Draft Final Report for Interim Use*).

Removal to the maximum extent “technically and economically practical” is not removal to the extent “practicable” or theoretically “possible.” Nor does the criterion connote removal which may be notionally capable of being done. Rather, the adverbs “technically” and “economically” modify and add important context to that which is contemplated by the criterion.

Moreover, a “practical” approach, as specified in the criterion, is one that is “adapted to actual conditions” (*A Dictionary of Modern English Usage* [Fowler 1930]); “adapted or designed for actual use” (*Random House Unabridged Dictionary* [Random House 1997]); “useful” (Random House 1997); selected “mindful of the results, usefulness, advantages or disadvantages, etc., of [the] action or procedure” (Random House 1997); fitted to “the needs of a particular situation in a helpful way” (Cambridge, 2004, Cambridge Dictionaries Online, Queried 06/16/2014, [“practical”], <http://dictionary.cambridge.org>); “effective or suitable” (Cambridge 2004). Therefore, the evaluation as to whether a particular key radionuclide has been or will be removed to the “maximum extent that is technically and economically practical” will vary from situation to situation, based not only on reasonably-available technologies but also on the overall costs and benefits of deploying a technology with respect to a particular waste stream.

The “maximum extent that is technically and economically practical” standard contemplates, among other things: consideration of expert judgment and opinion; environmental, health, timing, or other exigencies; the risks and benefits to public health, safety, and the environment arising from further radionuclide removal as compared with countervailing considerations that may ensue from not removing or delaying removal; life cycle costs; net social value; the cost (monetary as well as environmental and human health and safety costs) per curie removed; radiological removal efficiency; the point at which removal costs increase significantly in relationship to removal efficiency; the service life of equipment; the reasonable availability of proven technologies; the limitations of such technologies; the usefulness of such technologies; project schedule or funding constraints; and the sensibleness of using such technologies.

What may be removal to the maximum extent technically and economically practical in a particular situation or at one point in time may not be that which is technically and economically practical, feasible, or sensible in another situation or at a prior or later point in time. In this regard, it may not be technically and economically practical to undertake further removal of certain radionuclides because further removal is not sensible or useful in light of the overall benefit to human health and the environment. Such a situation may arise if certain

radionuclides are present in such extremely small quantities that they make an insignificant contribution to potential doses to workers, the public, and the hypothetical human intruder.⁴⁵

4.2.2 Technical Practicality Assessment

4.2.2.1 Direct-Feed Low-Activity Waste Approach

Using the DFLAW approach, key radionuclides will be removed using a series of steps. Phase 1 of the DFLAW approach will begin with in-tank settling, separation (removal by decanting) of the supernate (including dissolved saltcake and interstitial liquids), followed by filtration and cesium removal using IX columns within a TSCR unit. For Phase 2, DOE plans to treat additional supernate (including dissolved saltcake and interstitial liquids) using the same processes with either an additional TSCR unit or a filtration and cesium removal facility.

Both Phase 1 and Phase 2 of the DFLAW approach will entail the following for the tank waste.

- In-tank settling.
- Decanting to separate supernate and dissolved saltcake from the solids in which insoluble, long-lived actinides tend to be entrained.
- Filtering to remove any remaining insoluble radionuclides. Following filtration, no visibly-detectable solids are expected to be present. The majority of the radionuclides present in the resulting liquid will be those radionuclides that are partially or completely soluble, including ¹³⁷Cs, ⁹⁹Tc, ¹²⁹I, and possibly ⁹⁰Sr.
- Passing through crystalline silicotitanate (CST) IX media to remove ¹³⁷Cs, and large fractions of Ca, U, ⁹⁰Sr, Np and Pu if present in soluble form (PNNL-28783, *Dead-End Filtration and Crystalline Silicotitanate Cesium Ion Exchange with Hanford Tank Waste AW-102*).

4.2.2.2 Settling

From the time of early Site operations, the tank waste management process involved neutralizing the acidic waste with sodium hydroxide and sodium carbonate to minimize corrosion of the carbon steel tanks. Under the long-term caustic storage conditions, the tank waste has separated

⁴⁵ The DOE normally would view radionuclides as making an insignificant contribution if the contribution to dose from those radionuclides, in both the expected case and sensitivity analyses, does not exceed any of the following: (1) 10% of the 25-mrem/yr all-pathways annual dose to the public performance objective, (2) 10% of the DOE 100-mrem annual dose limit to the intruder (under all reasonable intruder scenarios), (3) 10% of the DOE 500-mrem acute dose limit to the intruder (under all intruder scenarios), and (4) 10% of the annual worker dose in the relevant provisions of 10 CFR Part 20, "Standards for Protection Against Radiation". This methodology is based on NRC consultation and is intended to be consistent with the guidance and general approach in NUREG-1757, *Consolidated Decommissioning Guidance: Characterization, Survey, and Determination of Radiological Criteria, Final Report*, Vol. 2, which explains that "NRC staff considers radionuclides and exposure pathways that contribute no greater than 10% of the dose criteria to be insignificant contributors." The above-referenced NUREG, which applies to NRC licensees, is being used only as general guidance, and DOE's use of this NUREG as guidance should not be construed to suggest that it is a requirement under DOE M. 435.1-1 or that either the NUREG or 10 CFR Part 20, Subpart E—Radiological Criteria for License Termination is applicable to DOE.

into insoluble solids and liquid fractions. The liquid fraction has also undergone evaporation to result in saltcake (solid) formation upon cooling in the tanks. Today, 36% of the tank waste by volume is in the form of liquid (supernate), 44% in the form of saltcake, and 20% in the form of sludge (all percentages are approximate). Figure 4-1 illustrates the three components of the total tank waste volume in million gallons (Mgal), based on the BBI for the third quarter of 2017 and the approximate associated amounts of total radioactivity in million curies (MCi) as of July 2017.

Figure 4-1. Tank Waste Form Volumes and Estimated Total Activity in the Underground Waste Tanks.

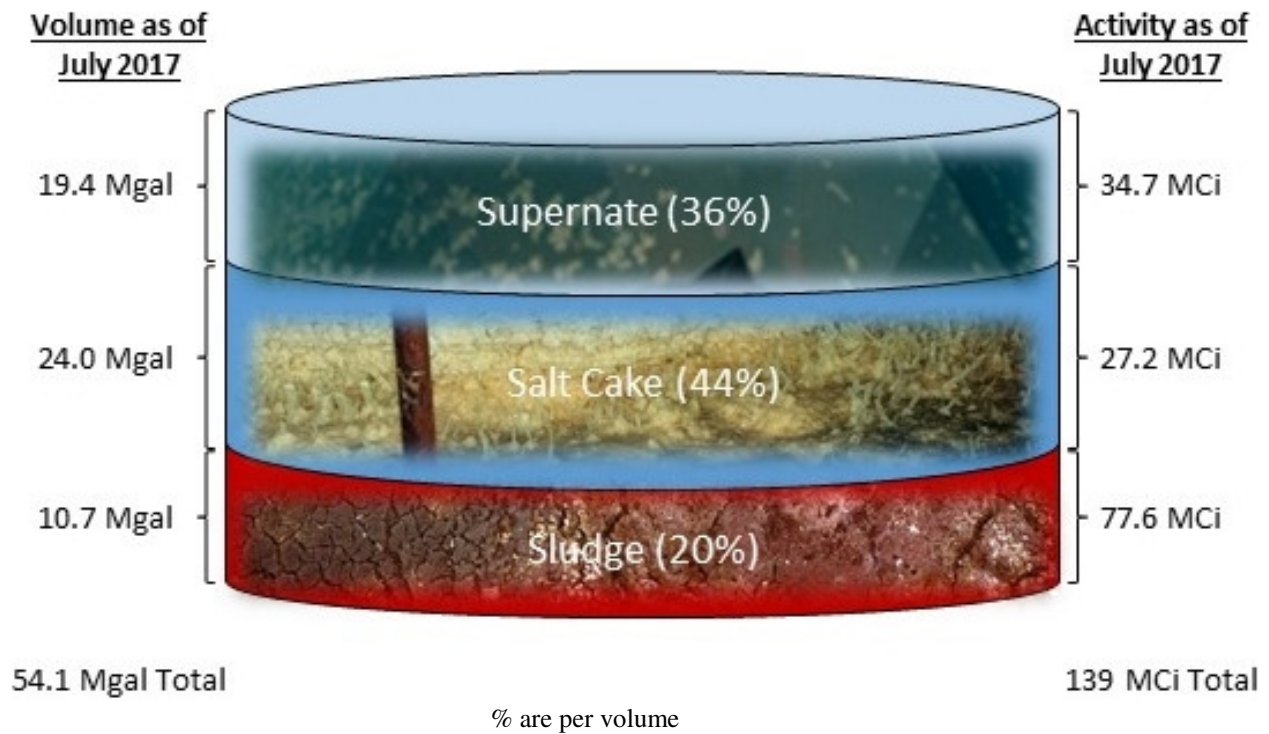

The supernate and saltcake portions of the waste, which together comprise approximately 43.4 Mgal of the tank wastes, consist primarily of sodium hydroxides; sodium salts of nitrate, nitrite, carbonate, aluminate, and phosphate; and hydrous oxides of iron and manganese. The sludge consists primarily of precipitated iron, manganese, and aluminum.

The DFLAW approach concerns the supernate (including dissolved saltcake and interstitial liquids) that contain the short-lived radionuclides, primarily ^{137}Cs (and daughter ^{137}Ba), which may present risk because they produce radiation emissions that, without shielding or controls, may harm humans simply by proximity as well as by inhalation or ingestion. While the supernate and saltcake are roughly 80% by volume of the tank waste, they contain approximately 44% of the curies in the tank waste. In contrast, the sludge in the tank waste consists of the lowest volume but contains nearly all the short-lived ^{90}Sr (and daughter ^{90}Y) and long-lived actinides (e.g., uranium, plutonium, americium, neptunium, and curium) that persist well into the future, may be mobile in the environment, or may pose a risk to humans if inhaled or ingested.

While the sludge is roughly 20% by volume of all tank waste, it is approximately 56% of the curies of all tank waste.⁴⁶

For SSTs covered by the DFLAW approach, the tank waste has previously settled and the supernate has been removed into DSTs. The SST saltcake will be re-dissolved with water or supernate into a liquid fraction and will include interstitial liquid trapped within the saltcake crystalline matrix. The re-dissolved saltcake and interstitial liquid from the applicable SSTs for each DFLAW campaign will be transferred to the DST system.

4.2.2.3 Decanting Process

Once in the DST system, waste will be decanted (separated and removed) from the undissolved solids (saltcake and sludge layers). Decanting is the process of pumping only the liquid fraction from the tank without disturbing the solids. The bulk of the key radionuclides such as strontium, uranium, and the transuranic constituents (neptunium, plutonium isotopes, americium, and curium) are contained in the water-insoluble fraction (i.e., solids) of the tank wastes. The bulk of the ¹³⁷Cs, ⁹⁹Tc, ¹²⁹I, ¹⁴C, and ³H is contained in the soluble fraction of the tank waste. Additional settling/decanting will occur during campaign assembly and qualification process. The settle/decant separations process ensures that the majority of the longer-lived, key radionuclides present in the solids are separated from, and not included in, the LAW feed to TSCR.

4.2.2.4 Filtration

Any residual suspended solids present in the TSCR feed will be filtered using a dead-end filtration process with equivalent performance to a sintered metal filter with a Mott media grade of 5 (24590-WTP-ICF-MGT-17-0002, *Increase Nominal Particle Diameter for Filtration*).⁴⁷ This filtration will remove insoluble compounds which may contain uranium and transuranic particles and will prevent the possibility of criticality in the LAW Vitrification facility (24590-WTP-ICD-MG-01-030).⁴⁸ Bench-scale filtration testing has been performed (PNNL-28780, *Fiscal Year 2019 Filtration of Hanford Tank AP-107 Supernatant*).

4.2.2.5 Cesium Removal and Decontamination Factors

The filtered feed will contain soluble, short-lived⁴⁹ radionuclides, primarily ¹³⁷Cs, which, absent shielding or controls, may be harmful to facility workers by proximity. This feed will contain relatively low amounts of longer-lived radionuclides. Following filtration, ¹³⁷Cs will be removed from the TSCR feed using three IX columns arranged in a lead, lag, polish configuration (Figure 4-2)⁵⁰.

⁴⁶ However, the amount of sludge varies by tank, and for the tanks that will be processed by DFLAW, the sludge percentage is approximately 42% of the curies. Sludge volume in these tanks is approximately 6.8% of their total waste volume, and varies from 0% to 74% in each tank. (Source: HNF-EP-0182 Rev. 379)

⁴⁷ See Appendix F.

⁴⁸ Once particulates have collected on the filter media to the extent that the filter must be cleaned, a standby filter will be brought online and the loaded filter will be taken offline. The solid particulates on the offline filter media will be cleared by backwashing or by chemical cleaning. The resulting particulates will be transferred via a hose-in-hose drain line to tank AP-108, the process return tank [RPP-RPT-61188, *Tank Side Cesium Removal (TSCR) and Spent Ion-Exchange Column Storage Pad Preliminary Documented Safety Analysis*].

⁴⁹ For example, the approximate half-life of ¹³⁷Cs is slightly longer than 30 years.

⁵⁰ Valving allows any of the three IX columns to be used in the lead, lag, and polish position sequencing.

Figure 4-2. Tank-Side Cesium Removal System.

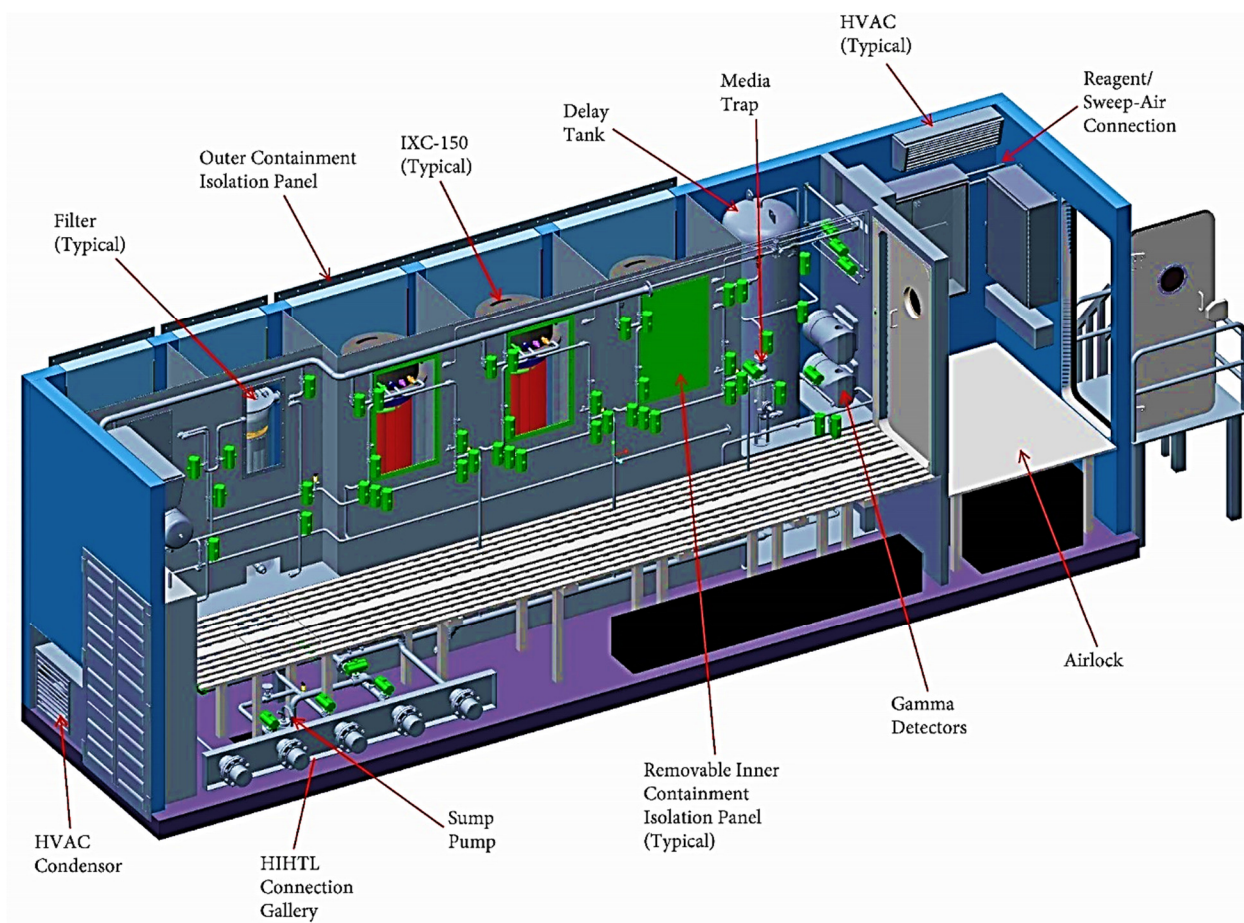

Source: *Tank Side Cesium Removal Demonstration Project*,
https://www.hanford.gov/files.cfm/HAB_TSCR_03-13-19-scs_AJZ.PDF

The average decontamination factor for ^{137}Cs was calculated by dividing the total amount of ^{137}Cs that will enter the lead IX column by the total amount of ^{137}Cs that will exit the polish IX column for each DFLAW campaign (Table 4-4). Similar to the average throughput, the decontamination factor is dependent on the concentration and diffusion coefficients of species involved in IX reactions, but is strongly dependent on the concentration of cesium in the feed to TSCR. Lower concentrations of cesium in the feed will result in lower decontamination factors because the feed concentrations are closer to the equilibrium concentration in the liquid phase, and a lower concentration of cesium in the feed means that less cesium has to be removed to meet the waste acceptance criteria.

**Table 4-4. Direct-Feed Low-Activity Waste Campaign Cesium
Decontamination Factors.**

| Direct-Feed Low-Activity Waste Campaign | Average Decontamination Factor |
|--|---------------------------------------|
| 1 | 10,313 |
| 2 | 8,270 |
| 3 | 10,427 |
| 4 | 9,897 |
| 5 | 7,798 |
| 6 | 7,355 |
| 7 | 6,019 |
| 8 | 8,740 |
| 9 | 5,145 |
| 10 | 6,956 |
| 11 | 7,062 |
| 12 | 10,867 |
| 13 | 9,828 |
| 14 | 3,162 |
| 15 | 3,752 |
| 16 | 1,843 |
| 17 | 2,478 |
| 18 | 6,335 |
| 19 | 5,743 |
| 20 | 4,131 |
| 21 | 5,040 |
| 22 | 5,141 |
| 23 | 5,723 |
| 24 | 3,228 |
| 25 | 3,509 |
| 26 | 3,225 |
| 27 | 2,898 |

Derived from RPP-CALC-63643, *Sum of Fractions Calculations for DFLAW Immobilized LAW Glass.*

4.2.2.6 Other Soluble Key Radionuclides

The other key soluble radionuclides are ^3H , ^{14}C , ^{60}Co , ^{59}Ni , ^{99}Tc , ^{129}I and potentially ^{90}Sr .⁵¹ Hydrogen-3 and Carbon-14 are not present in the vitrified LAW as they partition to solid secondary waste during the melting process. Cobalt-60 has a short half-life (approximately 5 years) and thus is not a contributor to dose after closure of IDF. Nickel-59, with a half-life of 1.01×10^5 years, is present in very low concentrations in the vitrified LAW and is an insignificant contributor to dose after IDF closure (see IDF PA Table 7-13)⁵².

With respect to ^{99}Tc , ^{129}I and soluble ^{90}Sr , the IDF PA shows that doses (within both the compliance and post-compliance periods, for base case and sensitivity analyses) from disposal of the vitrified LAW to a member of the public and a hypothetical human intruder (acute and chronic) are well below performance objectives and performance measures.

Furthermore, DOE has performed extensive studies on potential removal of technetium. Elutable IX with SuperLig[®] 639⁵³ was tested extensively in 1996 to 2003 for deployment in the original Hanford WTP. See RPP-PLAN-54676, *Technetium Removal Technology Development Plan for Elutable Ion Exchange*. However, because technetium will be retained by the vitrified waste form,⁵⁴ DOE and Ecology agreed to delete technetium removal implementation from the WTP permit [Letter 0078886, “Re: Draft Waste Treatment and Immobilization Plant (WTP) Dangerous Waste Permit”]. See 78 FR 75913, “Record of Decision: Final Tank Closure and Waste Management Environmental Impact Statement for the Hanford Site, Richland, Washington”.

DOE has also explored whether there is an available technology to remove ^{129}I . However, the ^{129}I concentration in the tank wastes is typically 1,000 to 10,000 times lower than would exist in commercial fuel dissolver solutions for which an available iodine removal technology was developed. Iodine-129 removal is not considered to be technically practical because no technology has been demonstrated for the relatively low concentrations in the Hanford Site tank waste (WHC-SD-WM-TI-699, *Technical Basis for Classification of Low-Activity Waste Fraction from Hanford Site Tanks*).

4.2.2.7 Resulting Key Radionuclide Removal

Settling, decanting and filtration as previously described will remove the majority of the insoluble radionuclides. These insoluble radionuclides contain nearly all the short-lived ^{90}Sr (and daughter ^{90}Y) and long-lived actinides (e.g., uranium, plutonium, americium, neptunium, and curium). Of the remaining radioactivity, approximately 94% is from ^{137}Cs and its daughter,

⁵¹ ^{90}Sr is primarily insoluble but can be soluble in some tanks with a higher organic concentration. Tanks with soluble ^{90}Sr are not currently planned to be part of the DFLAW campaigns but potentially may be added in the future. The IDF PA includes VLAW from tanks with soluble ^{90}Sr .

⁵² See footnote 46 of this Draft WIR Evaluation.

⁵³ SuperLig[®] is a registered trademark of IBC Advanced Technologies, Inc., American Fork, Utah.

⁵⁴ With respect to ^{99}Tc and ^{129}I , the LAW Vitrification Facility is designed to maximize the capture of these radionuclides in the vitrified waste form. The LAW Vitrification Facility offgas system is designed to recycle and/or capture that portion of volatile radionuclides (including ^{99}Tc and ^{129}I) which are not vitrified (see Section 2.5.3).

^{137m}Ba (derived from RPP-CALC-63643, *Sum of Fractions Calculations for DFLAW Immobilized LAW Glass*, Rev. 3, Table 7-6). Percentages of total curies and ¹³⁷Cs curies that will be removed by the TSCR operation for each DFLAW campaign are shown in Table 4-5 and Table 4-6, respectively. Information in these tables indicates the effectiveness of TSCR operation to pretreat LAW feed and to remove the bulk of ¹³⁷Cs (and its daughter) from the feed batches.

Table 4-5. Percentages of Total Curies Removed by Tank-Side Cesium Removal Operation.

| DFLAW Campaign | TSCR Feed (Ci) | Treated LAW (Ci) | % Ci Removed from TSCR Feed |
|----------------|----------------|------------------|-----------------------------|
| 1 | 1.03E+06 | 2.74E+03 | 99.73% |
| 2 | 9.15E+05 | 2.27E+04 | 97.53% |
| 3 | 1.16E+06 | 1.94E+04 | 98.33% |
| 4 | 1.14E+06 | 2.11E+04 | 98.14% |
| 5 | 7.76E+05 | 1.23E+04 | 98.41% |
| 6 | 7.31E+05 | 1.71E+04 | 97.67% |
| 7 | 7.49E+05 | 2.54E+04 | 96.61% |
| 8 | 8.83E+05 | 1.99E+04 | 97.74% |
| 9 | 7.45E+05 | 2.29E+04 | 96.93% |
| 10 | 8.37E+05 | 4.23E+04 | 94.95% |
| 11 | 7.98E+05 | 6.97E+04 | 91.27% |
| 12 | 1.35E+06 | 8.00E+04 | 94.06% |
| 13 | 1.02E+06 | 1.71E+04 | 98.32% |
| 14 | 3.10E+05 | 1.09E+04 | 96.50% |
| 15 | 4.86E+05 | 1.07E+04 | 97.81% |
| 16 | 2.41E+05 | 8.75E+03 | 96.37% |
| 17 | 2.78E+05 | 7.54E+03 | 97.29% |
| 18 | 7.27E+05 | 2.22E+04 | 96.95% |
| 19 | 6.86E+05 | 2.57E+04 | 96.25% |
| 20 | 5.19E+05 | 3.00E+04 | 94.22% |
| 21 | 6.43E+05 | 2.63E+04 | 95.91% |
| 22 | 6.24E+05 | 2.29E+04 | 96.33% |
| 23 | 7.09E+05 | 1.72E+04 | 97.57% |
| 24 | 3.52E+05 | 1.55E+04 | 95.59% |
| 25 | 3.43E+05 | 6.88E+03 | 98.00% |
| 26 | 3.36E+05 | 9.95E+03 | 97.04% |
| 27 | 1.20E+05 | 1.51E+04 | 87.43% |

Table 4-5. Percentages of Total Curies Removed by Tank-Side Cesium Removal Operation.

| DFLAW Campaign | TSCR Feed (Ci) | Treated LAW (Ci) | % Ci Removed from TSCR Feed |
|----------------|----------------|------------------|-----------------------------|
|----------------|----------------|------------------|-----------------------------|

DFLAW = direct-feed low-activity waste
 LAW = low-activity waste

TSCR = Tank-Side Cesium Removal

Table 4-6. Percentages of Cesium-137 Removed by Tank-Side Cesium Removal in Direct-Feed Low-Activity Waste Campaigns.

| DFLAW Campaign | ¹³⁷ Cs in TSCR Feed (Ci) | ¹³⁷ Cs in Treated LAW Feed (Ci) | % ¹³⁷ Cs Removed by TSCR |
|----------------|-------------------------------------|--|-------------------------------------|
| 1 | 5.28E+05 | 5.12E+01 | 99.99% |
| 2 | 4.59E+05 | 5.55E+01 | 99.99% |
| 3 | 5.86E+05 | 5.62E+01 | 99.99% |
| 4 | 5.74E+05 | 5.80E+01 | 99.99% |
| 5 | 3.93E+05 | 5.04E+01 | 99.99% |
| 6 | 3.67E+05 | 4.99E+01 | 99.99% |
| 7 | 3.72E+05 | 6.18E+01 | 99.98% |
| 8 | 4.44E+05 | 5.08E+01 | 99.99% |
| 9 | 3.72E+05 | 7.23E+01 | 99.98% |
| 10 | 4.09E+05 | 5.88E+01 | 99.99% |
| 11 | 3.75E+05 | 5.31E+01 | 99.99% |
| 12 | 6.52E+05 | 6.00E+01 | 99.99% |
| 13 | 5.15E+05 | 5.24E+01 | 99.99% |
| 14 | 1.54E+05 | 4.87E+01 | 99.97% |
| 15 | 2.45E+05 | 6.53E+01 | 99.97% |
| 16 | 1.20E+05 | 6.51E+01 | 99.95% |
| 17 | 1.39E+05 | 5.61E+01 | 99.96% |
| 18 | 3.63E+05 | 5.73E+01 | 99.98% |
| 19 | 3.40E+05 | 5.92E+01 | 99.98% |
| 20 | 2.52E+05 | 6.10E+01 | 99.98% |
| 21 | 3.17E+05 | 6.29E+01 | 99.98% |
| 22 | 3.09E+05 | 6.01E+01 | 99.98% |
| 23 | 3.56E+05 | 6.22E+01 | 99.98% |

Table 4-6. Percentages of Cesium-137 Removed by Tank-Side Cesium Removal in Direct-Feed Low-Activity Waste Campaigns.

| DFLAW Campaign | ¹³⁷ Cs in TSCR Feed (Ci) | ¹³⁷ Cs in Treated LAW Feed (Ci) | % ¹³⁷ Cs Removed by TSCR |
|----------------|-------------------------------------|--|-------------------------------------|
| 24 | 1.73E+05 | 5.36E+01 | 99.97% |
| 25 | 1.73E+05 | 4.93E+01 | 99.97% |
| 26 | 1.68E+05 | 5.21E+01 | 99.97% |
| 27 | 5.42E+04 | 1.87E+01 | 99.97% |

DFLAW = direct-feed low-activity waste
LAW = low-activity waste

TSCR = Tank-Side Cesium Removal

The IDF PA shows that the key radionuclides present in the vitrified LAW (⁹⁰Sr, ⁹⁹Tc, ¹²⁹I, ¹³⁷Cs, ²²⁸Rn, ²²⁹Th, ²³²Th, ²³⁴U, ²³⁸U, and ²³⁷Np) will present little risk to the public or human intruder. The IDF PA (see Section 5 of this Draft WIR Evaluation) shows that the dose (within both compliance and post-compliance periods, for base case and sensitivity analyses) attributable to disposal of the LAW vitrified glass to a member of the public and a hypothetical human intruder (acute and chronic) are well below the performance objectives and performance measures.

Thus, using a risk-informed approach, it is not useful or sensible to further remove key radionuclides from the VLAW waste stream. Therefore, key radionuclides will be removed to the maximum extent technically practical using the DFLAW approach.

4.2.3 Economic Practicality Assessment

The assessment of “economic practicality” contemplates consideration of benefits to worker and public health, safety, and the environment arising from further radionuclide removal, when compared to the cost (monetary costs as well as schedule delays, environmental, and human health and safety costs) of additional removal of key radionuclides. Economic practicality includes consideration of total lifecycle costs, the cost per curie removed, the relationship between costs and removal of the key radionuclides, and the point in this relationship at which removal costs increase significantly and thus become impractical (see DOE G 435.1-1). In this regard, removal of key radionuclides to the “maximum extent ...economically practical” includes consideration of expert judgment, and whether the benefits to health and safety outweigh the disadvantages. In essence, “economic practicality” focuses on whether further radionuclide removal would be useful and sensible in light of the overall benefit to human health, safety and the environment. The following paragraphs discuss DOE’s evaluations of economic practicality in chronological order.

DOE previously evaluated technology options to remove radionuclides from the Hanford tank wastes, which culminated in a Technical Basis Summary Report (WHC-SD-WM-TI-699) issued in 1996, hereafter referred to as the TBR. This TBR was reviewed by the NRC, which concluded that “...available separation processes have been extensively examined to determine

those that are both technically and economically practical...”, as discussed further in Appendix D.

The TBR described in-tank solid/liquid separation by settle/decant to remove insoluble radionuclides (mostly long-lived), and noted that, at the time: “Solid/liquid separation by in-tank settle/decant has been practiced in tank farm operations over the last 50 years” (TBR at page ES-iv). The TBR also evaluated technology options to remove cesium, strontium, transuranic (TRU) radionuclides, ⁹⁹Tc, ⁷⁹Se, ¹⁴C, ¹²⁹I, ³H, tin, and uranium from Hanford tank waste. The TBR evaluation consisted of: (1) identifying individual technology options for radionuclide separations processes, (2) identifying the status of the technology, (3) defining the radionuclide removal efficiency and (4) determining the cost of implementing the technology. The cost of implementing a given technology, with an estimated curie removal for the technology, was assessed in terms of cost per curie to provide a measure of economic practicality. An economic assessment was provided only if a technology was deemed technically practical.

Table 4-7 summarizes the costs for the technically practical radionuclide removal technology options identified in the TBR. The costs are provided in terms of cost information at the time and have not been adjusted to 2020 dollars.

Table 4-7. Summary of Costs for Technically Practical Radionuclide Removal Technology Options.

| Technically Practical Technology Option | Economically Practical | Cost \$/Ci |
|--|------------------------|------------|
| Single-Cycle Cation Ion Exchange, Selective Removal (¹³⁷ Cs concentration > 0.05 Ci/L) | Yes | 25 |
| Single-Cycle Cation Ion Exchange, Selective Removal (¹³⁷ Cs concentration < 0.05 Ci/L) | No | 65 |
| Single-Cycle Cation Ion Exchange | No | 30 |
| Second-Cycle Cation Ion Exchange | No | 420 |
| Hydroxide Precipitation for TRU and ⁹⁰ Sr, Selective Treatment | Yes | 63-128 |
| Ferric Hydroxide Precipitation for TRU and ⁹⁰ Sr, Selective Treatment | No | 140-570 |
| Solvent Extraction, TRUEX, PUREX | No | 800,000 |

Sources: *Report on DOE Hanford Tank Waste Classification*, Center for Nuclear Waste Regulatory Analyses (CNWRA), San Antonio, Texas, February 1997, and WHC-SD-WM-TI-699, *Technical Basis for Classification of Low-Activity Waste Fraction from Hanford Site Tanks*, Westinghouse Hanford Company.

PUREX = plutonium uranium extraction TRU = transuranic TRUEX = transuranic extraction (process)

In October 2017, DOE conducted an External Expert Review of the LAWPS [RPP-RPT-60405, *External Expert Review of the Low-Activity Waste Pretreatment System (LAWPS) Project*]. Consistent with the recommendations in this 2017 External Review, DOE decided to pursue the DFLAW approach (84 FR 424, pp. 425). As recommended in this External Review, the first

phase of the DFLAW approach will deploy a TSCR system utilizing CST.⁵⁵ As emphasized in the report, this approach will accelerate the tank waste pretreatment schedule, reduce project cost and deploy a mature demonstrated technology. In addition, the use of CST was matured by Oak Ridge National Laboratory and Savannah River National Laboratories, and demonstrated by treating 268,000 gallons of liquid waste from the Melton Valley storage tanks (ORNL/TM-2001/129, *Wastewater Triad Project: Final Summary Report*). The CST media also has been used internationally at the Fukushima Daiichi cleanup in Japan (Honeywell UOP, Queried 09/20/2018, [*Adsorbents for Nuclear Waste Remediation*]). Both spherical resorcinol-formaldehyde (sRF) and CST are capable of decontaminating tank waste to the same level of ¹³⁷Cs concentration (WSRC-STI-2007-00609, *Literature Reviews to Support Ion Exchange Technology Selection for Modular Salt Processing*).

The DFLAW approach, consistent with the External Review (RPP-RPT-60405), will: avoid schedule delays, save costs by creating additional DST tank space to support SST retrievals (thereby eliminating the need to build additional storage tanks), avoid returning ¹³⁷Cs or adding elution chemicals to the DST system, and align the pretreatment schedule to meet amended Tri-Party Agreement milestones. In addition, the facility total project cost for the DFLAW approach is expected to be significantly lower than the prior approach for LAWPS. Table 4-8 provides the comparison of economic practicality considerations between the prior approach for LAWPS and the TSCR approach.

Table 4-8. Comparison of DFLAW Pretreatment Approaches

| Economic Practicality Considerations | LAWPS Approach (Prior) | TSCR Approach |
|---|-------------------------------|----------------------|
| Settling to remove insoluble long-lived radionuclides > 50% | Yes | Yes |
| Separation of supernate by decanting | Yes | Yes |
| Filtration ¹ | Yes – Crossflow | Yes – Dead end |
| Cs removal > 99% | Yes – elutable | Yes – nonelutable |
| Meets LAW Vitrification throughput | Yes | Yes |
| Avoid cesium return to tank farm | No | Yes |
| Avoid adding elution chemicals to DSTs | No | Yes |
| Avoid project delay /support December 2021 target date for feed delivery to LAW Vitrification Facility | No | Yes |
| Meets Amended Consent Decree milestone for LAW Vitrification Facility hot commissioning (December 2023) | No | Yes |
| Frees DST space to support SST retrievals/avoid building new DSTs | No | Yes |

⁵⁵ During DFLAW, the liquid supernate and dissolvable saltcake from the campaign tanks are withdrawn independent of any settled solids in the tanks, followed by filtration using a Grade 5 Mott or finer sintered filter, followed by ¹³⁷Cs removal using IX resin to meet the waste feed acceptance criteria for the LAW Vitrification Facility.

Table 4-8. Comparison of DFLAW Pretreatment Approaches

| Economic Practicality Considerations | LAWPS Approach (Prior) | TSCR Approach |
|--|-------------------------------|------------------------|
| Meets CD-1 total project cost range ² | No – \$790M | Yes – \$220M to \$470M |
| Requires interim storage of spent media columns | No | Yes |

¹Differences in filtration methods between the two approaches is discussed further in Appendix F.

²Meets delivery of pretreatment within CD-1 cost range, as was approved per DOE O 413.3B, *Program and Project Management for the Acquisition of Capital Assets*.

Table Reference: Amended Consent Decree, *State of Washington v. Department of Energy*, Case No. 2:08-CV-08-5085-RMP, United States District Court, Eastern District of Washington (March 11, 2016).

DST = double-shell tank LAW = Low-Activity Waste (Facility) SST = single-shell tank
 DFLAW = Direct-Feed Low-Activity Waste LAWPS = Low-Activity Waste Pretreatment System

4.3 CONCLUSIONS ON KEY RADIONUCLIDE REMOVAL

The technical practicality assessment discussed in Section 4.2.2 shows that settling, separation (removal by decanting), filtration, and the use of CST IX under the DFLAW approach will remove key radionuclides to the maximum extent technically practical. For example, the DFLAW approach is expected to remove greater than 99% of the ¹³⁷Cs, the predominant short-lived radionuclide contributing to dose to the workers and the public. The economic practicality assessment discussed in Section 4.2.3 shows, among other things, that the DFLAW approach will result in significant monetary cost savings, avoid delays (including LAW Vitrification Facility startup and tank retrieval/closures), meet the Amended Consent Decree milestone for completion of LAW Facility hot commissioning, and create additional DST space to support SST retrievals (thereby eliminating the cost to build additional DSTs).

Accordingly, this Draft WIR Evaluation demonstrates that key radionuclides will be removed to the maximum extent technically and economically practical.

5.0 THE WASTE WILL BE MANAGED TO MEET SAFETY REQUIREMENTS COMPARABLE TO THE PERFORMANCE OBJECTIVES OF 10 CFR Part 61, SUBPART C

Section Purpose

The purpose of this section is to evaluate whether the VLAW will be managed to meet safety requirements comparable to the performance objectives of 10 CFR Part 61, Subpart C for disposal of low-level radioactive waste.

Key Point

Management (disposal) of the VLAW in the IDF will meet DOE safety requirements for low-level radioactive waste disposal, which are comparable to the 10 CFR Part 61, Subpart C performance objectives.

5.1 INTRODUCTION

The second criterion of Chapter II.B.2(a) of DOE M 435.1-1 is evaluated in this section. This criterion reads as follows:

“[The waste w]ill be managed to meet safety requirements comparable to the performance objectives set out in 10 CFR Part 61, Subpart C, *Performance Objectives*”.

This section addresses compliance with the second criterion of DOE M 435.1-1.

5.2 U.S. DEPARTMENT OF ENERGY SAFETY REQUIREMENTS

DOE has established requirements for management of radioactive waste to ensure protection of workers, the public, and the environment that comply with applicable Federal, State, and local laws and regulations. DOE has also established specific requirements for its radioactive waste disposal facilities, including the IDF. These requirements include:

- (1) Performance objectives set forth in Chapter IV of DOE M 435.1-1, which include maximum dose limits;
- (2) DOE regulations at 10 CFR Part 835, “Occupational Radiation Protection” and DOE O 458.1, *Radiation Protection of the Public and the Environment*,⁵⁶ cross referenced in Chapters I and IV of DOE M 435.1-1;

⁵⁶ DOE O 458.1, Chg. 3 (hereinafter DOE O 458.1) cancelled and superseded DOE O 5400.5 of the same name, which is cross-referenced in DOE M 435.1-1.

- (3) Waste acceptance requirements that include establishing limits on radionuclides that may be disposed of based on a performance assessment of the facility;
- (4) Performance assessment⁵⁷ of the disposal facility that provides reasonable expectation that DOE's performance objectives will not be exceeded;
- (5) Composite analysis that considers other radioactivity sources in the area as well as the disposal facility;
- (6) Performance assessment and composite analysis maintenance plan;
- (7) Preliminary closure plan; and
- (8) Monitoring plan (DOE M 435.1-1).

For wastes to be disposed of at DOE facilities, DOE establishes waste acceptance criteria, based upon an independently reviewed and accepted PA, which also includes provisions for maintenance and updating. Acceptability of the PA is verified against the performance objectives of Chapter IV.P. of DOE M 435.1-1, as well as other requirements in DOE M 435.1-1, through an independent review by the Low-Level Waste Disposal Facility Federal Review Group (LFRG). This review serves as the basis for DOE to issue a Disposal Authorization Statement, which specifies any additional conditions that the site may need to impose to ensure that the performance objectives of DOE M 435.1-1, Chapter IV.P.(1) are met.

Figure 5-1 illustrates the general process used to provide reasonable expectation⁵⁸ that disposal site performance objectives are achieved.

The following subsections address the specific DOE performance objectives and measures for DOE LLW disposal sites, as well as relevant DOE regulations and orders. These performance objectives, regulations, and Orders are set forth or cross referenced in DOE M 435.1-1, and, as discussed in Appendix A, provide safety requirements comparable to the NRC performance objectives of 10 CFR Part 61, Subpart C. As shown in Appendix B, the DOE and NRC dose standards are comparable.

⁵⁷ Generally, a performance assessment is a multi-disciplined assessment (e.g., geochemistry, hydrology, materials science, and health physics) which uses a variety of computational modeling codes to evaluate groundwater concentrations and doses at various points of assessment over time. In doing this assessment, DOE evaluates the impact of natural features (e.g., hydrology, soil properties, groundwater infiltration), waste forms and engineered barriers (e.g., closure cap, waste facility design) on the release of radionuclides, to estimate, among other things, the potential dose to a hypothetical member of the public and a hypothetical inadvertent intruder. The results of the IDF PA, as reported here, should not be considered limits or thresholds. As required by DOE M 435.1-1, maintenance of the IDF PA will include future performance assessment revisions or special analyses to incorporate new information, update model codes and reflect analysis of actual inventories.

⁵⁸ DOE M 435.1-1 uses the phrase "reasonable expectation," which is analogous to "reasonable assurance" used in 10 CFR Part 61, Subpart C. This Draft WIR Evaluation uses the phrase "reasonable expectation," except when quoting directly from NRC regulations at 10 CFR Part 61, Subpart C.

Figure 5-1. General Process Used to Ensure Performance Objectives Are Achieved.

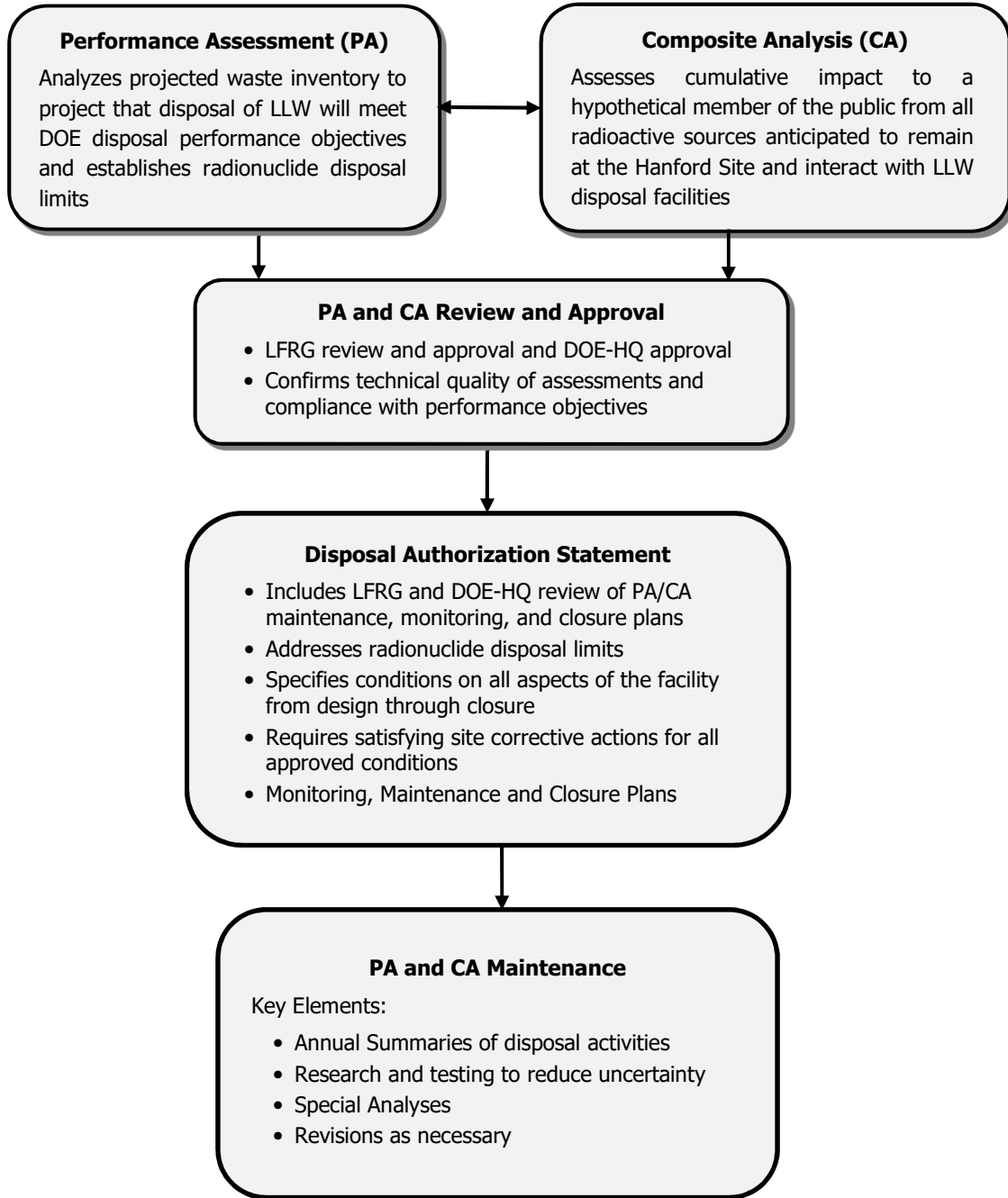

DOE = U.S. Department of Energy

DOE-HQ = U.S. Department of Energy-Headquarters

LFRG = Low-Level Waste Disposal Facility Federal Review Group

LLW = low-level waste

5.2.1 General Safety Requirement

The general requirement in DOE M 435.1-1, Chapter IV.P.(1), which is comparable to the requirement at 10 CFR 61.40, “General requirement” as shown in Appendix A, is expressed as follows:

“Low-level waste disposal facilities shall be sited, designed, operated, maintained, and closed so that a reasonable expectation exists that the following performance objectives⁵⁹ will be met for waste disposed of after September 26, 1988.”

As with other DOE LLW disposal facility PAs, the IDF PA (RPP-RPT-59958) involved detailed analyses of potential radiation doses to those who may be affected in future years to ensure that when the facility is closed, it will continue to meet the performance objectives. These performance objectives include dose limits for a member of the public and performance measures for a hypothetical person who, unaware of the buried radioactivity, might drill a well into the buried waste and subsequently establish a farm on the site, referred to as the inadvertent intruder scenario. As analyzed in the IDF PA, the inadvertent intruder scenarios evaluate the acute impact via the well driller scenario and the chronic impact via the rural pasture scenario. Both scenarios are based on individuals exposed to the exhumed waste under postulated exposure conditions as described in Table 5-1.

Table 5-1. Integrated Disposal Facility Performance Assessment Acute and Chronic Inadvertent Intruder Scenarios.

| Scenario | Description |
|-----------------------|--|
| Acute Well Driller | The acute well driller scenario evaluates the short-term exposure of a well driller to drill cuttings that are exhumed from a well that is installed to the depth of the water table for the supply of water. As the well is drilled through the waste residuals, the driller will be exposed to the radiation dose from the drill cuttings. The well driller is assumed to be exposed to drill cuttings for a total of five days (8 hours per day for a total of 40 hours). The dose is calculated assuming that the cuttings are uniformly spread across the drill pad, and the pad is small enough that concentrations are not diluted by mixing with clean soil. |
| Chronic Rural Pasture | The chronic rural pasture scenario evaluates the long-term exposure to an individual that uses the target field as a residence with a pasture used for milk production from dairy cows. In this scenario, a well is drilled and the drill cuttings are spread over a pasture area of 5,000 m ² , and the cuttings are tilled to a depth of 15 cm. This scenario represents an individual that resides and has a pasture on the target field area. |

Source: RPP-CALC-61254, *Inadvertent Intruder Dose Calculation Update for the Integrated Disposal Facility Performance Assessment*.

The relevant DOE performance objectives and measures are addressed in Section 5.2.2 through Section 5.2.5.

⁵⁹ Each of these performance objectives is identified and discussed below.

5.2.2 Protection of the General Population from Releases of Radioactivity

The DOE requirements in DOE M 435.1-1, Chapter IV.P.(1), read as follows:

- “(a) Dose to representative members of the public shall not exceed 25 mrem (0.25 mSv) in a year total effective dose equivalent from all exposure pathways, excluding the dose from radon and its progeny in air.
- (b) Dose to representative members of the public via the air pathway shall not exceed 10 mrem (0.10 mSv) in a year total effective dose equivalent, excluding the dose from radon and its progeny.
- (c) Release of radon shall be less than an average flux of 20 pCi/m²/s (0.74 Bq/m²/s) at the surface of the disposal facility. Alternatively, a limit of 0.5 pCi/l (0.0185 Bq/l) of air may be applied at the boundary of the facility.”

These requirements are comparable to the requirements at 10 CFR 61.41, “Protection of the general population from releases of radioactivity”, although DOE’s dose limit uses more current radiation dosimetry methodology. The comparison and an explanation of these differences are described in Appendix A.

5.2.2.1 Assessment of Integrated Disposal Facility Performance

The IDF PA provides reasonable expectation that the performance objective for protection of the general population from radioactivity will be met during the 1,000-year post-closure period of compliance.

The IDF PA provides conservative and bounding analyses, which includes the VLAW generated by the DFLAW approach as well as other LAW and other MLLW.⁶⁰ The IDF PA results discussed below include these other wastes.

The IDF PA made use of two basic models, conceptual and mathematical.

Conceptual models describe all of the relevant properties of the IDF. A key property is the estimated radionuclide inventory at the time of facility closure, which was assumed to be 2051. This estimated inventory includes the complete inventory of VLAW along with other LLW and MLLW planned for disposal in the facility. Any additional waste streams different from those that were included in the IDF PA that are identified in the future would be evaluated per Special Analyses.⁶¹

⁶⁰ The IDF PA evaluates the disposal from vitrifying all LAW which produces about 130,000 containers, but DFLAW only produces about 13,500 containers.

⁶¹ “The primary role of the SA [is] to evaluate through modeling or other technical evaluation methods the impact of a proposed activity, discovery, or new information to the input and assumptions or results in the PA..., or to supplement or amend the analyses performed in the original PA...” (DOE-STD-5002-2017, *DOE Standard Disposal Authorization Statement and Tank Closure Documentation*).

Mathematical modeling is used with the conceptual model to calculate potential doses under different scenarios. The computer simulations solve coupled conservation equations for component mass that describe waste form releases and subsurface flow through variably saturated geologic media. The resulting flow fields are used to sequentially solve conservation equations for solute transport with radioactive chain decay through the variably saturated geologic media. These conservation equations are partial differential equations that mathematically describe flow and transport through porous media. The IDF PA uses the following.

- A two-dimensional, finite difference model solving the water mass conservation equation using Darcy's Law to simulate water flow through the engineered surface barrier into the facility, through the waste disposal zone, and out of the bottom of the facility into the vadose zone beneath the facility.
- A two-dimensional, finite difference, reactive transport model to simulate kinetic dissolution of the VLAW glass form using a transition-state-theory dissolution model with subsequent radionuclide release and transport by advection and diffusion to the bottom of the disposal facility.
- A three-dimensional, finite difference, advection and diffusion transport model solving the Richard's equation and advection-dispersion equation to simulate radionuclide release from cementitious waste forms and subsequent transport to the bottom of the disposal facility. Simulations for solidified waste in drums and carbon steel disposal boxes were performed, as were simulations for encapsulated waste in carbon steel disposal boxes.
- A three-dimensional, finite difference, advection and diffusion transport model solving the Richard's equation and advection-dispersion equation to simulate radionuclide transport from the bottom of the facility through the unsaturated vadose zone down to the water table with subsequent transport through the groundwater to a specified point of compliance.
- A one-dimensional, mass transfer model for diffusive releases from the waste form to the surface of the facility with subsequent transport through the air to a specified point of compliance calculated using a site-specific annual sector-average atmospheric dispersion coefficient (χ/Q).
- Unit dose conversion factors based on site-specific exposure parameters and DOE-approved dose conversion factors to convert calculated concentrations in the air and groundwater into doses.
- An integrated system model that includes abstractions developed from the two- and three-dimensional finite difference models was also used to evaluate parameter sensitivity and parameter uncertainty.

The IDF PA defined and analyzed both a base case and a collection of sensitivity and uncertainty cases. The base case is a single deterministic evaluation of the potential future dose to a

representative individual of the public that may result from the disposal of wastes at the IDF. It represents the scenario in which the safety functions behave as expected as the facility evolves into the future. The base case assumptions and parameters are based on the best-estimate representation of the available information, including available laboratory and in situ observations, though some parameter estimates related to future conditions may have a conservative bias. Model parameters are inherently uncertain and considerable effort has been expended to develop and evaluate parameter uncertainty. Using best-estimate values (i.e., the mean or median of a developed uncertainty distribution) rather than extreme values of an uncertainty distribution informs decision-making using likely outcomes rather than unlikely outcomes. The IDF PA also includes various uncertainty and sensitivity analyses to help place the best estimates into perspective.

As stated previously, the IDF PA provides reasonable expectation that the facility will not exceed the performance objectives during the compliance period of 1,000 years following closure of the facility. Facility closure is assumed to be in calendar year 2051. The IDF PA also includes a post-compliance period that extends the analysis from 1,000 to 10,000 years. The post-compliance analysis period is intended to provide information to decision-makers about potential long-term doses and exceedances of standards beyond the compliance period. The results for the compliance period of 1,000 years post-closure from the base case analysis show the following:

- An average ^{222}Rn flux of 0.016 pCi/m²/s at the surface of the disposal facility compared to the limit of 20 pCi/m²/s (Figure 5-2);
- An estimated annual all-pathways dose to a member of the public under the Representative Person scenario of 0.19 mrem, compared to the 25 mrem/yr limit (shown in figure as horizontal dotted red line) during the 1,000-year compliance period (Figure 5-3); and
- An estimated 0.19 mrem annual dose to representative members of the public via the air pathway (Figure 5-3), excluding the dose from radon and its progeny in air, compared to the 10 mrem/yr limit (limit is not shown in Figure 5-3).

The greatest impact to the representative individual through exposure via the air pathway occurs soon after the assumed end of the institutional control period. Due to dispersion, dose to the closest offsite receptor (20 km) during the institutional control period is much lower than the dose to a future receptor that resides 100 m downwind from the facility after the loss of institutional controls. In the IDF PA, institutional controls are assumed to be lost as early as 100 years after closure so that the greatest impact through the air pathway occurs when institutional controls are assumed to be lost and the member of the public resides 100 m from the IDF instead of 20 km from the IDF. Extended durations of institutional controls will not result in a significant decrease in the peak air pathway dose because the dominant contributors are long-lived radionuclides that will not decay significantly during the period of extended institutional controls. During the 1,000-year compliance period there is no impact to groundwater because travel times from the bottom of the facility to the water table exceed

1,000 years for non-sorbing contaminants. The long travel times are largely due to the low saturation and low annual recharge expected in the vadose zone beneath the facility.

Figure 5-2. Radon-222 Flux vs. Time After Integrated Disposal Facility Closure.

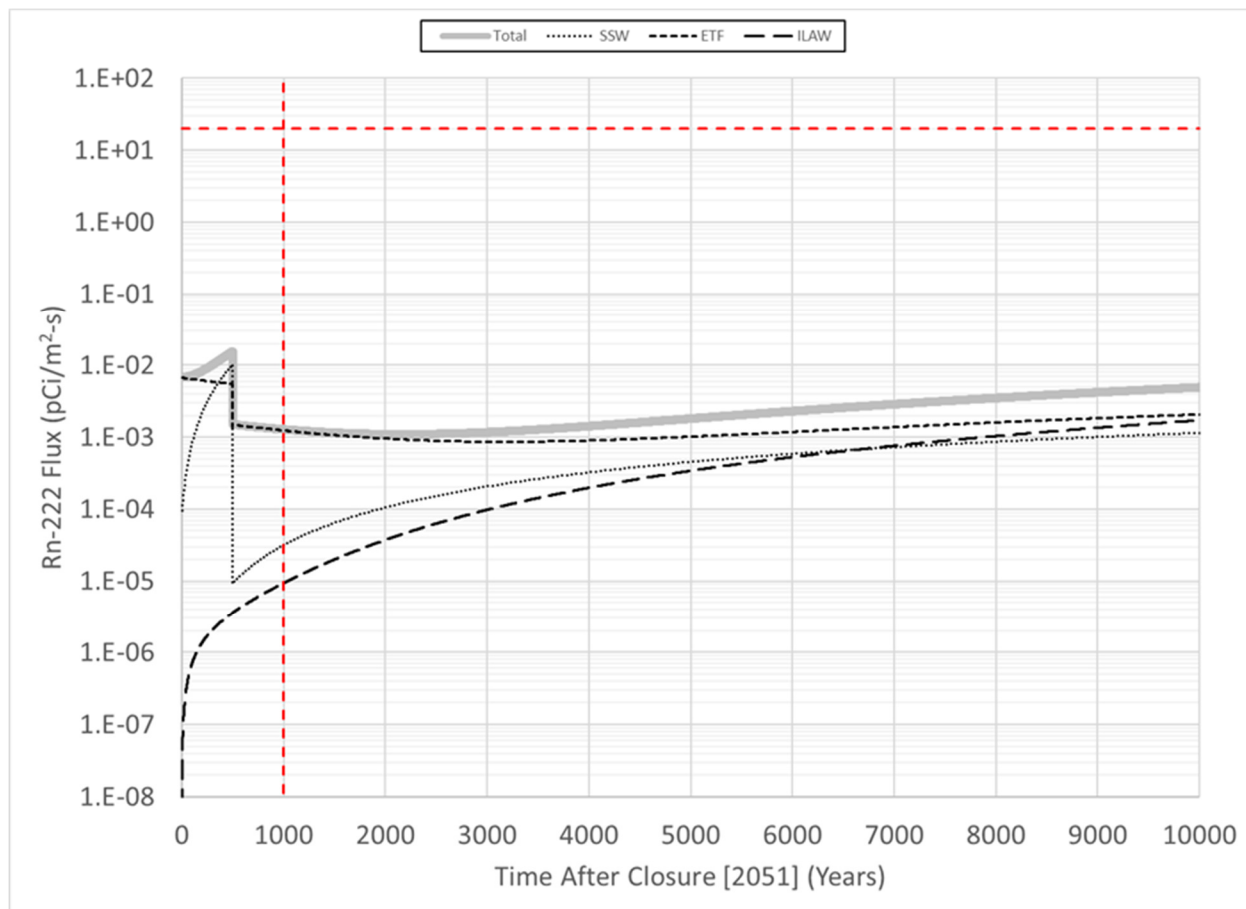

ETF = Effluent Treatment Facility ILAW = immobilized low-activity waste SSW = secondary solid waste

After the period of compliance, the impacts to the representative individual through the all-pathways exposure route are dominated by the groundwater pathway (Figure 5-3). The vertical dashed red line is the end of the 1,000-year compliance period; the horizontal dashed red line is the regulatory limit. The peak annual dose from the use of contaminated groundwater 100 m from the disposal facility occurs approximately 3,500 years after closure and is 1.5 mrem/yr.⁶² Figure 5-4 identifies the isotopic contribution to the groundwater pathway dose.

To build confidence in the modeled results, deterministic and probabilistic sensitivity and uncertainty analysis was performed. The mean annual dose was evaluated by performing calculations using four cases with increasing numbers of realizations (100, 200, 300, and 500).

⁶² The primary contributors to the peak dose after the 1,000-year compliance period are ⁹⁹Tc and ¹²⁹I in the HEPA filters and carbon bed adsorbers, respectively, and not from the VLAW which is addressed by this Draft WIR Evaluation. The IDF PA models include radionuclides from HEPA filters and carbon bed adsorbers, as well as waste from other WTP facilities, and therefore are bounding for the DLFAW approach.

The results showed that the mean and 50th percentile values derived from these four cases were very similar. Based on these results, it was concluded that 300 realizations as shown in Figure 5-5 are adequate for performing uncertainty analysis. Note that the red dashed lines indicate the 1,000-year compliance period and 25 mrem/yr dose limit. Figure 5-6 shows the total groundwater pathway dose computed in the uncertainty analysis. The median, 75th-percentile, 95th-percentile, and maximum doses at 1,000 years are 0.0, 0.0, 5×10^{-2} , and 2.1×10^{-2} mrem/yr, respectively. The median, 75th-percentile, 95th-percentile, and maximum peak doses between 1,000 and 10,000 years are 1.3, 2.3, 7.2, and 19.6 mrem/yr, respectively. The variability in the peak dose rate is due to ⁹⁹Tc releases from the vitrified LAW. Uncertainty in the vitrified waste corrosion rate parameters causes the vitrified waste corrosion rate to vary by one order of magnitude above and below the deterministic rate used to access compliance with DOE requirements. Changes in the peak groundwater pathway doses from the vitrified LAW are directly proportional to the changes in the corrosion rate. There is less uncertainty applied to the parameters that control releases of key radionuclides from secondary solid waste (SSW).⁶³ Therefore, uncertainty in the VLAW glass corrosion rate parameters tend to have a stronger correlation to the magnitude of the peak dose in 10,000 years. The uncertainty in the travel times of key radionuclides through the vadose zone to the groundwater is illustrated in Figure 5-6 by the different times that the groundwater dose crosses above the minimum y-axis value. The variability in this metric is controlled by the uncertainties in the net infiltration rate and sorption parameters for the sediments below the IDF. Figure 5-7 shows the mean groundwater pathway dose from the different waste streams simulated in the PA. The mean dose from vitrified LAW and SSW are similar and much greater than the mean dose from treated secondary liquid waste. The mean doses from vitrified LAW are similar to the SSW mean dose despite the two order of magnitude range in glass corrosion rates.

Intruder results provided in Figures 5-6 and 5-7 are discussed further in Section 5.2.4. The doses shown in Figures 5-6 and 5-7 start at the earliest time assumed for a loss of institutional controls (100 years after closure). The reported doses are the chronic and acute doses when an intrusion occurs in the year shown on the time axis. The dose histories shown in Figure 5-8 and Figure 5-9 illustrate the importance of half-lives and inventories on dose consequences following an inadvertent intrusion into the waste. Radionuclides with high inventories and high dose consequences but short half-lives, e.g., ¹³⁷Cs and ⁹⁰Sr, control doses caused by early intrusions into the waste. Due to radionuclide decay of these short-lived, high dose consequence radionuclides, dose consequences drop rapidly when the intrusion is delayed in time. The difference in inventories of short- and long-lived radionuclides between VLAW, SSW and ETF causes the dose differences between each waste stream. Compared to vitrified LAW, SSW has a greater drop in dose between 130 and 400 years and a lower dose at 1,000 years. This occurs because SSW has a greater concentration of short-lived radionuclides with high dose consequences (¹³⁷Cs and ⁹⁰Sr) and a lower concentration of long-lived radionuclides with high dose consequences (e.g., ⁹⁹Tc). Due to radionuclide decay of ¹³⁷Cs and ⁹⁰Sr, extending institutional controls later into the future lowers the calculated doses following the hypothetical intrusion. Simulations to 10,000 years reveal that dose from decay products will not cause a

⁶³ Secondary solid wastes are radioactive solid waste derived from WTP operations and will include a wide variety of wastes from routine maintenance activities, non-routine maintenance activities, and day-to-day operating activities (24590-WTP-PL-PENG-14-0006, *Secondary Wastes Compliance Plan*). SSW is not within the scope of this Draft WIR Evaluation and is discussed for completeness and additional information only.

dose consequence that exceeds the dose from radionuclides with longer half-lives, higher inventories, and greater dose consequences. Therefore, the dose in a 10,000-year evaluation achieves its peak as soon as the intrusion occurs. Because the intrusion is assumed to occur at the earliest loss of institutional controls, this is the point when the dose consequence following an inadvertent intrusion achieves its peak value.

Figure 5-3. All-Pathways Dose vs. Time After Integrated Disposal Facility Closure.

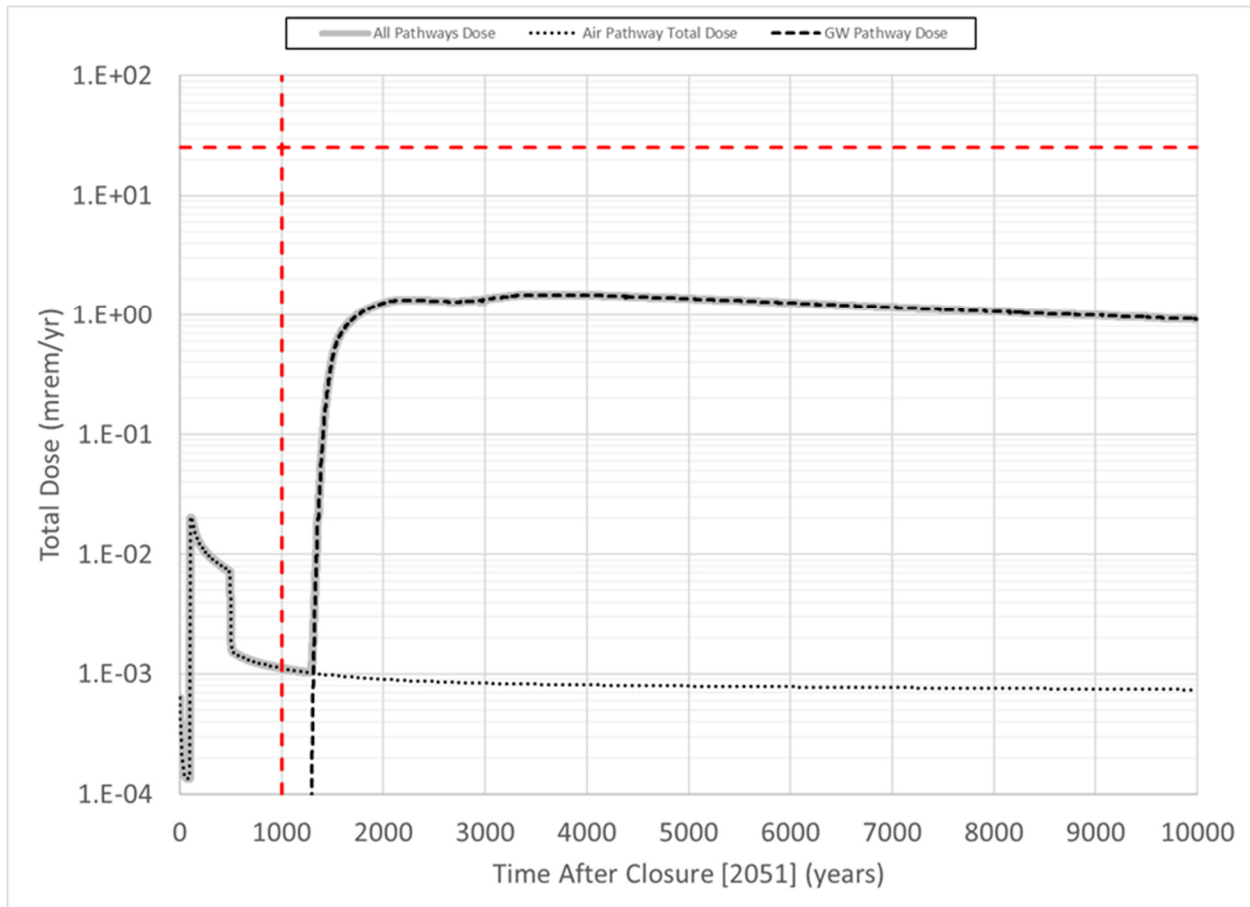

5.2.3 Estimated Impact of Disposal at Integrated Disposal Facility

The IDF PA results (base case) demonstrate that the estimated impact of VLAW disposal at the IDF will meet all DOE performance objectives during the compliance period of 1,000 years following closure. After the compliance time frame, the peak dose during the next 9,000 years is still below the performance objectives for the dose to a representative member of the public.

The IDF PA results demonstrate that the only impact from radioactive waste disposal during the period of compliance in DOE M 435.1-1 (1,000 years after closure) is through the air pathway. Due to the low recharge rates anticipated at the site over the next 1,000 years together with the depth to the water table, constituents of potential concern (COPC) released from the disposed waste do not reach the groundwater during the time of compliance.

Within the period of compliance, the radionuclides that can migrate to the surface by gaseous diffusion include ^{222}Rn , ^3H , ^{14}C , and ^{129}I [conservatively assumed to be $\text{I}_2(\text{g})$]. Immediately following closure of the facility, the waste packages are no longer assumed to be airtight and dose to the receptor from ^3H reaches a peak value (8.8×10^{-4} mrem/yr). However, the closest receptor is 20 km away and results in a lower dose than is observed from ^{14}C and ^{129}I , whose release from the waste forms is slower than ^3H , when the receptor is assumed to reside 100 m from the facility after the assumed loss of institutional controls. After an assumed loss of institutional controls (as early as 100 years after closure) the simulated dose from the air pathway peaks at 0.19 mrem/yr and rapidly declines to 0.01 mrem/yr, well below the 10 mrem/yr performance objective. The initial dose at the time of closure is attributed to ^3H from non-glass waste forms that is instantaneously released from the waste containers that are not assumed to be airtight after being buried in the facility. However, with institutional controls in place, the closest offsite receptor is 20 km from the facility, resulting in a low dose to the receptor. Within two years, the ^3H is dispersed and the 0.19 mrem/yr dose is attributed to ^{129}I from non-glass waste forms for a receptor that moves 100 m from the facility after the assumed loss of institutional control. Dose contributions from VLAW sources are less than 0.01% of the reported peak dose and less than 2% of the dose at other times during the period of compliance. Radon fluxes across the surface of the facility are more than three orders of magnitude below the performance objective of 20 pCi/m²/s.

Figure 5-4. Groundwater Pathway Dose by Isotope.

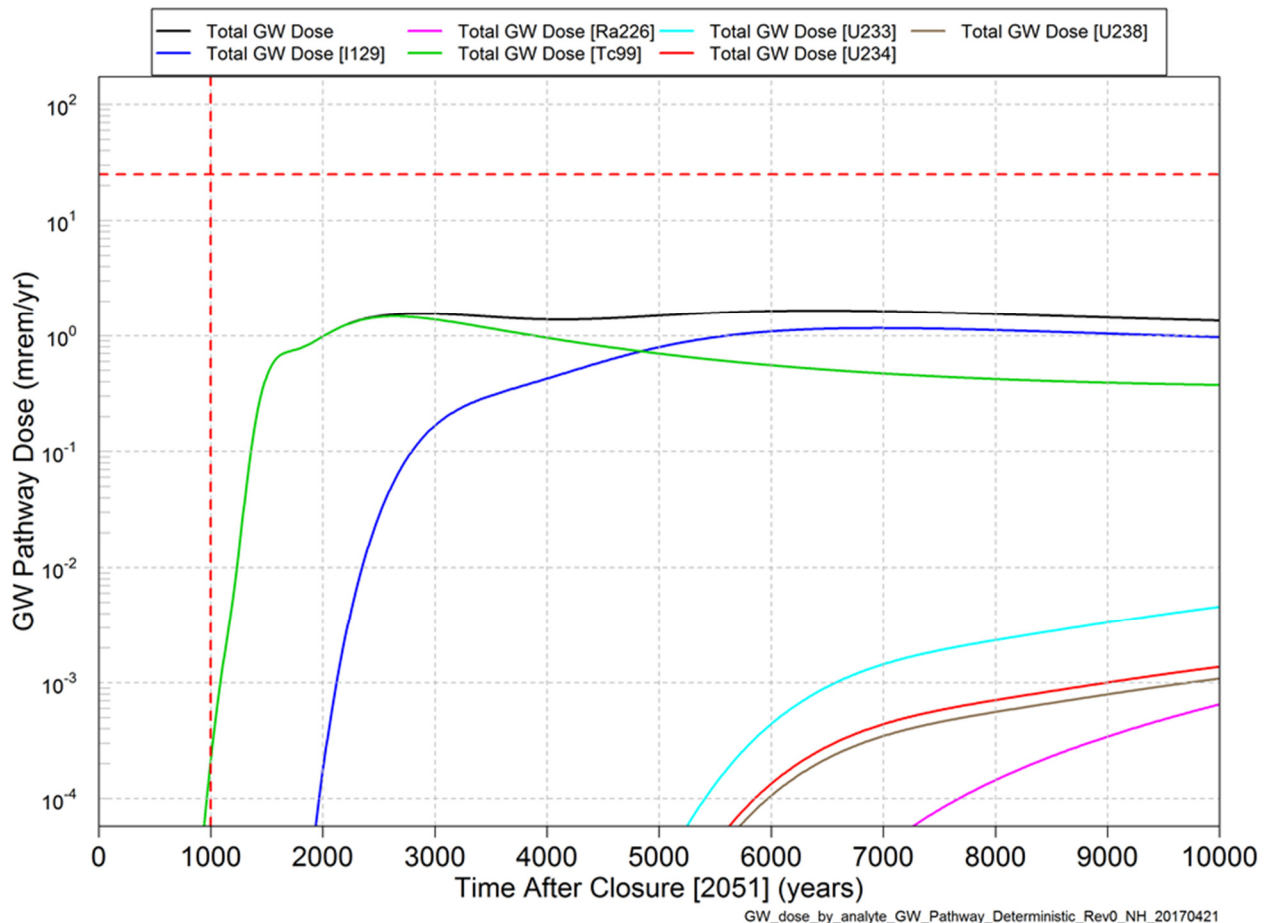
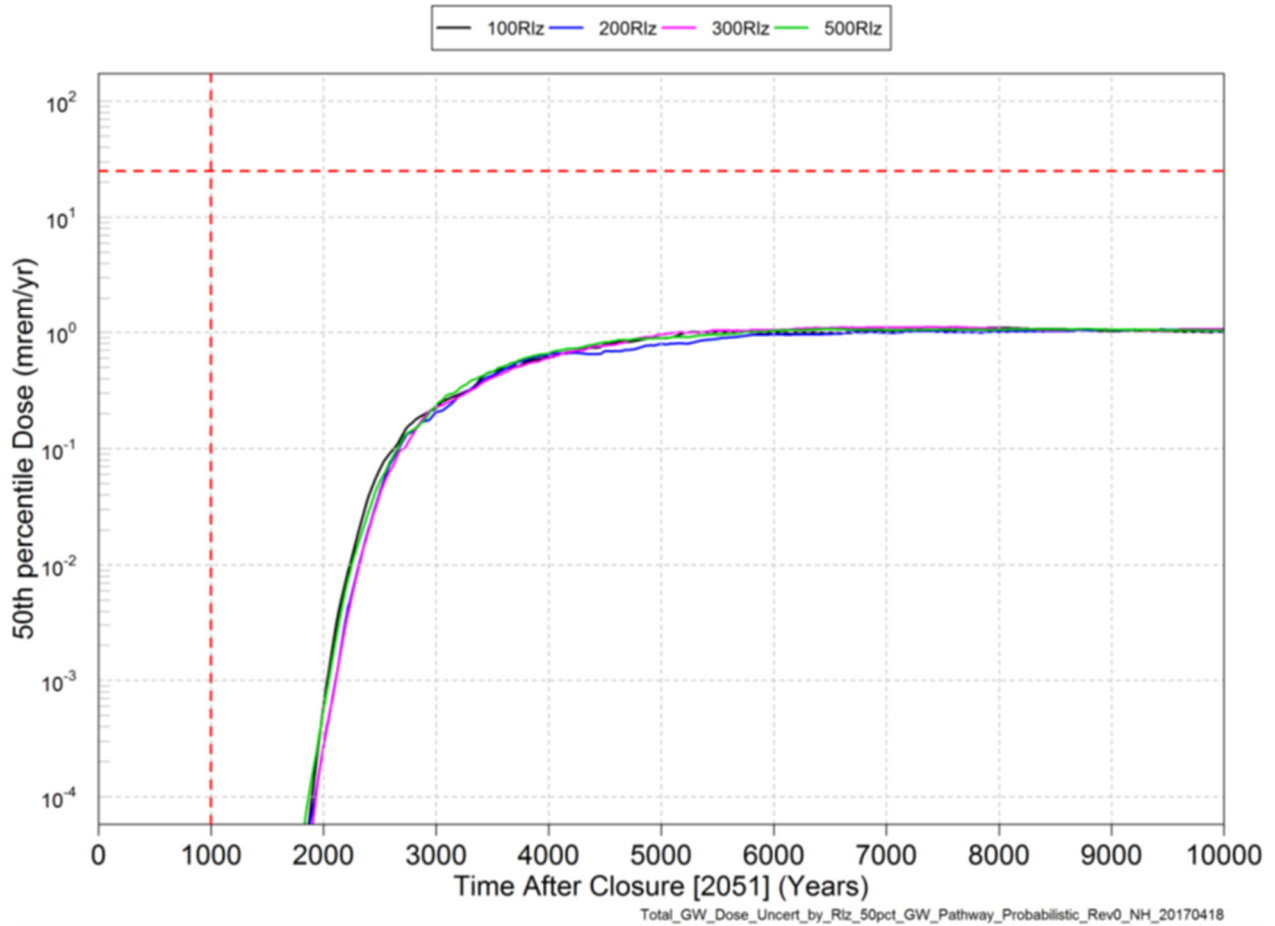
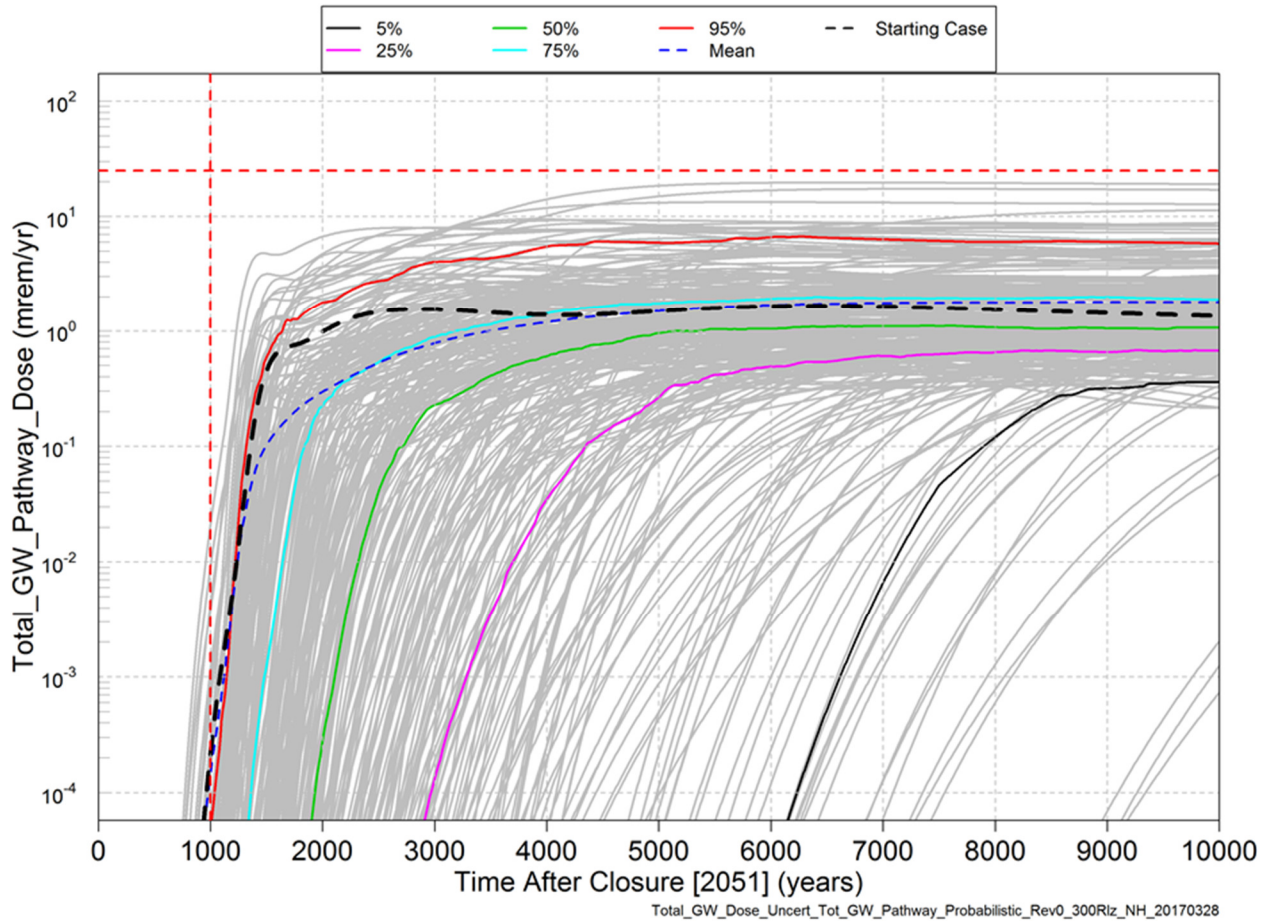

Figure 5-5. Statistical Stability Analysis – Comparison of Realizations to the Mean and 50th Percentile Groundwater Pathway Dose.



The presence of non-volatile radionuclides in the buried waste such as ²²⁹Th, ²⁴²Cm, ²⁴²Pu, ²⁴³Am-²⁴³Cm, and ²⁴⁴Cm was considered in the IDF PA in VLAW. The presence of these radionuclides in WTP-generated SSWs was excluded for the groundwater pathway. Regardless of their release rate from the SSW waste forms, sorption of these radionuclides in the vadose zone prevents these radionuclides from reaching the groundwater in 10,000 years. PA analyses show that travel times through the vadose zone sediments are at least 10,000 years for species with sorption coefficients greater than 3 mL/g. Thorium, curium, americium, and plutonium have sorption coefficients between 40 and 350 mL/g in natural and chemically-impacted vadose zone sand. Due to their high sorption coefficients (K_d) in the vadose zone, these radionuclides would not reach groundwater within 10,000 years and therefore are not risk significant.

Figure 5-6. Uncertainty Analysis – Comparison of Realizations for the Groundwater Pathway Dose.



For additional information, consideration has also been given to the potential impact of other site radioactivity sources on IDF performance relative to the predicted all-pathways dose. The 2016 site annual report on the composite analysis (CA) for LLW disposal in the Central Plateau [DOE/RL-2016-62, *Annual Status Report (FY 2016): Composite Analysis for Low Level Waste Disposal in the Central Plateau of the Hanford Site*]⁶⁴ shows that radioactive contamination from other sources in the Central Plateau does not impact predicted IDF performance. The migration time from the IDF to the water table is greater than 1,000 years due to the thick vadose zone and low recharge rates under the IDF surface barrier. Therefore, releases from the IDF will not reach the groundwater in the 1,000-year compliance period and will not co-mingle with other source plumes until at least 2,000 years after IDF closure.

⁶⁴ Information about this CA is included to further inform the reader. DOE has prepared the CA under DOE M 435.1-1, which accompanies DOE O 435.1, *Radioactive Waste Management*, pursuant to DOE's responsibilities under the AEA, as amended. The CA is not a WIR requirement, and is not relied upon in this Draft WIR Evaluation to demonstrate compliance with the WIR criteria.

Figure 5-7. Uncertainty Analysis – Comparison of Mean Annual Groundwater Pathway for Different Waste Streams.

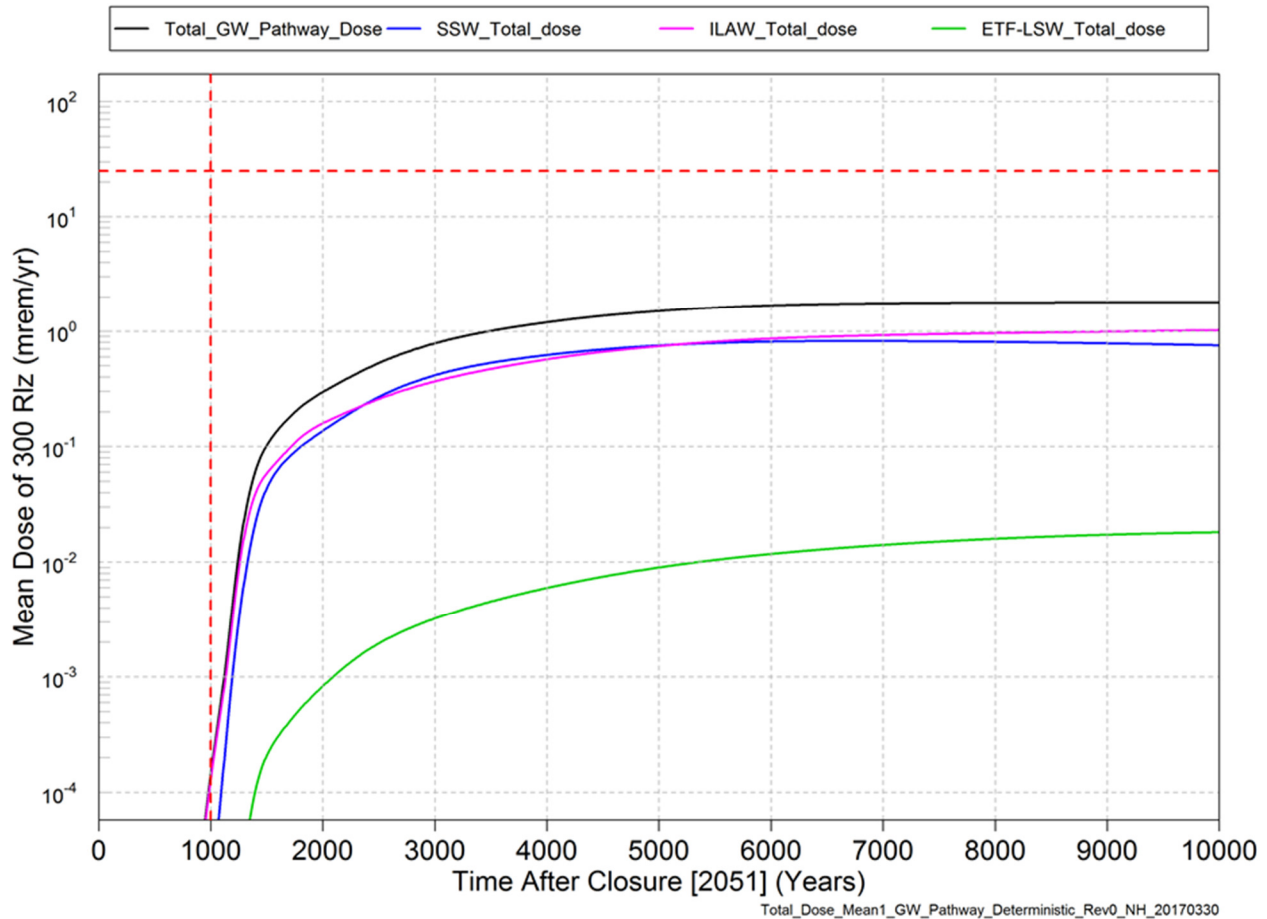

5.2.4 Protection of Individuals from Inadvertent Intrusion

The DOE requirements of DOE M 435.1-1, Chapter IV.P.(2)(h), for protection of individuals from inadvertent intrusion read as follows:

“For purposes of establishing limits on the concentration of radionuclides that may be disposed of near-surface, the performance assessment shall include an assessment of impacts calculated for a hypothetical person assumed to inadvertently intrude for a temporary period into the low-level waste disposal facility. For intruder analyses, institutional controls shall be assumed to be effective in deterring intrusion for at least 100 years following closure. The intruder analyses shall use performance measures for chronic and acute exposure scenarios, respectively, of 100 mrem (1 mSv) in a year and 500 mrem (5 mSv) total effective dose equivalent excluding radon in air.”

Figure 5-8. Well Driller Dose vs. Time After First Receipt at Integrated Disposal Facility.

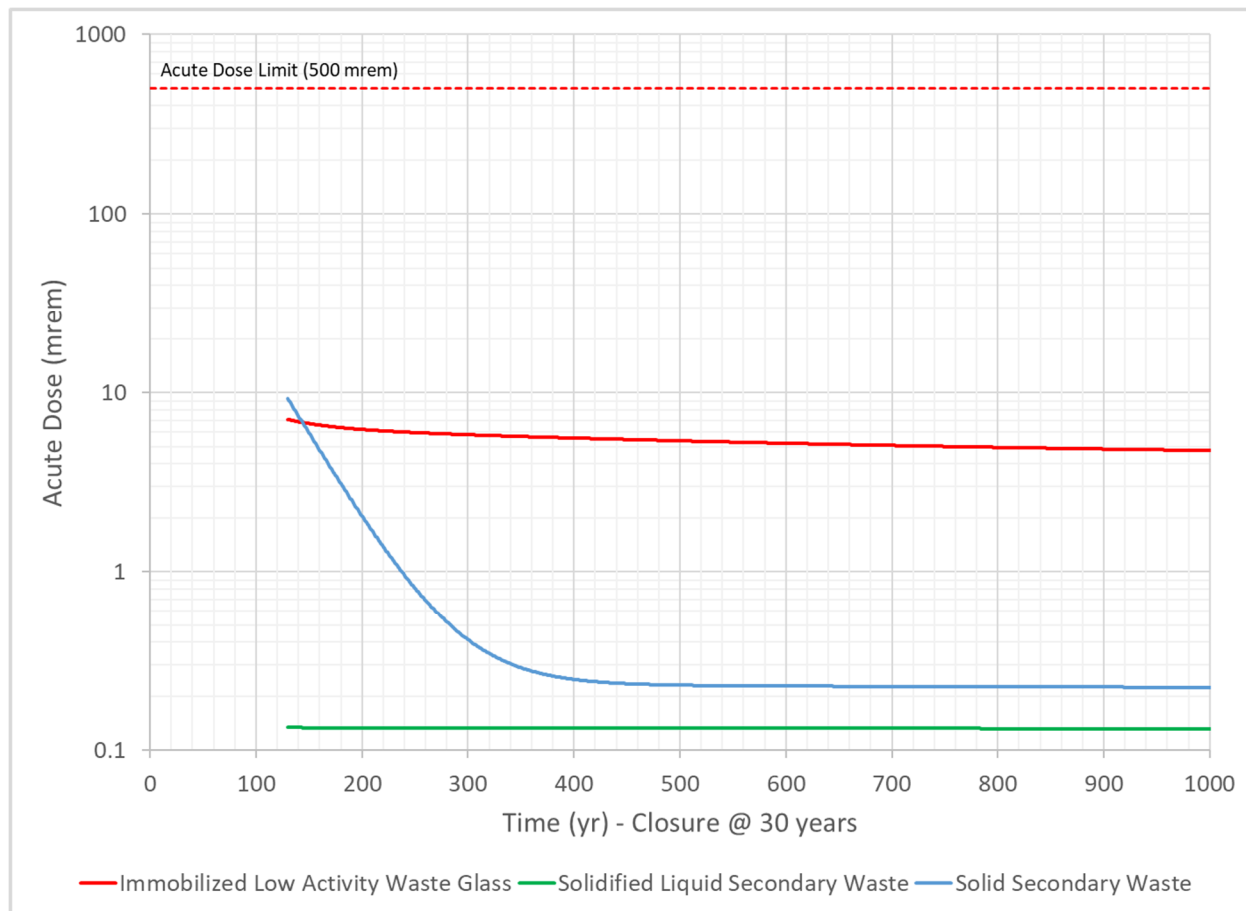

NRC sets forth the following requirements in 10 CFR 61.42, “Protection of individuals from inadvertent intrusion”:

“Design, operation, and closure of the land disposal facility must ensure protection of any individual inadvertently intruding into the disposal site and occupying the site or contacting the waste at any time after active institutional controls over the disposal site are removed.”

As discussed further in Appendix A, DOE’s performance measures for the hypothetical human intruder are more stringent than the dose limit used for NRC’s performance objective at 10 CFR 61.42. Typically, NRC applies a whole-body dose limit of 500 mrem/yr to assess compliance with the requirement at 10 CFR 61.42 (NUREG-1854), whereas DOE imposes a 100 mrem/yr and 500 mrem/yr total effective dose equivalent (excluding radon in air) for chronic and acute inadvertent human intruder exposures, respectively.

The IDF PA shows that there is reasonable expectation that the performance measure related to inadvertent intrusion will be met.

Figure 5-9. Rural Pasture Dose vs. Time After First Receipt at Integrated Disposal Facility.

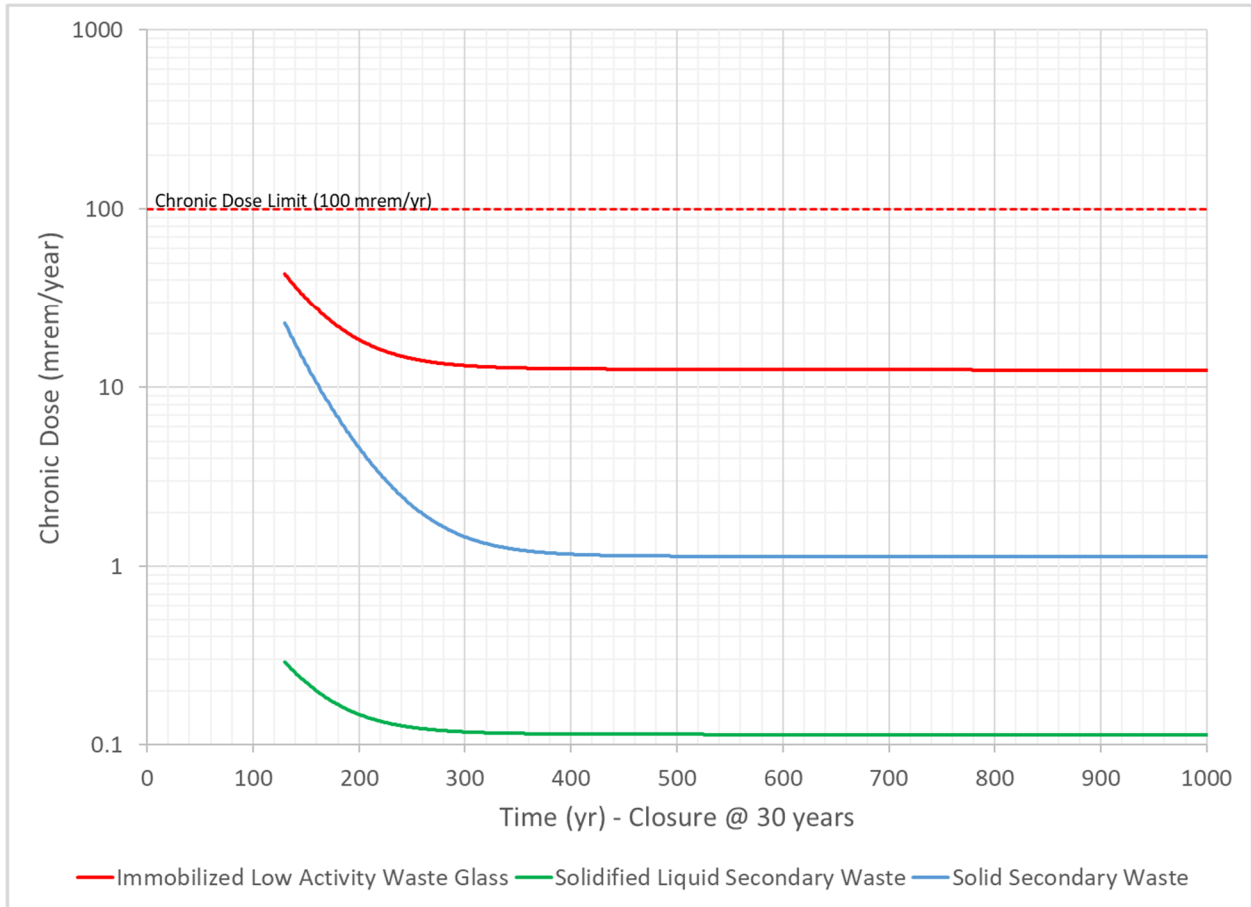

The IDF PA analyses evaluated the most likely scenarios expected to occur in this area:

- A member of the public without knowledge of the disposal site drilling a water well through the waste and through a VLAW container with the drill cuttings being brought to the ground surface, resulting in an acute dose to the driller. The evaluation also considers an intrusion into solidified and encapsulated cementitious wastes with a concentration equal to the bulk average concentration in the cementitious waste forms.

Subsequent to the intrusion, the drill cuttings are dispersed in the area resulting in a continuous dose over the course of one year to the following.

- A rural pasture resident who raises dairy cows in the area contaminated by the drill cuttings. Exposure routes include external exposure, inhalation of soil particulates, incidental soil ingestion, and consumption of milk from cows that graze on contaminated fodder.
- A suburban gardener who lives in the area contaminated by the drill cuttings, grows crops and consumes the produce, and receives direct exposure from the contaminated soil.

- A commercial farm worker who works in the area contaminated by the drill cuttings and receives direct exposure from the contaminated soil.

Of the three chronic exposure scenarios, the rural pasture resident has the greatest potential impact following a hypothetical human intrusion into the waste.

The greatest impact to an inadvertent intruder occurs soon after the exposure is assumed to occur. In the IDF PA analyses, no intruder protection credit is taken for the robustness of the waste containers or waste forms, and the intrusion is assumed to occur after the loss of institutional controls. If the intrusion event were to occur at the end of the shortest institutional control period (ranging from 100 years up to 227 years⁶⁵), simulations reveal that DOE performance measures would not be exceeded.

Table 5-2 shows the results of the inadvertent intruder analyses.

Table 5-2. Integrated Disposal Facility Estimated Peak Dose Following an Inadvertent Intrusion.

| Performance Measure | Limit | Estimated Dose |
|------------------------|-------|----------------|
| Acute Dose (mrem) | 500 | 9.3 |
| Chronic Dose (mrem/yr) | 100 | 43.3 |

From RPP-RPT-59958, *Performance Assessment for the Integrated Disposal Facility, Hanford Site, Washington*, Rev. 1, Table 1-1. Occurs at year 100 after closure (i.e., in 2151).

5.2.5 Protection of Individuals During Operations

The performance objective at 10 CFR 61.43, *Radiation Protection During Operations*, for NRC licensees states the following:

“Operations at the land disposal facility must be conducted in compliance with the standards for radiation protection set out in part 20 of this chapter, except for releases of radioactivity in effluents from the land disposal facility, which shall be governed by §61.41 of this part. Every reasonable effort shall be made to maintain radiation exposures as low as is reasonably achievable.”

The DOE requirements in DOE M 435.1-1, Chapter I.E.(13) for protection of individual during operations read as follows:

“Radioactive waste management facilities, operations, and activities shall meet the requirements of 10 CFR Part 835, *Occupational Radiation Protection*, and DOE [Order] 5400.5 [now DOE O 458.1], *Radiation Protection of the Public and the Environment*.”

⁶⁵ From RPP-CALC-61254, Rev. 3

The DOE's regulatory and contract requirements for DOE facilities and activities ensure compliance with DOE's regulations at 10 CFR Part 835 and relevant DOE Orders that establish dose limits for the public and the workers during operations. In addition, DOE's regulation at 10 CFR 835.101 (c) requires that each radiation protection program include formal plans and measures for applying the ALARA (as low as is reasonably achievable) approach to occupational exposures.

As demonstrated in Appendix A, these DOE requirements are comparable to the NRC requirements at 10 CFR 61.43, "Protection of Individuals During Operations" and the related dose standards at 10 CFR Part 20, "Standards for Protection Against Radiation". The DOE requirements apply to Hanford workers who will be involved with handling and disposal of the VLAW, as well as to the public at the Site.

The cross-referenced "standards for radiation protection" in the NRC regulations at 10 CFR Part 20 that are considered in detail in this Draft WIR Evaluation are the dose limits for the public and the workers during disposal operations set forth in Title 10, CFR, Part 20, Subpart B—Radiation Protection Programs, § 20.1101, Radiation protection programs, item (d); Title 10, CFR, Part 20, Subpart C—Occupational Dose Limits, § 20.1201, Occupational dose limits for adults, items (a)(1)(i), (a)(1)(ii), (a)(2)(i), and (a)(2)(ii); Title 10, CFR, Part 20, Subpart C, § 20.1208, Dose equivalent to an embryo/fetus, item (a); and Title 10, CFR, Part 20, Subpart D—Radiation Dose Limits for Individual Members of the Public, § 20.1301, Dose limits for individual members of the public, items (a)(1), (a)(2), and (b).⁶⁶ This Draft WIR Evaluation also addresses how DOE will maintain doses As Low As Reasonably Achievable (ALARA). Table 5-3 provides a crosswalk between DOE requirements and the relevant standards set forth in 10 CFR Part 20.

⁶⁶ The NRC performance objectives at 10 CFR Part 61, Subpart C apply, by their terms, to NRC licensees. However, neither DOE nor DOE's IDF is or will be licensed by the NRC or an Agreement State, and such licensing and related regulatory authority is not conveyed to NRC or any Agreement State by the Atomic Energy Act of 1954, as amended (42 USC 2011 et seq.), Section 202 of the Energy Reorganization Act of 1974, as amended (42 USC 5842, 42 USC 5801 et seq.), or any other law. It therefore follows that the "standards for radiation protection" in 10 CFR Part 20 (cross-referenced in the performance objective at 10 CFR 61.43), which are relevant in the context of WIR evaluations for non-licensed DOE facilities, are the dose limits for radiation protection of the public and the workers during disposal operations, and not those which address general licensing, administrative, programmatic, or enforcement matters administered by NRC for NRC licensees. Accordingly, this Draft WIR Evaluation addresses in detail the dose limits for the public and workers during disposal operations set forth in 10 CFR Part 20, and like provisions in DOE regulations and Orders. Although 10 CFR 20.1206 (e) contains limits for planned special exposures for adult workers, there will not be any such planned special exposures for closure operations at the IDF. Therefore, this limit is not discussed further in the Draft WIR Evaluation. Likewise, 10 CFR 20.1207 specifies dose limits for minors. However, there will not be minors working at IDF who will receive an occupational dose. Therefore, this limit is not discussed further in this Draft WIR Evaluation.

Table 5-3. Crosswalk Between Applicable 10 CFR Part 20 Standards and U.S. Department of Energy Requirements.

| 10 CFR Part 20 Standard | U.S. Department of Energy Requirement | VLAW WIR Section | Title |
|--------------------------|---------------------------------------|------------------|--|
| 10 CFR 20.1101(d) | DOE O 458.1 | 5.2.6 | Air Emissions Limit for Individual Member of the Public |
| 10 CFR 20.1201(a)(1)(i) | 10 CFR 835.202 (a)(1) | 5.2.7 | Total Effective Dose Equivalent Limit for Adult Workers |
| 10 CFR 20.1201(a)(1)(ii) | 10 CFR 835.202 (a)(2) | 5.2.8 | Any Individual Organ or Tissue Dose Limit for Adult Workers |
| 10 CFR 20.1201(a)(2)(i) | 10 CFR 835.202 (a)(3) | 5.2.9 | Annual Dose Limit to the Lens of the Eye for Adult Workers |
| 10 CFR 20.1201(a)(2)(ii) | 10 CFR 835.202 (a)(4) | 5.2.10 | Annual Dose Limit to the Skin of the Whole Body and to the Skin of the Extremities for Adult Workers |
| 10 CFR 20.1208(a) | 10 CFR 835.206 (a) | 5.2.11 | Dose Equivalent to an Embryo/Fetus |
| 10 CFR 20.1301(a)(1) | DOE O 458.1 | 5.2.12 | Total Effective Dose Equivalent Limit for Individual Members of the Public |
| 10 CFR 20.1301(a)(2) | 10 CFR 835.602 10 CFR 835.603 | 5.2.13 | Dose Limits for Individual Members of the Public in Unrestricted Areas |
| 10 CFR 20.1301(b) | 10 CFR 835.208 | 5.2.14 | Dose Limits for Individual Members of the Public in Controlled Areas |
| 10 CFR 20.1003 | 10 CFR 835.2 | 5.2.15 | As Low As Reasonably Achievable |

Hanford maintains radiation protection programs based on the DOE requirements in 10 CFR Part 835. These programs also comply with various DOE directives and supplemental technical standards. The IDF radiological protection program and ALARA measures that will apply to management of the VLAW are described in CHPRC-00073, *CHPRC Radiological Control Manual*.

The Hanford radiological protection programs include a wide range of controls such as established dose limits, administrative control levels, monitoring of individuals and work areas, control of radiation and contamination areas, use of warning signs and labels, radiation safety training, and formal plans and measures for implementing the ALARA process.

The radiation doses to Hanford workers to be involved in handling of VLAW will be minimized by compliance with the radiological control programs and the associated ALARA process. Compliance with the radiological control program requirements and the ALARA process will provide reasonable expectation that Hanford worker doses will be well below the Site's 500 mrem/yr administrative control level.

Compliance with the DOE radiological control program requirements and the associated ALARA process will also provide reasonable expectation that potential exposures to the public

from disposal of the VLAW are well below DOE limits set forth in 10 CFR Part 835 and DOE O 458.1, and the applicable EPA limit for air emissions.⁶⁷ Among other things, this work will be performed within a radiologically controlled area located within the Site security fences. Past Hanford experience with similar waste management work indicates that potential doses to the public will be very low (DOE/RL-2018-32, *Hanford Annual Site Environmental Report for Calendar Year 2017*).

Consistent with NUREG-1854, the following sections explain that these dose limits correspond to the dose limits in 10 CFR Part 835 and relevant DOE orders that establish DOE regulatory and contractual requirements for DOE facilities and activities. The following sections also show that the IDF operations meet the DOE dose limits and that doses will be maintained ALARA.

5.2.6 Air Emissions Limit for Individual Member of the Public [NRC 10 CFR 20.1101(d); DOE O 458.1, Admin Chg 3]

The NRC regulation at Title 10 CFR Part 20, Subpart B—Radiation Protection Programs, §20.1101, “Radiation protection programs” (10 CFR 20.1101) item (d) provides in relevant part the following:

“[A] constraint on air emissions of radioactive material to the environment, excluding Radon-222 and its daughters, shall be established ... such that the individual member of the public likely to receive the highest dose will not be expected to receive a total effective dose equivalent in excess of 10 mrem (0.1 mSv) per year from these emissions.”

DOE similarly limits effective dose equivalent from air emissions to the public at 10 mrem/yr in DOE O 458.1 to comply with the EPA requirement in 40 CFR Part 61, “National Emission Standards for Hazardous Air Pollutants,” Subpart H—National Emission Standards for Emissions of Radionuclides Other Than Radon From Department of Energy Facilities, §61.92, “Standard” (40 CFR 61.92), which has the same limit. The estimated dose per year from airborne emissions to the maximally exposed individual member of the public located at or beyond the Hanford Site boundary from all operations at the Site ranged from 0.0079 to 0.12 mrem from 2004 through 2013 (PNNL-15222, *Hanford Site Environmental Report for Calendar Year 2004*; PNNL-15892, *Hanford Site Environmental Report for Calendar Year 2005*; PNNL-16623, *Hanford Site Environmental Report for Calendar Year 2006*; PNNL-17603, *Hanford Site Environmental Report for Calendar Year 2007*; PNNL-18427, *Hanford Site Environmental Report for Calendar Year 2008*; PNNL-19455, *Hanford Site Environmental Report for Calendar Year 2009*; PNNL-20548, *Hanford Site Environmental Report for Calendar Year 2010*; DOE/RL-2011-119, *Hanford Site Environmental Report for Calendar Year 2011*; DOE/RL-2013-18, *Hanford Site Environmental Report for Calendar Year 2012*; DOE/RL-2013-47, *Hanford Site Environmental Report for Calendar Year 2013*). These values

⁶⁷ DOE complies with emission standards for hazardous air pollutants promulgated by the EPA in 40 CFR Part 61, “National Emission Standards for Hazardous Air Pollutants,” Subpart H—National Emission Standards for Emissions of Radionuclides Other Than Radon From Department of Energy Facilities.” 40 CFR 61.92, “Standard” imposes an air emission limit of 10 mrem/year to a member of the public.

(0.0079 to 0.12 mrem from 2004 to 2013) are for all Hanford Site operations and are well below the dose limit specified in 10 CFR 20.1101(d) of 10 mrem (0.1 mSv) per year.

5.2.7 Total Effective Dose Equivalent Limit for Adult Workers [NRC 10 CFR 20.1201(a)(1)(i); DOE 10 CFR 835.202(a)(1)]

The NRC regulation at 10 CFR Part 20, Subpart C—Occupational Dose Limits, §20.1201, “Occupational dose limits for adults” (10 CFR 20.1201) item (a) concerning occupational dose limits for adults provides in relevant part the following:

- “(a) ... [C]ontrol the occupational dose to individual adults, except for planned special exposures ... to the following dose limits.
- (1) An annual limit, which is the more limiting of—
 - (i) The total effective dose equivalent being equal to 5 rems (0.05 Sv)[.]”

The DOE regulation in 10 CFR Part 835, Subpart C—Standards for Internal and External Exposure, §835.202, “Occupational dose limits for general employees”, item (a)(1) has the same annual dose limit for the annual occupational dose to general employees. For the occupational dose to adults during IDF operations, the total effective dose (TED) per year will be controlled using the ALARA principles, and will be below 5 rem as described in CHPRC-00073, Table 2-1. Occupational doses to workers have been well below the annual limits specified in 10 CFR 20.1201(a)(1)(i) for all Hanford Site work activities. The TED to workers from IDF operations and closure is expected to remain well below the DOE/NRC limit.

5.2.8 Any Individual Organ or Tissue Dose Limit for Adult Workers [NRC 10 CFR 20.1201(a)(1)(ii); DOE 10 CFR 835.202(a)(2)]

The NRC regulation at 10 CFR 20.1201(a) concerning occupational dose limits for adults provides in relevant part the following:

- “(a) ... [C]ontrol the occupational dose to individual adults, except for planned special exposures ... to the following dose limits.
- (1) An annual limit, which is the more limiting of—
 - ...
 - (ii) The sum of the deep-dose equivalent and the committed dose equivalent to any individual organ or tissue other than the lens of the eye being equal to 50 rems (0.5 Sv).”

The dose limit specified in 10 CFR 20.1201(a)(1)(ii) is similar to the dose limit specified in 10 CFR 835.202(a)(2). For the occupational dose to adults during IDF operations, the sum of the deep-dose equivalent and the committed dose equivalent to any individual organ or tissue other than the lens of the eye will be controlled to ALARA, below the DOE and NRC regulatory limit of 50 rem/yr (CHPRC-00073, Table 2-1).

**5.2.9 Annual Dose Limit to the Lens of the Eye for Adult Workers
[NRC 10 CFR 20.1201(a)(2)(i); DOE 10 CFR 835.202(a)(3)]**

The NRC regulation at 10 CFR 20.1201(a) concerning occupational dose limits for adults provides in relevant part the following:

“(a) ... [C]ontrol the occupational dose to individual adults, except for planned special exposures ... to the following dose limits.

...

(2) The annual limits to the lens of the eye, to the skin of the whole body, and to the skin of the extremities, which are:

(i) A lens dose equivalent of 15 rems (0.15 Sv)[.]”

The dose limit specified in 10 CFR 20.1201(a)(2)(i) is the same as that specified in the DOE regulation at 10 CFR 835.202(a)(3). For the occupational dose to adults during IDF operations, the annual dose limit to the eye lens will be controlled using the ALARA principles, and will be below the DOE and NRC regulatory limit of 15 rem/yr (CHPRC-00073, Table 2-1).

5.2.10 Annual Dose Limit to the Skin of the Whole Body and to the Skin of the Extremities for Adult Workers [NRC 10 CFR 20.1201(a)(2)(ii); DOE 10 CFR 835.202(a)(4)]

The NRC regulation at 10 CFR 20.1201(a) concerning occupational dose limits for adults provides in relevant part the following:

“(a) [C]ontrol the occupational dose to individual adults, except for planned special exposures ... to the following dose limits.

...

(2) The annual limits to the lens of the eye, the skin of the whole body, or to the skin of the extremities, which are:

...

(ii) A shallow-dose equivalent of 50 rem (0.5 Sv) to the skin of the whole body or to the skin of any extremity.”

This NRC dose limit specified in 10 CFR 20.1201(a)(2)(ii) is the same as the DOE dose limit specified at 10 CFR 835.202(a)(4). For the occupational dose to adults during IDF operations that involve limited hands-on activity, the annual dose limit to the skin of the whole body or to the skin of any extremity will be controlled using the ALARA principles and will be below a shallow-dose equivalent of 50 rem/yr (CHPRC-00073, Table 2-1).

5.2.11 Dose Equivalent to an Embryo/Fetus [NRC 10 CFR 20.1208(a); DOE 10 CFR 835.206(a)]

The NRC regulation at 10 CFR Part 20, Subpart C – Occupational Dose Limits, §20.1208, “Dose equivalent to an embryo/fetus” item (a) concerning the dose equivalent to an embryo/fetus provides in relevant part the following:

“(a) ... [E]nsure that the dose equivalent to the embryo/fetus during the entire pregnancy, due to the occupational exposure of a declared pregnant woman, does not exceed 0.5 rem (5 mSv).”

The DOE regulation at 10 CFR 835.206, “Limits for the embryo/fetus”, item (a) has the same dose limit. For the embryo/fetus occupational dose during IDF operations, doses will be controlled so that the dose equivalent to the embryo/fetus during the entire pregnancy for a declared pregnant worker will not exceed 0.5 rem. Furthermore, after pregnancy declaration, DOE provides a mutually agreeable assignment option of work tasks, without loss of pay or promotional opportunity, such that further occupational radiation exposure during the remainder of the gestation period is unlikely. In addition, personnel dosimetry is provided and used to carefully track exposure as controlled by CHPRC-00073, Article 215, Embryo/Fetus Dose Limits.

5.2.12 Total Effective Dose Equivalent Limit for Individual Members of the Public [NRC 10 CFR 20.1301(a)(1); DOE O 458.1, Admin Chg 3]

The NRC regulation at 10 CFR 20.1301, “Dose limits for individual members of the public” item (a) concerning dose limits for individual members of the public provides in relevant part the following:

“(a) ... [C]onduct operations so that—
(1) The total effective dose equivalent to individual members of the public ... does not exceed 0.1 rem (1 mSv) in a year, exclusive of the dose contributions from background radiation, from any medical administration the individual has received, from exposure to individuals administered radioactive material and released ... from voluntary participation in medical research programs, and from the ... disposal of radioactive material into sanitary sewerage[.]”

Provisions in DOE O 458.1 similarly limit public doses to less than 100 mrem/yr. However, the DOE application of the limit is more restrictive, in that it requires DOE to make a reasonable effort to ensure that multiple sources (e.g., DOE sources and NRC regulated sources) do not combine to cause the limit to be exceeded. For individual members of the public during IDF operations, the TED limit to an individual member of the public will be controlled to less than 0.1 rem/yr (CHPRC-00073, Article 214, Member of the Public Dose Limit).

5.2.13 Dose Limits for Individual Members of the Public in Unrestricted Areas [NRC 10 CFR 20.1301(a)(2); DOE 10 CFR 835.602 and 603]

The NRC regulation at 10 CFR 20.1301(a) concerning dose limits for individual members of the public provides in relevant part the following:

“(a) ... [C]onduct operations so that—
...

(2) The dose in any unrestricted area from external sources, exclusive of the dose contributions from patients administered radioactive material and released ... does not exceed 0.002 rem (0.02 millisievert) in any one hour.”

The DOE regulation at 10 CFR 835.602, “Controlled areas” establishes the expectation that TED in controlled areas will be less than 0.1 rem/yr. For individual members of the public during IDF operations, operations will be conducted such that the dose in any unrestricted area from external sources, exclusive of the dose contributions from patients administered radioactive material, will be less than 0.00005 rem/hr above background. CHPRC-00073 Article 214 also restricts the TED in controlled areas to less than 0.1 rem/year. Per 10 CFR 835.603, “Radiological areas and radioactive material areas”, radioactive materials areas have been established for radioactive material accumulation possibly resulting in a radiation dose of greater than or equal to 100 mrem in a year. Therefore, implementation of the provisions at 10 CFR 835.602 and 10 CFR 835.603 provides limits protective of the dose limit specified in 10 CFR 20.1301(a)(2).

5.2.14 Dose Limits for Individual Members of the Public in Controlled Areas [NRC 10 CFR 20.1301(b); DOE 10 CFR 835.208]

The NRC regulation at 10 CFR 20.1301(b) concerning dose limits for individual members of the public provides in relevant part the following:

“(b) If ... members of the public [*are permitted*] to have access to controlled areas, the limits for members of the public continue to apply to those individuals.”

The DOE regulation at 10 CFR 835.208, “Limits for members of the public entering a controlled area” has the same dose limit. The TED limit to an individual member of the public granted access to controlled areas during IDF operations will be controlled to 0.1 rem/yr. Furthermore, training is required for individual members of the public for entry into controlled areas. In addition, to ensure no member of the public exceeds radiation exposure limits, use of dosimetry is required if a member of the public is expected to enter a controlled area and receive a dose that may exceed 0.05 rem/yr (CHPRC-00073, Article 511, Part 1 External Dosimetry Requirements).

5.2.15 As Low As Reasonably Achievable (NRC 10 CFR 20.1003; DOE 10 CFR 835.2)

The NRC regulation at 10 CFR 20.1003, “Definitions” defines ALARA in relevant part as follows:

“*ALARA* ... means making every reasonable effort to maintain exposures to radiation as far below the dose limits ... as is practical consistent with the purpose for which the ... activity is undertaken ...[.]”

The DOE has a similar requirement, and the DOE regulation at 10 CFR 835.2, “Definitions” defines ALARA as “... the approach to radiation protection to manage and control exposures (both individual and collective) to the work force and to the general public to as low as is reasonable...” For radiological work activities during IDF operations, every reasonable effort will be made to maintain exposures to radiation as far below the dose limits as is practical

consistent with the purpose for which the activity is undertaken. Furthermore, the DOE regulation at 10 CFR 835.101, item (c) requires the contents of each radiation protection program to include formal plans and measure for applying the ALARA process to occupational exposure as further discussed in Section 5.2.15.2.

5.2.15.1 Reasonable Expectation

Measures that provide reasonable expectation that IDF operations will comply with the applicable dose limits and with the ALARA provisions include the documented radiation protection program; design, regulatory, and contractual enforcement mechanisms; and access controls, training, and dosimetry. These measures are discussed in the following sections.

5.2.15.2 Integrated Disposal Facility Radiation Protection Program

DOE regulates occupational radiation exposure at its facilities through 10 CFR Part 835, which establishes exposure limits and other requirements to ensure DOE facilities are operated in a manner such that occupational exposure to workers is maintained within acceptable limits and as far below these limits as is reasonably achievable. The requirements in 10 CFR Part 835, if violated, provide a basis for the assessment of civil penalties under Section 234A of the AEA.

Pursuant to 10 CFR Part 835, IDF operations must be conducted in compliance with the documented CH2M HILL Plateau Remediation Company (CHPRC) *Radiological Control Manual* as approved by DOE (CHPRC-00073). The key radiation protection program elements include monitoring of individuals and work areas, access control to areas containing radiation and radioactive materials, use of warning signs and labels, methods to control the spread of radioactive contamination, radiation safety training qualification, objectives for the design of facilities, criteria for radiation and radioactive material workplace levels, and continually updated records to document compliance with the provisions of 10 CFR Part 835. The radiation protection program also includes formal plans and measures for applying the ALARA process.

The 10 CFR Part 835 requirements, as contained in the radiation protection program, are incorporated in the standards/requirement identification document system. The system links the requirements of 10 CFR Part 835 to the company-level and lower-level implementing policies and procedures that control radiological work activities conducted across the Site. These procedures control the planning of radiological work; the use of radiation monitoring devices by employees; the bioassay program; the air monitoring program; the contamination control program; the ALARA program; the training of general employees, radiological workers, radiological control inspectors, and health physics professionals and technicians; and the other aspects of an occupational radiation protection program as required by 10 CFR Part 835.

5.2.15.3 Radiological Design for Protection of Occupational Workers and the Public

The IDF is designed to meet the requirements of 10 CFR Part 835, Subpart K—Design and Control. The CHPRC procedure PRC-PRO-RP-1622 provides the requirements necessary to ensure compliance with 10 CFR Part 835. The procedure refers to 10 CFR Part 835, DOE orders, DOE standards, DOE handbooks, CHPRC manuals, and recognized standards and guides to meet the 10 CFR Part 835-specific requirements and additional requirements to ensure that the design provides for protection of the workers and the environment.

The standard covers the full spectrum of radiological design requirements and not just radiation exposure limits. The following are the specific areas addressed in the procedure: radiation exposure limits, facility and equipment layout, area radiation levels, radiation shielding, internal radiation exposure, radiological monitoring, confinement, and ventilation.

The facility design also incorporates radiation zoning criteria to ensure exposure limits are met by providing adequate radiation shielding. Areas in which non-radiological workers are present are assumed to have continuous occupancy (2,000 hr/yr) and are designed to a dose rate less than 0.05 mrem/hr to ensure the annual dose is less than 100 mrem. Other zoning criteria are established to ensure radiological worker doses are ALARA and less than 1,000 mrem/yr to meet the 10 CFR 835.1002, "Facility design and modifications" design requirements.

The design is also required to provide necessary radiological monitoring or sampling for airborne and surface contamination to ensure that the engineered controls are performing their function and, in the event of a failure or upset condition, workers are warned and exposures avoided.

Radiological protection personnel ensure that applicable requirements of the standard are addressed and presented in design summary documentation. The incorporation of radiological design criteria in the engineering standard ensures that the requirements of 10 CFR Part 835 are met and the design provides for the radiological safety of the workers and environment.

5.2.15.4 Regulatory and Contractual Enforcement

Any violation of the 10 CFR Part 835 requirements is subject to civil penalties pursuant to AEA Section 234A, as implemented by DOE regulations in 10 CFR Part 820, "Procedural Rules for DOE Nuclear Activities". In addition, the requirements in 10 CFR Part 835 and all applicable DOE orders are incorporated into all contracts with DOE contractors. DOE enforces these contractual requirements through contract enforcement measures, including the reduction of contract fees (48 CFR Part 970, "DOE Management and Operating Contracts").

5.2.15.5 Access Controls, Training, Dosimetry and Monitoring

Training or an escort is required for individual members of the public for entry into controlled areas. In addition, use of dosimetry is required if a member of the public is expected to enter a controlled area and exceed 0.05 rem/yr to ensure that no member of the public exceeds radiation exposure limits (CHPRC-00073 Chapters 2 and 5).

In addition, worker radiation exposure monitoring is performed for all workers expected to receive 100 mrem/yr from internal and external sources of radiation to provide assurance that no worker exceeds radiation exposure limits and all radiation dose are maintained as far below the limits as is reasonably achievable (CHPRC-00073 Chapters 2, 5 and 6).

5.2.16 Conclusion for Radiation Protection

Based on the previous discussion, operations at the IDF will be conducted in compliance with the standards for radiation protection set out in 10 CFR Part 20 and 10 CFR Part 835. Every reasonable effort will be made at the IDF to maintain radiation exposures as low as is reasonably achievable.

Measures that provide reasonable expectation that IDF closure will comply with the applicable dose limits and with the ALARA provisions include the documented radiation protection program; design, regulatory, and contractual enforcement mechanisms; and access controls, training, and dosimetry.

5.3 STABILITY OF THE DISPOSAL SITE AFTER CLOSURE

The DOE requirements in DOE M 435.1-1, Chapter IV.Q.(1)(a) and (b) for stability of the disposal site after closure are expressed as follows:

DOE M 435.1-1, Chapter IV.Q.(1)(a) and (b) – “Disposal Facility Closure Plans. A preliminary closure plan shall be developed and submitted to Headquarters for review with the performance assessment and composite analysis. The closure plan shall be updated following issuance of the disposal authorization statement to incorporate conditions specified in the disposal authorization statement. Closure plans shall:

- (a) Be updated as required during the operational life of the facility.
- (b) Include a description of how the disposal facility will be closed to achieve long-term stability and minimize the need for active maintenance following closure and to ensure compliance with the requirements of DOE 5400.5 [now DOE O 458.1], *Radiation Protection of the Public and the Environment.*”

As described in Appendix A, these DOE requirements are comparable to the requirements at 10 CFR 61.44, “Stability of the disposal site after closure.”

The IDF is an expandable, RCRA-compliant landfill with double-lined trenches and a leachate collection system. It is divided lengthwise into two separate disposal cells. One cell is permitted and the other is expected to be permitted by Ecology for disposal of MLLW consistent with the current RCRA permit modification application⁶⁸.

The stability of this facility after closure is enhanced by its location within the 200 East Area in the Central Plateau region near the center of the Hanford reservation, far from Site boundaries, and approximately 650 ft above mean sea level.⁶⁹ At this location, the potential for surface water or groundwater contacting the waste and facilitating contaminant migration is relatively low compared to other locations at Hanford.

For example, the semi-arid Central Plateau region has an average annual rainfall of approximately 6.7 in./yr. Also the IDF site, like the rest of the Central Plateau, would be unaffected by flooding of the Columbia River, which is more than seven miles from the IDF site.

⁶⁸ 20-AMRP-0007, 2019.

⁶⁹ The elevation of the 200 East Area is 653±65 ft above mean sea level (RPP-15833).

The potential for groundwater affecting the buried waste and vice versa is also relatively low. The thickness of the vadose (unsaturated) zone beneath the buried waste is over 200 ft. The IDF was sited at a location so that the emplaced waste is not located within saturated soil, thereby reducing the potential for contaminants in the waste to reach groundwater.

The Central Plateau region is also relatively stable seismically. The largest known earthquake in the Columbia Plateau occurred in 1936 near Milton-Freewater, Oregon, over 70 miles from the IDF and on the far side of the Columbia River with a magnitude of 5.75 on the Richter scale. See Section 2.2.3.6 of this Draft WIR Evaluation for information about other earthquakes and seismic activity.

The above factors help ensure the stability of the IDF after closure. In addition, the design of the VLAW container with the high compressive strength of the vitrified waste form and the minimal allowable void space filled with inert material will minimize the potential for waste subsidence that could impact disposal site stability. Other factors that will promote disposal site stability and minimize the need for active maintenance include compaction of backfill soil and the installation of an engineered barrier over the buried waste. The surface barrier is designed to limit damage caused by wind and water erosion.⁷⁰

The Site has developed a preliminary closure plan for the IDF in accordance with DOE requirements. This plan describes use of a modified RCRA Subtitle C multilayer barrier a minimum of 16.4 ft (5 m) thick above the uppermost level of wastes. The plan was updated in 2019 to align with the IDF PA analyses (CHPRC-03407, *Performance Assessment Closure Plan for the Integrated Disposal Facility*). The plan will be updated as necessary throughout the operational life of the disposal site.

The setting for the IDF and implementation of the preliminary closure plan and its updated versions will ensure that the applicable requirements in DOE M 435.1-1 concerning site stability will be met for the IDF.

An additional DOE M 435.1-1 Chapter IV.Q.(2)(c), requirement is:

DOE M 435.1-1, Chapter IV.Q.(2)(c) – “Disposal Facility Closure. ...
Institutional control measures shall be integrated into land use and stewardship plans and programs, and shall continue until the facility can be released pursuant to DOE O 5400.5 [now DOE O 458.1], *Radiation Protection of the Public and the Environment.*”

DOE anticipates that the Hanford Site will remain in Federal ownership for the foreseeable future (DOE/RL-2001-41). In the event that any of the Hanford Site land areas are transferred to an outside entity, the Institutional Controls that will remain in place on transfer of the land will be conveyed using the appropriate mechanism at the time of the transfer.

⁷⁰ In addition, grouted waste forms for encapsulated HEPA filters and solidified media from carbon bed adsorbers will also have compressive strength requirements (greater than 85 psi) that reduce the potential for subsidence (IDF-00002, *Waste Acceptance Criteria for the Integrated Disposal Facility*).

5.4 INTEGRATED DISPOSAL FACILITY POST-CLOSURE ALARA

The information in this section is summarized from the IDF PA, Section 2.6.5. DOE O 458.1 requires the application of a graded approach to consider optimization of the disposal system to keep doses to members of the public ALARA. DOE O 435.1, *Radioactive Waste Management* does not set forth specific performance objectives for ALARA based on the view that, for disposal, ALARA is a process to reduce potential doses to the public that is not amenable to numerical criteria to limit releases (NCRP Report No. 152, *Performance Assessment of Near-Surface Facilities for Disposal of Low-Level Radioactive Waste*). Since numerical ALARA is not directly applicable to post-closure conditions of a closed disposal facility, the evaluation in the IDF PA instead addresses whether reasonable efforts have been made to ensure that the facility design and operations limit releases of constituents of potential concern (COPCs) so as to be protective of the public. Sensitivity studies addressing the design of the surface cover to limit infiltration into the facility were performed.

For the IDF, the ALARA analysis in the IDF PA focuses on comparing the long-term dose expected to a receptor located 100 m downgradient of the edge of the IDF to the dose from background radiation, along with an evaluation of any potential enhancements in facility performance that could be achieved to further reduce the dose from the IDF. As recommended in DOE-HDBK-1215-2014, *Optimizing Radiation Protection of the Public and the Environment for Use with DOE O 458.1, ALARA Requirements*, the IDF PA contains a qualitative discussion of such considerations.⁷¹

5.5 INTEGRATED DISPOSAL FACILITY PERFORMANCE ASSESSMENT MAINTENANCE

The information in this section is summarized from the IDF PA (RPP-RPT-59958), Section 9.3. The current IDF PA is based on inventory estimates and an assumed allocation of the inventory of constituents of potential concern to specific waste streams and waste forms. The waste form properties are based on assumed formulations that are consistent with current practices for other similar wastes at Hanford.

The IDF PA will be maintained and updated to reflect updated inventory information as the WTP becomes operational, and design and operations decisions are made on the specific VLAW formulations as well as the specific grout formulations that are planned for non-VLAW debris

⁷¹ Engineered barriers to be considered are the double-liner leachate system, waste forms, waste form loading configuration, and the engineered surface cover.

For example, one of the design features that can be used to reduce the potential impact of COPCs released from the IDF is the spatial location of different waste forms. Due to the variability in the waste form and waste stream types, it is expected that different waste forms or waste streams may release risk-significant COPCs at different rates from the source term. The spatial location of the releases may affect the predicted COPC concentrations in the groundwater after the compliance period. IDF PA analyses have been performed to address the potential effects of alternative waste loading scenarios, if it is determined that one of the alternative waste loading scenarios should be used.

and non-VLAW non-debris secondary waste. Additionally, detailed design of the final closure engineered surface cover system is expected to occur.

DOE M 435.1-1 Chg 2 [Chapter IV.P.(4)] includes a requirement for PA maintenance to evaluate the impact of design and operational changes and to incorporate any new information, such as updated information regarding waste forms. In addition to a PA maintenance plan, required documentation in support of the Disposal Authorization Statement for IDF includes a closure plan, monitoring plan, and annual reports documenting any recent changes to the plans for the facility or changes in the understanding of the environmental impacts from the facility.

6.0 THE WASTE DOES NOT EXCEED CLASS C CONCENTRATION LIMITS AND WILL BE MANAGED IN ACCORDANCE WITH U.S. DEPARTMENT OF ENERGY REQUIREMENTS AS LOW-LEVEL WASTE

Section Purpose

The purpose of this section is to demonstrate that the VLAW will be in a solid physical form, will not exceed Class C concentration limits, and will be managed in accordance with DOE requirements as low-level radioactive waste.

Key Points

- The VLAW will be in a solid physical form.
- Calculations show that the VLAW glass will not exceed concentration limits for Class C LLW.

The third and final criterion of DOE M 435.1-1, Chapter II.B.(2)(a) is, in relevant part:

“[The wastes a]re to be managed, pursuant to DOE’s authority under the *Atomic Energy Act of 1954*, as amended, and in accordance with the provisions of Chapter IV of this Manual, provided the waste will be incorporated in a solid physical form at a concentration that does not exceed the applicable concentration limits for Class C low-level waste as set out in 10 CFR 61.55, *Waste Classification*[.]”

Section 6.1 shows that the vitrified LAW will be in a solid physical form and Section 6.2 shows that the radionuclide concentrations will not exceed Class C concentration limits. Section 6.3 explains that the VLAW may be managed as mixed LLW. Section 6.4 concludes that the VLAW will meet the third WIR criterion.

6.1 SOLID PHYSICAL FORMS

The key radionuclides in the LAW stream will be incorporated into a solid physical form of vitrified glass.

6.1.1 Vitrified Glass

The product from the LAW Vitrification Facility will be vitrified borosilicate glass and the resulting immobilized waste will be poured into containers. The borosilicate glass will be highly stable with significant compressive strength and a high degree of chemical durability. Each container is to be at least 90% filled, with inert material (such as glass or sand) being added on top of the glass if necessary to meet this requirement (24590-WTP-PL-RT-03-001).

6.2 RADIONUCLIDE CONCENTRATION LESS THAN CLASS C LIMITS

6.2.1 Class C Limit Requirements

The NRC regulations at 10 CFR 61.55 set forth three classes of LLW—Class A, B, and C—and associated radionuclide concentration limits for each class, for the near-surface disposal of LLW. The waste classification is determined by concentrations of long-lived radionuclides and short-lived radionuclides, set forth in Tables 1 and 2 of 10 CFR 61.55(3), reproduced in Tables 4-1 and 4-2 of this Draft WIR Evaluation. The NRC regulations also provide that for waste containing mixtures of long- and short-lived radionuclides, the total concentration is determined by the sum of the fractions rule as specified in NRC’s regulations at 10 CFR 61.55(a)(7), and the waste classification is determined by 10 CFR 61.55(a)(5).

At the Hanford Site, the VLAW will contain some long-lived radionuclides that are listed on Table 1 of 10 CFR 61.55 (reproduced in Table 4-1 of this Draft WIR Evaluation), and some short-lived radionuclides that are listed on Table 2 of 10 CFR 61.55 (reproduced in Table 4-2 of this Draft WIR Evaluation). Thus, waste classification would be determined as specified in 10 CFR 61.55(a)(5), which states:

“If radioactive waste contains a mixture of radionuclides, some of which are listed in Table 1, and some of which are listed in Table 2, classification shall be determined as follows:

- (i) If the concentration of a nuclide listed in Table 1 does not exceed 0.1 times the value listed in Table 1, the class shall be that determined by the concentration of nuclides listed in Table 2.
- (ii) If the concentration of a nuclide listed in Table 1 exceeds 0.1 times the value listed in Table 1 but does not exceed the value in Table 1, the waste shall be Class C, provided the concentration of nuclides listed in Table 2 does not exceed the value shown in Column 3 of Table 2.”

The concentrations of the various radionuclides in the VLAW glass are determined by dividing the estimated total activity of each radionuclide by the total estimated VLAW glass volume or mass, as applicable.

6.2.1.1 Radiological Characterization of Vitrified Low-Activity Waste Glass

DOE has established maximum radionuclide concentrations for the pretreated feed for the LAW Vitrification Facility that will serve as the basis for conservative glass radionuclide concentration limits and that will ensure that the radionuclide concentrations in the VLAW glass will be less than Class C limits (24590-WTP-ICD-MG-01-030).

Table 6-1 shows estimates for the sum of fractions in the VLAW for each DFLAW campaign decayed to January 1 of the year in which the glass would be made. During DFLAW operation, the tank AP-106 inventory is continuously changing since pretreated feed (with insoluble radionuclides and cesium removed) is periodically batch transferred to the WTP LAW

Vitrification Facility while at the same time TSCR product (fresh pretreated feed) is constantly transferred into tank AP-106. At the WTP LAW Vitrification Facility, LAW feed is combined with WTP EMF evaporator concentrate and glass formers prior to being vitrified in the LAW melters.

**Table 6-1. Summary of Vitrified Low-Activity Waste Glass
Sum of Fractions for each Direct-Feed Low-Activity Waste Campaign.**

| Direct-Feed Low-Activity Waste Campaign | Table 1 Sum of Fractions | Table 2 Sum of Fractions |
|---|--------------------------|--------------------------|
| 1 | 0.0467 | 0.000195 |
| 2 | 0.0816 | 0.000374 |
| 3 | 0.0986 | 0.000417 |
| 4 | 0.0898 | 0.000387 |
| 5 | 0.0931 | 0.000411 |
| 6 | 0.108 | 0.000438 |
| 7 | 0.0873 | 0.000516 |
| 8 | 0.0719 | 0.000529 |
| 9 | 0.0918 | 0.000735 |
| 10 | 0.110 | 0.00146 |
| 11 | 0.172 | 0.00263 |
| 12 | 0.208 | 0.00367 |
| 13 | 0.181 | 0.00295 |
| 14 | 0.154 | 0.00185 |
| 15 | 0.135 | 0.00125 |
| 16 | 0.117 | 0.000942 |
| 17 | 0.105 | 0.000801 |
| 18 | 0.110 | 0.000893 |
| 19 | 0.111 | 0.00113 |
| 20 | 0.119 | 0.00145 |
| 21 | 0.132 | 0.00161 |
| 22 | 0.139 | 0.00146 |
| 23 | 0.133 | 0.00107 |
| 24 | 0.125 | 0.000938 |
| 25 | 0.103 | 0.000846 |
| 26 | 0.0850 | 0.000756 |
| 27 | 0.0793 | 0.000997 |

Note: Sum of Fractions results are shown in three significant figures.

RPP-CALC-63643, *Sum of Fractions Calculations for DFLAW Immobilized LAW Glass.*

6.2.1.2 Immobilized Low-Activity Waste Sum of Fractions Calculation Results

Table 6-2 shows that the radionuclides in the DFLAW VLAW glass with maximum sum of fractions will be well below Class C limits.

Table 6-2. Direct-Feed Low-Activity Waste Vitrified Low-Activity Waste Glass Maximum Sum of Fractions for 10 CFR 61.55 Table 1 Radionuclides.

| Radionuclide | Class C Limit ^a (Ci/m ³) | Class C Limit ^a (nCi/g) | VLAW Glass Concentration ^b (Ci/m ³) | VLAW Glass Concentration (nCi/g) ^b | Table 1 Fraction |
|-------------------------|---|------------------------------------|--|---|------------------|
| ¹⁴ C | 8.00E+00 | N/A | 0.00E+00 | N/A | 0.00E+00 |
| ⁹⁹ Tc | 3.0E+00 | N/A | 2.62E-01 | N/A | 8.72E-02 |
| ¹²⁹ I | 8.00E-02 | N/A | 3.59E-04 | N/A | 4.49E-03 |
| ²³⁷ Np | N/A | 1.00E+02 | N/A | 2.65E-02 | 2.65E-04 |
| ²³⁸ Pu | N/A | 1.00E+02 | N/A | 2.19E-01 | 2.19E-03 |
| ²³⁹ Pu | N/A | 1.00E+02 | N/A | 4.52E+00 | 4.52E-02 |
| ²⁴⁰ Pu | N/A | 1.00E+02 | N/A | 1.04E+00 | 1.04E-02 |
| ²⁴¹ Pu | N/A | 3.50E+03 | N/A | 3.75E+00 | 1.07E-03 |
| ²⁴² Pu | N/A | 1.00E+02 | N/A | 4.75E-04 | 4.75E-06 |
| ²⁴¹ Am | N/A | 1.00E+02 | N/A | 5.61E+00 | 5.61E-02 |
| ²⁴³ Am | N/A | 1.00E+02 | N/A | 3.30E-03 | 3.30E-05 |
| ²⁴² Cm | N/A | 2.00E+04 | N/A | 6.66E-02 | 3.33E-06 |
| ²⁴³ Cm | N/A | 1.00E+02 | N/A | 3.14E-03 | 3.14E-05 |
| ²⁴⁴ Cm | N/A | 1.00E+02 | N/A | 5.61E-02 | 5.61E-04 |
| Sum of Fractions | | | | | 0.208 |

^a 10 CFR 61, "Licensing Requirements for Land Disposal of Radioactive Waste," Subpart D—Technical Requirements for Land Disposal Facilities, §61.55, "Waste classification," Table 1.

^b RPP-CALC-63643, *Sum of Fractions Calculations for DFLAW Immobilized LAW Glass*.

VLAW = vitrified low-activity waste

N/A = not applicable

The 10 CFR 61.55 Table 1 sum of fractions maximum in DFLAW ILAW glass is 0.208 and the 10 CFR 61.55 Table 2 sum of fractions maximum in DFLAW ILAW glass as shown in Table 6-3 is 0.00367. Accordingly, the DFLAW ILAW glass will not exceed the Class C concentration limits for disposal as LLW.

**Table 6-3. Direct-Feed Low-Activity Waste Vitrified Low-Activity Waste Glass
Maximum Sum of Fractions for 10 CFR 61.55 Table 2 Radionuclides.**

| Radionuclide | Class C Limit ^a (Ci/m³) | VLAW Glass Concentration ^b (Ci/m³) | Table 2 Fraction ^b |
|-------------------------|--|---|--------------------------------------|
| ³ H | c | 0.00E+00 | No limits |
| ⁶⁰ Co | c | 8.03E-04 | No limits |
| ⁵⁹ Ni | 7.00E+02 | 6.61E-02 | 1.30E-04 |
| ⁹⁰ Sr | 7.00E+03 | 6.96E+00 | 3.52E-03 |
| ¹³⁷ Cs | 4.60E+03 | 4.79E-02 | 1.11E-05 |
| Sum of Fractions | | | 0.00367 |

^a 10 CFR 61, "Licensing Requirements for Land Disposal of Radioactive Waste," Subpart D—Technical Requirements for Land Disposal Facilities, §61.55, "Waste classification," Table 1.

^b RPP-CALC-63643, *Sum of Fractions Calculations for DFLAW Immobilized LAW Glass*.

^c No established limits for these radionuclides in Class B or C wastes per 10 CFR 61.55 Table 2.

ILAW = immobilized low-activity waste

6.3 CONCLUSIONS ON SOLID PHYSICAL FORM AND CLASS C

The DFLAW approach VLAW will be in a solid physical form, and with the maximum sum of fractions for both long- and short-lived radioisotopes below 1, will not exceed concentration limits for Class C LLW. The VLAW will therefore meet the third WIR criterion in DOE M 435.1-1, Chapter II.B.2(a).

This page is intentionally left blank.

7.0 CONCLUSION

Based on the information and analysis provided in the preceding sections of this Draft WIR Evaluation and its references, this Draft WIR Evaluation demonstrates that the VLAW will meet the criteria in Chapter II.B.(2)(a) of DOE M 435.1-1.

With respect to the first criterion in DOE M 435.1-1, this Draft WIR Evaluation shows that key radionuclides will be removed to the maximum extent that is technically and economically practical using the DFLAW approach. As discussed in this Draft WIR Evaluation, the DFLAW approach is expected to remove more than 99% of the cesium and also remove other key radionuclides.

Regarding the second criterion in DOE M 435.1-1, this Draft WIR Evaluation demonstrates that disposal of the VLAW in the IDF will meet the DOE safety requirements for LLW disposal and the comparable NRC performance objectives at 10 CFR Part 61, Subpart C. For example, the performance assessment base case (which also includes other wastes) within 1,000 years post-closure shows an all-pathways, annual dose to a member of the public of approximately 0.19 millirem, which is well below the 25 millirem performance objective.

Consistent with the third criterion in DOE M 435.1-1, the vitrified LAW will be in a solid physical form. As discussed in this Draft WIR Evaluation, the maximum radionuclide concentrations in the VLAW glass will be well below the concentration limits for Class C LLW.

DOE is consulting with the NRC concerning this Draft WIR Evaluation, and is issuing this Draft WIR Evaluation for comments by States, Tribal Nations, stakeholders and the public. Following consultation with the NRC and consideration of comments from States, Tribal Nations, stakeholders and the public, DOE plans to issue a final WIR Evaluation. Based on the final WIR Evaluation, DOE may determine (in a future WIR Determination) whether the VLAW generated by the DFLAW approach meets the criteria in Chapter II.B.(2)(a) of DOE M 435.1-1, is not HLW, and may be managed (disposed of) as LLW.

This page is intentionally left blank.

8.0 REFERENCES

- 0078886, 2008, “Re: Draft Waste Treatment and Immobilization Plant (WTP) Dangerous Waste Permit” (letter from J. A. Hedges to S. J. Olinger [U.S. Department of Energy, Office of River Protection], D. A. Brockman [U.S. Department of Energy, Richland Operations Office], and W. S. Elkins [Bechtel National, Inc.], October 15), State of Washington Department of Ecology, Richland, Washington.
- 10 CFR Part 20, “Standards for Protection Against Radiation,” *Code of Federal Regulations*, as amended.
- 10 CFR Part 20, “Standards for Protection Against Radiation,” Subpart B—Radiation Protection Programs, §20.1101, “Radiation protection programs,” *Code of Federal Regulations*, as amended.
- 10 CFR Part 20, “Standards for Protection Against Radiation,” Subpart C—Occupational Dose Limits, §20.1201, “Occupational dose limits for adults,” *Code of Federal Regulations*, as amended.
- 10 CFR Part 20, “Standards for Protection Against Radiation,” Subpart C—Occupational Dose Limits, §20.1208, “Dose equivalent to an embryo/fetus,” *Code of Federal Regulations*, as amended.
- 10 CFR Part 20, “Standards for Protection Against Radiation,” Subpart D—Radiation Dose Limits for Individual Members of the Public, §20.1301, “Dose limits for individual members of the public,” *Code of Federal Regulations*, as amended.
- 10 CFR Part 20, “Standards for Protection Against Radiation,” Subpart E—Radiological Criteria for License Termination, *Code of Federal Regulations*, as amended.
- 10 CFR Part 61, “Licensing Requirements for Land Disposal of Radioactive Waste,” *Code of Federal Regulations*, as amended.
- 10 CFR Part 61, “Licensing Requirements for Land Disposal of Radioactive Waste,” Subpart C—Performance Objectives, *Code of Federal Regulations*, as amended.
- 10 CFR Part 61, “Licensing Requirements for Land Disposal of Radioactive Waste,” Subpart C—Performance Objectives, §61.40, “General requirement,” *Code of Federal Regulations*, as amended.
- 10 CFR Part 61, “Licensing Requirements for Land Disposal of Radioactive Waste,” Subpart C—Performance Objectives, §61.41, “Protection of the general population from releases of radioactivity,” *Code of Federal Regulations*, as amended.
- 10 CFR Part 61, “Licensing Requirements for Land Disposal of Radioactive Waste,” Subpart C—Performance Objectives, §61.42, “Protection of individuals from inadvertent intrusion,” *Code of Federal Regulations*, as amended.

- 10 CFR Part 61, “Licensing Requirements for Land Disposal of Radioactive Waste,” Subpart C—Performance Objectives, §61.43, “Protection of individuals during operations,” *Code of Federal Regulations*, as amended.
- 10 CFR Part 61, “Licensing Requirements for Land Disposal of Radioactive Waste,” Subpart C—Performance Objectives, §61.44, “Stability of the disposal site after closure,” *Code of Federal Regulations*, as amended.
- 10 CFR Part 61, “Licensing Requirements for Land Disposal of Radioactive Waste,” Subpart D—Technical Requirements for Land Disposal Facilities, §61.55, “Waste classification,” *Code of Federal Regulations*, as amended.
- 10 CFR Part 820, “Procedural Rules for DOE Nuclear Activities,” *Code of Federal Regulations*, as amended.
- 10 CFR Part 835, “Occupational Radiation Protection,” *Code of Federal Regulations*, as amended.
- 10 CFR Part 835, “Occupational Radiation Protection,” Subpart A—General Provisions, §835.2, “Definitions,” *Code of Federal Regulations*, as amended.
- 10 CFR Part 835, “Occupational Radiation Protection,” Subpart B—Management and Administrative Requirements, §835.101, “Radiation protection programs,” *Code of Federal Regulations*, as amended.
- 10 CFR Part 835, “Occupational Radiation Protection,” Subpart C—Standards for Internal and External Exposure, §835.202, “Occupational dose limits for general employees,” *Code of Federal Regulations*, as amended.
- 10 CFR Part 835, “Occupational Radiation Protection,” Subpart C—Standards for Internal and External Exposure, §835.206, “Limits for the embryo/fetus,” *Code of Federal Regulations*, as amended.
- 10 CFR Part 835, “Occupational Radiation Protection,” Subpart C—Standards for Internal and External Exposure, §835.208, “Limits for members of the public entering a controlled area,” *Code of Federal Regulations*, as amended.
- 10 CFR Part 835, “Occupational Radiation Protection,” Subpart G—Posting and Labeling, §835.602, “Controlled areas,” *Code of Federal Regulations*, as amended.
- 10 CFR Part 835, “Occupational Radiation Protection,” Subpart G—Posting and Labeling, §835.603, “Radiological areas and radioactive material areas,” *Code of Federal Regulations*, as amended.
- 10 CFR Part 835, “Occupational Radiation Protection,” Subpart K—Design and Control, §835.1002, “Facility design and modifications,” *Code of Federal Regulations*, as amended.

- 20-AMRP-0007, 2019, *Submittal of Hanford Facility Dangerous Waste Class 3 Permit Modification Request to Update the Operating Permit for the Integrated Disposal Facility (IDF) Operating Unit Group (OUG) 11*, Brian T. Vance to Ms. Alexandra K. Smith.
- 35 FR 17530, 1970, “Licensing of Production and Utilization Facilities,” *Federal Register*, Vol. 35, pp. 17530–17533 (November 14).
- 40 CFR Part 61, “National Emission Standards for Hazardous Air Pollutants,” Subpart H—National Emission Standards for Emissions of Radionuclides Other Than Radon From Department of Energy Facilities, §61.92, “Standard,” *Code of Federal Regulations*, as amended.
- 40 CFR Part 141, “National Primary Drinking Water Regulations,” Subpart C—Monitoring and Analytical Requirements, §141.23, “Inorganic chemical sampling and analytical requirements,” *Code of Federal Regulations*, as amended.
- 40 CFR Part 141, “National Primary Drinking Water Regulations,” Subpart G—National Primary Drinking Water Regulations: Maximum Contaminant Levels and Maximum Residual Disinfectant Levels, §141.66, “Maximum contaminant levels for radionuclides,” *Code of Federal Regulations*, as amended.
- 48 CFR Part 970, “DOE Management and Operating Contracts,” *Code of Federal Regulations*, as amended.
- 78 FR 75913, 2013, “Record of Decision: Final Tank Closure and Waste Management Environmental Impact Statement for the Hanford Site, Richland, Washington,” *Federal Register*, Vol. 78, pp. 75913–75919 (December 13).
- 83 FR 23270, 2018, “Amended Record of Decision for the Management of Cesium and Strontium Capsules at the Hanford Site, Richland, Washington,” *Federal Register*, Vol. 83, pp. 23270–23271 (May 18).
- 84 FR 424, 2019, “Amended Record of Decision for the Direct-Feed Low-Activity Waste Approach at the Hanford Site, Washington,” *Federal Register*, Vol. 84, pp. 424–425, (January 28).
- 24590-WTP-ICD-MG-01-030, 2015, *ICD-30 – Interface Control Document for Direct LAW Feed*, Rev. 0, Bechtel National, Inc., Richland, Washington.
- 24590-WTP-ICF-MGT-17-0002, 2017, *Increase Nominal Particle Diameter for Filtration*, Bechtel National, Inc., Richland, Washington.
- 24590-WTP-PL-PENG-14-0006, 2018, *Secondary Wastes Compliance Plan*, Rev. 2, Bechtel National, Inc., Richland, Washington.

24590-WTP-PL-RT-03-001, 2011, *ILAW Product Compliance Plan*, Rev. 5, Bechtel National, Inc., River Protection Project, Waste Treatment Plant, Richland, Washington.

Atomic Energy Act of 1954, 42 USC 2901 et seq., as amended.

Bernero, R. M., 1993, letter from providing States of Washington and Oregon: Denial of Petition for Rulemaking to J. Lytle, Deputy Assistant Secretary for Waste Operations, Office of Environmental Restoration and Waste Management, U.S. Department of Energy, Washington, D.C., March 2, Office of Nuclear Materials Safety and Safeguards, U.S. Nuclear Regulatory Commission, Washington, D.C.

Cambridge, 2014, *Cambridge Dictionaries Online*, Queried 06/16/2014, [“practical”], <http://dictionary.cambridge.org>.

CHPRC-00073, 2017, *CHPRC Radiological Control Manual*, Rev. 12, CH2M HILL Plateau Remediation Company, Richland, Washington.

CHPRC-03407, 2019, *Performance Assessment Closure Plan for the Integrated Disposal Facility*, Rev. 1, CH2M HILL Plateau Remediation Company/INTERA, Inc., Richland, Washington.

CNWRA, 1997, *Report on DOE Hanford Tank Waste Classification*, Center for Nuclear Waste Regulatory Analyses, San Antonio, Texas.

Comprehensive Environmental Response, Compensation, and Liability Act of 1980, 42 USC 9622, et seq.

Consent Decree, *State of Washington v. Department of Energy*, Case No. 2:08-CV-5085-FVS, United States District Court, Eastern District of Washington (October 25, 2010).

Amended Consent Decree, *State of Washington v. Department of Energy*, Case No. 2:08-CV-5085-RMP, United States District Court, Eastern District of Washington (March 11, 2016).

DOE 2019, *Design and Construction of the Hanford Tank Waste Treatment and Immobilization Plant*, Contract No. DE-AC27-01RV14136, U.S. Department of Energy Office of River Protection, August 31, 2000 (Section C Statement of Work confirmed through Modification No. 463, August 13, 2019).

DOE/EIS-0222-F, 1999, *Final Hanford Comprehensive Land-Use Plan Environmental Impact Statement*, U.S. Department of Energy, Richland Operations Office, Richland, Washington.

DOE/EIS-0310, 2000, *Final Programmatic Environmental Impact Statement for Accomplishing Expanded Civilian Nuclear Energy Research and Development and Isotope Production Missions in the United States, Including the Role of the Fast Flux Test Facility*,

- U.S. Department of Energy, Office of Nuclear Energy, Science and Technology,
Washington, D.C.
- DOE/EIS-0391, 2012, *Final Tank Closure and Waste Management Environmental Impact Statement for the Hanford Site, Richland, Washington*, U.S. Department of Energy, Washington, D.C.
- DOE/EIS-0391-SA-02, 2019, *Supplement Analysis of the Final Tank Closure and Waste Management Environmental Impact Statement for the Hanford Site, Richland, Washington*, U.S. Department of Energy, Office of River Protection, Richland, Washington.
- DOE G 435.1-1, 1999, *Implementation Guide for use with DOE M 435.1-1*, U.S. Department of Energy, Washington, D.C.
- DOE-HDBK-1215-2014, 2014, *Optimizing Radiation Protection of the Public and the Environment for Use with DOE O 458.1, ALARA Requirements*, U.S. Department of Energy, Washington, D.C.
- DOE M 435.1-1, 2011, *Radioactive Waste Management Manual, Change 2*, U.S. Department of Energy, Washington, D.C.
- DOE O 413.3B, 2018, *Program and Project Management for the Acquisition of Capital Assets*, U.S. Department of Energy, Washington, D.C.
- DOE O 435.1, 2007, *Radioactive Waste Management, Change 1*, U.S. Department of Energy, Washington, D.C.
- DOE O 458.1, 2013, *Radiation Protection of the Public and the Environment, Admin Chg 3*, U.S. Department of Energy, Washington, D.C.
- DOE/RL-2001-41, 2019, *Sitewide Institutional Controls Plan for Hanford CERCLA Response Actions and RCRA Corrective Actions*, Rev. 9, U.S. Department of Energy, Richland Operations Office, Richland, Washington.
- DOE/RL-2002-39, 2002, *Standardized Stratigraphic Nomenclature for Post-Ringold-Formation Sediments Within the Central Pasco Basin*, Rev. 0, U.S. Department of Energy, Richland Operations Office, Richland, Washington.
- DOE/RL-2011-119, 2012, *Hanford Site Environmental Report for Calendar Year 2011*, Rev. 0, U.S. Department of Energy, Richland Operations Office, Richland, Washington.
- DOE/RL-2013-18, 2013, *Hanford Site Environmental Report for Calendar Year 2012*, Rev. 0, U.S. Department of Energy, Richland Operations Office, Richland, Washington.
- DOE/RL-2013-47, 2014, *Hanford Site Environmental Report for Calendar Year 2013*, Rev. 0, U.S. Department of Energy, Richland Operations Office, Richland, Washington.

DOE/RL-2016-62, 2017, *Annual Status Report (FY 2016): Composite Analysis for Low Level Waste Disposal in the Central Plateau of the Hanford Site*, Rev. 0, U.S. Department of Energy, Richland Operations Office, Richland, Washington.

DOE/RL-2018-32, 2018, *Hanford Annual Site Environmental Report for Calendar Year 2017*, Rev. 0, U.S. Department of Energy, Richland Operations Office, Richland, Washington.

DOE-STD-1196-2011, 2011, *DOE Standard, Derived Concentration Technical Standard*, U.S. Department of Energy, Washington, D.C.

DOE-STD-5002-2017, 2017, *DOE Standard Disposal Authorization Statement and Tank Closure Documentation*, U.S. Department of Energy, Washington, D.C.

ECF-HANFORD-13-0029, 2017, *Development of the Hanford South Geologic Framework Model, Hanford Site, Washington Fiscal Year 2016 Update*, Rev. 4, ch2m, Richland, Washington.

Ecology et al, 1989, *Hanford Federal Facility Agreement and Consent Order – Tri-Party Agreement*, 2 vols., as amended, State of Washington Department of Ecology, U.S. Environmental Protection Agency, and U.S. Department of Energy, Olympia, Washington.

EPA 815-R-02-001, 2002, *Radionuclides in Drinking Water: A Small Entity Compliance Guide*, Office of Ground Water and Drinking Water, U.S. Environmental Protection Agency, Washington, D.C.

Fowler, H. W., 1930, *A Dictionary of Modern English Usage*, Oxford University Press, University of Oxford, United Kingdom.

HNF-EP-0182, 2019, *Waste Tank Summary Report for Month Ending June 30, 2019*, Rev. 378, Washington River Protection Solutions, LLC, Richland, Washington.

HNF-EP-0182, 2019, *Waste Tank Summary Report for Month Ending July 31, 2019*, Rev. 379, Washington River Protection Solutions, LLC, Richland, Washington.

Honeywell UOP, Queried 09/20/2018, [*Adsorbents for Nuclear Waste Remediation*], <https://www.uop.com/products/adsorbents/nuclear-waste-remediation/>.

IDF-00002, 2019, *Waste Acceptance Criteria for the Integrated Disposal Facility*, Rev. 0, CH2M HILL Plateau Remediation Company, Richland, Washington.

LA-UR-96-3860, 1997, *Hanford Tank Chemical and Radionuclide Inventories: HDW Model Rev. 4*, Los Alamos National Laboratory, Los Alamos, New Mexico.

Low-Level Radioactive Waste Policy Amendments Act of 1985, 42 USC 2021b, et seq.

National Academy of Sciences, 2006, Tank Waste Retrieval, Processing, and On-site Disposal at Three Department of Energy Sites: Final Report, The National Academies Press, Washington, D.C.

NCRP Report No. 152, 2005, *Performance Assessment of Near-Surface Facilities for Disposal of Low-Level Radioactive Waste*, National Council on Radiation Protection and Measurements, Bethesda, Maryland.

NRC, 1997, “Classification of Hanford Low-Activity Waste Fraction” (letter from C. J. Paperiello, Office of Nuclear Material Safety and Safeguards to J. Kinzer, U.S. Department of Energy, Richland Operations Office, June 9), U.S. Nuclear Regulatory Commission, Washington, D.C.

Nuclear Waste Policy Act of 1982, 42 USC 10101, et seq.

NUREG-0945, 1982, *Final Environmental Impact Statement on 10 CFR 61 “Licensing Requirements for Land Disposal of Radioactive Waste”*: Summary and Main Report, Volume 1, U.S. Nuclear Regulatory Commission, Washington, D.C.

NUREG-1757, 2006, *Consolidated Decommissioning Guidance: Characterization, Survey, and Determination of Radiological Criteria, Final Report*, Vol. 2, Rev. 1, Office of Nuclear Material Safety and Safeguards, U.S. Nuclear Regulatory Commission, Washington, D.C.

NUREG-1854, 2007, *NRC Staff Guidance for Activities Related to U.S. Department of Energy Waste Determinations – Draft Final Report for Interim Use*, U.S. Nuclear Regulatory Commission, Office of Federal and State Materials and Environmental Management Programs, Washington, D.C.

ORNL/TM-2001/129, 2001, *Wastewater Triad Project: Final Summary Report*, Oak Ridge National Laboratory, Oak Ridge, Tennessee.

ORP-11242, 2017, *River Protection Project System Plan*, Rev. 8, U.S. Department of Energy, Office of River Protection, Richland, Washington.

PNNL-13605, 2003, *A Short History of Hanford Waste Generation, Storage, and Release*, Rev. 4, Pacific Northwest National Laboratory, Richland, Washington.

PNNL-14586, 2005, *Geologic Data Package for 2005 Integrated Disposal Facility Performance Assessment*, Rev. 1, Pacific Northwest National Laboratory, Richland, Washington.

PNNL-15222, 2005, *Hanford Site Environmental Report for Calendar Year 2004*, Pacific Northwest National Laboratory, Richland, Washington.

PNNL-15237, 2005, *Geology of the Integrated Disposal Facility Trench*, Pacific Northwest National Laboratory, Richland, Washington.

PNNL-15892, 2006, *Hanford Site Environmental Report for Calendar Year 2005*, Pacific Northwest National Laboratory, Richland, Washington.

PNNL-16623, 2007, *Hanford Site Environmental Report for Calendar Year 2006*, Pacific Northwest National Laboratory, Richland, Washington.

PNNL-17603, 2008, *Hanford Site Environmental Report for Calendar Year 2007*, Pacific Northwest National Laboratory, Richland, Washington.

PNNL-17913, 2009, *Hydrogeology of the Hanford Site Central Plateau – A Status Report for the 200 West Area*, Rev. 1. Pacific Northwest National Laboratory, Richland, Washington.

PNNL-18427, 2009, *Hanford Site Environmental Report for Calendar Year 2008*, Pacific Northwest National Laboratory, Richland, Washington.

PNNL-19455, 2010, *Hanford Site Environmental Report for Calendar Year 2009*, Pacific Northwest National Laboratory, Richland, Washington.

PNNL-20548, 2011, *Hanford Site Environmental Report for Calendar Year 2010*, Pacific Northwest National Laboratory, Richland, Washington.

PNNL-28780, 2019, *Fiscal Year 2019 Filtration of Hanford Tank AP-107 Supernatant*, RPT-DFTP-015, Rev. 0, Pacific Northwest National Laboratory, Richland, Washington.

PNNL-28783, 2019, *Dead-End Filtration and Crystalline Silicotitanate Cesium Ion Exchange with Hanford Tank Waste AW-102*, RPT-TCT-003, Rev. 0, Pacific Northwest National Laboratory, Richland, Washington.

PRC-PRO-RP-1622, *Radiological Design Review Process*, Rev. 2 Chg. 1, CH2M HILL Plateau Remediation Company, Richland, Washington.

Random House, 1997, Random House Unabridged Dictionary, Random House, Inc., <http://www.infoplease.com/dictionary.html>, web page visited September 20, 2018.

RCW 70.105, “Hazardous Waste Management,” *Revised Code of Washington*, as amended.

Resource Conservation and Recovery Act of 1976, 42 USC 6901, et seq.

Ronald W. Reagan National Defense Authorization Act for Fiscal Year 2005, Section 3116, H.R. 4200 (Pub. L. 108-375), Section 3116.

RPP-7625, 2019, *Guidelines for Updating Best-Basis Inventory*, Rev. 14, Washington River Protection Solutions, LLC, Richland, Washington.

RPP-10006, 2019, *Methodology and Calculations for the Assignment of Waste Groups for the Large Underground Waste Storage Tanks at the Hanford Site*, Rev. 17, Washington River Protection Solutions, LLC, Richland, Washington.

RPP-13489, 2002, *Activity of Fuel Batches Processed Through Hanford Separations Plants, 1944 Through 1989*, Rev. 0, Fluor Hanford, Inc., Richland, Washington.

RPP-15833, 2003, *System Specification for the Integrated Disposal Facility*, Rev. 0, Wastren, Inc./CH2M HILL Hanford Group, Inc., Richland, Washington.

RPP-40149-VOL2, 2019, *Integrated Waste Feed Delivery Plan: Volume 2 – Campaign Plan*, Rev. 05A, Washington River Protection Solutions, LLC, Richland, Washington.

RPP-CALC-61254, 2019, *Inadvertent Intruder Dose Calculation Update for the Integrated Disposal Facility Performance Assessment*, Rev. 3, Washington River Protection Solutions, LLC/Orano Federal Services LLC, Richland, Washington.

RPP-CALC-62497, *Tank Side Cesium Removal (TSCR) IXC-150 Sizing*, Rev. 2, AVANTech Incorporated, Richland, Washington.

RPP-CALC-63643, 2019, *Sum of Fractions Calculations for DFLAW Immobilized LAW Glass*, Rev. 3, Washington River Protection Solutions, LLC, Richland, Washington.

RPP-PLAN-54676, 2013, *Technetium Removal Technology Development Plan for Elutable Ion Exchange*, Rev. 0, Washington River Protection Solutions, LLC, Richland, Washington.

RPP-PLAN-62353, 2019, *Tank 241-AP-106 Cs-137 Removal for Repurposing Process Control Plan*, Rev. 3, Washington River Protection Solutions, LLC, Richland, Washington.

RPP-RPT-57991, 2019, *River Protection Project Integrated Flowsheet*, 24590-WTP-RPT-MGT-14-023, Rev. 3, Washington River Protection Solutions, LLC, Richland, Washington.

RPP-RPT-58971, 2020, *Effluent Management Facility Evaporator Concentrate – Purge Alternatives Evaluation*, Rev. 1, Washington River Protection Solutions, LLC, Richland, Washington.

RPP-RPT-59958, 2018, *Performance Assessment for the Integrated Disposal Facility, Hanford Site, Washington*, Rev. 1, Washington River Protection Solutions, LLC, Richland, Washington.

RPP-RPT-60405, 2017, *External Expert Review of the Low-Activity Waste Pretreatment System (LAWPS) Project*, Rev. 0, Washington River Protection Solutions, LLC, Richland, Washington.

RPP-RPT-61188, 2019, *Tank Side Cesium Removal (TSCR) and Spent Ion-Exchange Column Storage Pad Preliminary Documented Safety Analysis*, Rev. 0, Washington River Protection Solutions, LLC, Richland, Washington.

Safe Drinking Water Act of 1974, 42 USC 300, et seq.

SESC-EN-RPT-005, 1997, *Hanford Complexant Concentrate Cesium Removal Using Crystalline Silicotitanate*, Rev. 0, SGN Eurisys Services Corporation, Richland, Washington.

SESC-EN-RPT-006, 1997, *Hanford Saltcake Cesium Removal Using Crystalline Silicotitanate*, SGN Eurisys Services Corporation, Richland, Washington.

SGW-48478, 2012, *Interpretation and Integration of Seismic Data in the Gable Gap*, Rev. 1, CH2M HILL Plateau Remediation Company, Richland, Washington.

Tank Side Cesium Removal Demonstration Project, 2019,
https://www.hanford.gov/files.cfm/HAB_TSCR_03-13-19-scs_AJZ.PDF

WA7 89000 8967, 2007, *Hanford Facility Resource Conservation and Recovery Act Permit, Dangerous Waste Portion Revision 8C for the Treatment, Storage, and Disposal of Dangerous Waste*, “Part III, Operating Unit 11 Integrated Disposal Facility Fact Sheet,” State of Washington Department of Ecology, Richland, Washington.

WAC 173-201A, “Water Quality Standards for Surface Waters of the State of Washington,” *Washington Administrative Code*, as amended.

WAC 173-303-665, “Landfills,” *Washington Administrative Code*, as amended.

Waste Isolation Pilot Plant Land Withdrawal Act of 1992, Public Law 102-579, as amended.

WHC-MR-0132, 1990, *A History of the 200 Area Tank Farms*, Westinghouse Hanford Company, Richland, Washington.

WHC-SD-WM-TI-699, 1996, *Technical Basis for Classification of Low-Activity Waste Fraction from Hanford Site Tanks*, Rev. 2, Westinghouse Hanford Company, Richland, Washington.

WSRC-STI-2007-00609, 2007, *Literature Reviews to Support Ion Exchange Technology Selection for Modular Salt Processing*, Washington Savannah River Company, Savannah River Site, Aiken, South Carolina.

APPENDIX A

COMPARISON OF U.S. DEPARTMENT OF ENERGY AND U.S. NUCLEAR REGULATORY COMMISSION LOW-LEVEL WASTE DISPOSAL PERFORMANCE OBJECTIVES AND PERFORMANCE MEASURES

Appendix Purpose

The purpose of this appendix is to show that U.S. Department of Energy (DOE) and U.S. Nuclear Regulatory Commission (NRC) requirements for disposal of low-level waste (LLW) are comparable.

Appendix Content

This appendix identifies applicable DOE performance objectives and measures and the similar NRC performance objectives and discusses their comparability.

Key Points

- Requirements for LLW disposal are embodied in sets of performance objectives and measures for the waste disposal facility.
- The DOE performance objectives and measures are described in DOE M 435.1-1, *Radioactive Waste Management Manual*.
- The NRC performance objectives are described in Subpart C—Performance Objectives of 10 CFR Part 61, “Licensing Requirements for Land Disposal of Radioactive Waste.”
- DOE and NRC performance objectives and measures for LLW disposal are comparable.

TABLE OF CONTENTS

| | | |
|-------------|---|-----|
| A1.0 | INTRODUCTION | A-1 |
| A2.0 | APPLICABLE PERFORMANCE OBJECTIVES AND MEASURES | A-1 |
| A3.0 | COMPARABILITY OF THE GENERAL REQUIREMENTS | A-2 |
| A3.1 | U.S. Department of Energy..... | A-2 |
| A3.2 | U.S. Nuclear Regulatory Commission..... | A-2 |
| A3.3 | Discussion..... | A-2 |
| A4.0 | COMPARABILITY REGARDING PROTECTION OF THE GENERAL POPULATION FROM RELEASES OF RADIOACTIVITY..... | A-3 |
| A4.1 | U.S. Department of Energy..... | A-3 |
| A4.2 | U.S. Nuclear Regulatory Commission..... | A-3 |
| A4.3 | Discussion..... | A-3 |
| A5.0 | COMPARABILITY REGARDING PROTECTION OF INDIVIDUALS FROM INADVERTENT INTRUSION..... | A-4 |
| A5.1 | U.S. Department of Energy..... | A-4 |
| A5.2 | U.S. Nuclear Regulatory Commission..... | A-4 |
| A5.3 | Discussion..... | A-4 |
| A6.0 | COMPARABILITY REGARDING PROTECTION OF INDIVIDUALS DURING OPERATIONS..... | A-5 |
| A6.1 | U.S. Department of Energy..... | A-5 |
| A6.2 | U.S. Nuclear Regulatory Commission..... | A-5 |
| A6.3 | Discussion..... | A-5 |
| A7.0 | COMPARABILITY REGARDING STABILITY OF THE DISPOSAL SITE AFTER CLOSURE..... | A-6 |
| A7.1 | U.S. Department of Energy..... | A-6 |

| | | |
|-------------|---|-----|
| A7.2 | U.S. Nuclear Regulatory Commission..... | A-6 |
| A7.3 | Discussion..... | A-6 |
| A8.0 | REFERENCES | A-7 |

ABBREVIATIONS AND ACRONYMS

| | |
|-------|------------------------------------|
| ALARA | as low as reasonably achievable |
| CFR | <i>Code of Federal Regulations</i> |
| DOE | U.S. Department of Energy |
| LLW | low-level waste |
| NRC | U.S. Nuclear Regulatory Commission |

This page is intentionally left blank.

A1.0 INTRODUCTION

This appendix identifies performance objectives and measures for disposal of low-level waste (LLW) by the U.S. Department of Energy (DOE) and the U.S. Nuclear Regulatory Commission (NRC). It then compares these performance objectives and measures.

Information in this appendix is based in part on previous detailed comparison studies of DOE and NRC performance objectives for LLW disposal (DOE/LLW-225, *Comparison of Selected DOE and Non-DOE Requirements, Standards, and Practices for Low-Level Radioactive Waste Disposal* and WSRC-RP-2001-00341, *Comparison of LLW Disposal Performance Objectives, 10 CFR Part 61 and DOE 435.1*).

A2.0 APPLICABLE PERFORMANCE OBJECTIVES AND MEASURES

DOE M 435.1-1, *Radioactive Waste Management Manual* describes DOE requirements for disposal of LLW. The comparable NRC requirements appear in Title 10, *Code of Federal Regulations* (CFR), Part 61, “Licensing Requirements for Land Disposal of Radioactive Waste”, Subpart C—Performance Objectives, which lists one general requirement and four performance objectives, which are reproduced below.

Section 61.40, “General requirement”

“Land disposal facilities must be sited, designed, operated, closed, and controlled after closure so that reasonable assurance exists that exposures to humans are within the limits established in the performance objectives in §§61.41 through 61.44.”

Section 61.41, “Protection of the general population from releases of radioactivity”

“Concentrations of radioactive material which may be released to the general environment in groundwater, surface water, air, soil, plants, or animals must not result in an annual dose exceeding an equivalent of 25 millirems to the whole body, 75 millirems to the thyroid, and 25 millirems to any other organ of any member of the public. Reasonable effort should be made to maintain releases of radioactivity in effluents to the general environment as low as is reasonably achievable.”

Section 61.42, “Protection of individuals from inadvertent intrusion”

“Design, operation, and closure of the land disposal facility must ensure protection of any individual inadvertently intruding into the disposal site and occupying the site or contacting the waste at any time after active institutional controls over the disposal site are removed.”

Section 61.43, “Protection of individuals during operations”

“Operations at the land disposal facility must be conducted in compliance with the standards for radiation protection set out in part 20 of this chapter, except for releases of radioactivity in effluents from the land disposal facility, which shall be governed by §61.41 of this part. Every reasonable effort shall be made to maintain radiation exposures as low as is reasonably achievable.”

Section 61.44, “Stability of the disposal site after closure”

“The disposal facility must be sited, designed, used, operated, and closed to achieve long-term stability of the disposal site and to eliminate to the extent practicable the need for ongoing active maintenance of the disposal site following closure so that only surveillance, monitoring, or minor custodial care are required.”

A3.0 COMPARABILITY OF THE GENERAL REQUIREMENTS

A3.1 U.S. Department of Energy

The general requirement in DOE M 435.1-1, Chapter IV.P.(1), is expressed as follows:

“Low-level waste disposal facilities shall be sited, designed, operated, maintained, and closed so that a reasonable expectation exists that the following performance objectives will be met for waste disposed of after September 26, 1988”.

A3.2 U.S. Nuclear Regulatory Commission

The NRC regulations in 10 CFR 61.40 provide in relevant part:

“Land disposal facilities must be sited, designed, operated, closed, and controlled after closure so that reasonable assurance exists that exposures to humans are within the limits established in the performance objectives in §§61.41 through 61.44.”

A3.3 Discussion

The statement of NRC requirements in 10 CFR 61.40 is nearly identical to that of the DOE general requirement. The DOE requirement adds the concept of maintenance, which is implicit in the NRC requirement. The DOE requirement does not mention control after closure, but this concept is embodied in the DOE requirements for closure, specifically DOE M 435.1-1, Chapter IV.Q.(2)(c), which requires DOE control until it can be shown that release of the disposal site for unrestricted use will not compromise DOE requirements for radiological protection of the public.

The DOE general requirement for LLW disposal and the NRC general requirement of 10 CFR 61.40 are therefore comparable.

A4.0 COMPARABILITY REGARDING PROTECTION OF THE GENERAL POPULATION FROM RELEASES OF RADIOACTIVITY

A4.1 U.S. Department of Energy

DOE requirements of DOE M 435.1-1, Chapter IV.P.(1), read as follows:

- “(a) Dose to representative members of the public shall not exceed 25 mrem (0.25 mSv) in a year total effective dose equivalent from all exposure pathways, excluding the dose from radon and its progeny in air.
- (b) Dose to representative members of the public via the air pathway shall not exceed 10 mrem (0.10 mSv) in a year total effective dose equivalent, excluding the dose from radon and its progeny.
- (c) Release of radon shall be less than an average flux of 20 pCi/m²/s (0.74 Bq/m²/s) at the surface of the disposal facility. Alternatively, a limit of 0.5 pCi/l (0.0185 Bq/l) of air may be applied at the boundary of the facility.”

A4.2 U.S. Nuclear Regulatory Commission

NRC regulations in 10 CFR 61.41 are expressed as follows:

“Concentrations of radioactive material which may be released to the general environment in groundwater, surface water, air, soil, plants, or animals must not result in an annual dose exceeding an equivalent of 25 millirems to the whole body, 75 millirems to the thyroid, and 25 millirems to any other organ of any member of the public. Reasonable effort should be made to maintain releases of radioactivity in effluents to the general environment as low as is reasonably achievable.”

A4.3 Discussion

DOE uses more current radiation protection methodology, consistent with that used in NRC’s radiation protection standards in NRC’s 10 CFR Part 20, “Standards for Protection Against Radiation.” Because NRC has not revised 10 CFR 61.41 to reflect the more current methodology in 10 CFR Part 20, DOE’s requirements and those in 10 CFR Part 20 differ slightly from those in 10 CFR 61.41. However, the resulting allowable doses are comparable, as NRC has acknowledged (*U.S. Nuclear Regulatory Commission Technical Evaluation Report for the U.S. Department of Energy Savannah River Site Draft Section 3116 Waste Determination for Salt Waste Disposal* [NRC 2005]). NRC has indicated that it expects DOE to use the newer methodology in 10 CFR Part 20 and DOE M 435.1-1. Both NRC and DOE use a performance assessment to assess whether the dose limit will be met.

The DOE requirements go beyond this NRC performance objective by specifying an assessment of the impacts of LLW disposal on water resources [i.e., DOE M 435.1-1, Chapter IV.P.(2)(g)]. The NRC requirement includes maintaining releases to the environment as low as reasonably achievable (ALARA). Although this requirement is not included in the DOE performance objective, it is included in the performance assessment requirements [i.e., DOE M 435.1-1, Chapter IV.P.(2)(f)].

A5.0 COMPARABILITY REGARDING PROTECTION OF INDIVIDUALS FROM INADVERTENT INTRUSION

A5.1 U.S. Department of Energy

DOE requirements of DOE M 435.1-1, Chapter IV.P.(2)(h), for protection of individuals from inadvertent intrusion read as follows:

“For purposes of establishing limits on the concentration of radionuclides that may be disposed of near-surface, the performance assessment shall include an assessment of impacts calculated for a hypothetical person assumed to inadvertently intrude for a temporary period into the low-level waste disposal facility. For intruder analyses, institutional controls shall be assumed to be effective in deterring intrusion for at least 100 years following closure. The intruder analyses shall use performance measures for chronic and acute exposure scenarios, respectively, of 100 mrem (1 mSv) in a year and 500 mrem (5 mSv) total effective dose equivalent excluding radon in air.”

A5.2 U.S. Nuclear Regulatory Commission

NRC requirements of 10 CFR 61.42 are expressed as follows:

“Design, operation, and closure of the land disposal facility must ensure protection of any individual inadvertently intruding into the disposal site and occupying the site or contacting the waste at any time after active institutional controls over the disposal site are removed.”

A5.3 Discussion

The DOE LLW disposal requirement that the performance assessment include an assessment of the impacts on a person inadvertently intruding into the disposal facility is more stringent than the NRC requirement. The NRC waste classification system is based on intruder calculations using a 500 mrem/yr dose limit (NUREG-0945, *Final Environmental Impact Statement on 10 CFR Part 61, “Licensing Requirements for Land Disposal of Radioactive Waste”: Summary and Main Report*, Volume 1). The DOE requirement uses a 100 mrem/yr limit for chronic exposures and a 500 mrem/yr limit for acute exposures.

A6.0 COMPARABILITY REGARDING PROTECTION OF INDIVIDUALS DURING OPERATIONS

A6.1 U.S. Department of Energy

The DOE requirements in DOE M 435.1-1, Chapter I.E.(13), for protection of individual during operations read as follows:

“Radioactive waste management facilities, operations, and activities shall meet the requirements of 10 CFR Part 835, *Occupational Radiation Protection*, and DOE [Order] 5400.5 [now DOE O 458.1], *Radiation Protection of the Public and the Environment*.”

A6.2 U.S. Nuclear Regulatory Commission

The NRC requirements of 10 CFR 61.43 are expressed as follows:

“Operations at the land disposal facility must be conducted in compliance with the standards for radiation protection set out in part 20 of this chapter, except for releases of radioactivity in effluents from the land disposal facility, which shall be governed by §61.41 of this part. Every reasonable effort shall be made to maintain radiation exposures as low as is reasonably achievable.”

A6.3 Discussion

The ALARA concept is an integral part of DOE radiation and environmental protection programs, as expressed in DOE G 441.1-1C, *Radiation Protection Programs Guide for Use with Title 10, Code of Federal Regulations, Part 835, Occupational Radiation Protection*. DOE requirements for occupational radiological protection are addressed in 10 CFR Part 835, “Occupational Radiation Protection” and similar requirements for radiological protection of the public and the environment are addressed in DOE O 458.1. The NRC 10 CFR 61.43 requirement references 10 CFR Part 20, which contains similar radiological protection standards for workers and the public.

Appendix B provides additional information on the comparability of DOE and NRC radiation dose standards that apply to protection of individuals during operations.

A7.0 COMPARABILITY REGARDING STABILITY OF THE DISPOSAL SITE AFTER CLOSURE

A7.1 U.S. Department of Energy

The DOE requirements of DOE M 435.1-1, Chapters IV.Q.(1)(a) and (b) and IV.Q.(2)(c) for stability of the disposal site after closure are expressed as follows:

Disposal Site Stability [DOE M 435.1-1, Chapter IV.Q.(1)(a) and (b)] –
“**Disposal Facility Closure Plans.** A preliminary closure plan shall be developed and submitted to Headquarters for review with the performance assessment and composite analysis. The closure plan shall be updated following issuance of the disposal authorization statement to incorporate conditions specified in the disposal authorization statement. Closure plans shall:

- (a) Be updated as required during the operational life of the facility.
- (b) Include a description of how the disposal facility will be closed to achieve long-term stability and minimize the need for active maintenance following closure and to ensure compliance with the requirements of DOE [Order] 5400.5 [now DOE O 458.1], *Radiation Protection of the Public and the Environment.*”

Disposal Facility Closure [DOE M 435.1-1, Chapter IV.Q.(2)(c)] – “Institutional control measures shall be integrated into land use and stewardship plans and programs, and shall continue until the facility can be released pursuant to DOE [Order] 5400.5 [now DOE O 458.1], *Radiation Protection of the Public and the Environment.*”

A7.2 U.S. Nuclear Regulatory Commission

The NRC requirements of 10 CFR 61.44 state that:

“The disposal facility must be sited, designed, used, operated, and closed to achieve long-term stability of the disposal site and to eliminate to the extent practicable the need for ongoing active maintenance of the disposal site following closure so that only surveillance, monitoring, or minor custodial care are required.”

A7.3 Discussion

The DOE LLW disposal requirements address long-term stability of the site by requiring a description of how closure will achieve stability in the closure plan, and by a description of how closure will minimize the need for active maintenance following closure [DOE M 435.1-1, Chapter IV.Q.(1)(b)]. Additionally, one of the performance assessment requirements [DOE M 435.1-1, Chapter IV.P.(2)(c)] states: “Performance assessments shall address

reasonably foreseeable natural processes that might disrupt barriers against release and transport of radioactive materials.”

A8.0 REFERENCES

10 CFR Part 20, “Standards for Protection Against Radiation”, *Code of Federal Regulations*, as amended.

10 CFR Part 61, “Licensing Requirements for Land Disposal of Radioactive Waste,”
Subpart C—Performance Objectives, *Code of Federal Regulations*, as amended.

10 CFR Part 61, “Licensing Requirements for Land Disposal of Radioactive Waste,”
Subpart C—Performance Objectives, §61.40, “General requirement,” *Code of Federal Regulations*, as amended.

10 CFR Part 61, “Licensing Requirements for Land Disposal of Radioactive Waste,”
Subpart C—Performance Objectives, §61.41, “Protection of the general population from releases of radioactivity,” *Code of Federal Regulations*, as amended.

10 CFR Part 61, “Licensing Requirements for Land Disposal of Radioactive Waste,”
Subpart C—Performance Objectives, §61.42, “Protection of individuals from inadvertent intrusion,” *Code of Federal Regulations*, as amended.

10 CFR Part 61, “Licensing Requirements for Land Disposal of Radioactive Waste,”
Subpart C—Performance Objectives, §61.43, “Protection of individuals during operations,” *Code of Federal Regulations*, as amended.

10 CFR Part 61, “Licensing Requirements for Land Disposal of Radioactive Waste,”
Subpart C—Performance Objectives, §61.44, “Stability of the disposal site after closure,” *Code of Federal Regulations*, as amended.

10 CFR Part 835, “Occupational Radiation Protection”, *Code of Federal Regulations*, as amended.

DOE G 441.1-1C, 2011, *Radiation Protection Programs Guide for Use with Title 10, Code of Federal Regulations, Part 835, Occupational Radiation Protection*, Chg 1, U.S. Department of Energy, Washington, D.C.

DOE/LLW-225, 1995, *Comparison of Selected DOE and Non-DOE Requirements, Standards, and Practices for Low-Level Radioactive Waste Disposal*, Rev. 0, Idaho National Engineering Laboratory, Lockheed Idaho Technologies Company, Idaho Fall, Idaho.

DOE M 435.1-1, 2011, *Radioactive Waste Management Manual*, Change 2, U.S. Department of Energy, Washington, D.C.

DOE O 458.1, 2013, *Radiation Protection of the Public and the Environment*, Admin Chg 3, U.S. Department of Energy, Washington, D.C.

NRC, 2005, *U.S. Nuclear Regulatory Commission Technical Evaluation Report for the U.S. Department of Energy Savannah River Site Draft Section 3116 Waste Determination for Salt Waste Disposal*, U.S. Nuclear Regulatory Commission, Washington, D.C.

NUREG-0945, 1982, *Final Environmental Impact Statement on 10 CFR Part 61 "Licensing Requirements for Land Disposal of Radioactive Waste": Summary and Main Report*, Volume 1, U.S. Nuclear Regulatory Commission, Washington, D.C.

WSRC-RP-2001-00341, 2001, *Comparison of LLW Disposal Performance Objectives, 10 CFR Part 61 and DOE 435.1*, Westinghouse Savannah River Company, Aiken, South Carolina.

APPENDIX B

COMPARABILITY OF U.S. DEPARTMENT OF ENERGY AND U.S. NUCLEAR REGULATORY COMMISSION DOSE STANDARDS DURING OPERATIONS

Appendix Purpose

The purpose of this appendix is to compare U.S. Department of Energy (DOE) and U.S. Nuclear Regulatory Commission (NRC) radiation dose standards that apply to individual workers and to members of the public during operations.

Appendix Content

This appendix identifies applicable DOE dose standards and the similar NRC dose standards and discusses their comparability.

Key Points

- The DOE radiation dose standards appear in 10 CFR Part 835, “Occupational Radiation Protection,” and in DOE Orders.
- The NRC radiation dose standards appear in 10 CFR Part 20, “Standards for Protection Against Radiation.”
- DOE and NRC radiation dose standards are comparable.

TABLE OF CONTENTS

B1.0 INTRODUCTION B-1

B2.0 AIR EMISSIONS LIMIT FOR INDIVIDUAL MEMBER OF THE PUBLIC B-1

B2.1 U.S. Department of Energy..... B-2

B2.2 U.S. Nuclear Regulatory Commission..... B-2

B2.3 Discussion..... B-2

B3.0 TOTAL EFFECTIVE DOSE EQUIVALENT LIMIT FOR ADULT WORKERS B-2

B3.1 U.S. Department of Energy..... B-2

B3.2 U.S. Nuclear Regulatory Commission..... B-3

B3.3 Discussion..... B-3

B4.0 ANY INDIVIDUAL ORGAN OR TISSUE DOSE LIMIT FOR ADULT WORKERS B-3

B4.1 U.S. Department of Energy..... B-3

B4.2 U.S. Nuclear Regulatory Commission..... B-3

B4.3 Discussion..... B-4

B5.0 ANNUAL DOSE LIMIT TO THE LENS OF THE EYE FOR ADULT WORKERS .. B-4

B5.1 U.S. Department of Energy..... B-4

B5.2 U.S. Nuclear Regulatory Commission..... B-4

B5.3 Discussion..... B-4

B6.0 ANNUAL DOSE LIMIT TO THE SKIN OF THE WHOLE BODY AND TO THE SKIN OF THE EXTREMITIES FOR ADULT WORKERS B-4

B6.1 U.S. Department of Energy..... B-4

B6.2 U.S. Nuclear Regulatory Commission..... B-5

B6.3 Discussion..... B-5

| | | |
|--------------|---|-----|
| B7.0 | LIMIT ON SOLUBLE URANIUM INTAKE..... | B-5 |
| B7.1 | U.S. Department of Energy..... | B-5 |
| B7.2 | U.S. Nuclear Regulatory Commission..... | B-5 |
| B7.3 | Discussion..... | B-5 |
| B8.0 | DOSE EQUIVALENT TO AN EMBRYO/FETUS..... | B-6 |
| B8.1 | U.S. Department of Energy..... | B-6 |
| B8.2 | U.S. Nuclear Regulatory Commission..... | B-6 |
| B8.3 | Discussion..... | B-6 |
| B9.0 | DOSE LIMITS FOR INDIVIDUAL MEMBERS OF THE PUBLIC (TOTAL ANNUAL DOSE)..... | B-6 |
| B9.1 | U.S. Department of Energy..... | B-6 |
| B9.2 | U.S. Nuclear Regulatory Commission..... | B-6 |
| B9.3 | Discussion..... | B-7 |
| B10.0 | DOSE LIMITS FOR INDIVIDUAL MEMBERS OF THE PUBLIC (DOSE RATE IN UNRESTRICTED AREAS)..... | B-7 |
| B10.1 | U.S. Department of Energy..... | B-7 |
| B10.2 | U.S. Nuclear Regulatory Commission..... | B-7 |
| B10.3 | Discussion..... | B-8 |
| B11.0 | DOSE LIMITS FOR INDIVIDUAL MEMBERS OF THE PUBLIC WITH ACCESS TO CONTROLLED AREAS..... | B-8 |
| B11.1 | U.S. Department of Energy..... | B-8 |
| B11.2 | U.S. Nuclear Regulatory Commission..... | B-8 |
| B11.3 | Discussion..... | B-8 |
| B12.0 | AS LOW AS REASONABLY ACHIEVABLE..... | B-8 |
| B12.1 | U.S. Department of Energy..... | B-8 |

| | | |
|--------------|---|-----|
| B12.2 | U.S. Nuclear Regulatory Commission..... | B-9 |
| B12.3 | Discussion..... | B-9 |
| B13.0 | REFERENCES | B-9 |

ABBREVIATIONS AND ACRONYMS

| | |
|-------|------------------------------------|
| ALARA | as low as reasonably achievable |
| CFR | <i>Code of Federal Regulations</i> |
| DOE | U.S. Department of Energy |
| NRC | U.S. Nuclear Regulatory Commission |
| ORP | DOE Office of River Protection |
| WIR | Waste Incidental to Reprocessing |

B1.0 INTRODUCTION

The purpose of this appendix is to compare the U.S. Department of Energy (DOE) and U.S. Nuclear Regulatory Commission (NRC) dose standards that apply to protection of the public and the workers from radiation during operations.

Section 5.2.4 of the body of this Draft Waste Incidental to Reprocessing (WIR) Evaluation briefly addressed protection of individuals during operations at the DOE Office of River Protection (ORP) disposal facility. This appendix provides a more detailed treatment of the dose standards used.

Requirements in NRC's regulations at Title 10, *Code of Federal Regulations* (CFR), Part 61, "Licensing Requirements for Land Disposal of Radioactive Waste", Subpart C—Performance Objectives, §61.43, "Protection of individuals during operations" state:

"[O]perations at the land disposal facility must be conducted in compliance with the standards for radiation protection set out in part 20 of this chapter [10 CFR], except for releases of radioactivity in effluents from the land disposal facility, which shall be governed by §61.41 of this part. Every reasonable effort shall be made to maintain radiation exposures as low as is reasonably achievable."

This requirement references 10 CFR Part 20, "Standards for Protection Against Radiation", which contains radiological protection standards for workers and the public. The DOE requirements for occupational radiological protection are provided in 10 CFR Part 835, "Occupational Radiation Protection", and those for radiological protection of the public and the environment are provided in DOE O 458.1, *Radiation Protection of the Public and the Environment*.

The NRC standards for radiation protection in 10 CFR 20 that are considered in detail in this Draft WIR Evaluation are the dose limits for the public and the workers during disposal operations set forth in 10 CFR 20.1101, "Radiation protection programs", item (d); 10 CFR.1201, "Occupational dose limits for adults", items (a)(1)(i), (a)(1)(ii), (a)(2)(i), (a)(2)(ii), and (e); 10 CFR 20.1208, "Dose equivalent to an embryo/fetus" item (a); and 10 CFR 20.1301, "Dose limits for individual members of the public", items (a)(1), (a)(2), and (b).⁷² These NRC dose limits correspond to the DOE dose limits in 10 CFR Part 835 and relevant DOE Orders that establish DOE regulatory and contractual requirements for DOE facilities and activities. As discussed in Section 4.2.6 of this Draft WIR Evaluation, operations will meet these dose limits and doses will be maintained as low as reasonably achievable (ALARA).

B2.0 AIR EMISSIONS LIMIT FOR INDIVIDUAL MEMBER OF THE PUBLIC

⁷² The standards for radiation protection in 10 CFR Part 20 (as cross-referenced in the performance objective in 10 CFR 61.43) which are relevant to this Draft WIR Evaluation are the dose limits for radiation protection of the public and the workers during operations, and not those which address general licensing, administrative, programmatic, or enforcement matters administered by NRC for NRC licensees. Accordingly, this Draft WIR Evaluation addresses in detail the radiation dose limits for the public and the workers during operations that are contained in the provisions of 10 CFR Part 20 referenced above.

B2.1 U.S. Department of Energy

DOE limits doses from air emissions to the public to 10 mrem/yr in DOE O 458.1. The DOE is also subject to and complies with the U.S. Environmental Protection Agency requirement in 40 CFR Part 61, “National Emission Standards for Hazardous Air Pollutants”, Subpart H—National Emission Standards for Emissions of Radionuclides Other Than Radon From Department of Energy Facilities,” §61.92, “Standard”, which has the same limit.⁷³

It is assumed that the individual is an adult living at the site perimeter that is exposed to the maximum yearly radioactive atmospheric release and maximum radiation concentration in food for 365 days per year. For the airborne pathway, the dose is developed by the input of atmospheric release data, vegetation consumption data, milk consumption data, and beef consumption data.

B2.2 U.S. Nuclear Regulatory Commission

The NRC regulation in 10 CFR 20.1101(d) provides in relevant part:

“[A] constraint on air emissions of radioactive material to the environment, excluding Radon-222 and its daughters, shall be established ... such that the individual member of the public likely to receive the highest dose will not be expected to receive a total effective dose equivalent in excess of 10 mrem (0.1 mSv) per year from these emissions.”

B2.3 Discussion

The DOE and NRC requirements are comparable.

B3.0 TOTAL EFFECTIVE DOSE EQUIVALENT LIMIT FOR ADULT WORKERS

B3.1 U.S. Department of Energy

DOE’s regulation in 10 CFR 835.202, “Occupational dose limits for general employees”, item (a)(1) requires that the occupational dose per year for general employees shall not exceed a total effective dose equivalent of 5 rems.

⁷³ 40 CFR 61.92 provides as follows: “Emissions of radionuclides to the ambient air from Department of Energy facilities shall not exceed those amounts that would cause any member of the public to receive in any year an effective dose equivalent of 10 mrem/yr.”

B3.2 U.S. Nuclear Regulatory Commission

The NRC regulation in 10 CFR 20.1201(a), concerning occupational dose limits for adults, provides in relevant part:

“(a) [C]ontrol the occupational dose to individual adults, except for planned special exposures ... to the following dose limits.

(1) An annual limit, which is the more limiting of—

(i) The total effective dose equivalent being equal to 5 rems (0.05 Sv)[.]”

B3.3 Discussion

The DOE and NRC requirements are comparable.

B4.0 ANY INDIVIDUAL ORGAN OR TISSUE DOSE LIMIT FOR ADULT WORKERS

B4.1 U.S. Department of Energy

The DOE regulation in 10 CFR 835.202(a)(2) provides in relevant part:

“... the occupational dose received by general employees shall be controlled such that the following limits are not exceeded in a year:

...

(2) The sum of the equivalent dose to the whole body for external exposures and the committed equivalent dose to any organ or tissue other than the skin or the lens of the eye of 50 rems (0.5 Sv)[.]”

The DOE’s regulations at 10 CFR 835.202(a)(1) and (a)(2) require that the occupational dose per year for general employees shall not exceed both a total effective dose equivalent of 5 rems and the sum of the deep-dose equivalent for external exposures and the committed dose equivalent to any other organ or tissue other than the lens of the eye of 50 rems. The NRC’s regulation specifies that either of these two limits shall be met by NRC licensees, whichever is more limiting. Thus, DOE imposes stricter, separate requirements.

B4.2 U.S. Nuclear Regulatory Commission

The NRC regulation in 10 CFR 20.1201(a) concerning occupational dose limits for adults provides in relevant part:

“(a) [C]ontrol the occupational dose to individual adults, except for planned special exposures ... to the following dose limits.

(1) An annual limit, which is the more limiting of—

...

(ii) The sum of the deep-dose equivalent and the committed dose equivalent to any individual organ or tissue other than the lens of the eye being equal to 50 rems (0.5 Sv).”

B4.3 Discussion

The DOE and NRC requirements are comparable.

B5.0 ANNUAL DOSE LIMIT TO THE LENS OF THE EYE FOR ADULT WORKERS

B5.1 U.S. Department of Energy

The DOE regulation in 10 CFR 835.202(a)(3) provides in relevant part:

“... the occupational dose received by general employees shall be controlled such that the following limits are not exceeded in a year:

(3) An equivalent dose to the lens of the eye of 15 rems (0.15 Sv)[.]”

B5.2 U.S. Nuclear Regulatory Commission

The NRC regulation in 10 CFR 20.1201(a), concerning occupational dose limits for adults, provides in relevant part:

“(a) [C]ontrol the occupational dose to individual adults, except for planned special exposures ... to the following dose limits.

...

(2) The annual limits to the lens of the eye, to the skin of the whole body, and to the skin of the extremities, which are:

(i) A lens dose equivalent of 15 rems (0.15 Sv)[.]”

B5.3 Discussion

The DOE and NRC requirements are comparable.

B6.0 ANNUAL DOSE LIMIT TO THE SKIN OF THE WHOLE BODY AND TO THE SKIN OF THE EXTREMITIES FOR ADULT WORKERS

B6.1 U.S. Department of Energy

The DOE regulation in 10 CFR 835.202(a)(4) provides in relevant part:

“... the occupational dose received by general employees shall be controlled such that the following limits are not exceeded in a year:

...

(4) The sum of the equivalent dose to the skin or to any extremity for external exposures and the committed equivalent dose to the skin or to any extremity of 50 rems (0.5 Sv).”

B6.2 U.S. Nuclear Regulatory Commission

The NRC regulation in 10 CFR 20.1201(a) concerning occupational dose limits for adults provides in relevant part:

“(a) [C]ontrol the occupational dose to individual adults, except for planned special exposures ... to the following dose limits.

...

(2) The annual limits to the lens of the eye, to the skin of the whole body, and to the skin of the extremities, which are:

...

(ii) A shallow-dose equivalent of 50 rem (0.5 Sv) to the skin of the whole body or to the skin of any extremity.”

B6.3 Discussion

The DOE and NRC requirements are comparable.

B7.0 LIMIT ON SOLUBLE URANIUM INTAKE

B7.1 U.S. Department of Energy

Requirements in DOE O 440.1B, *Worker Protection Program for DOE (Including the National Nuclear Security Administration) Federal Employees* for soluble uranium intake are the more restrictive of the concentrations in the American Conference of Governmental Industrial Hygienists threshold limit values (0.2 mg/m³, which is the same as noted in 10 CFR Part 20, Appendix B) or the Occupational Safety and Health Administration permissible exposure limit (0.05 mg/m³). The permissible exposure limit for soluble uranium, which equates to a soluble uranium intake of 2.4 mg/week, is the more restrictive of the two.

B7.2 U.S. Nuclear Regulatory Commission

The NRC regulation in 10 CFR 20.1201(e) concerning occupational dose limits for adults provides in relevant part: “In addition to the annual dose limits,... limit the soluble uranium intake by an individual to 10 milligrams in a week in consideration of chemical toxicity”.

B7.3 Discussion

The DOE requirements are more restrictive.

B8.0 DOSE EQUIVALENT TO AN EMBRYO/FETUS

B8.1 U.S. Department of Energy

The DOE regulation in 10 CFR 835.206, “Limits for the embryo/fetus”, item (a) provides in relevant part:

“The equivalent dose limit for the embryo/fetus from the period of conception to birth, as a result of occupational exposure of a declared pregnant worker, is 0.5 rem (0.005 Sv).”

After declaration of pregnancy, DOE provides the option of a mutually agreeable assignment of work tasks, without loss of pay or promotional opportunity, such that further occupational radiation exposure during the remainder of the gestation period is unlikely. In addition, personnel dosimetry⁷⁴ is provided and used to track exposure carefully.

B8.2 U.S. Nuclear Regulatory Commission

The NRC regulation in 10 CFR 20.1208(a) concerning the dose equivalent to an embryo/fetus provides in relevant part:

“... ensure that the dose equivalent to the embryo/fetus during the entire pregnancy, due to the occupational exposure of a declared pregnant woman, does not exceed 0.5 rem (5 mSv).”

B8.3 Discussion

The DOE and NRC requirements are comparable.

B9.0 DOSE LIMITS FOR INDIVIDUAL MEMBERS OF THE PUBLIC (TOTAL ANNUAL DOSE)

B9.1 U.S. Department of Energy

Provisions in DOE O 458.1 limit public doses to 0.1 rem/yr.

B9.2 U.S. Nuclear Regulatory Commission

The NRC regulation in 10 CFR 20.1301(a) concerning dose limits for individual members of the public provides in relevant part:

“(a) [C]onduct operations so that—

⁷⁴ The term dosimetry or personnel dosimetry refers to a device carried or worn by an individual working near radiation for measuring the amount of radiation to which he or she is exposed.

(1) The total effective dose equivalent to individual members of the public ... does not exceed 0.1 rem (1 mSv) in a year, exclusive of the dose contributions from background radiation, from any medical administration the individual has received, from exposure to individuals administered radioactive material and released..., from voluntary participation in medical research programs, and from the ... disposal of radioactive material into sanitary sewerage[.]”

B9.3 Discussion

The DOE and NRC requirements are comparable.

B10.0 DOSE LIMITS FOR INDIVIDUAL MEMBERS OF THE PUBLIC (DOSE RATE IN UNRESTRICTED AREAS)

B10.1 U.S. Department of Energy

DOE’s regulation in 10 CFR 835.602, “Controlled areas” establishes the expectation that the total effective dose equivalent in controlled areas will be less than 0.1 rem/yr. In accordance with 10 CFR 835.602, radioactive material areas have been established for accumulations of radioactive material within controlled areas that could result in a radiation dose of 100 mrem/yr or greater. Averaged over a work year, this yields a constant average dose rate of 0.00005 rem/hr. In addition, training and dosimetry are required for individual members of the public for entry into controlled areas, as well as signs at each access point to a controlled area.

B10.2 U.S. Nuclear Regulatory Commission

The NRC regulation in 10 CFR 20.1301(a) concerning dose limits for individual members of the public provides in relevant part:

“(a) [C]onduct operations so that—

(1) The total effective dose equivalent to individual members of the public from the licensed operation does not exceed 0.1 rem (1 mSv) in a year, exclusive of the dose contributions from background radiation, from any medical administration the individual has received, from exposure to individuals administered radioactive material and released under §35.75, from voluntary participation in medical research programs, and from the licensee’s disposal of radioactive material into sanitary sewerage in accordance with §20.2003, and

(2) The dose in any unrestricted area from external sources, exclusive of the dose contributions from patients administered radioactive material and released in accordance with §35.75, does not exceed 0.002 rem (0.02 millisievert) in any one hour.

(b) If the licensee permits members of the public to have access to controlled areas, the limits for members of the public continue to apply to those individuals.”

B10.3 Discussion

The DOE and NRC requirements are comparable.

B11.0 DOSE LIMITS FOR INDIVIDUAL MEMBERS OF THE PUBLIC WITH ACCESS TO CONTROLLED AREAS

B11.1 U.S. Department of Energy

The DOE regulation in 10 CFR 835.208, “Limits for members of the public entering a controlled area” provides:

“The total effective dose limit for members of the public exposed to radiation and/or radioactive material during access to a controlled area is 0.1 rem (0.001 Sv) in a year.”

DOE requires training for individual members of the public before entry into controlled areas. In addition, to ensure no member of the public exceeds radiation exposure limits, use of dosimetry is required if a member of the public is expected to enter a controlled area and receive a dose that may exceed 0.05 rem in a year.

B11.2 U.S. Nuclear Regulatory Commission

The NRC regulation in 10 CFR 20.1301(b) concerning dose limits for individual members of the public provides in relevant part:

“[I]f ... members of the public [are permitted] to have access to controlled areas, the limits for members of the public [0.1 rem (1 mSv)] continue to apply to those individuals.”

B11.3 Discussion

The DOE and NRC requirements in this area are comparable.

B12.0 AS LOW AS REASONABLY ACHIEVABLE

B12.1 U.S. Department of Energy

The DOE regulation in 10 CFR 835.2, “Definitions” defines ALARA as “the approach to radiation protection to manage and control exposures (both individual and collective) to the work force and to the general public to as low as is reasonable, taking into account social, technical, economic, practical, and public policy considerations.” The DOE regulation in 10 CFR 835.2 also specifies: “ALARA is not a dose limit but a process which has the objective of attaining doses as far below the applicable limits ... as is reasonably achievable.”

B12.2 U.S. Nuclear Regulatory Commission

The NRC regulation in 10 CFR 20.1003, “Definitions” defines ALARA in relevant part: “ALARA ... means making every reasonable effort to maintain exposures to radiation as far below the dose limits ... as is practical consistent with the purpose for which the ... activity is undertaken”.

B12.3 Discussion

The DOE and NRC definitions of ALARA are comparable.

B13.0 REFERENCES

10 CFR Part 20, “Standards for Protection Against Radiation,” *Code of Federal Regulations*, as amended.

10 CFR Part 20, “Standards for Protection Against Radiation,” Subpart A—General Provisions, §20.1003, “Definitions,” *Code of Federal Regulations*, as amended.

10 CFR Part 20, “Standards for Protection Against Radiation,” Subpart B—Radiation Protection Programs, §20.1101, “Radiation protection programs,” *Code of Federal Regulations*, as amended.

10 CFR Part 20, “Standards for Protection Against Radiation,” Subpart C—Occupational Dose Limits, §20.1201, “Occupational dose limits for adults,” *Code of Federal Regulations*, as amended.

10 CFR Part 20, “Standards for Protection Against Radiation,” Subpart C—Occupational Dose Limits, §20.1208, “Dose equivalent to an embryo/fetus,” *Code of Federal Regulations*, as amended.

10 CFR Part 20, “Standards for Protection Against Radiation,” Subpart D—Radiation Dose Limits for Individual Members of the Public, §20.1301, “Dose limits for individual members of the public,” *Code of Federal Regulations*, as amended.

10 CFR Part 61, “Licensing Requirements for land disposal of radioactive waste,” *Code of Federal Regulations*, as amended.

10 CFR Part 61, “Licensing Requirements for Land Disposal of Radioactive Waste,” Subpart C—Performance Objectives, §61.43, “Protection of individuals during operations,” *Code of Federal Regulations*, as amended.

10 CFR Part 835, “Occupational Radiation Protection,” *Code of Federal Regulations*, as amended.

10 CFR Part 835, “Occupational Radiation Protection,” Subpart A—General Provisions, §835.2, “Definitions,” *Code of Federal Regulations*, as amended.

- 10 CFR Part 835, “Occupational Radiation Protection,” Subpart C—Standards for Internal and External Exposure, §835.202, “Occupational dose limits for general employees,” *Code of Federal Regulations*, as amended.
- 10 CFR Part 835, “Occupational Radiation Protection,” Subpart C—Standards for Internal and External Exposure, §835.206, “Limits for the embryo/fetus,” *Code of Federal Regulations*, as amended.
- 10 CFR Part 835, “Occupational Radiation Protection,” Subpart C—Standards for Internal and External Exposure, §835.208, “Limits for members of the public entering a controlled area,” *Code of Federal Regulations*, as amended.
- 10 CFR Part 835, “Occupational Radiation Protection,” Subpart G—Posting and Labeling, §835.602, “Controlled areas,” *Code of Federal Regulations*, as amended.
- 40 CFR Part 61, “National Emission Standards for Hazardous Air Pollutants,” *Code of Federal Regulations*, as amended.
- 40 CFR Part 61, “National Emission Standards for Hazardous Air Pollutants,” Subpart H—National Emission Standards for Emissions of Radionuclides Other Than Radon From Department of Energy Facilities, §61.92, “Standard,” *Code of Federal Regulations*, as amended.
- DOE O 440.1B, 2013, *Worker Protection Program for DOE (Including the National Nuclear Security Administration) Federal Employees*, Chg 2 (AdminChg), U.S. Department of Energy, Washington, D.C.
- DOE O 458.1, 2013, *Radiation Protection of the Public and the Environment*, Admin Chg 3, U.S. Department of Energy, Washington, D.C.

APPENDIX C

CONSIDERATION OF THE CRITERIA IN SECTION 3116 OF THE RONALD W. REAGAN NATIONAL DEFENSE AUTHORIZATION ACT FOR FISCAL YEAR 2005

Appendix Purpose

The purpose of this appendix is to discuss the criteria in Section 3116 of the *Ronald W. Reagan National Defense Authorization Act for Fiscal Year 2005* with respect to this Draft WIR Evaluation.

Appendix Content

This appendix describes the subject criteria in relation to VLAW.

Key Points

- Section 3116 of the *Ronald W. Reagan National Defense Authorization Act for Fiscal Year 2005* does not apply to Hanford waste.
- However, the VLAW would be consistent with the criteria of Section 3116 of the *Ronald W. Reagan National Defense Authorization Act for Fiscal Year 2005*.

TABLE OF CONTENTS

| | | |
|-------------|--|-----|
| C1.0 | INTRODUCTION | C-1 |
| C2.0 | CONSIDERATION OF WHETHER THE VITRIFIED LOW-ACTIVITY WASTE REQUIRES PERMANENT ISOLATION IN A DEEP GEOLOGIC REPOSITORY .. | C-2 |
| C2.1 | Consideration of Removal of Highly Radioactive Radionuclides | C-3 |
| C2.2 | Consideration of Radionuclide Concentration Limits, Waste Disposal Performance Objectives, and State-approved Closure Plan or State-issued Permit..... | C-4 |
| C2.3 | Consultation with U.S. Nuclear Regulatory Commission | C-4 |
| C3.0 | REFERENCES | C-4 |

ABBREVIATIONS AND ACRONYMS

| | |
|-------|------------------------------------|
| CFR | <i>Code of Federal Regulations</i> |
| DFLAW | Direct-Feed Low-Activity Waste |
| DOE | U.S. Department of Energy |
| IDF | Integrated Disposal Facility |
| ILAW | immobilized low-activity waste |
| LLW | low-level waste |
| NRC | U.S. Nuclear Regulatory Commission |
| VLAW | vitified low-activity waste |
| WIR | Waste Incidental to Reprocessing |

C1.0 INTRODUCTION

Sections 4 through 6 of this Draft Waste Incidental to Reprocessing (WIR) Evaluation demonstrate that the vitrified low-activity waste (VLAW) meets the criteria of DOE M 435.1-1, *Radioactive Waste Management Manual* for determining that the waste is incidental to reprocessing, is not high-level radioactive waste, and may be managed and disposed of as low-level waste (LLW) under U.S. Department of Energy (DOE)'s regulatory authority pursuant to the *Atomic Energy Act of 1954*, as amended. Section 3116 of the *Ronald W. Reagan National Defense Authorization Act for Fiscal Year 2005* contains similar criteria, and provides that the Secretary of Energy, in consultation with the U.S. Nuclear Regulatory Commission (NRC), may determine that waste resulting from reprocessing of spent nuclear fuel at DOE facilities in South Carolina and Idaho, that is to be disposed of within those States, is not high-level radioactive waste where the criteria in Section 3116(a)(1)-(3) are met.⁷⁵

Although Section 3116 of the *Ronald W. Reagan National Defense Authorization Act for Fiscal Year 2005* does not apply to the Hanford waste,⁷⁶ the following discussion addresses the relevant

⁷⁵ The criteria appear in Subsection (a) of Section 3116. Section 3116(a) provides:

“(a) IN GENERAL.—Notwithstanding the provisions of the Nuclear Waste Policy Act of 1982, the requirements of section 202 of the Energy Reorganization Act of 1974, and other laws that define classes of radioactive waste, with respect to material stored at a Department of Energy site at which activities are regulated by a covered State pursuant to approved closure plans or permits issued by the State, the term "high-level radioactive waste" does not include radioactive waste resulting from the reprocessing of spent nuclear fuel that the Secretary of Energy (in this section referred to as the "Secretary"), in consultation with the Nuclear Regulatory Commission (in this section referred to as the "Commission"), determines—

(1) does not require permanent isolation in a deep geologic repository for spent fuel or high-level radioactive waste;

(2) has had highly radioactive radionuclides removed to the maximum extent practical; and

(3)(A) does not exceed concentration limits for Class C low-level waste as set out in Section 61.55 of title 10, Code of Federal Regulations, and will be disposed of—

(i) in compliance with the performance objectives set out in subpart C of part 61 of title 10, Code of Federal Regulations; and

(ii) pursuant to a State-approved closure plan or State-issued permit, authority for the approval or issuance of which is conferred on the State outside of this section; or

(B) exceeds concentration limits for Class C low-level waste as set out in section 61.55 of title 10, Code of Federal Regulations, but will be disposed of—

(i) in compliance with the performance objectives set out in subpart C of part 61 of title 10, Code of Federal Regulations;

(ii) pursuant to a State-approved closure plan or State-issued permit, authority for the approval or issuance of which is conferred on the State outside of this section; and

(iii) pursuant to plans developed by the Secretary in consultation with the Commission.”

Subsection (b) of Section 3116 addresses monitoring by NRC. Subsection (c) addresses inapplicability to certain materials (i.e., materials transported from the covered State). Subsection (d) identifies the covered States (South Carolina and Idaho). Subsection (e) addresses certain matters concerning construction of Section 3116, and provides that the section does not establish any precedent in any State other than South Carolina and Idaho. Subsection (f) provides for judicial review of determinations made pursuant to Section 3116 and of any failure by NRC to carry out its monitoring responsibilities.

⁷⁶ That Section 3116(a) applies only to waste from reprocessing at DOE facilities in South Carolina and Idaho, which is to be disposed of in those states, is made clear by the language used, which includes the following:

“(c) INAPPLICABILITY TO CERTAIN MATERIALS.—Subsection (a) shall not apply to any material otherwise covered by that subsection that is transported from the covered State.

criteria in 3116(a)(1)-(3) for perspective and information, and, because it may be of interest to stakeholders, shows that pretreatment using the Direct-Feed Low-Activity Waste (DFLAW) approach, and vitrification and disposal of the VLAW, would be consistent with relevant criteria in Section 3116(a)(1)-(3) of the *Ronald W. Reagan National Defense Authorization Act for Fiscal Year 2005*.

C2.0 CONSIDERATION OF WHETHER THE VITRIFIED LOW-ACTIVITY WASTE REQUIRES PERMANENT ISOLATION IN A DEEP GEOLOGIC REPOSITORY

The first criterion or clause in Section 3116(a), as set forth in Section 3116(a)(1), provides that the waste “does not require permanent isolation in a deep geologic repository for spent fuel or high-level radioactive waste.” DOE M 435.1-1 does not contain an identical consideration, but similarly provides in relevant part in Chapter II.B.(2)(a) that the waste “[w]ill be managed as low-level waste” and meet the criteria in Chapter II.B.(2)(a).

With respect to the first criterion or clause, as provided in Section 3116(a)(1), the DOE, in consultation with the NRC, has explained:

“Clause (1), noted above, is a broader criterion for the Secretary, in consultation with the NRC, to consider whether, notwithstanding that waste from reprocessing meets the other two criteria, there are other considerations that, in the Secretary’s judgment, require its disposal in a deep geologic repository. Generally, such considerations would be an unusual case because waste that meets the third criterion would be waste that will be disposed of in a manner that meets the 10 CFR Part 61, Subpart C performance objectives and either falls within one of the classes set out in 10 CFR 61.55 that the NRC has specified are considered “generally acceptable for near-surface disposal” or for which the Secretary has consulted with NRC concerning DOE’s disposal plans. As the NRC explained in *In the Matter of Louisiana Energy Services, L.P. (National Enrichment Services)* (CLI-05-05, 2005), the 10 CFR Part 61, Subpart C performance objectives in turn “set forth the ultimate standards and radiation limits for (1) protection of the general population from releases of radioactivity; (2) protection of individuals from inadvertent intrusion; (3) protection of individuals during operations; and (4) stability of the disposal site after closure.” It follows that if disposal of a waste stream in a facility that is not a deep geologic repository will meet these objectives, in the ordinary case that waste stream does not “require disposal in a deep geologic repository” because non-repository disposal will be protective of public health and safety.

It is possible that in rare circumstances a waste stream that meets the third criterion might have some other unique radiological characteristic or may raise unique policy considerations that warrant its disposal in a deep geologic repository. Clause (1) is an

(d) COVERED STATES.—For purposes of this section, the following States are covered States:

(1) the State of South Carolina.

(2) the State of Idaho.

(e) CONSTRUCTION.— ...

(2) Nothing in this section establishes any precedent or is binding on the State of Washington, the State of Oregon, or any other State not covered by subsection (d) for the management, storage, treatment, and disposition of radioactive and hazardous materials.”

acknowledgement by Congress of that possibility. For example, the waste stream could contain material that, while not presenting a health and safety danger if disposed of at near- or intermediate-surface, nevertheless presents non-proliferation risks that the Secretary concludes cannot be adequately guarded against absent deep geologic disposal. Clause (1) gives the Secretary, in consultation with NRC, the authority to consider such factors in determining whether waste that meets the other two criteria needs disposal in a deep geologic repository in light of such considerations.”⁷⁷

That is not the case here. As demonstrated in Section 4 of this Draft WIR Evaluation, key radionuclides will have been removed from the tank waste to the maximum extent technically and economically practical. Moreover, the resulting waste will be in a solid physical form and will not exceed the concentration limits for Class C LLW in Title 10, *Code of Federal Regulations* (CFR), Part 61, “Licensing Requirements for Land Disposal of Radioactive Waste”, Subpart D—Technical Requirements for Land Disposal Facilities, §61.55, “Waste classification”, as described in Section 6. As explained in Section 5, disposal of VLAW as LLW at Hanford also would meet safety requirements comparable to the NRC performance objectives in 10 CFR Part 61, Subpart C—Performance Objectives, so as to provide for the protection of human health and safety and the environment. As such, the VLAW does not present a danger to human health and safety, such that disposal in a deep geologic repository would be warranted. Furthermore, this LLW does not present unique radiological characteristics, or raise non-proliferation risks or other unique policy considerations, which, while not manifesting a danger to human health, nevertheless would command deep geologic disposal. Accordingly, this disposal of this waste at Hanford as LLW meets DOE criteria and would be consistent with the first criterion of Section 3116(a).

C2.1 Consideration of Removal of Highly Radioactive Radionuclides

The second criterion of Section 3116(a) specifies that the waste “has had highly radioactive radionuclides removed to the maximum extent practical”. DOE M 435.1-1, Chapter II.B.(2)(a)1, contains a similar provision, which specifies that such wastes “[h]ave been processed, or will be processed, to remove key radionuclides to the maximum extent that is technically and economically practical”.⁷⁸

Section 4 of this Draft WIR Evaluation identifies the key radionuclides in VLAW. As can be seen in this section, all radionuclides in Tables 1 and 2 of 10 CFR 61.55 were considered. Furthermore, Section 4 of this Draft WIR Evaluation describes how key radionuclides will have been removed to the maximum extent technically and economically practical, thus satisfying the DOE criterion and evincing consistency with the second criterion of Section 3116(a).

⁷⁷ DOE/NE-ID-11226, *Basis for Section 3116 Determination for the Idaho Nuclear Technology and Engineering Center Tank Farm Facility*.

⁷⁸ In this regard, NRC staff considers key radionuclides and highly-radioactive radionuclides – which are those radionuclides that contribute most significantly to risk to the public, workers, and the environment – to be equivalent for the purpose of evaluating waste determinations (NUREG-1854, *NRC Staff Guidance for Activities Related to U.S. Department of Energy Waste Determinations – Draft Final Report for Interim Use*).

C2.2 Consideration of Radionuclide Concentration Limits, Waste Disposal Performance Objectives, and State-approved Closure Plan or State-issued Permit

The third criterion in Section 3116(a)(3) concerns whether the waste does not exceed concentration limits for Class C LLW in 10 CFR 61.55 and whether the waste will be disposed of in accordance with the performance objectives at 10 CFR Part 61, Subpart C and the State-approved Closure Plan. The criteria in DOE M 435.1-1, Chapter II.B.(2)(a)2 and (a)3 similarly provide that waste “[w]ill be managed to meet safety requirements comparable to the performance objectives set out in 10 CFR Part 61, Subpart C” and “will be incorporated in a solid physical form at a concentration that does not exceed the applicable concentration limits for Class C low-level waste as set out in 10 CFR 61.55”, respectively. Section 5 of this Draft WIR Evaluation demonstrates that disposal of VLAW at the Integrated Disposal Facility (IDF) will meet the safety requirements comparable to the performance objectives set out in 10 CFR Part 61, Subpart C. Section 6 of this Draft WIR Evaluation demonstrates that the VLAW glass does not exceed the Class C concentration limits in 10 CFR 61.55. Section 1.3 of this Draft WIR Evaluation identifies that operation of the IDF, where the VLAW will be disposed, will be permitted by the State of Washington Department of Ecology. Therefore, disposal of VLAW at the IDF would be consistent with the third criteria of Section 3116(a).

C2.3 Consultation with U.S. Nuclear Regulatory Commission

Section 3116(a) also provides for consultation with the NRC. As explained previously, DOE is consulting with NRC concerning this Draft WIR Evaluation, as well as making this draft evaluation available for State, Tribal Nation and public comment. DOE will consider NRC comments, as well as comments from the public and other stakeholders, before finalizing the evaluation and before making any final determination as to whether the VLAW is or is not high-level radioactive waste. Accordingly, such consultation is consistent with the provision for NRC consultation in Section 3116 (a) of the *Ronald W. Reagan National Defense Authorization Act for Fiscal Year 2005*.

C3.0 REFERENCES

Atomic Energy Act of 1954, 42 USC 2011, et seq., as amended.

10 CFR Part 61, “Licensing Requirements for Land Disposal of Radioactive Waste,” Subpart C—Performance Objectives, *Code of Federal Regulations*, as amended.

10 CFR Part 61.55, “Licensing Requirements for Land Disposal of Radioactive Waste,” Subpart D—Technical Requirements for Land Disposal Facilities, §61.55, “Waste classification,” *Code of Federal Regulations*, as amended.

DOE M 435.1-1, 2007, *Radioactive Waste Management Manual*, Change 1, U.S. Department of Energy, Washington, D.C.

CLI-05-05, 2005, In the Matter of Louisiana Energy Services, L.P. (National Enrichment Services), Docket No. 70-3103-ML, U.S. Nuclear Regulatory Commission, Washington, D.C. (January 18, 2005).

DOE/NE-ID-11226, 2006, *Basis for Section 3116 Determination for the Idaho Nuclear Technology and Engineering Center Tank Farm Facility*, Rev. 0, Idaho National Laboratory, Idaho.

NUREG-1854, 2007, *NRC Staff Guidance for Activities Related to U.S. Department of Energy Waste Determinations – Draft Final Report for Interim Use*, U.S. Nuclear Regulatory Commission, Office of Federal and State Materials and Environmental Management Programs, Washington, D.C.

Ronald W. Reagan National Defense Authorization Act for Fiscal Year 2005, Public Law 108-375.

This page is intentionally left blank.

APPENDIX D

U.S. NUCLEAR REGULATORY COMMISSION AND HANFORD INTERACTION HISTORY

Appendix Purpose

The purpose of this appendix is to discuss the background of prior interfaces between DOE and NRC with respect to this Draft WIR Evaluation.

Appendix Content

This appendix describes NRC/DOE historical interaction.

TABLE OF CONTENTS

| | | |
|------|--|------|
| D1.0 | U.S. NUCLEAR REGULATORY COMMISSION AND HANFORD INTERACTION HISTORY | D-1 |
| D2.0 | U.S. NUCLEAR REGULATORY COMMISSION CONDITIONS | D-4 |
| D2.1 | U.S. Nuclear Regulatory Commission Condition 1..... | D-4 |
| D2.2 | U.S. Nuclear Regulatory Commission Condition 2..... | D-5 |
| D2.3 | U.S. Nuclear Regulatory Commission Condition 3..... | D-5 |
| D3.0 | U.S. NUCLEAR REGULATORY COMMISSION PROVISIONAL AGREEMENT REFERENCE..... | D-6 |
| D4.0 | REFERENCES | D-10 |

FIGURES

| | | |
|-------------|---|-----|
| Figure D-1. | U.S. Nuclear Regulatory Commission Provisional Agreement..... | D-2 |
|-------------|---|-----|

ABBREVIATIONS AND ACRONYMS

| | |
|--------|--|
| CFR | <i>Code of Federal Regulations</i> |
| DOE | U.S. Department of Energy |
| DST | double-shell tank |
| HFFACO | <i>Hanford Federal Facility Agreement and Consent Order</i> |
| HLW | high-level radioactive waste |
| ILAW | immobilized low-activity waste |
| LAW | low-activity waste |
| LLW | low-level radioactive waste |
| NRC | U.S. Nuclear Regulatory Commission |
| PUREX | Plutonium Uranium Extraction (plant) |
| SST | single-shell tank |
| TBR | WHC-SD-WM-TI-699, <i>Technical Basis for Classification of Low-Activity Waste Fraction from Hanford Site Tanks</i> |
| TRU | transuranic |
| VLAW | vitrified low-activity waste |

D1.0 U.S. NUCLEAR REGULATORY COMMISSION AND HANFORD INTERACTION HISTORY

The U.S. Department of Energy (DOE)'s initial request for concurrence from the U.S. Nuclear Regulatory Commission (NRC) that treated Hanford tank waste is incidental to reprocessing and does not require NRC licensing as high-level radioactive waste (HLW) occurred between 1988 and 1989. This request was based on the preferred alternative in DOE/EIS-0113, *Final Environmental Impact Statement, Disposal of Hanford Defense High-Level, Transuranic and Tank Wastes, Hanford Site, Richland, Washington*, under which DOE would separate low-activity and high-level waste from the double-shell tanks (DSTs), grout the low-activity portion of the waste, and dispose of the grouted waste in large, onsite vaults. A radionuclide material balance was submitted to NRC from DOE showing that it could remove at least 95% of the total radioactivity by removing ¹³⁷Cs, ⁹⁰Sr, and transuranic (TRU) constituents using proven separations processes such as settle/decant, filtration, and ion exchange⁷⁹. NRC agreed that the criteria DOE used for classification of grout feed as low-level waste were appropriate and consequently that the grout facility for disposal of DST waste (containing only 3% to 5% of the original inventories of these key radionuclides) would not be subject to NRC licensing authority.

As a result, the States of Washington and Oregon and the Yakima Tribes petitioned the NRC to amend Title 10, *Code of Federal Regulations* (CFR), Part 50, "Domestic Licensing of Production and Utilization Facilities" to add clarifying language that all Hanford DST waste is HLW. This petition was denied in 1993 based on the NRC's understanding that DOE will assure that the treated waste will meet the following three criteria:

1. Has been processed to remove key radionuclides to the maximum extent technically and economically practical
2. Will be incorporated in a solid physical form that does not exceed the applicable concentration limits for Class C low-level radioactive waste (LLW) set out in 10 CFR Part 61, "Licensing Requirements for Land Disposal of Radioactive Waste", Subpart D—Technical Requirements for Land Disposal Facilities, §61.55, "Waste classification" and
3. Will be managed so that safety requirements comparable to the performance objectives set out in 10 CFR Part 61 are satisfied.

By 1997, DOE's plans shifted to include treatment of both single-shell tank (SST) and DST waste based on the preferred option from DOE/EIS-0189, *Tank Waste Remediation System, Hanford Site, Richland, Washington, Final Environmental Impact Statement* as documented in 62 FR 8693, "Record of Decision for the Tank Waste Remediation System, Hanford Site, Richland, WA." The tank wastes would be separated by activity and the low-activity portion would be vitrified and disposed of onsite. DOE again requested NRC's concurrence that the low-activity waste (LAW) portion meets Criteria 1 based on the previous 1993 agreement specifying that "wastes have been processed to remove key radionuclides to the maximum extent that is technically and economically practical" and is therefore incidental to reprocessing.

⁷⁹ The Plutonium Uranium Extraction (PUREX) plant, waste management and planned B Plant pretreatment flowsheets were used to estimate the partitioning of radionuclides between the low-activity and high level feeds.

In support of this request, DOE submitted WHC-SD-WM-TI-699, *Technical Basis for Classification of Low-Activity Waste Fraction from Hanford Site Tanks* (the TBR) to the NRC for review. The TBR evaluated available separation technologies for the removal of what were then identified as key radionuclides (^{137}Cs , ^{90}Sr , ^{79}Se , TRU, ^{99}Tc , ^{14}C , ^{129}I , ^3H , and uranium). Separation processes deemed to be both technically and economically practical included simple solids-liquid separations for the removal of ^{90}Sr and TRU constituents followed by an ion-exchange process for the removal of ^{137}Cs . Combined, these processes were estimated to result in approximately 8.5 MCi (~ 2%) of activity remaining in the low-activity portion of the waste. Based on this potential remaining activity, the NRC stated: “It is considered that Criterion One for classifying the Hanford site LAW fraction as incidental waste will be met if the waste management plan presented in the Technical Basis report is followed. Note that if actual radionuclide inventories, either in the tanks or following separation, are significantly higher than or different in character from those projected, compliance with this criterion will require re-evaluation by NRC.” (“Classification of Hanford Low-Activity Waste Fraction” [NRC 1997]).

Beginning in the late 1980s, several interactions occurred between DOE and NRC staff about classification of the vitrified low-activity waste (VLAW) that eventually led to provisional agreement by the NRC in 1997 (Figure D-1) that the disposal of VLAW would not be subject to NRC licensing – that is, it would not be HLW – if certain conditions were met. During this period, DOE worked with the NRC to develop a method to classify the predominantly chemical fraction of the Hanford tank waste (i.e., the LAW) as LLW once most key radionuclides had been removed. Meetings were held and correspondence exchanged. A description of the interactions between DOE and NRC on this matter follows.

Figure D-1. U.S. Nuclear Regulatory Commission Provisional Agreement.



In 1989, DOE requested NRC’s concurrence that LAW from DSTs⁸⁰ to be disposed of onsite by grouting in near-surface concrete vaults would be properly classified in the grouted waste form as LLW and not as HLW, and therefore would not be subject to NRC licensing authority (Letter to R. M. Bernero, NRC [Rizzo 1989]). While this matter was pending before the NRC, the States of Washington and Oregon and the Yakama Nation filed a petition with the NRC for formal rulemaking concerning “the process and criteria for classifying radioactive waste materials at defense facilities as high-level radioactive waste (HLW) or as non-HLW”

⁸⁰ LAW from SSTs was not included in the request because DOE had not made a decision on the disposition of waste from SSTs at that time.

(58 FR 12342, “States of Washington and Oregon: Denial of Petition for Rulemaking”).⁸¹ On March 4, 1993 the NRC denied that petition, partly on the basis that the principles for waste classification are well established and can be applied on a case-by-case basis without revision to the regulations. On March 2, 1993, NRC issued a letter to DOE (Letter providing *States of Washington and Oregon: Denial of Petition for Rulemaking* to U.S. Department of Energy [Bernero 1993]) referring to its denial of this petition:

“The Commission has recently completed its review of a rulemaking petition from the States of Washington and Oregon on the subject of the double-shell tank wastes⁸² and has indicated ... that it would regard the residual fraction as "incidental" waste, based on the Commission’s understanding that DOE will assure that the waste: (1) has been processed (or will be further processed) to remove key radionuclides to the maximum extent that is technically and economically practical; (2) will be incorporated in a solid physical form at a concentration that does not exceed the applicable concentration limits for Class C low-level waste as set out in 10 CFR Part 61; and (3) will be managed, pursuant to the Atomic Energy Act, so that safety requirements comparable to the performance objectives set out in 10 CFR Part 61 are satisfied.”

NRC agreed that the criteria proposed by DOE to classify these wastes were appropriate [WHC-SD-WM-ES-331, *Identification of Potential Transuranic Waste Tanks at the Hanford Site*, Appendix A - “Letter from R. M. Bernero (U.S. Nuclear Regulatory Commission) to A. J. Rizzo (U.S. Department of Energy) September 25, 1989” (Bernero 1989)]. DOE later incorporated these criteria in relevant part into the criteria in DOE M 435.1-1, *Radioactive Waste Management Manual*, Chapter II.B.(2)(a).

DOE abandoned the grout vault disposal program in January 1994 and agreed to milestones to vitrify both the HLW as well as some of the LAW portion of the tank waste under the *Hanford Federal Facility Agreement and Consent Order* (HFFACO, also known as the Tri-Party Agreement or TPA [Ecology et al., 1989]), that have evolved into HFFACO Milestone M-062-00.

DOE and the Westinghouse Hanford Company then used the three criteria to build a technical case for treating the liquid fraction of the tank waste (supernate and dissolved saltcake) using simple liquid/solid separations and one stage of ion exchange to produce LAW suitable for onsite

⁸¹ The States asked the NRC to: (1) Establish a process to evaluate the treatment of defense reprocessing wastes in tanks so that such wastes will not be considered HLW if, prior to disposal, each tank is treated to remove the largest technically achievable amount of radioactivity; and (2) Require that the heat produced by residual radionuclides, together with the heat of reaction during grout processing (if employed as a treatment technology), will be within limits established to ensure that grout meets temperature requirements for long-term stability for low-level waste forms.

⁸² DOE’s initial plan was to remove supernate waste from only the DSTs, treat it with grout, and dispose of the “residual fraction” in grout vaults that were to be permitted under RCRA. DOE later abandoned the grout vault program and agreed, through the *Hanford Federal Facility Agreement and Consent Order* (Ecology et al. 1989), to vitrify both the HLW and some of the LAW. For clarity, the “residual fraction” referred to here should not be confused with the tank waste residuals that remain in tanks after retrieval operations are completed.

disposal. This technical case was described in the TBR and an interim performance assessment (WHC-EP-0884, *Hanford Low-Level Tank Waste Interim Performance Assessment*) that evaluated disposal of the VLAW onsite inside concrete vaults.⁸³

The abstract for the TBR stated as follows:

“The overall objective of this report is to provide a technical basis to support a U.S. Nuclear Regulatory Commission determination to classify the low-activity waste from the Hanford Site single-shell and double-shell tanks as "incidental" wastes after removal of additional radionuclides and immobilization. The proposed processing method, in addition to the previous radionuclide removal efforts, will remove the largest practical amount of total site radioactivity, attributable to high-level waste, for disposal in a deep geologic repository. The remainder of the waste would be considered "incidental" waste and could be disposed onsite.”

DOE transmitted the TBR to the NRC by Letter 96-TWR-020, “Classification of Hanford Low-Activity Waste Fraction.” Although DOE had previously excluded SST waste from consideration, this letter requested inclusion of the SST waste based on the preferred alternative in DOE/EIS-0189, which would treat and dispose of the SST waste in the same manner as the DST waste. As noted therein, “The baseline is a vitrified waste form although other waste forms would be acceptable if they meet the same performance requirements.” This letter specifically did not request agreement on any residual waste that may remain in the tanks following waste retrieval. DOE also transmitted WHC-EP-0884 to the NRC for review.

In the 1997 Provisional Agreement (NRC 1997) that resulted, the NRC restated the three criteria from its 1989 and 1993 letters and expressed the conditions and limitations of that Provisional Agreement:

(1) “[W]astes have been processed (or will be further processed) to remove key radionuclides to the maximum extent that is technically and economically practical”.

D2.0 U.S. NUCLEAR REGULATORY COMMISSION CONDITIONS

D2.1 U.S. Nuclear Regulatory Commission Condition 1

“It is considered that Criterion One for classifying the Hanford site LAW fraction as incidental waste will be met if the waste management plan presented in the Technical Basis report is followed. Note that if actual radionuclide inventories, either in the tanks or following separation, are significantly higher than or different in character from those projected [8.5 MCi activity based on December 31, 1999 decay date], compliance with this criterion will require re-evaluation by NRC.”

⁸³ Concrete vaults are presently not part of the disposal system for the VLAW.

(2) “[W]astes will be incorporated in a solid physical form at a concentration that does not exceed the applicable concentration limits for Class C [low-level waste] as set out in 10 CFR Part 61.”

D2.2 U.S. Nuclear Regulatory Commission Condition 2

“If the radionuclide inventories in the LAW are significantly higher than those projected in the Technical Basis report, or if the waste form type or total volume are altered, re-evaluation of conformance with this criterion will be necessary.”

(3) “[W]astes are to be managed, pursuant to the Atomic Energy Act, so that safety requirements comparable to the performance objectives set out in 10 CFR Part 61, Subpart C are satisfied.”

D2.3 U.S. Nuclear Regulatory Commission Condition 3

“Although the Interim PA is preliminary, it indicates that the performance objectives of Part 61 will be met. Consistent with the preliminary nature of this Interim PA, the staff’s preliminary finding is that Criterion Three appears to be satisfied. As the disposal facility site is chosen, the disposal facility design is completed, treatment alternatives are selected, the LAW form is determined, and proper characterization of the contents of the tanks is confirmed, the various assumptions and input parameters are likely to be further refined.”

The overall conclusion by the NRC was:

“Based on the preliminary information provided in the DOE Technical Basis report and the Interim PA, the staff’s preliminary finding is a provisional agreement that the LAW portion of the Hanford tank waste planned for removal from the tanks and disposal on-site is incidental waste and is, therefore, not subject to NRC licensing authority. Staff considers that the information presented is not sufficient to make an absolute determination at this time.”

“Successive PAs should be submitted as supplements to the Technical Basis report so that they can be reviewed to confirm the current analysis and resolve any outstanding issues. Other specific changes that would necessitate DOE re-evaluation and further consultation with NRC include, but are not limited to, the following:

- 1) Continuing characterization of tank waste results in a determination that the radionuclide inventory in the HLW tanks is higher than or different from that used to develop the Technical Basis report and the Interim PA. This would affect the resolution of all three criteria.
- 2) The LAW fraction of the Hanford tank waste is not vitrified, or the final volume of the waste form is significantly different from that projected in the Technical Basis report. The waste form is a determining factor in

classification of waste as Class A, B, or C (Criterion Two), and would also impact PA (Criterion Three).

- 3) Final selection of the LAW disposal site, or changes to site characterization parameters will affect the resolution of Criterion Three.”

DOE provided the NRC with an updated PA in 2000 (DOE/ORP-2000-19, *Annual Summary of ILAW Performance Assessment*, Rev. 0) that corrected issues the NRC noted in the interim PA.

D3.0 U.S. NUCLEAR REGULATORY COMMISSION PROVISIONAL AGREEMENT REFERENCE

The following pages provide a copy of the letter with NRC’s provisional agreement (NRC 1997).



UNITED STATES
NUCLEAR REGULATORY COMMISSION
WASHINGTON, D.C. 20555-0001

June 9, 1997

Mr. Jackson Kinzer, Assistant Manager
Office of Tank Waste Remediation System
U.S. Department of Energy
Richland Operations Office
P.O. Box 550
Richland, WA 99352

SUBJECT: CLASSIFICATION OF HANFORD LOW-ACTIVITY TANK WASTE FRACTION

Dear Mr. Kinzer:

The U.S. Nuclear Regulatory Commission has received your letter dated November 7, 1996, requesting NRC agreement that the Hanford tank waste planned for removal from the tanks and disposal on-site is incidental waste [i.e., not high-level waste (HLW)] and, therefore, would not be subject to NRC licensing authority. In response to your request, NRC and contractor staff [Center for Nuclear Waste Regulatory Analyses (CNWRA)] have reviewed the "Technical Basis for Classification of Low-Activity Waste Fraction from Hanford Site Tanks" (Technical Basis report) and supporting documents, including the "Hanford Low-Level Tank Waste Interim Performance Assessment" [Interim Performance Assessment (PA)], to determine whether there is reasonable assurance that the tank waste slated for disposal as low-activity waste (LAW) meets the incidental waste classification criteria specified in the March 2, 1993, letter from R. Bernero, NRC, to J. Lytle, U.S. Department of Energy (DOE).

Criterion One from the March 1993 letter specifies that "...wastes have been processed (or will be further processed) to remove key radionuclides to the maximum extent that is technically and economically practical." To comply with this criterion, available separation technologies were identified for each of the main radionuclides of interest and individually evaluated to determine the status of the technology and the radionuclide removal efficiency. Three separation technologies were deemed both technically and economically practical. Currently, it is expected that all three will be used. The three technologies include a simple solids-liquids separation, removal of transuranics wastes from selected tanks, and single-cycle ion exchange removal of cesium-137 from certain wastes. Approximately 3.1×10^{17} Bq (8.5 MCi) of activity will remain in the LAW, which corresponds to about 2 percent of the estimated 15.6×10^{18} Bq (422 MCi) generated at the Hanford site (based on a December 31, 1999, decay date).

NRC staff concludes that available separation processes have been extensively examined to determine those that are both technically and economically practical, and that the residual 2 percent of the activity generated at the Hanford site represents the maximum amount of separation currently technically and economically practical for this case. It is considered that Criterion One for classifying the Hanford site LAW fraction as incidental waste will be met if the waste management plan presented in the Technical Basis report is followed. Note that if actual radionuclide inventories, either in the tanks or following separation, are significantly higher than or different in character from those projected, compliance with this criterion will require re-evaluation by NRC.

RECEIVED
JUN 16 1997
197-TWR-371
- - RL / RM

Compliance with Criterion Two, "...wastes will be incorporated in a solid physical form at a concentration that does not exceed the applicable concentration limits for Class C [low-level waste] as set out in 10 CFR Part 61." was determined using the estimated total vitrified waste volume (158,000 m³)(42,000,000 gallons) in conjunction with projected radionuclide activities. From these calculations, which NRC staff verified, the vitrified waste form is expected to meet the limits for Class C or less, as specified. Note that molten metal processing is also being considered for the LAW form. This method would considerably decrease the total waste form volume such that the waste classification could be affected. If the radionuclide inventories in the LAW are significantly higher than those projected in the Technical Basis report, or if the waste form type or total volume are altered, re-evaluation of conformance with this criterion will be necessary.

To evaluate Criterion Three, "...wastes are to be managed, pursuant to the Atomic Energy Act, so that safety requirements comparable to the performance objectives set out in 10 CFR Part 61, Subpart C are satisfied," an Interim PA was prepared. The DOE PA was performed to the requirements of DOE Order 5820.2A, "Radioactive Waste Management," September 26, 1988. This order is similar to the 10 CFR Part 61 performance objectives.

The Interim PA is the first of three PAs planned and is somewhat preliminary; it was conducted before selection of a disposal facility site and design, specific treatment alternatives, LAW form, or a complete and verified radiological and chemical characterization of the contents of the Hanford tanks. Our review identified a number of specific issues and concerns associated with the Interim PA, documented in the February 6, 1997, Request for Additional Information (RAI) from M. Bell, NRC, to D. Wodrich, DOE, and discussed in the enclosed CNWRA report. DOE's responses to the RAI constitute Appendix B to the CNWRA report. Many of the RAI comments cannot be fully resolved until the site, facility design, and solidification process are selected. It is expected that uncertainties and concerns identified with respect to the Interim PA can be satisfactorily addressed in the subsequent PAs.

Although the Interim PA is preliminary, it indicates that the performance objectives of Part 61 will be met. Consistent with the preliminary nature of this Interim PA, the staff's preliminary finding is that Criterion Three appears to be satisfied. As the disposal facility site is chosen, the disposal facility design is completed, treatment alternatives are selected, the LAW form is determined, and proper characterization of the contents of the tanks is confirmed, the various assumptions and input parameters are likely to be further refined. Please submit future PAs as supplements to the Technical Basis report so that they can be reviewed to confirm the current analysis and resolve any outstanding issues.

Based on the preliminary information provided in the DOE Technical Basis report and the Interim PA, the staff's preliminary finding is a provisional agreement that the LAW portion of the Hanford tank waste planned for removal from the tanks and disposal on-site is incidental waste and is, therefore, not subject to NRC licensing authority. Staff considers that the information presented is not sufficient to make an absolute determination at this time. Note that if the Hanford tank waste is not managed using a program comparable

to that set forth in the Technical Basis report, or the current characterization of tank contents is not confirmed, the incidental waste classification must be revisited by DOE, and the NRC consulted. As a fundamental element of the incidental waste classification, DOE must ensure the contractors that perform LAW separation and disposal do so in accordance with the criteria set forth in the March 1993 letter and the approved Technical Basis report.

Successive PAs should be submitted as supplements to the Technical Basis report so that they can be reviewed to confirm the current analysis and resolve any outstanding issues. Other specific changes that would necessitate DOE re-evaluation and further consultation with NRC include, but are not limited to, the following:

- 1) Continuing characterization of tank waste results in a determination that the radionuclide inventory in the HLW tanks is higher than or different from that used to develop the Technical Basis report and the Interim PA. This would affect the resolution of all three criteria.
- 2) The LAW fraction of the Hanford tank waste is not vitrified, or the final volume of the waste form is significantly different from that projected in the Technical Basis report. The waste form is a determining factor in classification of waste as Class A, B, or C (Criterion Two), and would also impact PA (Criterion Three).
- 3) Final selection of the LAW disposal site, or changes to site characterization parameters will affect the resolution of Criterion Three.

If you have any questions about the details of this letter, please contact Michael Bell of my staff at (301) 415-7286.

Sincerely,



Carl J. Paperiello, Director
Office of Nuclear Material
Safety and Safeguards

Enclosure: As stated

cc: D. Wodrich, DOE ✓
D. Pepson, DOE
D. Bartus, EPA
R. Stanley, WA State
S. Dahl, WA State
B. Nichols, WA State
J. Erickson, WA State
M. Blazek, OR State
D. Stewart-Smith, OR State
R. Paris, OR State
R. Sockzehigh, YTC
R. Jim, YIN

D4.0 REFERENCES

- 10 CFR Part 50, “Domestic Licensing of Production and Utilization Facilities,” *Code of Federal Regulations*, as amended.
- 10 CFR Part 61, “Licensing Requirements for Land Disposal of Radioactive Waste,” Subpart D—Technical Requirements for Land Disposal Facilities, §61.55, “Waste classification,” *Code of Federal Regulations*, as amended.
- 58 FR 12342, 1993, “States of Washington and Oregon: Denial of Petition for Rulemaking,” *Federal Register*, Vol. 58, pp. 12342–12347 (March 4).
- 62 FR 8693, 1997, “Record of Decision for the Tank Waste Remediation System, Hanford Site, Richland, WA,” *Federal Register*, Vol. 38, pp. 8693–8704 (February 26).
- 96-TWR-020, 1996, “Classification of Hanford Low-Activity Waste Fraction” (letter from J. Kinzer [Office of Tank Waste Remediation System] to C. Paperiello [Office of Nuclear Materials Safety and Safeguards, U.S. Nuclear Regulatory Commission], November 7), U.S. Department of Energy, Richland Operations Office, Richland, Washington.
- Bernero, 1989, Appendix A – “Letter from R. M. Bernero (U.S. Nuclear Regulatory Commission) to A. J. Rizzo (U.S. Department of Energy) September 25, 1989” of WHC-SD-WM-ES-331, 1995, *Identification of Potential Transuranic Waste Tanks at the Hanford Site*, Rev. 0, Westinghouse Hanford Company, Richland, Washington.
- Bernero, R. M., 1993, letter from providing States of Washington and Oregon: Denial of Petition for Rulemaking to J. Lytle, Deputy Assistant Secretary for Waste Operations, Office of Environmental Restoration and Waste Management, U.S. Department of Energy, Washington, D.C., March 2, Office of Nuclear Materials Safety and Safeguards, U.S. Nuclear Regulatory Commission, Washington, D.C.
- DOE/EIS-0113, 1987, *Final Environmental Impact Statement, Disposal of Hanford Defense High-Level, Transuranic and Tank Wastes, Hanford Site, Richland, Washington*, U.S. Department of Energy, Washington, D.C.
- DOE/EIS-0189, 1996, *Tank Waste Remediation System, Hanford Site, Richland, Washington, Final Environmental Impact Statement*, U.S. Department of Energy, Washington, D.C., and Washington State Department of Ecology, Olympia, Washington.
- DOE M 435.1-1, 2011, *Radioactive Waste Management Manual*, Change 2, U.S. Department of Energy, Washington, D.C.
- DOE/ORP-2000-19, 2000, *Annual Summary of ILAW Performance Assessment*, Rev. 0, U.S. Department of Energy, Office of River Protection, Richland, Washington.

- Ecology et al, 1989, *Hanford Federal Facility Agreement and Consent Order – Tri-Party Agreement*, 2 vols., as amended, State of Washington Department of Ecology, U.S. Environmental Protection Agency, and U.S. Department of Energy, Olympia, Washington.
- NRC, 1997, “Classification of Hanford Low-Activity Waste Fraction” (letter from C. J. Paperiello, Office of Nuclear Material Safety and Safeguards to J. Kinzer, U.S. Department of Energy, Richland Operations Office, June 9), U.S. Nuclear Regulatory Commission, Washington, D.C.
- Rizzo, A. J., 1989, letter to R. M. Bernero, Director, Office of Nuclear Materials Safety and Safeguards, U.S. Nuclear Regulatory Commission, Washington, D.C., in WHC-SD-WM-TI-699, *Technical Basis for Classification of Low-Activity Waste Fraction from Hanford Site Tanks*, Rev. 2, Appendix A - Correspondence, pp. A-9 – A-20, Westinghouse Hanford Company, Richland, Washington.
- WHC-EP-0884, 1996, *Hanford Low-Level Tank Waste Interim Performance Assessment*, Rev. 0, Westinghouse Hanford Company, Richland, Washington.
- WHC-SD-WM-TI-699, 1996, *Technical Basis for Classification of Low-Activity Waste Fraction from Hanford Site Tanks*, Rev. 2, Westinghouse Hanford Company, Richland, Washington.

This page is intentionally left blank.

APPENDIX E

REPURPOSING OF DOUBLE-SHELL TANK 241-AP-106 AS LOW-ACTIVITY WASTE FEED TANK

Appendix Purpose

The purpose of this appendix is to describe the process for repurposing the DST AP-106 into a feed tank for feeding LAW to the WTP.

Appendix Content

This appendix describes the specific steps for converting AP-106 into a LLW feed tank.

Key Points

- The multiple retrievals and flushing of AP-106 enable its use as a feed tank for LAW.

TABLE OF CONTENTS

| | | |
|-------------|--------------------|-----|
| E1.0 | GENERAL PLAN | E-1 |
| E2.0 | STEP PROCESS..... | E-1 |
| E3.0 | REFERENCES | E-3 |

ABBREVIATIONS AND ACRONYMS

| | |
|-------|---|
| DFLAW | Direct-Feed Low-Activity Waste |
| DST | double-shell tank |
| HD | high density |
| LAW | low-activity waste or Low-Activity Waste Vitrification Facility |
| TSCR | tank-side cesium removal |
| WTP | Hanford Tank Waste Treatment and Immobilization Plant |

E1.0 GENERAL PLAN

The double-shell tank (DST) 241-AP-106 (AP-106) repurposing process is the sequence of tank additions and transfers that will remove the ^{137}Cs inventory from AP-106 (RPP-PLAN-62353, *Tank 241-AP-106-Cs-137 Removal for Repurposing Process Control Plan*). It is not possible to remove enough of the ^{137}Cs inventory with a single transfer because of the supernate heel that will remain in the tank between the tank bottom and transfer pump inlet. The repurposing process steps are designed to remove ^{137}Cs more effectively and efficiently as compared to regular supernate transfers. The process steps started in late 2019.

Tank AP-106 currently stores supernate. The tank is being repurposed to serve as the lag storage tank holding low-activity waste (LAW) feed for the LAW Vitrification Facility at the Hanford Tank Waste Treatment and Immobilization Plant (WTP), under the Direct-Feed Low-Activity Waste (DFLAW) approach. Supernate currently stored in tank 241-AP-107 will be treated at the Tank Side Cesium Removal (TSCR) unit to remove suspended particles and ^{137}Cs before being transferred temporarily to tank AP-106. When the LAW Vitrification Facility at the WTP becomes operational, that supernate (i.e., the LAW feed) will be transferred to the LAW Vitrification Facility for vitrification. If the supernate remaining in tank AP-106 after repurposing contains too much ^{137}Cs , then the TSCR treated feed may not meet the LAW feed requirements and could not be sent to the LAW Vitrification Facility.

E2.0 STEP PROCESS

The repurposing process is basically six steps.

- Step 1:** Decant tank AP-106 to tank 241-AP-102.
- Step 2:** Add a water cap to tank AP-106 and decant to tank 241-AP-102.
- Step 3:** Adjust tank AP-106 supernate chemistry, recirculate, and sample. Decant to tank 241-AP-108.
- Step 4:** Dilute AP-106 supernate with water and recirculate. Decant to tank 241-AN-101.
- Step 5:** Inject caustic under and add a water cap over the tank AP-106 supernate. Decant to tank 241-AP-102.
- Step 6:** Dilute tank AP-106 supernate, recirculate, and then sample. If needed, adjust tank 241-AP-106 supernate chemistry and recirculate.

The details of the steps repurposing tank AP-106 include the following activities.

1. Add 75 kgal (27.3 inches) of raw water to dilute the remaining supernate to a density of 1.11 g/mL. The raw water will be added to the tank bottom via a new drop leg that is extended close to the tank floor. Tank recirculation is needed to ensure the diluted supernate is well mixed. After this step, the new tank level will be approximately 51.3 inches.
2. Decant the diluted supernate back down to about 14 inches or until loss of suction/cavitation. Tank 241-AP-102 is currently planned to receive this diluted supernate volume.

3. Add one truck of high density (HD) solution consisting of 10M NaOH/2.5M NaNO₂ and two trucks of 8M NaNO₂ to maintain control of chemistry in future process steps. The total chemical additions for this step will be three trucks or 12 kgal (4.4 inches).
4. Add 90 kgal (32.6 inches) of raw water through the pump column or drop leg to enhance mixing and recirculate through the 2-inch slurry line for 40 to 80 hours. Expected recirculation time is 72 hours to ensure the remaining diluted supernate is well mixed. A well-mixed tank is important for cesium removal and tank chemistry. After this step, the new tank level will be approximately 51 inches.
5. Collect a sample to evaluate.
6. Decant the mixed diluted supernate back down to 14 inches or until loss of suction/cavitation. Tank 241-AP-108 is currently planned to receive this diluted supernate volume.
7. Add 102 kgal (37 inches) of raw water through the pump column or drop leg to enhance mixing and recirculate through the 2-inch slurry line for 40 to 80 hours. Tank recirculation is necessary to maintain chemistry control compliance.
8. Decant the diluted supernate to 18 inches. Tank 241-AN-101 is currently planned to receive this diluted supernate volume.
9. Inject 40 kgal (14.5 inches) of HD solution to the tank bottom via the extended drop leg to lift the diluted supernate off the tank bottom, raising it to a level above the transfer pump inlet where it can be removed. Observations from RPP-RPT-60162, *Hanford Double-Shell Tank Supernatant Mixing: Activities, Observations, and Modeling*, suggest that waste sources that have density differences greater than 0.2 g/mL typically do not mix and form separate layers. The density of HD solution is 1.41 g/mL (OLI Flowsheet model output), which is 0.3 g/mL greater than the density of diluted supernate (1.11g/mL). The new tank level will be 32.5 inches.
10. Add 75 kgal (27.3 inches) of raw water on top of the supernate through the new drop leg. It is assumed that HD solution injected in the previous step will result in separate layers with 14.5 inches of HD solution on the bottom and 15 inches of diluted supernate on the top prior to the addition of 27.3 inches of raw water. After this step, the new tank level will be approximately 60 inches.
11. Decant the tank level down to 18 inches. The transfer pump intake is about 12.7 inches from the tank floor, which locates it in the HD solution layer. When the subsequent transfer is initiated, the top section of HD solution layer will be first drawn into the pump intake and gradually followed by diluted supernate. Tank AP-241-102 is currently planned to receive this dilute supernate volume. At the end of this process step, the remaining waste profile in tank AP-106 should consist of a 12.7-inch HD solution layer with 5.3 inches residual diluted supernate laying on top.

12. Add at least 116 kgal (42.2 inches) of raw water and recirculate. Tank recirculation is necessary for chemistry control. The tank level will increase to approximately 60 inches at the completion of this step.
13. Collect a sample of the mixed waste to verify that the target ^{137}Cs (less than 1.20×10^{-2} mole or 142 Ci) is met. Given the estimated residual volume is 165 kgal, the equivalent target ^{137}Cs concentration is 2.28×10^{-4} Ci/L. This target ^{137}Cs concentration will change if the residual volume is different from that estimated in the flowsheet.

Two of the repurposing process steps involve the creation of layers within the tank. One of those steps will create a water layer, termed a “water cap,” on top of the supernate. Another of those steps will create both a caustic layer under the supernate and a water cap on top of the supernate. These layers will make ^{137}Cs removal during subsequent transfers more efficient than would otherwise be possible. A new drop leg (Section 2.2.4), installed into tank AP-106 Riser 12, will enable the creation of the water and caustic layers. That drop leg has two nozzles: one approximately 3 inches from the tank bottom for caustic additions and another approximately 54 inches from the tank bottom for water additions. Both nozzles were designed to minimize mixing with the existing supernate.

E3.0 REFERENCES

- RPP-PLAN-62353, 2019, *Tank 241-AP-106-Cs-137 Removal for Repurposing Process Control Plan*, Rev. 3, Washington River Protection Solutions, LLC, Richland, Washington.
- RPP-RPT-60162, 2017, *Hanford Double-Shell Tank Supernatant Mixing: Activities, Observations, and Modeling*, Rev. 0, Washington River Protection Solutions, LLC, Richland, Washington.

This page is intentionally left blank.

APPENDIX F

COMPARISON OF LOW-ACTIVITY WASTE PRETREATMENT SYSTEM PRIOR APPROACH AND DIRECT-FEED LOW-ACTIVITY WASTE APPROACH TO FILTRATION

Appendix Purpose

The purpose of this appendix is to describe the difference between the historical and planned filtration processes associated with LAW feed.

Appendix Content

This appendix describes the specific differences between cross-flow filtration (prior planned methodology), and dead-end filtration (current pretreatment design).

TABLE OF CONTENTS

| | | |
|-------------|-------------------------------------|-----|
| F1.0 | PROCESS FILTRATION DISCUSSION | F-1 |
| F2.0 | REFERENCES | F-2 |

FIGURES

| | | |
|-------------|--|-----|
| Figure F-1. | Cross-Flow vs. Dead-End Filtration. | F-1 |
|-------------|--|-----|

ABBREVIATIONS AND ACRONYMS

| | |
|-------|--|
| DFLAW | Direct-Feed Low-Activity Waste |
| LAWPS | Low-Activity Waste Pretreatment System |

F1.0 PROCESS FILTRATION DISCUSSION

In the Direct-Feed Low-Activity Waste (DFLAW) configuration, feed is filtered using a backwashable dead-end filter to remove undissolved solids (see Section 4.2.2.1) eliminating the cross-flow filtration system that was part of the prior Low-Activity Waste Pretreatment System (LAWPS) design. A simplified comparison of these two filtration methods is shown in Figure F-1.

Figure F-1. Cross-Flow vs. Dead-End Filtration.

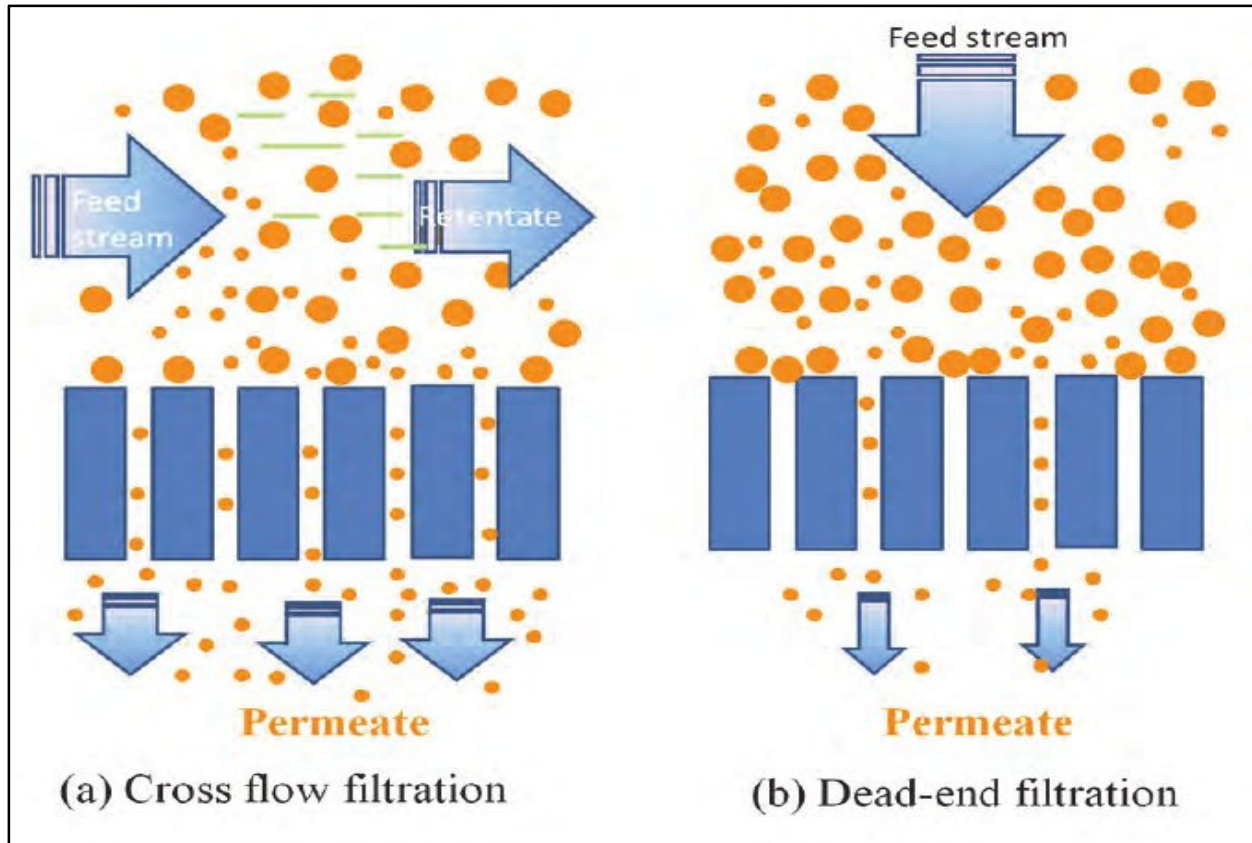

Source: “Organic–Inorganic Mesoporous Silica Nanotube Hybrid Anodic Alumina Membranes for Ultrafine Filtration of Noble Metal Nanoparticles” (El-Safty and Hoa 2012).

The benefits associated with the elimination of cross-flow filtration for removal of solids include the following.

- Reduces facility safety concerns associated with high-pressure filtration system and equipment such as spray leak releases. Consequently, a reduction in key accident scenarios enables a reduction in the facility seismic design criteria.
- Based on external expert review [RPP-RPT-60405, *External Expert Review of the Low-Activity Waste Pretreatment System (LAWPS) Project*], dead-end filtration will be able to maintain the controls required by the DFLAW criticality safety evaluation report for preventing criticality from plutonium.

- Eliminates nonessential scope and reduces conservatism in the safety basis, leading to delivery of feed to the Low-Activity Waste Vitrification Facility that meets the Amended Consent Decree milestones and the U.S. Department of Energy’s cost target.

F2.0 REFERENCES

El-Safty, S A. and N. D. Hoa, 2012, “Organic–Inorganic Mesoporous Silica Nanotube Hybrid Anodic Alumina Membranes for Ultrafine Filtration of Noble Metal Nanoparticles,” Chapter 7 in Noble Metals, Y. Su (Ed.), IntechOpen Limited, London, United Kingdom.

RPP-RPT-60405, 2017, *External Expert Review of the Low-Activity Waste Pretreatment System (LAWPS) Project*, Rev. 0, Washington River Protection Solutions, LLC, Richland, Washington.